

# SEARS

## OWNER'S MANUAL

MODEL NO.  
390.304692

**CAUTION:**  
Read and Follow  
All Safety Rules and  
Operating Instructions  
Before First Use of  
This Product.

Save This Manual For  
Future Reference.



## CRAFTSMAN<sup>®</sup> SUBMERSIBLE SUMP PUMP

- Safety Instructions
- Installation
- Electrical
- Maintenance
- Repair Parts

Sears, Roebuck and Co., Hoffman Estates, IL 60179 U.S.A.

## CONTENTS

INTRODUCTION/WARRANTY .....	2
SAFETY .....	2-3
INSTALLATION.....	3-4
ELECTRICAL.....	4
MAINTENANCE.....	5
SERVICE.....	5
PARTS.....	6

## INTRODUCTION

Please read our instructions before you install and use your new pump; this will help you obtain full value and good service from it. It will also help you avoid needless service costs that result from causes we cannot control and cannot cover in our warranty.

### TWO YEAR LIMITED WARRANTY

Provided that it is installed and operated according to the owner's manual instructions, if this pump fails due to a defect in material or workmanship within one year from the date of purchase, it will be repaired or replaced free of charge.

During the second year from the purchase date, a free pump part will be supplied for a defective one. You must pay the labor cost if you wish to have it installed.

Warranty service is available by returning this product to place of purchase for replacement, or by calling 1-800-4-MY-HOME® to arrange for part replacement or product repair.

This warranty is VOID if this pump is used for commercial or rental purposes.

Sears is not liable for loss or damage to property, nor for any incidental or consequential loss or expense from property damage, that results directly or indirectly from the use of this product.

This warranty gives you specific legal rights, and you may also have other rights which vary from state to state.

Sears Roebuck and Co., Dept. 817WA, Hoffman Estates, IL 60179

## GENERAL SAFETY INFORMATION

Carefully read and follow all safety instructions in this manual or on pump.

**⚠** This is the safety alert symbol. When you see this symbol on your pump or in this manual, look for one of the following signal words and be alert to the potential for personal injury!

**⚠ DANGER** warns about hazards that **will** cause serious personal injury, death or major property damage if ignored.

**⚠ WARNING** warns about hazards that **will** or **can** cause serious personal injury, death or major property damage if ignored.

**⚠ CAUTION** warns about hazards that **will** or **can** cause minor personal injury or property damage if ignored.

The word **NOTICE** indicates special instructions which are important but not related to hazards.

Electrically powered sump pumps normally give many years of trouble-free service when correctly installed, maintained, and used. However, unusual circumstances (interruption of power to the pump, dirt/debris in the sump, flooding that exceeds the pump's capacity, electrical or mechanical failure in the pump, etc.) may prevent your pump from functioning normally. To prevent possible water damage due to flooding,

consult your local Sears store about installing a secondary sump pump or a DC backup sump pump. See "Service", Page 6, for information about common sump pump problems and remedies.

1. To avoid risk of serious bodily injury and property damage, read safety instructions carefully before installing pump.
2. Follow local and/or national plumbing and electrical codes when installing pump.

3. **⚠ WARNING** To avoid fatal shocks, proceed as follows if pump needs servicing:

- A. **Disconnect power to pump outlet box before pulling pump cord plug.** After plug is pulled, let pump cool for 20 minutes before attempting to work on it. Modern motors may operate at high temperatures.
- B. **Take extreme care when changing fuses.** To reduce the chance of fatal electrical shocks, **DO NOT** stand in water or put your finger in the fuse socket.
- C. **Ground** the electrical outlet box.
- D. **Use only an individual branch circuit with a grounded outlet for cord plug.**

# SAFETY / INSTALLATION

4. **Never run pump dry.** To do so can damage internal parts, overheat the pump (which can cause burns to people handling or servicing the pump), and **will void the warranty!**
5. **DO NOT** attempt to oil the pump motor. A special oil has been put into the motor housing at the factory; use of any other oil will void the warranty and could damage the pump.
6. This pump is recommended for use in permanent installations only. This pump has not been investigated for use in swimming pool areas.
7. Know the pump application, limitations, and potential hazards. Not for use with salt water or brine.

**▲ WARNING** Do not use in explosive atmospheres. Pump water only with this pump. Failure to follow this warning can result in personal injury and/or property damage.

8. Release all pressure within the system before servicing any component.
9. Drain water from the system before servicing.
10. Secure the discharge line before starting the pump. An unsecured discharge line will whip, possible causing personal injury and/or property damage.
11. Periodically inspect pump and system components. Perform routine maintenance as required (See MAINTENANCE).
12. Provide a means of pressure relief for pumps whose discharge line can be shut-off or obstructed.
13. Personal Safety:
  - a. Wear safety glasses at all times when working with pumps.
  - b. Keep work area clean, uncluttered and properly lighted - replace all unused tools and equipment.
  - c. Keep visitors at a safe distance from the work area.
  - d. Make workshop child-proof - with padlocks, master switches, and by removing starter keys.
14. This equipment is only for use on 115 volt (single phase) and is equipped with an approved 3-conductor cord and 3-prong, grounding-type plug.

**▲ WARNING** To reduce the risk of electric shock, pull plug before servicing. This pump has not been investigated for use in swimming pool areas. This pump is supplied with a grounding conductor and grounding-type attachment plug. Be certain that it is connected only to a properly grounded grounding-type receptacle.

Where a 2-prong wall receptacle is encountered, it must be replaced with a properly grounded 3-prong receptacle installed in accordance with the National Electrical Code and local codes and ordinances.

15. Protect electrical cord from sharp objects, hot surfaces, oil, and chemicals. Avoid kinking the cord. Replace or repair damaged or worn cords immediately.
16. Do not handle a pump or pump motor with wet hands or when standing on a wet or damp surface, or in water.

**▲ WARNING** Risk of electric shock. If your basement has water or moisture on the floor, do not walk on wet area until all power has been turned off. If shut-off box is in basement, call the electric company to shut-off service to the house, or call your local fire department for instructions. Remove pump and repair or replace. Failure to follow this warning can result in fatal electrical shock.

## ADDITIONAL INSTALLATION MATERIALS (Purchase Separately)

Sump Pump Hose Kit, SEARS Stock No. 27909, containing 24' (7.3M) of 1-1/4" flexible plastic pipe, 1-1/4" plastic adapter and stainless steel clamp. We recommend a Check Valve, SEARS Stock No. 2789 or 2792.

## THE SUMP

Locate sump at lowest place in basement or drained area. Floor drains or drain tiles can also be tiled into sump. Minimum sump size is 10" (254mm) in diameter by 20" deep (508mm). Periodically inspect pump, system components, and sump for debris and foreign objects. Keep sump free from all refuse. Perform routine maintenance as required. Use a sump cover to exclude refuse from sump. Consult local code for cover specifications.

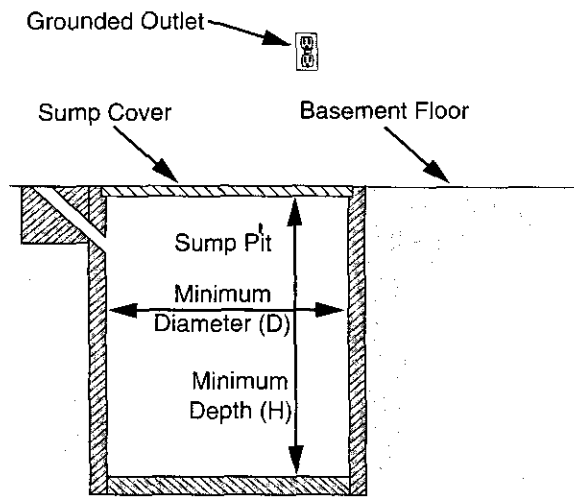

Figure 1

Pump Model	Minimum Diameter (D)	Minimum Depth (H)
390.304692	10" (254mm)	20" (508mm)

## PUMP INSTALLATION

Set the pump on the bottom of the sump, making sure that it sits solidly and is level. Be sure there is enough space around the pump to allow the switch free movement as the sump water level changes. Do not install the pump on clay, earth, or sand surface.

# INSTALLATION / ELECTRICAL

**CAUTION** Risk of flooding. If a flexible discharge hose is used, pump may move around in sump when motor starts. If it moves far enough so that the switch hits the side of the sump, the switch may stick and prevent pump from starting. Make sure that pump is secured so that it cannot walk around in sump.

Hose Kit No. 27909 can be used as the discharge pipe. Run the discharge pipe to the nearest sewer outlet or other point of disposal. Use the most direct route and the fewest turns and elbows possible.

Use Teflon tape to seal threads in plastic pipe. Hand tighten only.

**NOTE:** To avoid backflow into sump when pump shuts off, install a Check Valve, SEARS Stock No. 2789, in threaded discharge port of pump. A SEARS No. 2789 Check Valve is constructed with an anti-airlock hole. If you use a SEARS No. 2792 or any other check valve, drill a 1/8" hole in the discharge pipe just above the pump discharge port and below the Check Valve to prevent pump from airlocking.

Make sure the air-bleed hole is down inside the sump so that it does not run water on the basement floor when the pump is running.

### DO NOT ALLOW PUMP TO RUN DRY!

Be sure to leave at least 5" (127mm) of water above pump base plate when pump stops. Running pump dry could ruin the pump and will void the warranty.

## ELECTRICAL CONNECTIONS

The Sump Pump has a 3-prong electric plug. The third prong is used to ground the pump to prevent possible fatal shock. The third prong should never be removed. Your electrical outlet should be the 3-prong, polarized type with an internal ground.

An individual branch 15 amp electrical circuit is recommended. **DO NOT USE AN EXTENSION CORD.**

### Testing for Ground

For your safety, check your outlet for ground using an Underwriters Laboratory Listed Circuit Analyzer (Figure 2). A Circuit Analyzer will tell you by a pattern of lights if the power, neutral, and ground wires are correctly connected to your outlet. It can also be used to check other outlets in your home. A Circuit Analyzer is available in the Sears Electrical Department.

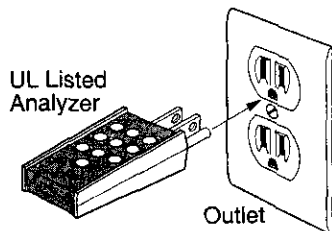

Figure 2

### Grounding Outlet

If your outlet is not grounded, install a copper wire, at least 14 gauge (2mm<sup>2</sup>), from the outlet box, as shown in Figure 3, to a metal cold water pipe. Use ground clamp on pipe.

**IMPORTANT:** The cold water pipe you use as a ground must have metal continuity to electrical ground. If continuity is interrupted by plastic, rubber, or other electrical insulators; such as hoses, fittings, washers or gaskets (including water meter or pump), a metal bypass must be used. Any electrically insulated connector should be jumped (as shown in Figure 4), with a length of No. 4 wire clamped securely at both ends.

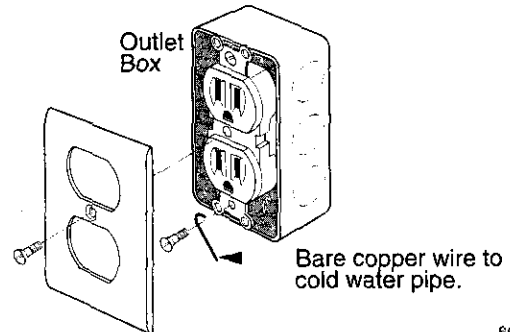

Figure 3

669 0194

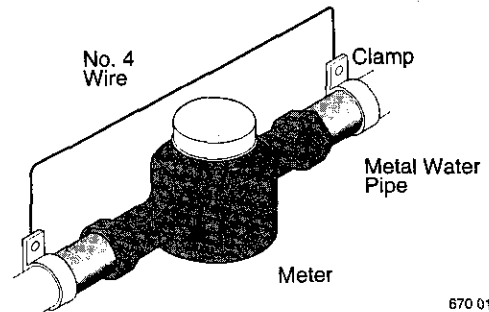

Figure 4

670 0194

### Automatic Thermal Overload Protection

This pump motor has a built-in automatic thermal overload protector. If the motor overheats, the protector will open and cut off power to the motor before the heat damages it internally. The overload will reset automatically and the pump will restart after the pump cools down below the danger point.

**WARNING** DO NOT attempt to work on the pump or motor if the overload seems to have tripped. The motor may restart without warning at any time. You could be injured and the pump damaged if it starts when you are working on it.

DO NOT attempt to repair a non-operational sump pump. Take it to Sears for service by a qualified technician.

### Generator Sizing

Below is the minimum Engine-Generator Watt rating required to power this pump motor. Any additional loads, such as lights, must be added to the listed load and the generator sized accordingly. Generators are available at all Sears Stores.

Pump Model	HP	Minimum Watt Rating of Generator
390.304692	1/3	4500

# MAINTENANCE / SERVICE

## MAINTENANCE

**CAUTION** Make certain that the pump is unplugged before attempting to service or remove any component.

1. The motor in the unit is sealed in oil. No additional lubrication is necessary.
2. **IMPORTANT:** Disassembly of the motor assembly will void the warranty. It might also cause internal leakage and damage to the unit. If repairs are required, return the pump to the dealer from whom it was purchased.
3. Inlet screen should be kept clean and free of all foreign objects.

### Pump Cleaning

**NOTICE:** Attempting to disassemble motor will void the warranty.

1. Disconnect power cord from electrical outlet before working on pump. The volute bottom may be removed to replace impeller or clean pump of mud or debris.
2. Remove screws from volute bottom and clean impeller. Replace the gasket/O-Ring if it is damaged.

### To Reassemble:

Attach volute bottom to volute top with screws.

### General

**WARNING** Risk of electric shock. When servicing pump always disconnect power to electrical outlet and remove pump electric cord from outlet.

1. If pump does not operate:
  - a. Check for loose plug at electric outlet.
  - b. Check for blown fuses or tripped circuit breakers at fuse box/circuit breaker box.
  - c. Be sure nothing interferes with action of automatic float switch.
  - d. If a, b, and c above check OK, plug in a light that you know works. If it lights, take your pump to Sears for service. If it doesn't light, the electrical circuit is faulty; consult a licensed electrician.
2. Pump starts, but blows fuses/trips circuit breakers:
 

After disconnecting power to pump, remove the screen and shield from the bottom of the pump and make sure that the impeller turns freely. Remove any debris obstructing impeller. If pump still does not operate correctly, return it to your nearest Sears Service Department for repairs.
3. Pump runs, but does not empty sump:
  - a. Clean pump intake screen.
  - b. Water may be entering sump faster than the pump can discharge it.

- c. Be sure vertical distance from pump discharge outlet to discharge pipe outlet does not exceed maximum vertical pumping distance shown in "Specifications," below.
- d. Be sure discharge pipe is not plugged or frozen.

## VERTICAL SWITCH REPLACEMENT

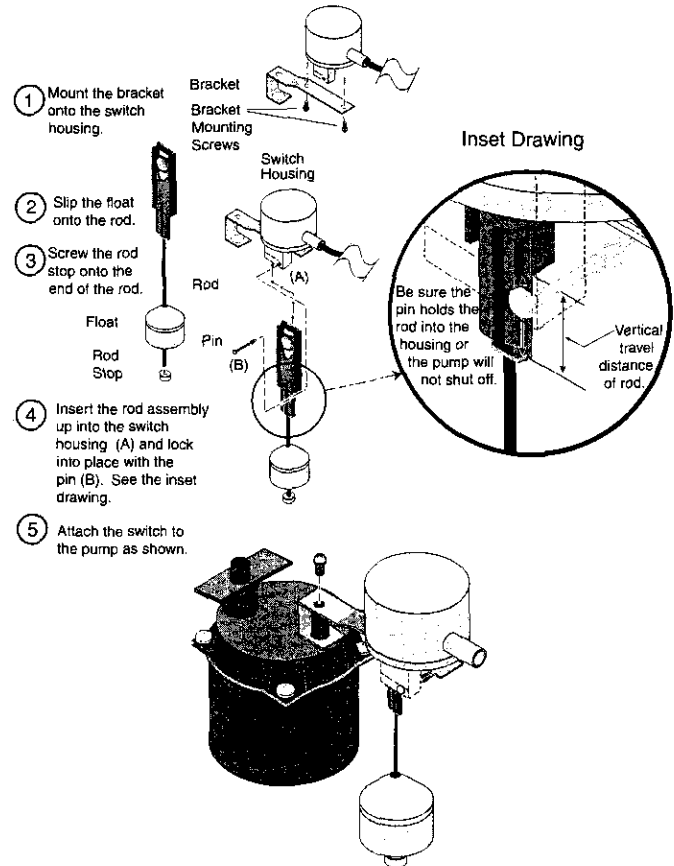

**CAUTION** Make sure pin holds float rod in switch housing; otherwise pump will not shut off.

To check switch operation, run pump through one complete cycle after installation.

**WARNING** Risk of electrical shock. Can burn or kill. Plug pump and switch into a grounded electrical outlet only.

## SPECIFICATIONS

Stock Number	HP	Maximum Amps	Dimensions in inches (mm)			GPM (L/min.) at Vertical Pumping Distance in Feet (M)				
			Length	Width	Height	5' (1.6)	10' (3)	15' (4.6)	20' (6.1)	25' (7.6)
30469	1/3	13.0	9" (229)	6-1/2" (165)	11-1/2" (292)	50 (189)	41 (155)	28 (106)	3 (11.4)	-

# REPAIR PARTS

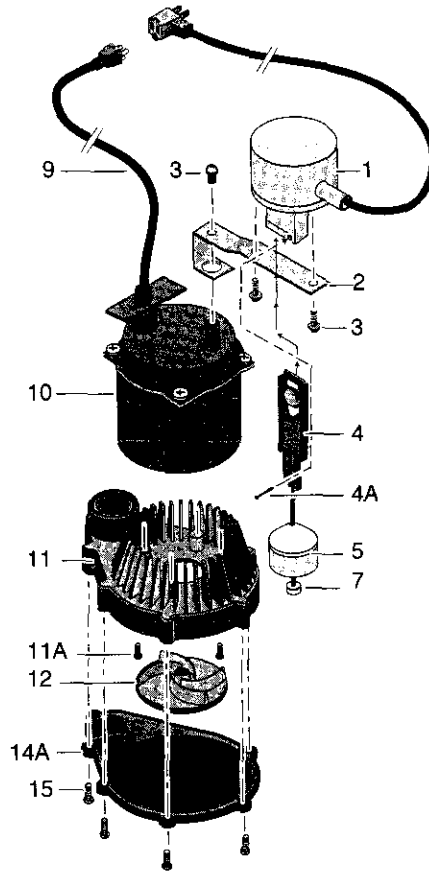

## REPAIR PARTS LIST

Key No.	Part Description	390.304692
1	Switch	PS17-66
2	Mounting Bracket	PS19-18SS
3	Screw	U30-955PS (3 Req.)
4	Float Rod	PS28-17
4A	Float Retainer Pin	PS30-3
5	Float	PS28-18
7	Float Stop	RP0005248
9	Power Cord	PS117-53-TSU
10	Motor Housing	**
11	Upper Volute	PS1-29P
11A	Screws	U30-912PS (4 Req.)
12	Impeller	RP0000911A
14A	Base Plate	PS4-17P
15	Cap Screws	U30-934ZP (8 Req.)

Quantity ONE unless otherwise noted ( ).

• Not illustrated.

\*\* If motor fails, replace entire pump.

To Order Parts in the U.S.A. Call  
**Sears Product Service, 1-800-366-7278**

To Order Parts outside the U.S.A. Call  
**Your local Sears Service Center or Store**



# Get it fixed, at your home or ours!

## Your Home

For repair – in your home – of all major brand appliances, lawn and garden equipment, or heating and cooling systems, **no matter who made it, no matter who sold it!**

For the replacement parts, accessories and owner's manuals that you need to do-it-yourself.

For Sears professional installation of home appliances and items like garage door openers and water heaters.

**1-800-4-MY-HOME®** (1-800-469-4663)

Call anytime, day or night (U.S.A. and Canada)

[www.sears.com](http://www.sears.com)    [www.sears.ca](http://www.sears.ca)

---

## Our Home

For repair of carry-in items like vacuums, lawn equipment, and electronics, call or go on-line for the location of your nearest **Sears Parts & Repair Center.**

**1-800-488-1222**

Call anytime, day or night (U.S.A. only)

[www.sears.com](http://www.sears.com)

---

To purchase a protection agreement (U.S.A.) or maintenance agreement (Canada) on a product serviced by Sears:

**1-800-827-6655** (U.S.A.)

**1-800-361-6665** (Canada)

---

Para pedir servicio de reparación a domicilio, y para ordenar piezas:

**1-888-SU-HOGAR<sup>SM</sup>**

(1-888-784-6427)

Au Canada pour service en français:

**1-800-LE-FOYER<sup>MC</sup>**

(1-800-533-6937)

[www.sears.ca](http://www.sears.ca)



® Registered Trademark / ™ Trademark / <sup>SM</sup> Service Mark of Sears, Roebuck and Co.

® Marca Registrada / ™ Marca de Fábrica / <sup>SM</sup> Marca de Servicio de Sears, Roebuck and Co.

<sup>MC</sup> Marque de commerce / <sup>MD</sup> Marque déposée de Sears, Roebuck and Co.

© Sears, Roebuck and Co.