

ARCTIC AIR COMMERCIAL REFRIGERATOR / FREEZER

Table of Contents

Product Registration	2
Important Safety Instructions	2
Electrical Information	2
Installation and Setup	3
Appliance Start-Up	4
Features	4
Routine Maintenance	5
Reversing Door	6
Energy Conservation Measures	7
Avoid Service Checklist	8
Wiring Diagram	10
If You Need Service	11
Warranty	12

Product Registration

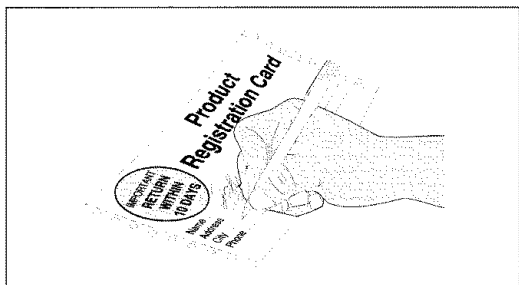

The information contained within this Owner's Guide will instruct you on how to properly operate and care for your product. Please read through the information contained in your literature pack to learn more about your new appliance.

Record Your Model and Serial Numbers

Record the Model No. and Serial No. of this appliance in the space provided below. The serial plate is located on the outside left wall of freezer.

Model No.: _____

Serial No.: _____

Register Your Product

The self-addressed PRODUCT REGISTRATION CARD (shown above) should be filled in completely, signed and returned to the address provided.

Important Safety Instructions

Read all instructions before using this appliance.

⚠ WARNING For Your Safety

Do not store or use gasoline or other flammable vapors and liquids in the vicinity of this or any other appliance. Read product labels for flammability and other warnings.

⚠ WARNING Child Safety

- Destroy carton, plastic bags, and any exterior wrapping material immediately after the freezer is unpacked. Children should never use these items to play. Cartons covered with rugs, bedspreads, plastic sheets or stretch wrap may become airtight chambers, and can quickly cause suffocation.
- Remove all staples from the carton. Staples can cause severe cuts, and destroy finishes if they come in contact with other appliances or furniture.
- An empty, discarded ice box, refrigerator, or freezer is a very dangerous attraction to children.

- Remove the door(s) of any appliance that is not in use, even if it is being discarded.
- Remove and discard any spacers used to secure the shelves during shipping. Small objects are a choke hazard to children.

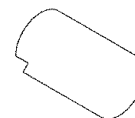

Proper Disposal of Your Refrigerator/Freezer

⚠ WARNING Risk of child entrapment. Child entrapment and suffocation are not problems of the past. Junked or abandoned refrigerators or freezers are still dangerous—even if they will sit for “just a few days.” If you are getting rid of your old refrigerator or freezer, please follow the instructions below to help prevent accidents.

BEFORE YOU THROW AWAY YOUR OLD REFRIGERATOR/FREEZER:

- Remove doors.
- Leave shelves in place so children may not easily climb inside.

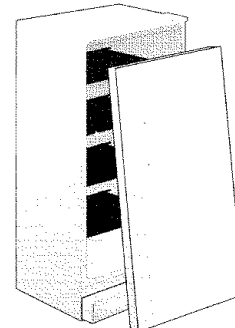

⚠ WARNING Avoid fire hazard or electric shock. Do not use an extension cord or an adapter plug. Do not remove any prong from the power cord.

Grounding type wall receptacle

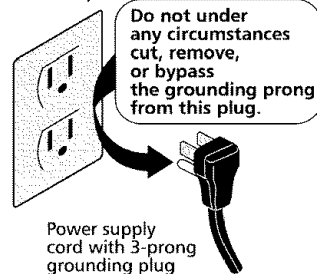

Power supply cord with 3-prong grounding plug

⚠ WARNING Electrical Information

These guidelines must be followed to ensure that safety mechanisms in the design of this appliance will operate properly.

- **Refer to the serial plate for correct electrical rating.** The power cord of the appliance is equipped with a three-prong grounding plug for protection against shock hazards. It must be plugged directly into its own properly grounded three-prong receptacle, protected with a 15 amp time delay fuse or circuit breaker. The receptacle must be installed in accordance with the local codes and ordinances. Consult a qualified electrician. Receptacles with Ground Fault Circuit Interrupters (GFCI) are NOT RECOMMENDED. **DO NOT use an extension cord or an adapter plug.**
- If voltage varies by 10 percent or more, appliance performance may be affected. Operating the appliance with insufficient power can damage the motor. Such damage is not covered under the warranty. If you suspect your voltage is high or low, consult your power company for testing.
- To prevent the appliance from being turned off accidentally, do not plug the unit into an outlet controlled by a wall switch or pull cord.
- Do not pinch, knot, or bend the power cord in any manner.

⚠ WARNING Other Precautions

- Never unplug the appliance by pulling on the power cord. Always grip the plug firmly and pull straight out from the receptacle.
- To avoid electrical shock, unplug the appliance before cleaning.

Note: Turning the control to OFF turns off the compressor, but does not disconnect power to other electrical components.

Installation and Setup

Inspection for Damage

Inspect the underside of the cabinet and packaging for damage such as a fork truck can cause, or look for bent base members from dropping the cabinet. If hidden damage is found after uncrating, immediately call the delivery carrier and request an inspection. Retain all packaging and crating materials until the inspection is complete.

Uncrate and Set Up

1. Remove carton and all loose parts from inside of freezer.
2. Tip unit onto its back.
3. Remove and discard the two wood skids from bottom and the four (4) washers. Keep the four (4) nuts. See following illustration.

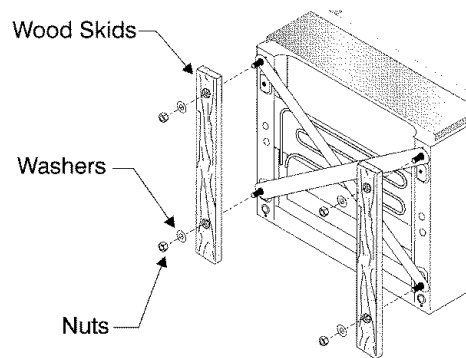

4. There are four casters in the caster kit. The pair of casters to be used in front have brakes. Place a caster with brakes over one of the bolts in front. Place one of the nuts on bolt to retain caster. Tighten securely.

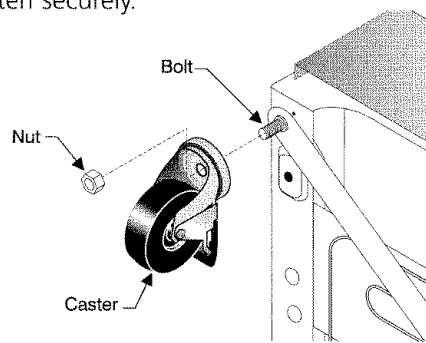

5. Repeat Step 4 for the other front caster, and then for the two rear casters. **Be sure to tighten each nut securely.**
6. With an assistant, tip unit up so it is standing upright on its casters. Roll unit to the place where it will be installed. If floor is not flat and level, unit may tip from side to side. If it does tip, the C-shaped washers can be used to shim unit up. They should be installed between caster and freezer base. Remember to securely tighten all nuts when unit installation is satisfactory.

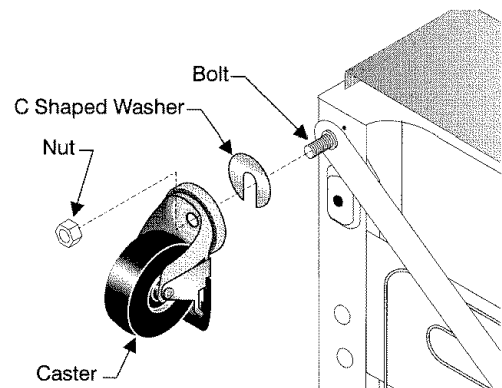

7. Installation is now complete.

Appliance Placement

Leave a three (3) inch space on all sides and the back of the cabinet for adequate air circulation. Choose a place that is near a grounded electrical outlet. For the most efficient operation, the appliance should be located where surrounding temperatures will not exceed 110°F (43°C). Appliance should not be operated in ambient below 32°F (0°C). Additional compressor heaters are not recommended.

Insulation

The insulated space of this cabinet is sealed to maintain peak efficiency. Holes drilled in the cabinet may destroy that seal and damage electrical wiring located in the insulated space.

DAMAGED ELECTRICAL WIRING OR WET INSULATION CAUSED BY DRILLING WILL VOID THE WARRANTY.

Appliance Start-Up

Once the appliance has been located in its permanent location and the proper power and grounding has been provided, the following items must be checked or completed:

Cool Down Period

For safe food storage, allow 24 hours for the appliance to cool down completely before loading with food. The appliance will run continuously for the first several hours. Do not place any food in the appliance until after the first 24 hours of operation.

Thermostat Settings

The appliance is shipped from the factory with the thermostat set at about the mid-point of the operating range. Adjustments colder or warmer can be made after the appliance has been running for at least 8 hours. Allow at least 8 hours for temperature stabilization before re-adjusting the thermostat.

Defrost Setting

The appliance is designed to defrost automatically every 12 hours. To set the time of defrost, wait until the desired time to defrost. With the notch on the timer knob aligned with the line on the bracket (Figure A), turn the defrost timer knob clockwise slowly. The timer will click several times, then once loudly, at which point the defrost cycle begins. The timer knob will advance through the defrost cycle, then click loudly at the end of the cycle (Figure B). The appliance will defrost automatically every 12 hours after the first defrost cycle.

For example, to set the appliance to defrost at 10:00 a.m., turn the timer knob clockwise at 10:00 a.m. until the timer clicks loudly. The appliance will defrost daily at 10:00 a.m. and again 12 hours later at 10:00 p.m. **Note:** The products' internal temperature will rise during the defrost cycle every 12 hours.

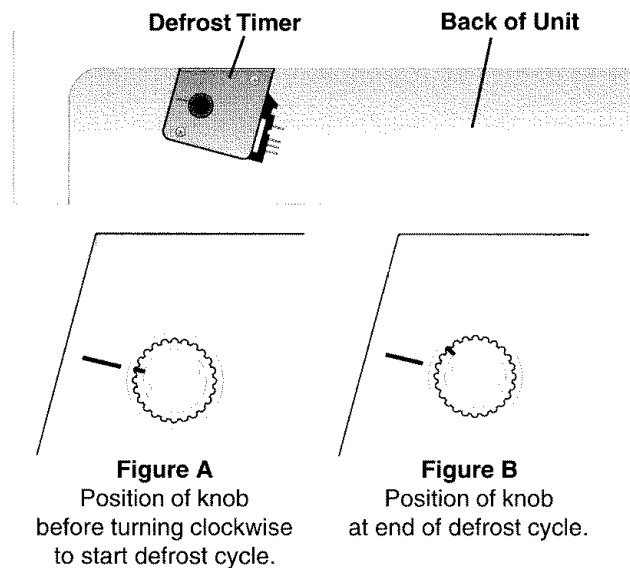

Features

- Heavy duty epoxy powder coated adjustable shelving
- Heavy duty commercial door lock
- 3 inches of door insulation
- NSF certified top mounted evaporator
- 2-1/2" urethane foam cabinet insulation
- Reversible door
- Spring loaded door closer
- Heavy duty swivel casters
- Stainless steel door edge guard and handle
- 40 watt shatterproof bulb
- Removable stainless steel drain cover
- Adjustable temperature control
- NSF certified interior
- Stainless steel evaporator housing
- Stainless steel toe plate
- Heavy duty commercially rated electrical harness
- Heavy duty removable stainless steel shelf supports

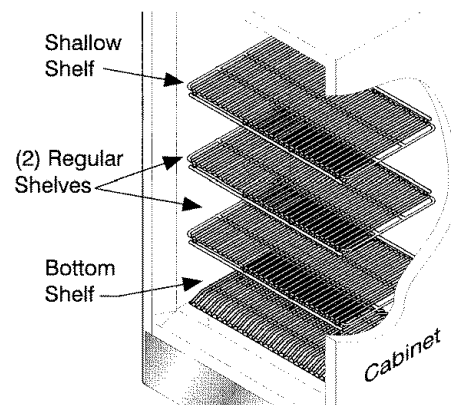

Shelves

The appliance is provided with 4 shelves. One goes on the floor of the cabinet and the other 3 are placed in the metal side supports wherever they are needed. The shallow shelf goes in the upper position.

4 Swivel Casters

The appliance comes with 4 swivel casters; 2 with locks for front of unit and 2 without locks, for the back of the unit. The casters allow the appliance to be moved with ease, and then locked into place upon final destination. (Refer to page 3 for instructions.)

Reversible Door Lock

The appliance comes with an outer cabinet mounted door lock and two keys. The lock can be mounted on either side of the appliance depending on which side the door swings open. A door mounted lock guard has been provided for added security. (Refer to page 7 for instructions.)

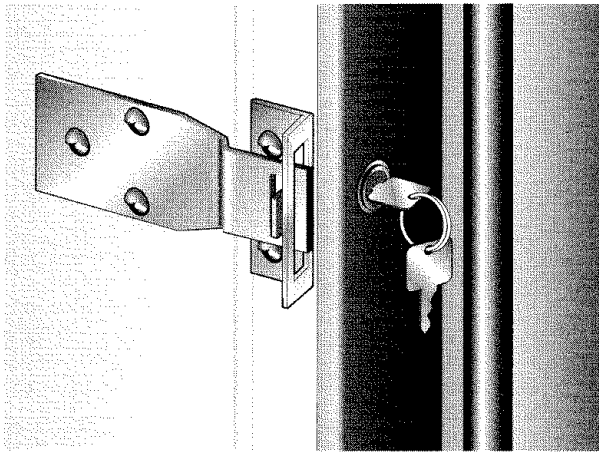

Reversible Door

The door can be reversed (See Routine Maintenance section) to provide either a right-hand swing or a left-hand swing.

Adjustable Temperature Control

The adjustable thermostat control is located on the top left panel inside the unit.

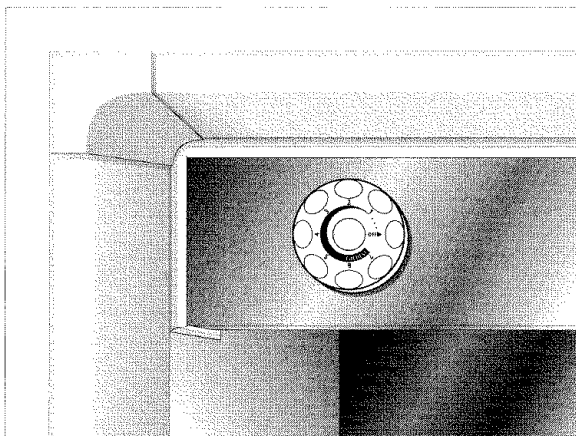

Interior Thermometer

The appliance comes with a thermometer to show internal temperatures. The thermometer is to be hung from the top adjustable shelf on the right hand side.

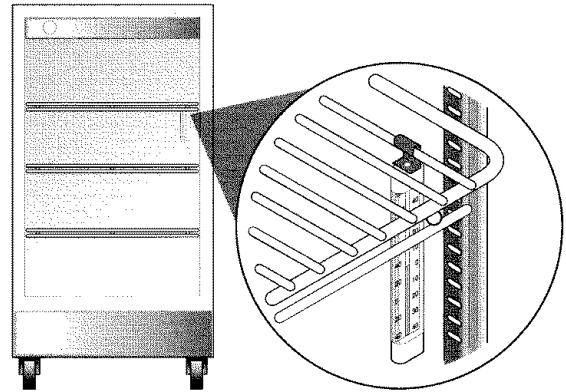

Interior Light

The appliance is equipped with a 40 watt bulb that lights up when the door is opened. If bulb goes bad replace with bulb of same type and wattage. This is a special bulb with a shatterproof coating. Use an NSF certified bulb of the same type and wattage (can be ordered from your Arctic Air Service Center at 1-800-490-9574 / P/N 2163600900).

Routine Maintenance

Cleaning the Interior

Be sure to turn the temperature control to off and unplug the electrical cord. Wash the inside surface of the storage area with warm water and baking soda solution (about one tablespoon of baking soda per quart of water). Rinse thoroughly with clean, warm water and wipe dry. The procedure can also be used for cleaning the door gasket. Wipe the stainless steel cover plates with Magic Clean Stainless Steel Cleaner (can be ordered from your Arctic Air Service Center at 1-800-490-9574 / P/N 218490900) or some other stainless steel cleaner.

Cleaning the Exterior

Wipe the textured cabinet exterior occasionally with a cloth dampened in mild detergent and water, rinse and wipe dry with a soft cloth. Wipe the stainless steel door plate and toe grill with Magic Clean Stainless Steel Cleaner or some other stainless steel cleaner. Do not use razor blades or other sharp instruments that can scratch the appliance surface when removing adhesive labels. Any glue left from the tape can be removed with a mixture of warm water and mild detergent or touch the residue with the sticky side of tape already removed. **DO NOT REMOVE THE SERIAL PLATE.**

Condensate Pan

The condensate pan is in a fixed position and must not be removed from under the cabinet. If the pan is removed, condensate will drip onto the floor.

Reversing Door

This appliance features a door that can provide either a left hand or right hand opening. It comes from the factory in the right hand position.

Follow these steps to reverse the opening:

1. With the appliance in a standing upright position, open the door and remove the toe plate (2 screws in the upper corners).
2. Slightly loosen the two hex spacers that the toe plate screws were screwed into.

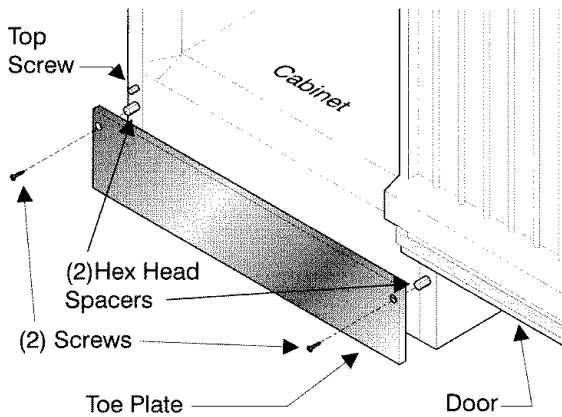

3. Holding door securely closed, remove three (3) hex head screws from the top hinge and flat spacer.
4. Lift appliance door off of bottom hinge and set aside in a safe place (so it does not fall)

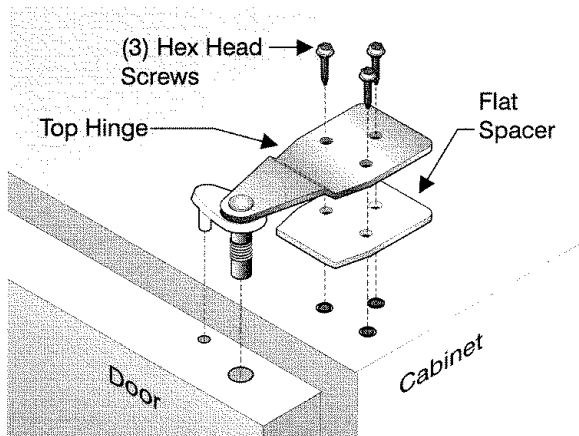

5. Remove top screw from bottom hinge. Remove top screw from opposite side of appliance.

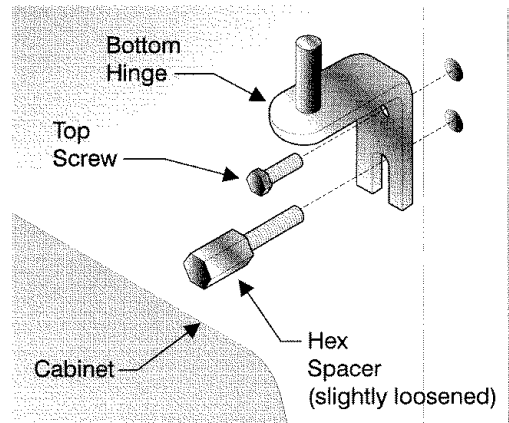

6. Slide bottom hinge onto hex spacer and attach top screw to cabinet. Retighten both hex spacers.

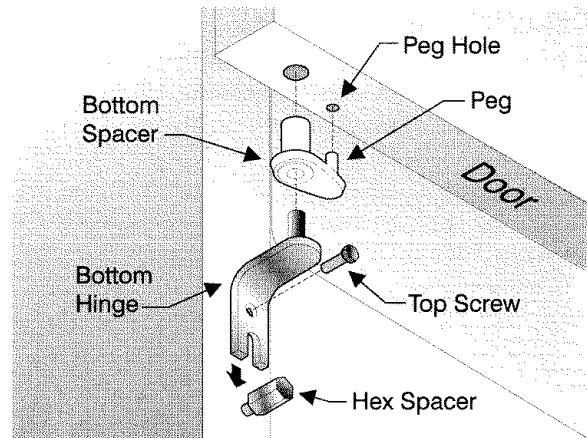

7. Remove the top hinge assembly and the bottom spacer from the door and reverse their position, making sure the pegs are properly seated in the peg holes.
8. Rotate the door 180° and re-install on bottom hinge. Hold door in closed position.

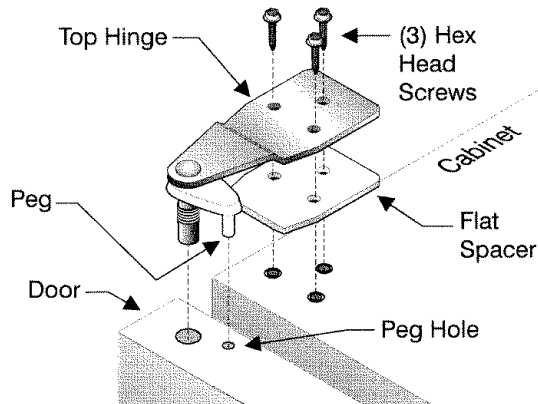

9. Rotate the top hinge to align the mounting holes. Re-position the flat spacer between the hinge and cabinet and install the three (3) hex head screws.
10. Install hole plugs in each of the hinge holes on opposite side of cabinet.
11. Re-install toe plate with two (2) screws.

Door Lock

Note: The lock strike should angle out and away from the cabinet.

1. Install the lock strike on the lock side of the cabinet, using the three (3) tamper resistant screws. Install the three remaining buttons in the holes on the opposite side of the cabinet.
2. Install the lock guard in the side of the door cabinet by installing the two screws into the corresponding screw holes.

CAUTION The tamper resistant screws cannot be removed after the lock strike is secured to the cabinet.

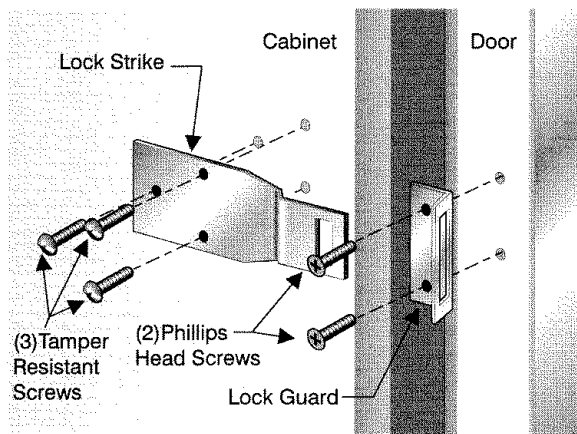

Energy Conservation Measures

The appliance is designed for efficiency with heavy foam insulation. However, there are things that the user can do to maintain the appliance in operating condition:

1. Do not operate the appliance any colder than necessary to maintain safe, product storage temperatures.
2. Make sure the appliance is located to prevent direct exposure to sunlight, air ducts, etc.
3. Keep the door closed except for normal use. Inspect the door often to see that it self-closes and the gasket is in good condition.
4. Do not overstock the product in the cabinet because it will block the normal air flow.
5. Have at least annual inspections by a qualified service company to see that the fan motor is functioning properly and that the refrigerant charge is correct.
6. This appliance operates more efficiently in a cooler ambient than in a hot ambient. Try to maintain an ambient below 80°F (27°C) and 65% RH for maximum efficiency.

Avoid Service Checklist

Before calling for service, review this list. It may save you both time and expense. This list includes common occurrences that are not the result of defective workmanship or materials in this appliance.

OCCURRENCE

SOLUTION

APPLIANCE DOES NOT RUN

- Appliance may be in defrost cycle, and the compressor and fan will not run.
- Temperature control is in the OFF position.
- Appliance may not be plugged in or plug may be loose. Be sure plug is tightly pushed into electrical outlet.
- Fuse has blown, or circuit breaker has tripped. Check/reset circuit breaker or replace fuse with 15 amp. time delay fuse.
- Power outage. Check lights. Call local electric company.

Appliance runs too much or too long.

- Room or outside weather is hot. It is normal for the appliance to work harder under these conditions.
- Appliance had recently been disconnected for a period of time. Appliance requires 24 hours to cool down completely.
- Large amounts of warm or hot food have been stored recently. Warm food will cause the appliance to run more until the desired temperature is reached.
- Door is kept open too long or too frequently. Warm air enters the appliance every time the door is opened. Open the door less often.
- Appliance door may be slightly open. See Occurrence section "Door Problems."
- Temperature control is set too cold. Turn the control knob to a warmer setting. Allow several hours for the temperature to stabilize.
- Appliance gasket is dirty, worn, cracked, or poorly fitted. Clean or change gasket. Leaks in the door seal will cause appliance to run longer in order to maintain desired temperature.

Temperatures inside the appliance are too cold.

- Temperature control is set too cold. Turn the control to a warmer setting. Allow several hours for the temperature to stabilize.

Temperatures inside the appliance are too warm.

- Temperature control is set too warm. Turn the control to a colder setting. Allow several hours for the temperature to stabilize.
- Door is kept open too long or is opened too frequently. Warm air enters the appliance every time the door is opened. Open the door less often.
- Door may be open slightly. See Occurrence section "Door Problems."
- Large amounts of warm or hot food may have been stored recently. Wait until the appliance has had a chance to reach its selected temperature.
- Appliance has recently been disconnected for a period of time. Appliance requires 24 hours to cool down completely.
- The products internal temperature will rise during the defrost cycle.

Temperature of external appliance surface is warm.

- Appliance cabinet is warm to the touch. Appliance is operating normally, removing warm air from the inside.

OCCURRENCE

SOLUTION

SOUND AND NOISE	
Louder sound levels whenever appliance is on.	<ul style="list-style-type: none">• Today's appliances have increased storage capacity and a more even temperature. They require a high speed compressor. This is normal.
Louder sound levels when compressor comes on.	<ul style="list-style-type: none">• Appliance operates at higher pressures during the start of the ON cycle. This is normal. Sound will level off or disappear as appliance continues to run.
Popping or cracking sound when compressor comes on.	<ul style="list-style-type: none">• Metal parts undergo expansion and contraction, as in hot water pipes. This is normal. Sound will level off or disappear as appliance continues to run.
Bubbling or gurgling sound, like water boiling.	<ul style="list-style-type: none">• Refrigerant (used to cool appliance) is circulating throughout the system. This is normal.
Vibrating or rattling noise.	<ul style="list-style-type: none">• Appliance is not level. It rocks on the floor when it is moved slightly. Install leveling washers to shim up the appliance.• Floor is uneven or weak. Appliance rocks on the floor when it is moved slightly. Be sure floor can adequately support appliance.• Appliance is touching the wall. Re-level the appliance or move appliance slightly.
WATER/MOISTURE/FROST INSIDE APPLIANCE	<ul style="list-style-type: none">• Weather is hot and humid, which increases internal rate of frost build-up. This is normal.
Moisture forms on inside appliance walls.	<ul style="list-style-type: none">• Door is slightly open. See Occurrence section "Door Problems."• Door is kept open too long or is opened too frequently. Open the door less often.
WATER/MOISTURE/FROST OUTSIDE APPLIANCE	<ul style="list-style-type: none">• Door is slightly open, causing the cold air from inside the appliance to meet warm moist air from outside. See Occurrence section "Door Problems."
Moisture forms on outside of appliance.	
ODOR IN APPLIANCE	<ul style="list-style-type: none">• Interior needs to be cleaned. Clean interior with sponge, warm water, and baking soda.• Foods with strong odors are in the appliance. Cover the food tightly.
DOOR PROBLEMS	
Door will not close	<ul style="list-style-type: none">• Appliance is not level. It rocks on the floor when it is moved slightly. This condition can force the cabinet out of square and misalign the door.• Floor is uneven or weak.
LIGHT BULB IS NOT ON	<ul style="list-style-type: none">• Light bulb is burned out. Follow directions under "Interior Light" in Appliance Features.• No electric current is reaching the appliance. See Occurrence section "Appliance Does Not Run."

Wiring Diagrams

Refrigerator Electrical Circuit

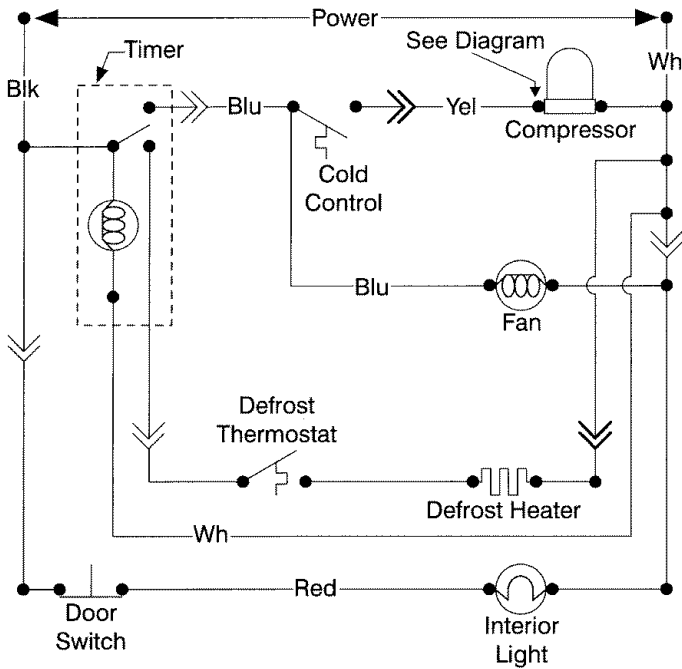

EC79

Refrigerator Diagram

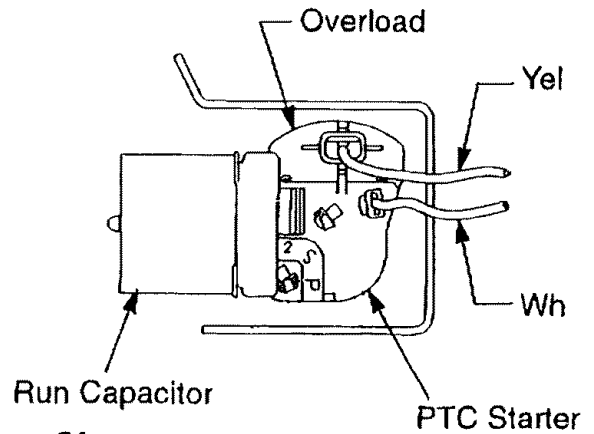

C1

IMPORTANT

If any green grounding wires are removed during servicing, they must be returned to their original position and properly secured.

Freezer Electrical Circuit

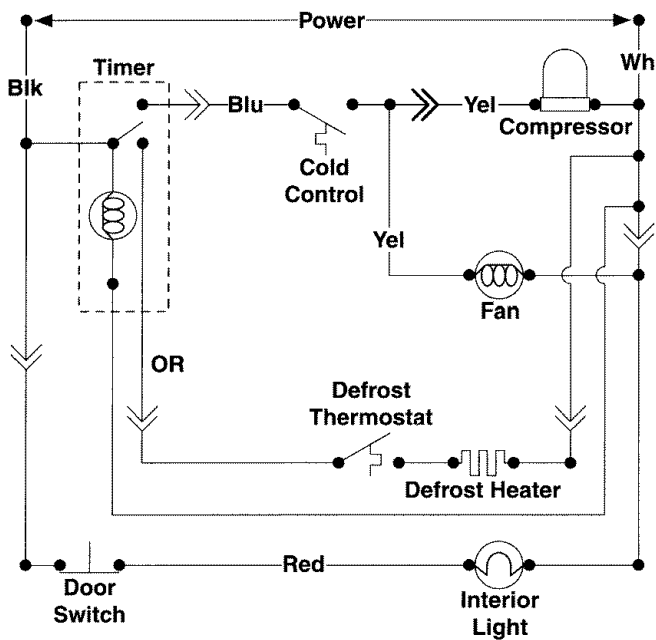

EC80

Freezer Diagram

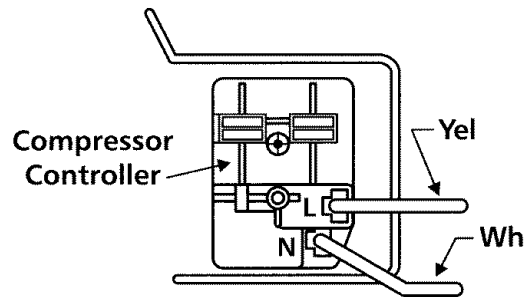

C28

IMPORTANT

If any green grounding wires are removed during servicing, they must be returned to their original position and properly secured.

If You Need Service . . .

Avoid Unnecessary Cost and Inconvenience

Make a few simple checks before calling for service. Common occurrences and their solutions can be found in the "**Avoid Service Checklist**" included in this owner's guide.

If Service Is Necessary

Keep your bill of sale, delivery slip, or some other appropriate payment record. The date on the bill establishes the warranty period should service be required. If service is performed, it is in your best interest to obtain and keep all receipts. This written warranty gives you specific legal rights. You may also have other rights that vary from state to state. Service under this warranty must be obtained by contacting your ARCTIC AIR CUSTOMER SERVICE CENTER:

In the United States: **800•490•9574**

In Canada: **866•294•9911**

ARCTIC AIR COMMERCIAL REFRIGERATOR/FREEZER WARRANTY

ARCTIC AIR (Division of Broich Enterprises, Inc.) warrants every new refrigerator and freezer to be free from defects in material or workmanship for a period of **one (1) year** (except as noted in the Special Mobile Use Warranty below) from the earliest of either: 1) the date of original purchase or; 2) fifteen (15) months after the manufacturer's ship date of the product (warranty period).

This warranty provides:

A. PARTS WARRANTY

ARCTIC AIR will, at its option, repair or replace any part(s), that are found defective during the warranty period. In addition, **ARCTIC AIR** warrants that the **compressor** shall be free from defects for an additional **four (4) years** beyond the expiration of the warranty period or for a total period of **five (5) years**.

Warranty replacement parts must be arranged by calling the **Customer Service Center** at **1-800-490-9574** (in the United States and Puerto Rico) and **1-866-294-9911** (in Canada).

B. LABOR WARRANTY

ARCTIC AIR will, at its option, provide or pay for the labor to repair or replace the part(s) or product defect during the warranty period. Warranty labor must be arranged by calling the **Customer Service Center** at **1-800-490-9574** (in the United States and Puerto Rico) and **1-866-294-9911** (in Canada).

C. SPECIAL MOBILE USE WARRANTY

ARCTIC AIR warrants every new refrigerator and freezer operated by a concessionaire or vendor in a trailer, motorized vehicle or at varying locations for a period of **one (1) year** for the part(s) and **ninety (90) days** for labor to repair or replace, at **Arctic Air's** option, the warranty part(s). In addition, **ARCTIC AIR** warrants that the **compressor** shall be free from defects for a total period of **five (5) years**. This warranty will be effective with the earliest of either: 1) the date of original purchase or ; 2) fifteen (15) months after the manufacturer's ship date of the product. Any labor to remove or expose or make the refrigerator or freezer available for service under this warranty shall be at the user's expense.

D. CONDITIONS

Service under this warranty must be performed by a preferred service company arranged by the **Customer Service Center** at **1-800-490-9574** (in the United States and Puerto Rico) and **1-866-294-9911** (in Canada). The user must give the preferred service company prompt notice and access to the product when service is needed.

E. LIMITATIONS AND EXCLUSIVE WARRANTY

Normal wear and tear and gradual deterioration is excluded from this warranty. This parts and labor warranty is the sole and exclusive warranty remedy offered by **ARCTIC AIR**. **ALL OTHER WARRANTIES, EITHER EXPRESS OR IMPLIED, ARISING UNDER LAW OR EQUITY OR CUSTOM OF THE TRADE INCLUDING BUT NOT LIMITED TO WARRANTIES OR MERCHANTABILITY OR FITNESS FOR A PARTICULAR PURPOSE ARE EXCLUDED. NEITHER ARCTIC AIR NOR ITS SERVICING AGENT SHALL BE LIABLE FOR ANY INCIDENTAL OR CONSEQUENTIAL LOSS OR DAMAGES (INCLUDING BUT NOT LIMITED TO FOOD OR PRODUCT LOSS, PERSONAL INJURY OR PROPERTY DAMAGE) WHETHER BASED ON CONTRACT OR TORT (INCLUDING NEGLIGENCE AND STRICT LIABILITY) ARISING OUT OF THE EQUIPMENT OR SERVICE PROVIDED HEREUNDER. THIS WARRANTY DOES NOT APPLY TO ARCTIC AIR PRODUCTS SOLD OUTSIDE THE UNITED STATES, CANADA, OR PUERTO RICO. THIS WARRANTY DOES NOT COVER:**

- **FREIGHT DAMAGE**
- **FOOD LOSS**
- **NON-FACTORY APPROVED REVISIONS OR MODIFICATIONS**