

INSTALLATION MANUAL

SEALED GAS COOKTOPS CCG2423 AND CCG2523 JGC7430 AND JGC7536

JENN-AIR

403 WEST FOURTH STREET, NORTH • NEWTON, IA 50208

IMPORTANT: Dimensions Shown in Both Inches and Centimeters.

IMPORTANT: Be sure the appliance being installed is equipped for the gas to be supplied. Refer to serial plate on underside of burner box for this information. Do not attempt to convert this appliance for use with a gas other than the type specified.

30" MODEL

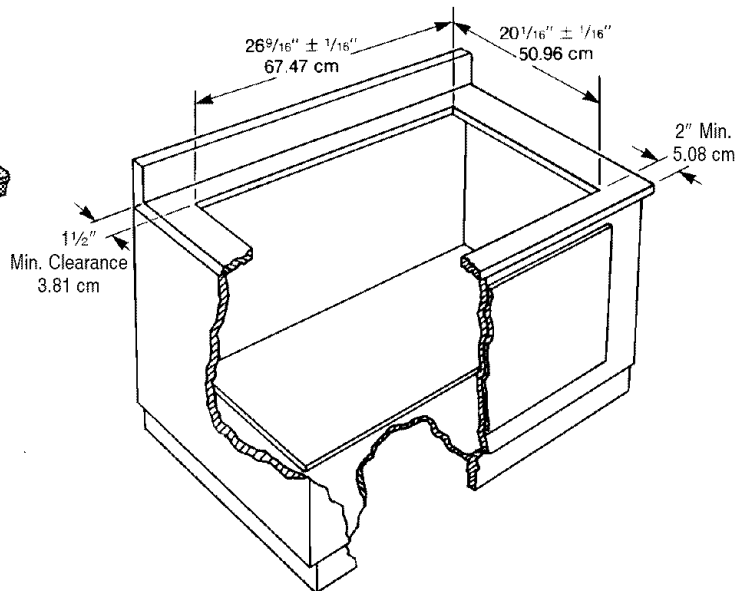
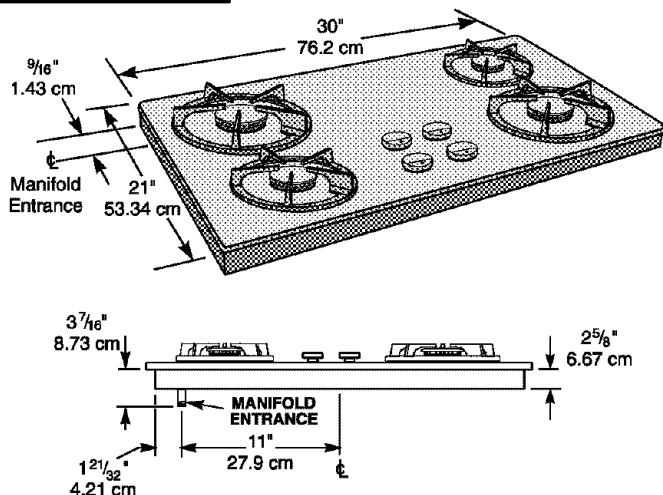

36" MODEL

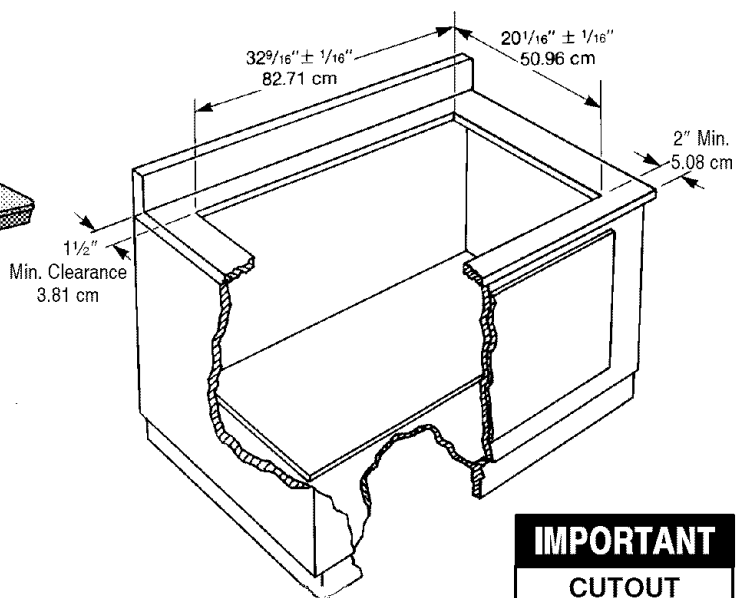
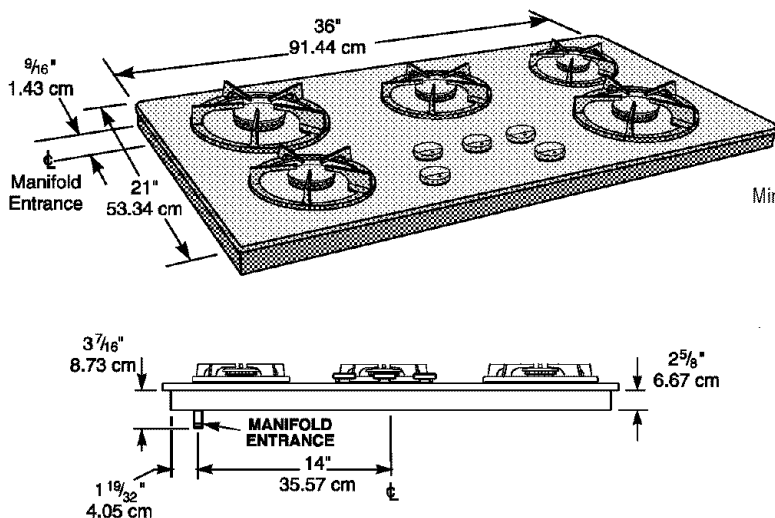

IMPORTANT
CUTOUT
DIMENSIONS
ARE
CRITICAL



SPECIAL WARNING: Improper installation, adjustment, alteration, service, maintenance or use of appliance can result in serious injury or property damage.

NOTICE TO INSTALLER: LEAVE THESE INSTRUCTIONS WITH THE APPLIANCE.
NOTICE TO CONSUMER: RETAIN THESE INSTRUCTIONS FOR FUTURE REFERENCE.

8101P401-60
(08-01-00)

LOCATION OF YOUR JENN-AIR APPLIANCE

Locate this appliance away from combustible materials such as window curtains and combustible wall decorations.

Minimum horizontal clearance between the edge of the appliance and combustible construction extending from the cooking surface to 18" (45.72 cm) above the cooking surface is

1" (2.54 cm) at rear
4" (10.16 cm) at sides

(Dimensions apply to both 30" and 36" wide models)

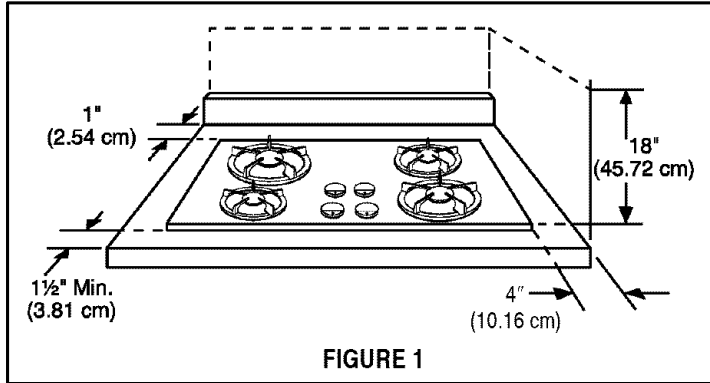

INSTALLING CABINETRY OVER YOUR JENN-AIR COOKTOP

A = 30" (76.2 cm) minimum vertical clearance between cooking surface and construction above the appliance. This clearance may be reduced to not less than 24 inches (60.96 cm) by protecting the underside of the combustible material or metal cabinet above the cooking surface with not less than 1/4 inch (.635 cm) insulating millboard covered with sheet metal not less than 0.0122 inch thick*

B = 13" (33.02 cm) maximum depth of cabinets installed above cooking top.

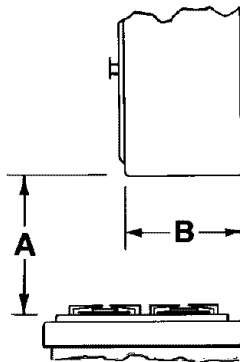

Avoid use of cabinets above cooktop for storage space to eliminate associated potential hazards such as reaching over open flames.

PREPARATION OF COUNTERTOP

The countertop cutout must be prepared according to the illustration on page 1 of these instructions.

CAUTION: Cutout dimensions are critical. Dimensions must be measured and cut accurately to within $\pm 1/16"$ (.159 cm) to ensure proper fit.

* Jenn-Air Over-the-Range microwave ovens (model #M418 and M438) have been listed by UL for use over Gas and Electric Ranges. When properly installed at a minimum height of 66 inches (167.64 cm) from the floor to the top of the microwave, the clearance to the cooking surface at the center will be 13-3/4 inches (34.93 cm).

IMPORTANT PREPARATION SUGGESTIONS

1. Chamfer all exposed edges of decorative laminate to prevent damage from chipping.
2. Radius corners of cutout and file to insure smooth edges and prevent corner cracking.
3. Rough edges, inside corners which have not been rounded and forced fits can contribute to cracking of the countertop laminate.
4. Countertop must be supported within 3" (7.62 cm) of cutout.

INSTALLATION OF APPLIANCE

The installation of this appliance must conform with local codes or, in the absence of local codes, with the National Fuel Gas Code, ANSI Z223.1-Latest Edition, or, in Canada, CAN/CGA-B149 Installation Code, Latest Edition.

This appliance, when installed, must be electrically grounded in accordance with local codes or, in the absence of local codes, with the National Electrical Code ANSI/NFPA No. 70-Latest Edition, or, in Canada, current CSA Standard C22.1 Canadian Electrical Code, Part 1.

All supply piping, except as noted, should use common National Pipe Thread (N.P.T.). For all pipe connections use an approved pipe joint compound resistant to the action of LP gas.

CAUTION: Warranty is void on Jenn-Air equipment installed other than as recommended by manufacturer.

This appliance is designed for use with the appliance gas pressure regulator supplied with this appliance. It must be installed in the gas way ahead of the gas manifold entrance. It is preset for use with natural gas and must be converted, as described on page 6, for use with LP gas. (See figures 10 and 11.)

This appliance is designed to operate at a pressure of 5 inches of water column on natural gas or, if converted for use with LP gas (propane or butane), 10 inches water column. Make sure this appliance is supplied with and adjusted for the type of gas for which it is designed.

This appliance was adjusted at the factory for use with natural gas. If, at any time, this appliance is to be used with a different type of gas, all of the conversion adjustments described on pages 5 and 7 must be made by a qualified service technician before attempting to operate the cooktop on that gas. Natural gas should be supplied to the appliance pressure regulator at a line pressure between 6 and 14 inches of water column or, if converted for LP gas, between 11 and 14 inches.

WARNING: If the line pressure supplying the appliance pressure regulator exceeds 14" W.C. (any gas), an external regulator must be installed in the gas line ahead of the appliance regulator to reduce the pressure to no more than 14" W.C. Failure to do this can result in malfunction and damage to the appliance.

Insure this appliance is adjusted for the type of gas supplied to it and that the gas supply pressure to the appliance regulator is within the proper pressure range.

- If this is a 36" wide model, or if it is a 30" wide model and no other appliance is to be installed in the cabinetry below it, proceed as instructed under paragraph I.
- If this is a 30" wide model and a Jenn-Air Model W30XXX or W131 Electric Wall Oven is to be installed in cabinetry below, proceed as instructed under paragraph II.
- Do not remove protective cap from pipe stub at manifold entrance until ready to join gas supply piping to appliance.

NOTE: In Canada, gas utilization codes prohibit use of street elbows. Use standard pipe elbows and make modifications to these instructions as necessary.

CONNECTING APPLIANCE TO GAS SUPPLY

A TRAINED SERVICEMAN OR GAS APPLIANCE INSTALLER MUST MAKE THE GAS SUPPLY CONNECTION. Leak testing of the appliance shall be conducted by the installer according to the instructions given.

1. IF NO OTHER APPLIANCE IS TO BE INSTALLED BELOW THIS COOKTOP

Join the appliance pressure regulator supplied with this appliance to the entrance threads of the Gas Manifold. The appliance regulator is marked with a directional arrow indicating correct direction of gas flow. Ensure the appliance regulator is installed with the arrow pointing toward the gas manifold entrance. Tighten the appliance regulator to 20 to 30 ft-lbs of torque.

IMPORTANT

Never tighten to more than 35 ft-lbs of torque. Always use an approved pipe joint compound resistant to the action of LP gas.

Install the appliance in its counter cutout.

Make the gas connection to the inlet of the appliance pressure regulator with 1/2" male pipe threads.

Install a manual shut-off valve in an accessible location in the gas line ahead of the appliance pressure regulator and external to this appliance for the purpose of turning on or shutting off gas to the appliance.

Make additional pipe connections as necessary ahead of the shut-off valve to the gas supply source. Assure all pipe joint connections are gas tight.

IMPORTANT

Apply a non-corrosive leak detection fluid to all joints and fittings in the gas connection between the supply line shut-off valve and the range. Include gas fittings and joints in the range if connections were disturbed during installation. Check for leaks! Bubbles appearing around fittings and connections will indicate a leak. If a leak appears, turn off supply line gas shut-off valve, tighten connections, turn on the supply line gas shut off valve, and retest for leaks. Never test for gas leaks with an open flame.

ILLUSTRATIVE GAS SUPPLY PIPING

(NO OTHER APPLIANCE BELOW COOKTOP)

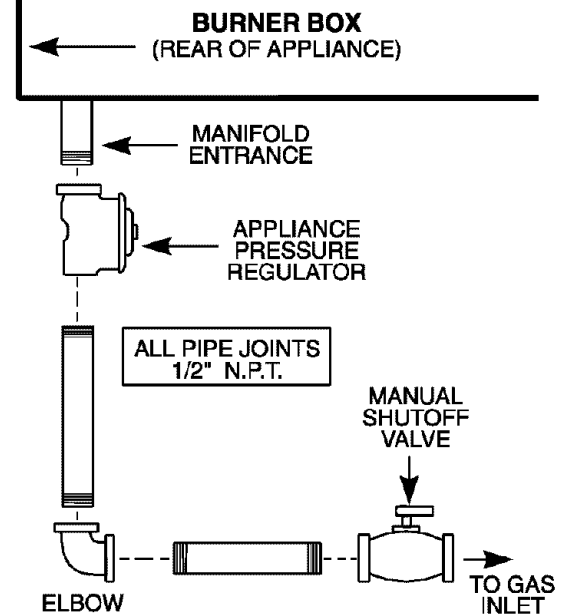

2. IF THIS IS A 30" WIDE COOKTOP AND A JENN-AIR, MODEL W30XXX OR W131, ELECTRIC WALL OVEN IS TO BE INSTALLED BELOW THIS COOKTOP.

NOTE 1: This appliance and its gas and electrical supply sources must be installed before the wall oven is installed. See illustration (Electrical Wiring Information - page 4; figure 6) for recommended electrical supply source locations.

NOTE 2: It may be necessary to extend gas supply piping for this appliance into adjacent under-counter cabinetry when a wall oven is installed below this appliance.

Join a 1/2" NPT pipe elbow (locally available) to the male threads at the manifold entrance. When joined, cause the open threads of the elbow to face toward the left side of the appliance. Install the appliance in its counter cutout.

Join a 1/2" NPT pipe nipple to the elbow using a pipe section of sufficient length to extend, horizontally, beyond the left side of the wall oven. (To accomplish this it may be necessary to extend the pipe section into adjacent cabinetry.) Join additional 1/2" NPT elbow(s) and pipe nipples, as necessary, to accomplish the following:

Join the outlet of the appliance pressure regulator supplied with this appliance to the male threads of the newly installed gas supply piping. Install the appliance regulator in a location which will be accessible beside or below the wall oven. Insure the appliance regulator is installed with its directional arrow pointing in the direction of gas flow. Tighten the appliance regulator to 20 to 30 ft-lbs of torque.

IMPORTANT

Never tighten to more than 35 ft-lbs of torque. Always use an approved pipe joint compound resistant to the action of LP gas.

Locate and join a manual shut-off valve in an accessible location in the gas line ahead of the appliance regulator and external to the appliance for the purpose of turning on or shutting off gas to the appliance.

Make additional pipe connections as necessary ahead of the shut-off valve to the gas supply source. Assure all pipe joint connections are gas tight.

IMPORTANT

Apply a non-corrosive leak detection fluid to all joints and fittings in the gas connection between the supply line shut-off valve and the range. Include gas fittings and joints in the range if connections were disturbed during installation. Check for leaks! Bubbles appearing around fittings and connections will indicate a leak. If a leak appears, turn off supply line gas shut-off valve, tighten connections, turn on the supply line gas shut off valve, and retest for leaks. Never test for gas leaks with an open flame.

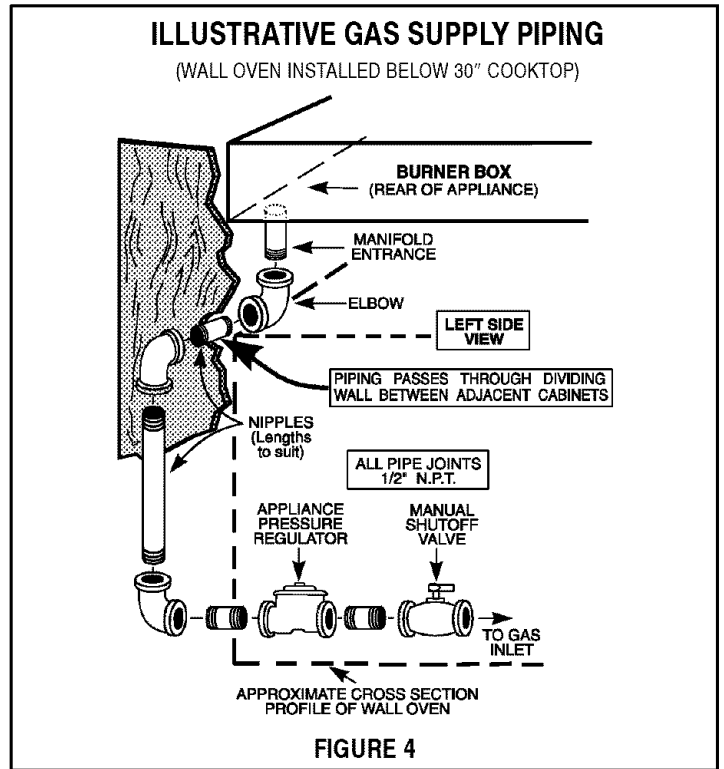

FIGURE 4

Note, regarding Figure 4, above:

- For convenience in service a ground joint union (not shown: locally available) should be included in the piping illustrated in figure 4, in a location most practical for the installation. Generally, a practical location is in the cabinet below this appliance, near the manifold entrance, rather than in an adjoining cabinet.
- If the alternative piping method shown in figure 5 is selected for the installation, no ground joint union is required. (The flexible appliance connector illustrated provides the union joints necessary for servicing.) When a dividing wall is present and a flexible connector is used it is recommended for convenience, in both installation and service, the flexible connector, itself, pass through the dividing wall. **Any flexible connector used with this appliance must satisfy all requirements stated in the text accompanying figure 5.**

ALTERNATIVE PIPING METHODS TO CONNECT APPLIANCE TO GAS SUPPLY

A TRAINED SERVICEMAN OR GAS APPLIANCE INSTALLER MUST MAKE THE GAS SUPPLY CONNECTION. Leak testing of the appliance shall be conducted by the installer according to the instructions given.

Unless prohibited by local codes or ordinances, a new A.G.A. - Certified, flexible metal appliance connector may be used to connect this appliance to its gas supply. The connector must have an internal diameter not less than nominal 1/2" NPT pipe and be no more than 5 feet in length. A 1/2" NPT x 1/2" flare union adaptor is required at each end of the flexible connector. If a flexible connector is used assure that both the appliance pressure regulator and manual shut-off valve are joined solidly to other permanent hard piping (either gas supply or the appliance manifold) so as to be physically stationary. See illustrations below:

CAUTION: Do not attempt to attach the flexible connector directly to an external pipe thread. Connection requires flare union adapters.

IMPORTANT

Apply a non-corrosive leak detection fluid to all joints and fittings in the gas connection between the supply line shut-off valve and the range. Include gas fittings and joints in the range if connections were disturbed during installation. Check for leaks! Bubbles appearing around fittings and connections will indicate a leak. If a leak appears, turn off supply line gas shut-off valve, tighten connections, turn on the supply line gas shut off valve, and retest for leaks. Never test for gas leaks with an open flame.

PRESSURE TESTING

The appliance must be isolated from the gas supply piping system by closing its individual manual shut-off valve during any pressure testing of the gas supply piping system at test pressures equal to or less than 1/2 PSIG (3.5 kPa).

This appliance, as well as its individual shut-off valve, must be disconnected from the gas supply piping system during any pressure testing of the system at test pressures in excess of 1/2 PSIG (3.5 kPa).

When checking appliance regulator function, make certain pressure of natural gas supply is between 6 and 14 inches of water column or, if converted for LP gas, between 11 and 14 inches.

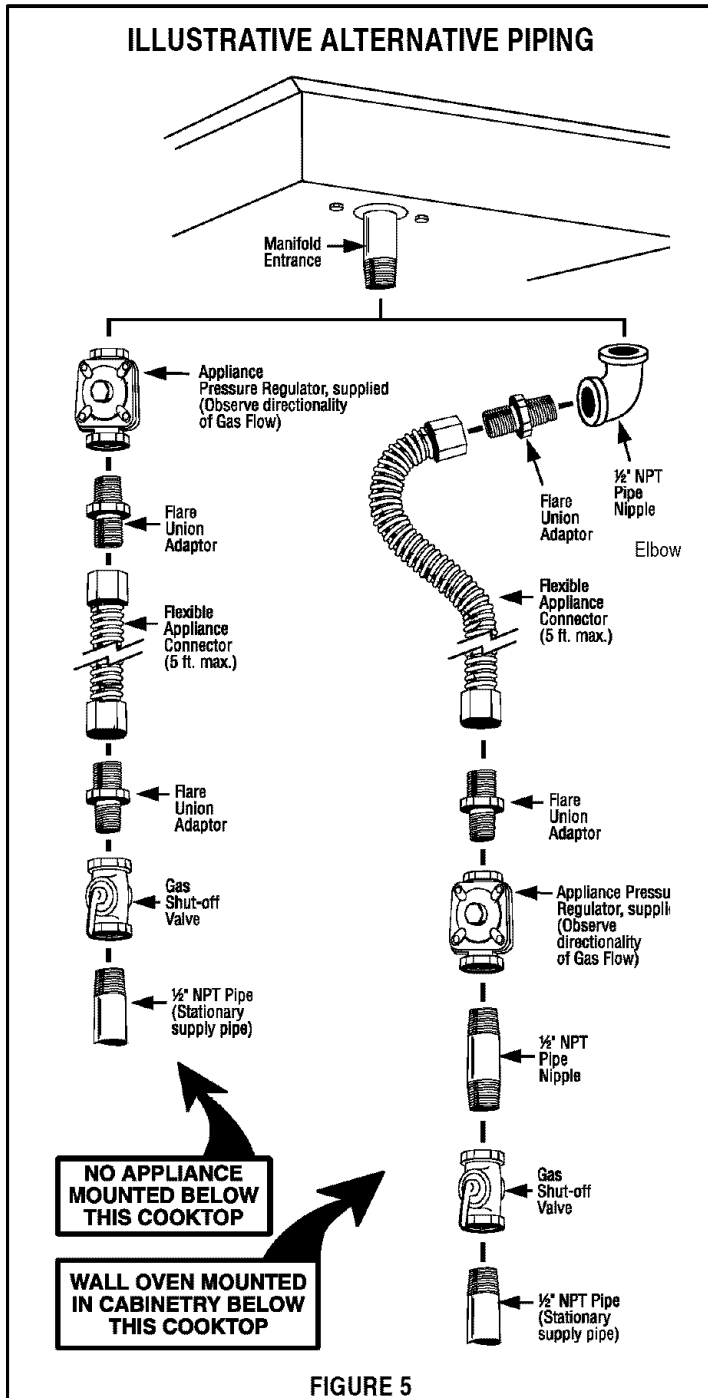

FIGURE 5

ELECTRICAL WIRING INFORMATION

This appliance is equipped with a grounded type power cord. A grounded outlet must be provided. It is recommended, for convenience, the outlet be located (with reference to figure 6) as in A or B, below:

- A. If no other appliance is to be installed below this appliance: within either the shaded area or the cross hatched area shown in figure 6.
- B. If a Model W30XXX or W131 electric oven is to be installed below this appliance, either:
 1. within the cross hatched area of figure 6, or,
 2. within an adjacent cabinet.

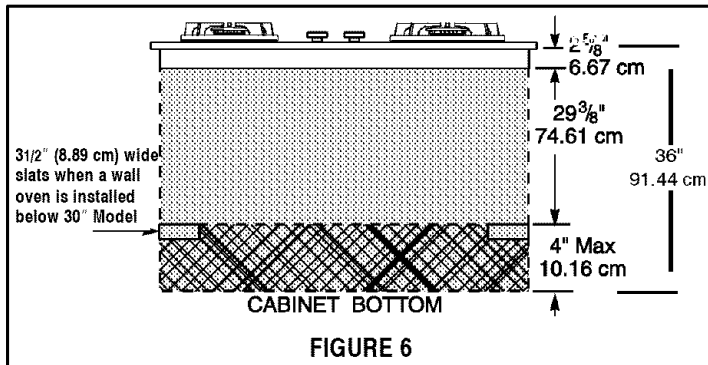

FIGURE 6

Dimension A:

W30XXX: 5-1/2" (13.97 cm)

W131: 4" (10.16 cm)

If a wall oven is to be installed below this appliance and the counter unit's outlet is to be mounted within the cross hatched area of figure 6:

1. The cabinet's lower front panel, below the oven, must be made removable for access to the outlet.
2. A clearance hole for the power cord's plug (1-1/4" (3.18 cm) dia is recommended) must be provided through the oven's floor support shelf

and, if necessary, through the slats supporting the shelf. The clearance hole should be located as near as practical to the rear of the shelf and (if the oven is model W30XXX) as near as practical to the left rear corner.

3. When model W30XXX is mounted below this appliance, and if the power outlet for this appliance is to be located in the cross hatched area of figure 6, it is recommended the power cord be routed through the external vertical clearance channel at the left rear of the oven. The channel's cross section is approximately 4.2" x 2.25" (10.7 x 5.7 cm), extending the full height of the oven. (Model W131 provides a similar, but larger, vertical channel near the center of the main back of the oven.)

If the outlet is to be mounted in either a left or right adjacent cabinet, a clearance hole, as described above, must be provided in the dividing wall between the cabinets. Figure 4; page 3, illustrates a typical (left side) dividing wall. The clearance hole (not shown in figure 4) can be located as is convenient in this left wall or in the corresponding right wall.

In planning any installation, note that the free length of this appliance's power cord, extending beyond a point 3-3/4" (9.53 cm) left of the nominal center of the rear wall of the burner box, when viewed from the front of the unit, is approximately 46" (117 cm).

WARNING

ELECTRICAL GROUNDING INSTRUCTIONS

THIS APPLIANCE IS EQUIPPED WITH A THREE PRONG GROUNDING PLUG FOR YOUR PROTECTION AGAINST SHOCK HAZARD AND SHOULD BE PLUGGED DIRECTLY INTO A PROPERLY GROUNDED RECEPTACLE. DO NOT CUT OR REMOVE THE GROUNDING PRONG FROM THIS PLUG.

WARNING

THIS APPLIANCE MUST BE DISCONNECTED FROM ITS ELECTRICAL SUPPLY AT THE WALL RECEPTACLE BEFORE SERVICING THE APPLIANCE.

CONVERTING APPLIANCE FOR USE WITH LP GAS

WARNING

Propane conversion is to be performed by a JENN-AIR AUTHORIZED SERVICER (or other qualified agency) in accordance with the manufacturer's instructions and all codes and requirements of the authority having jurisdiction. Failure to follow instructions could result in serious injury or property damage. The qualified agency performing this work assumes responsibility for this conversion.

WARNING

Electrical power and gas must be turned off prior to conversion.

This appliance was adjusted at the factory for use with natural gas. To convert it for use with LP gas (propane or butane), each of the following modifications must be performed:

A. Replace all orifice spuds

- Step 1: Remove the grates and burner heads.
- Step 2: Remove aluminum venturi tube.
- Step 3: Trim a small piece of masking tape to the size of a dime and affix it over the end of a 5/16" nut driver.
- Step 4: Firmly press the nut driver over the orifice spud (figure 7) and loosen spud by turning counterclockwise. Carefully lift nut driver out of burner throat. Orifice spud should be captured in the recess. Repeat this step for each burner.

REMOVAL OF ORIFICE SPUD

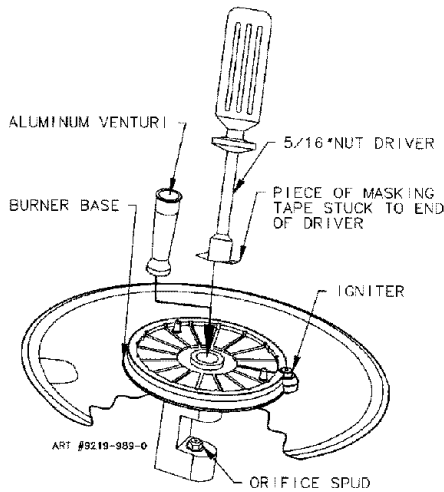

FIGURE 7

- Step 5: Locate the LP orifice spud packet taped to the underside of the burner box. The spuds have small numbers stamped on the side. This number codes the orifice diameter and its correct burner location. The following illustrations show correct LP orifice spud location for 4 burner and 5 burner models, respectively.

INSTALLATION OF LP ORIFICE SPUDS

4 BURNER MODEL (30" WIDE)

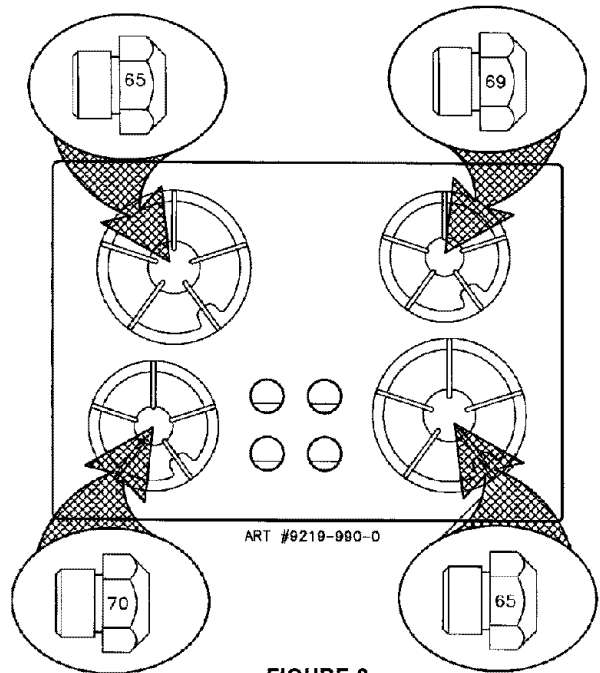

FIGURE 8

5 BURNER MODEL (36" WIDE)

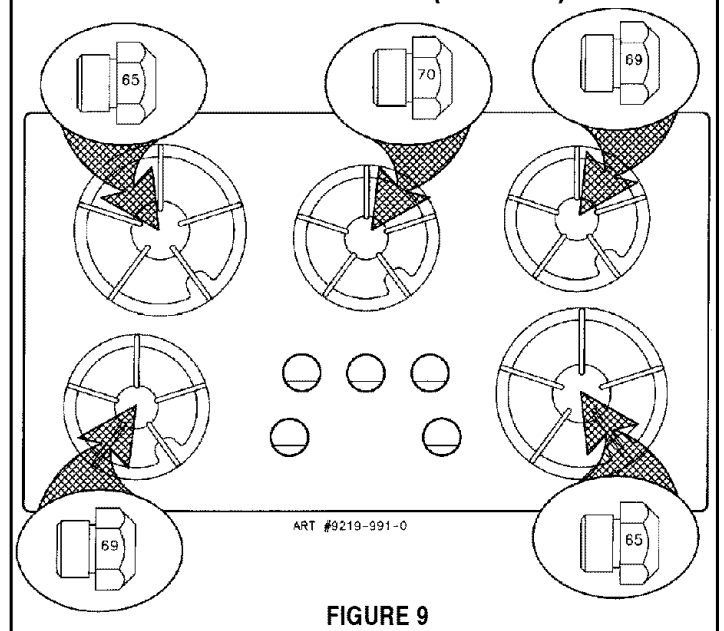

FIGURE 9

- Step 6: With the masking tape still in place in the recess of the nut driver, press an LP orifice spud into the recess so that it is snugly captured.
- Step 7: Carefully install the orifice spud in the appropriate burner throat by turning clockwise to tighten. Tighten to a torque of 15 to 20 inch-lbs.
- Step 8: Replace cylindrical aluminum venturi tubes. Replace burner heads and grates. Index each grate to its burner pan.
- Step 9: Save the orifices removed from the appliance for future use.

B. Invert cap in appliance pressure regulator

(See figures 10 and 11.)

With the appliance installed, the appliance regulator should be located as shown in figure 3 or 4. Identify the type of appliance regulator on the unit and follow the instructions in the appropriate illustration.

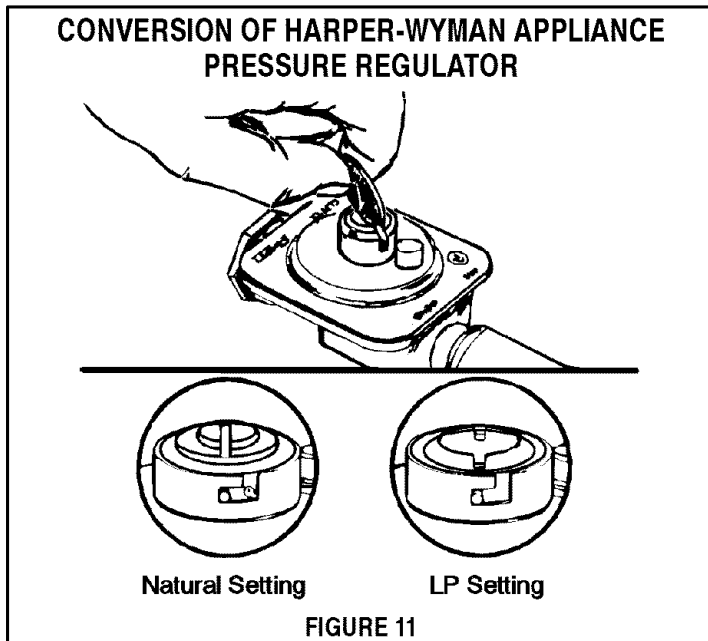
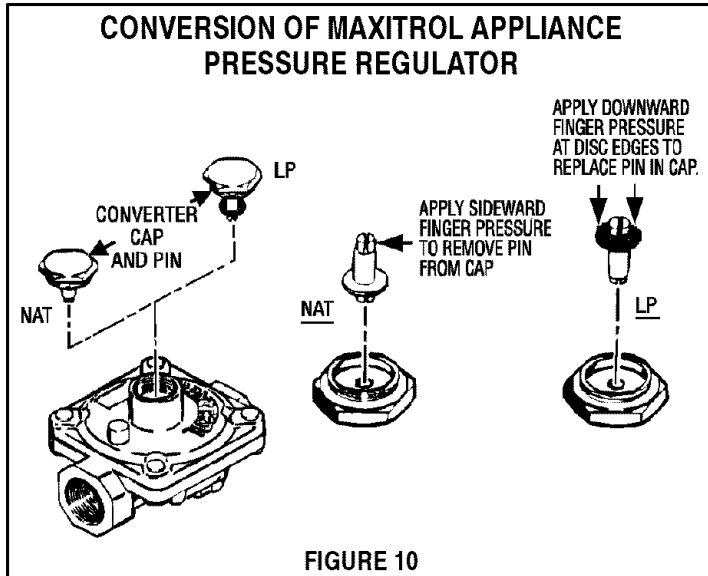

C. Low Flame Adjustment

(See figure 12.)

This appliance is shipped from the factory with low and medium flame settings adjusted for use with natural gas. If further adjustment is necessary, or to readjust for use with LP, proceed as follows:

1. Light burner and set control knob for low flame.
2. Remove control knob from valve stem.

CAUTION: NEVER USE A METAL BLADE TO PRY KNOB OFF. IF KNOB CANNOT BE EASILY REMOVED, TUCK THE FOLDS OF A CLOTH DISHTOWEL UNDER THE KNOB AND PULL THE TOWEL UPWARD WITH STEADY, EVEN PRESSURE.

3. Insert a slender, thin-blade screwdriver into the recess at center of valve stem and engage blade with slot in adjusting screw.
4. Turn center stem adjusting screw to set flame size.
 - ... clockwise to reduce
 - ... counterclockwise to increase
5. Replace control knob when adjustment is completed.

Proper adjustment will produce a stable, steady blue flame of minimum size. The final adjustment should be checked by turning knob from high to low several times without extinguishing the flame.

This adjustment, at low setting, will automatically provide the proper flame size at medium setting.

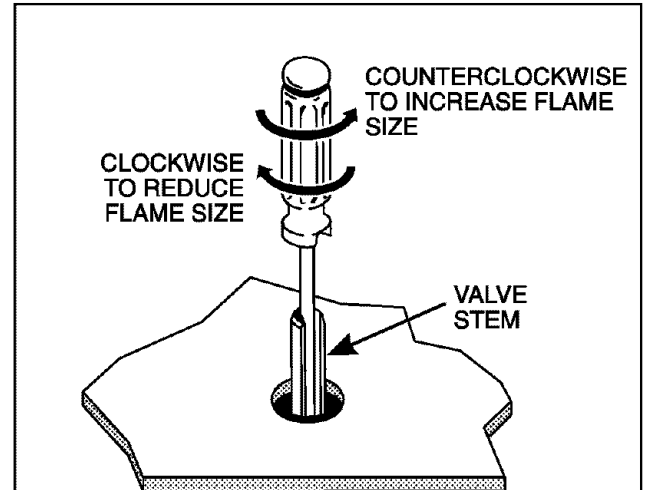

After Conversion Steps A, B and C have been completed, check the appearance of each burner's flame at the Hi and Lo settings against figure 13. If the flames appear too large or too small, review each step to make sure it was completed correctly.

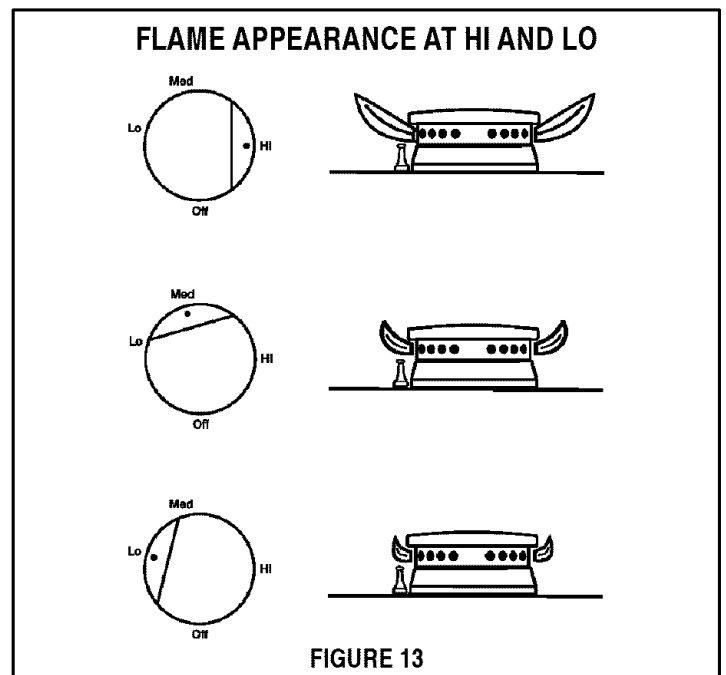

TO CONVERT APPLIANCE FOR USE WITH NATURAL GAS

WARNING

Electrical power and gas must be turned off prior to conversion.

If this appliance has been converted for use with LP gas, each of the following modifications must be performed to convert the unit back to natural gas.

A. Replace all orifice spuds

Perform Steps 1 through 4 on page 5.

For Step 5: Locate the colored brass natural gas orifice spuds that were originally installed in this appliance before its conversion for use with LP gas. Observe the color of each of the spuds and note the correct burner location for each spud as shown in figures 14 and 15.

Complete Steps 6 through 9 on page 5 to complete the installation of natural gas main spuds in their correct locations.

Save the orifices removed from the appliance for future use. They will be needed if this appliance is again converted for use with LP gas.

B. Invert cap in appliance pressure regulator.

(See figures 10 and 11.)

With the appliance installed the appliance regulator should be located as shown in either figure 3 or figure 4 (page 3). Identify the type of appliance regulator and follow the instructions in the appropriate illustration.

C. Adjust low flame as instructed on page 6 item C.

After Steps A, B and C have been completed, check the appearance of each burner's flame at the Hi and Lo settings against figure 13. If the flames appear too large or too small, make sure all steps were completed correctly.

INSTALLATION OF NATURAL GAS ORIFICE SPUDS

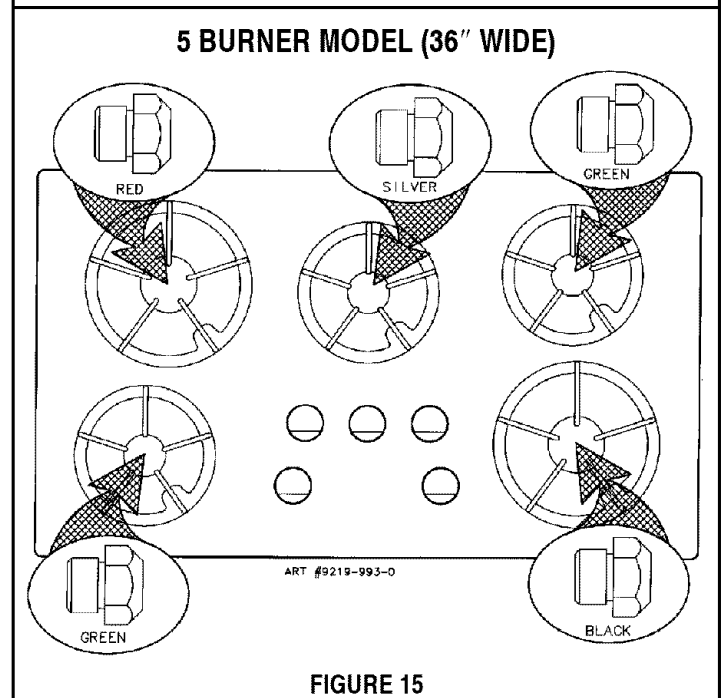
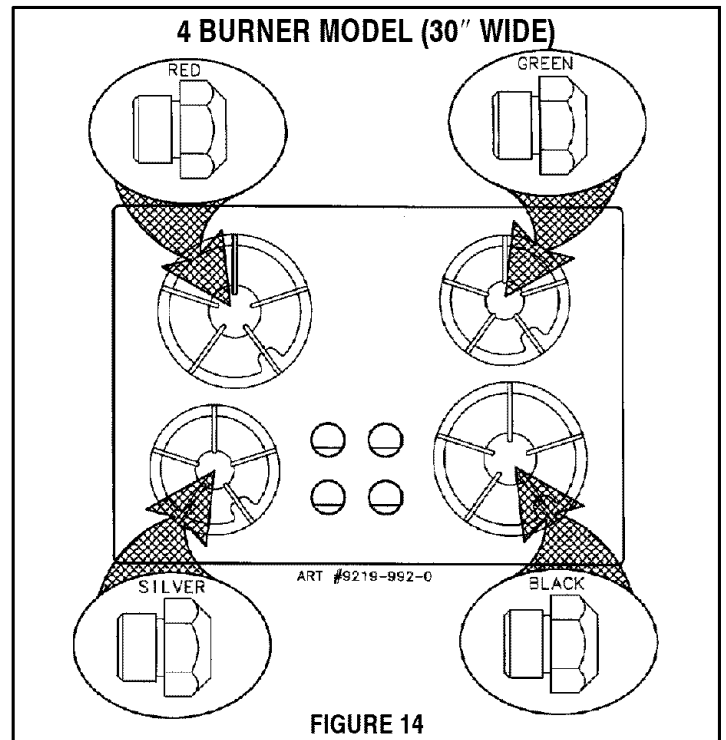

BURNER IGNITION AND AUTO-REIGNITION

This appliance is equipped for electronic auto-reignition by means of a spark igniter located at the rear of each burner. The burners are designed to light at any valve rotation that admits sufficient gas flow to support a flame and to automatically relight following a loss of flame due to a draft or other adverse condition. This feature is provided as a convenience and is not intended as a safety feature.

CAUTION: Never use a metal blade to pry off a control knob. If a knob cannot be easily removed tuck the folds of a cloth dishtowel under and around the knob and pull the towel upward with steady even pressure.

CAUTION: Never cover control knobs or surrounding control surface with utensils, towels, or other objects. Never obstruct free air passage past the control knobs. The knob openings have been sized to properly control air entry to the interior of the appliance during operation.

This appliance has no air shutters. Primary air adjustments are unnecessary. The burners are designed to provide optimum aeration for all gases without air shutters. When operating properly, burners should produce clearly defined, even blue flames. If the flames have yellow tips or are hazy and otherwise appear to have insufficient air, obtain the services of a qualified service technician.

Specified input rates are as shown in figures 16 and 17, below.

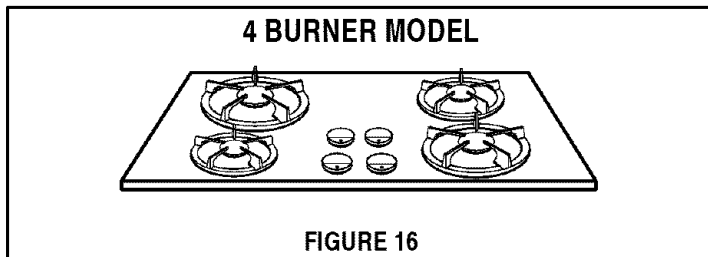

BURNER LOCATION	INPUT RATES - NATURAL GAS (BTU/HR)	
	Hi	Lo
Right Front	12,000	1,500
Right Rear	9,100	1,050
Left Front	6,500	830
Left Rear	10,500	1,500

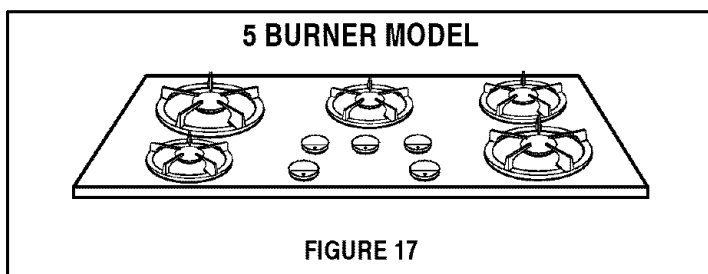

BURNER LOCATION	INPUT RATES - NATURAL GAS (BTU/HR)	
	Hi	Lo
Right Front	12,000	1,500
Right Rear	9,100	1,050
Center	6,500	830
Left Front	9,100	1,050
Left Rear	10,500	1,500

TOP GRATE REPLACEMENT

The top grates on this cooktop have underside projection lugs designed to nest in matching depressions in the spillover trays. During grate placement always position grates to make this engagement. Correct indexing of grates above burner ports will preserve the grates' appearance and help assure long life.

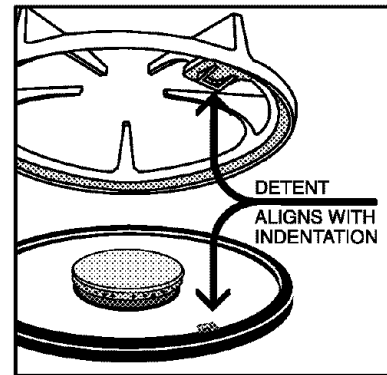

REQUIRED ADJUSTMENTS AT TIME OF INSTALLATION

The installation of this appliance must conform with local codes, or in the absence of local codes, with the latest edition of the National Fuel Gas Code ANSI Z223.1 USA or current CAN/CGA-B149 INSTALLATION CODE.

- This appliance was manufactured for use with Natural Gas. If LP gas is the fuel of choice, follow the conversion to LP procedure found in the installation instructions.
- Test all external connections for gas leaks. Never test for gas leaks with an open flame.
- Test all electrical connections.