

PRO-FORM®

CARDIO GLIDE PLUS

Model No. PFCG2224.0

Serial No. _____

Write the serial number in the space above for future reference.

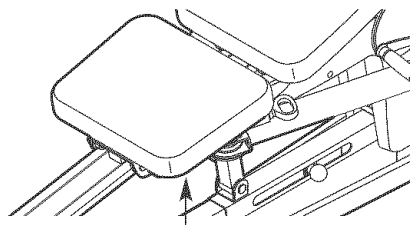

Serial Number Decal (Under Seat)

QUESTIONS?

As a manufacturer, we are committed to providing complete customer satisfaction. If you have questions, or if a part is damaged or missing, PLEASE CONTACT OUR CUSTOMER SERVICE DEPARTMENT DIRECTLY.

CALL TOLL-FREE:

1-888-533-1333

Mon.–Fri., 6 a.m.–6 p.m. MST

ON THE WEB:

www.proformservice.com

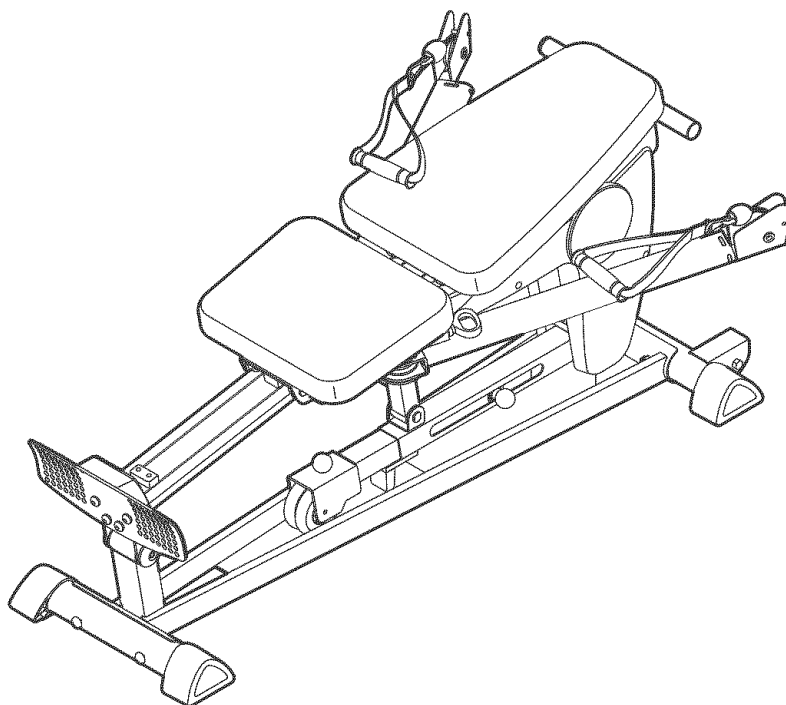

USER'S MANUAL

CAUTION

Read all precautions and instructions in this manual before using this equipment. Save this manual for future reference.



Visit our website at

www.proform.com

*new products, prizes,
fitness tips, and much more!*

TABLE OF CONTENTS

WARNING DECAL PLACEMENT	2
IMPORTANT PRECAUTIONS	3
BEFORE YOU BEGIN	4
ASSEMBLY	5
ADJUSTMENTS	8
WEIGHT RESISTANCE CHART	12
EXERCISE GUIDELINES	13
ORDERING REPLACEMENT PARTS	Back Cover
LIMITED WARRANTY	Back Cover

Note: A PART IDENTIFICATION CHART and a PART LIST/EXPLODED DRAWING is attached in the center of this manual. Remove the PART IDENTIFICATION CHART and PART LIST/EXPLODED DRAWING before beginning assembly.

WARNING DECAL PLACEMENT

The decal shown here has been placed on the exercise bench. If the decal is missing or illegible, please call the toll-free telephone number on the front cover of this manual and order a free replacement decal. Apply the decal in the location shown.

▲ WARNING

- Misuse of this machine may result in serious injury.
- Read user's manual prior to use and follow all warnings and instructions.
- Do not allow children on or around machine.
- Keep body, clothing, and hair free and clear of all moving parts.
- Replace label if damaged, illegible, or removed.

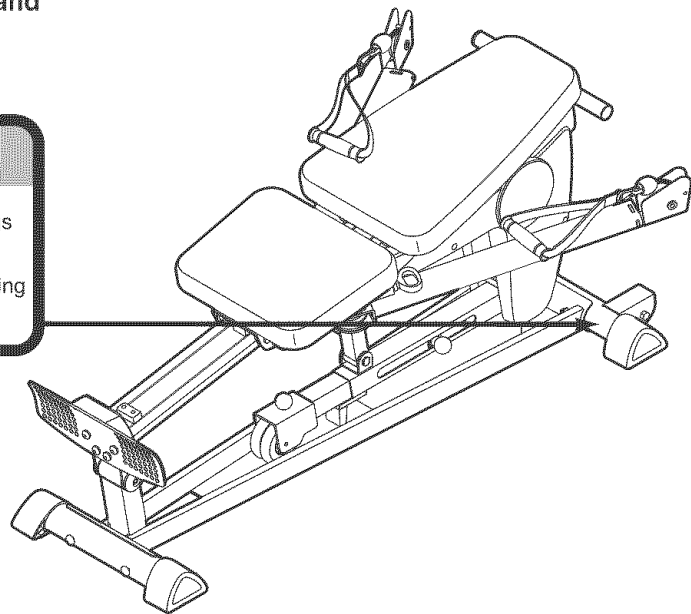

IMPORTANT PRECAUTIONS

⚠ WARNING: To reduce the risk of serious injury, read the following important precautions before using the exercise bench.

1. Read all instructions in this manual and all warnings on the exercise bench before using the exercise bench. Use the exercise bench only as described in this manual.
2. It is the responsibility of the owner to ensure that all users of the exercise bench are adequately informed of all precautions.
3. The exercise bench is intended for home use only. Do not use the exercise bench in any commercial, rental, or institutional setting.
4. Keep the exercise bench indoors, away from moisture and dust. Place the exercise bench on a level surface, with a mat beneath it to protect the floor or carpet. Make sure that there is enough clearance around the exercise bench to mount and dismount the exercise bench and to perform the intended exercises.
5. Make sure all parts are properly tightened each time the exercise bench is used. Replace any worn parts immediately.
6. Keep children under 12 and pets away from the exercise bench at all times.
7. Keep hands and feet away from moving parts.
8. Always wear athletic shoes for foot protection while exercising.
9. The exercise bench is designed to support a maximum user weight of 250 pounds.
10. The exercise bench is designed to use the user's weight as the resistance. Do not use the exercise bench with dumbbells or any other type of weight to increase the resistance.
11. Always make sure the backrest frame is fully engaged before using the backrest.
12. Make sure that the rope remains on the pulleys at all times. If the rope binds as you are exercising, stop immediately and make sure that the rope is on the pulleys. Replace the rope at least every two years.
13. If you feel pain or dizziness at any time while exercising, stop immediately and begin cooling down.

⚠ WARNING: Before beginning this or any exercise program, consult your physician. This is especially important for persons over the age of 35 or persons with pre-existing health problems. Read all instructions before using. ICON assumes no responsibility for personal injury or property damage sustained by or through the use of this product.

BEFORE YOU BEGIN

Thank you for selecting the versatile PROFORM® CAR-DIO GLIDE PLUS exercise bench. The exercise bench is designed to develop every major muscle group of the body. Whether your goal is to tone your body, build dramatic muscle size and strength, or improve your cardio-vascular system, the exercise bench will help you to achieve the specific results you want.

For your benefit, read this manual carefully before using the exercise bench. If you have questions after reading this manual, see the front cover of this manual. To help us assist you, please note the product model number and serial number before calling. The

model number is PFCG2224.0. The serial number can be found on a decal attached to the exercise bench (see the front cover of this manual for the location of the decal).

To avoid a registration fee for any service needed under warranty, you must register the exercise bench at www.proformservice.com/registration.

Before reading further, please review the drawing below and familiarize yourself with the parts that are labeled.

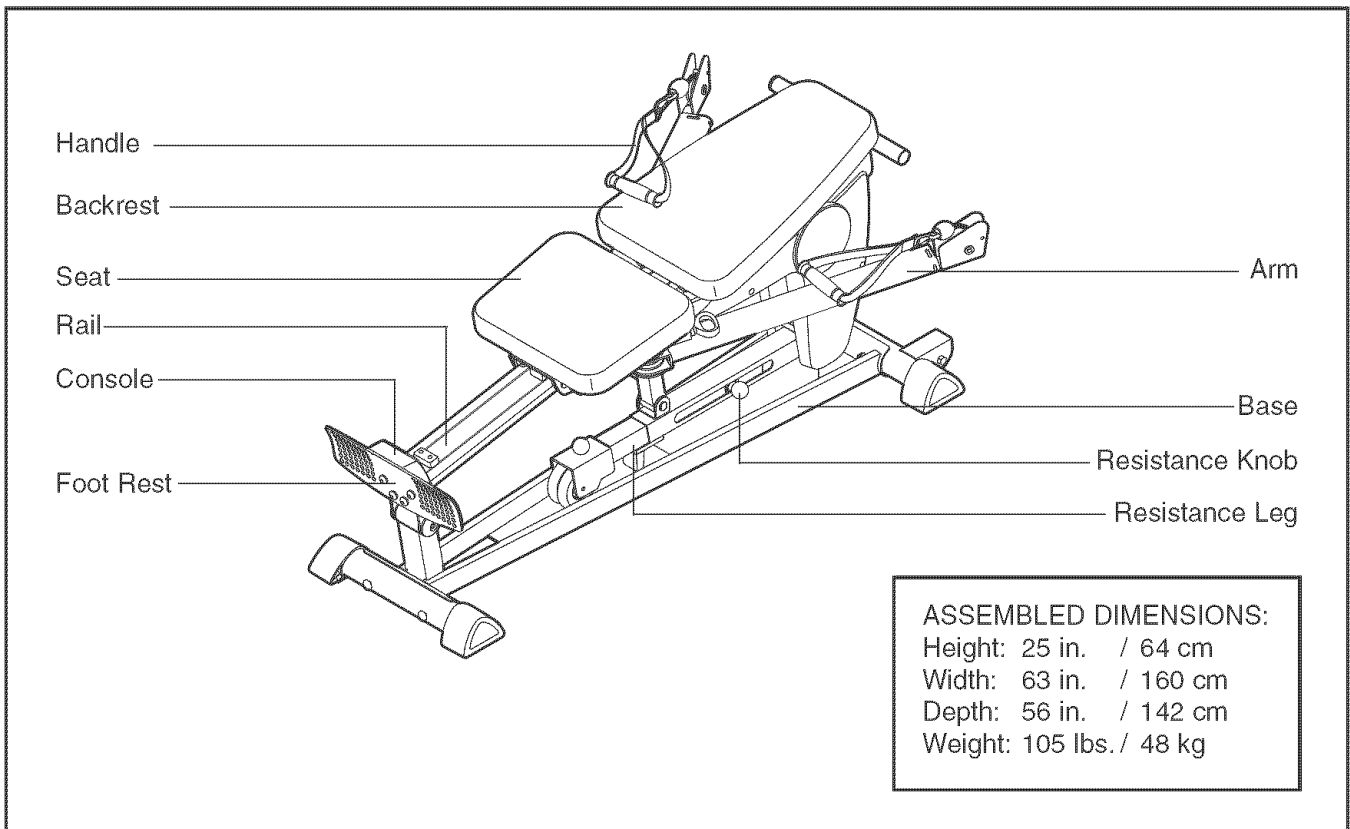

ASSEMBLY

Make Things Easier for Yourself

Everything in this manual is designed to ensure that the weight bench can be assembled successfully by anyone. Most people find that by setting aside plenty of time, assembly will go smoothly.

To hire an authorized service technician to assemble the exercise bench, call toll-free 1-800-445-2480.



Before beginning assembly, carefully read the following information and instructions:

- Assembly requires two people.
- Tighten all parts as you assemble them, unless instructed to do otherwise.
- Place all parts in a cleared area and remove the packing materials. Do not dispose of the packing materials until assembly is completed.

- As you assemble the weight bench, make sure all parts are oriented as shown in the drawings.

- **For help identifying small parts, use the PART IDENTIFICATION CHART.**

The included hex key(s) , and the following tools (not included) may be required for assembly:

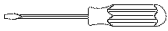
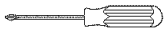
- Two adjustable wrenches 
- One rubber mallet 
- One standard screwdriver 
- One Phillips screwdriver 
- Clear tape or masking tape, and soapy water.

Assembly will be more convenient if you have a socket set, a set of open-end or closed-end wrenches, or a set of ratchet wrenches.

1. Before beginning assembly, make sure you understand the information in the box above. For help identifying small parts, use the **PART IDENTIFICATION CHART** in the center of this manual.

Attach the Front Stabilizer (3) to the Base (1) with two M10 x 78mm Carriage Bolts (50) and two M10 Nylon Locknuts (64). **Do not tighten the Locknuts yet.**

2. Attach the Rear Stabilizer (2) to the Base (1) with two M10 x 78mm Carriage Bolts (50) and two M10 Nylon Locknuts (64).

Tighten the M10 Nylon Locknuts (64) used in steps 1 and 2.

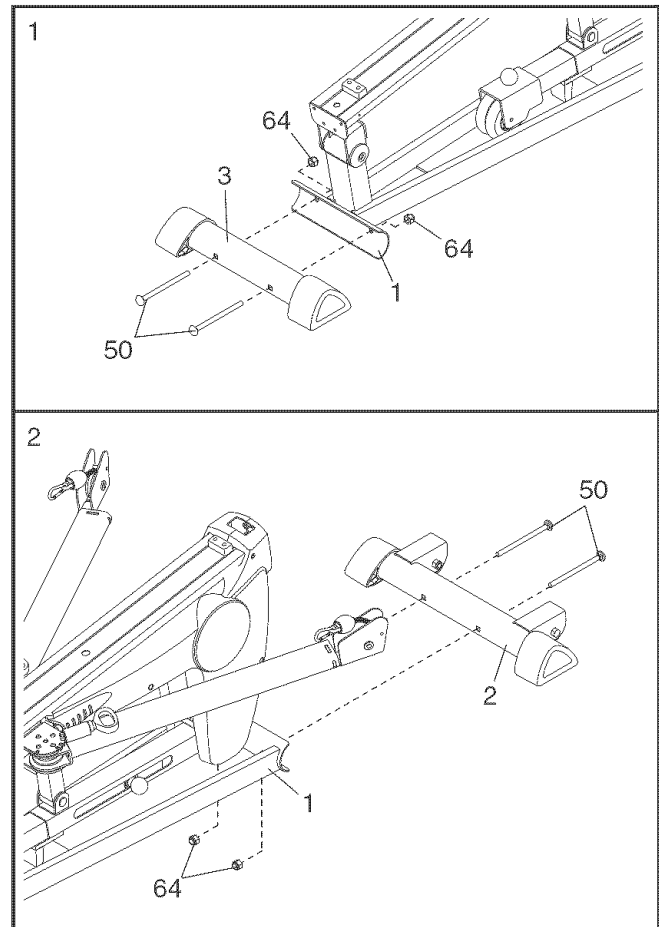

- Orient the Seat (14) as shown. Attach the Seat to the Seat Carriage (13) with four M6 x 16mm Screws (55).

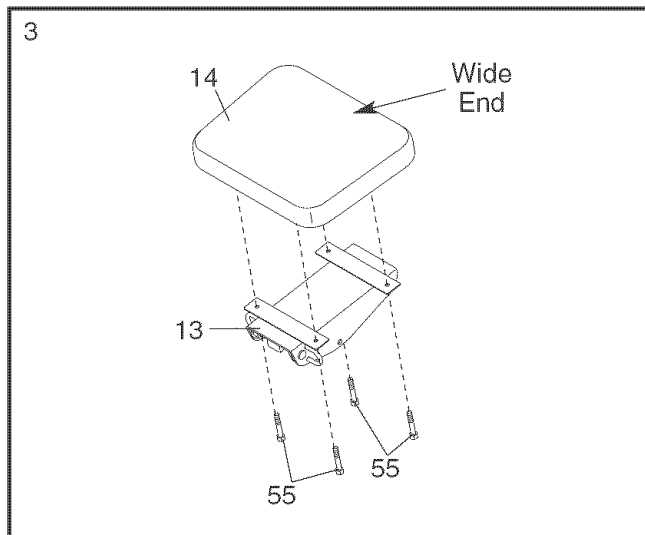

- Pull the Seat Pin (18) out of the Seat Carriage (13) and turn it 90 degrees (see inset drawing B). Set the Seat Carriage on the Rail (4) so that the Seat Pin is on the same side as the adjustment holes and the preassembled Small Seat Wheel (not shown) is under the Rail.

Insert the barrel of an M10 x 22mm Bolt Set (66) into the Small Seat Wheel (40) as shown in inset drawing A.

Have a second person press down on the Seat (14). Hold the Small Seat Wheel (40) against the bottom of the Rail (4). **Make sure that the wide side of the Wheel is held flat against the Rail (see inset drawing B).** Attach the Wheel to the Seat Carriage (13) with the M10 x 22mm Bolt Set (66). **Repeat this process with the preassembled Small Seat Wheel.**

Pull the Seat Pin (18) out and rotate it 90 degrees. Engage the Seat Pin into an adjustment hole in the Rail (4).

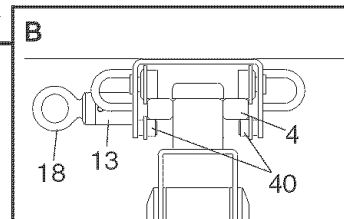
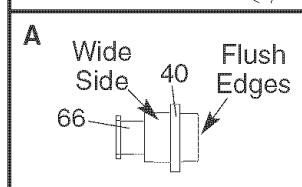
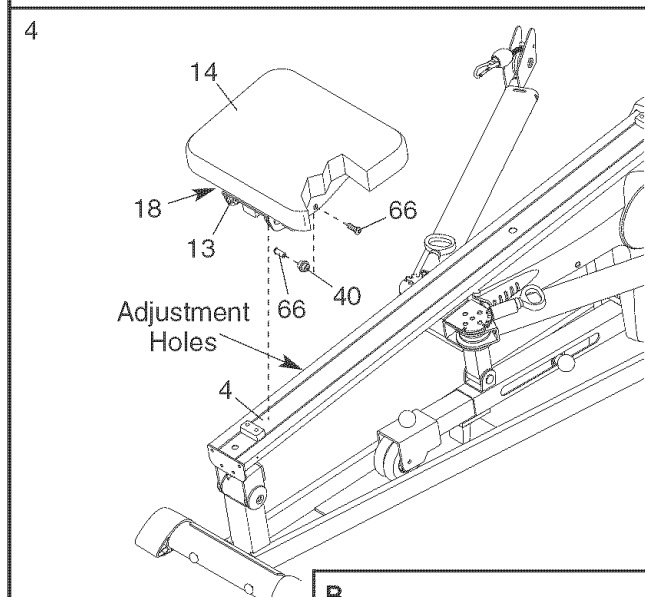

- Attach the Handlebar (10) to the end of the Rail (4), inside the Side Shields (16, 17), with four M6 x 38mm Button Screws (53). Attach the Shield Cover (43) to the Handlebar with an M4 x 25mm Round Head Screw (47).

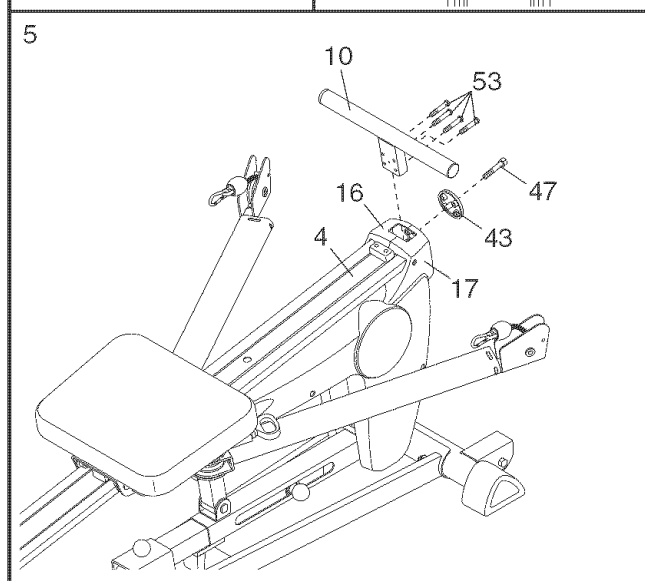

- Orient the Backrest (12) so that the narrow end is over the top of the Backrest Frame (11). Attach the Backrest to the Backrest Frame with two M6 x 25mm Screws (77) and two M6 x 45mm Screws (78).

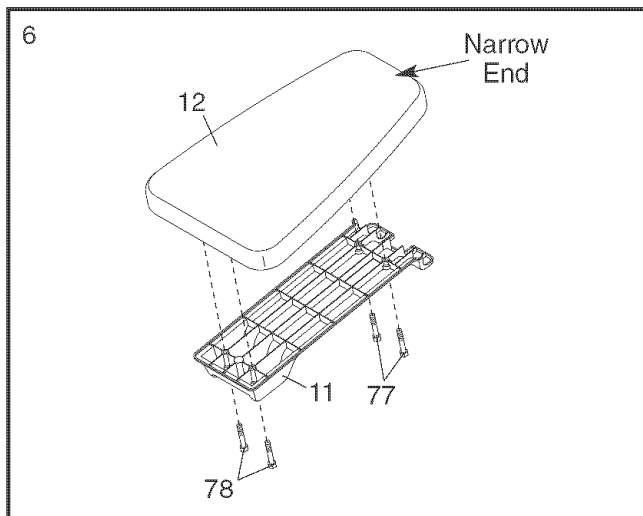

- Slide the top of the Backrest Frame (11) under the Handlebar (10). Pivot the Backrest Frame down onto the Rail (4) so that the pin on the Backrest Frame is inserted into the hole in the Rail.

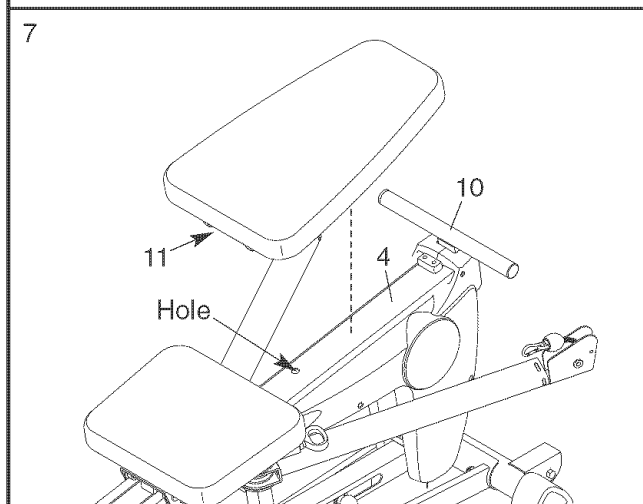

- Attach the Foot Plate (9) to the Rail (4) with four M6 x 25mm Button Screws (57). **Do not tighten the Screws yet.**

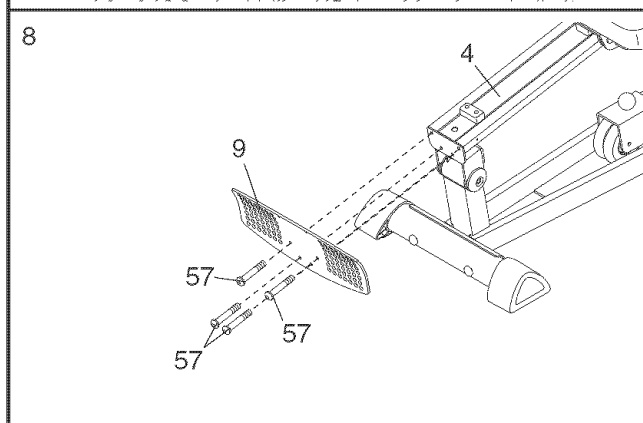

- Connect the Wire (63) to the Console (84). **The connector should slide easily into the socket and snap into place.** If it does not, turn the connector over and then insert it. **IF THE CONNECTOR IS NOT INSERTED PROPERLY, THE CONSOLE MAY BE DAMAGED WHEN THE POWER IS TURNED ON.** Push the excess Wire into the Rail (4).

Insert three "AA" batteries (not included) into the Console (84). Alkaline batteries are recommended.

Attach the Console (84) to the Rail (4) and the Foot Plate (9) with four M4 x 16mm Screws (76).

Tighten the four M6 x 25mm Screws (57) used in step 8.

- Make sure that all parts have been properly tightened. The use of the remaining parts will be explained in ADJUSTMENTS, beginning on the following page.

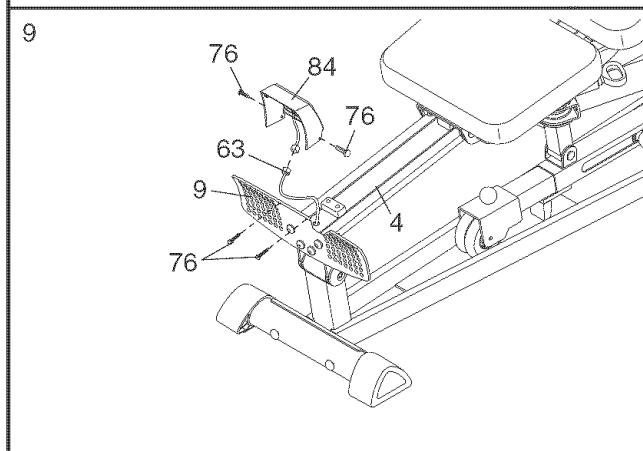

ADJUSTMENTS

This section explains how to adjust the exercise bench. See the EXERCISE GUIDELINES on page 13 for important information about how to get the most benefit from your exercise program. Refer to the accompanying exercise guide to see the correct form for each exercise.

Make sure all parts are properly tightened each time the exercise bench is used. Replace any worn parts immediately. The exercise bench can be cleaned with a damp cloth and a mild, non-abrasive detergent. Do not use solvents.

ATTACHING THE BACKREST

Slide the top of the Backrest Frame (11) under the Handlebar (10). Pivot the Backrest Frame down onto the Rail (4) so that the pin on the Backrest Frame is inserted into the hole in the Rail.

▲WARNING: Always make sure that the pin on the Backrest Frame (11) is inserted into the hole before using the Backrest (12).

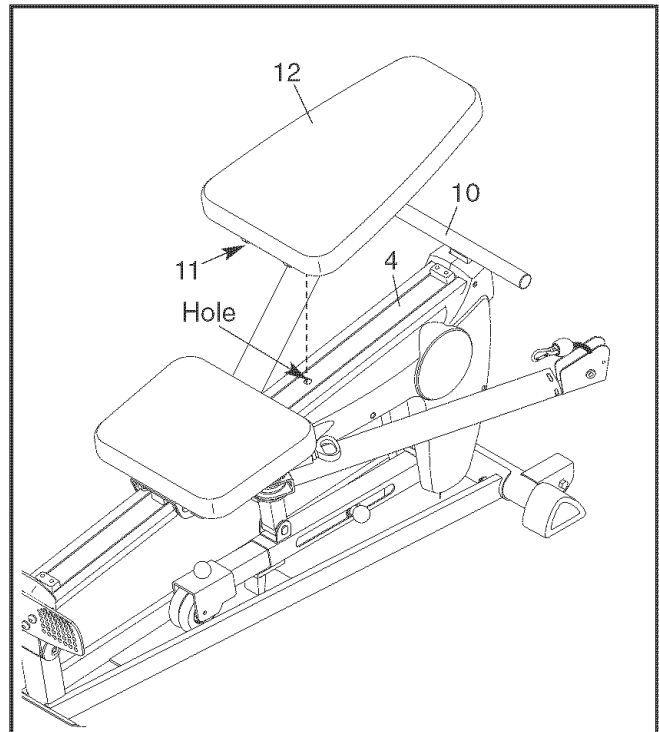

ADJUSTING THE SEAT

To adjust the Seat (14) to a different position on the Rail (4), pull the Seat Pin (18) out as far as it will go. Move the Seat to the new position and engage the Seat Pin into the Rail.

To allow the Seat (14) to roll on the Rail (4), pull the Seat Pin (18) out and turn it 90 degrees. Engage the Seat Pin into the Seat Carriage (13).

▲WARNING: Always make sure that the Seat Pin (18) is fully engaged before using the exercise bench.

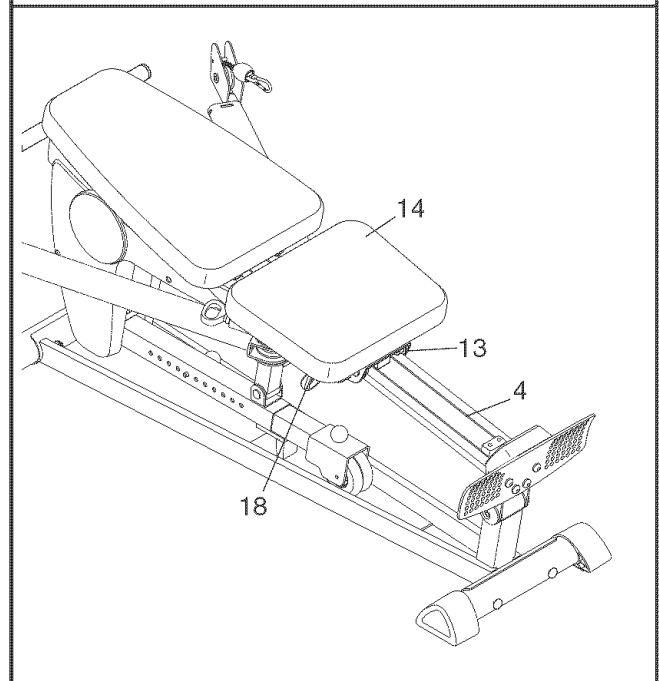

ATTACHING THE ACCESSORIES

A Handle (68) can be attached to the Rope (80) with a Clip (83). **The other accessories can be attached to the Rope in the same manner.**

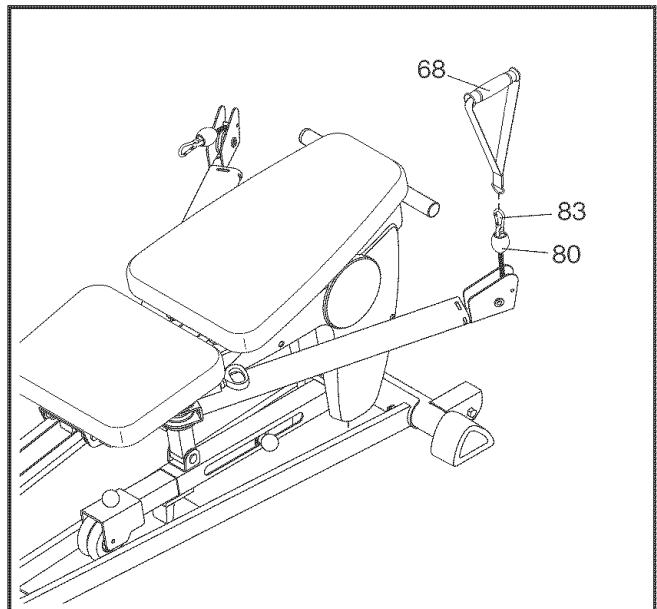

ADJUSTING THE RESISTANCE SETTING

To adjust the resistance setting, pull the Resistance Knob (27) and use the Knob (71) to slide the Resistance Leg Extension (7) into or out of the Resistance Leg (8). Engage the Resistance Knob into the Resistance Leg.

▲ WARNING: Always make sure that the Resistance Knob (27) is fully engaged into the Resistance Leg (8) before using the exercise bench.

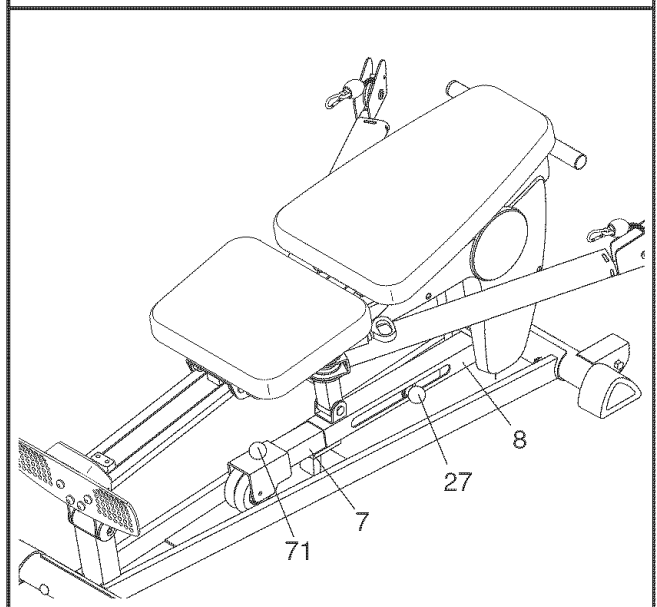

ADJUSTING THE ARM POSITION

Change the position of an Arm (5 or 6) by pulling the Arm Pin (21) until it disengages the bracket on the Rail (4). Pivot the Arm to the new position and re-engage the Arm Pin into the Rail bracket.

▲ WARNING: Always make sure that the Arm Pin (21) is fully engaged into the bracket on the Rail (4) before using the exercise bench.

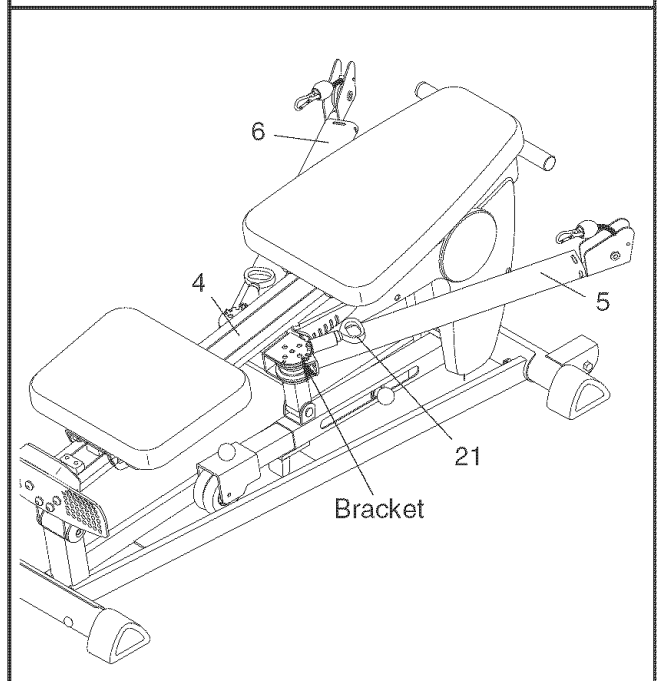

REPLACING THE BATTERIES

Remove the four M4 x 16mm Screws (76) from the Console (84). Insert three "AA" batteries in the Console battery case. Reattach the Console to the Rail (4) and the Foot Plate (9) with the four Screws.

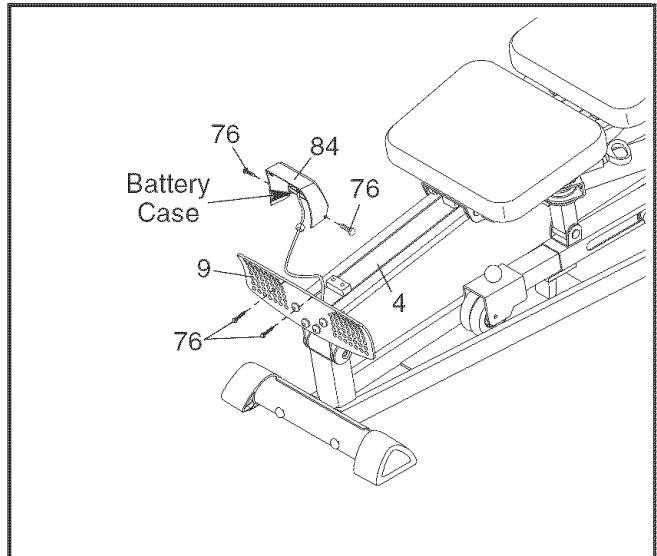

TIGHTENING THE ROPE

The type of Rope (80) used on the exercise bench can stretch slightly when it is first used. If there is slack in the Rope before resistance is felt, the Rope should be tightened.

To tighten the Rope (80), first pull one end of the Rope out until the Rope is tight. Then, measure the distance between the Rope Cover (79) and the Swivel Arm (15).

Have a second person pull the Rope (80) out and hold it while the Rope is adjusted. Push the Rope Cover (79) down the Rope and loosen the two M5 x 21mm Flat Head Screws (72). Pull the Rope through the Clip (83) and the Clamps (81, 82) to shorten the Rope by the measured amount. **Make sure that there is 1/4" between the Clamps and the Clip.** Then, retighten the two Screws and cover the Clamps with the Rope Cover.

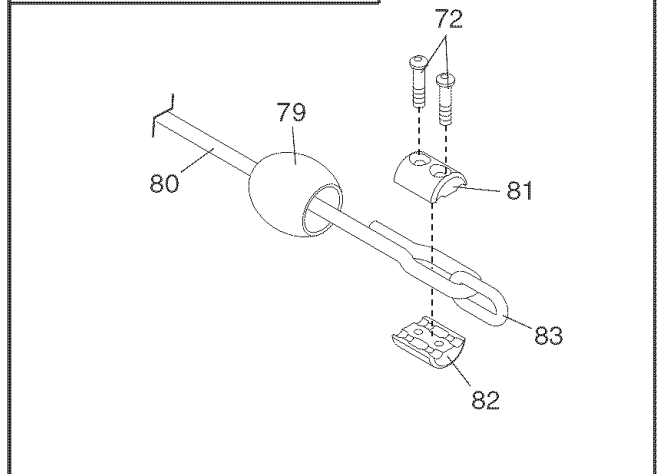
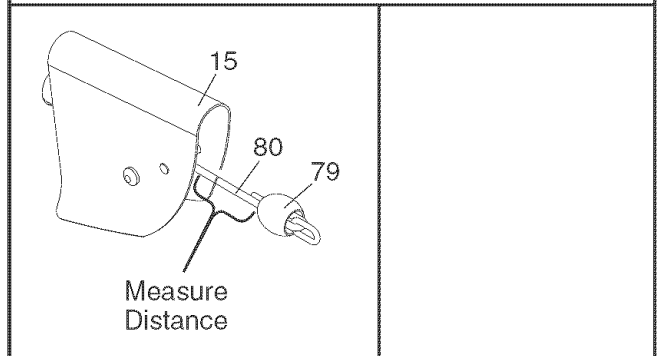

WARNING: Always make sure the two M5 x 21mm Flat Head Screws (72) are fully tightened before the exercise bench is used.

FEATURES OF THE CONSOLE

The console features five modes that provide instant exercise feedback during your workouts. The modes are described below.



Cycles/Minute—This mode displays the number of repetitions you are completing per minute.

Time—This mode displays the elapsed time. Note: If you stop exercising for a few seconds, the time mode will pause.

Total Cycles—This mode displays the total number of repetitions you have completed during your workout.

Calories—This mode displays the approximate number of calories you have burned.

Scan—This mode displays the Cycles/Minute, Time, Total Cycles, and Calories modes, for a few seconds each, in a repeating sequence.

HOW TO OPERATE THE CONSOLE

Make sure that there are batteries in the console (see **BATTERY REPLACEMENT** on page 10). If there is a sheet of clear plastic on the face of the console, remove the plastic.

Follow the steps at the right to operate the console.

1. Turn on the power.

To turn on the power, press the On/Reset button or begin exercising. The entire display will light for a moment; the console will then be ready for use.

2. Select the desired mode.

Scan mode—When the power is turned on, the Scan mode will be selected. One mode indicator will appear below the word “SCAN,” and a second mode indicator will show which mode is currently displayed. Note: If you have selected a different mode, you can reselect the Scan mode by pressing the Mode button repeatedly.

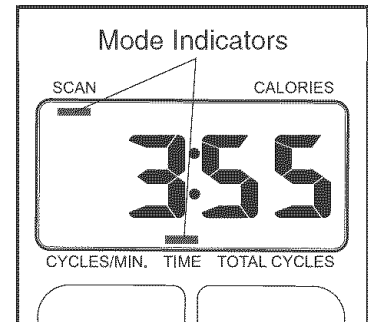

Cycles/Minute, Time, Total Cycles, or Calories mode—To select a single mode for continuous display, press the Mode button repeatedly. The mode indicators will show which mode is selected. Make sure there is not a mode indicator below the word “SCAN.”

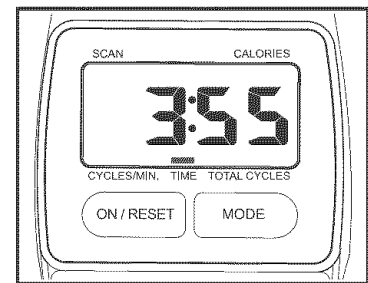

To reset the console at any time, press the On/Reset button.

3. Turn off the power.

To turn off the power, simply wait for a few minutes. The console has an “auto-off” feature. If the console buttons are not pressed and the rope is not pulled for a few minutes, the console will turn off to conserve the batteries.

WEIGHT RESISTANCE CHART

The exercise bench uses a percentage of the user's weight as resistance for exercising. The charts below show the approximate resistance in pounds for six popular exercises. **Note: The actual resistance for each exercise may vary due to differences in friction levels between the cables, pulleys, and other moving parts.**

Biceps Curl, Chest Fly, Chest Press

		RESISTANCE SETTING										
		1	2	3	4	5	6	7	8	9	10	11
USER'S WEIGHT	100	26	31	37	44	51	59	67	76	85	94	103
	110	27	32	38	46	53	61	70	79	88	98	107
	120	27	33	40	47	55	64	73	82	92	102	111
	130	28	34	41	49	57	67	76	86	96	106	116
	140	29	35	43	51	60	70	79	90	100	111	121
	150	30	36	45	54	63	73	83	94	105	116	127
	160	31	38	47	56	66	76	87	98	110	121	133
	170	32	40	49	59	69	80	91	103	115	127	139
	180	33	41	51	61	72	83	95	108	120	133	145
	190	34	43	53	64	75	87	100	113	126	139	152
	200	35	45	55	67	79	92	104	118	132	146	160
	210	36	46	58	70	83	96	110	124	138	153	167
	220	37	48	60	74	87	101	115	130	145	160	175
	230	39	50	63	77	91	106	120	136	152	168	184
	240	39	52	65	80	94	110	125	142	158	175	191
250	40	53	68	83	98	115	131	148	165	183	200	

Leg Press, Overhead Extension, Shoulder Press

		RESISTANCE SETTING										
		1	2	3	4	5	6	7	8	9	10	11
USER'S WEIGHT	100	26	30	35	40	47	55	63	71	79	88	98
	110	27	31	36	42	49	57	66	74	82	92	102
	120	27	32	38	43	51	60	69	77	86	96	106
	130	28	33	39	45	53	63	72	81	90	100	111
	140	29	34	41	47	56	66	75	85	94	105	116
	150	30	36	43	50	59	69	79	89	99	110	122
	160	31	37	45	52	62	72	83	93	104	115	128
	170	32	39	47	55	65	76	87	98	109	121	134
	180	33	40	49	57	68	79	91	103	114	127	140
	190	34	42	51	60	71	83	96	108	120	133	147
	200	35	44	53	63	75	88	100	113	126	140	155
	210	36	45	56	66	79	92	106	119	132	147	162
	220	37	47	58	70	83	97	111	125	139	154	170
	230	38	49	61	72	86	101	116	131	145	161	178
	240	39	51	63	74	89	104	120	135	151	167	185
250	40	52	66	76	91	108	124	140	157	174	192	

EXERCISE GUIDELINES

THE FOUR BASIC TYPES OF WORKOUTS

Muscle Building—To increase muscle size, use a high amount of resistance. Your muscles will adapt and grow as you progressively increase the intensity of your exercise by:

- changing the level of resistance
- changing the number of repetitions or sets performed. (A “repetition” is one complete cycle of an exercise, such as one sit-up. A “set” is a series of repetitions.)

The proper amount of resistance for each exercise depends upon the individual. You must gauge your limits and select the amount of resistance that is right for you. Begin with 3 sets of 8 repetitions for each exercise you perform. When you can complete 3 sets of 12 repetitions without difficulty, increase the amount of resistance. Rest for 3 minutes after each set.

Toning—Tone your muscles by using a moderate amount of resistance and increasing the number of repetitions in each set. Complete as many sets of 15–20 repetitions as possible without discomfort. Rest for 1 minute after each set.

Weight Loss—To lose weight, use a low amount of resistance and increase the number of repetitions in each set. Exercise for 20–30 minutes, resting for a maximum of 30 seconds between sets.

Cross Training—Cross training is an efficient way to get a complete and well-balanced fitness program. An example of a balanced program is:

- Strength training workouts on Monday, Wednesday, and Friday.
- 20–30 minutes of aerobic exercise, such as riding an exercise bike or running on a treadmill, on Tuesday and Thursday.
- Rest from both strength training and aerobic exercise for at least one full day each week to give your body time to regenerate.

PERSONALIZING YOUR EXERCISE PROGRAM

Determining the right length of time for each workout, as well as the number of repetitions and sets completed, is an individual matter. It is important to avoid overdoing it during the first few months of your exercise program. You should progress at your own pace and be sensitive to your body’s signals. If you experience pain or dizziness at any time while exercising, stop immediately and begin cooling down. Find out what is wrong before continuing. Remember that adequate rest and a proper diet are important factors in any exercise program.

Warming Up—Begin each workout with 5–10 minutes of stretching and light exercise to warm up. Warming up prepares your body for more strenuous exercise by raising your body temperature, increasing circulation, and delivering more oxygen to your muscles.

Working Out—Each workout should include 6–10 different exercises. Select exercises for every major muscle group, emphasizing areas that you want to develop most. To give balance and variety to your workouts, vary the exercises from session to session.

Schedule your workouts for the time of day when your energy level is the highest. Each workout should be followed by at least one day of rest. Once you find the right schedule for you, stick with it.

Exercise Form—Maintaining proper form is an essential part of an effective exercise program. This requires moving through the full range of motion for each exercise, and moving only the appropriate parts of the body. Exercising in an uncontrolled manner will leave you feeling exhausted. The exercise guide shows the correct form for several exercises and describes how to perform the exercise.

The repetitions in each set should be performed smoothly and without pausing. A repetition’s exertion stage should last about half as long as the return stroke. Proper breathing is important. Exhale during the exertion stage of each repetition and inhale during the return stroke. Never hold your breath. Rest for a short period of time after each set. The time depends on which type of workout you are performing (see THE FOUR BASIC TYPES OF WORKOUTS).

Plan to spend the first couple of weeks familiarizing yourself with the equipment and learning the proper form for each exercise.

Cooling Down—End each workout with 5–10 minutes of stretching. Include stretches for both your arms and legs. Move slowly as you stretch and do not bounce. Ease into each stretch gradually and go only as far as you can without strain. Stretching at the end of each workout is an effective way to increase flexibility.

Staying Motivated—For motivation, keep a record of each workout. The charts on pages 14 and 15 can be photocopied and used to record your workouts. List the date, the exercises performed, the resistance used, and the numbers of sets and repetitions completed. Record your weight and key body measurements at the end of every month. Remember, the key to achieving the greatest results is to make exercise a regular and enjoyable part of your everyday life.

MONDAY Date: _____ / /	EXERCISE	WEIGHT	SETS	REPS

TUESDAY **AEROBIC EXERCISE**
 Date: _____
 / /

WEDNESDAY Date: _____ / /	EXERCISE	WEIGHT	SETS	REPS

THURSDAY **AEROBIC EXERCISE**
 Date: _____
 / /

FRIDAY Date: _____ / /	EXERCISE	WEIGHT	SETS	REPS

Make photocopies of this page for scheduling and recording your workouts.

MONDAY Date: _____ / /	EXERCISE	WEIGHT	SETS	REPS

TUESDAY **AEROBIC EXERCISE**
 Date: _____
 / /

WEDNESDAY Date: _____ / /	EXERCISE	WEIGHT	SETS	REPS

THURSDAY **AEROBIC EXERCISE**
 Date: _____
 / /

FRIDAY Date: _____ / /	EXERCISE	WEIGHT	SETS	REPS

Make photocopies of this page for scheduling and recording your workouts.

PART IDENTIFICATION CHART

Refer to the drawings below to identify small parts used in assembly. The number in parentheses by each drawing is the key number of the part, from the PART LIST in the center of this manual. **Note: Some small parts may have been pre-attached. If a part is not in the parts bag, check to see if it has been pre-attached.**



M10 x 78mm Carriage Bolt (50)

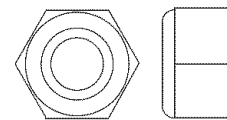

M10 Nylon Locknut (64)



M6 x 45mm Screw (78)

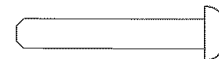

M4 x 25mm Round Head Screw (47)

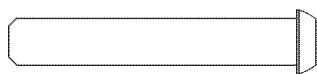

M6 x 38mm Button Screw (53)

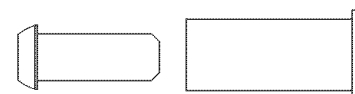

M10 x 22mm Bolt Set (66)

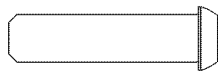

M6 x 25mm Button Screw (57)

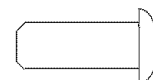

M6 x 16mm Screw (55)

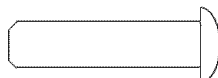

M6 x 25mm Screw (77)

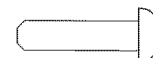

M4 x 16mm Screw (76)

PART LIST—Model No. PFCG2224.0

R0205C

Key No.	Qty.	Description	Key No.	Qty.	Description
1	1	Base	46	4	M4 x 38mm Round Head Screw
2	1	Rear Stabilizer	47	5	M4 x 25mm Round Head Screw
3	1	Front Stabilizer	48	1	M8 x 46mm Button Screw
4	1	Rail	49	4	M6 x 8mm Bolt
5	1	Left Arm	50	4	M10 x 78mm Carriage Bolt
6	1	Right Arm	51	2	M10 x 60mm Button Bolt
7	1	Resistance Leg Extension	52	1	M8 x 63mm Bolt Set
8	1	Resistance Leg	53	4	M6 x 38mm Button Screw
9	1	Foot Plate	54	2	3/8" x 63mm Button Bolt
10	1	Handlebar	55	4	M6 x 16mm Screw
11	1	Backrest Frame	56	1	3/8" x 150mm Bolt
12	1	Backrest	57	4	M6 x 25mm Button Screw
13	1	Seat Carriage	58	2	M8 x 22mm Button Bolt
14	1	Seat	59	2	3/8" x 48mm Button Bolt
15	2	Swivel Arm	60	1	3/8" x 120mm Bolt
16	1	Right Side Shield	61	1	M13 x 60mm Bolt Set
17	1	Left Side Shield	62	1	Hip Strap
18	1	Seat Pin	63	1	Wire
19	4	Stabilizer Endcap	64	6	M10 Nylon Locknut
20	2	Wheel	65	1	M10 x 16mm Button Bolt
21	2	Arm Pin	66	2	M10 x 22mm Bolt Set
22	2	Plastic Spacer	67	1	1/2" Nylon Locknut
23	2	Small Plastic Spacer	68	2	Handle
24	4	Arm Bushing	69	2	Snap Ring
25	1	Ankle Strap	70	5	M8 Washer
26	2	Stabilizer Wheel	71	1	Knob
27	1	Resistance Knob	72	6	M5 x 21mm Flat Head Screw
28	1	Bumper	73	2	Arm Endcap
29	2	Stop Pad	74	2	4mm Spacer
30	2	Rail Cover	75	6	3/8" Nylon Locknut
31	2	Arm Sleeve	76	8	M4 x 16mm Screw
32	2	1 3/4" Pulley	77	2	M6 x 25mm Screw
33	9	2" Pulley	78	2	M6 x 45mm Screw
34	2	Base Bushing	79	2	Rope Cover
35	2	Rail Bushing	80	1	Rope
36	1	Reed Switch	81	2	Upper Clamp
37	2	2 1/8" Pulley	82	2	Lower Clamp
38	4	Swivel Arm Bushing	83	2	Clip
39	2	Lower Rail Bushing	84	1	Console
40	2	Small Seat Wheel	85	1	Magnet
41	4	Seat Wheel	86	2	M8 Large Washer
42	2	Handlebar Endcap	87	2	6mm Spacer
43	1	Shield Cover	#	1	User's Manual
44	1	Axle	#	1	Exercise Guide
45	9	M10 Washer			

Note: “#” indicates a non-illustrated part. Specifications are subject to change without notice. See the back cover of this manual for information about ordering replacement parts.

ORDERING REPLACEMENT PARTS

To order replacement parts, see the front cover of this manual. To help us assist you, please be prepared to give the following information:

1. The MODEL NUMBER of the product (PFCG2224.0)
2. The NAME of the product (PROFORM CARDIO GLIDE PLUS exercise bench)
3. The SERIAL NUMBER of the product (see the front cover of this manual)
4. The KEY NUMBER and DESCRIPTION of the part(s) (see the PART LIST and EXPLODED DRAWING at the center of this manual)

LIMITED WARRANTY

ICON Health & Fitness, Inc. (ICON), warrants this product to be free from defects in workmanship and material, under normal use and service conditions, for a period of ninety (90) days from the date of purchase. This warranty extends only to the original purchaser. ICON's obligation under this warranty is limited to replacing or repairing, at ICON's option, the product through one of its authorized service centers. All repairs for which warranty claims are made must be pre-authorized by ICON. If the product is shipped to a service center, freight charges to and from the service center will be the customer's responsibility. For in-home service, the customer will be responsible for a minimal trip charge. This warranty does not extend to any product or damage to a product caused by or attributable to freight damage, abuse, misuse, improper or abnormal usage or repairs not provided by an ICON authorized service center; products used for commercial or rental purposes; or products used as store display models. No other warranty beyond that specifically set forth above is authorized by ICON.

ICON is not responsible or liable for indirect, special or consequential damages arising out of or in connection with the use or performance of the product or damages with respect to any economic loss, loss of property, loss of revenues or profits, loss of enjoyment or use, costs of removal or installation or other consequential damages of whatsoever nature. Some states do not allow the exclusion or limitation of incidental or consequential damages. Accordingly, the above limitation may not apply to you.

The warranty extended hereunder is in lieu of any and all other warranties and any implied warranties of merchantability or fitness for a particular purpose is limited in its scope and duration to the terms set forth herein. Some states do not allow limitations on how long an implied warranty lasts. Accordingly, the above limitation may not apply to you.

This warranty gives you specific legal rights. You may also have other rights which vary from state to state.

ICON HEALTH & FITNESS, INC., 1500 S. 1000 W., LOGAN, UT 84321-9813