



Electric Warming Drawer

Safety Instructions 2, 3

Operating Instructions

Control Knob5
Crisping Stale Items7
Drawer6
Features4
Moisture Selector5
ON Signal Light5
Pans5
Proofing Yeast Bread
and Dough7
Rack6
Temperature Selection Charts ...7, 8
Warming Serving Bowl
and Plates6

Care and Cleaning 9

Installation Instructions 10–15

Troubleshooting Tips 16

Consumer Support

Consumer Support Back Cover
Product Registration 19, 20
Warranty for Customers
in Canada23
Warranty for Customers
in the U.S.A.22

Write the model and serial numbers here:

Model # _____

Serial # _____

You can find them on a label located on the backside of the lower drawer front.

In Canada, contact us at:
www.GEAppliances.ca

**Owner's Manual and
Installation Instructions**

JKD915
JTD915



IMPORTANT SAFETY INFORMATION. READ ALL INSTRUCTIONS BEFORE USING.

⚠ WARNING!

For your safety, the information in this manual must be followed to minimize the risk of fire or explosion, electric shock, or to prevent property damage, personal injury, or loss of life.



⚠ WARNING ANTI-TIP BRACE REQUIRED

All warming drawers can tip and injury could result if not properly installed.

To prevent accidental tipping of the warming drawer, attach it to the wall with an anti-tip brace as described in the Installation Instructions.

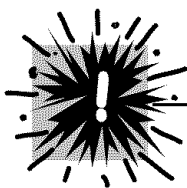

SAFETY PRECAUTIONS

When using electrical appliances, basic safety precautions should be followed, including the following:

- Use this appliance only for its intended purpose as described in this Owner's Manual.
- Be sure your appliance is properly installed and grounded by a qualified technician in accordance with the provided installation instructions.
- Do not attempt to repair or replace any part of your warming drawer unless it is specifically recommended in this manual. All other servicing should be referred to a qualified technician.
- Have the installer show you the location of the circuit breaker or fuse. Mark it for easy reference.
- Before performing any service, unplug or disconnect the power supply at the household distribution panel by removing the fuse or switching off the circuit breaker.
- Do not leave children alone—children should not be left alone or unattended in an area where an appliance is in use. They should never be allowed to sit or stand on any part of the appliance.
- Do not allow anyone to climb, stand or hang on the drawer. They could damage the warming drawer, or cause severe personal injury.
- Be sure the warming drawer is securely installed in a cabinet that is firmly attached to the house structure.
- Never leave the drawer open when you are not watching the warming drawer.
- Always keep combustible wall covering, curtains or drapes a safe distance from your warming drawer.
- Always keep wooden and plastic utensils and canned food a safe distance away from your warming drawer.
- Teach children not to play with the controls or any other part of the warming drawer.
- Do not place more than 50 pounds into the drawer.
- For your safety, never use your appliance for warming or heating the room.

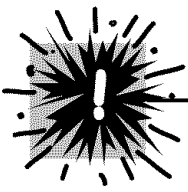

⚠ WARNING! SAFETY PRECAUTIONS

The purpose of the warming drawer is to hold hot cooked foods at serving temperature. Always start with hot food; cold food cannot be heated or cooked in the warming drawer.

- Do not warm food in the warming drawer for more than two hours.
- **⚠ CAUTION:** Items of interest to children should not be stored in cabinets above the warming drawer; children climbing on the drawer to reach items could be seriously injured.
- Use only dry pot holders—moist or damp pot holders on hot surfaces may result in burns from steam. Do not let pot holders touch hot heating elements. Do not use a towel or other bulky cloth.
- Do not let cooking grease or other flammable materials accumulate in or near the warming drawer.
- Do not use water on grease fires. Never pick up a flaming pan. Turn the controls off.

Flame in the warming drawer can be smothered by closing the drawer or using a multi-purpose dry chemical or foam-type fire extinguisher.
- Do not touch the heating element or the interior surface of the warming drawer. These surfaces may be hot enough to burn.

REMEMBER: The inside surface of the warming drawer may be hot when the drawer is opened.
- Do not store or use combustible materials, gasoline or other flammable vapors and liquids in the vicinity of this or any other appliance.
- Never leave jars or cans of fat drippings in or near your warming drawer.
- Use care when opening the drawer. Open the drawer a crack and let hot air or steam escape before removing or replacing food. Hot air or steam which escapes can cause burns to hands, face and/or eyes.
- Do not heat unopened food containers. Pressure could build up and the container could burst, causing an injury.
- Keep the vent unobstructed.
- Do not use the warming drawer to dry newspapers. If overheated, they can catch on fire.
- Do not use the warming drawer for a storage area. Items stored in the warming drawer can ignite.
- Do not leave paper products, cooking utensils or food in the warming drawer when not in use.
- Clean only parts listed in the *Care and cleaning of the warming drawer* section.
- Do not use aluminum foil to line the drawer. Foil is an excellent heat insulator and will trap heat beneath it. This will upset the performance of the drawer and it could damage the interior finish.
- Wear proper apparel. Loose fitting or hanging garments should never be worn while using this appliance.



READ AND FOLLOW THIS SAFETY INFORMATION CAREFULLY.
SAVE THESE INSTRUCTIONS

Features of your warming drawer.

Not all features are on all models. Appearance may vary.

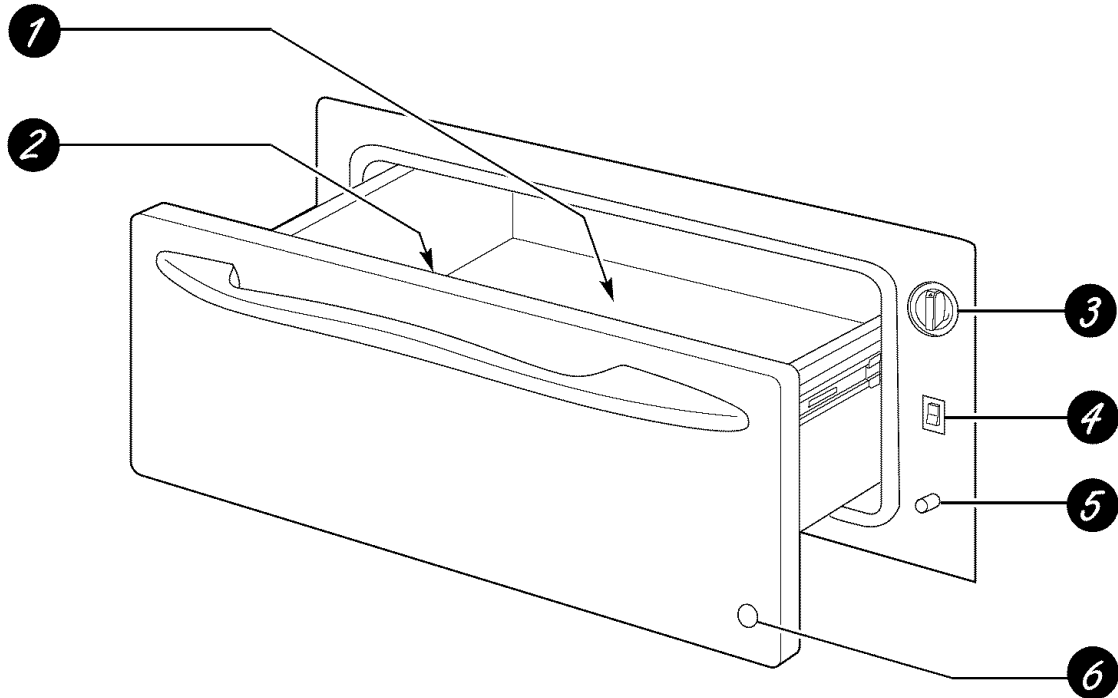

Feature Index

Page

1	Warming Drawer	10
2	Moisture Selector (on back of panel) Use this to keep foods moist or crisp.	6, 8, 9
3	Control Knob The control knob has settings for PROOF, LOW, MED and HIGH .	6, 8, 9
4	ON/OFF Switch Use this switch to turn the warming drawer on.	6
5	ON Signal Light Glows when the ON/OFF switch is in the ON position.	6
6	ON Signal Light Viewer Lens The ON signal light is visible through the light viewer lens when the drawer is closed.	6

Using the warming drawer.

The warming drawer will keep hot, cooked foods at serving temperature. Always start with hot food. Do not use to heat cold food other than proofing yeast dough, crisping crackers, chips or dry cereal.

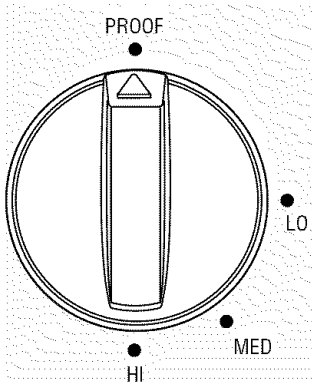

Control Knob

The warming drawer controls are hidden with the drawer shut. Open the drawer. The controls are on the right side of the front frame.

To use the warming drawer, press the **ON/OFF** switch to the **ON** position.

Slide the moisture selector control to the open or closed setting. (See the *Moisture Selector* section.)

Turn the control knob to the desired setting.

PROOF	75–95°F
LOW	140–160°F
MED	160–195°F
HIGH	195–230°F

ON Signal Light

The **ON** signal light is located below the **ON/OFF** switch and glows when the **ON/OFF** switch is in the **ON** position. It stays on until the **ON/OFF** switch is moved to the **OFF** position.

The **ON** signal light is visible through the light viewer in the drawer front panel when the drawer is closed. This is a reminder that the heat is on.

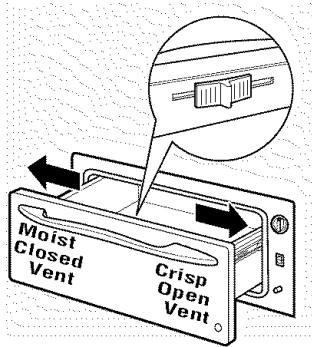

Moisture Selector

The moisture selector is located on the inside front of the drawer.

To keep foods moist, slide the moisture selector control away from the control knob. This closes the vent and seals the moisture inside the drawer. With the vent closed hot foods stay moist and soft.

In this setting condensation may occur around the inside edge of the drawer.

To keep foods crisp, slide the moisture selector control to the right towards the control knob. This opens the vents and allows the moisture to escape.

With the vents open, it is normal for moisture to collect on surfaces above the warming drawer.

Additional Pans

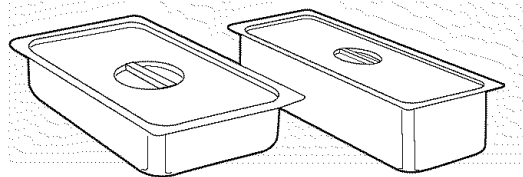

An accessory pan kit **JXPN2** is available from GE at extra cost.

Two pans with lids (4" deep)

- One large pan (14 quarts)
- One medium pan (6 quarts)

Using the warming drawer.

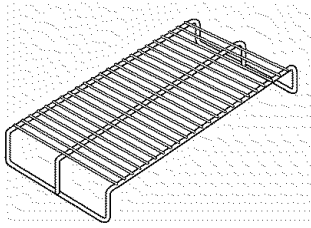

Rack

- Rack will fit from front to back.
- Preheat with the rack in place.
- Using the rack allows for double stacking of items.

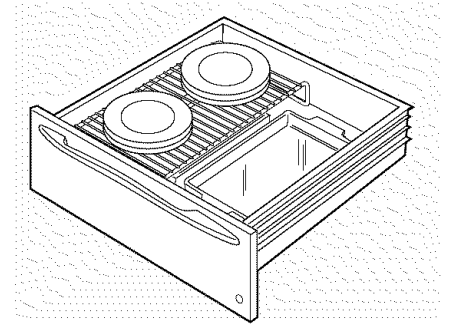

Double stacking items with the rack in position.

When using the warming drawer...

Do not line the warming drawer with aluminum foil.

- Allow time for the drawer to be preheated:

LOW 8 minutes

MED 15 minutes

HIGH 20 minutes

NOTE: It is not necessary to preheat the drawer for proofing.

Food in heat-safe glass and glass ceramic pans may need higher thermostat setting as compared to food in metal pans.

- Repeated opening of the drawer allows the hot air to escape and the food to cool. Allow extra time for temperature inside the drawer to stabilize after adding items.

- With large loads it may be necessary to use a higher thermostat setting and cover some of the cooked food items.

- Food should be kept hot in its cooking container or transferred to a heat-safe serving dish.

- Aluminum foil may be used to cover food to prevent it from drying out.

⚠ CAUTION: Plastic containers or plastic wrap will melt if in direct contact with the drawer. Melted plastic may not be removable and is not covered under your warranty.

- Remove serving spoons, etc., before placing containers in warming drawer.

To Warm Serving Bowl and Plates

To warm serving bowls and plates set the control on LOW.

- Use only heat-safe dishes.
- Place the empty dishes on the rack to raise them off the bottom of the drawer. If you want hotter dishes or want to heat fine china, please check with the manufacturer of the dishes for their maximum heat tolerance.
- Preheat empty serving dish while preheating the drawer.

- When holding hot, cooked foods and warming empty serving dishes at the same time, place the serving dishes on the high rack position and the food on the bottom of the drawer.

⚠ CAUTION: Dishes may be hot. Use pot holders or mitts when removing hot dishes.

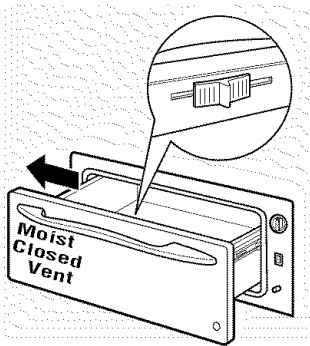

To Proof Yeast Bread Dough

Yeast dough can be proofed in the warming drawer.

- Place your dish on the warming drawer bottom.
- You must always turn the control knob to **LOW** then immediately back to **PROOF**.
- Close the vent.
- Lightly oil the top of the dough in a bowl large enough to double the dough size. Cover with a cloth.
- Preheating not required for proofing.
- Check the dough height in 40 minutes. Add time as needed. The dough should remain in the drawer until it has doubled in size and a slight depression remains when the surface is touched gently with a finger.

To Crisp Stale Items

- Place food in low sided dishes or pans.
- Preheat on **LOW** setting and open the vent.
- Check crispness after 45 minutes. Add time as needed.

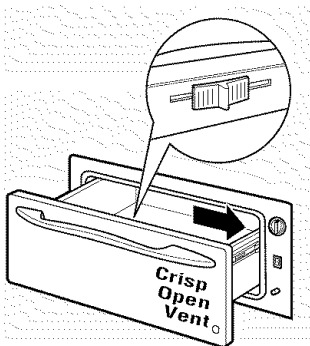

Temperature Selection Chart for Crisp Foods

To keep several different foods hot, set the temperature to the food needing the highest setting. Place the items needing the highest setting on the bottom of the drawer and items needing less heat on the rack.

Food Type	Control Setting	Moisture Selector Setting
Bacon	HIGH	OPEN
Bread, hard rolls	MED	OPEN
Fried foods	HIGH	OPEN
Pies, two crusts	MED	OPEN
Pizza	HIGH	OPEN
Potatoes, baked	HIGH	OPEN
Tortilla Chips	LOW	OPEN

Tips:

- Leave food uncovered.
- Do not use plastic containers or plastic wrap.
- Preheat prior to use according to recommended times.

Using the warming drawer.

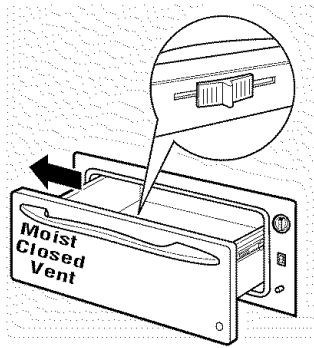

Temperature Selection Chart for Moist Foods

To keep several different foods hot, set the temperature to the food needing the highest setting. Place the items needing the highest setting on the bottom of the drawer and items needing less heat on the rack.

Food Type	Control Setting	Moisture Selector Setting
Beef, medium and well done*	MED	CLOSED
Bread, soft rolls	MED	CLOSED
Casseroles	MED	CLOSED
Cooked cereal	MED	CLOSED
Eggs	MED	CLOSED
Fish, seafood	MED	CLOSED
Fruit	MED	CLOSED
Gravy, cream sauces	MED	CLOSED
Ham	MED	CLOSED
Lamb	MED	CLOSED
Pancakes, waffles	HIGH	CLOSED
Pies, one crust	MED	CLOSED
Pork	MED	CLOSED
Potatoes, mashed	MED	CLOSED
Poultry	HIGH	CLOSED
Vegetables	MED	CLOSED

* USDA/FSIS recommends an internal temperature of 145°F. as the minimum doneness for beef. Use a portable meat thermometer to check internal temperatures.

Tips:

- Cover food with lid or aluminum foil.
- Do not put water in the warming drawer.
- Do not use plastic containers or plastic wrap.
- Preheat prior to use according to recommended times.

Care and cleaning of the warming drawer.

www.GEAppliances.com

Be sure the controls are in the OFF position and all surfaces are cool before cleaning any part of the warming drawer.

Warming Drawer

Use soap and warm water to thoroughly clean.

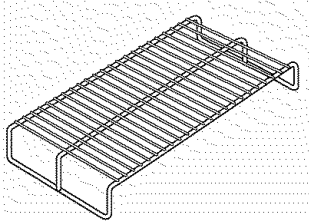

Rack

Clean the rack with detergent and water. After cleaning, rinse the rack with clean water and dry with a clean cloth.

Stainless Steel

Do not use a steel wool pad; it will scratch the surface.

To clean the stainless steel surface, use warm sudsy water or a stainless steel cleaner or polish. Always wipe the surface in the direction of the grain. Follow cleaner instructions for cleaning the stainless steel surface.

To inquire about purchasing stainless steel appliances cleaner or polish, or to find the location of a dealer nearest you, please call our toll-free number:

National Parts Center **1.877.959.8688**

www.GEAppliances.com

Control Knob

The control knob may be removed for easier cleaning.

Before removing the knob for cleaning, please note that it is in the **PROOF** position.

Wash the knob in soap and water or a vinegar and hot water solution but do not soak.

Dry and replace the knob.

Safety Instructions

Operating Instructions

Care and Cleaning

Installation Instructions

Troubleshooting Tips

Consumer Support

Installation of the warming drawer.

Read these instructions completely and carefully.



Before You Begin

IMPORTANT: Save these instructions for the local electrical inspector's use.

IMPORTANT: OBSERVE ALL GOVERNING CODES AND ORDINANCES.

NOTE TO INSTALLER: Leave these instructions with the appliance after installation is completed.

NOTE TO CONSUMER: Keep this Owner's Manual and Installation Instructions for future use.

NOTE: This appliance must be properly grounded.

NOTE: Insure that the power cord does not contact the hot surfaces on the bottom of ovens, cooktops, or any other appliance.

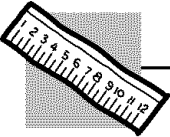

Product Dimensions

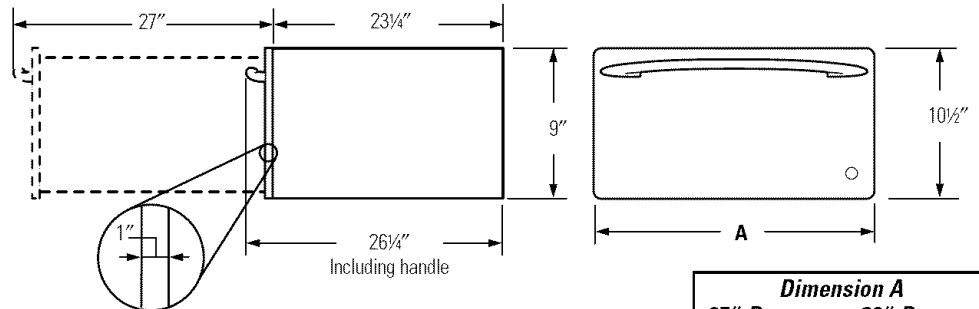

Dimension A	
27" Drawer	30" Drawer
26 3/4"	30"



Custom Panel Kits

ZXD27B—This kit provides for the installation of a custom front panel on 27" wide models.

ZXD30B—This kit provides for the installation of a custom front panel on 30" wide models.

Tools Needed



- 2 x 4 or 2 x 2 lumber for runners and brace
- Wood screws and adhesive or other hardware for installing runners or shelf to support warmer drawer.
- Runners must be level, rigidly mounted and capable of supporting 150 pounds.
- Saw
- Level
- Drill and 1/16" bit
- Phillips screwdriver

Read these instructions completely and carefully.



Advance Planning

- The warming drawer may be installed directly into a wall or wall oven cabinetry.
- The warming drawer may be installed below a countertop, a single or double oven and side by side using 2 drawers.
- When installing warming drawer with a cooktop allow a 2" minimum from bottom of a cooktop burner box to top of cutout.
- Electrical power cord is located on the right side of the warming drawer. Locate the outlet within reach of the 56" long power cord in adjacent cabinet, within 42" of the right side or 16" from the left side of the cutout. A recessed receptacle can be installed on the right side of the cutout, 7" maximum from the back of the cabinet.

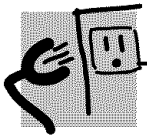

Grounding the Appliance

IMPORTANT—(Please read carefully)

FOR PERSONAL SAFETY, THIS APPLIANCE MUST BE PROPERLY GROUNDED.

Do not use an extension cord or adapter plug with this appliance. Follow National Electrical codes and ordinances.

This warming drawer must be supplied with 120V, 60Hz, and connected to an individual, properly grounded branch circuit, and protected by a 15 or 20 amp circuit breaker or time delay fuse.

- A properly grounded 3-prong receptacle should be located within reach of the drawer's 56" long power cord.
- Locate the receptacle in an adjacent cabinet.
 - within 42" of the right side or;
 - within 16" of the left side or
 - A recessed receptacle may be located on the right side of the cutout, 7" maximum from the back of the cabinet. In this location, the excess power cord should be coiled and taped to the right side of the unit.

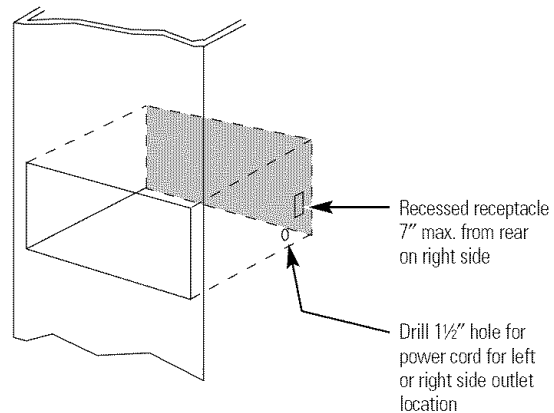

IMPORTANT—(Please read carefully)

The power cord of this appliance is equipped with a 3-prong (grounding) plug that mates with a standard 3-prong grounding wall receptacle to minimize the possibility of electric shock. The customer should have the wall receptacle and circuit checked by a qualified electrician to make sure the receptacle is properly grounded and has the correct polarity.

- Where a standard 2-prong wall receptacle is encountered, it is the personal responsibility and obligation of the customer to have it replaced with a properly grounded 3-prong wall receptacle.

Do not, under any circumstances, cut or remove the third (ground) prong from the power cord.

DO NOT USE AN EXTENSION CORD.

Installation of the warming drawer.

Read these instructions completely and carefully.



Remove Packaging and Parts

Parts provided: 4 Wood screws

- 1 Place carton on a flat surface.
- 2 Open one end of the carton and lift off the top piece.
- 3 Lift the warming drawer up and out of the carton.
- 4 Place the drawer on top of the shipping carton to protect the drawer front and the finished flooring.
- 5 Remove all packing materials and tape.
- 6 Locate package containing 4 wood screws and set aside.

Installation Below a Countertop

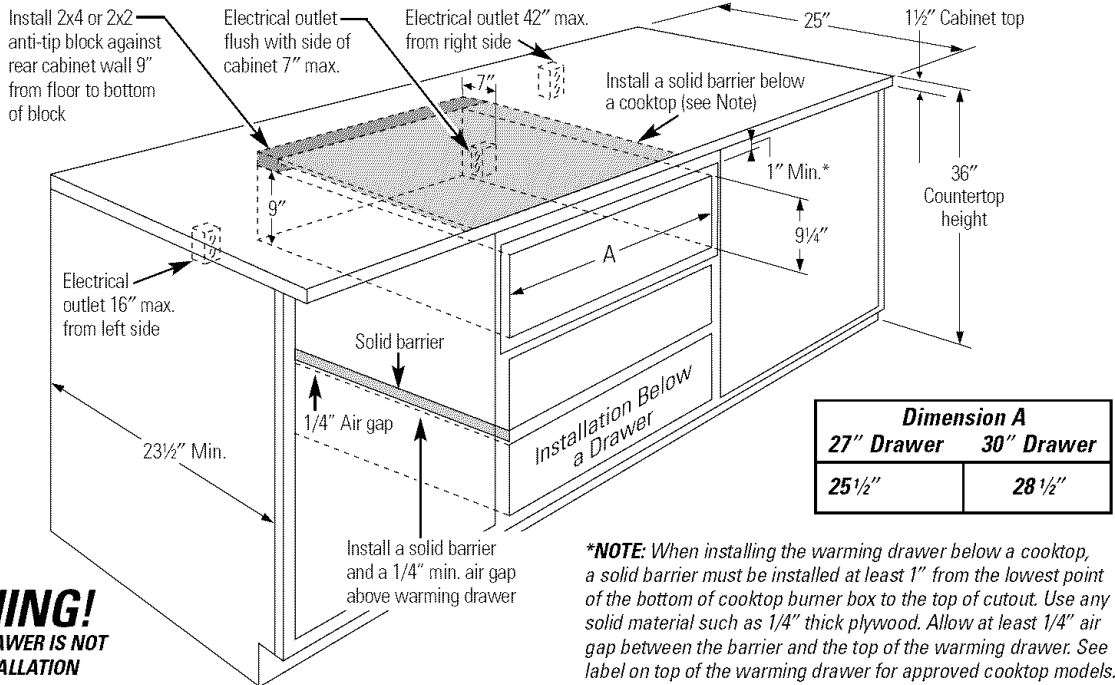
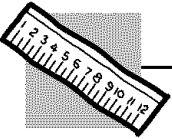

▲ WARNING!
IN CANADA THIS DRAWER IS NOT APPROVED FOR INSTALLATION UNDER A COOKTOP.

- When installed, the front face of the warming drawer will be nearly flush with cabinetry doors or drawer fronts.
- Drawer overlaps will conceal cut edges on all sides of the opening.

The rough opening for the drawer must be:

- Depth:** 23 1/2" minimum from inside back to front of cabinet frame.
- Width:** 25 1/2" for 27" wide models
28 1/2" for 30" wide models.
- Height:** 9 1/4"
- 5" minimum above floor or 1" above toekick. 23 1/4" from floor to bottom of cutout is recommended for under countertop installation.

Installation below a cabinet drawer:

The warming drawer may be installed beneath a cabinet drawer. In this installation, a solid barrier should be installed above the warming drawer to block access. Use any solid material such as 1/4" thick plywood. Allow at least 1/4" air gap between the barrier and the top of the warming drawer. Observe the 5" min. above the floor or 1" above the toekick min. installation height.

NOTE: If you are installing in frameless cabinets, it may be necessary to install 1/2" wide cleats to accept drawer mounting screws. See drawer to find exact locations of mounting screws.

When installed under a cooktop:

Warming drawers are suitable for installation below only certain specified cooktop models. See the label attached to the top of the warming drawer for suitable models. A solid barrier and air gap between cooktop and warming drawer is required. See Note above.

Read these instructions completely and carefully.

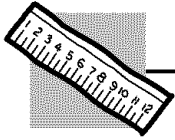

Installation Below Wall Ovens

Installation below a single oven

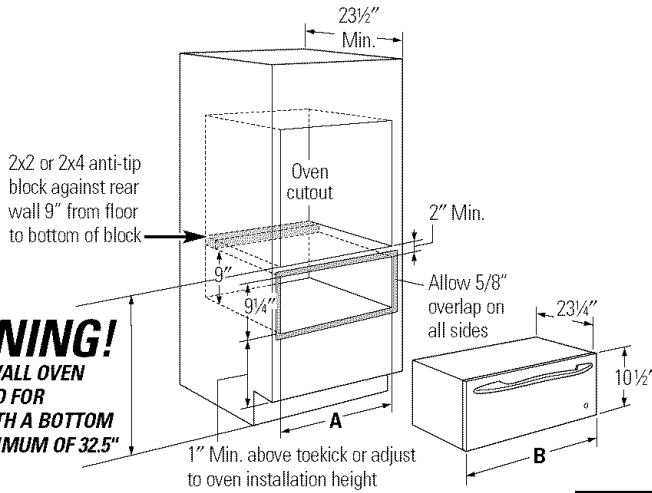

⚠ WARNING!
IN CANADA THE WALL OVEN IS ONLY APPROVED FOR INSTALLATION WITH A BOTTOM CUTOUT AT A MINIMUM OF 32.5" FROM THE FLOOR.

NOTE: Additional clearance between cutouts may be required. Check to be sure that oven supports above the warming drawer location do not obstruct the required interior 23 1/2" depth and 9 1/4" height.

Installation below a double oven

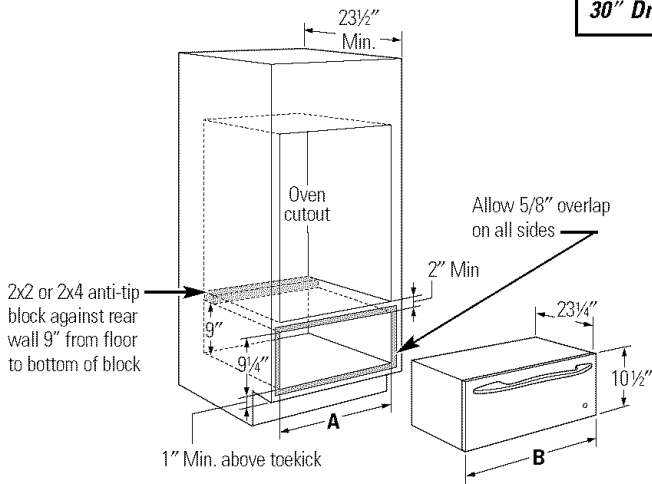

NOTE: Additional clearance between cutouts may be required. Check to be sure that oven supports above the warming drawer location do not obstruct the required interior 23 1/2" depth and 9 1/4" height.

	Dimension A	Dimension B
27" Drawer	25 1/2"	26 3/4"
30" Drawer	28 1/2"	30"

⚠ WARNING!
IN CANADA THIS DRAWER IS NOT APPROVED FOR INSTALLATION UNDER A DOUBLE OVEN.

■ When installed, the front face of the warming drawer will be nearly flush with cabinetry doors or drawer fronts.

■ Drawer overlaps will conceal cut edges on all sides of the opening.

The rough opening for the drawer must be:

—**Depth:** 23 1/2" minimum from inside back to front of cabinet frame.

—**Width:** 25 1/2" for 27" wide models
28 1/2" for 30" wide models.

—**Height:** 9 1/4"

—Allow 2" minimum between oven and drawer cutouts for clearance of overlaps.

NOTE: If you are installing in frameless cabinets, it may be necessary to install 1/2" wide cleats to accept drawer mounting screws. See drawer to find exact locations of mounting screws.

When installed under a wall oven:

Warming drawers are suitable for installation below only certain specified wall oven models. See the label attached to the top of the warming drawer for suitable models.

NOTE: Electrical receptacle can be installed as shown for countertop installations. Do not install receptacle above the top of the warming drawer cutout.

Installation of the warming drawer.

Read these instructions completely and carefully.



Provide Cabinet Support

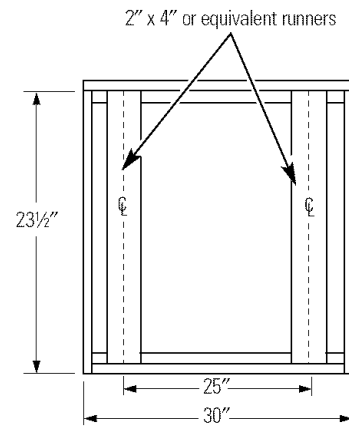
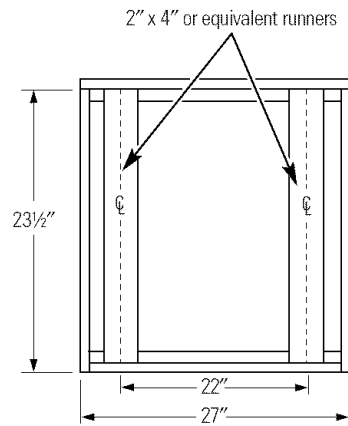

IMPORTANT: When installed below a single or double oven, check to be sure that any oven supports above the cutout do not obstruct the 23½" required depth of the warming drawer cutout.

- A 2" minimum clearance between oven and warming drawer cutouts are required. Additional clearance may be required if 2 x 4 blocks are used to support runners or solid floor of the oven above.
- The warming drawer may be supported by either a solid bottom, 2 x 4 or 2 x 2 runners.

- The support must be level and rigidly mounted, flush with the bottom edge of the cutout.

There is no way to level the drawer once it has been installed. Be sure supports are level.

- The entire weight of the drawer is supported by the runners or solid floor and must be capable of supporting 150 lbs.



Step 1—Install Anti-Tip Brace

WARNING: ANTI-TIP PRECAUTIONS:

The anti-tip brace must be installed to prevent the drawer from tipping forward when opened and loaded.

Failure to do so could result in personal injury.

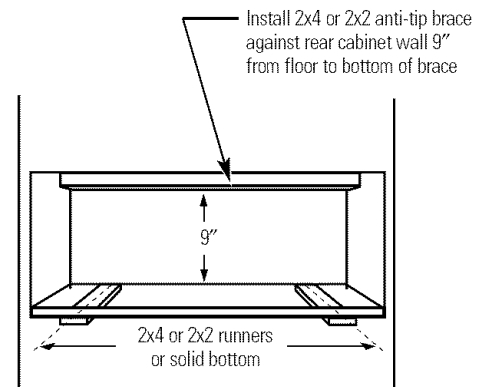

Read these instructions completely and carefully.

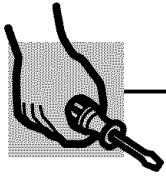

Step 2—Install Warming Drawer

- 1 Slide the left corner into opening and push power cord into the hole leading to the outlet location. Thread the cord through as drawer is being pushed back into the opening.

If the outlet is installed inside the opening, plug the cord into the outlet. In this location, the excess power cord should be coiled and taped to the right side of the unit. Make sure the cord does not get trapped by the drawer.

NOTE: Insure that the power cord does not contact the hot surfaces on the bottom of ovens, cooktops, or any other appliance.

- 2 Push the drawer back until the front flange is flush to the cabinet front.
- 3 Open the drawer fully.

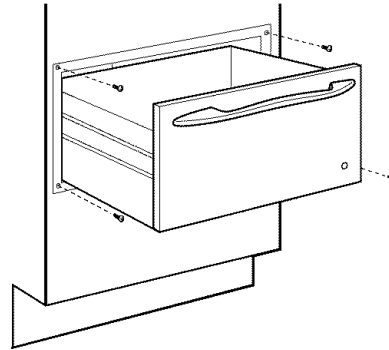

- 4 Drill pilot holes through the holes in the overlapping frame, one on each corner.
- 5 Drive wood screws provided into each corner.

Safety Instructions

Operating Instructions

Care and Cleaning

Installation Instructions

Troubleshooting Tips

Consumer Support

Before you call for service...



Troubleshooting Tips

Save time and money! Review the chart on this page first and you may not need to call for service.

Problem	Possible Causes	What To Do
Warming drawer will not work	A fuse in your home may be blown or the circuit breaker tripped.	<ul style="list-style-type: none"> • Replace the fuse or reset the circuit breaker.
	Warming drawer not plugged in.	<ul style="list-style-type: none"> • Plug in.
	Controls improperly set.	<ul style="list-style-type: none"> • See the <i>Using the warming drawer</i> section.
Drawer does not slide smoothly or drags	Ball bearings out of alignment.	<ul style="list-style-type: none"> • Fully extend the drawer and push it all the way in. See the <i>Care and cleaning</i> section.
	Drawer over-loaded or load unbalanced.	<ul style="list-style-type: none"> • Reduce weight to less than 50 pounds. Redistribute drawer contents.
Excessive condensation	Liquid in warming drawer.	<ul style="list-style-type: none"> • Remove liquid.
	Uncovered foods.	<ul style="list-style-type: none"> • Cover food with lid or aluminum foil.
	Temperature setting too high.	<ul style="list-style-type: none"> • Reduce temperature setting.
	Incorrect Moisture Selector setting.	<ul style="list-style-type: none"> • Set the Moisture Selector to the open vent setting to allow venting.
No heat in the PROOF setting	Room temperature may prevent the thermostat from tripping on.	<ul style="list-style-type: none"> • Turn the knob to LOW then back to PROOF.
Food dries out	Moisture escaping.	<ul style="list-style-type: none"> • Cover food with lid or aluminum foil.

Notes.

<i>Safety Instructions</i>	<i>Operating Instructions</i>	<i>Care and Cleaning</i>	<i>Installation Instructions</i>	<i>Troubleshooting Tips</i>	<i>Consumer Support</i>
----------------------------	-------------------------------	--------------------------	----------------------------------	-----------------------------	-------------------------

Consumer Support	Troubleshooting Tips	Installation Instructions	Care and Cleaning	Operating Instructions	Safety Instructions
-------------------------	-----------------------------	----------------------------------	--------------------------	-------------------------------	----------------------------

Notes.

GE Service Protection Plus™

GE, a name recognized worldwide for quality and dependability, offers you Service Protection Plus™—comprehensive protection on all your appliances—**No Matter What Brand!**

Benefits Include:

- Backed by GE
- All brands covered
- Unlimited service calls
- All parts and labor costs included
- No out-of-pocket expenses
- No hidden deductibles
- One 800 number to call

***We'll Cover Any Appliance.
Anywhere. Anytime.****

You will be completely satisfied with our service protection or you may request your money back on the remaining value of your contract. No questions asked. It's that simple.

Protect your refrigerator, dishwasher, washer and dryer, range, TV, VCR and much more—**any brand!** Plus there's no extra charge for emergency service and low monthly financing is available. Even icemaker coverage and food spoilage protection is offered. You can rest easy, knowing that all your valuable household products are protected against expensive repairs.

Place your confidence in GE and call us in the U.S. toll-free at **800.626.2224** for more information.

*All brands covered, up to 20 years old, in the continental U.S.

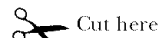

Please place in envelope and mail to:

General Electric Company
Warranty Registration Department
P.O. Box 32150
Louisville, KY 40232-2150

Consumer Product Ownership Registration

Dear Customer:

Thank you for purchasing our product and thank you for placing your confidence in us.

We are proud to have you as a customer!

Follow these three steps to protect your new appliance investment:

1

Complete and mail your Consumer Product Ownership Registration today. Have the peace of mind of knowing we can contact you in the unlikely event of a safety modification.

2

After mailing the registration below, store this document in a safe place. It contains information you will need should you require service. Our service number is 800.GE.CARES (800.432.2737).

3

Read your Owner's Manual carefully. It will help you operate your new appliance properly.

Model Number

Serial Number

Important: If you did not get a registration card with your product, detach and return the form below to ensure that your product is registered, or register online at www.GEAppliances.com.

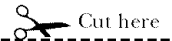

Consumer Product Ownership Registration



Model Number

Serial Number

Mr. Ms. Mrs. Miss

First Name

Last Name

Street Address

Apt. #

E-mail Address*

City State Zip Code

Date Placed In Use Month Day Year Phone Number --



GE Appliances

GE Consumer & Industrial
Louisville, Kentucky

* Please provide your e-mail address to receive, via e-mail, discounts, special offers and other important communications from GE Appliances (GEA).

Check here if you do not want to receive communications from GEA's carefully selected partners.

FAILURE TO COMPLETE AND RETURN THIS CARD DOES NOT DIMINISH YOUR WARRANTY RIGHTS.

For information about GEA's privacy and data usage policy, go to www.GEAppliances.com and click on "Privacy Policy" or call 800.626.2224.

Notes.

<i>Safety Instructions</i>	<i>Operating Instructions</i>	<i>Care and Cleaning</i>	<i>Installation Instructions</i>	<i>Troubleshooting Tips</i>	<i>Consumer Support</i>
----------------------------	-------------------------------	--------------------------	----------------------------------	-----------------------------	-------------------------

GE Electric Warming Drawer Warranty. *(For customers in the United States)*

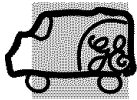

All warranty service provided by our Factory Service Centers, or an authorized Customer Care® technician. To schedule service, on-line, 24 hours a day, visit us at www.GEAppliances.com, or call 800.GE.CARES (800.432.2737).

Staple your receipt here.
Proof of the original purchase date is needed to obtain service under the warranty.

For The Period Of: **GE Will Replace:**

One Year

From the date of the
original purchase

Any part of the warming drawer which fails due to a defect in materials or workmanship. During this **full one-year warranty**, GE will also provide, **free of charge**, all labor and in-home service to replace the defective part.

What GE Will Not Cover:

- Service trips to your home to teach you how to use the product.
- Replacement of house fuses or resetting of circuit breakers.
- Improper installation, delivery or maintenance.
- Damage to the product caused by accident, fire, floods or acts of God.
- Failure of the product if it is abused, misused, or used for other than the intended purpose or used commercially.
- Incidental or consequential damage caused by possible defects with this appliance.
- Damage caused after delivery.

This warranty is extended to the original purchaser and any succeeding owner for products purchased for home use within the USA. In Alaska, the warranty excludes the cost of shipping or service calls to your home.

Some states do not allow the exclusion or limitation of incidental or consequential damages. This warranty gives you specific legal rights, and you may also have other rights which vary from state to state. To know what your legal rights are, consult your local or state consumer affairs office or your state's Attorney General.

Warrantor: General Electric Company, Louisville, KY 40225

GE Electric Warming Drawer Warranty. *(For customers in Canada)*

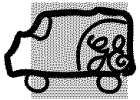

All warranty service provided by our Factory Service Centers or an authorized Customer Care® technician. For service, call 1.800.361.3400.

Staple your receipt here.
Proof of the original purchase date is needed to obtain service under the warranty.

For The Period Of: **Camco Will Replace:**

One Year

From the date of the original purchase

Any part of the warming drawer which fails due to a defect in materials or workmanship. During this **full one-year warranty**, Camco will also provide, **free of charge**, all labor and in-home service to replace the defective part.

What Camco Will Not Cover:

- Service trips to your home to teach you how to use the product.
- Improper installation, delivery or maintenance.
- Failure of the product if it is abused, misused, or used for other than the intended purpose or used commercially.
- Replacement of house fuses or resetting of circuit breakers.
- Damage to the product caused by accident, fire, floods or acts of God.
- Incidental or consequential damage caused by possible defects with this appliance.
- Damage caused after delivery.

WARRANTOR IS NOT RESPONSIBLE FOR CONSEQUENTIAL DAMAGES.

Warrantor: CAMCO INC.

Safety Instructions

Operating Instructions

Care and Cleaning

Installation Instructions

Troubleshooting Tips

Consumer Support

Consumer Support



GE Appliances Website

In the U.S.: www.GEAppliances.com

Have a question or need assistance with your appliance? Try the GE Appliances Website 24 hours a day, any day of the year! For greater convenience and faster service, you can now download Owner's Manuals, order parts, catalogs, or even schedule service on-line. You can also "Ask Our Team of Experts™" your questions, and so much more... **In Canada:** www.geappliances.ca

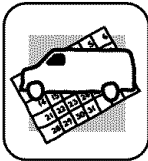

Schedule Service

In the U.S.: www.GEAppliances.com

Expert GE repair service is only one step away from your door. Get on-line and schedule your service at your convenience 24 hours any day of the year! Or call 800.GE.CARES (800.432.2737) during normal business hours. **In Canada,** call 1.800.361.3400

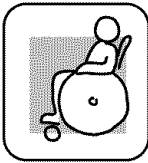

Real Life Design Studio

In the U.S.: www.GEAppliances.com

GE supports the Universal Design concept—products, services and environments that can be used by people of all ages, sizes and capabilities. We recognize the need to design for a wide range of physical and mental abilities and impairments. For details of GE's Universal Design applications, including kitchen design ideas for people with disabilities, check out our Website today. For the hearing impaired, please call 800.TDD.GEAC (800.833.4322).

In Canada, contact: Manager, Consumer Relations, Camco, Inc.
Suite 310, 1 Factory Lane
Moncton, N.B. E1C 9M3



Extended Warranties

In the U.S.: www.GEAppliances.com

Purchase a GE extended warranty and learn about special discounts that are available while your warranty is still in effect. You can purchase it on-line anytime, or call 800.626.2224 during normal business hours. GE Consumer Home Services will still be there after your warranty expires. **In Canada,** call 1.888.261.2133

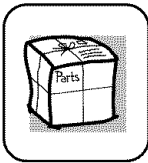

Parts and Accessories

In the U.S.: www.GEAppliances.com

Individuals qualified to service their own appliances can have parts or accessories sent directly to their homes (VISA, MasterCard and Discover cards are accepted). Order on-line today, 24 hours every day or by phone at 800.626.2002 during normal business hours.

Instructions contained in this manual cover procedures to be performed by any user. Other servicing generally should be referred to qualified service personnel. Caution must be exercised, since improper servicing may cause unsafe operation.

Customers **in Canada** should consult the yellow pages for the nearest Camco service center, or call 1.888.261.3055.

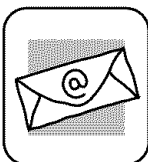

Contact Us

In the U.S.: www.GEAppliances.com

If you are not satisfied with the service you receive from GE, contact us on our Website with all the details including your phone number, or write to:

General Manager, Customer Relations
GE Appliances, Appliance Park
Louisville, KY 40225

In Canada: www.geappliances.ca, or write to: Director, Consumer Relations, Camco, Inc.
Suite 310, 1 Factory Lane
Moncton, N.B. E1C 9M3



Register Your Appliance

In the U.S.: www.GEAppliances.com

Register your new appliance on-line—at your convenience! Timely product registration will allow for enhanced communication and prompt service under the terms of your warranty, should the need arise. You may also mail in the pre-printed registration card included in the packing material. **In Canada:** www.geappliances.ca