

Advantium™

Built-In

Speedcook Ovens

Installation

Instructions

SCB2000, SCB2001
ZSC2000, ZSC2001

Before you begin — Read these instructions completely and carefully.
IMPORTANT - Save these instructions for local inspector’s use.
IMPORTANT - **OBSERVE ALL GOVERNING CODES AND ORDINANCES.**
 Note to Installer - Be sure to leave these instructions with the Consumer.
 Note to Consumer - Keep these instructions with your Owners Manual for future reference.
WARNING: This appliance must be properly grounded. See “Electrical Requirements,” page 5

If you received a damaged Oven, you should immediately contact your dealer or builder.

For Monogram local service in your area, 1-800-444-1845.

Proper installation is the responsibility of the installer. Product failure due to improper installation is not covered under the GE Appliance Warranty. See the Owners Manual for warranty information.

For Monogram service in Canada, call 1-888-880-3030.

For Monogram Parts and Accessories, call 1-800-626-2002.

- Use this appliance only for its intended purpose.

Check with local utilities for electrical codes that apply in your area. Local codes vary. Installation electrical connections and grounding must comply with applicable codes. In the absence of local codes, the oven should be installed in accordance with National Electrical Code ANSI/NFPA 70 or latest edition.

CAUTION:

- This oven should be installed by a qualified installer or service technician.
- Never use the oven for warming or heating a room. Prolonged use of the oven without adequate ventilation can be hazardous.

Contents

Design Information
 Product Dimensions 3
 Advance Planning 3
 Tools and Materials Required 3

Cabinetry
 Prepare the Opening 4
 Single Installation 4
 Installed Above a Single Oven 4
 Installed Above a Warming Drawer 4

Installation Preparation
 Electrical Requirements 5
 Install Junction Box 5

Installation
 Step 1: Remove Packaging and Parts 6
 Step 2: Route Conduit Through Cutout 6
 Step 3: Secure Oven to Cabinet 6
 Step 4: Connect Electrical 7

Design Information

Built-In Speedcook Ovens

Product Dimensions

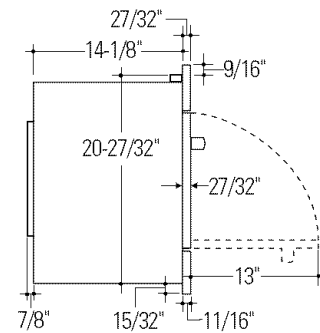
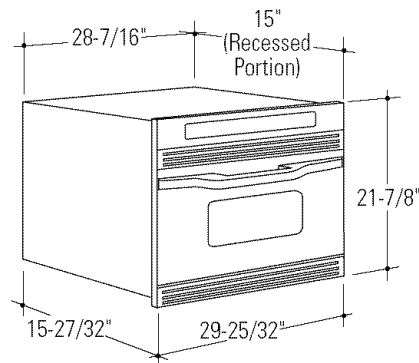

Models ZSC2001, ZSC2000

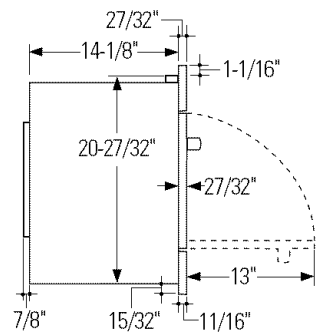
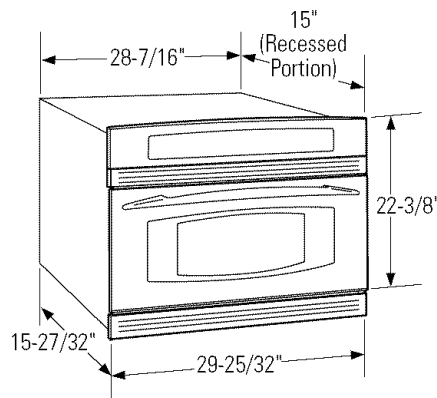

Models SCB2001, SCB2000

Advance Planning

- These ovens may be installed directly into a wall or wall oven cabinetry, 30" minimum width.
- The front surface of the oven will be nearly flush with surrounding cabinetry doors.
- This oven can be installed over any GE/Monogram single electric built-in oven or a single GE/Monogram electric built-in warming drawer.
- This oven must be installed at least 36" above the floor.

IMPORTANT: This oven is **not** approved for use above another built-in Speedcook oven, side by side or under the countertop installations.

- For personal safety, this oven cannot be installed in a cabinet arrangement such as an island or peninsula.
- Cabinets installed adjacent to wall ovens must have an adhesion spec of at least 194°F temperature rating.
- Allow for clearance to adjacent corners, walls, drawers, etc.

Tools and Materials Required

Tools and Materials Required:

- 2 x 4 or 2 x 2 lumber for runners
 - Saw
 - Level
 - Drill and 3/32" bit
 - Phillips screwdriver
- Wood screws and adhesive or other hardware for installing runners or shelf to support oven.

Electrical Requirements

- Junction box
- Electrical cable - 3-conductor or 4-conductor wire, as required by local codes.
- UL listed conduit connector
- Wire cutters and wire stripper

Prepare the Opening

Single Speedcook Installation

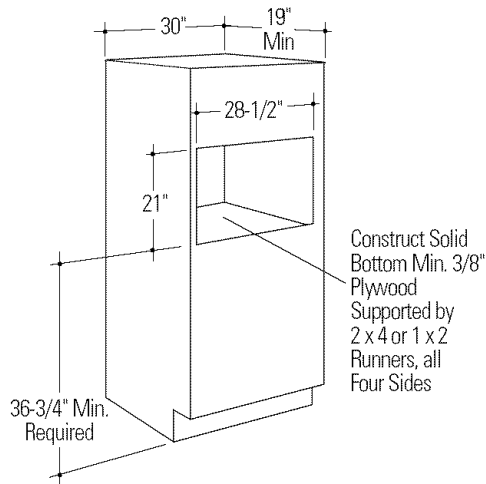

Order a 30" wide single oven cabinet or cut the opening in a wall to dimensions shown.

The rough opening must be:

- Depth - 19" Min.
- Width - 28-1/2" Min.
- Height - 21" Min.
- 36-3/4" from the floor to the cutout is required.
- **Monogram ovens ZSC2001 and ZSC2000** require 3/4" overlap on each side, top and bottom of the cutout.
- **GE ovens SCB2001 and SCB2000** require 3/4" overlap on each side and at the bottom. Allow 1-1/4" overlap at the top of the oven.
- Oven overlaps will conceal cut edges on all sides of the opening.

When installed over a single oven or a warming drawer, allow at least 2" between the two openings. This separation will provide clearance for bottom overlap of the Speedcook Oven and top overlap of the single oven or warming drawer.

- Construct a solid oven floor of 3/8" min. thick plywood supported by 2 x 4 or 1 x 2 runners on all sides.
- The support must be level and rigidly mounted, flush with the bottom edge of the cutout.



CAUTION

For personal safety, the mounting surface must be capable of supporting the cabinet load, in addition to the added weight of this approximate 100 pound product, plus, additional oven loads of up to 50 pounds or a total weight of 150 pounds.

Speedcook Oven Installed above a GE/Monogram Built-In Wall Oven

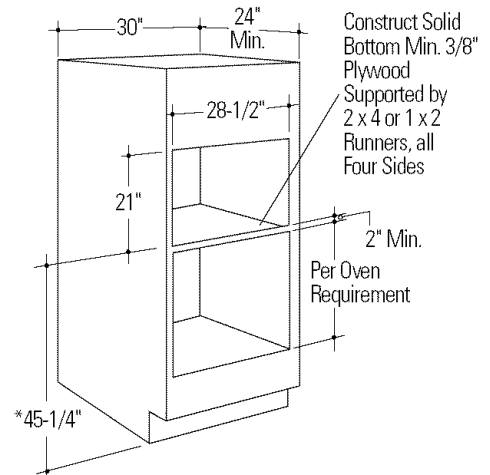

*If you are replacing a GE/Monogram electric double oven with the combined installation of a Speedcook and single wall oven, use the dimensions shown. The middle rail separating the two openings may need to be larger than the 2" min. shown.

- Always maintain 36-3/4" min. distance from the floor to the Speedcook oven cutout in any installation combination.

Speedcook Oven Installed above a GE/Monogram Warming Drawer

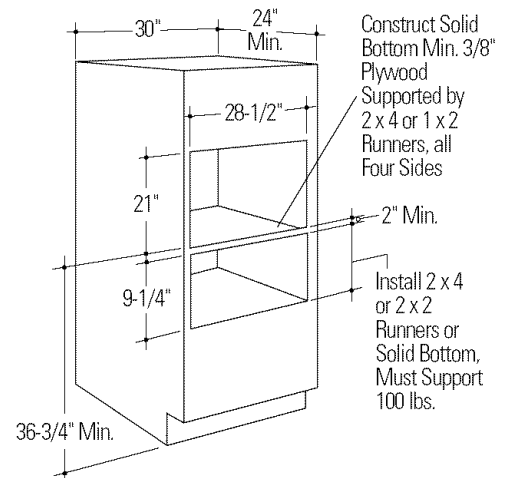

Note: Additional clearance between the cutouts may be required. Check to be sure the oven supports above the Warming Drawer location does not obstruct the required interior 23-1/2" depth and 9-1/4" height. See installation instructions for details.

When installing the Speedcook oven over a GE/Monogram electric warming drawer, follow the product installation instructions.

- An anti-tip block must be installed at the rear of the warming drawer opening. Again, see installation instructions for complete details.

Installation Preparation

Built-In Speedcook Ovens

Electrical Requirements

Single Speedcook Installation

Product rating is 120/208 or 120/240 volt, 60 Hz, 30 amps. This product must be connected to a supply circuit of the proper voltage and frequency and protected by a time delay fuse or circuit breaker. The power supply should be brought to a separate 30 ampere branch circuit. Wire size must conform to the requirements of the National Electric Code or the prevailing local code.

Combined Speedcook and Wall Oven Installation:

When installed in combination with a GE/Monogram single wall oven, use separate electrical junction boxes, OR,

Install a single junction box connected to 50 amp. supply circuit or properly rated supply circuit.

- Refer to single oven installation instructions for electrical requirements of that product.
- These connections must be made by a qualified electrician. All electrical connections must meet National Electrical code or prevailing local codes.

Combined Speedcook and Warming Drawer installation:

When installing the Speedcook oven over a GE/Monogram electric warming drawer, a separate 120V, 60Hz, properly grounded receptacle must be installed. See instructions packed with the warming drawer.



Electrical Shock Hazard

- The electrical power to the oven branch circuit must be shut off while line connections are being made.
- Use copper wiring only.
- Electrical ground is required on this appliance. The free end

of the green wire (the ground wire) must be connected to a suitable ground. This wire must remain grounded to the oven.

- If cold water pipe is interrupted by plastic, non-metallic gaskets, union connections or other insulating materials, DO NOT use for grounding.
 - DO NOT ground to a gas pipe.
 - DO NOT have a fuse in the NEUTRAL or GROUNDING circuit. A fuse in the NEUTRAL or GROUNDING circuit could result in an electrical shock.
 - Check with a qualified electrician if you are in doubt as to whether the appliance is properly grounded.
- Failure to follow these instructions could result in serious injury or death.

Install Junction Box

The conduit is located at the top right on the back of the oven.

- Locate and install the junction box within reach of the oven conduit.
 - Through the left or right sides of the cabinet wall and into adjacent cabinet.
 - Or, through the cutout floor.
 - Or, in the upper cabinet.

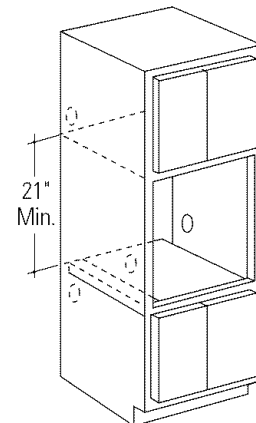

Installation

Built-In Speedcook Ovens

Step 1 *Remove Packaging and Parts*

- Open the door and remove packing material with ceramic tray.
- Locate owners kit in carton. Remove and save.
- Locate box with metal trays in carton. Remove and save.
- Locate parts package containing 5 mounting screws. (4 required, 1 extra)

IMPORTANT: To protect the bottom trim, do not remove the styrofoam shipping base until the oven is slipped into the opening.

Step 2 *Route Conduit Through Cutout*

CAUTION 2 people are required to lift the oven into the opening. Grasp the bottom at front and rear. Discard styrofoam base. **DO NOT USE HANDLE TO LIFT THE OVEN. DAMAGE WILL OCCUR!**

- With oven in front of the cabinet opening:
- Insert conduit into cabinet opening.
 - Lift the oven into the opening while continuing to feed the conduit in the direction of the installed junction box. Be sure the conduit does not get pinched between the back of the oven and the cabinet wall.

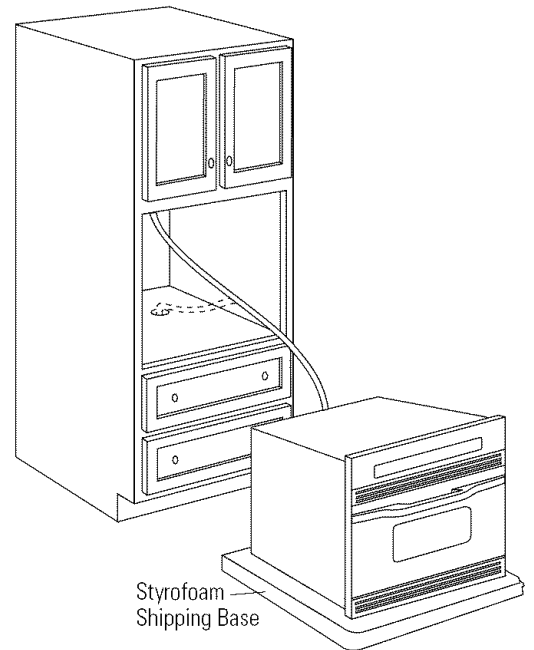

Step 3 *Secure Oven to Cabinet*

- Slide oven into the cabinet opening.
- Drill 3/32" pilot holes into the cabinet frame through the 4 mounting holes in the oven front frame.
- Secure oven to cabinet with screws supplied.

WARNING Securely fasten oven to cabinet using the screws provided. Failure to do so could cause the oven to move or tip during use and result in personal injury.

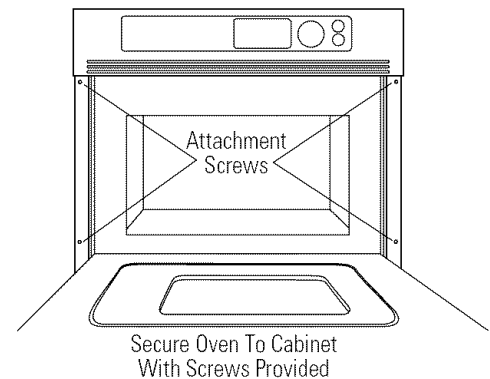

Step
4
*Connect
Electrical*



Electrical Shock Hazard

- Electrical ground is required on the appliance.
- Do not connect the electrical supply until appliance is permanently grounded.
- Disconnect power to the junction box before making the electrical connection.
- This appliance must be grounded to a metallic, permanent wiring system, or a grounding connector should be connected to the

grounding terminal or wire lead on the appliance. Failure to do so could result in fire, personal injury or electrical shock.

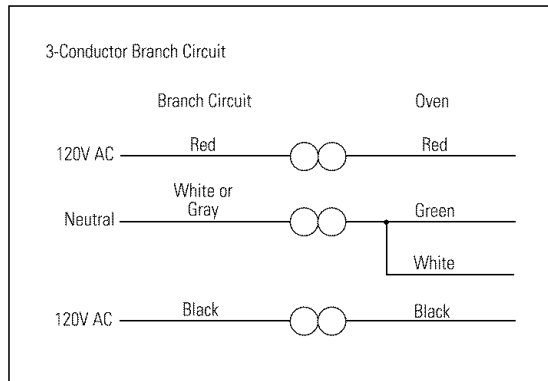

When connecting to a 3-conductor branch circuit:

- Connect oven red lead to branch circuit red lead.
- Connect oven black lead to branch circuit black lead.
- Connect oven green ground lead and white lead to branch circuit neutral (white or gray).

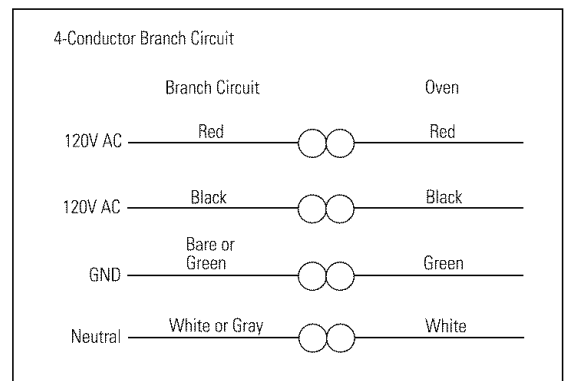

When connecting to a 4-conductor branch circuit:

- Connect oven red lead to branch circuit red lead.
- Connect oven black lead to branch circuit black lead.
- Break connection between oven white lead and oven green ground lead.
- Connect oven white lead to branch circuit neutral lead (white or gray).
- Connect oven green ground lead to branch circuit ground lead (green or bare copper).

