

TOSHIBA



OWNER'S MANUAL

Projection Monitor

COLORSTREAM® SRS WOW HDMI
THEATERWIDE HD HDTV MONITOR

51HC85

57HC85

65HC85

Owner's Record

The model number and serial number are on the back of your monitor. Record these numbers in the spaces below. Refer to these numbers whenever you communicate with your Toshiba dealer about this monitor.

Model: _____

Serial No.: _____



© 2005 TOSHIBA CORPORATION
All Rights Reserved

Introduction

Connecting your Monitor

Using the remote control

Setting up your Monitor

Operating your Monitor

Appendix

Index

Dear Customer,

Thank you for purchasing this Toshiba monitor. This manual will help you use the many exciting features of your new monitor. **Before operating the monitor, please read this manual completely**, and keep it nearby for future reference.

NOTE: THIS MONITOR DOES NOT CONTAIN A TUNER.

A set-top box (i.e., cable box or analog/digital receiver) is required to receive: (1) analog and/or digital broadcast signals from an antenna; and (2) analog and/or digital cable. For more information, refer to the applicable connection and setup instructions in this owner's manual.

Safety Precautions

WARNING

TO REDUCE THE RISK OF FIRE OR ELECTRIC SHOCK, DO NOT EXPOSE THIS APPLIANCE TO RAIN OR MOISTURE.



WARNING
RISK OF ELECTRIC SHOCK
DO NOT OPEN



WARNING: TO REDUCE THE RISK OF ELECTRIC SHOCK, DO NOT REMOVE COVER (OR BACK). NO USER-SERVICEABLE PARTS INSIDE. REFER SERVICING TO QUALIFIED SERVICE PERSONNEL.



The lightning symbol in the triangle tells you that the voltage inside this product may be strong enough to cause an electric shock. **DO NOT TRY TO SERVICE THIS PRODUCT YOURSELF.**



The exclamation mark in the triangle tells you that important operating and maintenance instructions follow this symbol.

NOTICE OF POSSIBLE ADVERSE EFFECTS ON MONITOR PICTURE DISPLAY

If a fixed (non-moving) pattern or image remains on the monitor screen for extended periods of time, the image can become permanently ingrained in the cathode ray tube(s) of the monitor and cause subtle but permanent ghost images.

This type of damage is NOT COVERED BY YOUR WARRANTY. See item 33 on page 4 for details.



ENERGY STAR® qualified monitor. Products that earn the ENERGY STAR prevent green house gas emissions by meeting strict energy efficiency guidelines set by the U.S. Environmental Protection Agency and the U.S. Department of Energy. ENERGY STAR and the ENERGY STAR mark are registered U.S. marks.



NOTE: NEVER CONNECT THIS MONITOR TO A PERSONAL COMPUTER (PC). THIS MONITOR IS NOT INTENDED FOR USE WITH A PC.

2

Child Safety

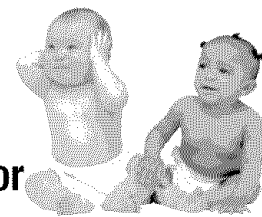

It Makes A Difference Where Your TV/monitor Stands

Congratulations on your purchase! As you enjoy your new TV/monitor, keep these safety tips in mind:

The Issue

- If you are like most consumers, you have a TV/monitor in your home. Many homes, in fact, have more than one TV/monitor.
- The home theater entertainment experience is a growing trend, and larger TVs/monitors are popular purchases; however, they are not always supported on the proper TV/monitor stands.
- Sometimes TVs/monitors are improperly secured or inappropriately situated on dressers, bookcases, shelves, desks, audio speakers, chests, or carts. As a result, TVs/monitors may fall over, causing unnecessary injury.



Toshiba Cares!

- The consumer electronics industry is committed to making home entertainment enjoyable and safe.
- The Consumer Electronics Association formed the Home Entertainment Support Safety Committee, comprised of TV/monitor and consumer electronics furniture manufacturers, to advocate children's safety and educate consumers and their families about TV/monitor safety.

Tune Into Safety

- One size does NOT fit all! Use appropriate furniture large enough to support the weight of your TV/monitor (and other electronic components).
- Use appropriate angle braces, straps, and anchors to secure your furniture to the wall (but never screw anything directly into the TV/monitor).
- Carefully read and understand the other enclosed instructions for proper use of this product.
- Do not allow children to climb on or play with furniture and TVs/monitors.
- Avoid placing any item on top of your TV/monitor (such as a VCR, remote control, or toy) that a curious child may reach for.
- Remember that children can become excited while watching a program and can potentially push or pull a TV/monitor over.
- Share our safety message about this hidden hazard of the home with your family and friends. Thank you!



2500 Wilson Blvd.
Arlington, VA 22201 U.S.A.
Tel. 703-907-7600 Fax 703-907-7690
www.CE.org

CEA is the Sponsor, Producer and Manager of the International CES®

Important Safety Instructions

- 1) **Read these instructions.**
- 2) **Keep these instructions.**
- 3) **Heed all warnings.**
- 4) **Follow all instructions.**



- 5) **Do not use this apparatus near water.**

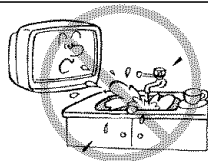

- 6) **Clean only with a dry cloth.**

- 7) **Do not block any ventilation openings.** Install in accordance with the manufacturer's instructions.

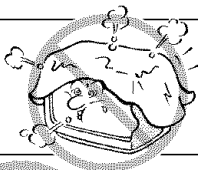

- 8) **Do not install near any heat sources** such as radiators, heat registers, stoves, or other apparatus (including amplifiers) that produce heat.

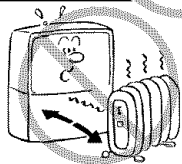

- 9) **Do not defeat the safety purpose of the polarized or grounding type plug.** A polarized plug has two blades with one wider than the other. A grounding type plug has two blades and a third grounding prong. The wide blade or the third prong are provided for your safety. If the provided plug does not fit into your outlet, consult an electrician for replacement of the obsolete outlet.

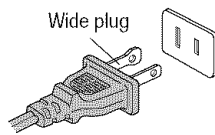

- 10) **Protect the power cord** from being walked on or pinched, particularly at plugs, convenience receptacles, and the point where it exits the apparatus.

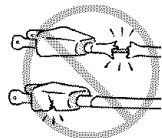

- 11) **Only use attachments/accessories specified by the manufacturer.**

- 12) **Use only with the cart, stand, tripod, bracket, or table specified by the manufacturer, or sold with the apparatus.** When a cart is used, use caution when moving the cart/apparatus combination to avoid injury from tip-over.



- 13) **Unplug this apparatus during lightning storms or when unused for long periods of time.**

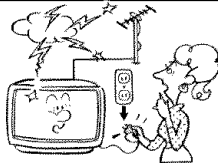

- 14) **Refer all servicing to qualified service personnel.**

Servicing is required when the apparatus has been damaged in any way, such as power supply cord or plug is damaged, liquid has been spilled or objects have fallen into the apparatus, the apparatus has been exposed to rain or moisture, does not operate normally, or has been dropped.

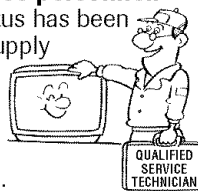

- 15) **CAUTION:** To reduce the risk of electric shock, do not use the polarized plug with an extension cord, receptacle, or other outlet unless the blades can be inserted completely to prevent blade exposure.

Installation, Care, and Service

Installation

Follow these recommendations and precautions and heed all warnings when installing your monitor:

- 16) Never modify this equipment. Changes or modifications may void: a) the warranty, and b) the user's authority to operate this equipment under the rules of the Federal Communications Commission.

- 17) **! DANGER: RISK OF SERIOUS PERSONAL INJURY, DEATH, OR EQUIPMENT DAMAGE!** Never place the monitor on an unstable cart, stand, or table. The monitor may fall, causing serious personal injury, death, or serious damage to the monitor.



- 18) Never place or store the monitor in direct sunlight; hot, humid areas; areas subject to excessive dust or vibration; or locations with temperatures at or below 41°F (5°C).

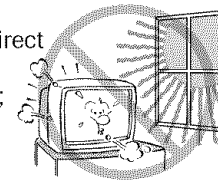

- 19) Always place the monitor on the floor or a sturdy, level, stable surface that can support the weight of the unit.

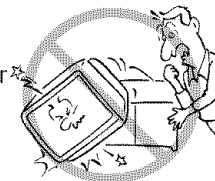

- 20) Never place items such as vases, aquariums, or candles on top of the monitor.

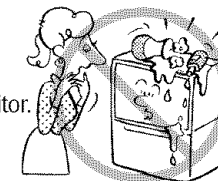

- 21) Never block or cover the slots or openings in the monitor cabinet back, bottom, and sides. Never place the monitor:

- on a bed, sofa, rug, or similar surface;
- too close to drapes, curtains, or walls; or

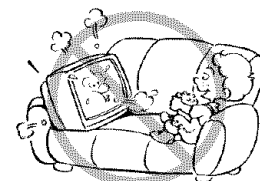

- in a confined space such as a bookcase, built-in cabinet, or any other place with poor ventilation.

The slots and openings are provided to protect the monitor from overheating and to help maintain reliable operation of the monitor.

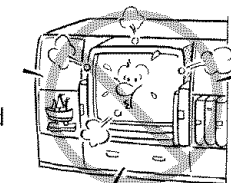

- 22) Never allow anything to rest on or roll over the power cord, and never place the monitor where the power cord is subject to wear or abuse.

- 23) Never overload wall outlets and extension cords.

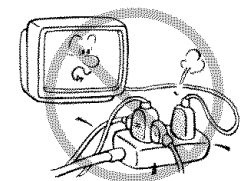

24) Always operate this equipment from a 120 VAC, 60 Hz power source only.

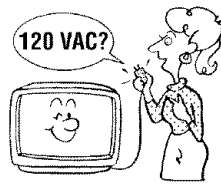

25) Always make sure the antenna system is properly grounded to provide adequate protection against voltage surges and built-up static charges (see Section 810 of the National Electric Code).

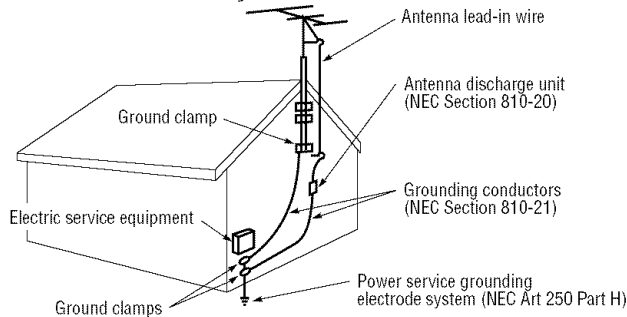

26) **! DANGER: RISK OF SERIOUS PERSONAL INJURY OR DEATH!**

- Use extreme care to make sure you are never in a position where your body (or any item you are in contact with, such as a ladder or screwdriver) can accidentally touch overhead power lines. Never locate the antenna near overhead power lines or other electrical circuits.
- Never attempt to install any of the following during lightning activity:
 - a) an antenna system; or b) cables, wires, or any home theater component connected to an antenna or phone system.

Care

For better performance and safer operation of your TOSHIBA monitor, follow these recommendations and precautions:

27) Always sit approximately 10–25 feet away from the monitor and as directly in front of it as possible. The picture can appear dull if you sit too far to the left or right of the monitor, or if sunlight or room lights reflect on the screen. Turn the monitor off to check for reflections on the screen, and then remove the source of reflections while viewing the monitor.

28) Always unplug the monitor before cleaning. Never use liquid or aerosol cleaners.

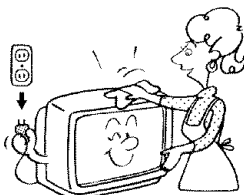

29) **! WARNING: RISK OF ELECTRIC SHOCK!** Never spill liquids or push objects of any kind into the monitor cabinet slots.

4

30) [This item applies to projection monitors only.] If the air temperature rises suddenly (for example, when the monitor is first delivered), condensation may form on the lenses. This can make the picture appear distorted or the color appear faded. If this happens, turn off the monitor for 6 to 7 hours to allow the condensation to evaporate.

31) For added protection of your monitor from lightning and power surges, always unplug the power cord if you leave the monitor unattended or unused for long periods of time.

32) During normal use, the monitor may make occasional snapping or popping sounds. This is normal, especially when the unit is being turned on or off. If these sounds become frequent or continuous, unplug the power cord and contact a Toshiba Authorized Service Center.

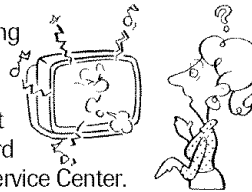

33) **Possible Adverse Effects on Monitor Picture Display:** If a fixed (non-moving) pattern or image remains on the monitor screen for extended periods of time, the image can become permanently ingrained in the cathode ray tube(s) of the monitor and cause subtle but permanent ghost images. **This type of damage is NOT COVERED BY YOUR WARRANTY.** Never leave the monitor on for extended periods of time while it is displaying the following images or formats:

- **Fixed Images**, including but not limited to PIP/POP windows, closed captions, video game patterns, TV station logos, stock tickers, and websites.
- **Special Formats** that do not use the entire screen, including but not limited to widescreen or letterbox format media viewed on a 4:3 aspect ratio display (with gray or black bars at the top and bottom of the screen); or 4:3 aspect ratio format media viewed on a widescreen/16:9 aspect ratio display (with gray or black bars on the left and right sides of the screen).

Service

34) **! WARNING: RISK OF ELECTRIC SHOCK!** Never attempt to service the monitor yourself. Opening and removing the covers may expose you to dangerous voltage or other hazards. Refer all servicing to a Toshiba Authorized Service Center.

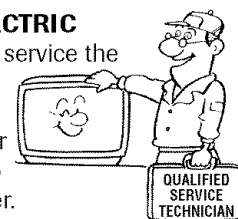

35) If you have the monitor serviced:

- Ask the service technician to use only replacement parts specified by the manufacturer.
- Upon completion of service, ask the service technician to perform routine safety checks to determine that the monitor is in safe operating condition.

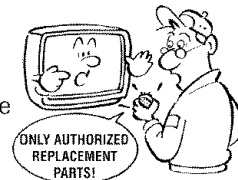

36) When the monitor reaches the end of its useful life, ask a qualified service technician to properly dispose of the monitor. Improper disposal may result in a picture tube implosion and possible personal injury.

FCC compliance information

Federal Communications Commission (FCC)

This equipment complies with Part 15 of the FCC rules.

NOTE: This equipment has been tested and found to comply with the limits for a Class B device, pursuant to Part 15 of the FCC rules. These limits are designed to provide reasonable protection against harmful interference in a residential installation. This equipment generates, uses, and can radiate radio frequency energy and, if not installed and used in accordance with the instructions, may cause harmful interference to radio communications. However, there is no guarantee that interference will not occur in a particular installation. If this equipment does cause harmful interference to radio or television reception, which can be determined by removing and applying power

to the equipment, the user is encouraged to try to correct the interference by one or more of the following measures:

- Reorient or relocate the receiving antenna.
- Increase the separation between the equipment and the receiver.
- Connect the equipment into an outlet on a circuit different from that to which the receiver is connected.
- Consult the dealer or an experienced radio/TV technician for help.

Changes or modifications to this equipment not expressly approved by Toshiba could void the user's authority to operate this equipment.

Important Safety Precautions for Split Cabinet Feature

(Models 57HC85 and 65HC85 only)

Toshiba monitor models 57HC85 and 65HC85 have a split cabinet feature that allows disassembly of the cabinet into two sections during installation.

For details, please refer to the insert titled "Disassembly/ Reassembly Instructions for Split Cabinet Feature" included with this owner's manual in the accessory pack. If you do not have the insert, you can download a copy of it from our Web site (www.toshiba.com/tacp in the U.S.A. or www.toshiba.ca in Canada). If you do not have access to the Internet, call 1-800-631-3811 in the U.S.A.



WARNING: If you split the cabinet for any purpose, **NEVER** energize the bottom section until it is completely and properly installed. Energizing the disassembled bottom section and subjecting it to intentional misuse (for example, exposing it to a foreign object) creates the potential for an electrical shock hazard that could result in death or serious injury.

CAUTION: If you use the split cabinet feature, **ALWAYS** handle and treat the top section of the monitor cabinet, which contains a glass mirror, with great care. If subjected to excessive mechanical abuse (for example, if bumped or dropped), the mirror may break, creating exposed glass fragments with sharp edges. Contact with these glass fragments may result in injury.

Installation, Care, and Service

CAUTION: The split cabinet feature allows disassembly of the cabinet into two sections during installation. If you use the split cabinet feature, follow these precautions while the two sections of the monitor cabinet are disassembled:

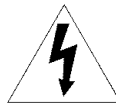
- 1) Always handle and treat the top section of the monitor cabinet (with the viewing screen), which contains a glass mirror, with great care. If subjected to excessive mechanical abuse (for example, if bumped or dropped), the mirror may break, creating exposed glass fragments with sharp edges. Contact with these glass fragments may result in injury.
- 2) Never temporarily locate the disassembled bottom section in an area where it may be exposed to foreign objects or abuse (for example, areas where children may be playing, where items may fall on top of the unit, or where liquids may spill into the unit). Failure to follow this instruction may result in damage to the optic components of the monitor. **SUCH DAMAGE IS NOT COVERED UNDER THE TOSHIBA LIMITED WARRANTY.**
- 3) Always keep the top and bottom sections of the monitor cabinet in an upright position while disassembled. Failure to follow this instruction may result in damage to the monitor, including but not limited to the optic components, cabinet, bezel, and glass mirror. **SUCH DAMAGE IS NOT COVERED UNDER THE TOSHIBA LIMITED WARRANTY.**
- 4)  **Never energize the bottom section of the monitor cabinet while disassembled. Failure to follow this instruction could result in death or serious injury.**
- 5) Never place anything on top of the disassembled bottom section of the monitor cabinet. Failure to follow this instruction may result in damage to the optic components. **SUCH DAMAGE IS NOT COVERED UNDER THE TOSHIBA LIMITED WARRANTY.**
- 6) Never store or transport the unit while it is disassembled. Failure to follow this instruction may result in damage to the monitor, including but not limited to the optic components, cabinet, bezel, and glass mirror. **SUCH DAMAGE IS NOT COVERED UNDER THE TOSHIBA LIMITED WARRANTY.**

Important Safety Information	2-5		
Introduction.....	7		
Welcome to Toshiba	7		
Exploring your new monitor	7		
Connecting your Monitor	8		
Connecting a VCR	9		
Connecting a cable converter box and VCR	10		
Connecting a DVD player or satellite receiver and a VCR	11		
Connecting a DVD player with ColorStream® (component video) and a VCR	12		
Connecting a DTV receiver/set-top box with ColorStream® (component video) and a VCR	13		
Connecting two VCRs	14		
Connecting a camcorder	14		
Connecting an HDMI™ or a DVI device to the HDMI input	15		
Controlling infrared remote-controlled devices through the monitor (IR pass-through)	16		
Connecting an audio system	17		
Using the remote control	18		
Preparing the remote control for use	18		
Installing the remote control batteries	18		
Remote control effective range	18		
Learning about the remote control	19		
Using the remote control to operate your other devices ..	20		
Remote control function key chart	21		
Programming the remote control to operate your other devices	22		
Remote control codes	22		
Setting up your Monitor	24		
Turning on the Monitor	24		
Learning about the menu system	24		
Changing the on-screen display language	25		
Adjusting the color convergence	25		
Operating your Monitor	27		
Viewing the wide-screen picture formats (480i, 480p, and 1080i signals only)	27		
Selecting the picture size	27		
Scrolling the TheaterWide® picture (TheaterWide 2 and 3 only)	29		
Using the AUTO ASPECT feature	30		
Using the POP double-window feature	31		
Swapping the main and POP pictures	32		
Switching the speaker sound (main or POP program)	32		
Double-Window aspect ratio	32		
		Using the LOCKS menu	33
		Entering the PIN code	33
		If you cannot remember your PIN code	33
		Using the V-CHIP menu	33
		ENABLE BLOCKING	34
		TV RATING (Independent rating system for broadcasters)	34
		MPAA RATING (Independent rating system for movies)	35
		BLOCKING OPTION	35
		Changing the PIN code	36
		Adjusting the picture	36
		Selecting the picture mode	36
		Adjusting the picture quality	37
		Saving your new preferences	37
		Selecting the color temperature	38
		Using the CableClear® DNR feature	38
		Resetting your picture setting adjustments	39
		Selecting the display format (for 480p signals only)	39
		Selecting the cinema mode	39
		Selecting the video input source	40
		Labeling the video input sources	40
		Using the closed caption feature	41
		Setting the sleep timer	42
		Setting the clock	42
		Adjusting the sound	43
		Muting the sound	43
		Using the WOW® surround sound feature	43
		Adjusting the sound quality	44
		Resetting your audio adjustments	44
		Using the StableSound® feature	45
		Turning off the built-in speakers	45
		Selecting the Audio OUT sound	46
		Selecting the background of the menu display	46
		Displaying monitor status information on-screen	47
		Understanding the last mode memory feature	47
		Appendix.....	48
		Specifications	48
		Troubleshooting	49
		Limited United States Warranty	50
		Index	51

Introduction

Welcome to Toshiba

Thank you for purchasing this Toshiba Monitor, one of the innovative projection monitors on the market. The goal of this manual is to guide you through setting up and operating your Toshiba monitor as quickly as possible.

This manual applies to models 51HC85, 57HC85, and 65HC85. Before you start reading, check the model and serial numbers on the back of your monitor. Write these numbers in the space provided on the front cover of this manual for your records.

Instructions in this manual are based on using the remote control. You also can use the controls on the monitor's front panel if they have the same name as those on the remote control.

Please read all the safety and operating instructions carefully, and keep the manual for future reference.

Exploring your new monitor

You can operate your monitor using the buttons on the front panel or the remote control. The back panel and front panel (behind the door) provide all the terminal connections you will need to connect other equipment to your monitor. See "Connecting your Monitor" on page 8. Illustrations represent 57HC85.

NOTE: THIS MONITOR DOES NOT CONTAIN A TUNER.

A set-top box (i.e., cable box or analog/digital receiver) is required to receive: (1) analog and/or digital broadcast signals from an antenna; and (2) analog and/or digital cable.

For more information, refer to the applicable connection and setup instructions in this owner's manual.

THIS MONITOR REQUIRES COLOR CONVERGENCE ADJUSTMENT AFTER SETTING UP.

Convergence may drift as a result of relocating or adjusting the position of the MONITOR. After setting up your MONITOR, it is recommended that you set the convergence. For instructions on adjusting the color convergence, see page 25.

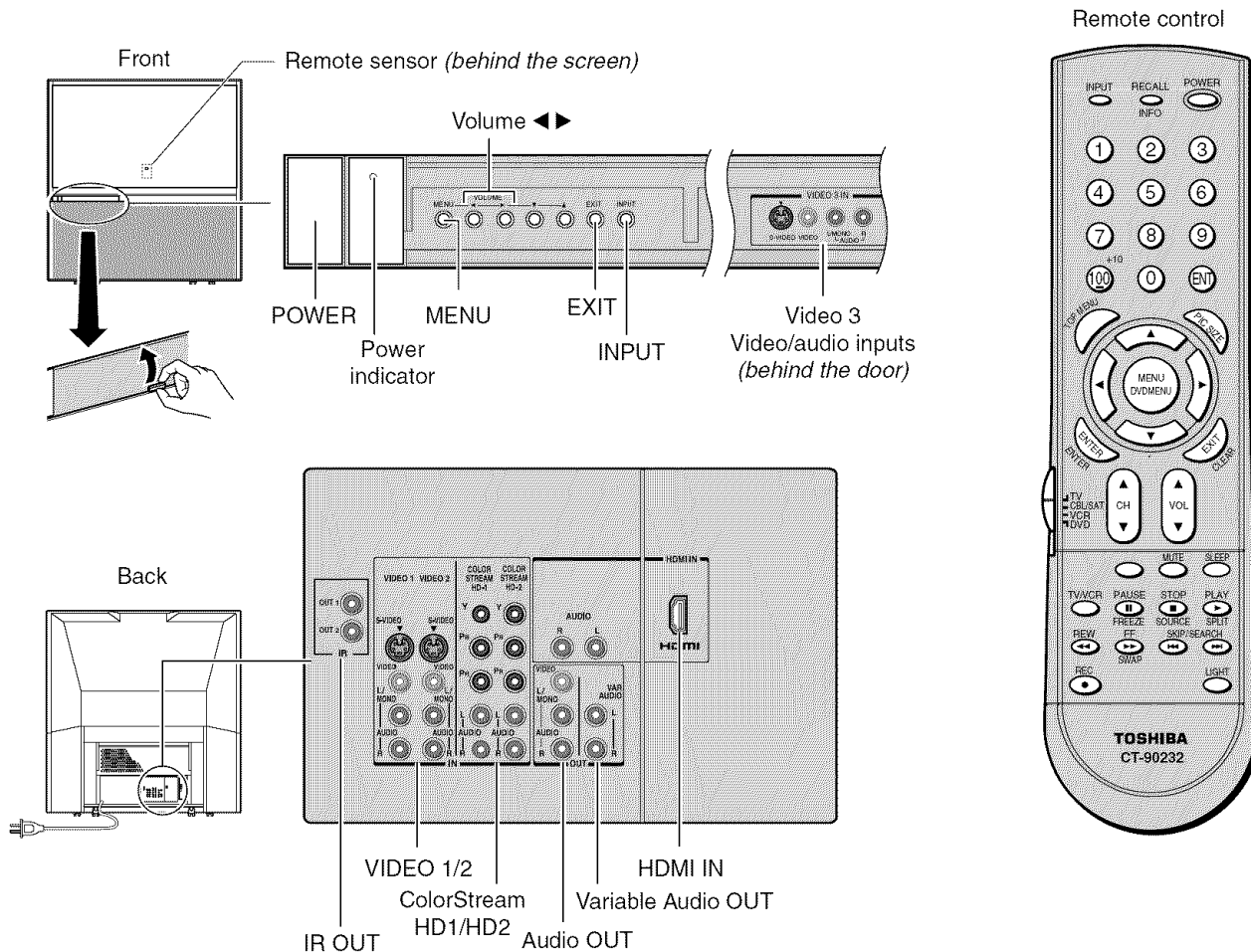

Connecting your Monitor

Note: Cables except for Dual-wand IR blaster cable are not supplied with your monitor.

- **Standard A/V (audio/video) cables** usually come in sets of three, and are typically color-coded according to use: yellow for video, red for stereo right audio, and white for stereo left (or mono) audio. On your monitor's back panel, the standard A/V inputs are color-coded in the same manner as the cables.
- **S-video cable** is for use with video equipment that has an S-video input.
- **Component video cables** come in sets of three, and are for use with video equipment that has component video inputs. (ColorStream® is Toshiba's brand of component video.)
- **HDMI cable** is for use with video equipment that has an HDMI type A connector (see page 15).
- **Dual-wand IR blaster cable** is for use with video devices with IR (infrared) remote control. This can be used with the monitor's IR pass-through feature (see page 16).

Note: The IR blaster cable included with your monitor has specific characteristics that allows them to work properly with this monitor's IR OUT ports. **Never use other aftermarket IR blaster cable with this monitor.** Other cables may not function properly and can cause damage. **THIS TYPE OF DAMAGE IS NOT COVERED BY YOUR TOSHIBA WARRANTY.**

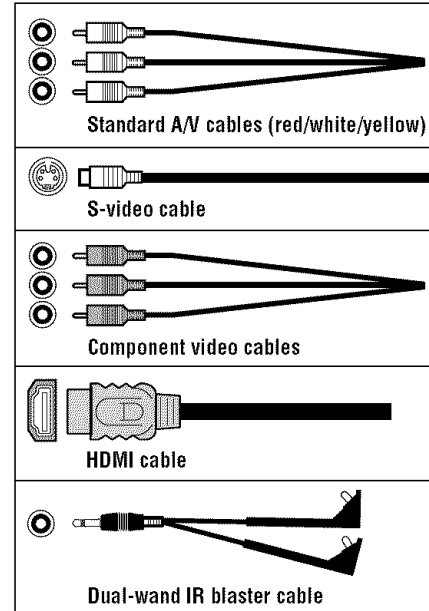

NOTE REGARDING PICTURE QUALITY

When connecting video equipment to your Toshiba monitor:

- **For GOOD picture quality:** Use a standard yellow video cable.
- **For BETTER picture quality:** If your equipment has an S-video input, use an S-video cable **instead of** a standard yellow video cable. (You still must connect the standard red and white audio cables for full system connection, but do not connect the standard yellow video cable at the same time, or the picture performance will be unacceptable.)
- **For BEST picture quality:** If your equipment has component video (or HDMI) inputs, use either component video cables (or an HDMI cable) **instead of** a standard video or S-video cable. (A component video connection requires separate audio cables. An HDMI connection does not require separate audio cables.)



NOTICE:

RISK OF EQUIPMENT DAMAGE!

Do not plug in any power cords until you have finished connecting all equipment.

Connecting a VCR

This connection allows you to watch video tapes.

You will need:

- one set of standard A/V cables

From Cable Box or Antenna

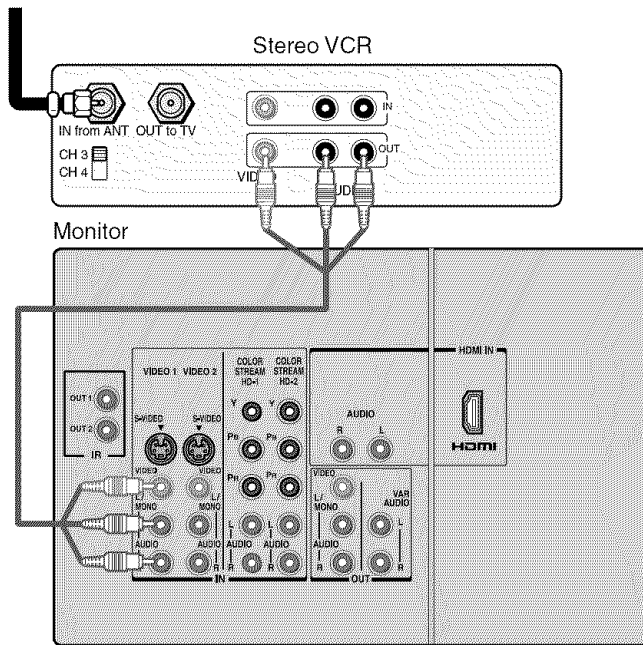

Note:

If you have a mono VCR, connect L/Mono to VCR Audio OUT using only one audio cable.

If you have a VCR with S-video, use an S-video cable (in the S-video terminals) instead of the standard video cable.

Do not connect a standard video cable and an S-video cable to Video-1 (or Video-2) at the same time, or the picture performance will be unacceptable.

The unauthorized recording, use, distribution, or revision of television programs, videotapes, DVDs, and other materials is prohibited under Copyright Law of the United States and other countries, and may subject you to civil and criminal liability.

Connecting a cable converter box and VCR

This connection allows you to watch basic and premium cable channels and watch video tapes. To watch basic and premium cable channels, put the monitor in VIDEO 1 mode and set the VCR to channel 3 or 4 (whichever channel is vacant in your area), and use the converter box to change channels.

You will need:

- two coaxial cables
- one set of standard A/V cables

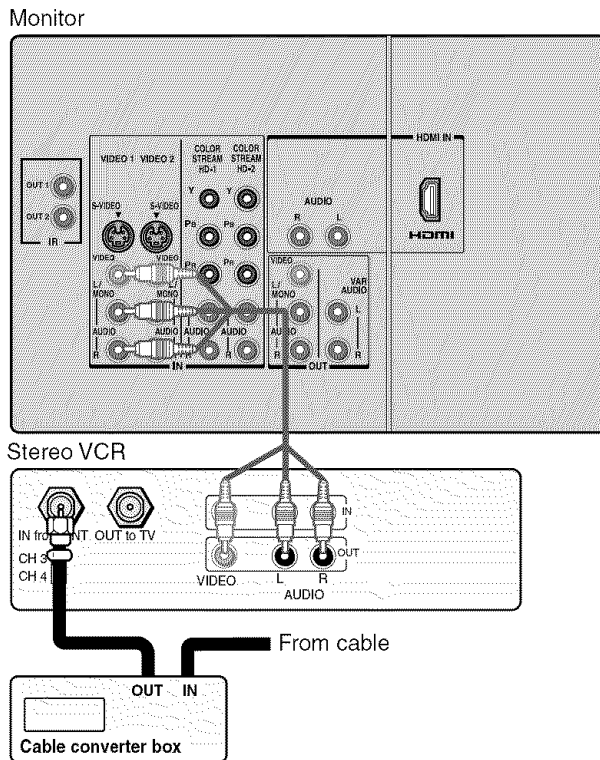

Note:

If you have a mono VCR, connect L/Mono to VCR Audio OUT using only one audio cable. If you have a VCR with S-video, use an S-video cable (in the S-video terminals) instead of a standard video cable. Do not connect a standard video cable and an S-video cable to Video-1 (or Video-2) at the same time, or the picture performance will be unacceptable.

The unauthorized recording, use, distribution, or revision of television programs, videotapes, DVDs, and other materials is prohibited under Copyright Law of the United States and other countries, and may subject you to civil and criminal liability.

Connecting a DVD player or satellite receiver and a VCR

This connection allows you to watch DVD/satellite and VCR.

You will need:

- one (or two, if satellite receiver is used) coaxial cable
- one set of standard A/V cables (between the monitor and VCR)
- one S-video cable (between the monitor and DVD player/satellite receiver)
- one pair of standard audio cables (between the monitor and DVD player/satellite receiver)

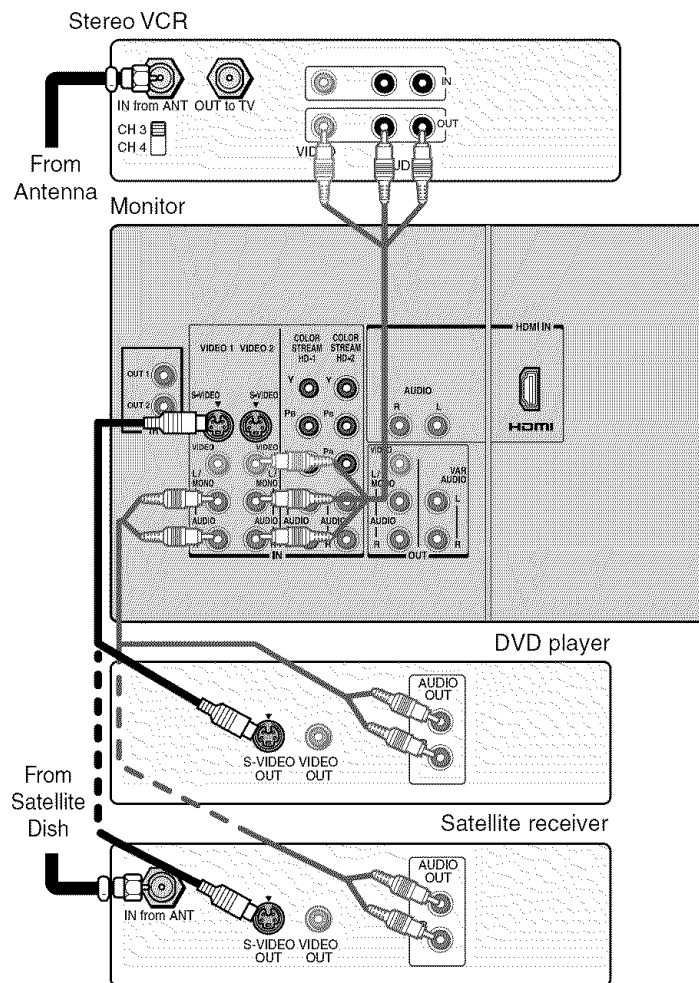

Note:

For the highest possible picture quality from a DVD player or satellite receiver without component video or HDMI, use an S-video cable. (If your DVD player has component video, see page 12. If your DVD player or satellite receiver has HDMI or DVI, see page 15.)

Do not connect both an S-video cable and a standard video cable between the monitor and DVD player/satellite receiver at the same time or the picture performance will be unacceptable.

Do not connect the DVD player/satellite receiver and VCR to the same set of Video inputs on the monitor. (See the illustrations, which show the DVD player/satellite receiver connected to Video-1 on the monitor, and the VCR connected to Video-2 on the monitor.)

The unauthorized recording, use, distribution, or revision of television programs, videotapes, DVDs, and other materials is prohibited under Copyright Law of the United States and other countries, and may subject you to civil and criminal liability.

Connecting a DVD player with ColorStream® (component video) and a VCR

This connection allows you to watch DVDs and video tapes. Your monitor has ColorStream (component video) inputs. Connecting your monitor to a DVD player with component video output (such as a Toshiba DVD player with ColorStream) can greatly enhance picture quality and realism.

You will need:

- one coaxial cable
- one set of standard A/V cables
- one pair of audio cables
- one set of component video cables (one S-video cable for a DVD player without component video inputs; see notes at right)

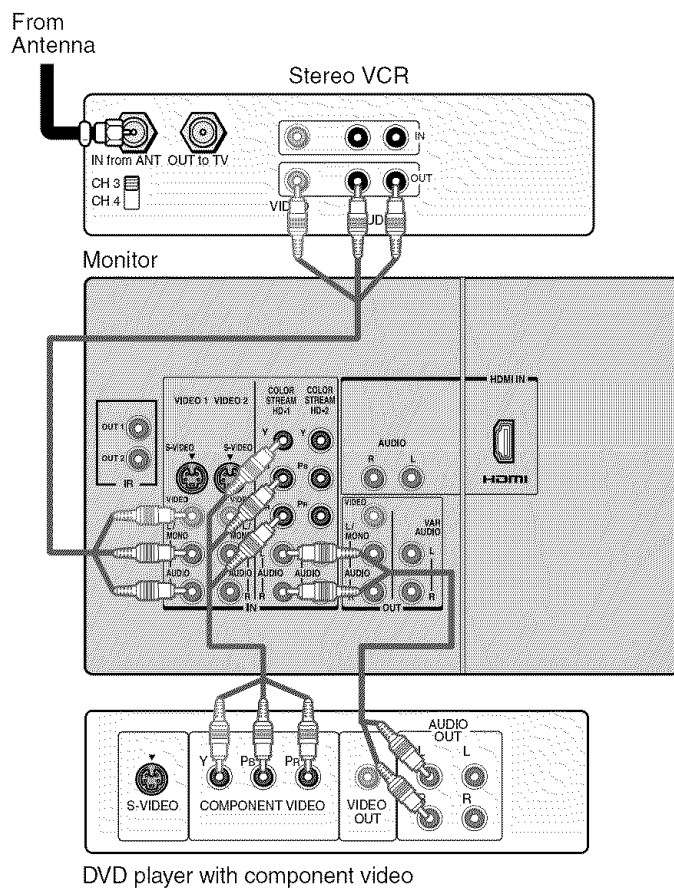

Note:

For the highest possible picture quality, use component video cables (or an HDMI cable) between the monitor and DVD player.

You can connect component video cables to either set of ColorStream terminals on the monitor (HD1 or HD2).

For HDMI or DVI connection, see page 15.

The ColorStream HD1/HD2 and HDMI terminals can be used with Progressive (480p, 720p) and Interlaced (480i, 1080i) scan systems; however, a 1080i signal will provide the best picture performance.

If your DVD player is not compatible with component video, HDMI, or DVI, use the S-video connections (plus the standard audio connections) instead (see page 11).

The unauthorized recording, use, distribution, or revision of television programs, videotapes, DVDs, and other materials is prohibited under Copyright Law of the United States and other countries, and may subject you to civil and criminal liability.

Connecting a DTV receiver/set-top box with ColorStream® (component video) and a VCR

This connection allows you to watch DTV (digital TV), VCR, and TV programs, and record DTV (composite video only) and TV programs.

Your monitor has ColorStream (component video) inputs. Connecting your monitor to a DTV receiver with component video inputs can greatly enhance picture quality and realism.

- To watch a DTV program, select ColorStream HD2 on the monitor.
- To record and watch the same TV program, tune the VCR to the channel to record, and select VIDEO 1 on the monitor.
- To record one program while watching another, tune the VCR to the channel to record, tune the DTV receiver to the channel to watch, and select ColorStream HD2 on the monitor.

You will need:

- two coaxial cables
- two sets of standard A/V cables
- one pair of audio cables
- one set of component video cables (one S-video cable for a DTV receiver without component video; see notes at right)

Note:

For the highest possible picture quality, use component video cables (or an HDMI cable) between the monitor and DTV receiver/set-top box.

You can connect component video cables to either set of ColorStream terminals on the monitor (HD1 or HD2).

For HDMI or DVI connection, see page 15.

The ColorStream HD1/HD2 and HDMI terminals can be used with Progressive (480p, 720p) and Interlaced (480i, 1080i) scan systems; however, a 1080i signal will provide the best picture performance.

If your DTV receiver or set-top box is not compatible with component video, HDMI, or DVI, use the S-video connections (plus the standard audio connections) instead (see page 11).

The unauthorized recording, use, distribution, or revision of television programs, videotapes, DVDs, and other materials is prohibited under Copyright Law of the United States and other countries, and may subject you to civil and criminal liability.

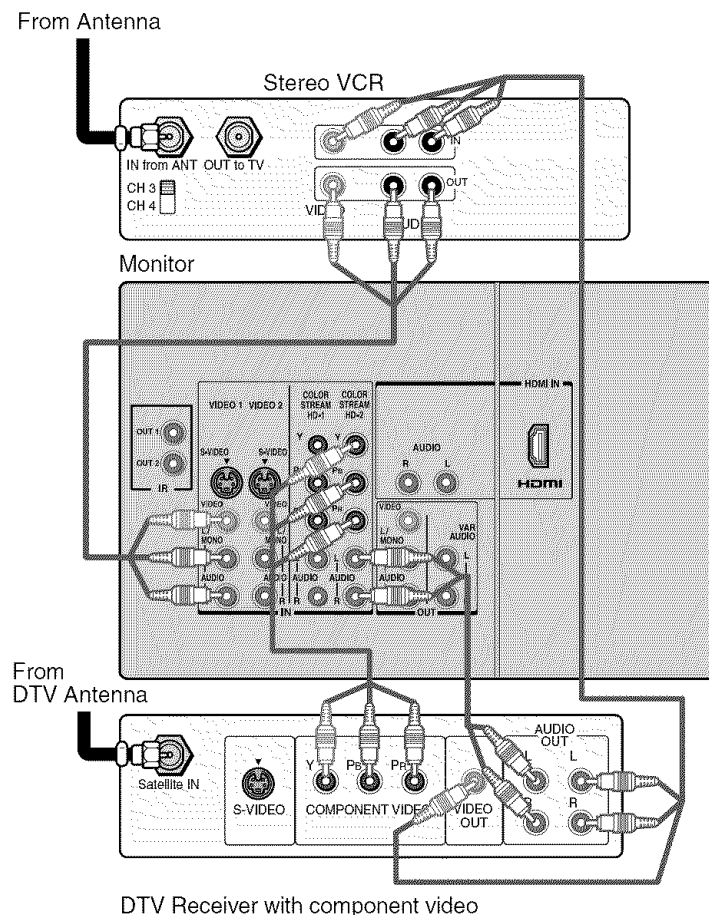

Connecting two VCRs

This connection allows you to record (dub/edit) from one VCR to another VCR while watching a videotape.

- To record one program while watching another, tune VCR1 to the channel to record, tune VCR2 to the channel to watch, and select VIDEO 2 on the monitor.

You will need:

- one signal splitter
- three coaxial cables
- three sets of standard A/V cables

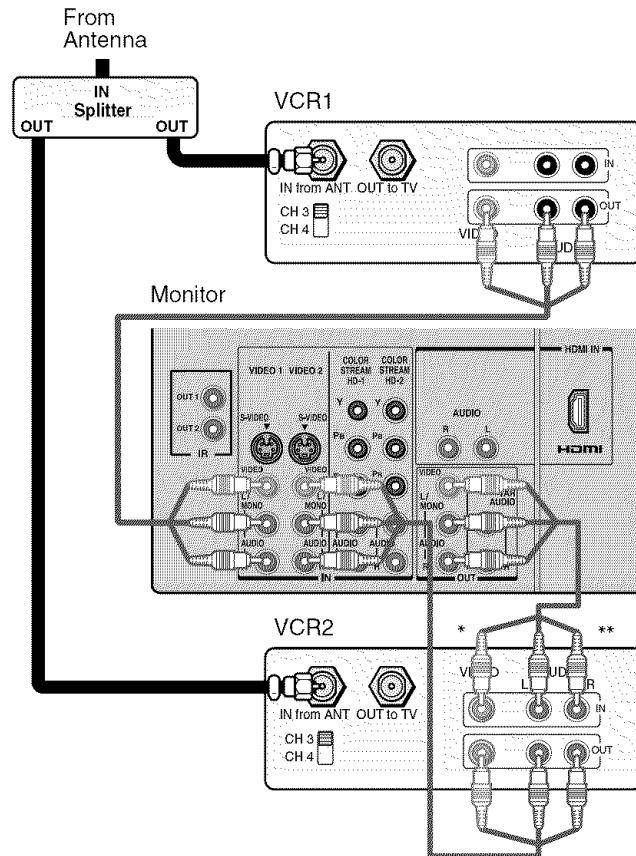

Note:

If you have VCR (VCR1) with S-video, use S-video cables instead of standard video cables for better picture performance. Do not connect both a standard video cable and an S-video cable to Video-1 (or Video-2) at the same time or the picture performance will be unacceptable.

Do not connect the same VCR to the output and input terminals is on the monitor at the same time. To dub or edit, VCR 2 must select Line IN, and the monitor must select VIDEO 1.

* The Video OUT terminal does not output the POP picture.

** The Audio OUT terminals can output the sound of either the Main or POP picture (see "Selecting the Audio OUT sound" on page 46).

The unauthorized recording, use, distribution, or revision of television programs, videotapes, DVDs, and other materials is prohibited under Copyright Law of the United States and other countries, and may subject you to civil and criminal liability.

Connecting a camcorder

This connection allows you to watch video materials recorded on a camcorder.

You will need:

- one set of standard A/V cables

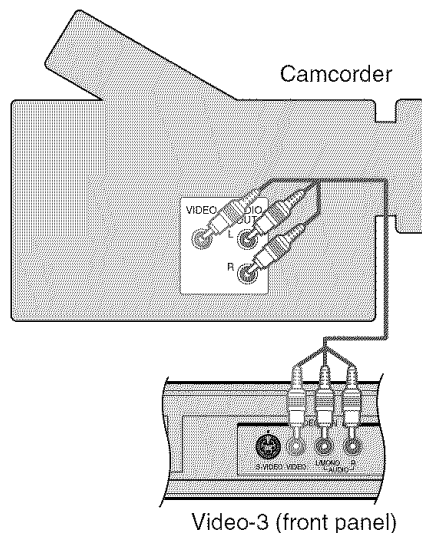

Note:

If you have a camcorder with S-video, use an S-video cable instead of a standard video cable for better picture performance. Do not connect both a standard video cable and an S-video cable at the same time or the picture performance will be unacceptable.

Connecting an HDMI™ or a DVI device to the HDMI input

The HDMI^[1] input on your monitor receives digital audio and uncompressed digital video from an HDMI device or uncompressed digital video from a DVI^[2] device.

This input is designed to accept HDCP^[3] program material in digital form from EIA/CEA-861/861B-compliant^[4] consumer electronic devices (such as a set-top box or DVD player with HDMI or DVI output).

The HDMI input is designed for best performance with 1080i high-definition video signals, but will also accept and display 480i, 480p, and 720p signals.



NOTE: NEVER CONNECT THIS MONITOR TO A PERSONAL COMPUTER (PC).

THIS MONITOR IS NOT INTENDED FOR USE WITH A PC.

To connect an HDMI device, you will need:

- one HDMI cable (type A connector)

For proper operation, it is recommended that you use a short HDMI cable. You should not encounter difficulty if you use an HDMI cable shorter than 16.4 ft (5m).

HDMI cable transfers both video and audio. Separate analog audio cables are not required (see illustration below). Some CDVs (video CDs) may not output digital audio signals. In that case, you may hear sound by connecting analog audio cables. However, if you connect analog audio cables with this connection, the HDMI terminal on the monitor will not receive the HDMI digital audio signal and you will hear analog audio only.

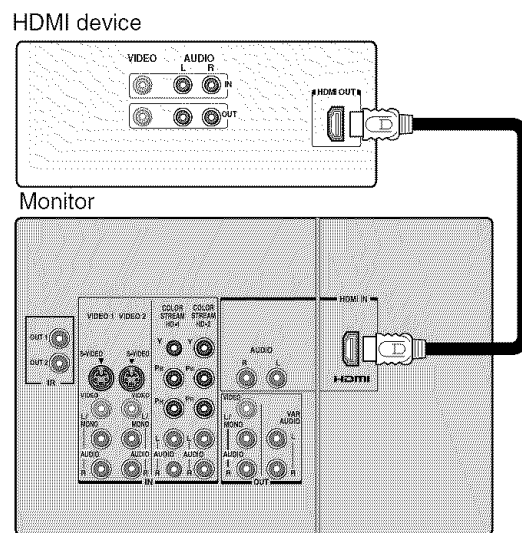

[1] HDMI = High-Definition Multimedia Interface.

[2] DVI = Digital Video Interface.

[3] HDCP = High-bandwidth Digital Content Protection.

[4] EIA/CEA-861/861B compliance covers the transmission of uncompressed digital video with high-bandwidth digital content protection, which is being standardized for reception of high-definition video signals. **Because this is an evolving technology, it is possible that some devices may not operate properly with the monitor.**

To ensure that the HDMI or DVI device is reset properly, it is recommended that you follow these procedures:

- When turning on your electronic components, **turn on the monitor first**, and then the HDMI or DVI device.
- When turning off your electronic components, **turn off the HDMI or DVI device first**, and then the monitor.

To connect a DVI device, you will need:

- one HDMI-to-DVI adapter cable (HDMI type A connector)

For proper operation, the length of the HDMI-to-DVI adapter cable should not exceed 9.8 ft (3m). The recommended length is 6.6 ft (2m).

- one pair of standard analog audio cables

An HDMI-to-DVI adapter cable transfers video only. Separate analog audio cables are required (see illustration below).

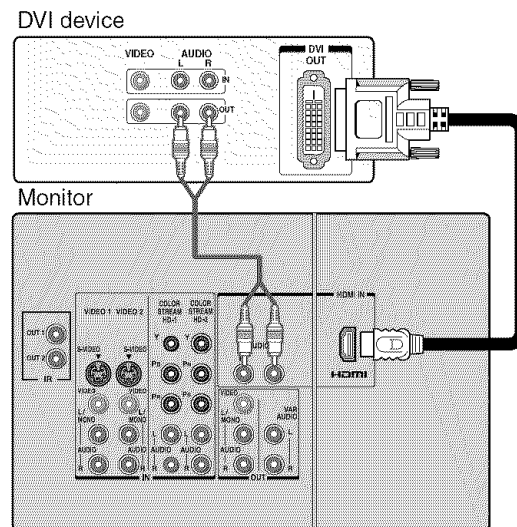

HDMI, the HDMI logo, and High-Definition Multimedia Interface are trademarks or registered trademarks of HDMI Licensing, LLC.

Controlling infrared remote-controlled devices through the monitor (IR pass-through)

You can use the monitor's IR OUT terminal (infrared pass-through) to remotely operate (through the monitor) many infrared remote-controlled devices (such as a Toshiba infrared remote-controlled VCR or DVD player) enclosed within an entertainment center or similar cabinet. Without the IR OUT connection, the device typically would need to be visible to operate it remotely.

You will need:

- one dual-wand IR blaster cable (included with your monitor)
- other audio/video cables as required to connect the device(s) to the monitor (see pages 8-15).

To connect the IR blaster cable:

1. Locate the infrared sensor on the front of your device. This sensor is marked on some devices.*
2. Align one of the IR blaster cable's wands about 1 inch away from the infrared sensor on the front of the device and attach it using the enclosed mounting tape. If you have a second device, attach the second wand in a similar manner (see illustration below).

Note: If you do not have a second device, coil the second wand with a rubber band and leave it behind the monitor.

3. Plug the IR blaster cable's plug into the monitor's IR OUT terminal.

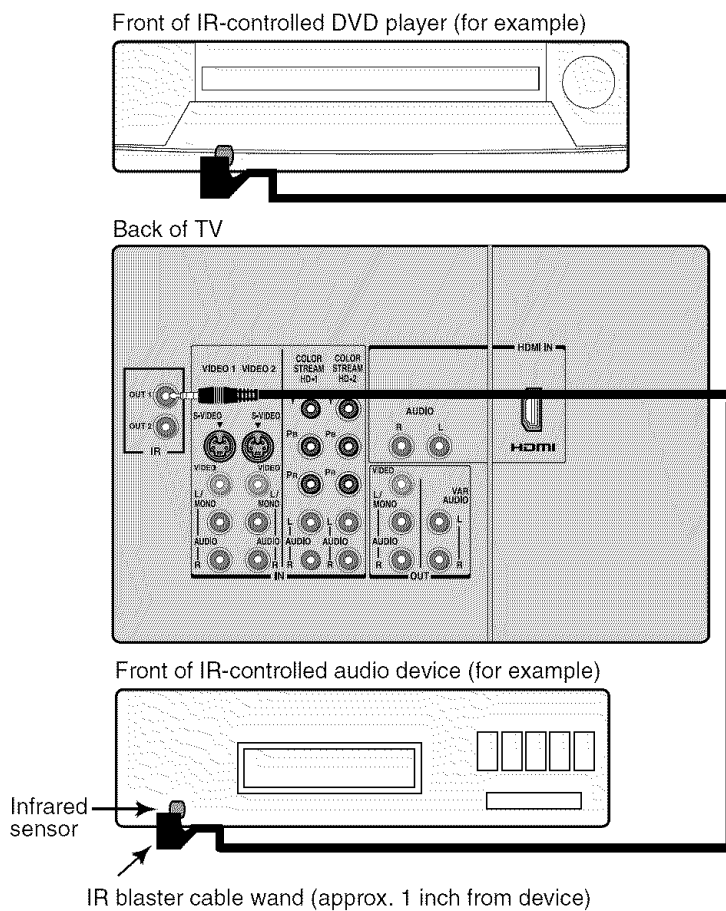

To control the device(s):

Point the monitor remote control (programmed to operate the device; see pages 22–23) or the device's remote control at the front of the monitor and press the button for the desired function. The signal passes from the remote control through the monitor to the device via the IR blaster cable.

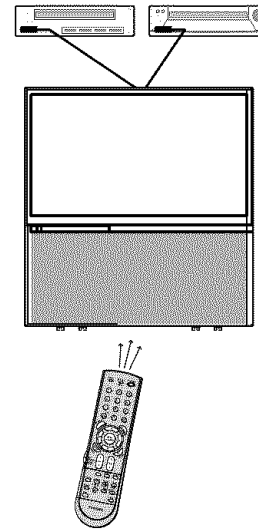

If you use the device's remote control to operate the device, you also will need to use the monitor's remote control to operate the monitor.

***If you cannot locate the device's infrared sensor:**

1. Turn OFF the device.
2. Starting at the lower left corner of the device, place the end of the device's remote control (with the infrared emitter) so it touches the front of the device and press POWER. (Do not use the monitor's remote control for this step.)
3. If the device turns on, the place that the remote control touched the device is the location of the sensor.
4. If the device does not turn on, move the remote control slightly to the right and press POWER again.
5. Repeat step 4 until you locate the device's infrared sensor.

Connecting an audio system

This connection allows you to use an audio amplifier and external speakers and adjust the audio level using the monitor's remote control.

To control the audio, turn on the monitor and the stereo amplifier, and turn off the built-in speakers (see "Turning off the built-in speakers" on page 45).

You will need:

- one pair of standard audio cables

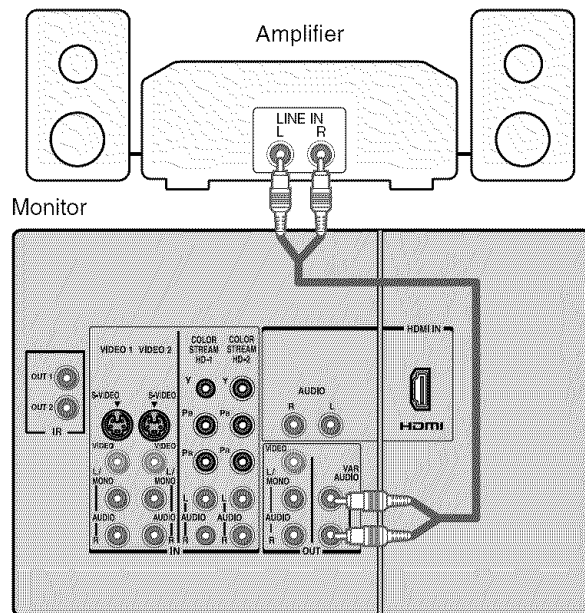

Note:

To hear sound when using an external audio amplifier, the volume of both the monitor and the amplifier must be set above 0 (zero).

For example, if the volume of the monitor is set to 0, you will not be able to hear any sound even if the volume of the amplifier is at its highest level.

Using the remote control

Preparing the remote control for use

Your monitor remote control can operate your monitor and most cable converter boxes, satellite receivers, VCRs, DVD players, and HTIBs (home theater in a box), even if they are different brands.

If you have a Toshiba device:

Your monitor remote control is preprogrammed to operate most Toshiba devices. See pages 20–21.

If you have a non-Toshiba device or a Toshiba device that the remote control is not preprogrammed to operate:

You can program the monitor remote control so it will operate the other device. See pages 20–23.

Installing the remote control batteries

1. Remove the battery cover from the back of the remote control.

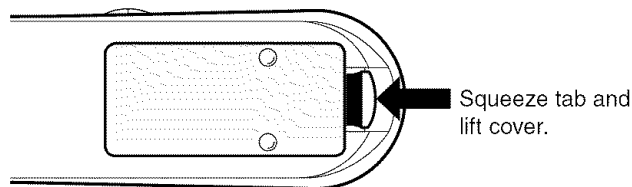

2. Install two “AA” size batteries, making sure to match the + and – signs on the batteries to the signs on the battery compartment.

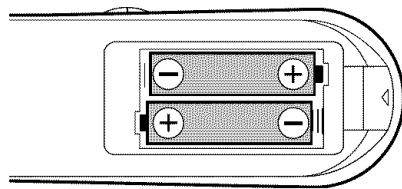

3. Reinsert the battery cover in the remote control until the tab snaps.

Remote control effective range

For optimum performance, aim the remote control directly at the monitor and make sure there is no obstruction between the remote control and the monitor.

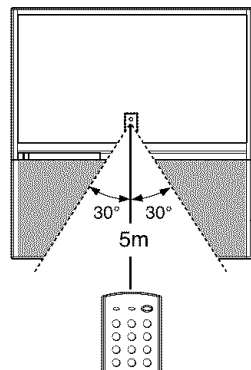

Note:

Your monitor's remote control may not operate certain features on your VCR or other electronic device.

Refer to the owner's manuals for your other devices to determine their available features. If your monitor's remote control does not operate a specific feature on a device, use the remote control that came with the device.

Caution:

- Never throw batteries into a fire.

Note:

- Be sure to use AA size batteries.
- Dispose of batteries in a designated disposal area.
- Batteries should always be disposed of with the environment in mind. Always dispose of batteries in accordance with applicable laws and regulations.
- If the remote control does not operate correctly, or if the operating range becomes reduced, replace batteries with new ones.
- When necessary to replace batteries in the remote control, always replace both batteries with new ones. Never mix battery types or use new and used batteries in combination.
- Always remove the batteries from the remote control if they are dead or if the remote control is not to be used for an extended period of time. This will prevent battery acid from leaking into the battery compartment.

Learning about the remote control

The buttons used for operating the monitor only are described here.

POWER turns the monitor on and off

RECALL displays monitor status information on-screen (page 47)

SLEEP sets the monitor to turn off at a specific time (page 42)

INPUT selects the video input source (page 40)

MUTE reduces or turns off the sound (page 43)

Device Switch switches among TV, CBL/SAT, VCR, and DVD modes (pages 20-23)
Set to "TV" to control the monitor.

Numbers (0-9, 100) enters the numbers directly

VOL (volume) ▲ ▼ adjusts the volume level

MENU accesses the on-screen system (page 24)

ENTER activates the function settings in the menu (page 24)

▲ ▼ ◀ ▶ (**arrows**) select or adjust items in the menus (page 24)

PIC SIZE cycles through the five picture sizes: Natural, TheaterWide 1, 2, 3, and Full (page 27)

EXIT closes on-screen menus (page 24)

SPLIT turns the POP feature on and off (page 31)

SOURCE selects the POP picture source (page 31)

FREEZE freezes the picture. Press again to restore the moving picture.

SWAP switches the main and POP pictures (page 32)

LIGHT illuminates the keypad for five seconds

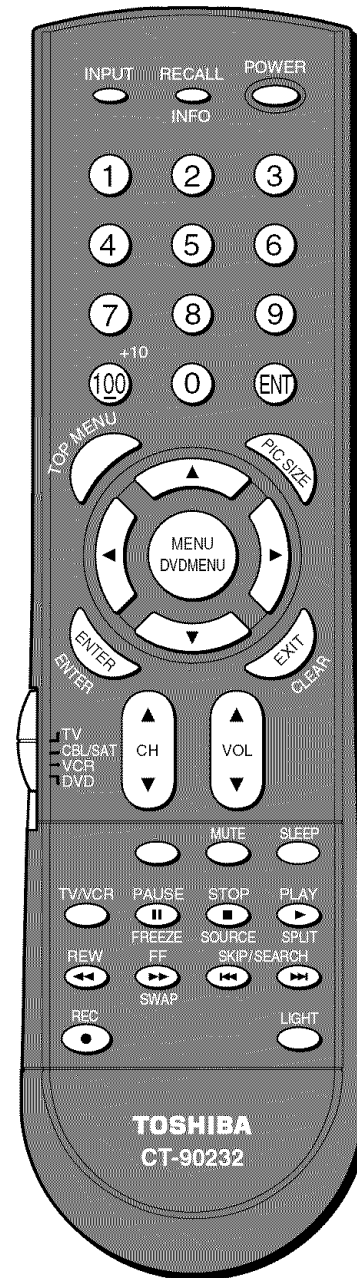

Note:

The error message "Not Available" will appear if you press a key for a function that is not available.

Using the remote control to operate your other devices

If you have a non-Toshiba device or a Toshiba device that the remote control is not preprogrammed to operate, you must first program the remote control to recognize the device (if you have not already done so). See pages 22 and 23.

To use your monitor remote control to operate a:

- Cable converter box or satellite receiver, set the **Device Switch** to “CBL/SAT”.
- VCR, set the **Device Switch** to “VCR”.
- DVD player or HTIB, set the **Device Switch** to “DVD”.

Note:

Even after the monitor remote control is programmed, it may not operate certain features on your other device. If this happens and you wish to use those features, you will need to use the device's original remote control.

Using the remote control

Point the remote control directly at the device.

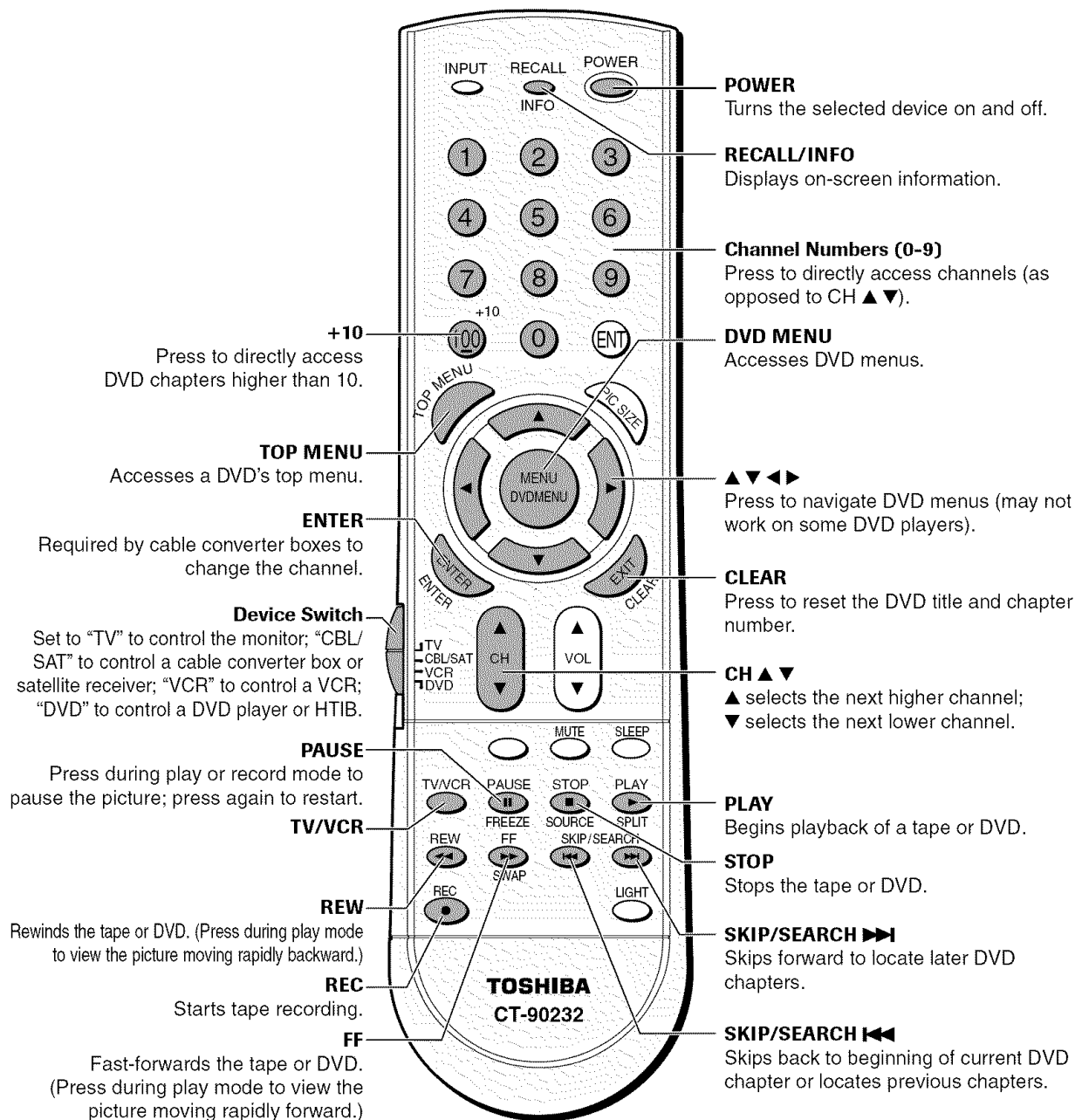

Remote control function key chart

Key Label	Monitor	Cable/Satellite	VCR	DVD
POWER	Power	Power	Power	Power
INPUT	Input	←	←	←
RECALL/INFO	On-screen display	INFO	---	On-screen display
1	Digit 1	Digit 1	Digit 1	Digit 1
2	Digit 2	Digit 2	Digit 2	Digit 2
3	Digit 3	Digit 3	Digit 3	Digit 3
4	Digit 4	Digit 4	Digit 4	Digit 4
5	Digit 5	Digit 5	Digit 5	Digit 5
6	Digit 6	Digit 6	Digit 6	Digit 6
7	Digit 7	Digit 7	Digit 7	Digit 7
8	Digit 8	Digit 8	Digit 8	Digit 8
9	Digit 9	Digit 9	Digit 9	Digit 9
0	Digit 0	Digit 0	Digit 0	Digit 0
100/-/+10	100	100/-	100	+10
ENT	---	---	---	---
TOP MENU	---	---	---	Top Menu
GUIDE/ PIC SIZE	Selects the image shape.	Guide	---	---
ENTER/ENTER	Enter	Select	---	Enter
CLEAR/EXIT	Exit	Exit	---	Clear
◀▶/▲▼	Menu select	Menu select	---	Menu select
VOL▲▼	Volume up/down	←	←	←
CH▲▼	---	Channel up/down	Channel up/down	---
SLEEP	Sleep timer	---	---	---
MUTE	Sound mute	←	←	←
PLAY/SPLIT	POP Split	---	Play	Play
STOP/SOURCE	POP Source	---	Stop	Stop
PAUSE/FREEZE	Still picture	---	Pause	Pause
TV/VCR	---	---	TV/VCR	---
SKIP/SEARCH	up/down	---	Search- +	Skip FWD/REV
FF/SWAP	POP Swap	---	Fast FWD	Fast FWD
REW	---	---	Rewind	Rewind
REC	---	---	Record	---
LIGHT	Lights the remote key.			

Note:

- "—" will send nothing.
- "←" same as left column.

Remote control codes (cont.)

Satellite receiver (cont.)

RCA: 008, 009, 013, 016
 Realistic: 030
 Samsung: 059
 Sony: 014, 055
 Star Choice: 057
 Star Trak: 025, 026, 037, 054
 STS: 024
 Toshiba: 000, 001, 002, 003, 004, 005, 006, 007, 020, 031, 056
 Uniden: 021, 028, 030, 032, 035, 039, 043, 045, 047, 058
 Zenith: 027

TV/VCR Combo

Action: 078
 GE: 059, 062
 Goldstar: 065
 Panasonic: 065
 Precision: 078
 Quasar: 065
 Realistic: 079
 Sony: 074
 Toshiba: 057
 Totevision: 009, 010, 065
 Zenith: 065

DVD/VCR Combo

Go Video:
 DVD=087, VCR=081
 JVC:
 DVD=088, VCR=082
 RCA:
 DVD=089, VCR=083
 Samsung:
 DVD=090, VCR=084
 Sanyo:
 DVD=091, VCR=085
 Zenith:
 DVD=092, VCR=086

DVD player

Aiwa: 006, 015
 Apex: 016, 017
 BOSE: 097
 Broksonic: 018
 Clarion: 019
 Classic: 020
 Daewoo: 021
 Denon: 022, 023, 024, 025
 Emerson: 026, 027
 Fisher: 028
 Funai: 027
 GE: 001, 029, 030
 Go Video: 087
 GPX: 031

Hitachi: 005, 032, 033, 034, 035
 JVC: 003, 007, 036, 042, 088
 Kenwood: 037
 Konka: 008, 009
 Magnavox: 004, 038
 Memorex: 039
 Mintek: 040
 NAD: 026
 Nakamichi: 041
 Norcent: 043
 Onkyo: 044
 Oritron: 058
 Panasonic: 010, 045, 046, 047, 048, 049, 050
 Philips: 004, 051
 Pioneer: 052, 053, 054, 055
 Proscan: 001, 056
 Qwestar: 057, 058
 RCA: 001, 002, 059, 089
 Sampo: 060
 Samsung: 061, 062, 086, 090
 Sansui: 073
 Sanyo: 063, 091
 Sharp: 064, 067
 Sherwood: 074
 Sony: 011, 012, 065, 066, 068, 069, 070
 Sylvania: 027
 Teac: 071
 Technics: 072
 Techwood: 075
 Toshiba: 000, 013, 076, 077, 078
 Yamaha: 079, 080, 081
 Zenith: 014, 082, 092

Portable DVD player

Aiwa: 093
 Audiovox: 094, 095
 Panasonic: 024, 096, 099
 RCA: 098

VCR

Admiral: 049
 Aiko: 019
 Aiwa: 018
 Akai: 003, 004, 037, 038, 039, 058, 069
 Audiovox: 010
 Bell & Howell: 007, 068
 Broksonic: 008, 017
 Calix: 010
 Carver: 026
 CCE: 019
 Citizen: 009, 010, 011, 012, 013, 014, 015, 019, 057, 073

Colortyme: 005
 Craig: 009, 010, 016, 061, 065, 079
 Curtis Mathes: 001, 005, 009, 012, 014, 040, 048, 053, 056, 057
 Daewoo: 011, 013, 015, 017, 018, 019, 057, 078
 Daytron: 078
 Denon: 063
 Dimensia: 001, 048
 Electrohome: 010, 020, 065
 Emerson: 003, 008, 010, 011, 017, 018, 020, 028, 039, 054, 057, 062, 065, 068, 072
 Fisher: 007, 016, 021, 022, 023, 057, 064, 068, 070, 071, 079
 Fuji: 004, 041
 Funai: 018, 073
 Garrard: 018
 GE: 001, 002, 009, 040, 042, 048, 056
 Go Video: 056, 059, 061, 081
 Goldstar: 005, 010, 014, 054, 056, 065, 067
 Gradiente: 018, 065
 Harman Kardon: 005
 Hitachi: 024, 025, 035, 037, 042, 063, 070, 080
 JBL: 076
 JC Penney: 005, 006, 007, 008, 009, 010, 023, 024, 025, 026, 035, 056, 061, 063, 065
 Jensen: 024, 025, 037, 050
 JVC: 005, 006, 007, 014, 037, 043, 062, 063, 068, 082
 Kenwood: 005, 006, 007, 012, 014, 037, 043, 053, 068, 071
 Kodak: 010
 LG: 010
 Lloyds: 053, 073, 079
 Logik: 061
 LXI: 010
 Magnasonic: 061, 065, 078
 Magnavox: 026, 027, 034, 044, 057, 061, 072
 Marantz: 005, 006, 007, 012, 014, 026, 053, 067

Memorex: 007, 009, 010, 016, 018, 034, 049, 063, 065, 066, 068, 075, 079
 MGA: 020, 028, 039
 MGN: 056
 Minolta: 024, 025, 035, 063
 Mitsubishi: 020, 024, 025, 028, 039, 043, 065
 Montgomery Ward: 049
 Motorola: 049
 MTC: 009, 046, 061
 Multitech: 009, 012, 018
 NEC: 005, 006, 007, 012, 014, 037, 043, 053, 054, 067, 070
 Nikko: 010
 Noblex: 009
 Optimus: 010, 049, 065
 Optonica: 031
 Orion: 054, 057, 062, 065, 068, 072
 Panasonic: 036, 045, 046, 057, 061, 072, 079
 Pentax: 012, 024, 025, 035, 042, 053, 063
 Pentax Research: 014
 Philco: 026, 027, 063
 Philips: 026, 031, 044, 057
 Pioneer: 006, 024, 043, 055
 Portland: 012, 013, 015
 Proscan: 001, 002, 048
 Proton: 061
 Quasar: 045
 Radio Shack: 010, 031, 065
 Radio Shack/Realistic: 007, 009, 010, 016, 018, 020, 021, 022, 031, 049
 Radix: 010
 RCA: 001, 002, 003, 009, 024, 025, 029, 035, 040, 042, 045, 048, 055, 056, 063, 071, 083
 Realistic: 007, 009, 010, 011, 016, 018, 020, 021, 022, 031, 049, 051, 056, 060, 065, 075, 079
 Ricoh: 047
 Runco: 034
 Samsung: 009, 011, 038, 056, 073, 084
 Sansui: 006, 037, 043, 061

Sanyo: 007, 009, 016, 054, 064, 068, 071, 075, 079, 085
 Scott: 008, 011, 017, 028, 030, 057, 065, 072
 Sears: 007, 010, 016, 021, 022, 023, 024, 025, 035, 053, 057, 063, 064, 065, 068, 071, 075, 079
 Sharp: 013, 020, 031, 049, 051, 060, 066
 Shintom: 004, 025, 032, 061
 Signature: 049
 Signature 2000: 075
 Singer: 047, 061
 Sony: 004, 032, 033, 041, 052, 058, 070, 074, 076, 077, 080
 STS: 035
 Sylvania: 018, 026, 027, 028, 044, 072
 Symphonic: 018, 051, 053, 073, 079
 Tandy: 007
 Tashiko: 010
 Tatung: 037
 Teac: 018, 029, 037
 Technics: 036
 Teknika: 010, 018, 065
 Toshiba: 000, 011, 021, 023, 024, 028, 030, 039, 057, 074, 078, 079
 Totevision: 009, 010, 065
 Unitec: 073
 Unitech: 009
 Vector Research: 005, 006, 011, 012, 053
 Video Concepts: 005, 006, 011, 012, 039, 053
 Wards: 009, 010, 011, 016, 018, 020, 024, 025, 031, 035, 049, 051, 056, 057, 060, 065, 066, 079
 White Westinghouse: 073
 XR-1000: 018
 Yamaha: 005, 006, 007, 014, 037, 053
 Zenith: 004, 032, 034, 041, 047, 069, 086

HTIB

Lasonic: 083
 Panasonic: 084
 Venturer: 085

Setting up your Monitor

Turning on the Monitor

Press POWER on the remote control or monitor. The Red LED indicator on the monitor will be illuminated. Press POWER again to turn off the Monitor.

Learning about the menu system

After you have installed the batteries and programmed the remote control, you will need to set some preferences on the monitor by using the menu system. You can access the menu system using the buttons on the monitor or remote control.

1. Press MENU to display the menu system.
 2. Press ◀ or ▶ to select a menu.
 3. Press ▲ or ▼ to select an item, then press ENTER.
 4. Press ▲ or ▼ to select or adjust a setting.
 5. Press ENTER to activate the settings or display the next menu.
 6. To close the menu, press EXIT.
- If you do not make a selection for a few seconds, the menu display will disappear automatically.

Monitor front panel

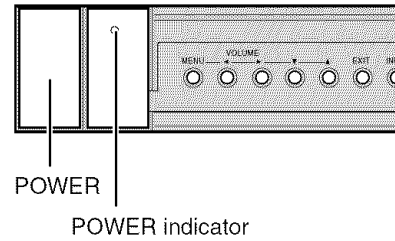

Monitor front panel

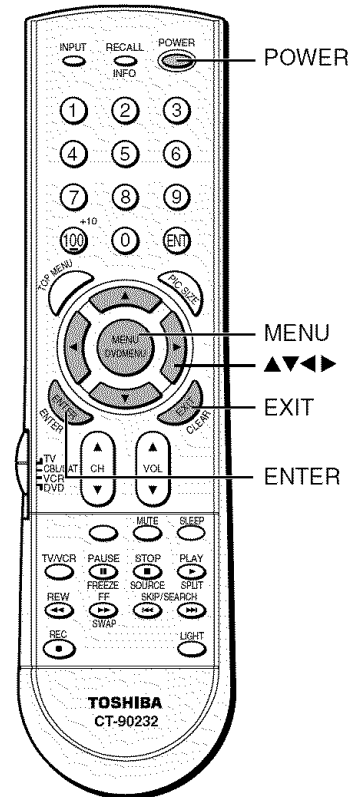
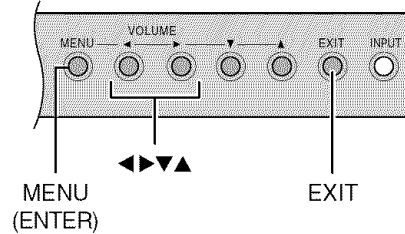

Note:
You can change the background of the menu. See page 46 for details.

Setting up your Monitor

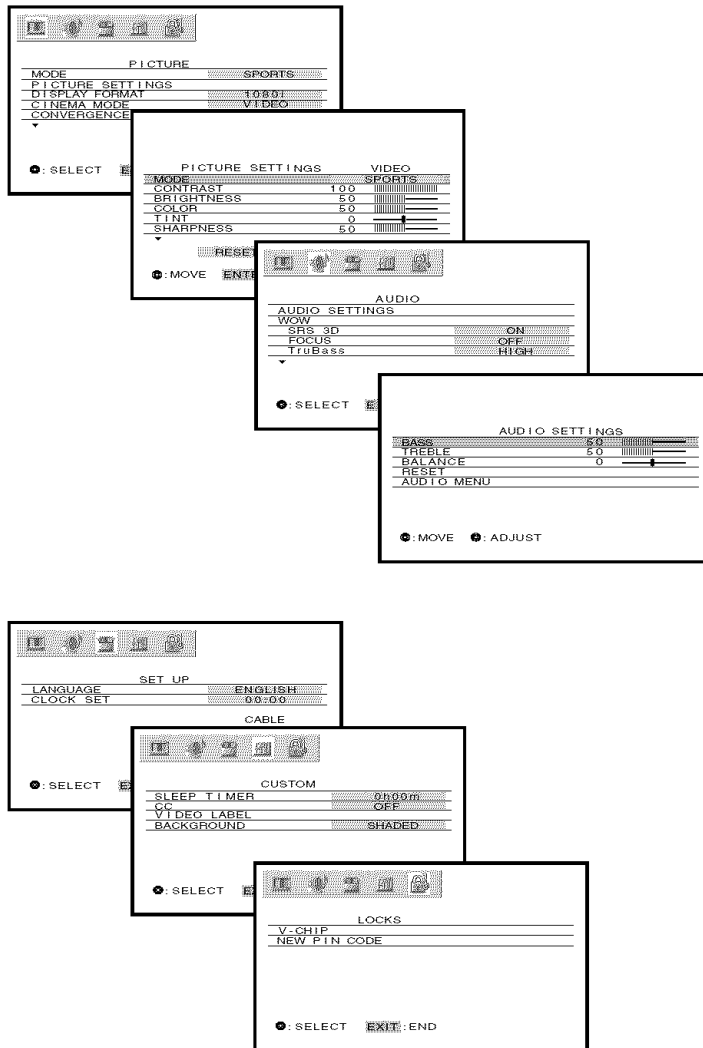

Changing the on-screen display language

You can choose from three different languages (English, French, and Spanish) for the on-screen display of adjustment menus and messages.

To select a language:

1. Press MENU, and then press ◀ or ▶ until the SET UP menu appears.
2. Press ▲ or ▼ to highlight LANGUAGE, and then press ENTER to display the pull-down menu.

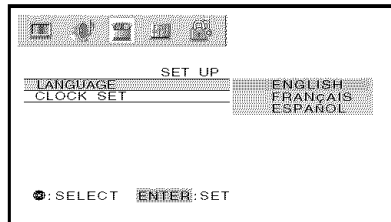

3. Press ▲ or ▼ to highlight your desired language.

Adjusting the color convergence

This projection monitor uses three separate picture tubes: red, green, and blue. The red, green, and blue images are projected onto the screen where they converge to form a full-color picture. You can see a clear picture only when the three images converge correctly. Convergence may drift over time or if you move the monitor. If you can see clear images on your monitor screen, skip this procedure.

It is recommended that the adjustment is made only after the monitor has been on for at least 30 minutes.

1. Press MENU, and then press ◀ or ▶ until the PICTURE menu appears.
2. Press ▲ or ▼ to highlight CONVERGENCE, and then press ENTER to display the pull-down menu.
3. Press ▲ or ▼ to highlight ADJUST, and then press ENTER. The monitor will enter 56-point convergence mode.

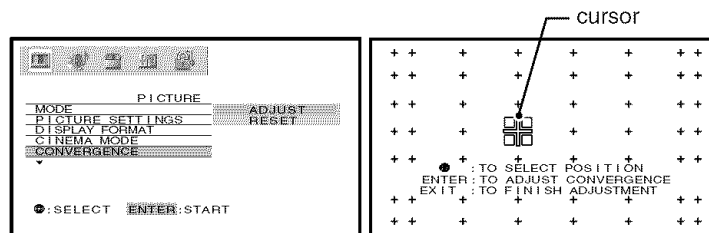

If you see separate red, blue, or green crossed lines (or red or blue shadows next to white lines), you need to adjust the convergence.

4. Press ▲▼◀▶ to move the cursor to the position you want to adjust.
5. Press ENTER repeatedly to select RED or BLUE adjusting mode (red crossed lines or blue crossed lines), depending on which color needs adjusting.

(continued on next page)

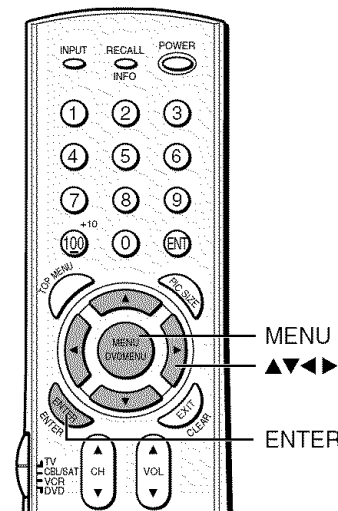
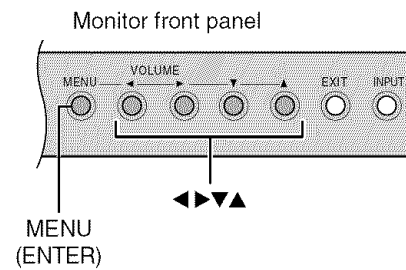

- Press ▲ (up), ▼ (down), ◀ (left), or ▶ (right) on the remote control to converge the red or blue line into the white line.

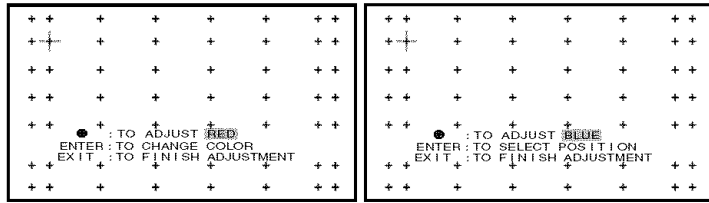

- If both red and blue need adjusting, you will need to perform steps 5 and 6 twice.
- Press ENTER to display the cursor.
- Repeat steps 4-8 to adjust another position.
- Press EXIT to close the convergence screen.

To reset your adjustments:

- Select RESET in step 3 on page 25, and then press ENTER. The message “WARNING: RESETS USER ADJUSTMENT TO FACTORY SETTINGS” will appear.
- Press ▲ or ▼ to highlight START, and then press ENTER. Your convergence settings have been reset.

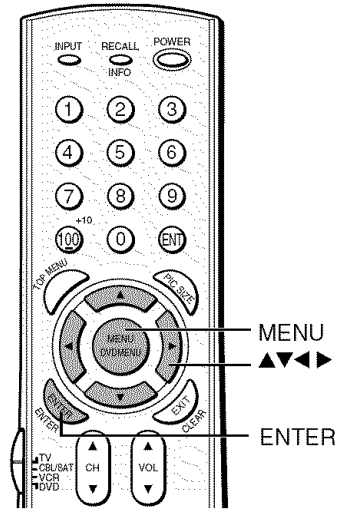
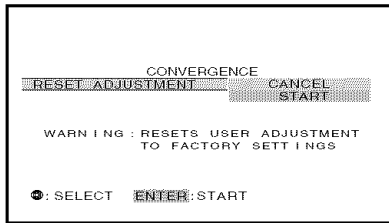

Setting up your Monitor

Operating your Monitor

Viewing the wide-screen picture formats (480i, 480p, and 1080i signals only)

You can view 480i, 480p, and 1080i format programs in a variety of picture sizes—Natural, TheaterWide 1, TheaterWide 2, TheaterWide 3, and Full. (The Full picture size is not selectable for 1080i format programs.)

The way the image displays in any of the picture sizes will vary depending on the format of the program you are viewing. Select the picture size that displays the current program the way that looks best to you. See “*Notice of possible adverse effects on monitor picture display,*” below right.

Selecting the picture size

1. Press PIC SIZE on the remote control.
2. Press the corresponding number button (0-4) or press ▲ or ▼ to select the desired picture size, as described below and on the next page.

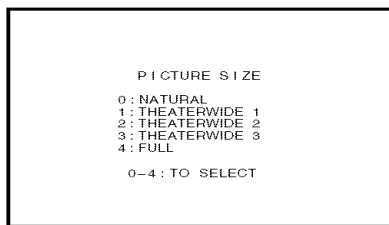

Natural picture size

Natural picture size example: The way the image displays will vary depending on the format of the program you are currently watching.

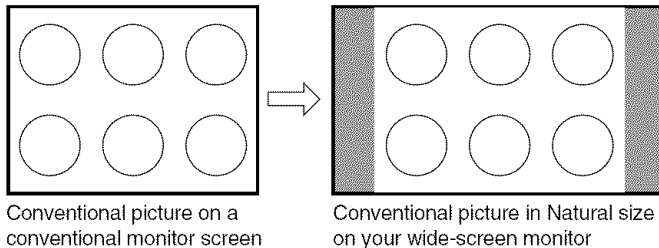

(continued on next page)

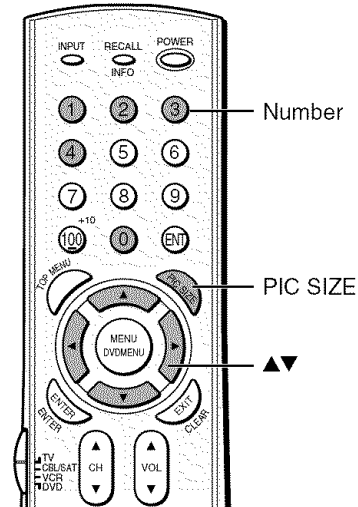

Note:

You also can change the picture size by selecting PICTURE SIZE in the PICTURE menu.

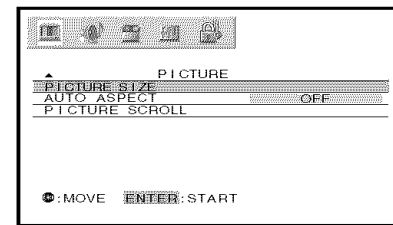

NOTICE OF POSSIBLE ADVERSE EFFECTS ON MONITOR PICTURE DISPLAY

Avoid displaying stationary images on your monitor screen for extended periods of time. Fixed (non-moving) patterns or images (including but not limited to PIP/POP windows, closed captions, video game patterns, TV station logos (from VCR, etc.), stock tickers, websites, and special formats that do not use the entire screen) can become permanently ingrained in the cathode ray tube(s) of the monitor and cause subtle but permanent ghost images. **This type of damage is NOT COVERED BY YOUR WARRANTY.** See item 33 on page 4 for details.

TheaterWide 1 picture size (For 4:3 format programs)

- The picture is non-uniformly enlarged—the center of the picture remains close to its original proportion, but the left and right edges are stretched wider to fill the screen.
- A small part of the picture at the top and bottom is hidden; however, this mode cannot be scrolled.

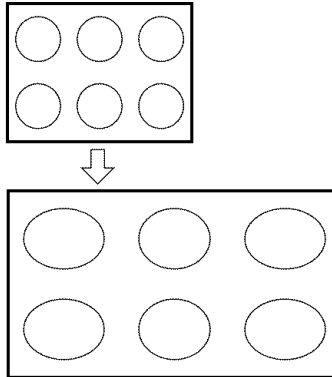

TheaterWide 1 picture size example

TheaterWide 2 picture size (For letter box programs)

- The entire picture is uniformly enlarged—it is stretched the same amount both wider and taller (retains its original proportion).
- Part of the picture at the top and bottom is hidden. To view the hidden areas, see “Scrolling the TheaterWide® picture” on page 29.

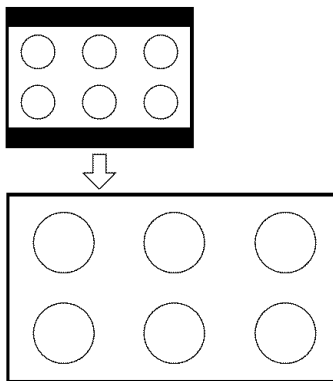

TheaterWide 2 picture size example

TheaterWide 3 picture size (For letter box programs with subtitles)

- The picture is non-uniformly enlarged—it is stretched wider to fill the width of the screen, but only slightly stretched taller.
- A small part of the picture at the top and bottom is hidden. To view the hidden areas (such as subtitles or captions), see “Scrolling the TheaterWide® picture” on page 29.

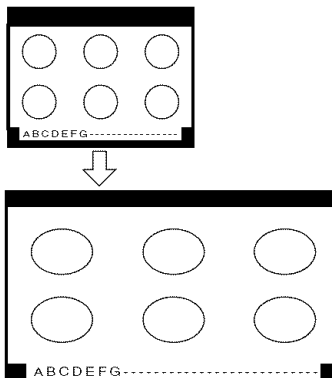

TheaterWide 3 picture size example

Full picture size (For 16:9 format programs)

- If you are receiving a 4:3 format program, the picture is stretched wider to fill the width of the screen, but not stretched taller.
- None of the picture is hidden.

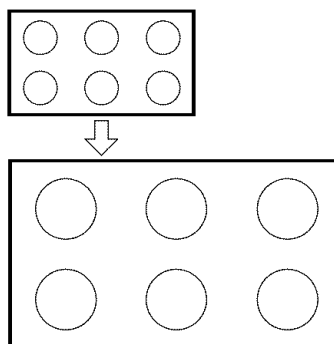

Full picture size example

Note:

- To select the picture size, press *PIC SIZE* on the remote control or select *PICTURE SIZE* in the *PICTURE* menu.
- The *PICTURE SIZE* feature is not available for some program formats (such as 720p). Such formats will display in *Natural* picture size (see page 27).
- If you select *TheaterWide 2* or *3*, the top and bottom edges of the picture may be hidden. To see the hidden edges, either scroll the picture (see page 29) or try viewing the program in *Full* picture size.

NOTICE OF POSSIBLE ADVERSE EFFECTS ON MONITOR PICTURE DISPLAY

Avoid displaying stationary images on your monitor screen for extended periods of time. Fixed (non-moving) patterns or images (including but not limited to PIP/POP windows, closed captions, video game patterns, TV station logos (from VCR, etc.), stock tickers, websites, and special formats that do not use the entire screen) can become permanently ingrained in the cathode ray tube(s) of the monitor and cause subtle but permanent ghost images. **This type of damage is NOT COVERED BY YOUR WARRANTY.** See item 33 on page 4 for details.

Note:

Using these functions to change the picture size (i.e., changing the height/width ratio) for any purpose other than your private viewing may be prohibited under Copyright Law of the United States and other countries, and may subject you to civil and criminal liability.

Scrolling the TheaterWide® picture (TheaterWide 2 and 3 only)

1. Press PIC SIZE to select the TheaterWide 2 or TheaterWide 3 mode.
2. Press MENU, and then press ◀ or ▶ until the PICTURE menu appears.
3. Press ▲ or ▼ to highlight PICTURE SCROLL.

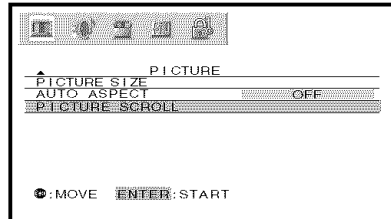

4. Press ENTER to display the Scroll Adjustment mode.

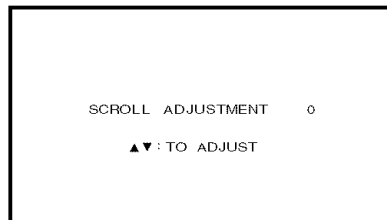

5. Press ▲ or ▼ to adjust the vertical position of the picture.
 - Normal (center) position

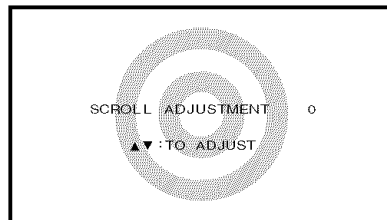

- To raise the picture, press ▲.

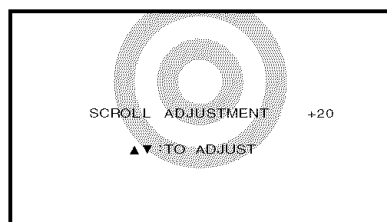

- To lower the picture, press ▼.

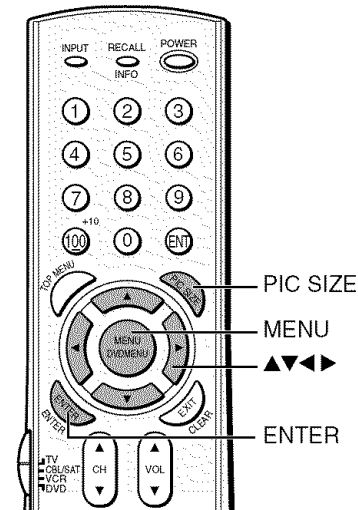
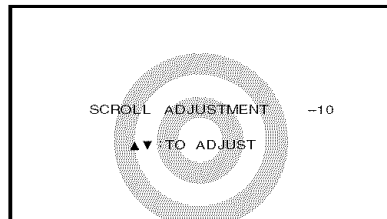

Note:

You can scroll the picture in TheaterWide 2 and TheaterWide 3 modes only. The scroll amounts are as follows:

- 480i/480p/1080i signal source:
 - TheaterWide 1 : Not adjustable
 - TheaterWide 2 : -10 to +20
 - TheaterWide 3 : -10 to +20

NOTICE OF POSSIBLE ADVERSE EFFECTS ON MONITOR PICTURE DISPLAY

Avoid displaying stationary images on your monitor screen for extended periods of time. Fixed (non-moving) patterns or images (including but not limited to PIP/POP windows, closed captions, video game patterns, TV station logos (from VCR, etc.), stock tickers, websites, and special formats that do not use the entire screen) can become permanently ingrained in the cathode ray tube(s) of the monitor and cause subtle but permanent ghost images. **This type of damage is NOT COVERED BY YOUR WARRANTY.** See item 33 on page 4 for details.

Using the AUTO ASPECT feature

When the AUTO ASPECT feature is set to ON and the monitor receives a 480i signal (other than an HDMI input source), the picture size is automatically selected (as described in the following table).

Aspect ratio of signal source	Automatic aspect size (automatically selected when AUTO ASPECT is ON)
4:3 Normal	Natural
16:9 Full	Full
4:3 Letter box	TheaterWide 2
Not defined (no ID-1 data)	User-set mode

If the signal does not include aspect information, the picture size you selected on pages 27–28 is displayed.

To turn on the AUTO ASPECT feature:

1. Press MENU, and then press ◀ or ▶ until the PICTURE menu appears.

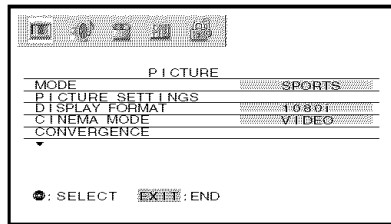

2. Press ▲ or ▼ to highlight AUTO ASPECT, and then press ENTER.

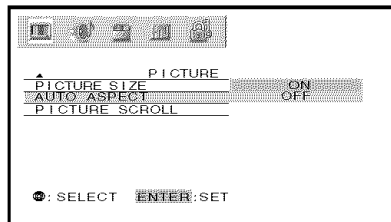

3. Press ▲ or ▼ to select ON, and then press ENTER.

Note:

The AUTO ASPECT feature is available for additional formats when viewing HDMI sources because AUTO ASPECT operates based on information found in the digital HDMI signal (not ID-1 data).

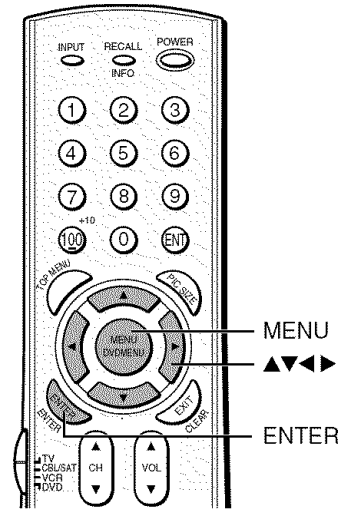

NOTICE OF POSSIBLE ADVERSE EFFECTS ON MONITOR PICTURE DISPLAY

Avoid displaying stationary images on your monitor screen for extended periods of time. Fixed (non-moving) patterns or images (including but not limited to PIP/POP windows, closed captions, video game patterns, TV station logos (from VCR, etc.), stock tickers, websites, and special formats that do not use the entire screen) can become permanently ingrained in the cathode ray tube(s) of the monitor and cause subtle but permanent ghost images. **This type of damage is NOT COVERED BY YOUR WARRANTY.** See item 33 on page 4 for details.

Using the POP double-window feature

The POP (picture-out-picture) feature splits the screen into a double window that allows you to watch two external input sources (for example, a VCR and DVD player) at the same time.

To display a picture from an external source in the POP window:

1. Connect the external source equipment (see “Connecting your Monitor” on page 8).
2. Press INPUT to select the external input source you want to watch in the main window.
3. Press SPLIT to display the POP window.

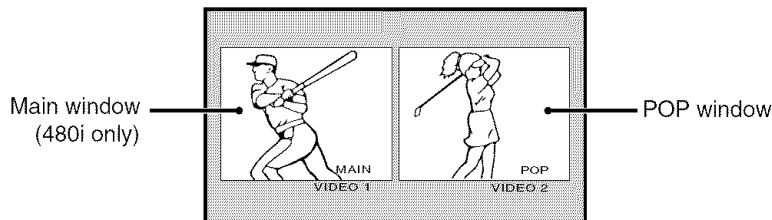

4. Repeatedly press SOURCE to select the input source for the POP window (VIDEO 1, VIDEO 2, VIDEO 3, ColorStream® HD1, ColorStream® HD2, or HDMI). The current source will display in purple.
5. You can play a tape as the POP picture, or select a channel for the POP window using the VCR's remote control.

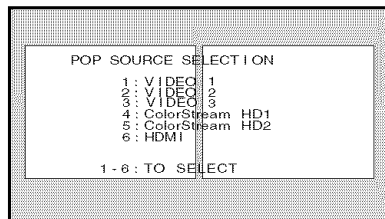

While the above menu is on the screen, you can select the desired input source by pressing the corresponding number button (1-6). If the V-CHIP feature is active and you try to watch an input source that exceeds your set rating limits, the program will be blocked (see “Using the V-CHIP menu” on page 33).

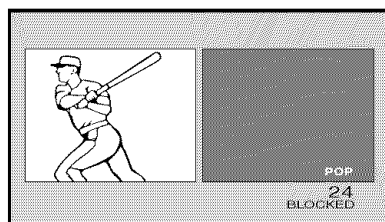

To close the POP window:
Press SPLIT again or EXIT.

Note:

- You can display only 480i format programs in the Main window.
- You can choose to output the sound of either the main or POP program through the AUDIO OUT terminals (see “Selecting the Audio OUT sound” on page 46).
- You can choose to hear the main or POP audio through the monitor speakers (See “Switching the speaker audio (main or POP program)” on page 32).
- HDMI, 720p ColorStream, 480p ColorStream, and 1080i ColorStream signals will only display in the POP (right) window. These signals will not display in the main (left) window when the monitor is in double-window mode.
- If an HDMI or ColorStream source is being viewed when you open the POP double-window feature, the HDMI or ColorStream source will default to the POP (right) window.

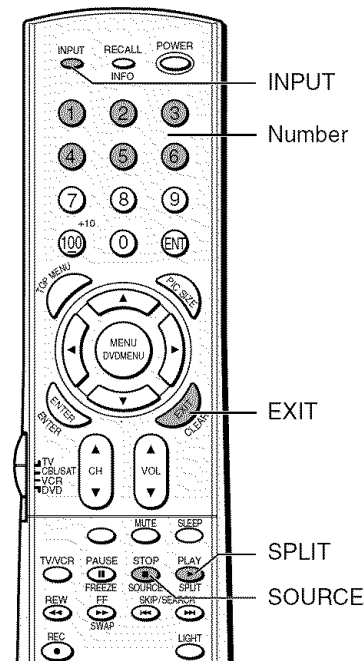

NOTICE OF POSSIBLE ADVERSE EFFECTS ON MONITOR PICTURE DISPLAY

Avoid displaying stationary images on your monitor screen for extended periods of time. Fixed (non-moving) patterns or images (including but not limited to PIP/POP windows, closed captions, video game patterns, TV station logos (from VCR, etc.), stock tickers, websites, and special formats that do not use the entire screen) can become permanently ingrained in the cathode ray tube(s) of the monitor and cause subtle but permanent ghost images. **This type of damage is NOT COVERED BY YOUR WARRANTY.** See item 33 on page 4 for details.

Swapping the main and POP pictures

Press SWAP while you are using the POP feature to swap the position of the main and POP pictures.

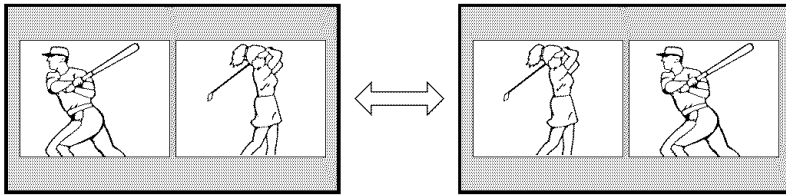

Switching the speaker sound (main or POP program)

Press ◀ or ▶ while you are using the POP feature to switch the sound (main or POP) from the speakers. The POP sound is monaural only. The selected input source indicator is displayed in purple.

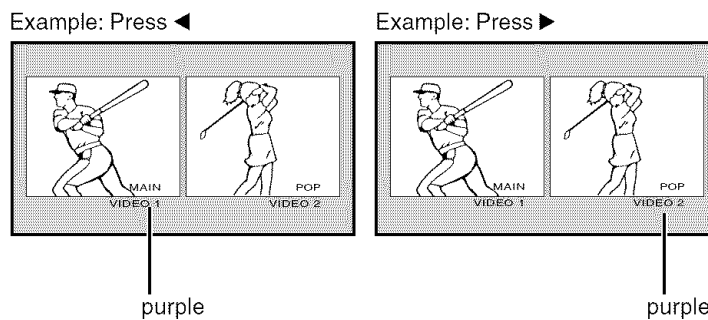

Double-Window aspect ratio

The Double-Window feature displays each picture according to its input signal aspect ratio, as illustrated below.

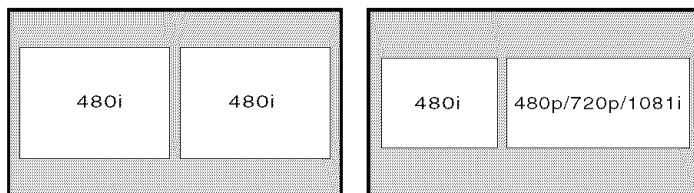

Note:

- If the POP program is not 480i format, it will not display in the main window when you press SWAP.
- The VARIABLE AUDIO OUT terminals will switch with the speaker sound. However, the source of the regular AUDIO OUT terminals is determined by the AUDIO OUT menu setting (page 46). The regular AUDIO OUT terminals do not switch with the speaker sound.

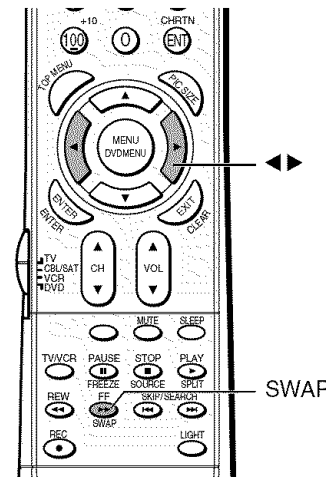

Note:

- The AUTO ASPECT feature (page 30) does not operate in double-window mode.
- Aspect ratio is the ratio of width to height of the picture.

NOTICE OF POSSIBLE ADVERSE EFFECTS ON MONITOR PICTURE DISPLAY

Avoid displaying stationary images on your monitor screen for extended periods of time. Fixed (non-moving) patterns or images (including but not limited to PIP/POP windows, closed captions, video game patterns, TV station logos (from VCR, etc.), stock tickers, websites, and special formats that do not use the entire screen) can become permanently ingrained in the cathode ray tube(s) of the monitor and cause subtle but permanent ghost images. **This type of damage is NOT COVERED BY YOUR WARRANTY.** See item 33 on page 4 for details.

Using the LOCKS menu

The LOCKS menu includes the V-Chip and New PIN Code functions. You can use these functions after entering the correct PIN code.

Entering the PIN code

1. Press MENU, and then press ◀ or ▶ until the LOCKS menu appears.

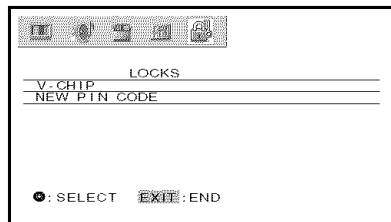

2. Press ▲ or ▼ to display the PIN code entering mode.

- Blocking Reset status: Set your 4-digit code by pressing the Number buttons (0-9).
- When the PIN code is already stored: Press the Number buttons (0-9) to enter the 4-digit PIN code used for blocking channels.

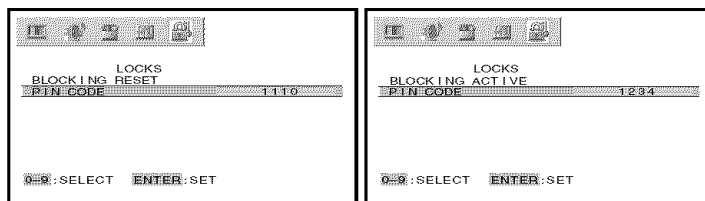

If the wrong PIN code is entered, the message "Incorrect" appears. Enter the code again, and then press ENTER.

If you cannot remember your PIN code

1. While the PIN code entering screen is displayed, press RECALL four times within five seconds. The PIN code will be released (Blocking Reset status restored).
2. Enter a new 4-digit code, and then press ENTER. The LOCKS menu appears.

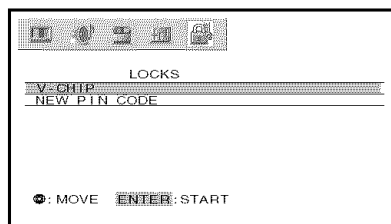

Using the V-CHIP menu

Some movies and TV programs include signals that classify the content of the program (violence, sex, dialog, language). The V-CHIP control feature in this monitor detects the signals and blocks the programs according to your selections. To use this feature, perform the following setup.

(continued on next page)

Note:

The V-Chip function is available only for the U.S. V-Chip system. The Canadian V-Chip system is not supported.

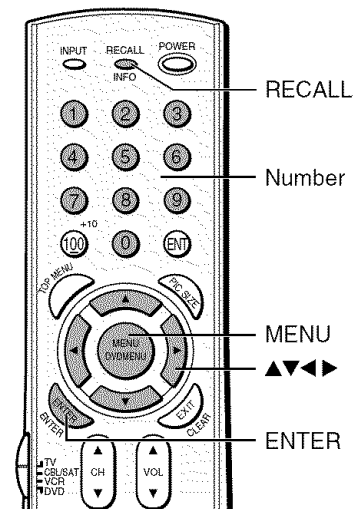

ENABLE BLOCKING

1. From the LOCKS menu (page 33), press ▼ or ▲ to highlight V-CHIP, and then press ENTER.

The V-CHIP menu appears.

2. Press ▼ or ▲ to highlight ENABLE BLOCKING, and then press ENTER.

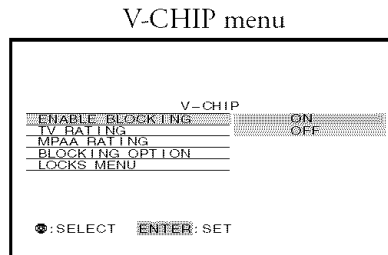

3. Press ▲ or ▼ to select ON or OFF.
ON : To enable your setting (Lock)
OFF: To release your setting (Unlock)

TV RATING (Independent rating system for broadcasters)

1. From the V-CHIP menu, press ▼ or ▲ to highlight TV RATING, and then press ENTER.

The TV RATING menu appears.

2. Press ▼ or ▲ to select an item.
3. Press ► to lock (displays "X")
Press ◀ to unlock (displays "✓")
4. Repeat steps 2 and 3 to set the next item.

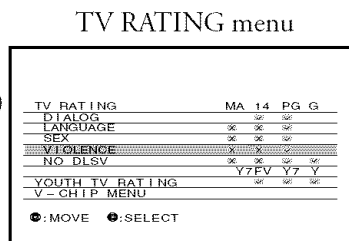

The TV age-based ratings and content themes you can lock are listed in the table below.

Ratings	Description and Content themes
MA	Mature Audience Only (This program is specifically designed to be viewed by adults and therefore may be unsuitable for children under 17.) L) Crude or indecent language S) Explicit sexual activity V) Graphic violence
14	Parents Strongly Cautioned (This program contains some material that many parents would find unsuitable for children under 14 years of age.) D) Intensely suggestive dialog L) Strong, coarse language S) Intense sexual situations V) Intense violence
PG	Parental Guidance Suggested (This program contains material that parents may find unsuitable for younger children.) D) Some suggestive dialog L) Infrequent coarse language S) Some sexual situations V) Moderate violence
G	General Audience (Most parents would find this program suitable for all ages.)
Y7, Y7FV	Directed to Older Children (This program is designed for children age 7 and above. Note: Programs in which fantasy violence may be more intense or more combative than other programs in this category are designated Y7FV.)
Y	All Children (This program is designed to be appropriate for all children.)

LOCKS menu

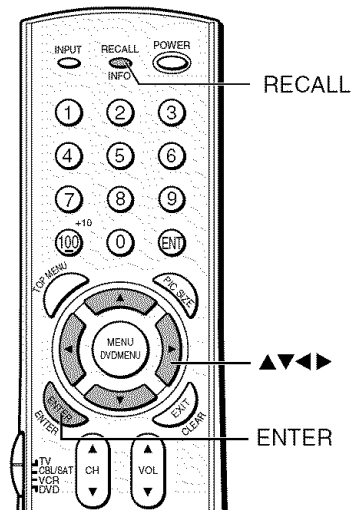
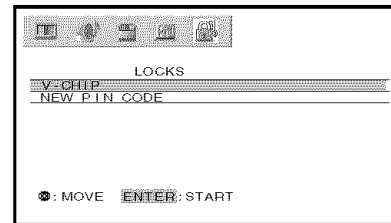

Press RECALL to display the rating of the TV program you are currently watching.

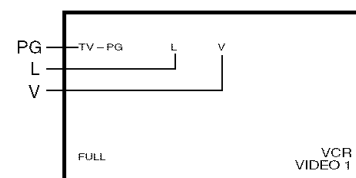

MPAA RATING (Independent rating system for movies)

- From the V-CHIP menu (page 34), press ▼ or ▲ to highlight MPAA RATING, and then press ENTER. The MPAA RATING menu appears.
- Press ▲ or ▼ to highlight MPAA RATING.
- Press ► to lock ("X") or press ◀ to unlock ("✓").

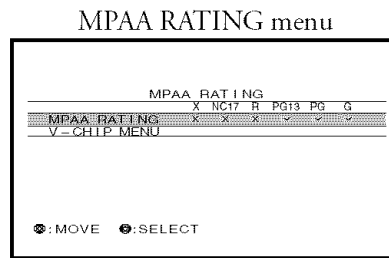

V-CHIP menu

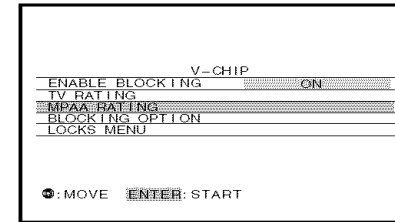

The movie ratings you can lock are described as follows:

- X : X-rated (For adults only)
- NC17: Not intended for anyone 17 and under
- R : Restricted (Under 17 requires accompanying parent or adult guardian.)
- PG13 : Parents Strongly Cautioned (Some material may be inappropriate for children under 13)
- PG : Parental Guidance Suggested (Some material may not be suitable for children)
- G : General Audience (Appropriate for all ages)

BLOCKING OPTION

- From the V-CHIP menu (page 34), press ▼ or ▲ to highlight BLOCKING OPTION, and then press ENTER. The BLOCKING OPTION menu appears.
- Press ▲ or ▼ to select an item, as described below:

MPAA UNRATED:

- Highlight MPAA UNRATED, and then press ENTER.
- Press ▲ or ▼ to select ON (Lock) or OFF (Unlock) for unrated programs in the MPAA rating system, then press ENTER.

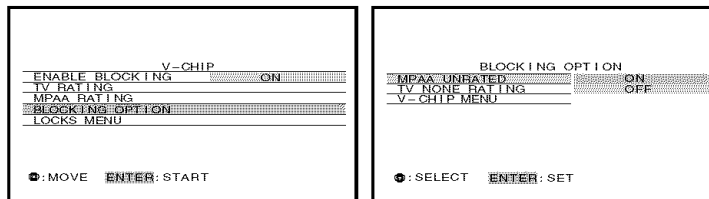

TV NONE RATING:

- Highlight TV NONE RATING, and then press ENTER.
- Press ▲ or ▼ to select ON (Lock) or OFF (Unlock) for programs rated NONE in the TV PARENTAL GUIDELINES, then press ENTER.

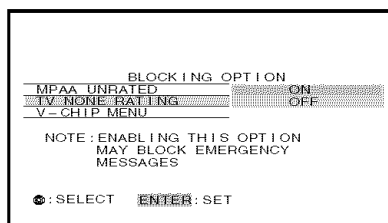

V-CHIP MENU:

Highlight V-CHIP menu, then press ENTER to return to the V-CHIP menu.

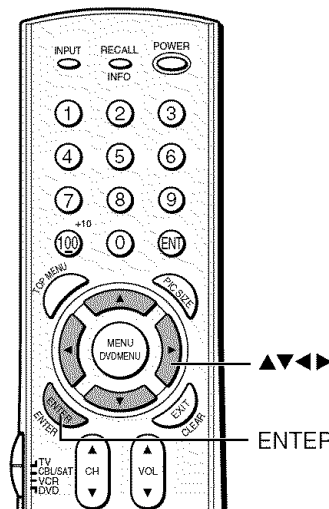

Caution:

Be aware that setting the TV None Rating to ON may block the broadcast of emergency information. The menu will display the note, "Enabling this option may block emergency messages" to warn you of this possibility.

Changing the PIN code

1. From the LOCKS menu (page 33), press ▲ or ▼ to highlight NEW PIN CODE.
2. Press the Number buttons (0-9) to enter a new 4-digit code. The numbers you enter will replace the dashes in the display.

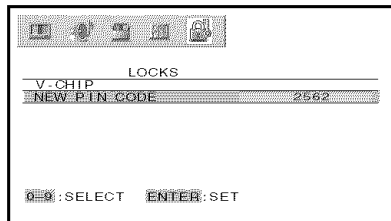

3. Press ENTER. The new PIN code is now active.

Adjusting the picture

Selecting the picture mode

You can select your desired picture type from four picture modes: Sports, Standard, Movie, and Preference.

Mode	Picture Quality
Sports	Bright and dynamic picture (factory setting)
Standard	Standard picture setting (factory setting)
Movie	Movie-like picture setting (factory setting)
Preference	Your personal preference*

*(see "Saving your new preferences" on page 37.)

To select the picture mode:

1. Press MENU, and then press ◀ or ▶ until the PICTURE menu appears.
2. Press ▼ or ▲ to highlight MODE, and then press ENTER.
3. Press ▼ or ▲ to select the mode you prefer, then press ENTER.

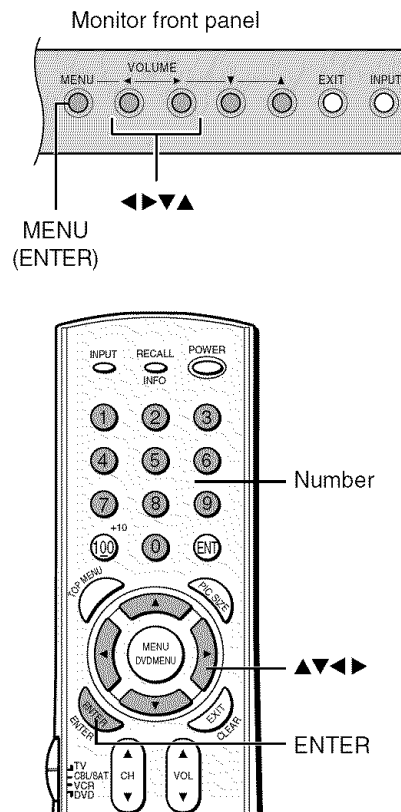
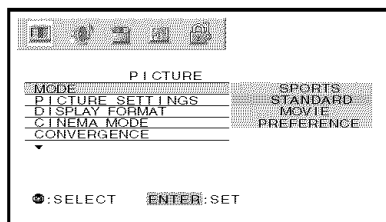

Note:

If you select one of the factory-set picture modes (SPORTS, STANDARD, or MOVIE) and then change a picture quality setting (for example, increase the contrast), the picture mode automatically changes to PREFERENCE in the Picture menu.

To save your new picture quality settings, you must select SAVE (see page 37) before closing the Picture menu or the monitor will return to the previous picture mode.

Adjusting the picture quality

You can adjust the picture quality to your personal preferences, including the contrast, brightness, color, tint, sharpness, and color temperature.

Selection	Pressing	
contrast	lower	higher
brightness	darker	lighter
color	paler	deeper
tint	reddish	greenish
sharpness	softer	sharper
color temperature	cool	medium warm

To adjust the picture quality:

1. Press MENU, and then press ◀ or ▶ until the PICTURE menu appears.
2. Press ▼ or ▲ to highlight PICTURE SETTINGS, then press ENTER.
The PICTURE SETTINGS menu appears.
3. Press ▲ or ▼ until the item you want to adjust is highlighted, then press ENTER.
4. Press ◀ or ▶ to adjust the level.

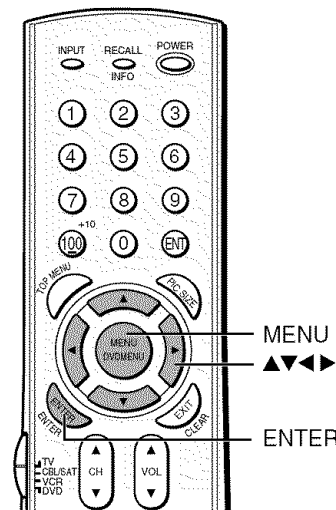
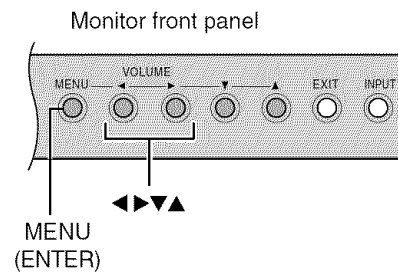
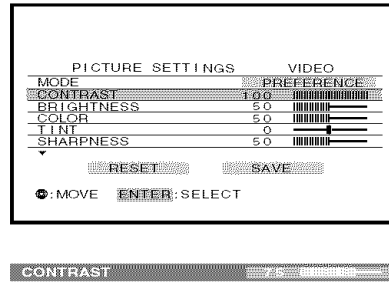

The PICTURE settings you adjusted can be saved in the PICTURE SETTINGS menu's PREFERENCE mode.

You can select your settings (PREFERENCE mode) or choose one of the factory-set modes, as described on page 36.

Saving your new preferences

You can save the PICTURE settings you adjusted (contrast, brightness, color, tint, sharpness, color temperature and CableClear DNR) in the PICTURE SETTINGS menu's PREFERENCE mode.

To save your new preferences:

1. Press MENU, and then press ◀ or ▶ until the PICTURE menu appears.
2. Press ▲ or ▼ to highlight PICTURE SETTINGS, and then press ENTER.
The PICTURE SETTINGS menu appears.
3. Press ▲▼◀▶ to highlight SAVE, and then press ENTER.

When complete, "SAVE" changes to "DONE" in the menu and the picture mode automatically changes to PREFERENCE (see "Selecting the picture mode" on page 36).

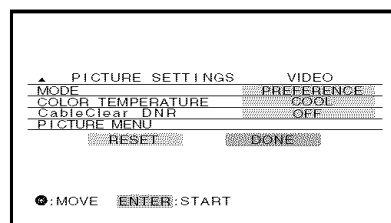

Selecting the color temperature

You can change the quality of the picture by selecting from three preset color temperatures: cool, medium, and warm.

To select the color temperature:

Mode	Picture Quality
cool	bluish
medium	neutral
warm	reddish

1. Press MENU, and then press ◀ or ▶ until the PICTURE menu appears.
2. Press ▲ or ▼ to highlight PICTURE SETTINGS, and then press ENTER.

The PICTURE SETTINGS menu appears.

3. Press ▲ or ▼ to highlight COLOR TEMPERATURE, and then press ENTER.

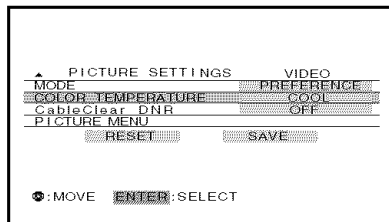

4. Press ◀ or ▶ to select the mode you prefer.

Using the CableClear® DNR feature

CableClear® DNR reduces visible interference in your monitor picture. This is useful when receiving a broadcast with a weak signal (especially a Cable channel) or playing a video cassette or disc damaged by repeated use.

To turn on CableClear® DNR:

1. Press MENU, and then press ◀ or ▶ until the PICTURE menu appears.
2. Press ▲ or ▼ to highlight PICTURE SETTINGS, and then press ENTER.

The PICTURE SETTINGS menu appears.

3. Press ▲ or ▼ to highlight CableClear DNR, and then press ENTER.

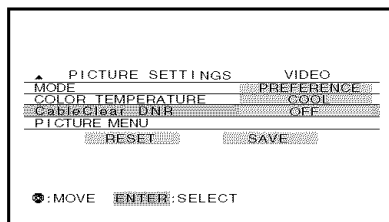

4. Press ◀ or ▶ to select AUTO.

To turn off CableClear® DNR:

Select OFF in step 4 above.

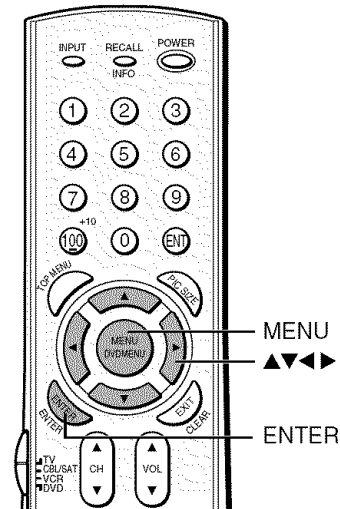

Note:

- When the monitor is in ColorStream or HDMI mode, the words "CableClear DNR" will change to "DNR" in the menu.
- DNR is not selectable when the monitor is in HDMI mode.

Resetting your picture setting adjustments

The RESET function adjusts the picture settings to the following factory settings:

Mode	sports	Tint	center (0)
Contrast	max (100)	Sharpness	center (50)
Brightness	center (50)	Color temperature	cool
Color	center (50)	CableClear DNR	auto

To reset your picture setting adjustments:

1. Press MENU, and then press ◀ or ▶ until the PICTURE menu appears.
2. Press ▲ or ▼ to highlight PICTURE SETTINGS, and then press ENTER. The PICTURE SETTINGS menu appears.
3. Press ▲ or ▼ to highlight RESET.
4. Press ENTER. "RESET" changes to "DONE" in the menu.

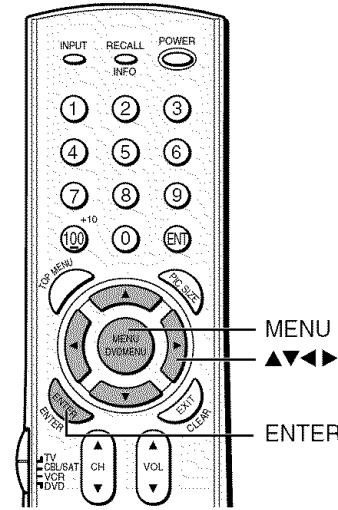
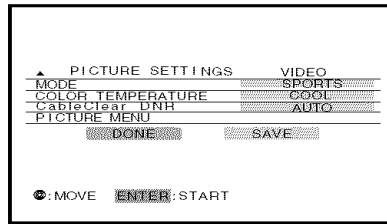

Selecting the display format (for 480p signals only)

You can use this feature to convert 480p input signals to 540p or 1080i.

To select the display format:

1. Press MENU, and then press ◀ or ▶ until the PICTURE menu appears.
2. Press ▲ or ▼ to highlight DISPLAY FORMAT, and then press ENTER.
3. Press ▲ or ▼ to select 540p or 1080i, whichever you prefer.

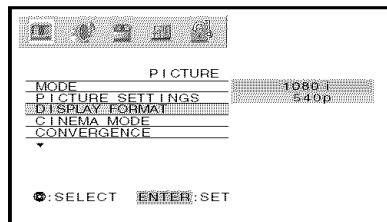

Selecting the cinema mode

When you view a DVD movie (3:2 pull-down processed or interlaced mode) from a DVD player connected to the ColorStream (component video) inputs on the monitor, smoother and more natural motion can be obtained by setting the CINEMA MODE to FILM.

To set the CINEMA MODE to FILM:

1. Press MENU, and then press ◀ or ▶ until the PICTURE menu appears.
2. Press ▲ or ▼ to highlight CINEMA MODE, and then press ENTER.
3. Press ▲ or ▼ to select FILM.

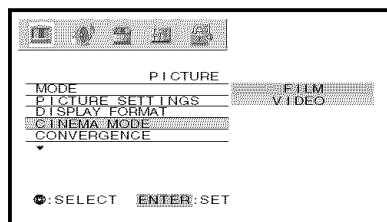

To turn off the CINEMA MODE:

Press ▲ or ▼ to select VIDEO in step 3 above.

Selecting the video input source

Press INPUT on the remote control or the monitor front panel to view a signal from another device connected to your monitor, such as a VCR or DVD player (see illustrations below). You can select VIDEO 1, VIDEO 2, VIDEO 3, ColorStream HD1, ColorStream HD2 or HDMI depending on which input terminals are used for connecting the devices (see “Connecting your Monitor” on page 8).

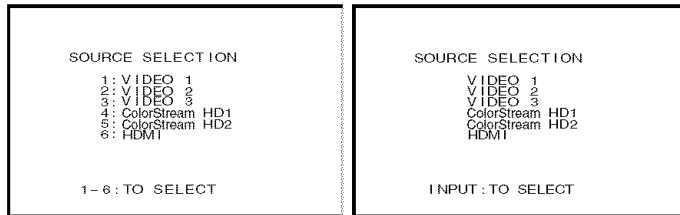

Pressing INPUT on the remote control displays the current signal source (press INPUT again or 1-6 to change)

Pressing INPUT on the monitor changes the current signal source

Labeling the video input sources

The video label feature allows you to label each input source for your monitor from the following preset list of labels:

- : Uses the default label name
- VCR : Video cassette recorder
- DVD : DVD video
- DTV : Digital TV set-top box
- SAT : Satellite box
- CBL : Cable box

For example, if you have a DVD player connected to the monitor's ColorStream HD1 inputs, you would label the ColorStream HD1 input source as “DVD.” Then, when you pressed INPUT, you would see the label “DVD” (instead of ColorStream HD1) in the SOURCE SELECTION list.

To label the video input sources:

1. Press MENU, and then press ◀ or ▶ until the CUSTOM menu appears.
2. Press ▲ or ▼ to highlight VIDEO LABEL.
3. Press ENTER to display the VIDEO LABEL menu.
4. Press ▲ or ▼ to highlight the video source you want to label and then press ENTER.
5. Press ▲ or ▼ to select the desired label for that input source.
6. Finish labeling the other video sources as desired. To return to the previous menu, press ▲ or ▼ to highlight CUSTOM MENU, and then press ENTER.
7. To exit the menu, press EXIT.

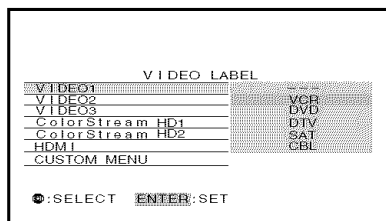
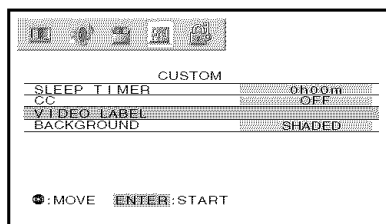

Note:

- When HDMI is selected the VIDEO OUT terminal does not output a signal.
- When ColorStream HD 1 or HD 2 is selected, the VIDEO OUT terminal does not output a signal. To receive a VIDEO OUT signal, use a standard video or S-video IN connection instead of the ColorStream connection.
- In POP double-window mode, the main window will display 480i signals only. If you select ColorStream HD1, ColorStream HD2, or HDMI while the POP picture is active, the message “Not Available” will display.

Note the following regarding the HDMI source selection:

- **Never connect this monitor to a personal computer (PC). This monitor is not intended for use with a PC.**
- See page 15 for details on connecting a device to the HDMI input.

Monitor front panel

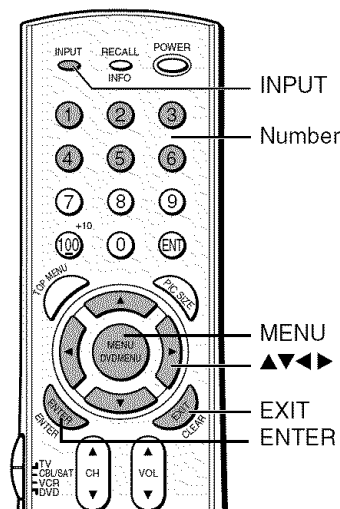
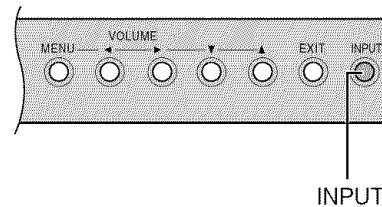

Using the closed caption feature

The closed caption feature has two options:

- Captions—An on-screen display of the dialogue, narration, and sound effects of TV programs and videos that are closed captioned (usually designated “CC” in program listings).
- Text—An on-screen display of information not related to the current program, such as weather or stock data (when provided by individual stations).

To view captions or text:

1. Tune the monitor to the desired program.
2. Press MENU, and then press ◀ or ▶ to display the CUSTOM menu.
3. Press ▲ or ▼ to highlight CC, and then press ENTER.

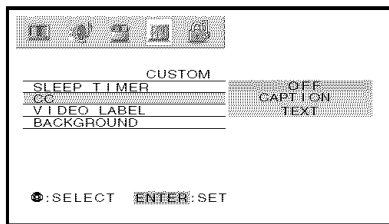

4. Press ▲ or ▼ to highlight CAPTION or TEXT, and then press ENTER.

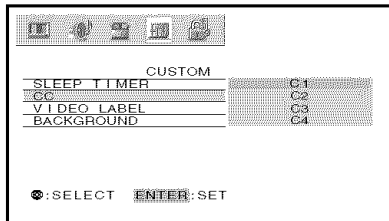

This pull-down menu appears when CAPTION is selected.

- To view captions, highlight CAPTION in step 4 above, and then highlight C1, C2, C3, or C4 (C1 displays translation of the primary language in your area).

Note: If the program or video you selected is not closed captioned, captions will not display on the screen.

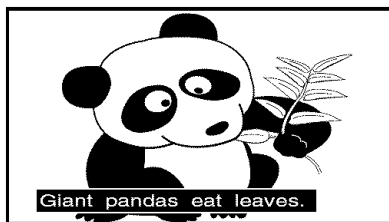

- To view text, highlight TEXT in step 4 above, and then highlight T1, T2, T3, or T4.

Note: If text is not available in your area, a black rectangle may appear on your screen. If this happens, turn the Closed Caption feature OFF.

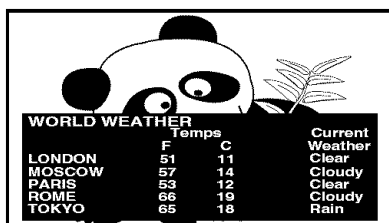

To turn off the Closed Caption feature:
Highlight OFF in step 4.

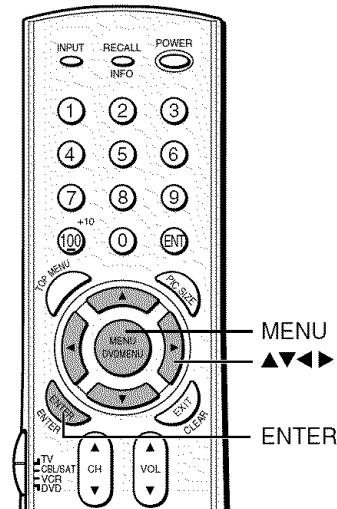

Note:

A closed caption signal may not display in the following situations:

- when a videotape has been dubbed
- when the signal reception is weak
- when the signal reception is nonstandard

NOTICE OF POSSIBLE ADVERSE EFFECTS ON MONITOR PICTURE DISPLAY

Avoid displaying stationary images on your monitor screen for extended periods of time. Fixed (non-moving) patterns or images (including but not limited to PIP/POP windows, closed captions, video game patterns, TV station logos (from VCR, etc.), stock tickers, websites, and special formats that do not use the entire screen) can become permanently ingrained in the cathode ray tube(s) of the monitor and cause subtle but permanent ghost images. **This type of damage is NOT COVERED BY YOUR WARRANTY.** See item 33 on page 4 for details.

Setting the sleep timer

To set the sleep timer to turn off the monitor automatically:

1. Press SLEEP to set the length of time until the monitor turns off.

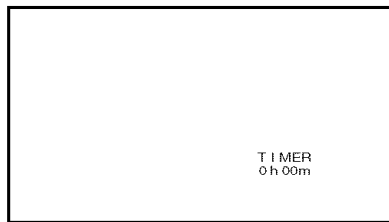

Every time you press the SLEEP, the time display will increase by 10 minutes, up to 3 hours.

0h00m → 0h10m → 0h20m ----- → 2h50m → 3h00m → 0h00m

To cancel the sleep timer:

Press SLEEP until it is set to 0h00m.

The sleep timer can also be set using the on-screen menus:

1. Press MENU, and then press ◀ or ▶ until the CUSTOM menu appears.
2. Press ▲ or ▼ to highlight SLEEP TIMER, and then press ENTER.
3. Press the Number buttons to enter the length of time until the monitor turns off automatically.
4. Press ENTER to start the timer.

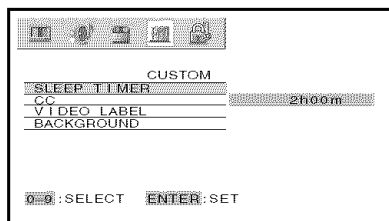

Note :

- When an instant power failure occurs, the sleep timer settings may be cleared.
- To display the amount of time left until the monitor turns on or off automatically, press RECALL.

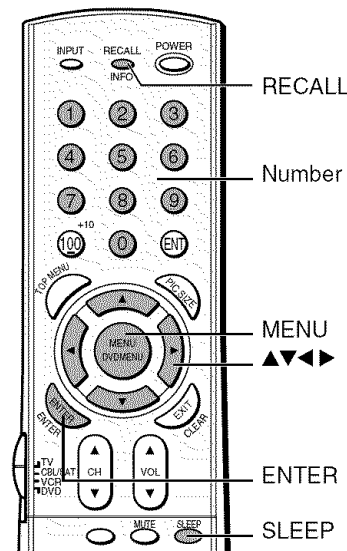

Setting the clock

To set the clock:

1. Press MENU, and then press ◀ or ▶ until the SET UP menu appears.
2. Press ▲ or ▼ to highlight CLOCK SET, and then press ENTER.
3. Press the Number buttons (0-9) to enter the correct time. The clock operates on a 24-hour cycle. (e.g. 1:00 p.m. equals 13:00, 5:00 p.m. equals 17:00.)
4. Press ENTER to start the clock.

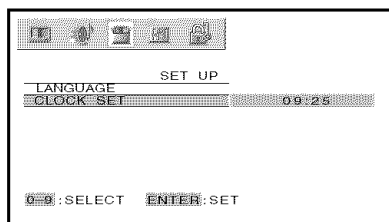

Note :

- If the monitor's power source is interrupted (the power cord is unplugged or a power failure occurs), the clock must be reset.*

To display the time on-screen:

Press RECALL.

Adjusting the sound

Muting the sound

Press MUTE to temporarily reduce (1/2 MUTE) or turn off (MUTE) the sound. While the sound is off, the screen will display “1/2 MUTE” or “MUTE” in the lower right corner. Every time you press MUTE, the mute mode will change in the following order.

→ Normal → 1/2 MUTE → MUTE →

When you select “MUTE” mode, the closed caption feature is automatically activated. To deactivate this feature, deactivate MUTE. This feature works only when the closed caption mode is set to OFF. See “Using the closed caption feature” on page 41 for more information.

Using the WOW® surround sound feature

WOW® is a special combination of SRS Labs audio technologies that creates a thrilling surround sound experience with deep, rich bass from stereo sound sources. Your monitor's audio will sound fuller, richer, and wider.

To adjust the WOW feature:

1. Press MENU, and then press ◀ or ▶ until the AUDIO menu appears.
2. Press ▲ or ▼ to highlight the desired WOW feature you want to adjust, then press ENTER.
 - SRS 3D — To turn on or off the surround sound effect.
 - FOCUS — To turn on or off the vocal emphasis effect.
 - TruBass — To select your desired bass expansion level (HIGH, LOW, or OFF).

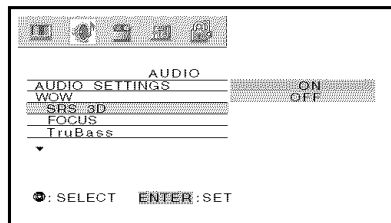

3. Press ▲ or ▼ to select the item, then press ENTER.

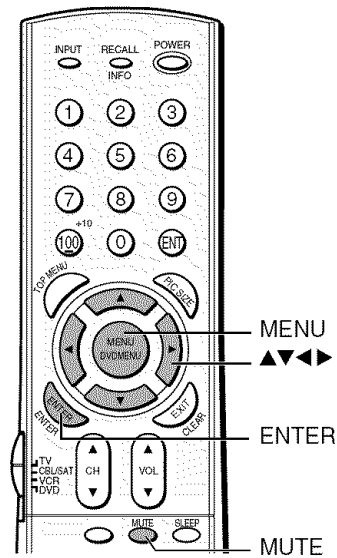

Monitor front panel

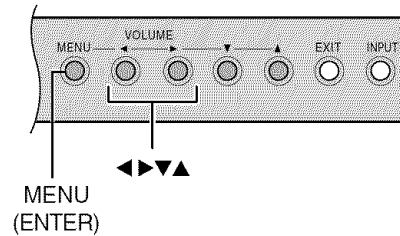

Note:

If the broadcast is monaural, the WOW SRS 3D surround sound effect will not work.

SRS WOW, SRS and ● symbol are trademarks of SRS Labs, Inc.
SRS WOW technology is incorporated under license from SRS Labs, Inc.

Adjusting the sound quality

You can change the quality of your monitor's sound by adjusting the bass, treble, and balance.

To adjust the sound quality:

1. Press MENU, and then press ◀ or ▶ until the AUDIO menu appears.
2. Press ▲ or ▼ to highlight AUDIO SETTINGS, and then press ENTER.

The AUDIO SETTINGS menu appears.

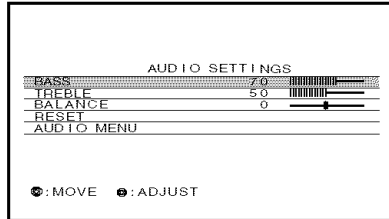

3. Press ▲ or ▼ to highlight the item you want to adjust.
4. Press ◀ or ▶ to adjust the level.
 - ◀ makes the sound quality weaker or increases the balance in the left channel, depending on the item selected.
 - ▶ makes the sound quality stronger or increases the balance in the right channel, depending on the item selected.

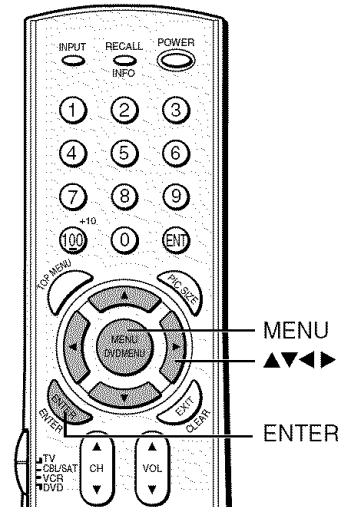

Resetting your audio adjustments

The RESET function returns your audio adjustments to the following factory settings:

- Bass center (50)
- Treble center (50)
- Balance center (0)

To reset your audio adjustments:

1. Press MENU, and then press ◀ or ▶ until the AUDIO menu appears.
2. Press ▲ or ▼ to highlight AUDIO SETTINGS, and then press ENTER.
The AUDIO SETTINGS menu appears.
3. Press ▲ or ▼ to highlight RESET, and then press ENTER.

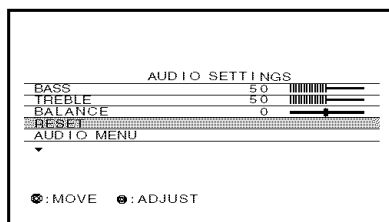

Using the StableSound® feature

When the signal source is changed, the StableSound feature limits the highest volume level to prevent extreme changes in volume (for example, to prevent the sudden increase in volume that often happens when a TV program switches to a commercial).

To turn on the StableSound feature:

1. Press MENU, and then press ◀ or ▶ until the AUDIO menu appears.
2. Press ▲ or ▼ to highlight STABLE SOUND, and then press ENTER.
3. Press ▲ or ▼ to select ON, and then press ENTER.

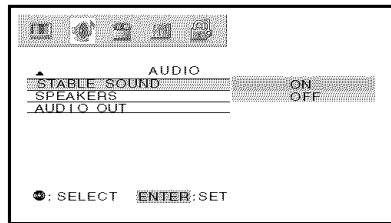

To turn off the StableSound feature:

Select OFF in step 3 above.

Turning off the built-in speakers

Use this feature to turn off the monitor's built-in speakers when you connect an audio system (See "Connecting an audio system" on page 17).

To turn off the built-in speakers:

1. Press MENU, then press ◀ or ▶ until the AUDIO menu appears.
2. Press ▲ or ▼ to highlight SPEAKERS, and then press ENTER.
3. Press ▲ or ▼ to select OFF, and then press ENTER.

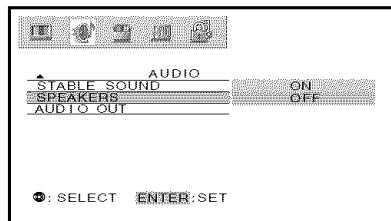

To turn on the built-in speakers:

Select ON in step 3 above.

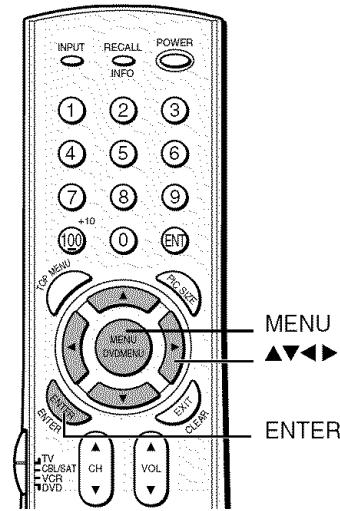

Note:

Make sure the volume control of your audio amplifier is set to a moderate listening level.

Selecting the Audio OUT sound

This feature allows you to select the sound source (MAIN or POP) that is output from the Audio OUT terminals (for example, see “Connecting two VCRs” on page 14).

This is useful when amplifying or recording the POP sound with external equipment (connected to the monitor’s Audio OUT terminals) while listening to the sound of the main picture through the monitor’s built-in speakers.

To select the Audio OUT sound:

1. Press MENU, and then press ◀ or ▶ until the AUDIO menu appears.
2. Press ▲ or ▼ to highlight AUDIO OUT, and then press ENTER.
3. Press ▲ or ▼ to select MAIN or POP, and then press ENTER.

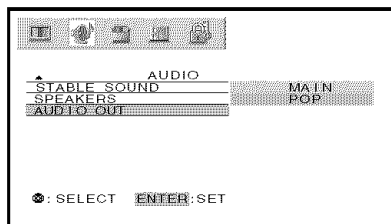

- MAIN: Outputs the sound of the main (left window) program to the Audio OUT terminals.
- POP : Outputs the sound of the POP (right window) program to the Audio OUT terminals.

Selecting the background of the menu display

You can change the background of the menu display by selecting from two preset backgrounds: shaded and solid (gray).

To select the background:

1. Press MENU, and then press ◀ or ▶ until the CUSTOM menu appears.
2. Press ▲ or ▼ to highlight BACKGROUND, and then press ENTER.
3. Press ▲ or ▼ to select either a SHADED or SOLID background, and then press ENTER.

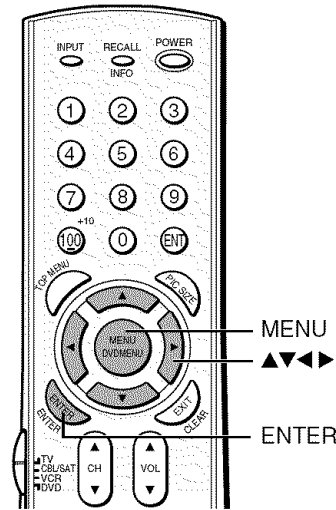
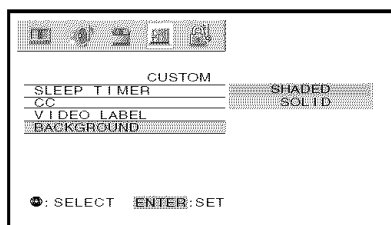

Note:

- When the POP window is closed, the sound of the main program is output through the AUDIO OUT terminals, even if POP is selected in the AUDIO OUT menu.
- The sound of the main program is always output through the monitor’s built-in speakers, regardless of the AUDIO OUT setting.

Displaying monitor status information on-screen

Press **RECALL** to display the following information on-screen:

- Input mode
- Time (if set)
- Remaining time on **SLEEP** timer (if set)
- Video label (when in **VIDEO** mode)
- **V-CHIP** rating status
- Picture size

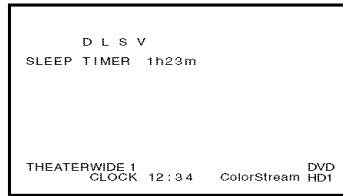

Understanding the last mode memory feature

If the power is cut off while you are viewing the monitor, the Last Mode Memory feature turns on the monitor automatically when the power is resupplied.

If the power is going to be off for a long time and you are going to be away from your monitor, unplug the power cord to prevent the monitor from turning on in your absence.

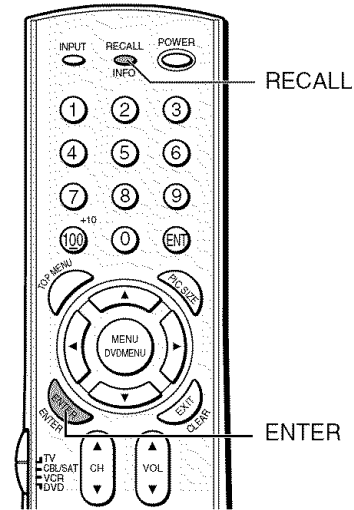

Appendix

Specifications

- This model complies with the specifications listed below.
- Design and specifications are subject to change without notice.
- This model may not be compatible with features and/or specifications that may be added in the future.



WARNING: RISK OF ELECTRIC SHOCK!

Never attempt to service the monitor yourself. Opening and removing the covers may expose you to dangerous voltage or other hazards. Refer all servicing to a Toshiba Authorized Service Center.

Power Source

120 V AC, 60 Hz

Power Consumption

185 W (average)

0.7 W (in standby mode)

Audio Power

15 W + 15 W

Speaker Type

Two 6-5/16 inches (16 cm) round

Video/Audio Terminals

S-VIDEO INPUT

Y : 1 V(p-p), 75 ohms, negative sync.

C : 0.286 V(p-p) (burst signal), 75 ohms

VIDEO/AUDIO INPUT

VIDEO: 1 V(p-p), 75 ohms, negative sync.

AUDIO: 150 mV(rms) (30% modulation equivalent, 22 k ohms or more)

ColorStream® (component video) INPUT

Y : 1V(p-p), 75 ohms

PR: 0.7 V(p-p), 75 ohms

PB: 0.7 V(p-p), 75 ohms

AUDIO: 150 mV(rms), 22 k ohms or more

VIDEO/AUDIO OUTPUT

VIDEO: 1 V(p-p), 75 ohms, negative sync.

AUDIO: 150 mV(rms) (30% modulation equivalent, 2.2 k ohms or less)

Video/Audio Terminals (continued)

VARIABLE AUDIO OUTPUT

0–300 mV(rms) (30% modulation equivalent,

2.2 k ohms or less)

HDMI INPUT

HDMI compliant (type A connector)

HDCP compliant

E-EDID* compliant

Suggested scan rates: 1080i, 480p, 480i, 720p

HDMI Audio 2-channel PCM; 32/44.1/48 kHz sampling frequency; 16/20/24 bits per sample

Dimensions

51HC85: Width 47-3/5 inches (1,209 mm)
Height 50-5/8 inches (1,280 mm)
Depth 22-4/9 inches (570 mm)

57HC85: Width 52-3/4 inches (1,340 mm)
Height 55-1/16 inches (1,399 mm)
Depth 23-7/8 inches (606 mm)

65HC85: Width 59-7/8 inches (1,521mm)
Height 59-7/8 inches (1,521mm)
Depth 26-1/4 inches (665 mm)

Mass

51HC85: 169 lbs (76.8 kg)

57HC85: 230 lbs (105 kg)

65HC85: 240 lbs (108 kg)

Supplied Accessories

- Two dual-wand IR blaster cable
- Remote Control with 2 size “AA” alkaline batteries

*E-EDID = Enhanced-Extended Display Identification

Troubleshooting

Before calling a service technician, please check the following table for a possible cause of the symptom and some solutions.

Symptom	Solution
Monitor will not turn on	<ul style="list-style-type: none">• Make sure the power cord is plugged in, then press POWER.• The remote control batteries may be dead. Replace the batteries.
No picture, no sound	<ul style="list-style-type: none">• If you connected an antenna via an external device (such as a VCR), check the antenna/cable connections.
No sound, picture OK	<ul style="list-style-type: none">• The sound may be muted. Press VOLUME.• Make sure the SPEAKERS function in the AUDIO menu is set properly.
Poor picture, sound OK	<ul style="list-style-type: none">• If you connected an antenna via an external device (such as a VCR), check the antenna/cable connections.• Adjust the PICTURE menu.
Black box appears on the screen	<ul style="list-style-type: none">• The closed caption feature may be set to one of the Text modes (T1, T2, T3, or T4). Turn closed captioning OFF.
Poor color or no color	<ul style="list-style-type: none">• Adjust the TINT and/or COLOR in the PICTURE SETTINGS menu.
The remote control does not operate	<ul style="list-style-type: none">• Make sure the appropriate device mode is selected.• Remove all obstructions between the remote control and the remote control sensor in the monitor.• The remote control batteries may be dead. Replace the batteries.

Limited United States Warranty

for 51HC85, 57HC85, 65HC85

Toshiba America Consumer Products, L.L.C. ("TACP") makes the following limited warranties to original consumers in the United States.

THESE LIMITED WARRANTIES EXTEND TO THE ORIGINAL CONSUMER PURCHASER OR ANY PERSON RECEIVING THIS MONITOR AS A GIFT FROM THE ORIGINAL CONSUMER PURCHASER AND TO NO OTHER PURCHASER OR TRANSFEREE.

MONITORS PURCHASED IN THE U.S.A. AND USED ANYWHERE OUTSIDE OF THE U.S.A., INCLUDING, WITHOUT LIMITATION, CANADA AND MEXICO, ARE NOT COVERED BY THESE WARRANTIES.

MONITORS PURCHASED ANYWHERE OUTSIDE OF THE U.S.A., INCLUDING, WITHOUT LIMITATION, CANADA AND MEXICO, AND USED IN THE U.S.A., ARE NOT COVERED BY THESE WARRANTIES.

Limited One (1) Year Warranty on Parts and Labor

TACP warrants this monitor and its parts against defects in materials or workmanship for a period of one (1) year after the date of original retail purchase. DURING THIS PERIOD, TACP WILL, AT TACP'S OPTION, REPAIR OR REPLACE A DEFECTIVE PART WITH A NEW OR REFURBISHED PART WITHOUT CHARGE TO YOU FOR PARTS OR LABOR. During this period, TACP Authorized Service Station personnel will come to your home when warranty service is required. Depending on the type of repair required, the service will either be performed in your home or the monitor will be taken to a TACP Authorized Service Station for repair and returned to your home at no cost to you.

Limited Two (2) Year Warranty on Picture Tube

TACP warrants the picture tube in this monitor against defects in materials or workmanship for a period of two (2) years after the date of original retail purchase. DURING THIS PERIOD, TACP WILL, AT TACP'S OPTION, REPAIR OR REPLACE A DEFECTIVE PICTURE TUBE WITH A NEW OR REFURBISHED PICTURE TUBE WITHOUT CHARGE TO YOU, PROVIDED THAT IF A DEFECTIVE PICTURE TUBE IS REPAIRED OR REPLACED AFTER ONE (1) YEAR AFTER THE DATE OF ORIGINAL RETAIL PURCHASE, YOU MUST PAY FOR ALL LABOR CHARGES IN CONNECTION WITH THE REPAIR OR REPLACEMENT THEREOF. During this period, TACP Authorized Service Station personnel will come to your home when warranty service is required. Depending on the type of repair required, the service will either be performed in your home or the monitor will be taken to a TACP Authorized Service Station for repair and returned to your home at no cost to you.

Rental Units

The warranty for monitor rental units begins on the date of the first rental or thirty (30) days after the date of shipment to the rental firm, whichever comes first.

Limited Warranty for Commercial Units

TACP warrants monitors that are sold and used for commercial purposes as follows: all parts are warranted against defects in materials or workmanship for a period of ninety (90) days after the date of original retail purchase. DURING THIS PERIOD, TACP WILL, AT TACP'S OPTION, REPAIR OR REPLACE A DEFECTIVE PART WITH A NEW OR REFURBISHED PART WITHOUT CHARGE TO YOU.

Owner's Manual and Product Registration Card

Read this owner's manual thoroughly before operating this monitor.

Complete and mail the enclosed product registration card or register your monitor online at www.tacp.toshiba.com/service as soon as possible. By registering your monitor you will enable TACP to bring you new products specifically designed to meet your needs and help us to contact you in the unlikely event a safety notification is required under the U.S. Consumer Product Safety Act. Failure to complete and return the product registration card does not diminish your warranty rights.

Your Responsibility

THE ABOVE WARRANTIES ARE SUBJECT TO THE FOLLOWING CONDITIONS:

- (1) You must retain your original bill of sale or provide other proof of purchase.
- (2) All warranty servicing of this monitor must be performed by an Authorized TACP Service Station.
- (3) The warranties from TACP are effective only if this monitor is purchased and operated in the Continental U.S.A. or Puerto Rico.
- (4) Labor service charges for set installation, setup, adjustment of customer controls, and installation or repair of antenna systems are not covered by this warranty. Reception problems caused by inadequate antenna systems, misaligned satellite dishes, cable television distribution, VCRs, DVD players/recorders, personal computer level IEEE1394 devices, and any other connected signal source device are your responsibility.
- (5) Warranties extend only to defects in materials or workmanship as limited above, and do not extend to any monitor or parts that have been lost or discarded by you or to damage to the monitor or parts caused by fires, misuse, accident, Acts of God (such as lightning or fluctuations in electric power), improper installation, improper maintenance, or use in violation of instructions furnished by TACP; use or malfunction through simultaneous use of this monitor and connected equipment; or to units that have been modified or had the serial number removed, altered, defaced, or rendered illegible.

How to Obtain Warranty Service

If, after following all of the operating instructions in this manual and reviewing the section entitled "Troubleshooting," you find that service is needed:

- (1) To find the nearest TACP Authorized Service Station, visit TACP's website at www.tacp.toshiba.com/service or contact TACP's Consumer Solution Center toll free at 1-800-631-3811.
- (2) You must present your original bill of sale (or a copy thereof) or other proof of purchase to the TACP Authorized Service Station.

**For additional information, visit TACP's website:
www.tacp.toshiba.com**

ALL WARRANTIES IMPLIED BY THE LAW OF ANY STATE OF THE U.S.A., INCLUDING THE IMPLIED WARRANTIES OF MERCHANTABILITY AND FITNESS FOR A PARTICULAR PURPOSE, ARE EXPRESSLY LIMITED TO THE DURATION OF THE LIMITED WARRANTIES SET FORTH ABOVE. WITH THE EXCEPTION OF ANY WARRANTIES IMPLIED BY THE LAW OF ANY STATE OF THE U.S.A. AS HEREBY LIMITED, THE FOREGOING WARRANTY IS EXCLUSIVE AND IN LIEU OF ALL OTHER WARRANTIES, GUARANTEES, AGREEMENTS, AND SIMILAR OBLIGATIONS OF TACP WITH RESPECT TO THE REPAIR OR REPLACEMENT OF ANY PARTS. IN NO EVENT SHALL TACP BE LIABLE FOR CONSEQUENTIAL OR INCIDENTAL DAMAGES (INCLUDING, BUT NOT LIMITED TO, LOST PROFITS, BUSINESS INTERRUPTION, OR MODIFICATION OR ERASURE OF RECORDED DATA CAUSED BY USE, MISUSE OR INABILITY TO USE THIS MONITOR).

No person, agent, distributor, dealer, or company is authorized to change, modify, or extend the terms of these warranties in any manner whatsoever. The time within which an action must be commenced to enforce any obligation of TACP arising under the warranty or under any statute or law of the United States or any state thereof is hereby limited to ninety (90) days from the date you discover, or should have discovered, the defect. This limitation does not apply to implied warranties arising under the law of any state of the U.S.A.

THIS WARRANTY GIVES YOU SPECIFIC LEGAL RIGHTS AND YOU MAY ALSO HAVE OTHER RIGHTS WHICH MAY VARY FROM STATE TO STATE IN THE U.S.A. SOME STATES OF THE U.S.A. DO NOT ALLOW LIMITATIONS ON THE DURATION OF AN IMPLIED WARRANTY, WHEN AN ACTION MAY BE BROUGHT, OR THE EXCLUSION OR LIMITATION OF INCIDENTAL OR CONSEQUENTIAL DAMAGES. THEREFORE, THE ABOVE PROVISIONS MAY NOT APPLY TO YOU UNDER SUCH CIRCUMSTANCES.

Index

A

- A/V cables (standard) 8
- Audio OUT sound, selecting 46
- Audio system connection 17
- Auto aspect 30

B

- BACKGROUND selection 46
- Back of the monitor 7

C

- CableClear® DNR 38
- Cable converter box connection 10
- Camcorder connection 14
- Cinema mode 39
- Clock, setting 42
- Closed caption 41
- Color convergence 25
- Color temperature 38
- ColorStream® (component video) cables 8
- Convergence adjustment 25

D

- Display format 39
- Double-window (“POP”) feature 31
- DTV receiver connection 13
- DVD connection 11, 12

F H I

- Front of the monitor 7
- HDMI™ connection 15
- INPUT button 40

L M N

- Labeling video input source 40
- Language selection 25
- Last mode memory 47
- Locks menu 33
- Menu system 24
- MUTE button 43
- Number buttons 19

P

- Picture adjustments
 - COLOR TEMPERATURE 38
 - Picture mode 36
 - Picture quality 37
- Picture-out-picture (POP)
 - SOURCE button 31
 - SPLIT button 31
 - SWAP button 32
- Picture scroll 29
- Picture size selection 27
- POP Window 31
- Power button 24

Q R

- RECALL button 47
- Remote control
 - Battery installation 18
 - Effective range 18
 - Learning about the buttons 19
 - Programming 22
- RESET 39, 44

S

- Satellite receiver connection 11
- Scrolling the TheaterWide® picture 29
- Set-top box 13
- Sleep timer 42
- Sound quality adjustments 44
- SPEAKERS on/off 45
- Specifications 48
- SRS 3D surround 43
- StableSound® 45
- S-video cables 8

T

- TheaterWide® picture 28
- Troubleshooting 49

V

- V-CHIP
 - BLOCKING OPTION 35
 - ENABLE BLOCKING 34
 - MPAA RATING 35
 - NEW PIN CODE 36
 - TV RATING 34
- VCR connection 9
- VIDEO LABEL 40

W

- Warranty 50
- WOW® surround sound feature 43

TOSHIBA AMERICA CONSUMER PRODUCTS, L.L.C.

HEAD OFFICE: 82 TOTOWA ROAD, WAYNE, NEW JERSEY 07470, U.S.A.
NATIONAL SERVICE DIVISION: 1420B TOSHIBA DRIVE, LEBANON, TN. 37087, U.S.A.

MANUFACTURED BY

TOSHIBA AMERICA CONSUMER PRODUCTS, L.L.C.

CableClear, ColorStream, StableSound, and TheaterWide are registered trademarks of Toshiba America Consumer Products, L.L.C.

PRINTED IN USA
(05-05)

TOSHIBA

(Y/C/N) 23566643