



ProHeat 2X[®]

USER'S GUIDE

8920, 9200, 9300, 9400 SERIES

- 3 Safety Instructions
- 4 Product view / Accessories
- 5 Assembly
- 6-17 Features / Operations
- 17-18 Maintenance
- 19-20 Troubleshooting
- 21 Consumer Services
- 22-23 Replacement Parts
- 24 Warranty

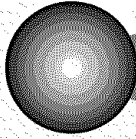

Thanks for buying a BISSELL ProHeat 2X®

We're glad you purchased a BISSELL ProHeat 2X heated formula deep cleaner. Everything we know about floor care went into the design and construction of this complete, high-tech home cleaning system.

Your ProHeat 2X is well made, and we back it with a limited one-year warranty. We also stand behind it with a knowledgeable, dedicated Consumer Services department, so, should you ever have a problem, you'll receive fast, considerate assistance.

My great-grandfather invented the floor sweeper in 1876. Today, BISSELL is a global leader in the design, manufacture, and service of high quality homecare products like your ProHeat 2X.

Thanks again, from all of us at BISSELL.

Mark J. Bissell
President and Chief Executive Officer

IMPORTANT SAFETY INSTRUCTIONS

When using an electrical appliance, basic precautions should be observed, including the following:

Read all instructions before using your PROHEAT 2X®.

⚠️ WARNING: To reduce the risk of fire, electric shock, or injury:

- Do not immerse.
- Use only on surfaces moistened by cleaning process
- Always connect to a properly grounded outlet.
- See Grounding Instructions
- Unplug from outlet when not in use and before conducting maintenance or troubleshooting
- Do not leave machine when it is plugged in
- Do not service machine when it is plugged in
- Do not use with damaged cord or plug
- If appliance is not working as it should, has been dropped, damaged, left outdoors, or dropped into water, have it repaired at an Authorized Service Center
- Use indoors only
- Do not pull or carry by cord, use cord as a handle, close door on cord, pull cord around sharp corners or edges, run appliance over cord, or expose cord to heated surfaces
- Unplug by grasping the plug, not the cord
- Do not handle plug or appliance with wet hands
- Do not put any object into appliance openings, use with blocked opening, or restrict air flow
- Do not expose hair, loose clothing, fingers or body parts to openings or moving parts
- Do not pick up hot or burning objects
- Do not pick up flammable or combustible materials (lighter fluid, gasoline, kerosene, etc.) or use in the presence of explosive liquids or vapor
- Do not use appliance in an enclosed space filled with vapors given off by oil base paint, paint thinner, some moth proofing substances, flammable dust, or other explosive or toxic vapors
- Do not pick up toxic material (chlorine bleach, ammonia, drain cleaner, gasoline, etc.)
- Do not modify the 3-prong grounded plug
- Do not allow to be used as a toy
- Do not use for any purpose other than described in this User's Guide
- Do not operate the appliance unless the nozzle is securely assembled in the location provided
- Do not unplug by pulling on the cord
- Use only manufacturer's recommended attachments
- Always install float before any wet pick up operation

- Use only cleaning products formulated by BISSELL for use in this appliance to prevent internal component damage. See the cleaning fluid section of this guide
- Keep openings free of dust, lint, hair, etc.
- Do not point attachment nozzle at people or animals
- Keep appliance on a level surface
- Turn off all controls before unplugging
- Unplug before attaching the Turbo Brush™
- Be extra careful when cleaning stairs
- Close attention is necessary when used by or near children

WARNING: The Power Cord on this product contains lead, a chemical known to the State of California to cause birth defects or other reproductive harm.

WASH HANDS AFTER HANDLING.

SAVE THESE INSTRUCTIONS.

THIS MODEL IS FOR HOUSEHOLD USE ONLY. Commercial use of this unit voids the manufacturer's warranty.

GROUNDING INSTRUCTIONS

This appliance must be connected to a grounded wiring system. If it should malfunction or break down, grounding provides a safe path of least resistance for electrical current, reducing the risk of electrical shock. The cord for this appliance has an equipment-grounding conductor and a grounding plug. It must only be plugged into an outlet that is properly installed and grounded in accordance with all local codes and ordinances.

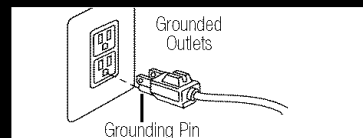

⚠️ WARNING: Improper connection of the equipment-grounding conductor can result in a risk of electrical shock. Check with a qualified electrician or service person if you aren't sure if the outlet is properly grounded. **DO NOT MODIFY THE PLUG.** If it will not fit the outlet, have a proper outlet installed by a qualified electrician. This appliance is designed for use on a nominal 120-volt circuit, and has a grounding attachment plug that looks like the plug in the drawing above. Make certain that the appliance is connected to an outlet having the same configuration as the plug. No plug adapter should be used with this appliance.

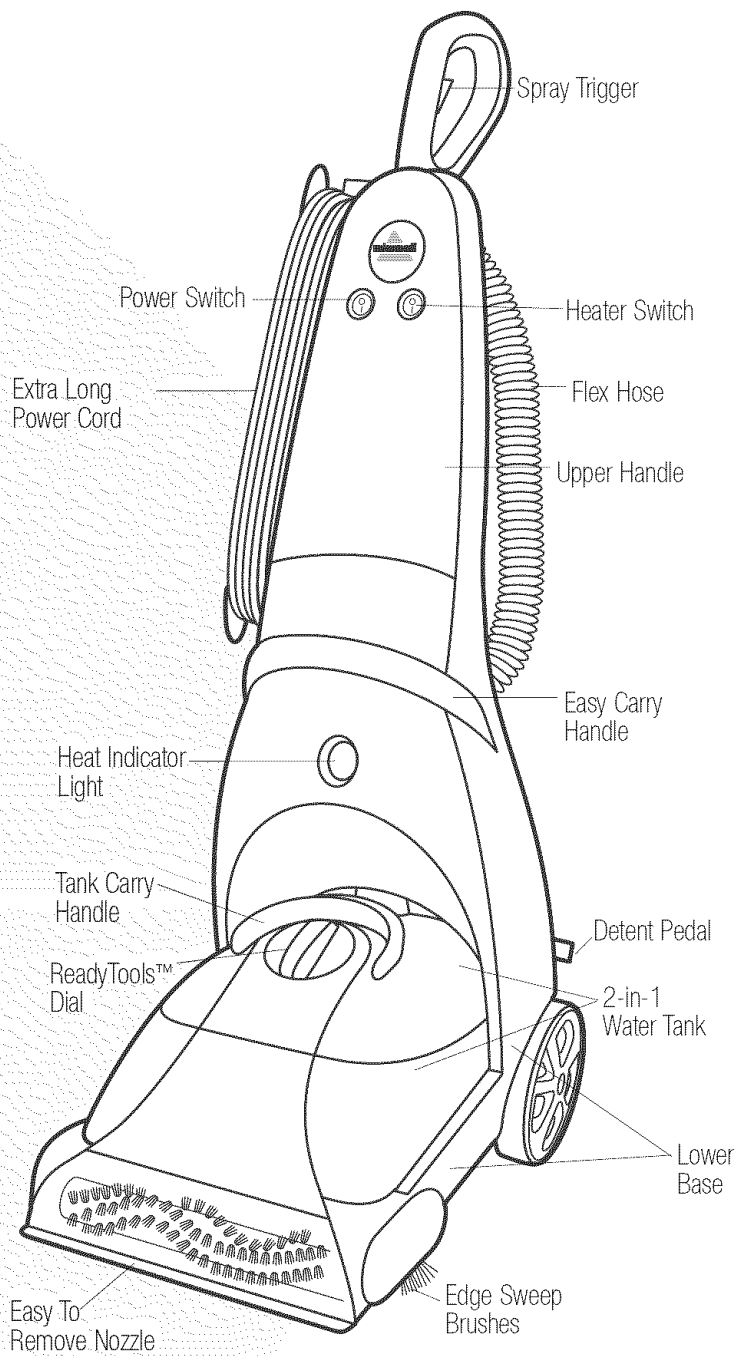

Optional Accessories:

These items are available for purchase with your model. To order replacement parts or additional tools or formulas, please refer to page 22-23.

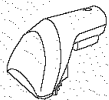

3" Tough Stain Brush

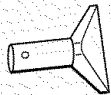

4" Upholstery Tool



6" Wide Stair Tool

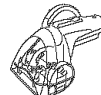

TurboBrush™

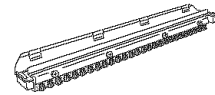

Bare Floor Attachment



Spraying Crevice Tool



Scotchgard protector applicator



Tool Bag

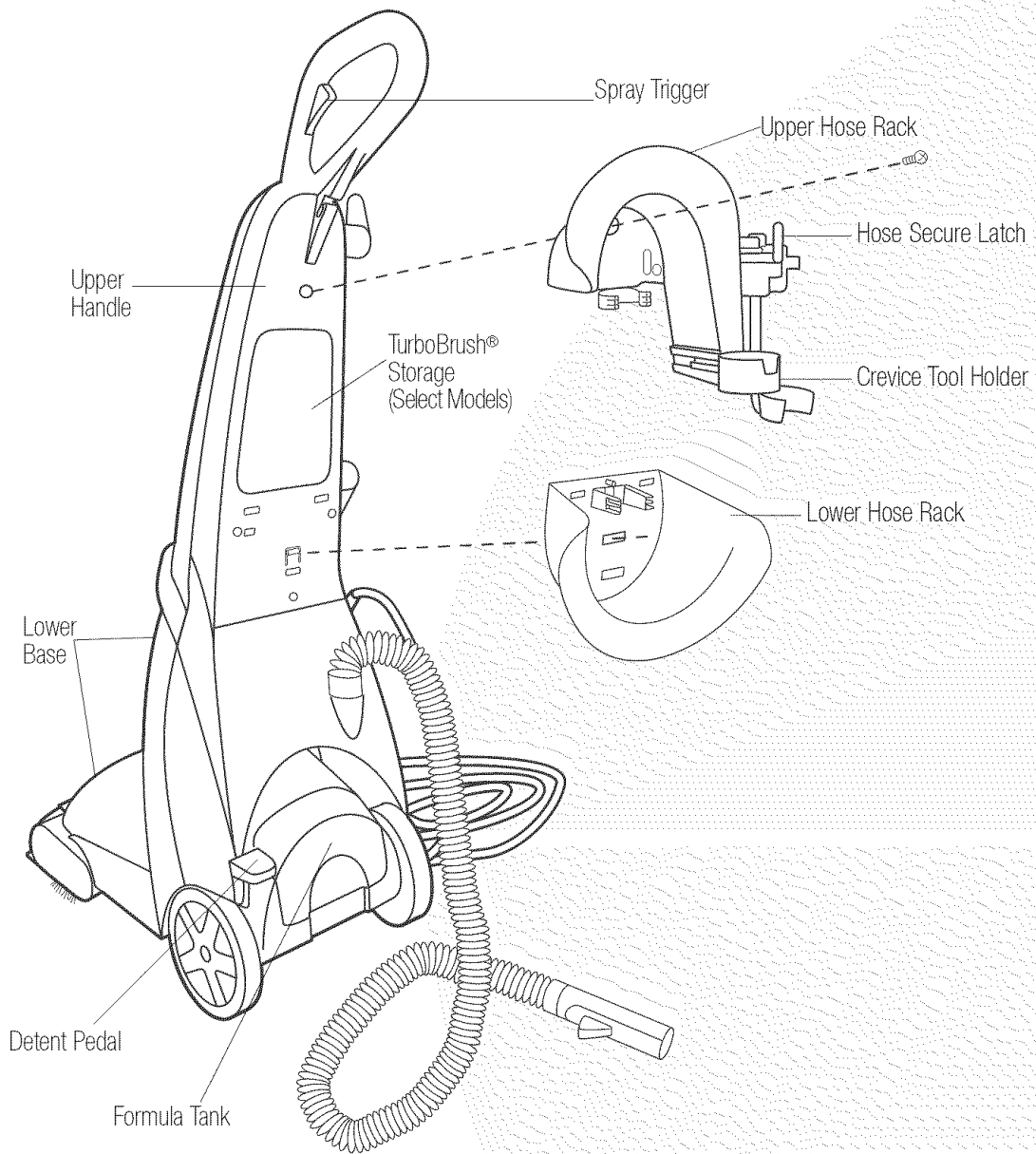

Optional Accessories:

These items are available for purchase with your model. To order replacement parts or additional tools or formulas, please refer to page 22-23.

Keep plenty of genuine BISSELL Advanced Cleaning Formulas on hand so you can clean whenever it fits your schedule. Always use genuine BISSELL deep cleaning formulas. Non-BISSELL cleaning solutions may harm the machine and void the warranty.



16 oz. BISSELL Fiber Cleansing Formula™ with Scotchgard™ Protection



16 oz. Tough Stain PreCleaner™



8 oz. Hard Floor Solutions™



8 oz. Scotchgard protector Cartridge

How to Use this Guide

This User's Guide has been designed to help you get the utmost satisfaction from your BISSELL ProHeat 2X. You'll find assembly and operating instructions, safety precautions, as well as maintenance and troubleshooting instructions. Please read this Guide thoroughly before assembling your Deep Cleaner.

Pay particular attention to the product diagram, assembly instructions, and part names. Locate and organize all parts before assembly. Familiarize yourself with the parts and where they go. Following this User's Guide will greatly enhance your ability to get the most performance from your BISSELL ProHeat 2X for many years.

Your ProHeat 2X comes in four easy to assemble components.

- Upper Handle
- Lower Base
- Tool Caddy (2 pieces)

The only thing you will need to assemble your cleaner is a Phillips head  screwdriver.



WARNING:

Do Not plug in your cleaner until you have completely assembled it per the following instructions and are familiar with all instructions and operating procedures.

How To Put It Together

Refer to Assembly Diagram on page 4

1. Slide Upper Handle onto Lower Handle. Screw in with 3 screws.
2. Place Upper Hose Rack onto back of Upper Handle, and secure with 1 screw.
3. Place Lower Hose Rack onto back of Upper Handle by pushing in and sliding down until it snaps into place.
4. Snap tools into the Tool Caddy as shown in figure 4.
5. Wrap Power Cord and Flex Hose as shown in figure 5.
6. Keep Flex Hose snugly in place by using the Hose Secure Latch.

ProHeat 2X assembly is now complete.

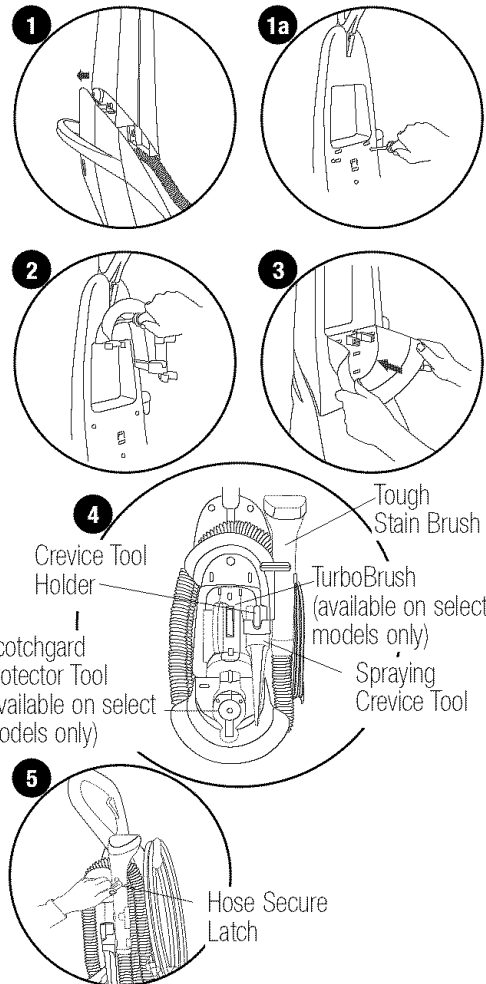

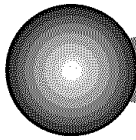

Special Features of Your BISSELL ProHeat 2X

Your BISSELL ProHeat 2X Deep Cleaner is a home cleaning system that uses the power of heat and brushes to get the deep down dirt for a maximum clean. Not only does it come with a lot of unique features, it has been designed with you, the customer, in mind.

Built-in Heater Feature

BISSELL ProHeat models all feature a patented built-in heater which will heat the hot tap water you put in up to 25 degrees hotter to safely optimize cleaning effectiveness. The heater will never allow the temperature to exceed 190 degrees. The Heater switch on the front of the machine controls the heater so you have the option to turn off the heat if you are cleaning delicate wool or oriental rugs.

Dual DirtLifter PowerBrush

The 2 DirtLifter PowerBrush rolls are designed to enhance cleaning performance. The bristle pattern safely lifts out the deep down dirt while gently grooming carpet fibers. The floating suspension self-adjusts to all carpet heights and protects your carpet if you leave the power switch ON (I). Once the product is in the Upright position, the brushes automatically stop spinning. The Detent Pedal will activate the brush when floor cleaning.

Custom Clean™

The Custom Clean feature automatically mixes hot tap water with the BISSELL formula. Simply choose one of the 4 settings (Heavy Traffic, Normal Clean, Light Clean, or Rinse) and the ProHeat 2X will adjust the right amount of cleaning solution to mix with the heated water to fit your cleaning need.

Having a separate solution tank from the water tank also allows no waste of formula. Because the water and solution are stored separately, they are not mixed until you are ready to clean. When your cleaning job is finished, the formula can be stored ready to use in your machine for the next time!

This feature is available on all ProHeat 2X models, either on top of the Water Tank or on the Upper Handle.

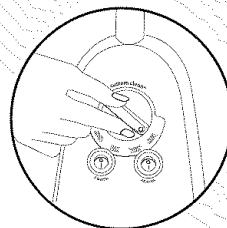
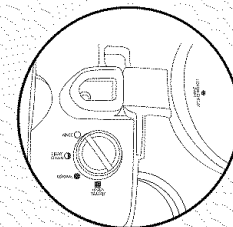

Scotchgard protector Applicator Tool and Scotchgard Warranty

Carpet protection applied at the mill typically wears down with heavy foot traffic over time and with everyday cleaning, including deep cleaning. To help restore this important protection, BISSELL offers deep cleaning formulas with Scotchgard protector and a post-applicator to apply Scotchgard protector with the same materials used by carpet mills. This offers extra protection against dirt and tough stains to keep your carpets looking good longer.

Until now, to maintain your Scotchgard 5-year limited stain warranty, you were required to hire a professional. By using your BISSELL ProHeat 2X machine with BISSELL formulas containing Scotchgard protector every 12 months, your carpet warranty from 3M remains in effect. No other home deep cleaning system can do this for you. Refer to the Scotchgard protector warranty for details.

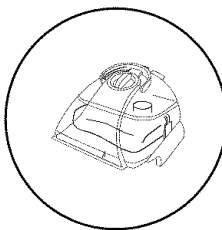
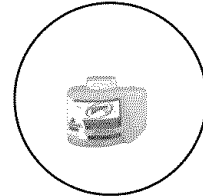
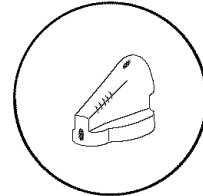

2-in-1 Tank

Our 2-in-1 full capacity tank system is designed with a heavy duty bladder inside for clean water. As you clean, the clean water in the bladder will empty and mix with the cleaning formula. Dirty water pulled out of your carpets will collect around the outside of the bladder so that clean and dirty water are always kept separate. This allows the user to maximize tank space, yet only carry one tank to and from the sink for emptying and filling.

Easy to Remove and Clean Nozzle

Now, cleaning up your machine after the cleaning process is easier than ever! Simply remove the 2-in-1 Tank and remove the screw to pop out the nozzle for rinsing in the sink. Dirt, loose carpet fibers, and remaining pet hair or fuzz gets washed away in a snap.

Ready Tools Dial

This provides either floor cleaning or above the floor cleaning with the turn of a knob. If choosing above floor cleaning for upholstery, stairs, or in those creases close to the baseboards, choose the attachment appropriate for the job, attach it to the flex hose, and you are ready to go!

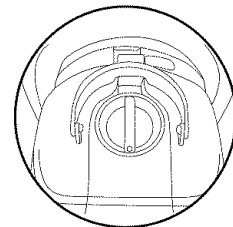

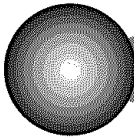

Before You Clean

1. **Plan activities** to give your carpet time to dry
2. **Move furniture** to another area if cleaning an entire room (optional)
3. **Vacuum area** with a dry vacuum cleaner thoroughly before deep cleaning
4. **Pretreating** (optional)

Pretreating is recommended to improve cleaning effectiveness for heavily soiled carpet in high traffic areas such as entryways and hallways.

 - A. Spray the BISSELL Tough Stain Pre-treat formula onto heavy traffic areas, soiled areas, or stains.
 - B. Allow to penetrate for at least 3 minutes
 - C. Clean as normal, using the BISSELL Proheat 2X machine on the High Traffic Setting, following the instructions below.

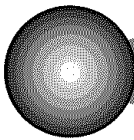

Carpet Cleaning

1. **Fill the Water Tank.** Fill up the 2-in-1 Tank by removing the Tank from the base of the machine with the Tank Carry Handle. Carry like a bucket to the sink. Unlatch the top of the Tank from the bottom by lifting the Tank Latch from the bottom at the back of the tank. Fill up the Heavy Duty Bladder with clean hot tap water. ***Do not boil or microwave water as it can destroy the Bladder.**

Leaving the filled bottom of the Water Tank on a flat surface, only maneuver the top part of the Tank. Replace the top of the Tank to the bottom by carefully hooking the front of the nozzle into the grooves on the bottom of the Tank.

Note: Remember to secure the Tank Latch in the back and test to make sure it is secure before picking up the Tank.

ATTENTION:

Some Berber carpets have a tendency to fuzz with wear. Repeated strokes in the same area with an ordinary vacuum or deep cleaner may aggravate this condition. Please see Stain Removal instructions on page 15.

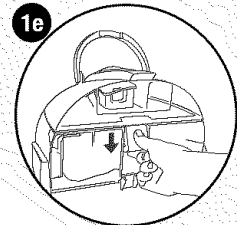
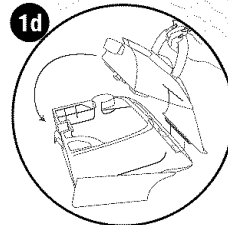
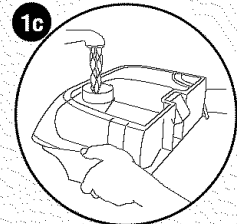
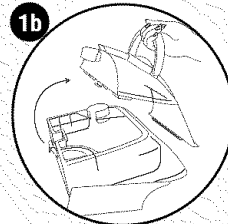
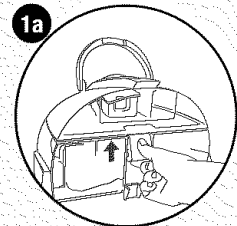
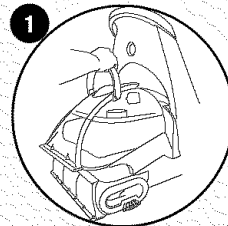

Carpet Cleaning (Continued)

2. Fill the Formula Tank. Fill up the Formula Tank by first unscrewing the Cap and Insert. Always use genuine BISSELL formulas to maximize cleaning and for the safety of your machine. Fill formula up to the line and replace the Cap and Insert. Place Formula Tank into the slot in the back of the machine for a snug fit.

3. Set Custom Clean Dial. Simply choose one of the 4 settings (Heavy Traffic, Normal Clean, Light Clean, or Rinse) and the ProHeat 2X will adjust the right amount of cleaning solution to mix with the heated water to fit your cleaning need.

When your cleaning job is finished, the formula can be stored ready to use in your machine for the next time!

This feature is available on all ProHeat 2X models, either at the foot of the machine, or on the handle.

4. Set Ready Tools Dial to the Floor Cleaning Setting.

5. Turn the Power Switch and Heater On. Plug into a proper outlet and turn the Power and Heater switches to the ON (I) position. Allow 1 minute for the built-in heater to warm-up before cleaning. The ProHeat 2X will be fully warmed and will provide optimal performance after a minute of continuous heated cleaning.

6. Cleaning Strokes. While pressing the Trigger, make one slow forward wet pass and another one back. Let the Built-In Heater, formula, and DirtLifter PowerBrushes do the work for you.
Caution: Do not overwet. Take care not to run over loose objects or edges of area rugs. Stalling brush may result in premature belt failure.

Note: Your machine is equipped with a circuit breaker that will automatically shut off the brush if a large or loose object is caught in the brush roll. If that happens, be sure to unplug your machine, remove the foreign object, and then plug the machine back in to reset the circuit breaker. This can also be done by turning the machine off and back on once the object is removed.

Release the Trigger and make one slow forward and backward pass over the same area to remove any residual dirty water and aid in drying. Repeat cleaning passes until solution being pulled up appears clean. Continue passes without pressing the trigger until you can't see any more water being pulled up. After cleaning, you may want to turn the Custom Clean dial to Rinse to give your carpeting a final Water Only rinse. This will ensure thorough removal of embedded dirt loosened by the deep cleaning formula. BISSELL deep cleaning formulas contain an anti-resoiling agent that helps your carpets repel dirt and keeps them looking good longer.



WARNING:

To Reduce the Risk of Fire and Electric Shock due to internal component damage, use only BISSELL cleaning fluids intended for use with the deep cleaner.

Keep plenty of genuine BISSELL Fiber Cleansing Formula™ and Scotchgard™ protector cartridges on hand so you can clean and protect whenever it fits your schedule. Always use genuine BISSELL deep cleaning formulas. Non-BISSELL cleaning solutions may harm the machine and void the warranty.

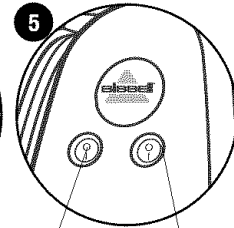
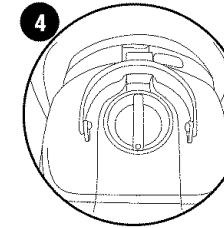
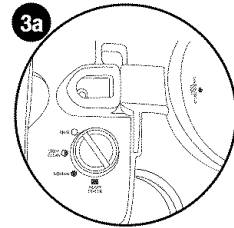
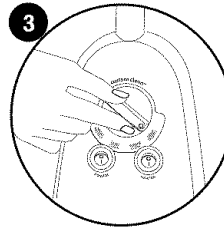
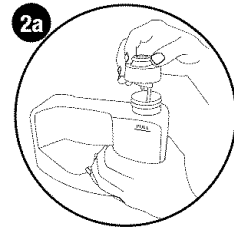
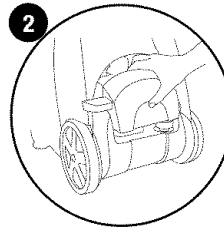

Power Switch

Heater Switch

Carpet Cleaning (Continued)

- 7. Emptying and Re-filling the Tanks.** Remove the Water Tank from the base using the Tank Carry Handle. Carry the Tank like a bucket to a utility sink or outside where you will dispose of the collection water. Unlatch the top of the Tank from the bottom by lifting the Tank Latch. Taking the bottom portion of the Tank, pour out toward the sink from the triangular shaped opening in the bottom of the tank.

Note: You may notice hair & debris deposits on the carpet or in the Tank that were loosened by the cleaning action (especially with newer carpets that have never been deep cleaned before). This debris should be picked up and thrown away.

Fill up the 2-in-1 Tank using instructions on page (9). Remember to secure the Tank Latch in the back and test to make sure it is secure before picking up the Tank. Always check the level of cleaning formula in the Formula Tank at the same time, and refill as needed.

- 8. Rinse (Optional).** Rinsing is an optional step that can be done during the cleaning process by switching from one of the Clean settings on the Custom Clean Dial to a Rinse setting, or it can be done after the carpeted area has been cleaned. Simply choose the Rinse setting on the Custom Clean Dial, and follow the same path as you did for cleaning, taking care to do a forward (wet) stroke by depressing the trigger, a backward (wet) stroke, and a forward and backward (dry) stroke, releasing the trigger. Continue this until the water you see coming up the nozzle is clear.

After You Clean

Once your cleaning is complete, you can simply make sure the Water Tank is emptied, rinsed out, and then put the unit away in a closet or basement for the next use. The Formula Tank can remain filled and ready to go, or it can simply be emptied back into the formula bottle if that is more convenient.

Note: Store cleaner in a protected, dry area. Since this product uses water, it must not be stored where there is a danger of freezing. Freezing will damage internal components and void the warranty.

For best results, a few simple steps can assure your machine is well maintained after your cleaning is complete.

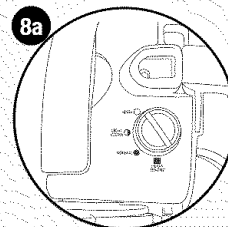
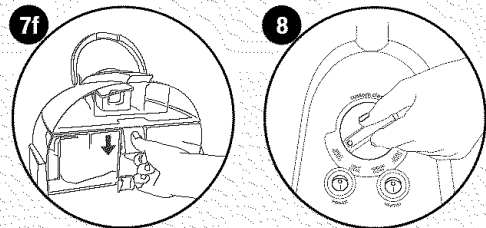
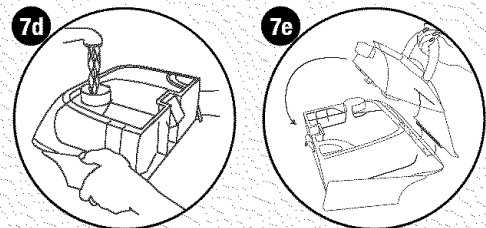
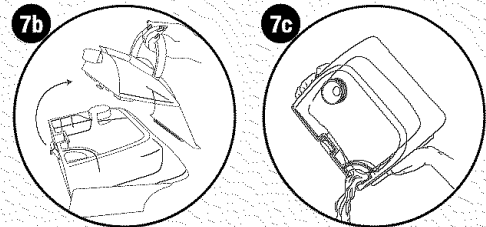
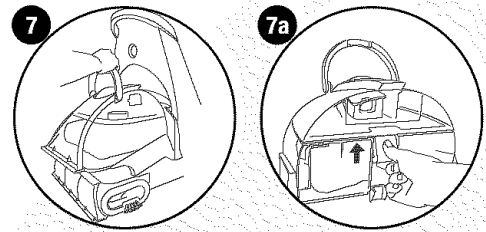

⚠ WARNING:
To reduce the risk of fire, electric shock or injury, unplug from the outlet before servicing.

After You Clean (Continued)

1. Turn Power and Heater switches OFF (O). Unplug the machine and wrap the power cord.
2. After emptying the Water Tank, rinse it out at a faucet with running hot tap water, taking care to clean underneath the Heavy Duty Bladder, and all around it.
3. The top half of the Tank can be rinsed clean through the nozzle area. Also, pop out the Red filter underneath the top half of the Tank and rinse that out. Replace before putting the top and bottom halves of the tank together.
4. Before you place the cleaned Water Tank back onto the machine, simply unscrew the Floor Nozzle using a Phillips head screwdriver (⊗). This can be rinsed out at the faucet. Then replace back onto the machine by starting from the bottom of the nozzle and hooking the tabs into the holes on the bottom sides of the machine. Secure into place with the screw.
5. The inside of the end caps by the brush rolls can be wiped out with a clean paper towel, or, if a more thorough cleaning is desired, the end caps can be taken off using a Phillips head (⊗) screwdriver and rinsed clean. Replace after cleaning.
6. Any loose hair or debris can be pulled from the brush rolls and thrown away. For the most thorough clean before storage, follow directions on pages 17 & 18 for removal and replacement of the brush rolls and belts.
7. After carpet is dry, vacuum again to remove hair and fuzz.

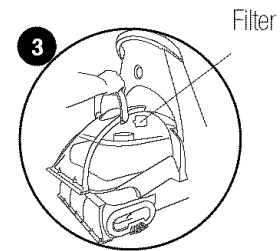

⚠ WARNING:
To reduce the risk of fire,
electric shock or injury,
unplug from the outlet
before servicing.

Post-Treatment Scotchgard Protector (Optional)

A few models are equipped with a Scotchgard Protector post-treatment applicator and cartridge. Using this, along with one of the BISSELL cleaning formulas containing Scotchgard, can be used to help retain the carpet cleanliness achieved with the ProHeat 2X machine. For best results, the post cleaning treatment should be applied while the carpet is still damp. It is recommended that the Scotchgard protector be applied every 12 months to all clean carpeted areas, and after every deep cleaning for high traffic areas such as entryways and stairs.

1. Immediately after cleaning and rinsing your carpets, empty the Water Tank and refill the Heavy Duty Bladder with clean, hot tap water.

Post-Treatment Scotchgard Protector (Optional)

2. Purge the hose to eliminate cleaning solution from the tube by spraying clean water through the hose without attachments into a sink for 15-30 seconds.
3. Attach Scotchgard post-applicator cartridge to the Applicator Tool, following the instructions on the cartridge. Attach the combined Tool/Cartridge to the hose. The water from the 2-in-1 Tank will automatically mix with the concentrated Scotchgard post-treatment formula contained in the cartridge.
4. Turn the Custom Clean Dial to the **Rinse/Protect** setting.
5. Before applying Scotchgard protector to a large area, test in a small, hidden area for colorfastness. Examine area when dry. If color is affected, do not use. For use on upholstery, look for manufacturer's cleanability code tag. Use only on fabrics coded "W" or "WS". If coded "S" or "X", do not use. Not recommended for use on velvet, silk vinyl, leather, or 100% cotton upholstery.
6. Apply Scotchgard protector in a slow sweeping motion with a slight overlap of the treated area. For best coverage, follow the guide on the cartridge.
7. One 8 oz. cartridge protects 200 square feet (18.6 sq. meters). This is equal to two average size rooms, (each at 10 x 10 ft. or 3 x 3 meters). Periodically check the level in the bottle to ensure the best coverage.
8. Be careful not to spray the protector onto furniture or fabric that has not been tested for colorfastness. If this does occur, wipe off the protector.
9. Remove the bottle from the spraying applicator tool. If concentrate is left, replace the cap to the cartridge and store at room temperature for later use.
10. With the applicator tool still on the end of the hose, spray clean hot water into the sink to avoid any future clogging.
11. Store tool in a convenient location for use the next time.

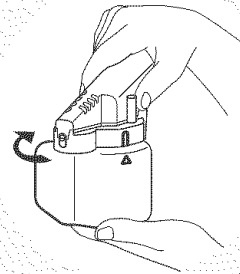
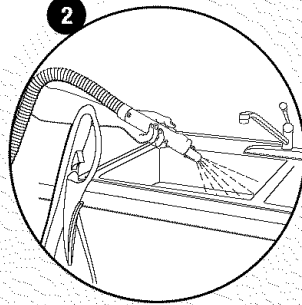

Tip:

If clogged, soak applicator tool in hot tap water before using.

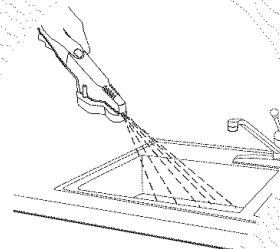
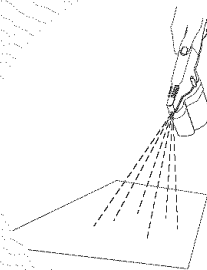

Cleaning With Attachments

Your ProHeat 2X machine comes equipped with a hose and at least 1 attachment for cleaning stairs, upholstery, and more.

- 1.** Important! If using to clean Upholstery, check Upholstery Tags.
 - A.** Check manufacturer's tag before cleaning. "W" or "WS" on the tag means you can use your ProHeat 2X. If the tag is coded with an "X" or an "S" (with a diagonal stripe through it), or says "Dry Clean Only", do not proceed with any deep cleaning machine. Do not use on Velvet or Silk. If manufacturer's tag is missing or not coded, check with your furniture dealer.
 - B.** Check for colorfastness in an inconspicuous place.
 - C.** If possible, check upholstery stuffing. Colored stuffing may bleed through fabric when wet.
 - D.** Plan activities to allow upholstery time to dry.
 - E.** Vacuum thoroughly to pick up loose debris and pet hair. Use a vacuum with a brush attachment and a crevice tool to clean in fabric folds.

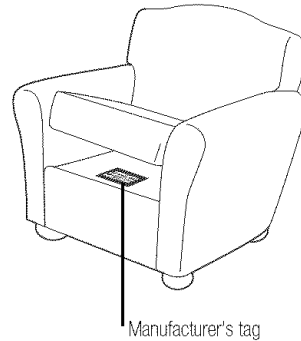

⚠ WARNING:
To reduce the risk of injury, be extra careful when cleaning stairs. Make sure machine is secure and level.

- 2.** Follow the instructions on pages 9 & 10 for filling the Water Tank and the Formula Tank.
- 3.** Set **Ready Tools Dial** to the **Hose Attachments** Setting. This will allow spray and suction from the hose.
- 4.** Set **Custom Clean Dial** for **Heavy Traffic, Normal Clean, Light Clean,** or **Rinse,** as desired.
- 5.** Attach the cleaning tool to the end of the hose.
- 6.** Plug in and turn on the Power Switch and Heater (if desired).
- 7.** Clean by pressing the trigger to spray solution onto the area to be cleaned. Slowly move the tool back and forth over the soiled surface. Release the trigger to suction soiled water. Continue to clean in the area, working in small sections, until no more dirt can be removed. Rinse (optional) and suction as needed.
Caution: Do no overwet.
- 8.** Remove and rinse tools in clean, running water. Dry and replace in the Tool Caddy.
- 9.** It is recommended that you suction clean water from the tap to rinse out the hose. Before replacing lift end of hose and stretch out to ensure all water is cleared from hose.
- 10.** Coil Flex hose around the Tool Caddy.

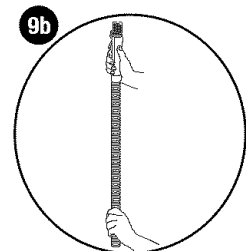
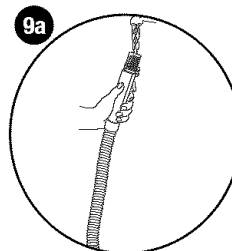
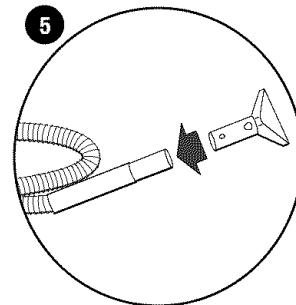

Cleaning With Attachments (Continued)

11. Empty Water Tank and rinse out, following the instructions on page 11.
12. Return Ready Tools Dial to Floor Setting.

Cleaning Fluid Section

Keep plenty of genuine BISSELL Fiber Cleansing Formula™ and Scotchgard™ protector cartridges on hand so you can clean and protect whenever it fits your schedule. Always use genuine BISSELL deep cleaning formulas.



48 oz. BISSELL Fiber Cleansing Formula™ with Scotchgard™ Protection
item # 0710



48 OZ. BISSELL Multi-Allergen Removal™ Formula with Scotchgard™ Protection
item # 0720



48 oz. BISSELL Pet Odor and Soil Removal™ Formula with Scotchgard™ Protection
item # 0730



48 oz. BISSELL Natural Orange Extract Formula™ with Scotchgard™ Protection
item # 0740

⚠ WARNING:
To Reduce the Risk of Fire and Electric Shock due to internal component damage, use only BISSELL cleaning fluids intended for use with the deep cleaner.

Keep plenty of genuine BISSELL Fiber Cleansing Formula™ and Scotchgard™ protector cartridges on hand so you can clean and protect whenever it fits your schedule. Always use genuine BISSELL deep cleaning formulas. Non-BISSELL cleaning solutions may harm the machine and void the warranty.

Stain Removal

Do Not Delay! Attending to an accident soon after it occurs ensures the most optimal clean. Leaving it for an extended period of time may cause it to set and become permanent.

1. Blot up liquids with an absorbent cloth or paper towels. White materials are recommended because certain dyes may bleed and make the stain worse.
2. Gently scrape up any semi-solids with a spoon or spatula. Do not use a knife or other utensil with sharp edges because it could damage the carpet or upholstery.
3. If the area has dried, remove the remaining semi-solids and residue with a sweeper or vacuum.

Stain Removal (Continued)

4. Be sure to test any spot removal formulas in an inconspicuous area first. This is important as some dyes and materials could be damaged or discolored by cleaning solvents. If such a change should occur, try a different solution or call a professional.
5. If cleaning on Berber carpeting, gently run your machine over a hidden area. If no fuzzing occurs, continue cleaning in soiled area.
6. Using the **BISSELL Tough Stain PreCleaner**, spray evenly over soiled area. Do not overwet. Wait 3-5 minutes. Gently work the solution by blotting area with a clean, damp, color safe cloth.
7. Clean using either the **Floor Setting**, or **Hose Attachment Setting** on the **Ready Tools Dial**.



Bare Floor Cleaning

Your ProHeat 2X model may have already come with a Bare Floor attachment and Hard Floor Solutions Formula. If not, these products are available for purchase by contacting the BISSELL Consumer Services department by phone or at the website. The Bare Floor tool provides effective cleaning for linoleum, vinyl, and tile floors.

Caution: Do not use on hardwood floors.

1. Vacuum or Sweep thoroughly to pick up any loose debris and pet hair.
2. Move any furniture, if needed.
3. Empty any carpet cleaning formula back into the BISSELL bottle if stored in the Formula Tank. Fill Formula Tank with BISSELL Hard Floor Solutions, available at many retailers, or contact BISSELL Consumer Services.
4. Fill the Water Tank with Hot Tap Water and Set Aside.
5. Attach the Bare Floor Tool onto the bottom of the machine underneath the Floor Nozzle.
6. Check **Ready Tools Dial**. It should be set on Floor Cleaning.
7. Set the **Custom Clean Dial** to Normal Clean.
8. Plug into an outlet and turn the Power Switch and Heater ON (I).

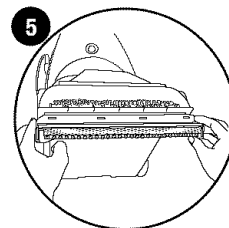

Bare Floor Cleaning (Continued)

9. Slowly move the machine forward and back over bare floor surface one time while depressing trigger. **Caution: Do not overwet.**
10. Repeat the motion without pressing the trigger using the Bare Floor tool to squeegee and suction up the dirty water.
11. Allow approximately 30 minutes for floors to dry.
12. Remove Bare Floor tool and rinse and dry to store.
13. If any formula remains in the Formula Tank, pour it back into the Hard Floor Solutions bottle for use the next time.
14. Rinse out the Formula Tank.

⚠ WARNING:
To reduce the risk of fire,
electric shock or injury,
unplug from the outlet
before servicing.

Belt Removal and Replacement Instructions

Occasional replacement of one or both belts may become necessary. If that is needed, please follow the instructions below.

1. Turn off the machine, and unplug it from the outlet.
2. Remove both the Water Tank and the Formula Tank. Set aside.
3. Unscrew the Front Nozzle and remove it. Set aside.
4. Turn the machine on its side. **IMPORTANT:** cord side down.
5. Remove the Clear End Cap by unscrewing the 2 Black Screws. Take care not to drop the screws into the unit.
6. Remove 1 Silver Screw.
7. Remove Pivot Arm by gently lifting up.
8. Remove Small Brush Belt.
9. Replace Small Brush Belt, and Reverse Steps Above.

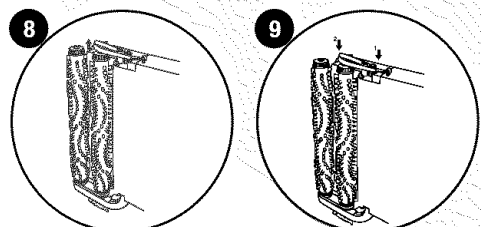
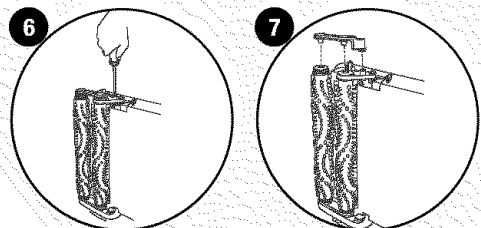
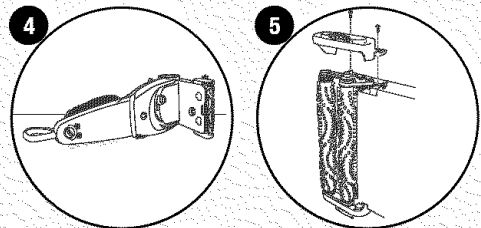
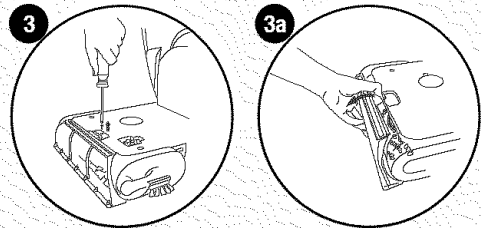
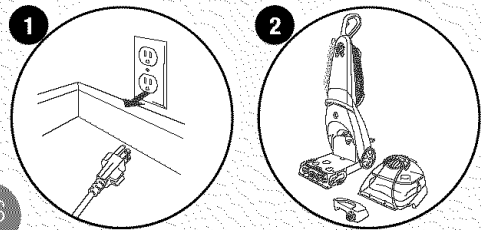

Brush Removal and Replacement Instructions

Brushes can be removed for cleaning or replacement as desired.

1. Follow Belt Removal Instructions on page 17.
2. Remove Brush Rolls by pulling them off of the metal rods.
3. Place Cleaned or New Brush Rolls back onto the rods. Make sure one washer is on each end of the rollers prior to sliding onto the rod. Be sure to let the rod slide through the bushing to insure proper fit.
4. Re-attach the long belt on the bottom to the cogs of the small roller brushes.
5. Place small belt over back roller and metal cog.
6. Place pivot arm in place and screw in place using the Silver screw.
7. Re-attach Clear End Cap by tightening with the (2) Black screws.
8. Return Front Nozzle to front of unit, be latching from underneath and then securing with a screw.

If you have any questions or are having trouble installing or replacing your belt(s) or brushes, please call **BISSELL Consumer Services at 1-800-237-7691**.

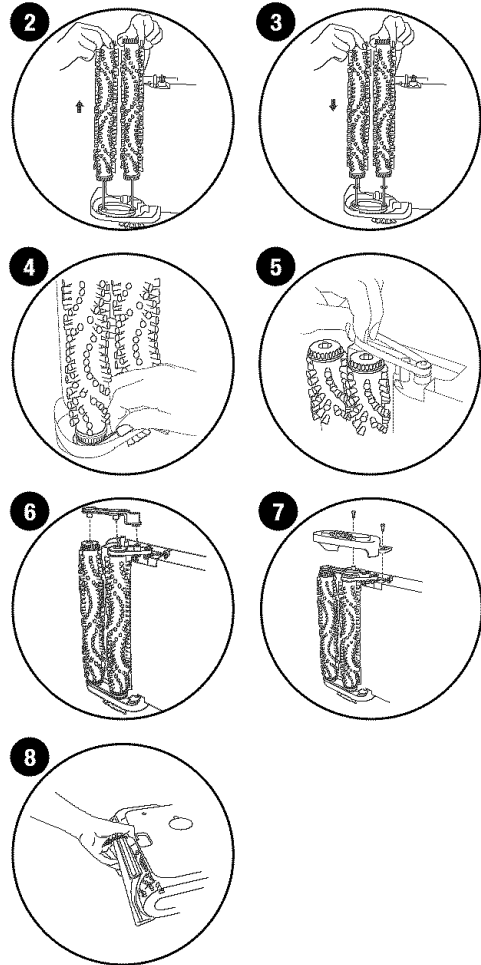

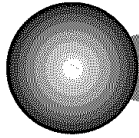

⚠ WARNING:
To reduce the risk of fire, electric shock or injury unplug from outlet before servicing.

Built-in Heater Ready Light does not illuminate.

Possible Causes:

- ❶ The Heater Switch is not turned ON (I)
- ❷ The Power Switch is not turned ON (I)

Remedies:

- ❶ Turn the Heater Switch ON (I).
- ❷ Both switches must be ON (I) to activate the Heater Ready Light.

Reduced Spray or No Spray.

Possible Causes:

- ❶ Water Tank may be empty
- ❷ Formula Tank may be empty
- ❸ Tanks may not be seated completely
- ❹ Pump may have lost prime

Remedies:

- ❶ Fill Heavy Duty Bladder with hot tap water.
- ❷ Fill Formula Tank with BISSELL Fiber Cleansing Formula for cleaning.
- ❸ Turn Power OFF (O). Remove and reseal tanks.
- ❹ Turn Power OFF (O) and then back ON (I). Wait one minute, then depress Trigger.

DirtLifter PowerBrushes do not turn

Possible Causes:

- ❶ The Brush is off or broken
- ❷ The unit is in the upright position
- ❸ Circuit Breaker may have tripped

Remedies:

- ❶ Turn the machine OFF (O) and unplug from outlet. Follow instructions on page 17.
- ❷ Brushes only rotate when unit is reclined using the detent pedal.
- ❸ Turn the machine OFF (O) and unplug from outlet. Check to see if foreign object is caught in brush roll. Remove object. Plug machine back in to reset circuit breaker.

Carpet Protector is not spraying

Possible Causes:

- ❶ Cartridge is not connected to the tool
- ❷ Ready Tools Dial on Floor Setting
- ❸ Solution clogging the Spray Trigger

Remedies:

- ❶ Follow instructions on cartridge to assure proper fit.
- ❷ Set Ready Tools Dial to Hose Attachments Setting.
- ❸ Soak Applicator Tool only in hot water. Spray without the cartridge attached to purge any residual solution left in the tool.

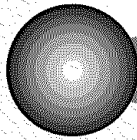

Troubleshooting (Continued)

Cleaner not picking up solution

Possible Causes:

- 1 Ready Tools Dial may be at wrong setting
- 2 Tank may not be seated properly
- 3 Solution or Water Tank is Empty
- 4 2-in-1 Tank has picked up maximum dirty water

Remedies:

- 1 Set Ready Tools Dial to either Floor Cleaning or Hose Attachments Setting.
- 2 Pick up both the Water Tank and Formula Tank and reseal them so they fit snugly on the unit.
- 3 Check fluid levels in Heavy Duty Bladder and Formula Tank.
- 4 Empty 2-in-1 Tank and Refill with Clean Hot Tap water into the Heavy Duty Bladder.

Thank you for selecting a BISSELL product.
If you should happen to need assistance during assembly or operations, call 1-800-237-7691.

Please do not return this product to the store

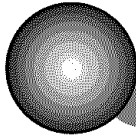

BISSELL Consumer Services

For information about repairs or replacement parts, or questions about your warranty, call:

BISSELL Consumer Services

1-800-237-7691

Monday - Friday 8 a.m. — 10 p.m. EST

Saturday 9 a.m. — 8 p.m. EST

Or write:

BISSELL HOMECARE, INC

PO Box 3606

Grand Rapids MI 49501

ATTN: Consumer Services

Or visit the BISSELL website - www.bissell.com

When contacting BISSELL, have model number of unit available.

Please record your Model Number: _____

Please record your Purchase Date: _____

NOTE: Please keep your original sales receipt. It provides proof of date of purchase in the event of a warranty claim. See "About Your Warranty" on page 24 for details.

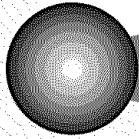

Replacement parts - BISSELL ProHeat 2X®

Replacement Parts

Below is a list of common replacement parts. While not all of these parts may have come with your specific machine, all are available to you for purchase, if desired.

Item	Part No.	Part Name
1	203-6651	3" Tough Stain Tool
2	203-6652	Powered TurboBrush Hand Tool
3	203-6653	4" Upholstery Tool
4	203-6654	6" Wide Stair Tool
5	203-6655	Spraying Crevice Tool
6	203-6692	Bare Floor Tool
7	203-6691	Scotchgard Applicator Tool
8	203-6611	Grey Tank Assembly (complete) for Black unit (Blue or Purple complete tank assemblies available upon request)
9	203-6660	Grey Tank Lid (Blue or Purple Tank Lids available upon request)
10	203-6618	Grey Tank Bottom (Blue or Purple Tank Bottoms available upon request)
11	203-6601	Hose Assembly
12	203-6675	Cap and Insert for Water Tank
13	203-6676	Formula Tank (includes Cap & Insert for Formula Tank)
14	203-6677	Cap and Insert for Formula Tank
15	203-6678	Front Nozzle (includes gasket)
16	203-6679	Autoload Gasket (fits both Water and Formula Tank)
17	203-6680	Filter with Door
18	203-6681	Water Tank Latch
19	203-6682	Cord Wrap (Black) (Blue or Purple cord wrap available upon request)
20	203-6685	Clear End Cap w/Edge Brushes (2 pack, includes screws)
21	203-6686	Brush Roll – 6 row (includes 1 brush, axle, 2 swivel arms)
22	203-6688	Brush Belt (non-cord side)
23	203-6689	Hose Secure Latch
24	203-6690	Hose Rack Assembly (Top/Bottom Hose Rack, Screws)
25	0710	Fiber Cleansing Formula 48 oz.
26	0720	Multi-Allergen Removal Formula 48 oz.
27	0730	Pet Odor and Soil Removal Formula 48 oz.
28	0464	Scotchgard protector Post Treatment Cartridge

*Not all parts are included with every model.

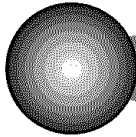

Replacement parts - BISSELL ProHeat 2X[®]



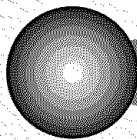

About Your Warranty

This warranty gives you specific legal rights, and you may also have other rights which may vary from state to state. If you need additional instruction regarding this warranty or have questions regarding what it may cover, please contact BISSELL Consumer Services by E-mail, telephone, or regular mail as described below.

Limited **One Year** Warranty

Subject to the ***EXCEPTIONS AND EXCLUSIONS** identified below, upon receipt of the product BISSELL Homecare Inc. will repair or replace (with new or remanufactured components or products), at BISSELL's option, free of charge from the date of purchase by the original purchaser, for one year any defective or malfunctioning part.

See information below on "If your BISSELL product should require service".

This warranty applies to product used for personal, and not commercial or rental service. This warranty does not apply to routine maintenance components such as filters, belts, or brushes. Damage or malfunction caused by negligence, abuse, neglect, unauthorized repair, or any other use not in accordance with the User's Guide is not covered.

If your BISSELL product should require service:

Contact BISSELL Consumer Services to locate a BISSELL Authorized Service Center in your area.

NOTE: Please keep your original sales receipt. It provides proof of date of purchase in the event of a warranty claim.

If you need information about repairs or replacement parts, or if you have questions about your warranty, contact BISSELL Consumer Services.

Website or E-mail:

www.bissell.com

Use the "Customer Services" tab.

Or Call:

BISSELL Consumer Services

1-800-237-7691

Monday - Friday 8 a.m. - 10 p.m. EST

Saturday 9 a.m. - 8 p.m. EST

Or write:

BISSELL Homecare Inc.

PO Box 3606

Grand Rapids MI 49501

ATTN: Consumer Services

BISSELL HOME CARE, INC. IS NOT LIABLE FOR INCIDENTAL OR CONSEQUENTIAL DAMAGES OF ANY NATURE ASSOCIATED WITH THE USE OF THIS PRODUCT. BISSELL'S LIABILITY WILL NOT EXCEED THE PURCHASE PRICE OF THE PRODUCT.

Some states do not allow the exclusion or limitation of incidental or consequential damages, so the above limitation or exclusion may not apply to you.

***EXCEPTIONS AND EXCLUSIONS FROM THE TERMS OF THE LIMITED WARRANTY**

THIS WARRANTY IS EXCLUSIVE AND IN LIEU OF ANY OTHER WARRANTIES EITHER ORAL OR WRITTEN. ANY IMPLIED WARRANTIES WHICH MAY ARISE BY OPERATION OF LAW, INCLUDING THE IMPLIED WARRANTIES OF MERCHANTABILITY AND FITNESS FOR A PARTICULAR PURPOSE, ARE LIMITED TO THE ONE YEAR DURATION FROM THE DATE OF PURCHASE AS DESCRIBED ABOVE.

Some states do not allow limitations on how long an implied warranty lasts, so the above limitation may not apply to you.



©2005 BISSELL HOME CARE, Inc.
Grand Rapids, Michigan
All rights reserved. Printed in China.
Part Number 310-5827
Rev 6/05

Visit our website at:
www.bissell.com

Scotchgard is a trademark of 3M