

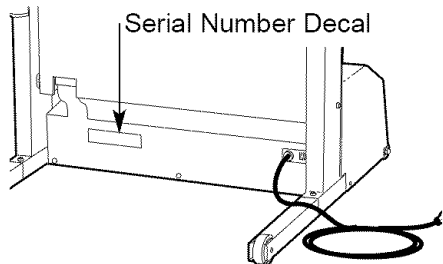

Model No. WLTL29011

Serial No. _____

Write the serial number in the space above for future reference.



USER'S MANUAL

QUESTIONS?

If you have questions, or if there are missing parts, we will guarantee complete satisfaction through direct assistance from our factory.

TO AVOID UNNECESSARY DELAYS, PLEASE CALL DIRECT TO OUR TOLL-FREE CUSTOMER HOT LINE. The trained technicians on our customer hot line will provide immediate assistance, free of charge to you.

CUSTOMER HOT LINE:

1-800-999-3756

Mon.-Fri., 6 a.m.-6 p.m. MST

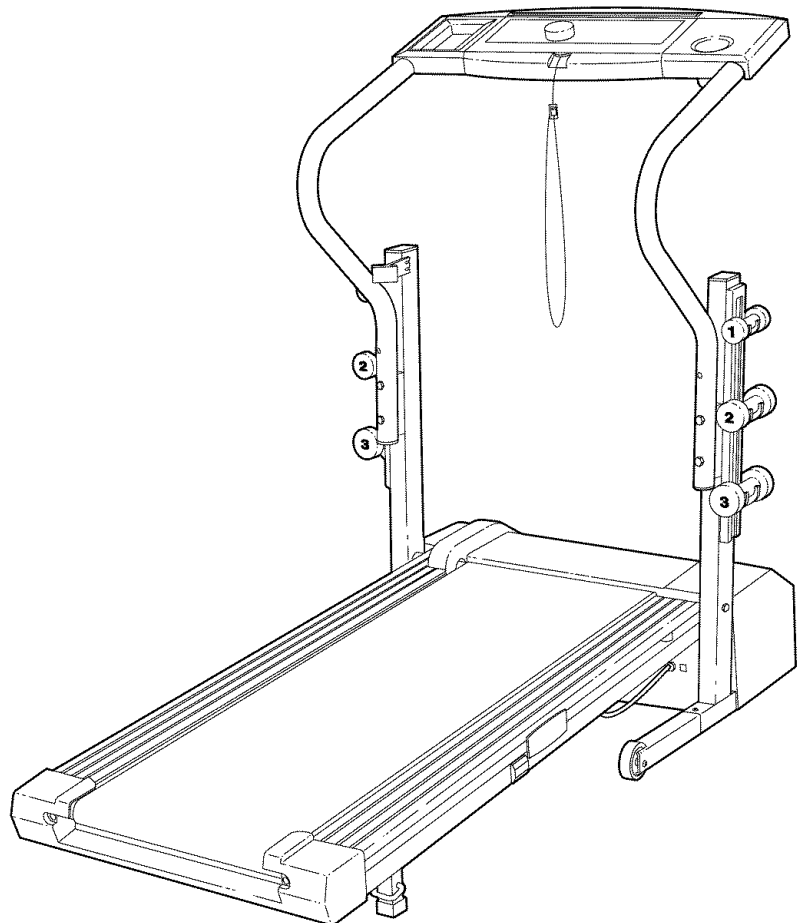

⚠ CAUTION

Read all precautions and instructions in this manual before using this equipment. Save this manual for future reference.



Visit our website at

www.weslo.com

new products, prizes,
fitness tips, and much more!

TABLE OF CONTENTS

IMPORTANT PRECAUTIONS	2
BEFORE YOU BEGIN	4
ASSEMBLY	5
OPERATION AND ADJUSTMENT	7
HOW TO FOLD AND MOVE THE TREADMILL	10
MAINTENANCE AND TROUBLE-SHOOTING	12
CONDITIONING GUIDELINES	14
ORDERING REPLACEMENT PARTS	Back Cover
LIMITED WARRANTY	Back Cover

Note: A PART LIST and an EXPLODED DRAWING are attached in the center of this manual.

IMPORTANT PRECAUTIONS

⚠ WARNING: To reduce the risk of burns, fire, electric shock, or injury to persons, read the following important precautions and information before operating the treadmill.

1. It is the responsibility of the owner to ensure that all users of this treadmill are adequately informed of all warnings and precautions.
2. Use the treadmill only as described in this manual.
3. Place the treadmill on a level surface, with at least eight feet of clearance behind it. Do not place the treadmill on any surface that blocks air openings. To protect the floor or carpet from damage, place a mat under the treadmill.
4. Keep the treadmill indoors, away from moisture and dust. Do not put the treadmill in a garage or covered patio, or near water.
5. Do not operate the treadmill where aerosol products are used or where oxygen is being administered.
6. Keep children under the age of 12 and pets away from the treadmill at all times.
7. The treadmill should not be used by persons weighing more than 250 pounds.
8. Never allow more than one person on the treadmill at a time.
9. Wear appropriate exercise clothing when using the treadmill. Do not wear loose clothing that could become caught in the treadmill. Athletic support clothes are recommended for both men and women. Always wear athletic shoes. Never use the treadmill with bare feet, wearing only stockings, or in sandals.
10. When connecting the power cord (see page 7), plug the power cord into a surge suppressor (not included) and plug the surge suppressor into a grounded circuit capable of carrying 15 or more amps. No other appliance should be on the same circuit. Do not use an extension cord.
11. Use only a single-outlet surge suppressor that is UL 1449 listed as a transient voltage surge suppressor (TVSS). The surge suppressor must have a UL suppressed voltage rating of 400 volts or less and a minimum surge dissipation of 450 joules. The surge suppressor must be electrically rated for 120 volts AC and 15 amps. To purchase a surge suppressor, see your local WESLO dealer or call 1-800-999-3756 and order part number 146148.
12. Keep the power cord and the surge suppressor away from heated surfaces.

13. Never move the walking belt while the power is turned off. Do not operate the treadmill if the power cord or plug is damaged, or if the treadmill is not working properly. (See **BEFORE YOU BEGIN** on page 4 if the treadmill is not working properly.)
14. Never start the treadmill while you are standing on the walking belt. Always hold the handrails while using the treadmill.
15. Using hand weights and not holding the handrails may compromise your ability to maintain your balance. Hand weights should be used only by experienced users.
16. The treadmill is capable of high speeds. Adjust the speed in small increments to avoid sudden jumps in speed.
17. Never leave the treadmill unattended while it is running. Always remove the key and unplug the power cord when the treadmill is not in use.
18. Do not attempt to raise, lower, or move the treadmill until it is properly assembled. (See **ASSEMBLY** on page 5, and **HOW TO FOLD AND MOVE THE TREADMILL** on page 10.) You

- must be able to safely lift 45 pounds (20 kg) in order to raise, lower, or move the treadmill.
19. Do not change the incline of the treadmill by placing objects under the treadmill.
20. When folding or moving the treadmill, make sure that the storage latch is fully closed.
21. Inspect and tighten all parts of the treadmill every three months.
22. Never insert or drop any object into any opening.
23. **DANGER:** Always unplug the power cord immediately after use, before cleaning the treadmill, and before performing the maintenance and adjustment procedures described in this manual. Never remove the motor hood unless instructed to do so by an authorized service representative. Servicing other than the procedures in this manual should be performed by an authorized service representative only.
24. This treadmill is intended for in-home use only. Do not use this treadmill in any commercial, rental, or institutional setting.

⚠ WARNING: Before beginning this or any exercise program, consult your physician. This is especially important for persons over the age of 35 or persons with pre-existing health problems. Read all instructions before using. ICON assumes no responsibility for personal injury or property damage sustained by or through the use of this product.

SAVE THESE INSTRUCTIONS

The decal shown below has been placed on your treadmill. If the decal is missing or illegible, please call our Customer Service Department, toll-free, to order a free replacement decal (see **ORDERING REPLACEMENT PARTS** on the back cover of this manual). Apply the decal in the location shown.

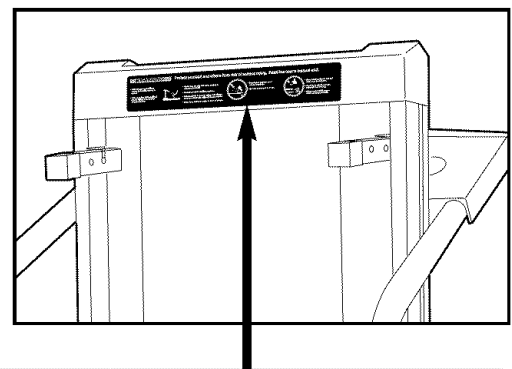

Note: This decal is shown at 38% of actual size.

⚠ WARNING: Protect yourself and others from risk of serious injury. Read the user's manual and:

<ul style="list-style-type: none"> • Fully engage storage latch before treadmill is moved or stored. • Reduce incline to lowest level before folding treadmill into storage position. 		<ul style="list-style-type: none"> • Stand only on side rails when starting or stopping treadmill. • Change speed in small increments. • Hold handrails to prevent falling, and always wear the safety clip while operating treadmill. • Stop if you feel faint, dizzy, or short of breath. 		<ul style="list-style-type: none"> • Never allow children on or around treadmill. • Remove key when not in use. 		<ul style="list-style-type: none"> • Keep clothing, fingers, and hair away from moving belt. • Never try to adjust or fix the belt while it is moving. • Always wear athletic shoes while operating treadmill.
---	---	---	---	---	---	---

BEFORE YOU BEGIN

Thank you for selecting the WESLO® CADENCE 340 CS treadmill. The CADENCE 340 CS combines advanced technology with innovative design to let you enjoy an excellent form of cardiovascular exercise in the convenience and privacy of your home. And when you're not exercising, the CADENCE 340 CS can be folded up, re-quiring less than half the floor space of other treadmills.

please call our Customer Service Department toll-free at 1-800-999-3756, Monday through Friday, 6 a.m. until 6 p.m. Mountain Time (excluding holidays). To help us assist you, please note the product model number and serial number before calling. The model number of the treadmill is WLTL29011. The serial number can be found on a decal attached to the treadmill (see the front cover of this manual for the location).

For your benefit, read this manual carefully before using the treadmill. If you have additional questions,

Before reading further, please familiarize yourself with the parts that are labeled in the drawing below.

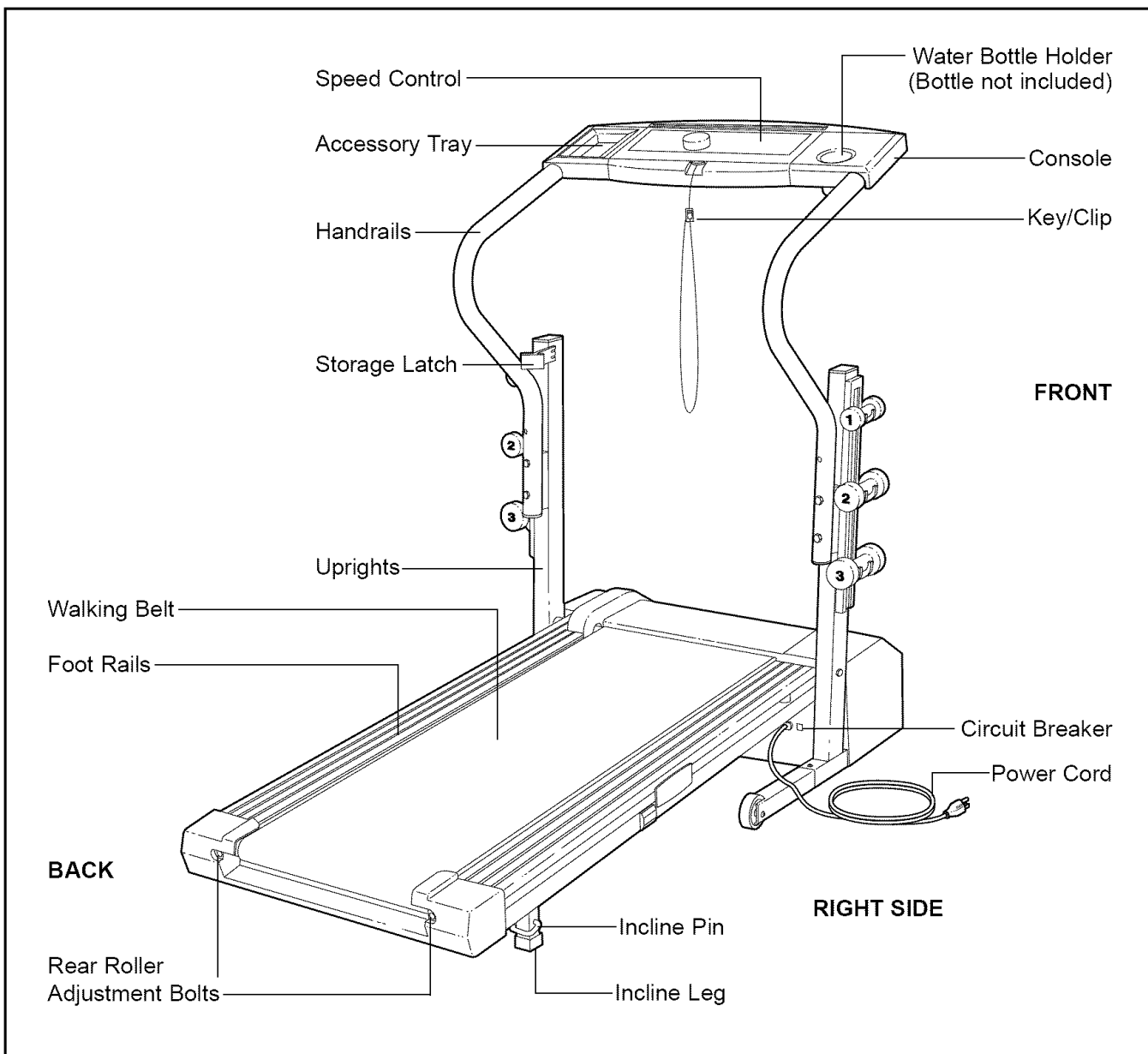

ASSEMBLY

Assembly requires two people. Set the treadmill in a cleared area and remove all packing materials. Do not dispose of the packing materials until assembly is completed. **In addition to the included allen wrench, assembly requires a phillips screwdriver, an adjustable wrench and scissors.**

Note: The underside of the treadmill walking belt is coated with high-performance lubricant. During shipping, a small amount of lubricant may be transferred to the top of the walking belt or the shipping carton. This is a normal condition and does not affect treadmill performance. If there is lubricant on top of the walking belt, simply wipe off the lubricant with a soft cloth and a mild, non-abrasive cleaner.

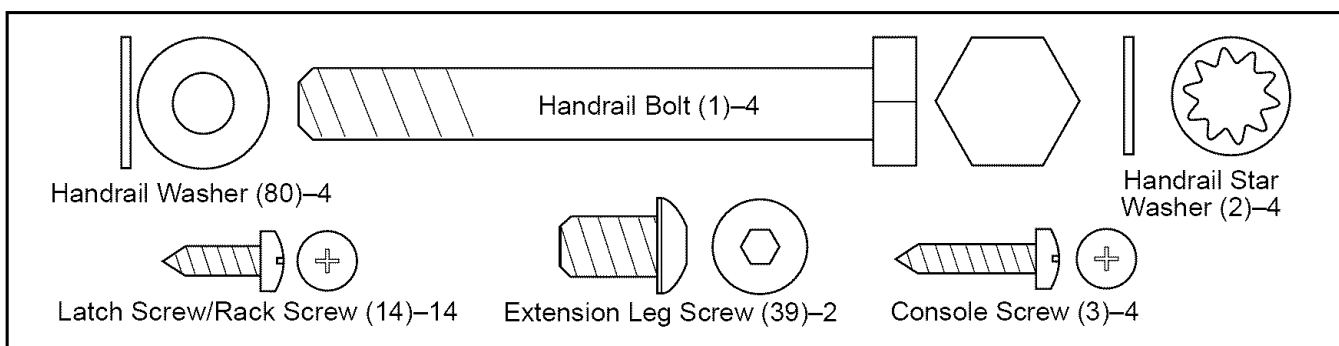

1. With the help of a second person, raise the Uprights (38) to the position shown. **During this step and step 2, be careful not to pull on or damage the Wire Harness (53) in the right Handrail (4).**

Insert one of the Base Legs (44) into the right Upright (38), with the Base Leg Pad (33) in the indicated position. Using the included Allen Wrench (81), attach the Base Leg with a Base Leg Screw (39). Attach the other Base Leg (not shown) to the left Upright in the same way. Note: A replacement Base Leg Pad (33) may be included. If a Base Leg Pad becomes worn and needs to be replaced, use the replacement Base Leg Pad.

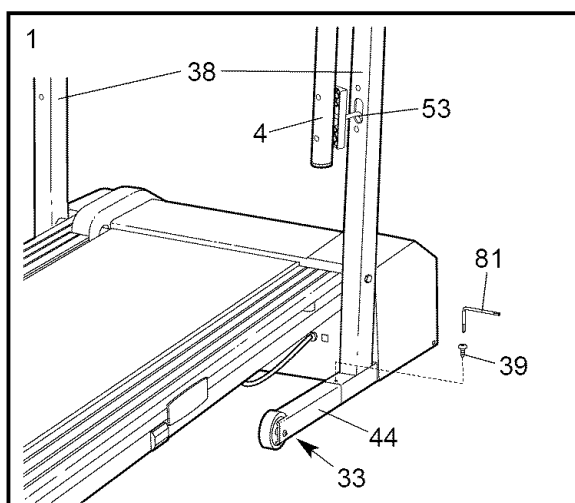

2. Hold a Handrail (4) against the left Upright (38) as shown. **Important: If you are shorter than 5' 8", align the upper two holes in the Handrail with the holes in the Upright; if you are 5' 8" or taller, align the lower two holes.** Attach the Handrail and a Handrail Spacer (63) to the left Upright with two Handrail Bolts (1), two Handrail Washers (80), and two Handrail Star Washers (2) as shown. **Loosely thread the two Handrail Bolts; Do not tighten the Handrail Bolts yet.**

Hold the Right Handrail Spacer against the right Upright (38) and feed the excess Wire Harness (53) into the right Upright. **Make sure the right and left Handrails (4) are at the same height.** Attach the right Handrail and Handrail Spacer to the right Upright with two Handrail Bolts (1), two Handrail Washers (80), and two Handrail Star Washers (2). **Loosely thread the two Handrail Bolts; Do not tighten the Handrail Bolts yet. Be careful not to pinch the Wire Harness (53).** Remove the tie from the Wire Harness and the right Handrail.

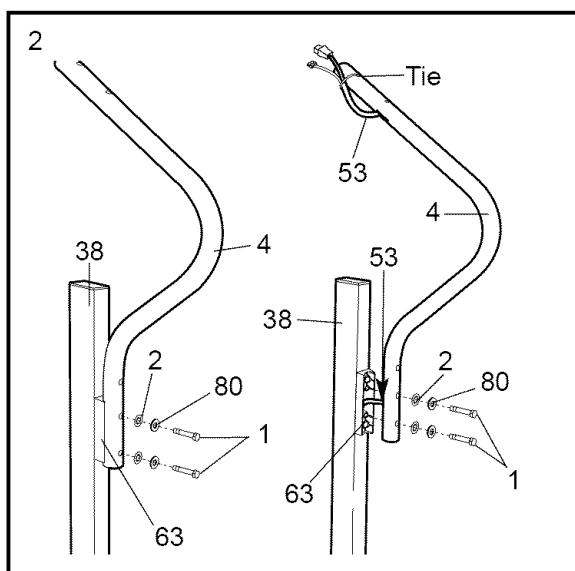

3. Hold the Console Base (87) near the right Handrail (4).

Make a loop with the indicated plastic tie and insert the two Wires (53) through the loop. Pull out only enough Wire to connect the Wires to the two connectors in the Console Base (87). **Important: Make sure that the Wires are fully inserted. WARNING: Do not disconnect or connect the Wires while the treadmill power cord is plugged in.**

Refer drawing 3a. Set the Console Base (87) on the Handrails (4). Thread four Console Screws (3) into the Handrails and the Console Base. After all four Screws have been started, **tighten the Screws until they are snug; do not overtighten the Screws.**

Feed the excess Wire Harness (53) into the upper end of the right Handrail (4). Pull the plastic tie tight and cut off the end.

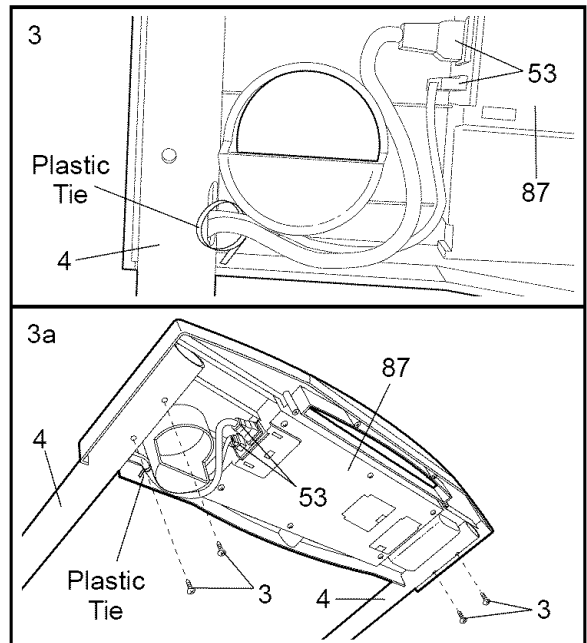

4. Attach the Storage Latch (16) to the left Upright (38) with two Latch Screws (14). Note: If there are four holes in the left Upright, use the two indicated holes. **Be careful not to overtighten the Screws.**

Refer to step 2. Tighten the four Handrail Bolts (1).

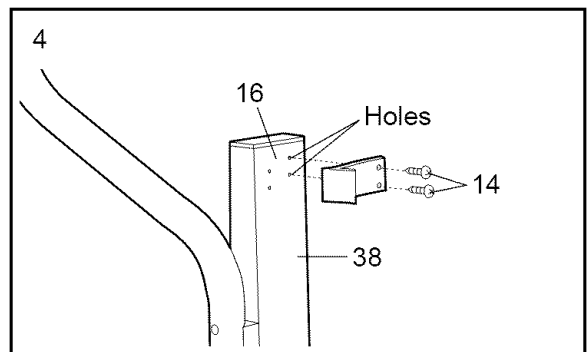

5. Loosely thread the bottom two Rack Screws (14) into the Upright (38) first. Then, loosely thread the other four Screws and then go back and tighten all of the Screws.

Set a 3-lb. Weight (not shown) on the bottom hanger on the Weight Rack (15), a 2-lb. Weight on the middle hanger, and a 1-lb. Weight on the top hanger.

Attach the other Weight Rack and Weights (not shown) to the left Upright in the same way.

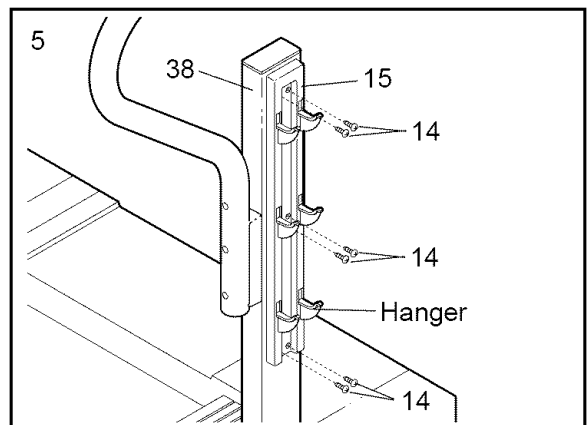

6. **Make sure that all parts are tightened before you use the treadmill.** To protect the floor or carpet, place a mat under the treadmill.

OPERATION AND ADJUSTMENT

THE PERFORMANT LUBE™ WALKING BELT

Your treadmill features a walking belt coated with PERFORMANT LUBE™, a high-performance lubricant. **IMPORTANT: Never apply silicone spray or other substances to the walking belt or the walking platform. Such substances will deteriorate the walking belt and cause excessive wear.**

HOW TO PLUG IN THE POWER CORD

⚠ DANGER: Improper connection of the equipment-grounding conductor can result in an increased risk of electric shock. Check with a qualified electrician or serviceman if you are in doubt as to whether the product is properly grounded. Do not modify the plug provided with the product—if it will not fit the outlet, have a proper outlet installed by a qualified electrician.

Your treadmill, like any other type of sophisticated electronic equipment, can be seriously damaged by sudden voltage changes in your home's power. Voltage surges, spikes, and noise interference can result from weather conditions or from other appliances being turned on or off. **To decrease the possibility of your treadmill being damaged, always use a surge suppressor with your treadmill (see drawing 1 at the right).**

To purchase a surge suppressor, see your local WESLO dealer or call toll-free 1-800-999-3756 and order part number 146148. Use only a single-outlet surge suppressor that is UL 1449 listed as a transient voltage surge suppressor (TVSS). The surge suppressor must have a UL suppressed voltage rating of 400 volts or less and a minimum surge dissipation of 450 joules. The surge suppressor must be electrically rated for 120 volts AC and 15 amps.

This product must be grounded. If it should malfunction or break down, grounding provides a path of least resistance for electric current to reduce the risk of electric shock. This product is equipped with a cord having an equipment-grounding conductor and a grounding plug. **Plug the power cord into a surge suppressor, and plug the surge suppressor into an appropriate outlet that is properly installed and**

grounded in accordance with all local codes and ordinances. Important: The treadmill is not compatible with GFCI-equipped outlets.

This product is for use on a nominal 120-volt circuit, and has a grounding plug that looks like the plug illustrated in drawing 1 below. A temporary adapter that looks like the adapter illustrated in drawing 2 may be used to connect the surge suppressor to a 2-pole receptacle as shown in drawing 2 if a properly grounded outlet is not available.

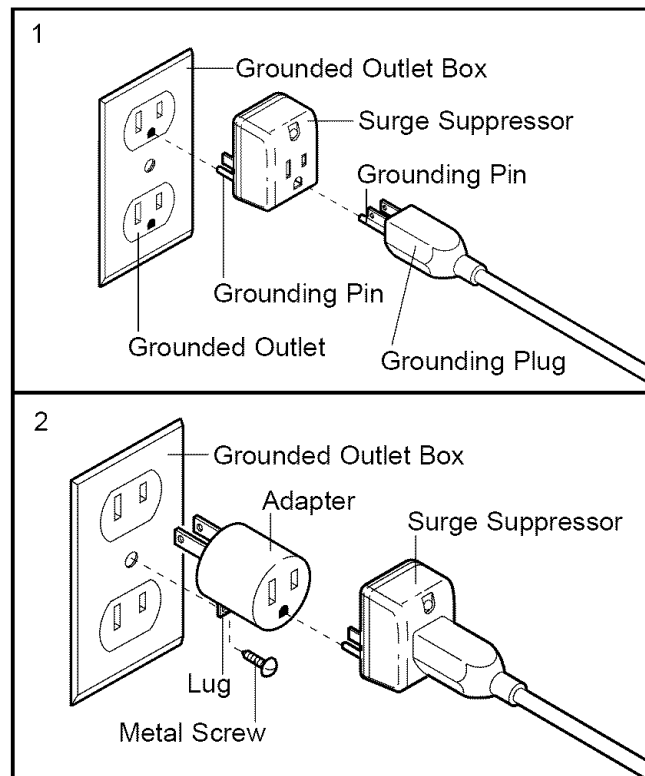

The temporary adapter should be used only until a properly grounded outlet (drawing 1) can be installed by a qualified electrician.

The green-colored rigid ear, lug, or the like extending from the adapter must be connected to a permanent ground such as a properly grounded outlet box cover. Whenever the adapter is used it must be held in place by a metal screw. **Some 2-pole receptacle outlet box covers are not grounded. Contact a qualified electrician to determine if the outlet box cover is grounded before using an adapter.**

DIAGRAM OF THE CONSOLE

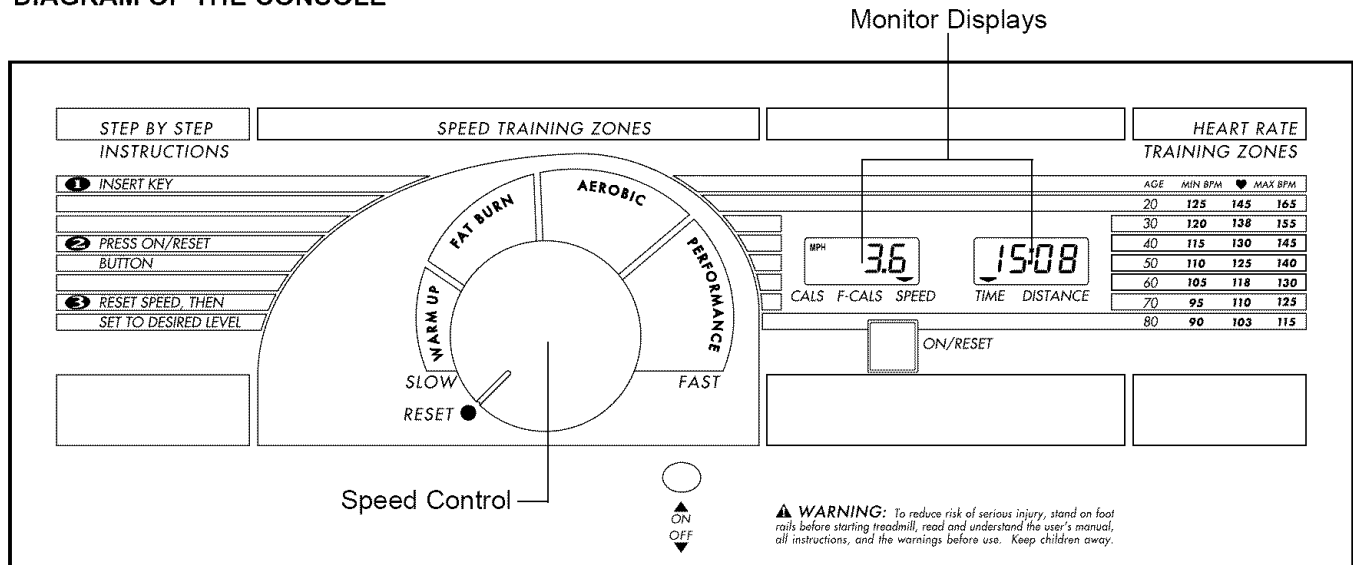

If there is a thin sheet of clear plastic on the console, remove it.

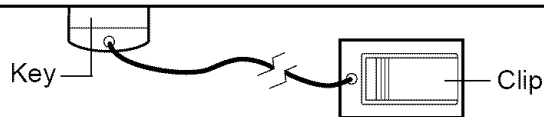

CAUTION: Before operating the console, read the following precautions.

- Do not stand on the walking belt when turning on the power.
- Always wear the clip (see the drawing above) while operating the treadmill. When the key is removed from the console, the walking belt will stop.
- Adjust the speed in small increments.
- The training zones marked around the speed control are general guidelines only. See page 14 for more information.
- To reduce the possibility of electric shock, keep the console dry. Avoid spilling liquids on the console and use only a sealable water bottle.

BATTERY INSTALLATION

The console requires two "AA" batteries (not included). Alkaline batteries are recommended. To install batteries, open the battery cover as shown at the right. Press two batteries into the battery compartment, with

the negative (-) ends of the batteries touching the springs. Close the battery cover, push up on the tab, and then push the tab forward as shown. Be sure that the tab locks into place.

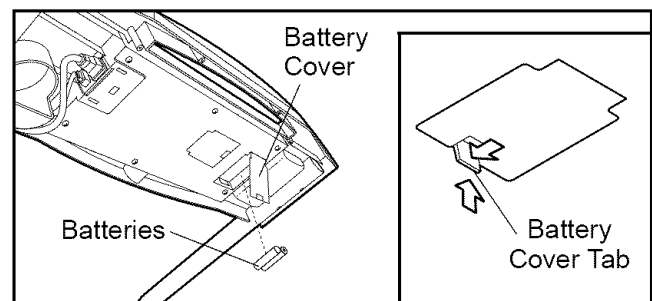

STEP-BY-STEP CONSOLE OPERATION

Before operating the console, make sure that the power cord is properly plugged in. (See HOW TO PLUG IN THE POWER CORD on page 7.)

Stand on the foot rails of the treadmill. Find the clip attached to the key, and slide the clip onto the waistband of your clothing. Next, insert the key into the console. **Test the clip by carefully taking a few steps backward until the key is pulled from the console. If the key is not pulled from the console, adjust the position of the clip as needed.**

Follow the steps on page 9 to operate the console.

1 Insert the key fully into the power switch.

Inserting the key will not turn on the displays. The displays will turn on when the ON/RESET button is pressed or when the walking belt is started. Note: If you just installed batteries, the displays will already be on.

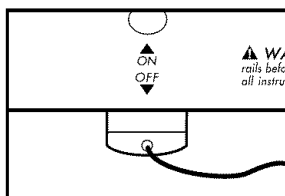

2 Reset the speed control and start the walking belt.

Turn the speed control to the RESET position. **Note: Each time the walking belt is stopped, the speed control must be turned to the RESET position**

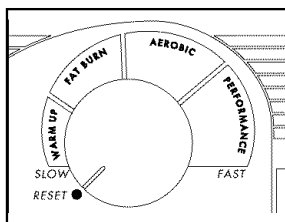

before the walking belt can be restarted. Next, slowly turn the speed control until the walking belt begins to move at slow speed. Carefully step onto the walking belt and begin exercising. Change the speed of the walking belt as desired by turning the speed control.

To stop the walking belt, step onto the foot rails and turn the speed control to the RESET position.

3 Follow your progress with the monitor modes

When the power is turned on, the console will scan through five modes repeatedly. Flashing mode indicators will show which mode is currently displayed. The modes are described below.

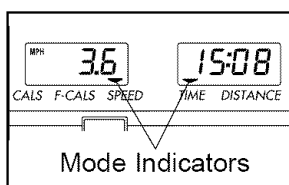

- **Calories (CALs)**—This mode shows the approximate number of calories you have burned.
- **Fat Calories (F CALs)**—This mode shows the approximate number of fat calories you have burned. (See **FAT BURNING** on page 14.)
- **Speed**—This mode shows your speed, in miles per hour.
- **Time**—This mode shows the elapsed time. Note: If you stop exercising for ten seconds or longer, the time mode will pause.

- **Distance**—This mode shows the total number of miles you have walked or run.

If desired, the displays can be reset by pressing the ON/RESET button.

4 When you are finished exercising, stop the walking belt and remove the key.

Step onto the foot rails, stop the walking belt, and remove the key from the console. The displays will turn off about six minutes after the key is removed. **Note: The displays will automatically turn off in order to conserve the batteries any time that the walking belt is stopped and the ON/RESET button is not pressed for six minutes.**

HOW TO CHANGE THE INCLINE OF THE TREADMILL

To vary the intensity of your exercise, the incline of the treadmill can be changed. There are four incline levels. **Before changing the incline, remove the key and unplug the power cord.** Next, fold the treadmill to the storage position (see **HOW TO FOLD THE TREADMILL FOR STORAGE** on page 10).

To change the incline, first remove the incline pin from the right incline leg as shown below. Adjust the incline leg to the desired height and fully reinsert the incline pin. Make sure that the incline pin is in the “locked” position shown in the inset drawing. Adjust the left incline leg in the same way. **Make sure that both incline pins are inserted from the direction shown.**

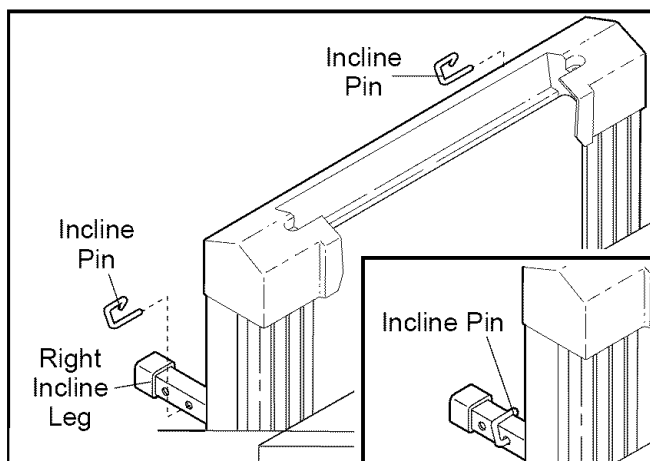

CAUTION: Before using the treadmill, make sure that both incline pins are fully inserted at the same height. Do not use the treadmill with the incline pins removed. After you have adjusted the incline legs, lower the treadmill (see **HOW TO LOWER THE TREADMILL FOR USE** on page 11).

HANDRAIL HEIGHT ADJUSTMENT

The Handrails (4) can be adjusted to either of two heights. **Before adjusting the Handrails, remove the key and unplug the power cord.**

Remove the four Console Screws (3). While a second person lifts the Console Base (87), remove the Handrail Bolts (1), Handrail Washers (80), Handrail Star Washers (2) and Handrail Spacer (63). Raise or lower the Handrails (4) to the desired height, being careful not to damage the Wire Harness (53). Reattach the Handrails and Handrail Spacers with the Handrail Bolts, Handrail Washers, and Handrail Star Washers. **Important: If you are 5' 8" or taller, use the lower two holes in the Handrail; if you are shorter than 5' 8", use the upper two holes. Make sure that both Handrails are at the same height. Do not tighten the Handrail Bolts yet. Always attach each Handrail with two Handrail Bolts.** Reattach the Console Base (87) (see assembly step 3 on page 6). Then, tighten the four Handrail Bolts.

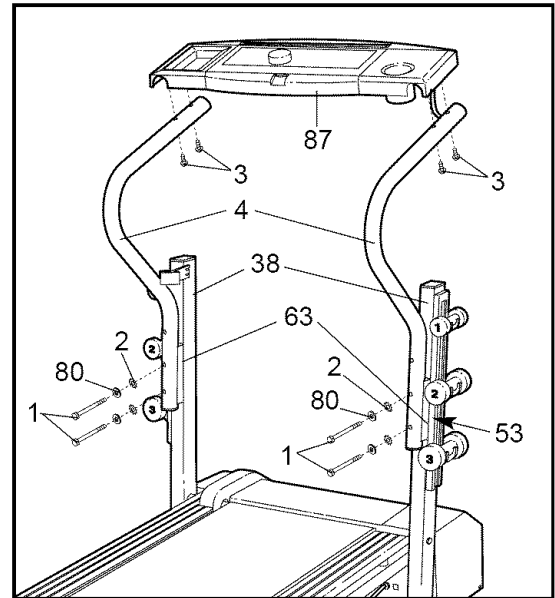

HOW TO FOLD AND MOVE THE TREADMILL

HOW TO FOLD THE TREADMILL FOR STORAGE

Before folding the treadmill, unplug the power cord. **CAUTION: You must be able to safely lift 45 pounds (20 kg) in order to raise, lower or move the treadmill.**

1. Hold the treadmill with your hands in the locations shown at the right. **To decrease the possibility of injury, bend your legs and keep your back straight. As you raise the treadmill, make sure to lift with your legs rather than your back.** Raise the treadmill about halfway to the vertical position.
2. Move your right hand to the position shown and hold the treadmill firmly. Using your left thumb, press the storage latch and hold it. Pivot the treadmill until the frame and foot rail are past the storage latch. Close the storage latch over the catch. **Make sure that the storage latch is fully engaged over the catch.**

To protect the floor or carpet from damage, place a mat under the treadmill. Keep the treadmill out of direct sunlight. Do not leave the treadmill in the storage position in temperatures above 85° Fahrenheit.

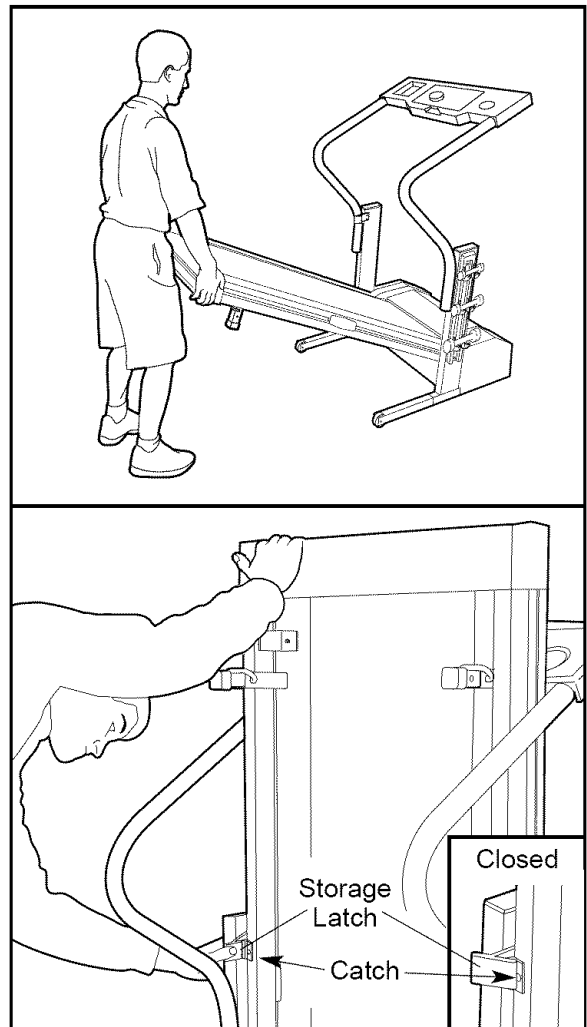

HOW TO MOVE THE TREADMILL

Before moving the treadmill, convert the treadmill to the storage position as described above. **Make sure that the storage latch is locked fully over the catch.**

1. Remove the weights from the weight racks.
2. Hold the upper ends of the handrails. Place one foot on one of the wheels as shown.
3. Tilt the treadmill back until it rolls freely on the wheels. Carefully move the treadmill to the desired location. **To reduce the risk of injury, use extreme caution while moving the treadmill. Do not attempt to move the treadmill over an uneven surface.**
4. Place one foot on the base, and carefully lower the treadmill until it is resting in the storage position.

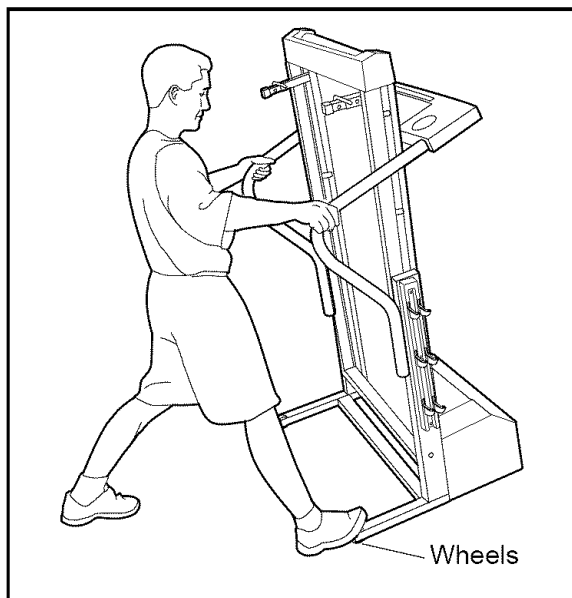

HOW TO LOWER THE TREADMILL FOR USE

1. Hold the upper end of the treadmill with your right hand as shown. Using your left thumb, press the storage latch and hold it. Pivot the treadmill until the frame and foot rail are past the storage latch.
2. Hold the treadmill firmly with both hands, and lower the treadmill to the floor. **Do not drop the treadmill frame to the floor. To decrease the possibility of injury, bend your legs and keep your back straight.**

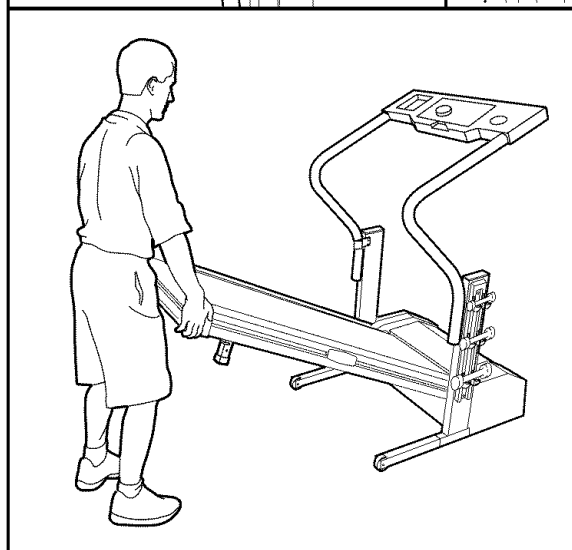
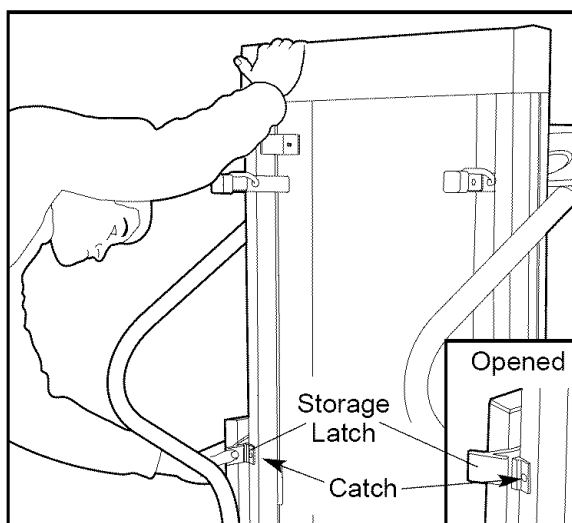

MAINTENANCE AND TROUBLE-SHOOTING

Most treadmill problems can be solved by following the steps below. Find the symptom that applies, and follow the steps listed. If further assistance is needed, please call our Customer Service Department toll-free at 1-800-999-3756, Monday through Friday, 6 a.m. until 6 p.m. Mountain Time (excluding holidays).

PROBLEM: The power does not turn on

- SOLUTION:**
- a. Make sure that the power cord is plugged into a surge suppressor, and that the surge suppressor is plugged into a properly grounded outlet (see page 7). Use only a single-outlet surge suppressor that is UL 1449 listed as a transient voltage surge suppressor (TVSS). The surge suppressor must have a UL suppressed voltage rating of 400 volts or less and a minimum surge dissipation of 450 joules. The surge suppressor must be electrically rated for 120 volts AC and 15 amps. Important: The treadmill is not compatible with GFCI-equipped outlets.
 - b. After the power cord has been plugged in, make sure that the key is fully inserted into the console.
 - c. Check the circuit breaker located on the treadmill frame near the power cord. If the switch protrudes as shown, the circuit breaker has tripped. To reset the circuit breaker, wait for five minutes and then press the switch back in.

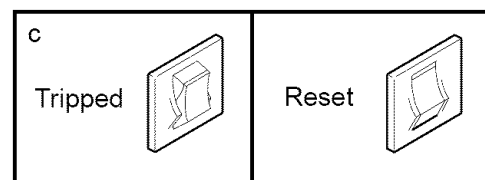

PROBLEM: The power turns off during use

- SOLUTION:**
- a. Check the circuit breaker located on the treadmill frame near the power cord (see the drawing above). If the circuit breaker has tripped, wait for five minutes and then press the switch back in.
 - b. Make sure that the power cord is plugged in.
 - c. Remove the key from the console. Reinsert the key fully into the console.
 - d. If the treadmill still will not run, please call our Customer Service Department, toll-free.

PROBLEM: The displays of the console do not function properly

- SOLUTION:**
- a. Check the batteries in the console. If the batteries need to be replaced, see “BATTERY INSTALLATION” on page 8. Most problems are the result of drained batteries.
 - b. Remove the screws from the hood, and carefully remove the hood. Locate the Reed Switch (13) and the Magnet (88) on the left side of the Pulley (75). Turn the Pulley until the Magnet is aligned with the Reed Switch. **Make sure that there is a gap of about 1/8” between the Magnet and the Reed Switch.** If necessary, loosen the Screw (31) and move the Reed Switch slightly. Retighten the Screw. Re-attach the hood, and run the treadmill for a few minutes to check for a correct speed reading.

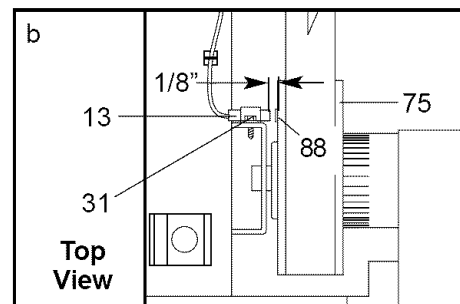

PROBLEM: The walking belt slows when walked on

SOLUTION: a. Use only a single-outlet surge suppressor that is UL 1449 listed as a transient voltage surge suppressor (TVSS). The surge suppressor must have a UL suppressed voltage rating of 400 volts or less and a minimum surge dissipation of 450 joules. The surge suppressor must be electrically rated for 120 volts AC and 15 amps.

b. If the walking belt is overtightened, treadmill performance may decrease and the walking belt may become damaged. Remove the key and **UNPLUG THE POWER CORD**. Using the allen wrench, turn both rear roller bolts counterclockwise 1/4 of a turn. When the walking belt is properly tightened, you should be able to lift each side of the walking belt 2 to 3 inches off the walking platform. Be careful to keep the walking belt centered. Plug in the power cord, insert the key, and run the treadmill for a few minutes. Repeat until the walking belt is properly tightened.

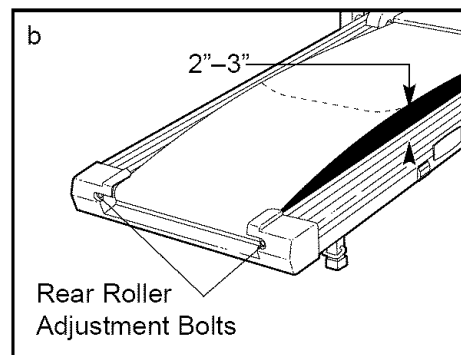

c. If the walking belt still slows when walked on, please call our Customer Service Department, toll-free.

PROBLEM: The walking belt is off-center or slips when walked on

SOLUTION: a. **If the walking belt has shifted to the left**, first remove the key and **UNPLUG THE POWER CORD**. Using the allen wrench, turn the left rear roller bolt clockwise 1/2 of a turn. Be careful not to overtighten the walking belt. **If the walking belt has shifted to the right**, turn the left rear roller bolt counterclockwise 1/2 of a turn. Plug in the power cord, insert the key and run the treadmill for a few minutes. Repeat until the walking belt is centered.

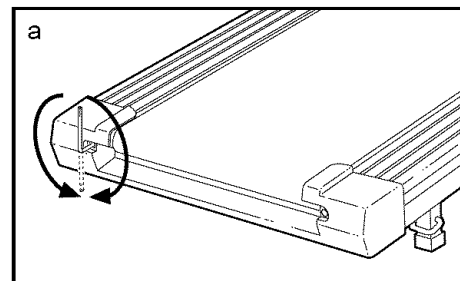

b. If the walking belt slips when walked on, first remove the key and **UNPLUG THE POWER CORD**. Using the allen wrench, turn both rear roller bolts clockwise, 1/4 of a turn. When the walking belt is correctly tightened, you should be able to lift each side of the walking belt 3 to 4 inches off the walking platform. Be careful to keep the walking belt centered. Plug in the power cord, insert the key and carefully walk on the treadmill for a few minutes. Repeat until the walking belt is properly tightened.

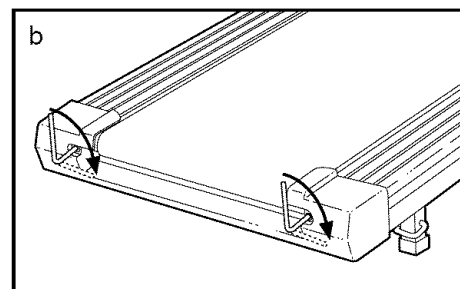

CONDITIONING GUIDELINES

⚠ WARNING: Before beginning this or any exercise program, consult your physician. This is especially important for individuals over the age of 35 or individuals with pre-existing health problems.

The following guidelines will help you to plan your exercise program. For more detailed exercise information, obtain a reputable book or consult your physician.

EXERCISE INTENSITY

Whether your goal is to burn fat or to strengthen your cardiovascular system, the key to achieving the desired results is to exercise with the proper intensity. The proper intensity level can be found by using your heart rate as a guide. The chart below shows recommended heart rates for fat burning and aerobic exercise.

AGE	MIN BPM		MAX BPM
	Fat Burn	Max Burn	Aerobic
20	125	145	165
30	120	138	155
40	115	130	145
50	110	125	140
60	105	118	130
70	95	110	125
80	90	103	115

To find the proper heart rate for you, first find your age on the left side of the chart (ages are rounded off to the nearest ten years). Next, find the three numbers to the right of your age. The three numbers are your "training zone." The lower two numbers are recommended heart rates for fat burning; the highest number is the recommended heart rate for aerobic exercise.

Fat Burning

To burn fat effectively, you must exercise at a relatively low intensity level for a sustained period of time. During the first few minutes of exercise, your body uses easily accessible carbohydrate calories for energy. Only after the first few minutes does your body begin to use stored fat calories for energy. If your goal is to burn fat, adjust the speed of the treadmill until your heart rate is near one of the lower two numbers in your training zone. It may also be helpful to set the

speed control on the console to FAT BURN to help you maintain the proper intensity level. (See page 9.)

Aerobic Exercise

If your goal is to strengthen your cardiovascular system, your exercise must be "aerobic." Aerobic exercise is activity that requires large amounts of oxygen for prolonged periods of time. This increases the demand on the heart to pump blood to the muscles, and on the lungs to oxygenate the blood. For aerobic exercise, adjust the speed of the treadmill until your heart rate is near the highest number in your training zone. It may also be helpful to set the speed control on the console to AEROBIC to help you maintain the proper intensity level. (See page 9.)

High Performance Athletic Conditioning

If your goal is high performance athletic conditioning, set the speed control on the console to PERFORMANCE to help you maintain the proper intensity level. (See page 9.) Note: During the first few weeks of your exercise program, keep your heart rate near the low end of your training zone.

HOW TO MEASURE YOUR HEART RATE

To measure your heart rate, stop exercising and place two fingers on your wrist as shown. Take a six-second heartbeat count, and multiply the result by

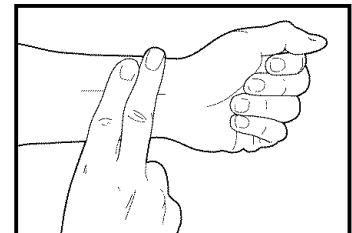

ten to find your heart rate. (A six-second count is used because your heart rate drops quickly when you stop exercising.) If your heart rate is too high or too low, adjust the speed or incline of the treadmill accordingly.

USING THE HAND WEIGHTS

The included hand weights let you add upper body exercise to your workouts. As you walk on the treadmill, hold the 1-lb. weights at your sides or press the weights above your head. To increase the intensity of your exercise, use the 2-lb. or 3-lb. weights. **WARNING: Use the hand weights only at walking speeds. Using weights and not holding the handrails may compromise your ability to maintain your balance. Exercises using weights should be attempted only by experienced users.**

WORKOUT GUIDELINES

Each workout should include the following three parts:

A Warm-up

Start each workout with 5 to 10 minutes of stretching and light exercise. A proper warm-up increases your body temperature, heart rate, and circulation in preparation for exercise.

Training Zone Exercise

After warming up, increase the intensity of your exercise until your pulse is in your training zone for 20 to 60 minutes. (During the first few weeks of your exercise program, do not keep your pulse in your training

zone for longer than 20 minutes.) Breathe regularly and deeply as you exercise—never hold your breath.

A Cool-down

Finish each workout with 5 to 10 minutes of stretching to cool down. This will increase the flexibility of your muscles and will help prevent post-exercise problems.

EXERCISE FREQUENCY

To maintain or improve your condition, complete three workouts each week, with at least one day of rest between workouts. After a few months, you may complete up to five workouts each week if desired. The key to success is to make exercise a regular and enjoyable part of your everyday life.

SUGGESTED STRETCHES

The correct form for several basic stretches is shown in the drawings below. Move slowly as you stretch—never bounce.

1. Toe Touch Stretch

Stand with your knees bent slightly and slowly bend forward from your hips. Allow your back and shoulders to relax as you reach down toward your toes as far as possible. Hold for 15 counts, then relax. Repeat 3 times. Stretches: Hamstrings, back of knees and back.

2. Hamstring Stretch

Sit with one leg extended. Bring the sole of the opposite foot toward you and rest it against the inner thigh of your extended leg. Reach toward your toes as far as possible. Hold for 15 counts, then relax. Repeat 3 times for both legs. Stretches: Hamstrings, lower back and groin.

3. Calf/Achilles Stretch

With one leg in front of the other, reach forward and place your hands against a wall. Keep your back leg straight and your back foot flat on the floor. Bend your front leg, lean forward and move your hips toward the wall. Hold for 15 counts, then relax. Repeat 3 times for both legs. To cause further stretching of the achilles tendons, bend your back leg as well. Stretches: Calves, achilles tendons and ankles.

4. Quadriceps Stretch

With one hand against a wall for balance, reach back and grasp one foot with your other hand. Bring your heel as close to your buttocks as possible. Hold for 15 counts, then relax. Repeat 3 times for both legs. Stretches: Quadriceps and hip muscles.

5. Inner Thigh Stretch

Sit with the soles of your feet together and your knees outward. Pull your feet toward your groin area as far as possible. Hold for 15 counts, then relax. Repeat 3 times. Stretches: Quadriceps and hip muscles.

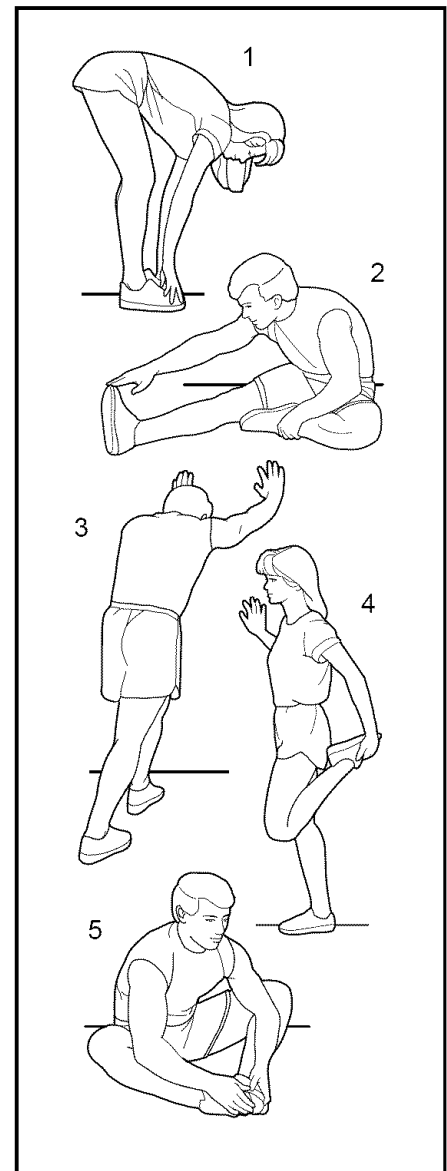

REMOVE THIS EXPLODED DRAWING AND PART LIST FROM THE MANUAL

Save this EXPLODED DRAWING and PART LIST for future reference.

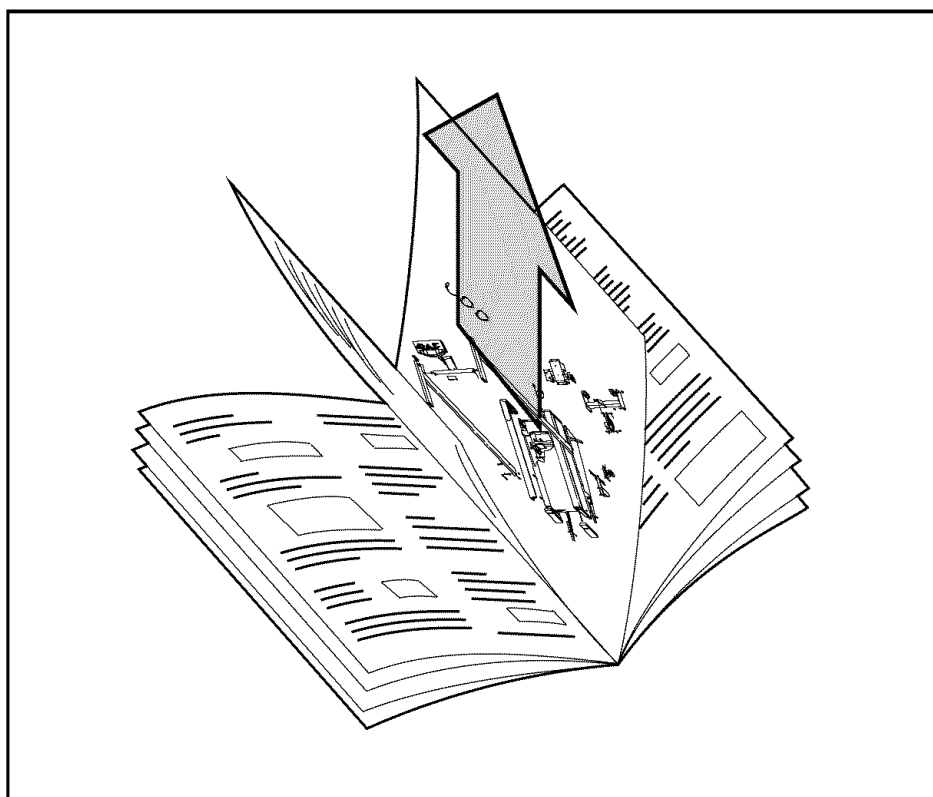

Note: Specifications are subject to change without notice. For information about ordering replacement parts, see the back cover of the User's Manual.

PART LIST—Model No. WLTL29011

R0701A

Key No.	Qty.	Description	Key No.	Qty.	Description
1	4	Handrail Bolt	49	2	Upright Endcap
2	4	Handrail Star Washer	50	1	Right Foot Rail
3	4	Console Screw	51	4	Platform Screw
4	2	Handrail	52	1	Front Roller Adj. Bolt
5	6	Console Insert Screw	53	1	Wire Harness
6	1	Key/Clip	54	6	Isolator Screw
7	1	Right Frame Guide	55	2	Front Isolator
8	2	Incline Leg	56	2	2-lb. Hand Weight
9	1	Speed Potentiometer	57	1	Choke
10	1	Speed Control	58	2	Belt Guide
11*	1	Console Assembly	59	2	3-lb. Hand Weight
12	2	Battery Cover	60	2	Isolator
13	1	Reed Switch	61	2	Wheel Nut
14	17	Rack Screw/Latch Screw	62	1	Frame Spacer (Left)
15	2	Weight Rack	63	2	Handrail Spacer
16	1	Storage Latch	64	2	Incline Pin
17*	2	Extension Leg Assembly	65	2	Endcap Washer
18	1	Motor Belt	66	1	Latch Catch
19	1	Motor Tension Bolt	67	1	Walking Belt
20	1	Motor Tension Washer	68	1	Wire Tie
21	1	Tension Star Washer	69	4	Wire Tie Clamp
22	1	Motor Pivot Nut	70	1	Frame Spacer (Right)
23	1	Motor/Pulley/Flywheel/Fan	71	1	Walking Platform
24	1	Pulley/Flywheel/Fan	72	2	Endcap
25	1	Motor	73	4	Isolator Spacer
26	1	Motor Pivot Bolt	74	1	Sensor Clip
27	5	8" Cable Tie	75	1	Front Roller/Pulley
28	15	3/4" Screw	76	4	Electronic Screw
29	1	Hood	77	1	Ground Wire
30	1	Hood Shield	78	2	Rear Roller Adj. Bolt
31	7	Small Screw	79	1	Rear Endcap
32	2	1-lb. Hand Weight	80	4	Handrail Washer
33	4	Base Leg Pad	81	1	Allen Wrench
34	1	Motor Belly Pan	82	1	Latch Decal
35	1	Controller	83	1	Rear Roller
36	2	Frame Pivot Bolt	84	1	Frame
37	2	Frame Pivot Washer	85	2	Rear Platform Screw
38	1	Upright Base	86	1	Left Foot Rail
39	2	Extension Leg Screw	87	1	Console Base
40	5	Roller Adj. Washer	88	1	Magnet
41	2	Wheel Bolt	89	1	Reed Switch
42	2	Wheel	#	1	4" White Wire, Male/Female
43	6	Incline Nut/Frame Pivot Nut	#	1	4" Blue Wire, Male/Female
44	2	Base Leg	#	1	User's Manual
45	1	Circuit Breaker			
46	1	Grommet			
47	1	Power Cord			
48	1	Motor Tension Nut			

* Includes all parts shown in the box
 Note: "#" indicates a non-illustrated part.

Specifications are subject to change without notice. See the back cover of the user's manual for information about ordering replacement parts.

EXPLODED DRAWING—Model No. WLTL29011

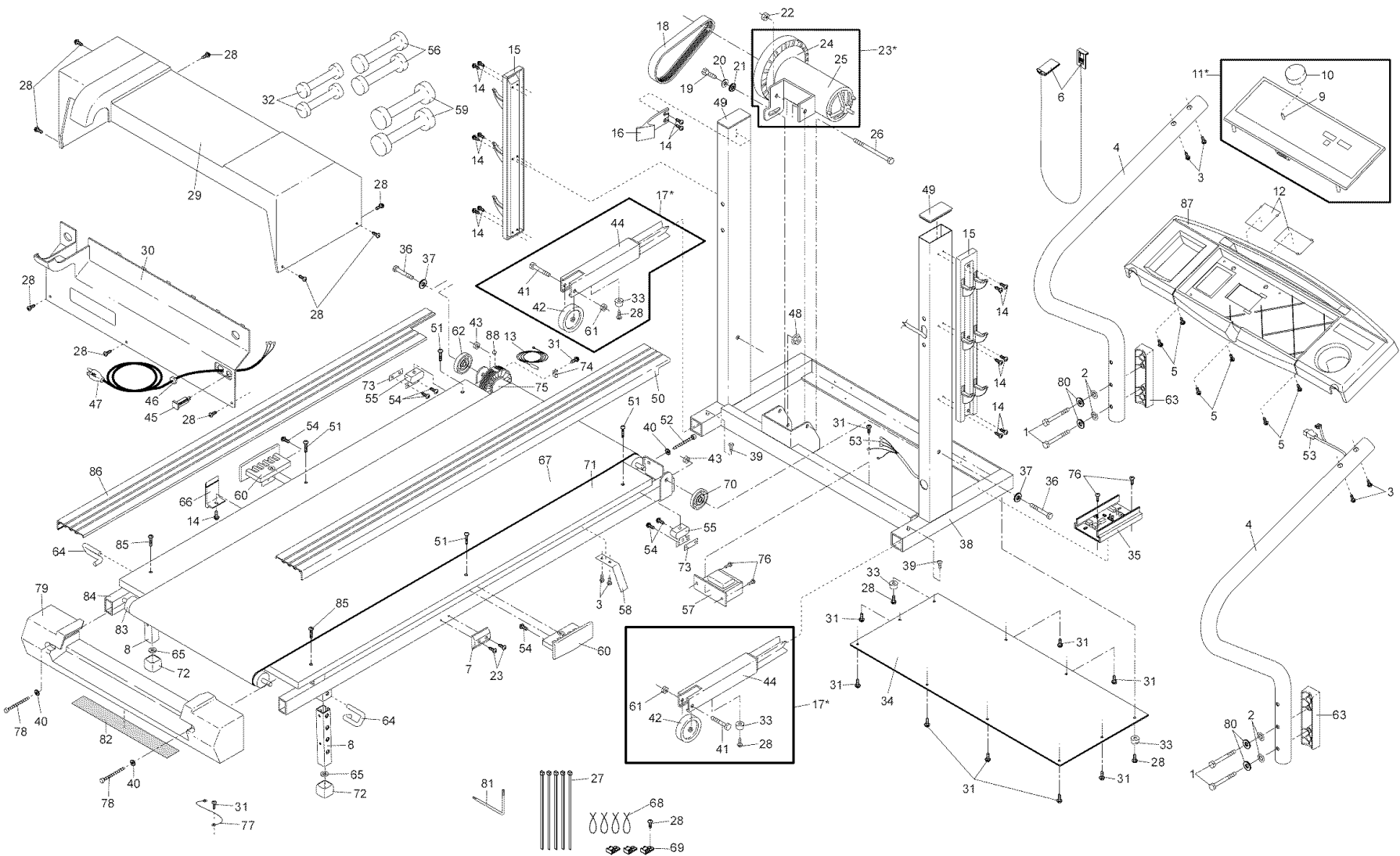

ORDERING REPLACEMENT PARTS

To order replacement parts, simply call our Customer Service Department toll-free at 1-800-999-3756, Monday through Friday, 6 a.m. until 6 p.m. Mountain Time (excluding holidays). To help us assist you, please be prepared to give the following information when calling:

- The MODEL NUMBER of the product (WLTL29011)
- The NAME of the product (WESLO CADENCE® 340 CS treadmill)
- The SERIAL NUMBER of the product (see the front cover of this manual)
- The KEY NUMBER and DESCRIPTION of the desired part(s) (see the PART LIST and the EXPLODED DRAWING in the center of this manual).

WESLO is a registered trademark of ICON Health & Fitness, Inc.

LIMITED WARRANTY

ICON Health & Fitness, Inc. (ICON), warrants this product to be free from defects in workmanship and material, under normal use and service conditions, for a period of ninety (90) days from the date of purchase. This warranty extends only to the original purchaser. ICON's obligation under this warranty is limited to replacing or repairing, at ICON's option, the product through one of its authorized service centers. All repairs for which warranty claims are made must be pre-authorized by ICON. This warranty does not extend to any product or damage to a product caused by or attributable to freight damage, abuse, misuse, improper or abnormal usage or repairs not provided by an ICON authorized service center, products used for commercial or rental purposes, or products used as store display models. No other warranty beyond that specifically set forth above is authorized by ICON.

ICON is not responsible or liable for indirect, special or consequential damages arising out of or in connection with the use or performance of the product or damages with respect to any economic loss, loss of property, loss of revenues or profits, loss of enjoyment or use, costs of removal, installation or other consequential damages of whatsoever nature. Some states do not allow the exclusion or limitation of incidental or consequential damages. Accordingly, the above limitation may not apply to you.

The warranty extended hereunder is in lieu of any and all other warranties and any implied warranties of merchantability or fitness for a particular purpose is limited in its scope and duration to the terms set forth herein. Some states do not allow limitations on how long an implied warranty lasts. Accordingly, the above limitation may not apply to you.

This warranty gives you specific legal rights. You may also have other rights which vary from state to state.

ICON HEALTH & FITNESS, INC., 1500 S. 1000 W., LOGAN, UT 84321-9813