

weslo®

Cadence 255 DR

Model No. WLTL211040

Serial No. _____

Write the serial number in the space above for future reference.

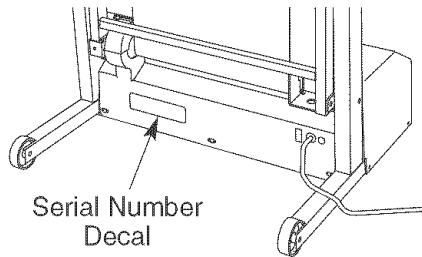

QUESTIONS?

If you have questions, or if there are missing parts, we will guarantee complete satisfaction through direct assistance from our factory.

TO AVOID DELAYS, PLEASE CALL DIRECT TO OUR TOLL-FREE CUSTOMER HOT LINE. The trained technicians on our Customer Hot Line will provide immediate assistance, free of charge to you.

CUSTOMER HOT LINE:
1-866-699-3756
Mon.-Fri., 6 a.m.-6 p.m. MST

CAUTION

Read all precautions and instructions in this manual before using this equipment. Save this manual for future reference.

USER'S MANUAL

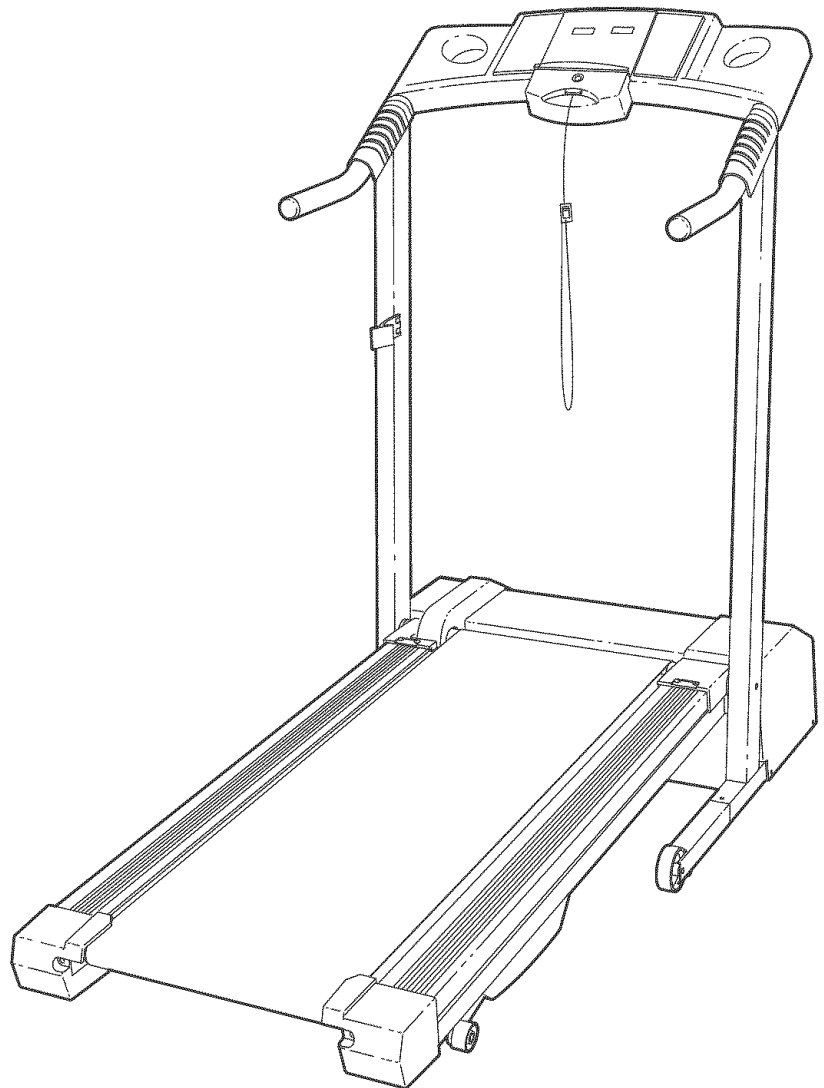

Visit our website at

www.weslo.com

new products, prizes,
fitness tips, and much more!

TABLE OF CONTENTS

IMPORTANT PRECAUTIONS	2
BEFORE YOU BEGIN	4
ASSEMBLY	5
OPERATION AND ADJUSTMENT	8
HOW TO FOLD AND MOVE THE TREADMILL	11
MAINTENANCE AND TROUBLESHOOTING	12
CONDITIONING GUIDELINES	14
ORDERING REPLACEMENT PARTS	Back Cover
LIMITED WARRANTY	Back Cover

Note: An EXPLODED DRAWING and a PART LIST are attached in the center of this manual.

IMPORTANT PRECAUTIONS

▲ WARNING: To reduce the risk of burns, fire, electric shock, or injury to persons, read the following important precautions and information before operating the treadmill.

1. It is the responsibility of the owner to ensure that all users of this treadmill are adequately informed of all warnings and precautions.
2. Use the treadmill only as described.
3. Place the treadmill on a level surface, with at least eight feet of clearance behind it and two feet on each side. Do not place the treadmill on any surface that blocks air openings. To protect the floor or carpet from damage, place a mat under the treadmill.
4. Keep the treadmill indoors, away from moisture and dust. Do not put the treadmill in a garage or covered patio, or near water.
5. Do not operate the treadmill where aerosol products are used or where oxygen is being administered.
6. Keep children under the age of 12 and pets away from the treadmill at all times.
7. The treadmill should not be used by persons weighing more than 250 pounds.
8. Never allow more than one person on the treadmill at a time.
9. Wear suitable exercise clothes when using the treadmill. Do not wear loose clothes that could become caught in the treadmill. Athletic support clothes are recommended for both men and women. *Always wear athletic shoes. Never use the treadmill with bare feet, wearing only stockings, or in sandals.*
10. When connecting the power cord (see page 8), plug the power cord into a surge suppressor (not included) and plug the surge suppressor into a grounded circuit capable of carrying 15 or more amps. No other appliance should be on the same circuit. Do not use an extension cord.
11. Use only a single-outlet surge suppressor that meets all of the specifications described on page 8. To purchase a surge suppressor, see your local WESLO dealer or call 1-866-699-3756 and order part number 146148, or see your local electronics store.
12. Failure to use a properly functioning surge suppressor could result in damage to the control system of the treadmill. If the control system is damaged, the walking belt may change speed or stop unexpectedly, which may result in a fall and serious injury.
13. Keep the power cord and the surge suppressor away from heated surfaces.
14. Never move the walking belt while the power is turned off. Do not operate the treadmill if the power cord or plug is damaged, or if the treadmill is not working properly. (See page 4 if the treadmill is not working properly.)
15. Never start the treadmill while you are standing on the walking belt. Always hold the handrails while using the treadmill.

16. The treadmill is capable of high speeds. Adjust the speed in small increments to avoid sudden jumps in speed.
17. Never leave the treadmill unattended while it is running. Always remove the key and unplug the power cord when the treadmill is not in use.
18. Do not attempt to raise, lower, or move the treadmill until it is properly assembled. (See ASSEMBLY on page 5, and HOW TO MOVE THE TREADMILL on page 11.) You must be able to safely lift 45 pounds (20 kg) to raise, lower, or move the treadmill.
19. Do not change the incline of the treadmill by placing objects under the treadmill.
20. When folding or moving the treadmill, make sure that the storage latch is fully closed.

21. Inspect and properly tighten all parts of the treadmill regularly.
22. Never drop or insert any object into any opening.
23. **DANGER:** Always unplug the power cord immediately after use, before cleaning the treadmill, and before performing the maintenance and adjustment procedures described in this manual. Never remove the motor hood unless instructed to do so by an authorized service representative. Servicing other than the procedures in this manual should be performed by an authorized service representative only.
24. This treadmill is intended for in-home use only. Do not use this treadmill in any commercial, rental, or institutional setting.

⚠ WARNING: Before beginning this or any exercise program, consult your physician. This is especially important for persons over the age of 35 or persons with pre-existing health problems. Read all instructions before using. ICON assumes no responsibility for personal injury or property damage sustained by or through the use of this product.

SAVE THESE INSTRUCTIONS

The decals shown have been placed on your treadmill. If a decal is missing, or if it is not legible, please call toll-free 1-866-699-3756 to order a free replacement decal. Apply the decal in the location shown. Note: The decals are not shown at actual size.

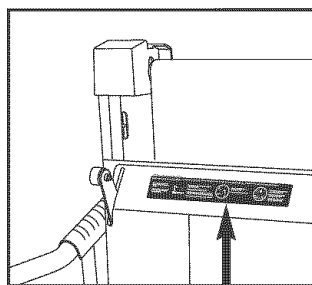
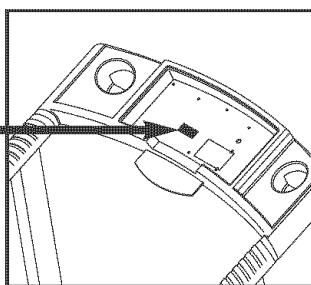
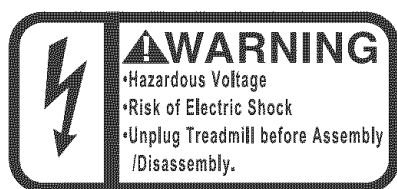

⚠ WARNING: Protect yourself and others from risk of serious injury. Read the user's manual and:

- Fully engage storage latch before treadmill is moved or stored.
- Reduce incline to lowest level before folding treadmill into storage position.
- Stand only on side rails when starting or stopping treadmill.
- Change speed in small increments.
- Hold handrails to prevent falling, and always wear the safety clip while operating treadmill.
- Stop if you feel faint, dizzy, or short of breath.
- Never allow children on or around treadmill.
- Remove key when not in use.
- Keep clothing, fingers, and hair away from moving belt.
- Never try to adjust or fix the belt while it is moving.
- Always wear athletic shoes while operating treadmill.





BEFORE YOU BEGIN

Thank you for selecting the WESLO® CADENCE 255 DR treadmill. The CADENCE 255 DR treadmill combines advanced technology with innovative design to let you enjoy an excellent form of cardiovascular exercise in the convenience and privacy of your home. And when you're not exercising, the unique CADENCE 255 DR treadmill can be folded up, requiring less than half the floor space of other treadmills.

For your benefit, read this manual carefully before using the treadmill. If you have questions after reading this manual, please call our Customer Service

Department toll-free at 1-866-699-3756, Monday through Friday, 6 a.m. until 6 p.m. Mountain Time (excluding holidays). To help us assist you, please note the product model number and serial number before calling. The model number of the treadmill is WLTL211040. The serial number can be found on a decal attached to the treadmill (see the front cover of this manual for the location).

Before reading further, please review the drawing below and familiarize yourself with the labeled parts.

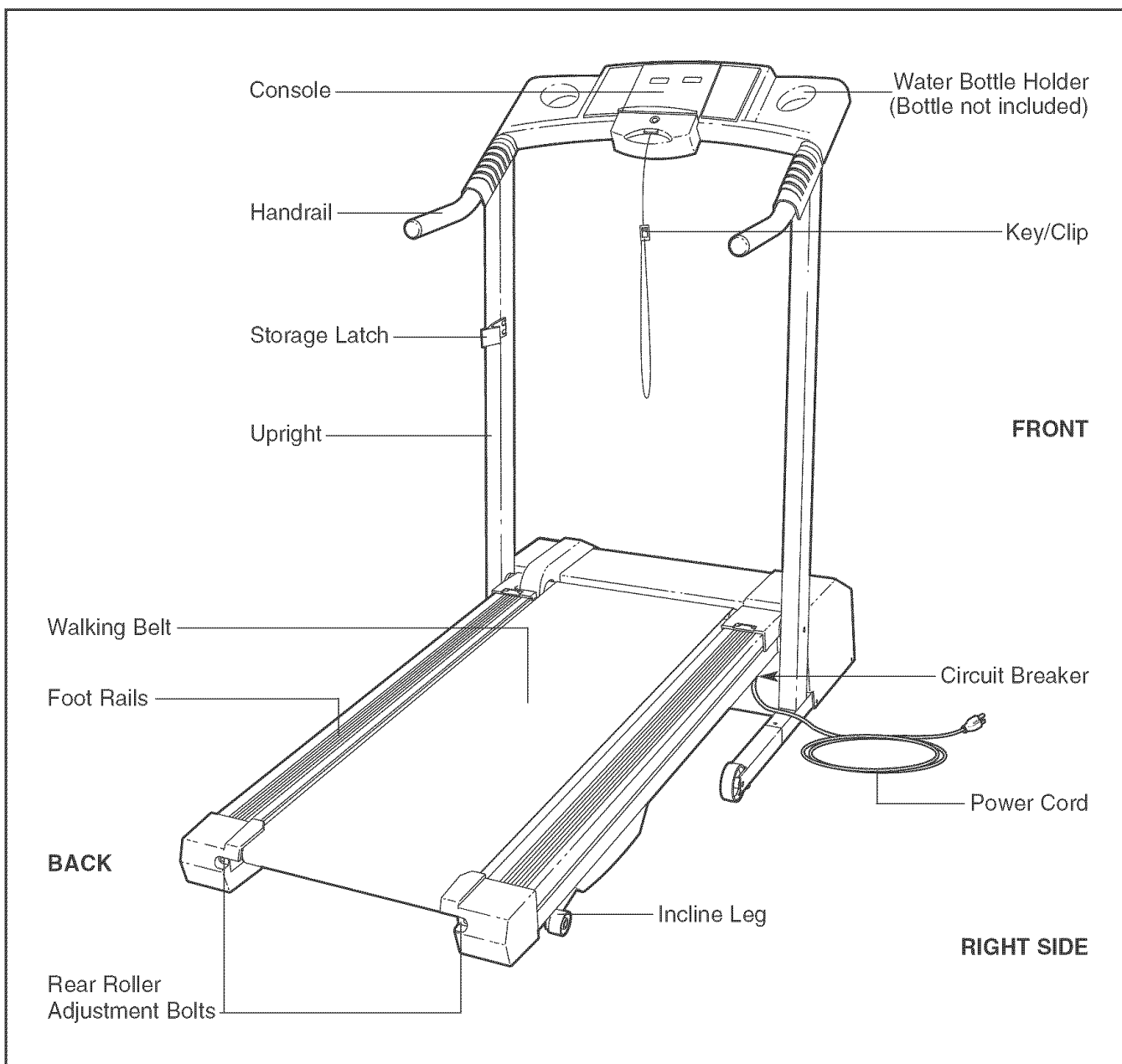

ASSEMBLY

Assembly requires two persons. Set the treadmill in a cleared area and remove all packing materials. Do not dispose of the packing materials until assembly is completed.

Note: The underside of the treadmill walking belt is coated with high-performance lubricant. During shipping, a small amount of lubricant may be transferred to the top of the walking belt or the shipping carton. This is a normal condition and does not affect treadmill performance. If there is lubricant on top of the walking belt, simply wipe off the lubricant with a soft cloth and a mild, non-abrasive cleaner.

Assembly requires the included allen wrenches  and your own phillips screwdriver , wire cutters , and needlenose pliers .

To identify small parts, use the **PART IDENTIFICATION CHART** attached in the center of this manual.

Note: If a part is not in the parts bag, first check to see if it has been pre-assembled.

1. Make sure that the power cord is unplugged.



With the help of a second person, carefully raise the Uprights (38) until the treadmill is in the position shown.

Cut the plastic tie (not shown) off the right Upright (38).

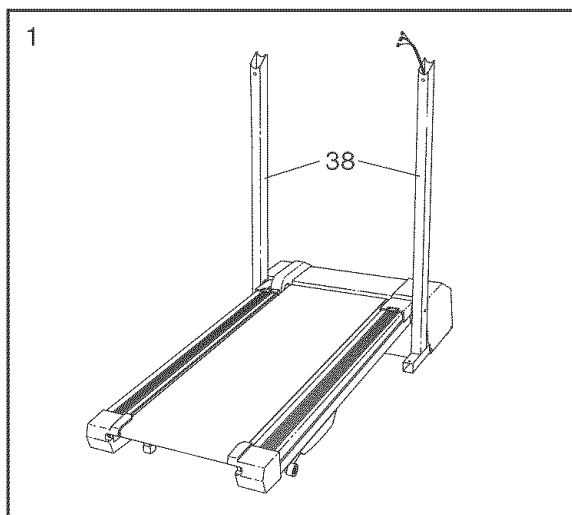

2. Insert one of the Extension Legs (15) into the treadmill as shown. Make sure that the Base Pad (33) is on the indicated side. Note: It may be helpful to tip the Uprights (38) in the direction shown by the arrow as you insert the Extension Leg.

Attach the Extension Leg (15) with an Extension Leg Screw (14). **Make sure to push on the head of the Extension Leg Screw while tightening it.**

Attach the other Extension Leg (15) in the same way.

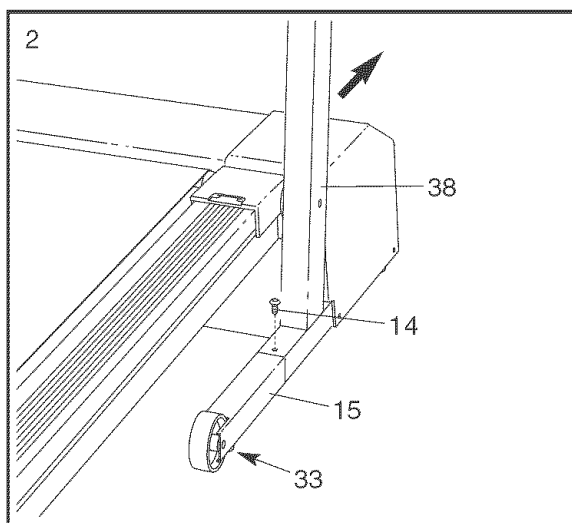

- If there are plastic ties in the brackets on the Handrails (4), remove the plastic ties. Hold one of the Handrails near the right Upright (38) as shown. Insert the Wire Harness (53) up through the bracket on the Handrail and out of the round hole in the side of the Handrail. If necessary, use needlenose pliers to pull the Wire Harness out of the hole. **Be careful not to damage the Wire Harness.**

Insert the brackets on the Handrails (4) into the upper ends of the Uprights (38).

Finger tighten four 1" Bolts (16) with Handrail Washers (40) into the Uprights (38) and the Handrails (4) as shown.

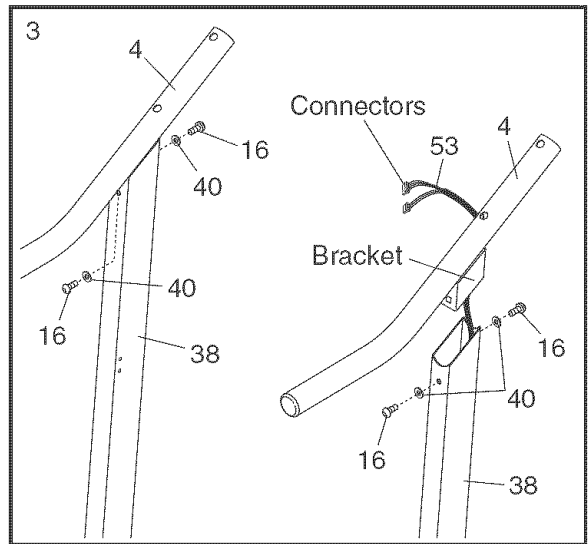

- Set the Console Base (87) on the Handrails (4). Thread four 3/4" Screws (5) into the Handrails and the Console Base. After you have started all four Screws, **tighten the Screws until they are snug; do not overtighten the Screws.** Note: It may be helpful to press down on the top of the Console Base above the Handrails as you tighten the Screws.

See step 3. Firmly tighten, but do not overtighten, the four 1" Bolts (16).

Insert the Wire Harness (53) through the two indicated plastic ties on the Console Base (87) and up through the hole in the Console Base as shown.

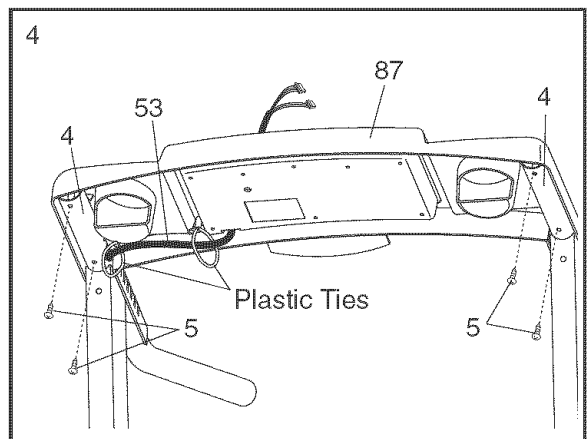

- Hold the Console (11) near the Console Base (87). **Touch the right Handrail (4) to discharge any static.**

Next, insert the Wire Harness (53) through the plastic tie labeled C in the drawing at the right.

Locate the two connectors on the Wire Harness (53). Plug the wider connector into the connector labeled A in the drawing at the right (see drawing 5b). **The connectors should slide together easily and snap into place.** If they do not, turn the connector on the Wire Harness and try again. Insert the other connector through the plastic tie labeled D; plug the connector into the connector labeled B (see drawing 5c). **IF THE CONNECTORS ARE NOT INSERTED PROPERLY, THE CONSOLE MAY BE DAMAGED WHEN THE POWER IS TURNED ON.**

See drawing 5a. Pull any slack in the Wire Harness (53) through the two ties. Make sure that the end of the Wire Harness indicated by the arrow is routed as shown. **Securely tighten the plastic ties around the Wire Harness.** Cut off the end of each plastic tie.

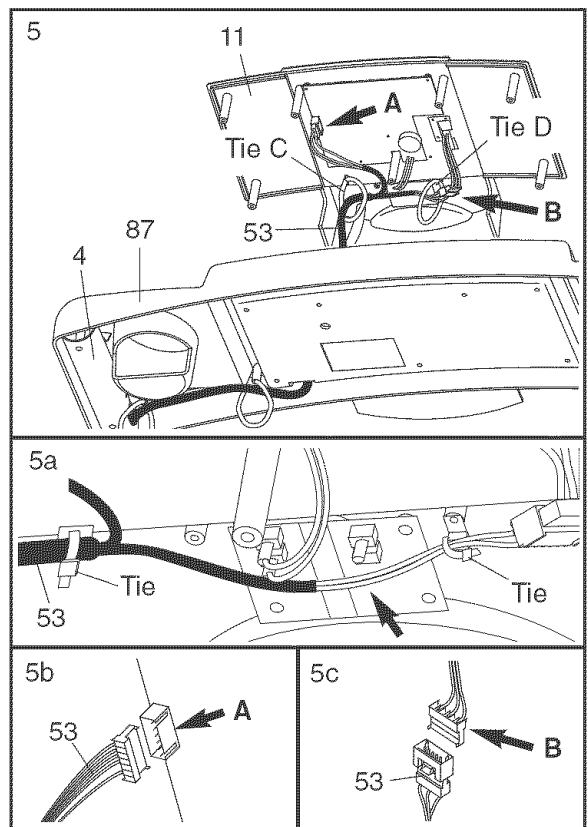

6. Set the Console (11) in the Console Base (87). **Make sure that no wires are pinched.** Insert as much of the Wire Harness (53) as possible down into the hole in the right Handrail (4). **Securely tighten the plastic tie nearest to the right Handrail.** Pull any excess Wire Harness between the plastic ties tight and tighten the other plastic tie. Cut off the ends of the plastic ties. Cover the Wire Harness with the Wire Cover (10), and route the Wire Harness out of the hole in the side of the Wire Cover. Attach the Wire Cover to the back of the Console Base with two 3/4" Screws (5). **Do not overtighten the Screws.**

Make sure that no wires are pinched before you attach the Console (11) to the Console Base (87). Tighten five 3/4" Screws (5) into the Console Base and the Console in the locations shown. **Note: No 3/4" Screw goes into the hole indicated by the arrow. Do not overtighten the Screws.**

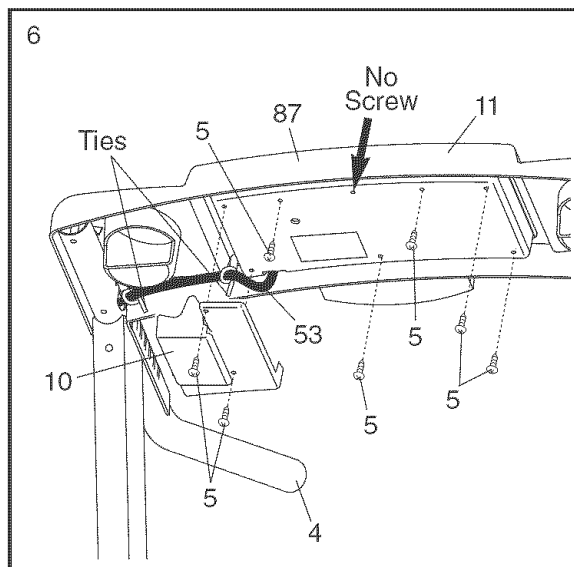

7. Attach the Storage Latch (66) to the left Upright (38) with two 3/4" Screws (5).

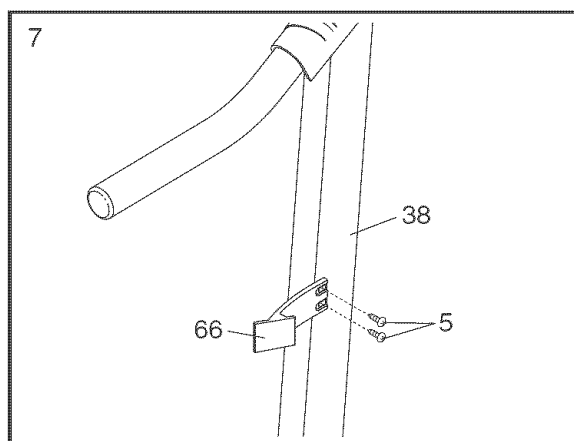

8. **Make sure that all parts used in assembly are properly tightened before you use the treadmill.** Keep the included allen wrench in a secure place. The allen wrench is used to adjust the walking belt (see page 13). To protect the floor or carpet, place a mat under the treadmill.

OPERATION AND ADJUSTMENT

THE PRE-LUBRICATED WALKING BELT

Your treadmill features a walking belt coated with high-performance lubricant. **IMPORTANT:** Never apply silicone spray or other substances to the walking belt or the walking platform. Such substances will deteriorate the walking belt and cause excessive wear.

HOW TO PLUG IN THE POWER CORD

⚠ DANGER: Improper connection of the equipment-grounding conductor can result in an increased risk of electric shock. Check with a qualified electrician or serviceman if you are in doubt as to whether the product is properly grounded. Do not modify the plug provided with the product—if it will not fit the outlet, have a proper outlet installed by a qualified electrician.

Your treadmill, like any other type of sophisticated electronic equipment, can be seriously damaged by sudden voltage changes in your home's power. Voltage surges, spikes, and noise interference can result from weather conditions or from other appliances being turned on or off. **To decrease the possibility of your treadmill being damaged, always use a surge suppressor with your treadmill (see drawing 1 at the right).** To purchase a surge suppressor, see your local WESLO dealer or call 1-866-699-3756 and order part number 146148, or see your local electronics store.

Use only a single-outlet surge suppressor that is UL 1449 listed as a transient voltage surge suppressor (TVSS). The surge suppressor must have a UL suppressed voltage rating of 400 volts or less and a minimum surge dissipation of 450 joules. The surge suppressor must be electrically rated for 120 volts AC and 15 amps. There must be a monitoring light on the surge suppressor to indicate whether it is functioning properly. Failure to use a properly functioning surge suppressor could result in damage to the control system of the treadmill. If the control system is damaged, the walking belt may change speed or stop unexpectedly, which may result in a fall and serious injury.

This product must be grounded. If it should malfunction or break down, grounding provides a path of least resistance for electric current to reduce the risk

of electric shock. This product is equipped with a cord having an equipment-grounding conductor and a grounding plug. **Plug the power cord into a surge suppressor, and plug the surge suppressor into an appropriate outlet that is properly installed and grounded in accordance with all local codes and ordinances. Important: The treadmill is not compatible with GFCI-equipped outlets.**

This product is for use on a nominal 120-volt circuit, and has a grounding plug that looks like the plug illustrated in drawing 1 below. A temporary adapter that looks like the adapter illustrated in drawing 2 may be used to connect the surge suppressor to a 2-pole receptacle as shown in drawing 2 if a properly grounded outlet is not available.

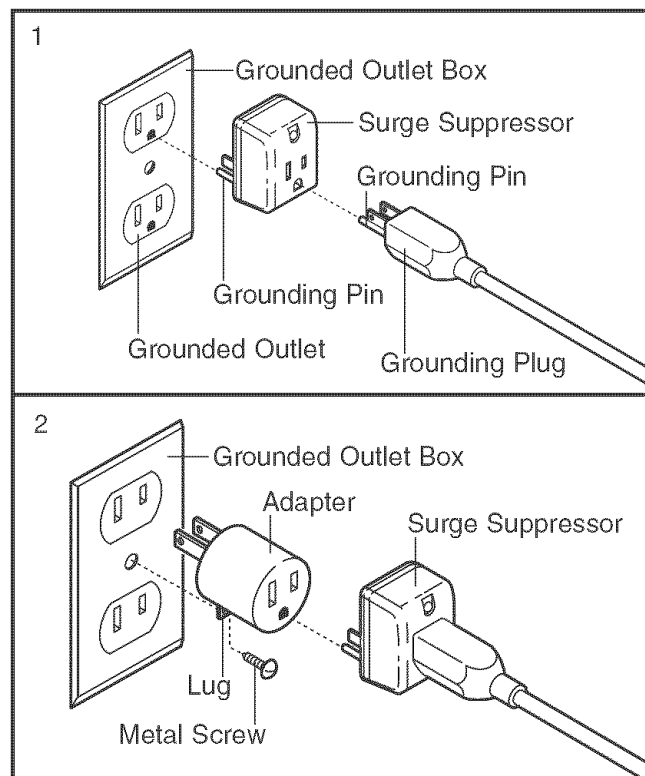

The temporary adapter should be used only until a properly grounded outlet (drawing 1) can be installed by a qualified electrician.

The green-colored rigid ear, lug, or the like extending from the adapter must be connected to a permanent ground such as a properly grounded outlet box cover. Whenever the adapter is used it must be held in place by a metal screw. **Some 2-pole receptacle outlet box covers are not grounded. Contact a qualified electrician to determine if the outlet box cover is grounded before using an adapter.**

DIAGRAM OF THE CONSOLE

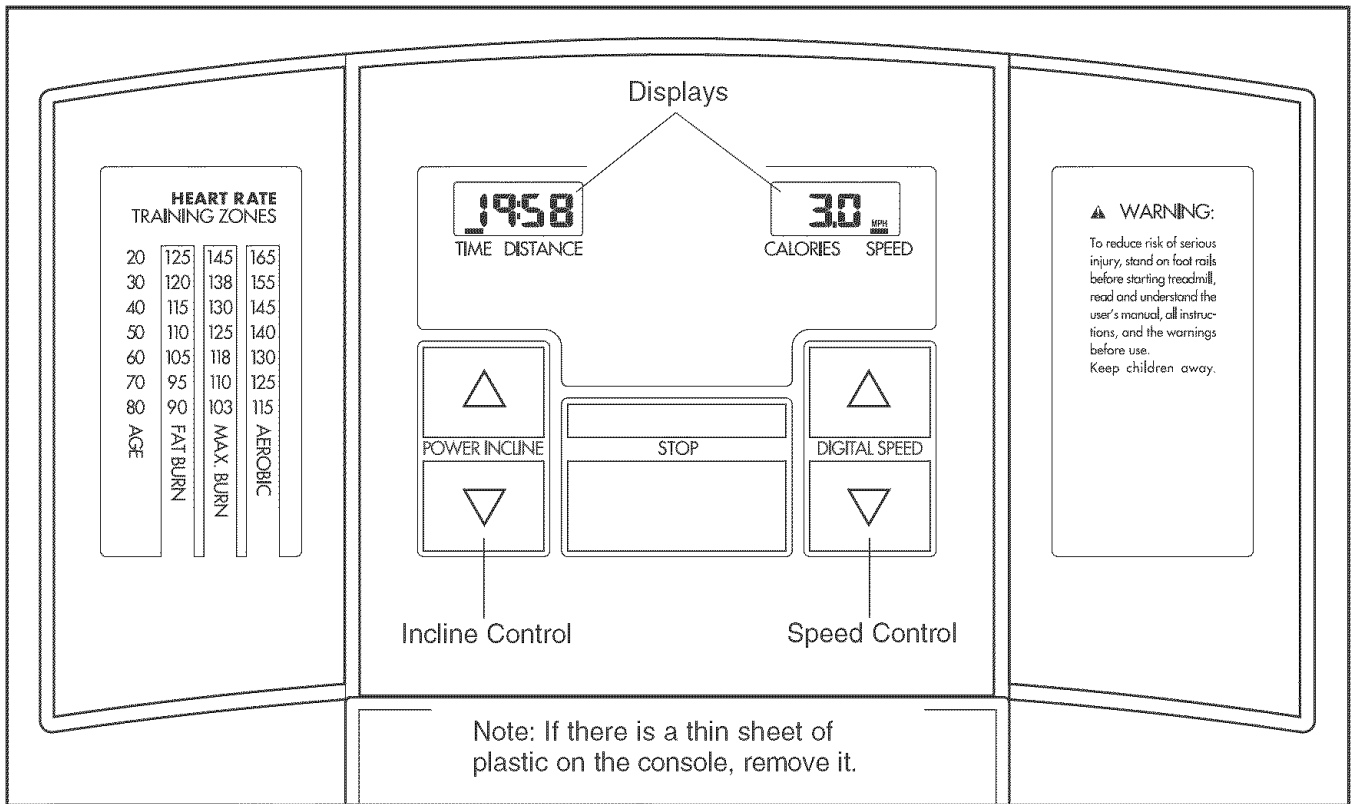

▲ CAUTION: Before operating the console, read the following precautions.

- Do not stand on the walking belt when turning on the power.
- Always wear the clip (see the drawing at the right) while operating the treadmill.
- Adjust the speed in small increments to avoid sudden jumps in speed.
- To reduce the possibility of electric shock, keep the console dry. Avoid spilling liquids on the console and place only a sealed water bottle in the water bottle holder.

STEP-BY-STEP CONSOLE OPERATION

Before operating the console, make sure that the power cord is properly plugged in (see page 8).

Next, locate the circuit breaker near the power cord. Make sure that the circuit breaker is in the reset position.

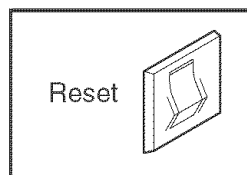

Stand on the foot rails of the treadmill. Find the clip attached to the key, and slide the clip onto the waistband of your clothes.

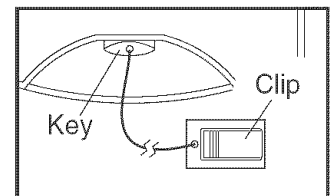

Next, insert the key fully into the console. After a moment, the displays will light. **Test the clip by carefully taking a few steps backward until the key is pulled from the console. If the key is not pulled from the console, adjust the position of the clip.**

Follow the steps below to operate the console.

1 Insert the key fully into the console.

A few seconds after the key is inserted, the displays will light.

2 Press the Speed Δ button to start the walking belt.

A moment after the button is pressed, the walking belt will begin to move. Hold the handrails and begin walking.

As you exercise, change the speed of the walking belt as desired by pressing the Speed buttons. Each time a button is pressed, the speed setting will change by 0.1 mph; if a button is held down, the speed setting will change in increments of 0.5 mph. **Note: The console can display speed and distance in either miles or kilometers (see CALORIES/SPEED DISPLAY at the right). For simplicity, all instructions in this section refer to miles.**

To stop the walking belt, press the Stop button. The Time/Distance display will begin to flash.

Note: During the first few minutes that the treadmill is used, inspect the alignment of the walking belt, and align it if necessary (see page 13).

3 Change the incline of the treadmill as desired.

To change the incline of the treadmill, press either of the Incline buttons until the desired incline level is reached.

4 Follow your progress with the displays.

Time/Distance

display—This display shows the elapsed time and the distance that you have walked or run. The display will change from one number to the other every few seconds, as shown by the mode indicators. When the Stop button is pressed, the display will flash.

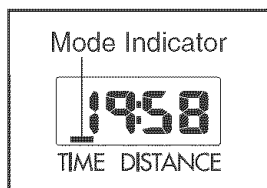

Calories/Speed

display—This display shows the approximate number of calories you have burned and the speed of the walking belt. The display will change from one number to the other every few seconds, as shown by the mode indicators.



Note: The console can display speed and distance in either miles or kilometers. To change the unit of measurement, hold down the Stop button, insert the key into the console, and continue to hold the Stop button for a moment. An “E” for English miles or an “M” for metric kilometers will appear in the Calories/Speed display. Press the Speed Δ button to change the unit of measurement. When the desired unit of measurement is selected, remove the key and then reinsert it.

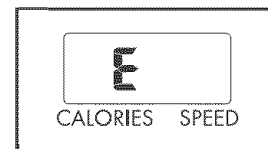

To reset the displays, press the Stop button, remove the key, and then reinsert the key.

5 When you are finished exercising, remove the key.

Step onto the foot rails, press the Stop button, and remove the key from the console. Keep the key in a secure place.

HOW TO FOLD AND MOVE THE TREADMILL

HOW TO FOLD THE TREADMILL FOR STORAGE

Before folding the treadmill, unplug the power cord.

CAUTION: You must be able to safely lift 45 pounds (20 kg) to raise, lower or move the treadmill.

1. Hold the treadmill with your hands in the locations shown at the right. **To decrease the possibility of injury, bend your legs and keep your back straight. As you raise the treadmill, make sure to lift with your legs rather than your back.** Raise the treadmill about halfway to the vertical position.

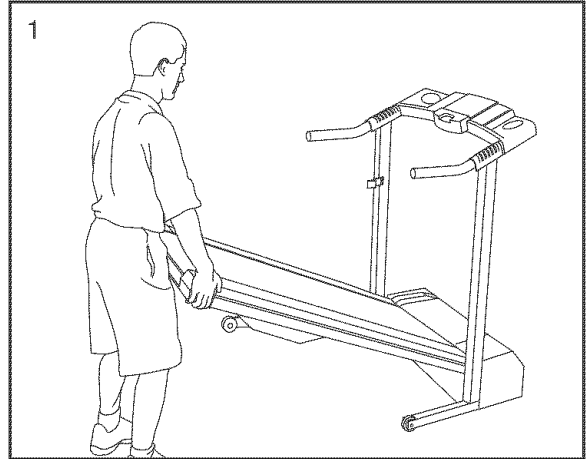

2. Move your right hand to the position shown and hold the treadmill firmly. Raise the treadmill until the storage latch closes over the catch. **Make sure that the storage latch is fully engaged over the catch.**

To protect the floor or carpet from damage, place a mat under the treadmill. Keep the treadmill out of direct sunlight. Do not leave the treadmill in the storage position in temperatures above 85° Fahrenheit.

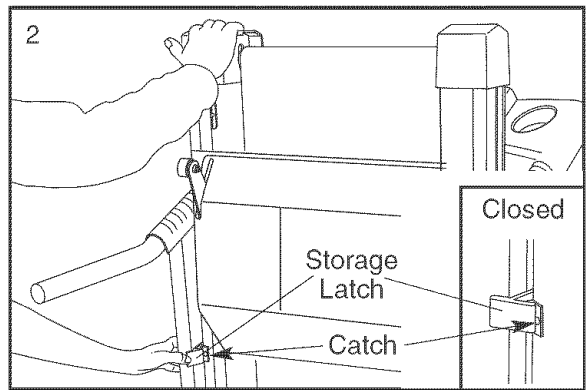

HOW TO MOVE THE TREADMILL

Before moving the treadmill, convert the treadmill to the storage position as described above. **Make sure that the storage latch is fully engaged over the catch.**

1. Hold the upper ends of the handrails. Place one foot on one of the front wheels as shown.
2. Tilt the treadmill back until it rolls freely on the front wheels. Carefully move the treadmill to the desired location. **To reduce the risk of injury, use extreme caution while moving the treadmill. Do not attempt to move the treadmill over an uneven surface.**
3. Place one foot on a front wheel, and carefully lower the treadmill until it is resting in the storage position.

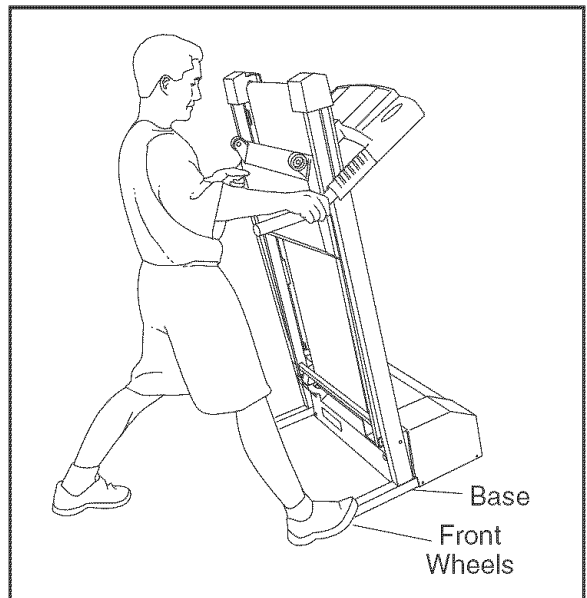

HOW TO LOWER THE TREADMILL FOR USE

1. See drawing 2 above. Hold the upper end of the treadmill with your right hand as shown. Press the storage latch and hold it. Pivot the treadmill until the frame and foot rail are past the storage latch.
2. See drawing 1. Hold the treadmill firmly with both hands, and lower the treadmill to the floor. **Do not drop the treadmill frame to the floor. CAUTION: To decrease the possibility of injury, bend your legs and keep your back straight.**

MAINTENANCE AND TROUBLESHOOTING

Most treadmill problems can be solved by following the steps below. Find the symptom that applies, and follow the steps listed. If further assistance is needed, please call our Customer Service Department toll-free at 1-866-699-3756, Monday through Friday, 6 a.m. until 6 p.m. Mountain Time (excluding holidays).

PROBLEM: The power does not turn on

SOLUTION: a. Make sure that the power cord is plugged into a surge suppressor, and that the surge suppressor is plugged into a properly grounded outlet (see page 8). Use only a single-outlet surge suppressor that meets all of the specifications described on page 8. Important: The treadmill is not compatible with GFCI-equipped outlets.

b. After the power cord has been plugged in, make sure that the key is fully inserted into the console.

c. Check the circuit breaker located on the treadmill frame near the power cord. If the switch protrudes as shown, the circuit breaker has tripped. To reset the circuit breaker, wait for five minutes and then press the switch back in.

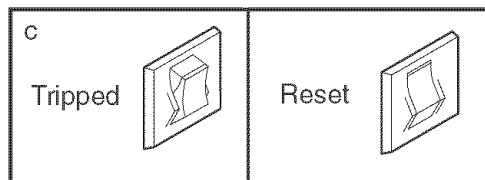

PROBLEM: The power turns off during use

SOLUTION: a. Check the circuit breaker located on the treadmill frame near the power cord (see 1. c. above). If the circuit breaker has tripped, wait for five minutes and then press the switch back in.

b. Make sure that the power cord is plugged in. If the power cord is plugged in, unplug it, wait for five minutes, and then plug it back in.

c. Remove the key from the console. Reinsert the key fully into the console.

d. If the treadmill still will not run, please call our Customer Service Department, toll-free.

PROBLEM: The displays of the console do not function properly

SOLUTION: a. Remove the key from the console and **UNPLUG THE POWER CORD**. Remove the screws from the hood. Note each hole the screws are removed from. Carefully remove the hood. Locate the Reed Switch (13) and the Magnet (63) on the left side of the Pulley (75). Turn the Pulley until the Magnet is aligned with the Reed Switch. **Make sure that the gap between the Magnet and the Reed Switch is about 1/8".** If necessary, loosen the Screw (89), move the Reed Switch slightly, and then retighten the Screw. Reattach the hood, making sure that the screws are tightened into the original holes. Run the treadmill for a few minutes to check for a correct speed reading.

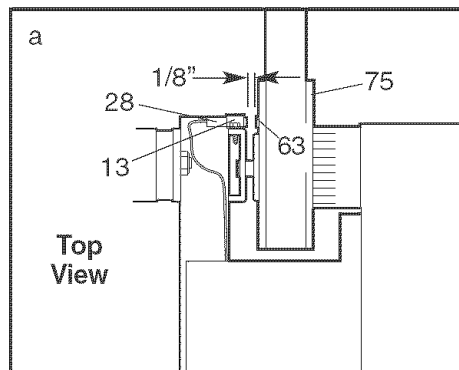

PROBLEM: The walking belt slows when walked on

SOLUTION: a. Use only a single-outlet surge suppressor that meets all of the specifications described on page 8.

b. If the walking belt is overtightened, treadmill performance may decrease and the walking belt may become damaged. Remove the key and **UNPLUG THE POWER CORD**. Using the allen wrench, turn both rear roller adjustment bolts counterclockwise, 1/4 of a turn. When the walking belt is properly tightened, you should be able to lift each side of the walking belt 2 to 3 inches off the walking platform. Be careful to keep the walking belt centered. Plug in the power cord, insert the key, and run the treadmill for a few minutes. Repeat until the walking belt is properly tightened.

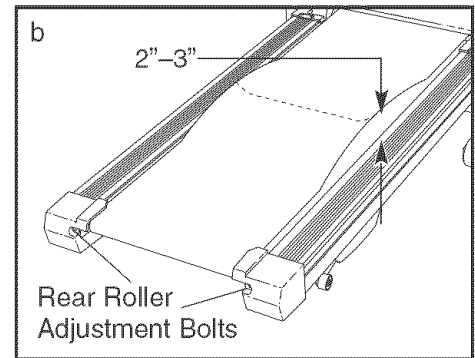

c. If the walking belt still slows when walked on, please call our Customer Service Department, toll-free.

PROBLEM: The walking belt is off-center or slips when walked on

SOLUTION: a. If the walking belt is off-center, first remove the key and **UNPLUG THE POWER CORD**. If the walking belt has shifted to the left, use the allen wrench to turn the left rear roller bolt clockwise 1/2 of a turn; if the walking belt has shifted to the right, turn the bolt counterclockwise 1/2 of a turn. Be careful not to overtighten the walking belt. Plug in the power cord, insert the key, and run the treadmill for a few minutes. Repeat until the walking belt is centered.

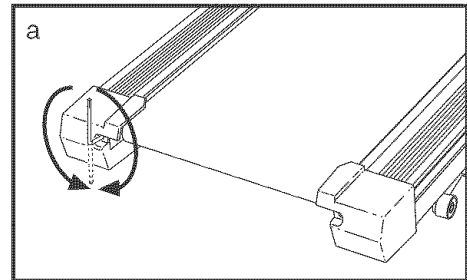

b. If the walking belt slips when walked on, first remove the key and **UNPLUG THE POWER CORD**. Using the allen wrench, turn both rear roller bolts clockwise, 1/4 of a turn. When the walking belt is correctly tightened, you should be able to lift each side of the walking belt 2 to 3 inches off the walking platform. Be careful to keep the walking belt centered. Plug in the power cord, insert the key, and carefully walk on the treadmill for a few minutes. Repeat until the walking belt is properly tightened.

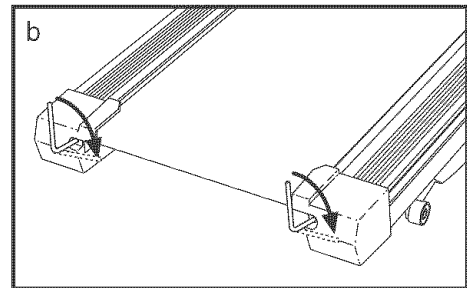

CONDITIONING GUIDELINES

▲ WARNING: Before beginning this or any exercise program, consult your physician. This is especially important for individuals over the age of 35 or individuals with pre-existing health problems.

The following guidelines will help you to plan your exercise program. For more detailed exercise information, obtain a reputable book or consult your physician.

EXERCISE INTENSITY

Whether your goal is to burn fat or to strengthen your cardiovascular system, the key to achieving the desired results is to exercise with the proper intensity. The proper intensity level can be found by using your heart rate as a guide. The chart below shows recommended heart rates for fat burning and aerobic exercise.

HEART RATE TRAINING ZONES							
AEROBIC	165	155	145	140	130	125	115
MAX FAT BURN	145	138	130	125	113	110	103
FAT BURN	125	120	115	110	105	95	90
Age	20	30	40	50	60	70	80

To find the proper heart rate for you, first find your age at the bottom of the chart (ages are rounded off to the nearest ten years). Next, find the three numbers at the top of your age. The three numbers are your "training zone." The lower two numbers are recommended heart rates for fat burning; the highest number is the recommended heart rate for aerobic exercise.

Fat Burning

To burn fat effectively, you must exercise at a relatively low intensity level for a sustained period of time. During the first few minutes of exercise, your body uses easily accessible *carbohydrate calories* for energy. Only after the first few minutes does your body begin to use stored *fat calories* for energy. If your goal is to burn fat, adjust the speed and incline of the treadmill until your heart rate is near one of the lower two numbers in your training zone. It may also be helpful to set the speed control on the console to FAT BURN to help you maintain the proper intensity level. (See page 9.)

Aerobic Exercise

If your goal is to strengthen your cardiovascular system, your exercise must be "aerobic." Aerobic exercise is activity that requires large amounts of oxygen for prolonged periods of time. This increases the demand on the heart to pump blood to the muscles, and on the lungs to oxygenate the blood. For aerobic exercise, adjust the speed and incline of the treadmill until your heart rate is near the highest number in your training zone. It may also be helpful to set the speed control on the console to AEROBIC to help you maintain the proper intensity level. (See page 9.)

High Performance Athletic Conditioning

If your goal is high performance athletic conditioning, set the speed control on the console to PERFORMANCE to help you maintain the proper intensity level. (See page 9.) Note: During the first few weeks of your exercise program, keep your heart rate near the low end of your training zone.

HOW TO MEASURE YOUR HEART RATE

To measure your heart rate, stop exercising and place two fingers on your wrist as shown. Take a six-second heart-beat count, and multiply the result by ten to find your heart rate. (A six-second count is used because your heart rate drops quickly when you stop exercising.) If your heart rate is too high or too low, adjust the speed or incline of the treadmill accordingly.

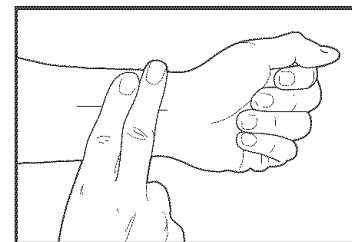

WORKOUT GUIDELINES

A well-rounded workout includes the following three important parts:

A Warm-up

Start each workout with 5 to 10 minutes of stretching and light exercise. A proper warm-up increases your body temperature, heart rate, and circulation in preparation for exercise.

Training Zone Exercise

After warming up, increase the intensity of your exercise until your pulse is in your training zone for 20 to 60 minutes. (During the first few weeks of your exercise program, do not keep your pulse in your training zone for longer than 20 minutes.) Breathe regularly and deeply as you exercise—never hold your breath.

A Cool-down

Finish each workout with 5 to 10 minutes of stretching

to cool down. This will increase the flexibility of your muscles and will help to prevent post-exercise problems.

EXERCISE FREQUENCY

To maintain or improve your condition, complete three workouts each week, with at least one day of rest between workouts. After a few months, you may complete up to five workouts each week if desired.

The key to success is to make exercise a regular and enjoyable part of your everyday life.

PART IDENTIFICATION CHART

Remove this chart and use it to identify small parts during assembly. Save this chart and the EXPLODED DRAWING/PART LIST for future reference.

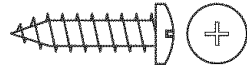

3/4" Screw (5)-13

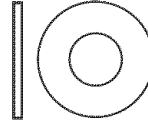

Handrail Washer
(40)-4

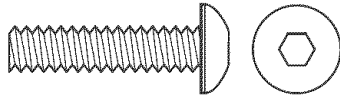

1" Bolt (16)-4

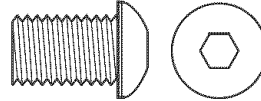

Extension Leg Screw (14)-2

PART LIST—Model No. WLTL211040

R0904A

Key No.	Qty.	Description	Key No.	Qty.	Description
1	4	Front Endcap Screw	56	1	5/32" Allen Wrench
2	6	Star Washer	57	1	Choke
3	2	Plastic Tie	58	2	Belt Guide
4	2	Handrail	59	1	Console Warning Decal
5	15	3/4" Screw	60	2	Isolator
6	1	Key/Clip	61	1	Latch Catch
7	1	Hole Plug	62	1	Frame Spacer (Left)
8	1	Incline Leg	63	1	Magnet
9	2	Handrail Endcap	64	2	Incline Leg Pivot Bolt
10	1	Wire Cover	65	1	Belly Pan
11	1	Console	66	1	Latch
12	1	Console Cover	67	1	Walking Belt
13	1	Reed Switch	68	3	Wire Tie
14	2	Extension Leg Screw	69	4	Wire Tie Clamp
15	2	Extension Leg	70	1	Incline Wire
16	4	1" Bolt	71	1	Walking Platform
17	4	Cage Nut	72	1	Frame Spacer (Right)
18	1	Motor Belt	73	1	Left Foot Rail
19	2	Motor Tension Bolt	74	1	Sensor Clip
20	1	Motor Tension Washer	75	1	Front Roller/Pulley
21	1	Tension Star Washer	76	10	Electronic Screw
22	1	Motor Pivot Nut	77	1	Ground Wire
23	1	Motor/Pulley/Flywheel/Fan	78	2	Rear Roller Adj. Bolt
24	1	Pulley/Flywheel/Fan	79	1	Left Rear Endcap
25	1	Motor	80	1	Upright Grommet
26	1	Motor Pivot Bolt	81	1	Allen Wrench
27	5	8" Cable Tie	82	1	Latch Decal
28	17	Screw	83	1	Rear Roller
29	1	Hood	84	1	Frame
30	1	Hood Shield	85	1	Console Lens
31	2	Hood Screw (Front)	86	1	Right Front Endcap
32	7	Isolator Screw	87	1	Console Base
33	4	Base Pad	88	1	Motor Shield
34	1	Motor Belly Pan	89	1	Latch Catch Screw
35	1	Controller	90	1	Right Rear Endcap
36	2	Frame Pivot Bolt	91	1	Left Front Endcap
37	2	Frame Pivot Washer	92	4	Incline Nut
38	1	Upright/Base	93	1	Incline Stop Bracket
39	4	Belt Guide Screw	94	1	Incline Motor Bolt (Lower)
40	8	Roller Washer/Handrail Washer	95	2	Incline Motor Nut
41	2	Wheel Bolt	96	1	Incline Motor
42	2	Wheel	97	1	Circuit Board Bracket
43	6	Frame Nut/Wheel Nut	98	4	Plastic Stand-off
44*	2	Extension Leg Assembly	99	1	Circuit Board
45	1	Circuit Breaker	100	4	Lift Frame Nut
46	1	Grommet	#	1	8" White Wire, Pigtail
47	1	Power Cord	#	1	4" Red Wire, M/F
48	1	Motor Tension Nut	#	1	4" Black Wire, M/F
49*	1	Console Assembly	#	1	4" Black Wire, 2F
50	1	Right Foot Rail	#	1	6" Blue Wire, 2F
51	4	Platform Screw	#	1	User's Manual
52	1	Front Roller Adj. Bolt			
53	1	Wire Harness			
54	2	Incline Wheel Bolt			
55	2	Incline Wheel			

*Includes all parts shown in the box
 "#" indicates a non-illustrated part.

EXPLODED DRAWING—Model No. WLTL211040

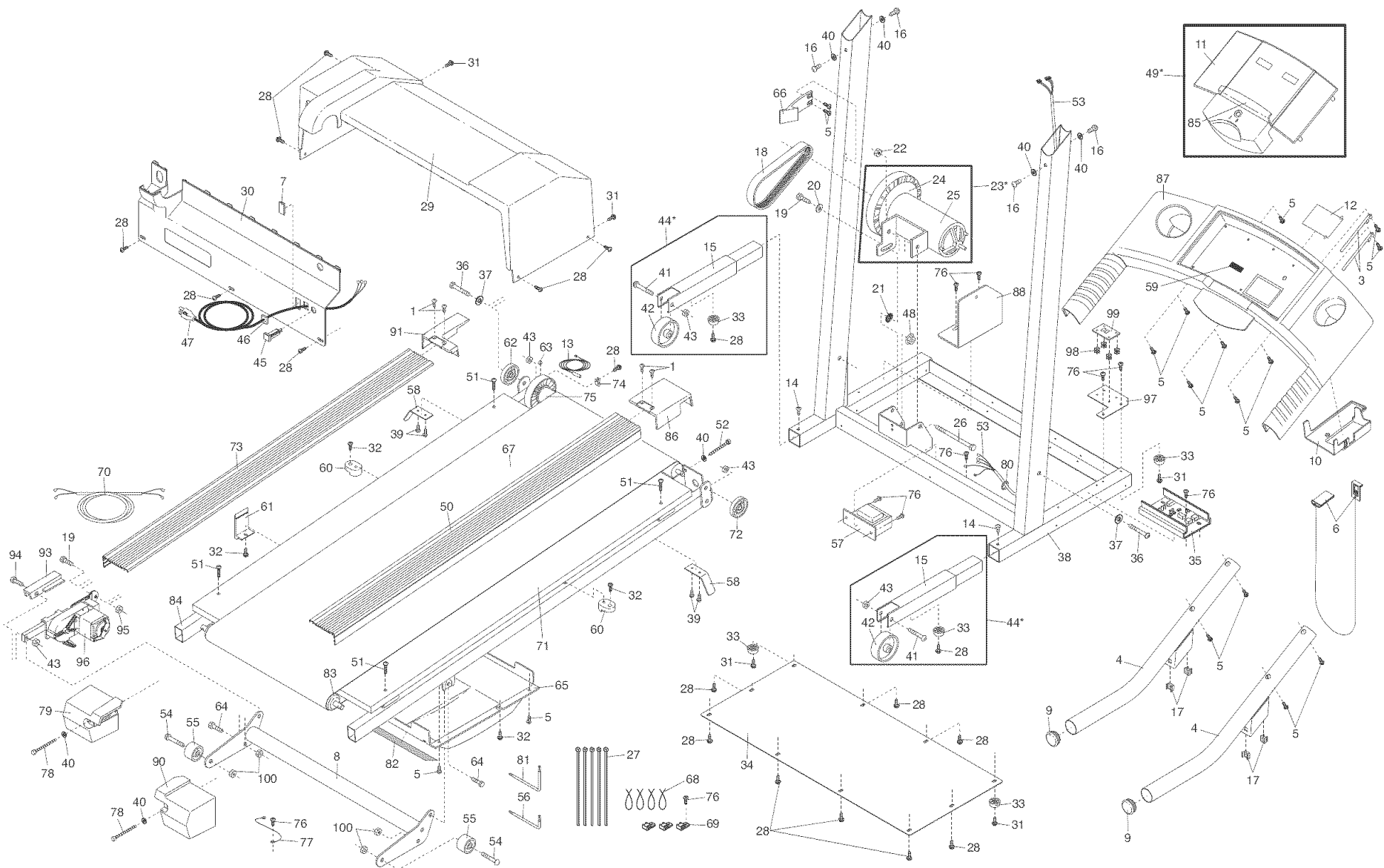

ORDERING REPLACEMENT PARTS

To order replacement parts, call our Customer Service Department toll-free at 1-866-699-3756, Monday through Friday, 6 a.m. until 6 p.m. Mountain Time (excluding holidays). When ordering parts, please be prepared to give the following information:

- The MODEL NUMBER of the product (WLTL211040)
- The NAME of the product (WESLO® CADENCE 255 DR treadmill)
- The SERIAL NUMBER of the product (see the front cover of this manual)
- The KEY NUMBER and DESCRIPTION of the desired part(s) (see the PART LIST and the EXPLODED DRAWING in the center of this manual)

LIMITED WARRANTY

ICON Health & Fitness, Inc. (ICON), warrants this product to be free from defects in workmanship and material, under normal use and service conditions, for a period of ninety (90) days from the date of purchase. This warranty extends only to the original purchaser. ICON's obligation under this warranty is limited to replacing or repairing, at ICON's option, the product through one of its authorized service centers. All repairs for which warranty claims are made must be pre-authorized by ICON. This warranty does not extend to any product or damage to a product caused by or attributable to freight damage, abuse, misuse, improper or abnormal usage or repairs not provided by an ICON authorized service center; products used for commercial or rental purposes; or products used as store display models. No other warranty beyond that specifically set forth above is authorized by ICON.

ICON is not responsible or liable for indirect, special or consequential damages arising out of or in connection with the use or performance of the product or damages with respect to any economic loss, loss of property, loss of revenues or profits, loss of enjoyment or use, costs of removal or installation or other consequential damages of whatsoever nature. Some states do not allow the exclusion or limitation of incidental or consequential damages. Accordingly, the above limitation may not apply to you.

The warranty extended hereunder is in lieu of any and all other warranties and any implied warranties of merchantability or fitness for a particular purpose is limited in its scope and duration to the terms set forth herein. Some states do not allow limitations on how long an implied warranty lasts. Accordingly, the above limitation may not apply to you.

This warranty gives you specific legal rights. You may also have other rights which vary from state to state.

ICON HEALTH & FITNESS, INC., 1500 S. 1000 W., LOGAN, UT 84321-9813