

510cs

Model No. WLEX19820

Serial No. \_\_\_\_\_

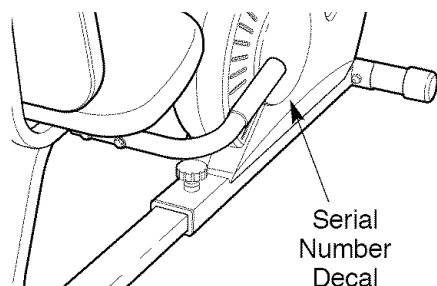

## USER'S MANUAL

### QUESTIONS?

As a manufacturer, we are committed to providing complete customer satisfaction. If you have questions, or if there are missing parts, we will guarantee complete satisfaction through direct assistance from our factory.

TO AVOID DELAYS, PLEASE CALL DIRECT TO OUR TOLL-FREE CUSTOMER HOT LINE. The technicians on our customer hot line will provide immediate assistance, free of charge to you.

CUSTOMER HOT LINE:

**1-800-999-3756**

Mon.-Fri., 6 a.m.-6 p.m. MST

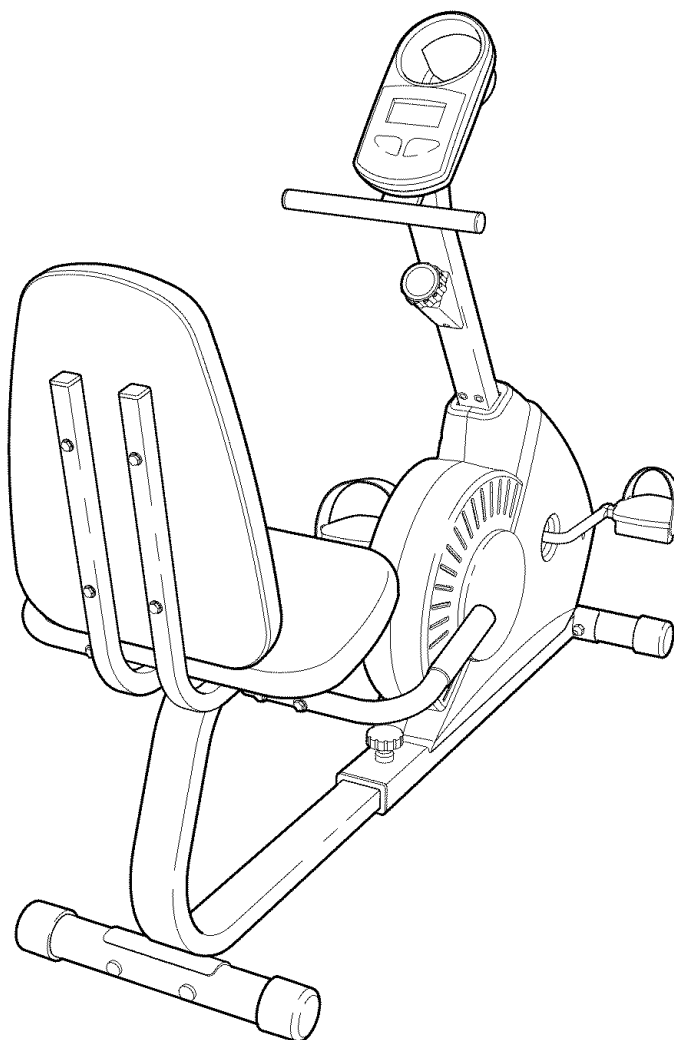

### **CAUTION**

Read all precautions and instructions in this manual before using this equipment. Keep this manual for future reference.



Visit our website at

[www.weslo.com](http://www.weslo.com)

new products, prizes,  
fitness tips, and much more!

# TABLE OF CONTENTS

IMPORTANT PRECAUTIONS	2
BEFORE YOU BEGIN	3
ASSEMBLY	4
HOW TO OPERATE THE EXERCISE CYCLE	8
MAINTENANCE AND TROUBLESHOOTING	10
CONDITIONING GUIDELINES	12
PART LIST	14
EXPLODED DRAWING	15
ORDERING REPLACEMENT PARTS	Back Cover
LIMITED WARRANTY	Back Cover

## IMPORTANT PRECAUTIONS

**⚠ WARNING:** To reduce the risk of serious injury, read the following important precautions before using the exercise cycle.

1. Read all instructions in this manual before using the exercise cycle.
2. Use the exercise cycle only as described in this manual.
3. It is the responsibility of the owner to ensure that all users of the exercise cycle are adequately informed of all precautions.
4. Use the exercise cycle indoors on a level surface. Keep the exercise cycle away from moisture and dust. Place a mat under the exercise cycle to protect the floor.
5. Inspect and properly tighten all parts regularly. Replace any worn parts immediately.
6. Keep children under the age of 12 and pets away from the exercise cycle at all times.
7. Wear appropriate clothing when exercising; do not wear loose clothing that could become caught on the exercise cycle. Always wear athletic shoes for foot protection.
8. The exercise cycle should not be used by persons weighing more than 250 pounds.
9. Always keep your back straight while using the exercise cycle; do not arch your back.
10. If you feel pain or dizziness while exercising, stop immediately and cool down.
11. The exercise cycle does not have a free wheel; the pedals will continue to move until the flywheel stops.
12. The exercise cycle is intended for home use only. Do not use the exercise cycle in a commercial, rental, or institutional setting.

**⚠ WARNING:** Before beginning this or any exercise program, consult your physician. This is especially important for persons over the age of 35 or persons with pre-existing health problems. Read all instructions before using. ICON assumes no responsibility for personal injury or property damage sustained by or through the use of this product.

# BEFORE YOU BEGIN

Congratulations for selecting the new WESLO® PURSUIT 510 CS exercise cycle. Cycling is one of the most effective exercises for increasing cardiovascular fitness, building endurance, and toning the body. The PURSUIT 510 CS exercise cycle offers a selection of features designed to let you enjoy this healthful exercise in the convenience and privacy of your home.

**For your benefit, read this manual carefully before you use the exercise cycle.** If you have questions after reading this manual, please call our Customer

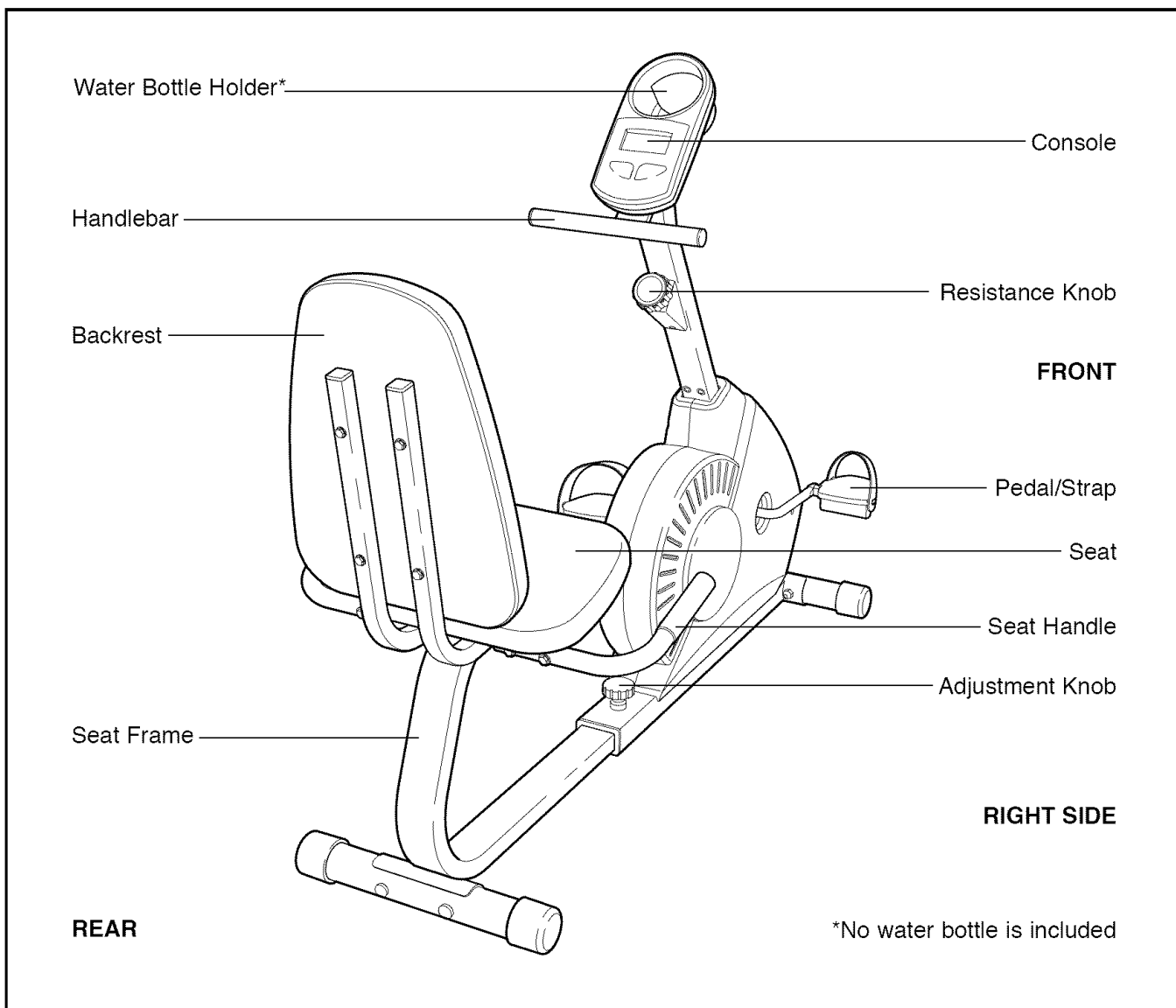

Service Department toll-free at 1-800-999-3756, Monday through Friday, 6 a.m. until 6 p.m. Mountain Time (excluding holidays). To help us assist you, please note the product model number and serial number before calling. The model number is WLEX19820. The serial number can be found on a decal attached to the exercise cycle (see the front cover of this manual for the location of the decal).

Before reading further, please familiarize yourself with the parts that are labeled in the drawing below.



# ASSEMBLY

**Assembly requires two persons.** Place all parts of the exercise cycle in a cleared area and remove the packing materials. Do not dispose of the packing materials until assembly is completed.

**In addition to the included tools, assembly requires a Phillips screwdriver** , **two adjustable wrenches** , and **pliers** .

Use the part drawings below to identify the small parts used in assembly. The number in parenthesis below each drawing refers to the key number of the part, from the PART LIST on page 14. The second number refers to the quantity needed for assembly. **Note: Some small parts may have been pre-attached for shipping. If a part is not in the parts bag, check to see if it has been pre-attached.**

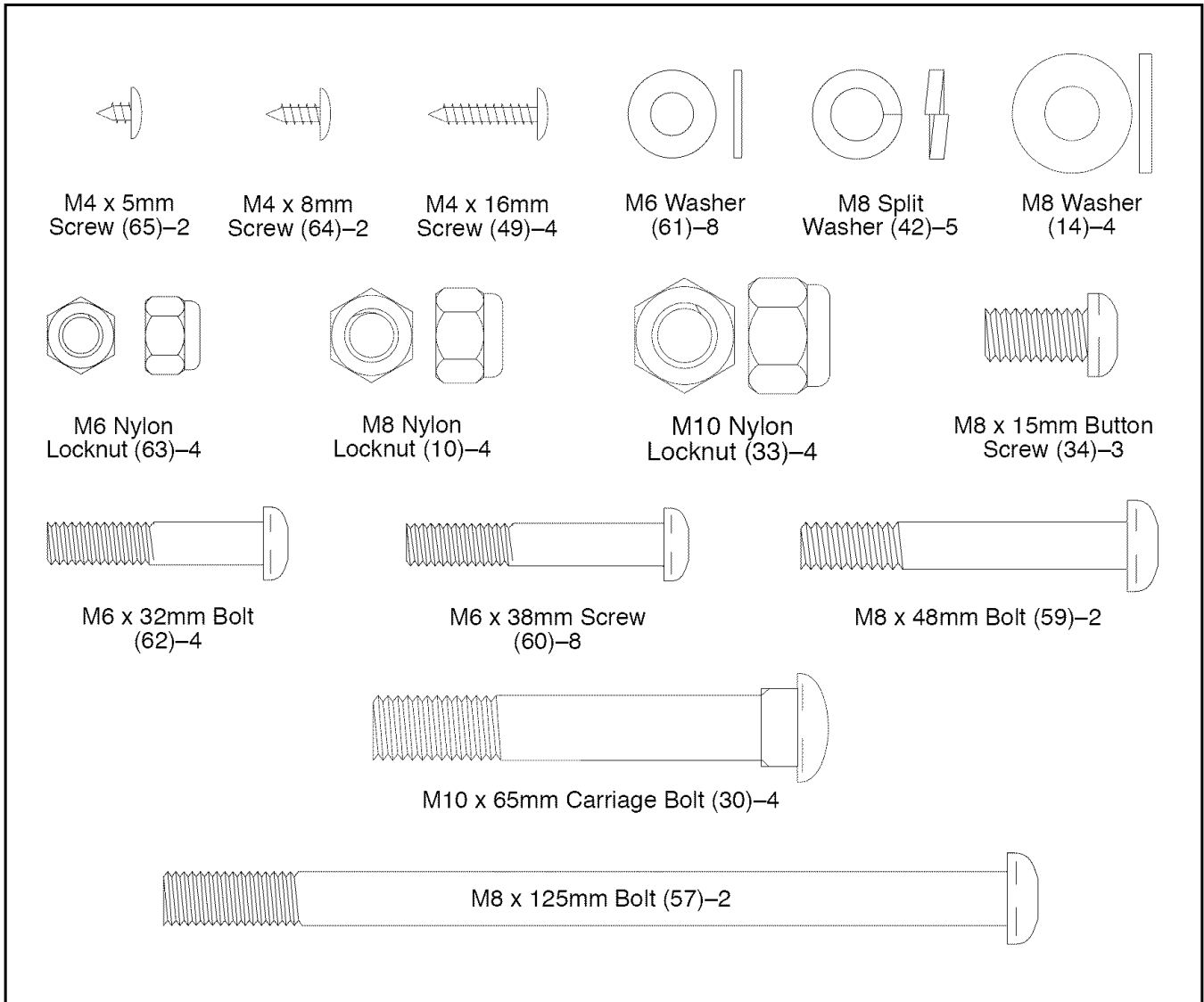

1. While another person lifts the front of the Frame (1) slightly, attach a Stabilizer (2) with two M10 x 65mm Carriage Bolts (30) and two M10 Nylon Locknuts (33).

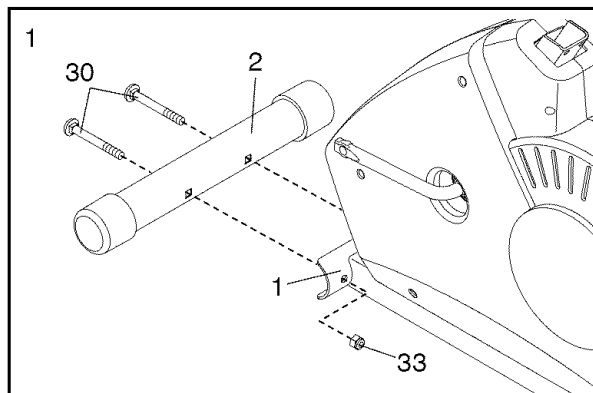

2. Attach a Stabilizer (2) to the Seat Frame (5) with two M10 x 65mm Carriage Bolts (30) and two M10 Nylon Locknuts (33).

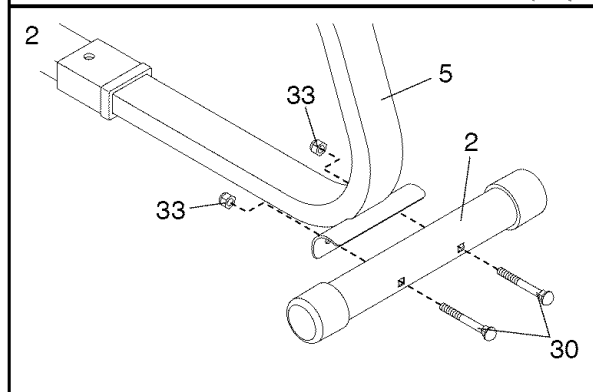

3. Insert the end of the Seat Frame (5) into the Frame (1). Next, firmly press the Seat Frame Bushing (20) into the Frame. Secure the Seat Frame Bushing to the Frame with two M4 x 5mm Screws (65). Tighten the Adjustment Knob (9) into the Frame.

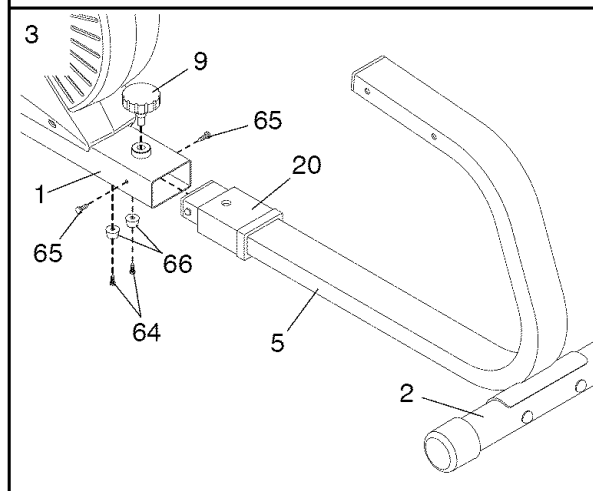

Carefully tip the exercise cycle onto its side. Attach the two Bumpers (66) to the Frame (1) with two M4 x 8mm Screws (64). Then, tip the exercise cycle back onto the Stabilizers (2).

4. Attach the Left and Right Seat Brackets (52, 53) to the Seat Frame (5) with two M8 x 125mm Bolts (57), four M8 Washers (14), and two M8 Nylon Locknuts (10) as shown. **Do not tighten the Nylon Locknuts yet.**

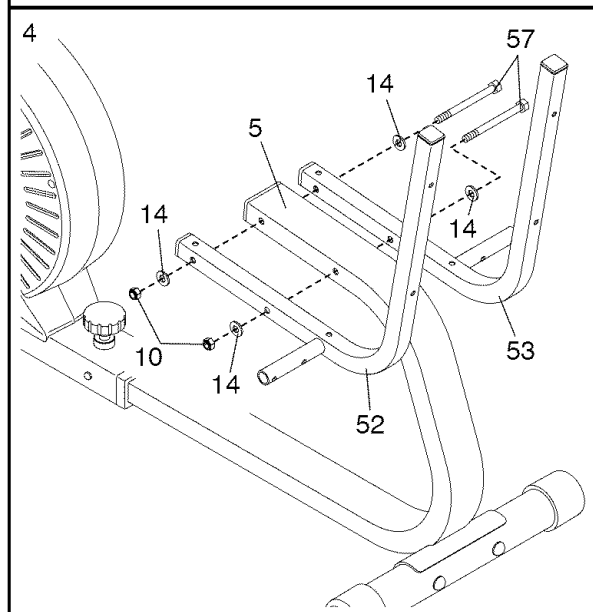

5. Attach a Seat Handle (50) to the round tube on the Left Seat Bracket (52) with two M6 x 32mm Bolts (62) and two M6 Nylon Locknuts (63).

Attach the other Seat Handle (50) to the Right Seat Frame (53) in the same way.

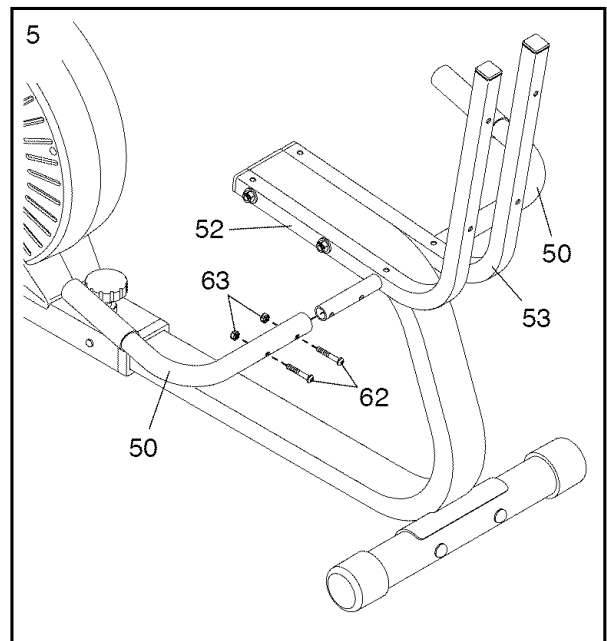

6. Attach the Backrest (54) to the Seat Brackets (52, 53) with four M6 x 38mm Screws (60) and four M6 Washers (61).

See step 4. Tighten the two M8 Nylon Locknuts (10).

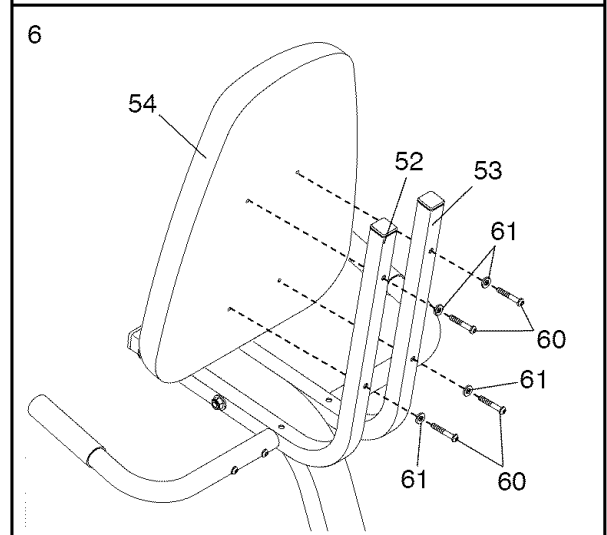

7. Attach the Seat (12) to the Seat Brackets (52, 53) with four M6 x 38mm Screws (60) and four M6 Washers (61).

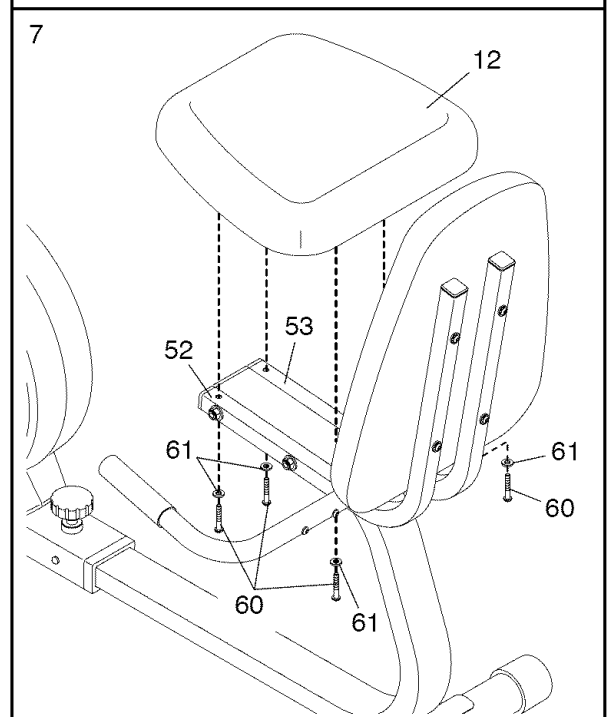

8. The Console (16) requires three AA batteries (not included); alkaline batteries are recommended. Insert three batteries into the Console as shown. **Make sure that the batteries are oriented as shown by the markings inside the Console.**

Hold the Console (16) near the Handlebar (15). Insert the console wire down through the indicated hole in the Handlebar. Note: The console wire is longer than shown.

Attach the Console (16) to the Handlebar (15) with four M4 x 16mm Screws (49). **Be careful to avoid pinching the console wire.**

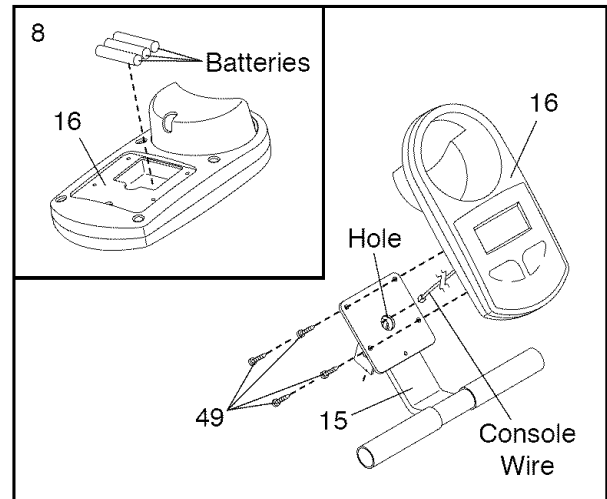

9. While another person holds the Handlebar (15) near the Upright (13), insert the console wire down through the Upright. Attach the Handlebar to the Upright with three M8 x 15mm Button Screws (34) and three M8 Split Washers (42). **Be careful to avoid pinching the console wire.** Note: The console wire is longer than shown.

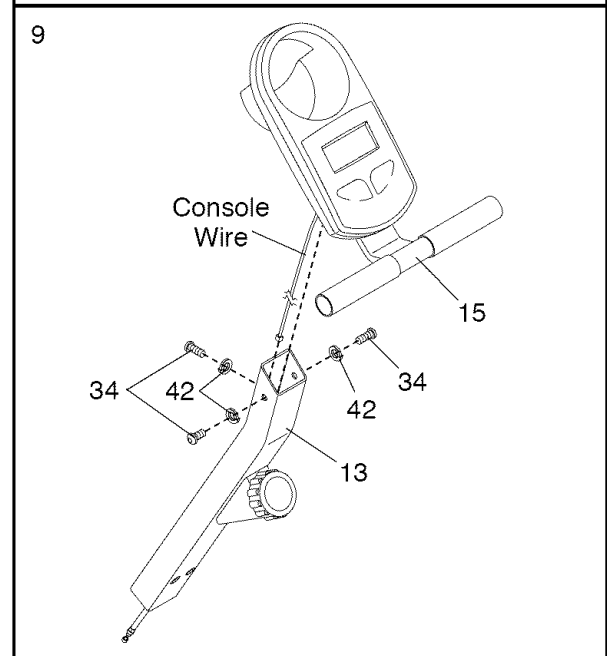

10. While another person holds the Upright (13) in the position shown, connect the console wire to the Reed Switch Wire (43). Next, connect the console cable to the Lower Cable (45) in the following way:

- See drawing A. Pull up on the metal bracket on the Lower Cable (45), and insert the tip of the console cable (CC) into the wire clip inside the metal bracket as shown.
- See drawing B. Firmly pull up the console cable (CC) and slide it into the top of the metal bracket as shown.
- See drawing C. Using pliers, squeeze the prongs on the upper end of the metal bracket together.

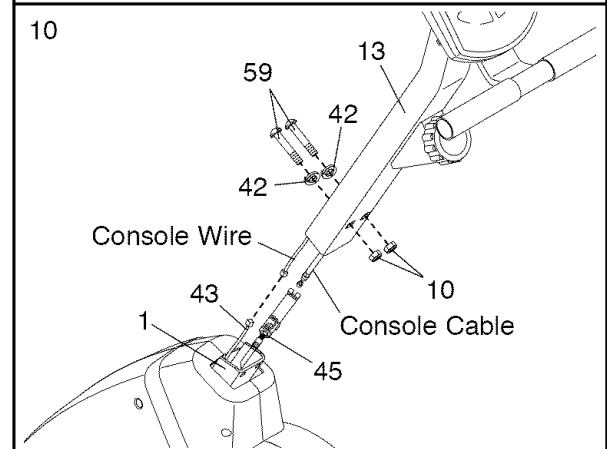

Push the excess wire and cable down into the Frame (1), and insert the Upright (13) into the Frame. **Be careful to avoid pinching the wires and cables.** Attach the Upright to the Frame with two M8 x 48mm Bolts (59), two M8 Split Washers (42), and two M8 Nylon Locknuts (10).

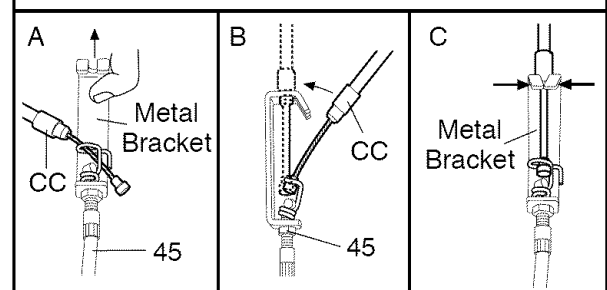

11. Identify the Left Pedal (24), which is marked with an "L." Using an adjustable wrench, **firmly tighten** the Left Pedal counterclockwise into the left arm of the Crank (21). Tighten the Right Pedal (not shown) clockwise into the right arm of the Crank. **Important: Tighten both Pedals as firmly as possible. After using the exercise cycle for one week, retighten the Pedals. For best performance, the Pedals must be kept tightened.**

Adjust the left Pedal Strap (58) to the desired position, and press the end of the Pedal Strap onto the tab on the Left Pedal (24). Adjust the right Pedal Strap (not shown) in the same way.

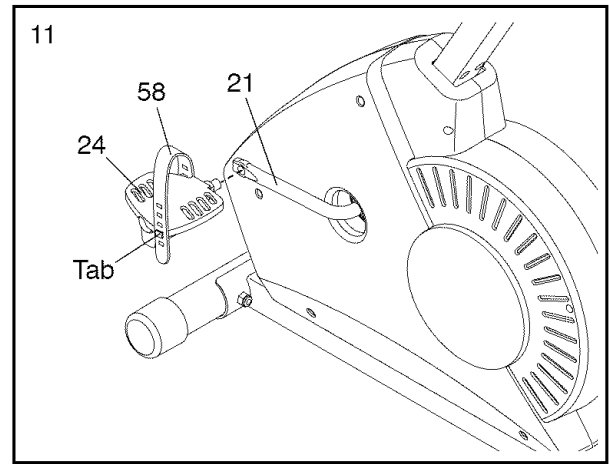

12. **Make sure that all parts are properly tightened before you use the exercise cycle.** After assembly is completed, some extra parts may be left over. Place a mat under the exercise cycle to protect the floor.

## HOW TO OPERATE THE EXERCISE CYCLE

### HOW TO ADJUST THE SEAT FRAME

For effective exercise, the seat should be in the proper position. As you pedal, there should be a slight bend in your knees when the pedals are in the farthest position. To adjust the seat frame, first loosen the adjustment knob on the frame. Slide the seat frame forward or backward to the desired position. Retighten the adjustment knob.

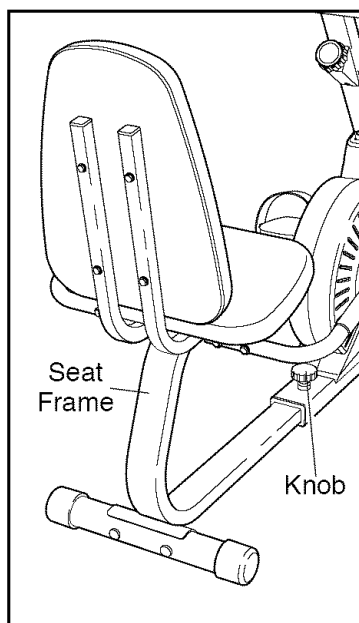

### HOW TO ADJUST THE PEDALING RESISTANCE

To increase the resistance of the pedals, turn the resistance knob clockwise; to decrease the resistance, turn the knob counterclockwise. **Important: Stop turning the knob when turning becomes difficult, or damage may result.**

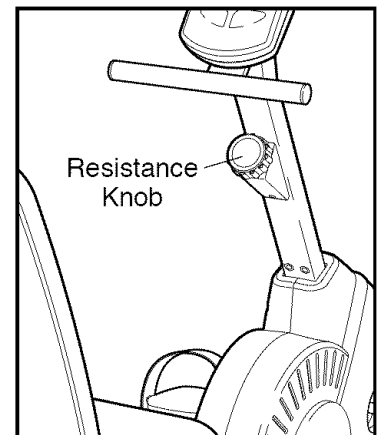



## FEATURES OF THE CONSOLE

The easy-to-use console features five modes that provide instant exercise feedback during your workouts. The modes are described below.

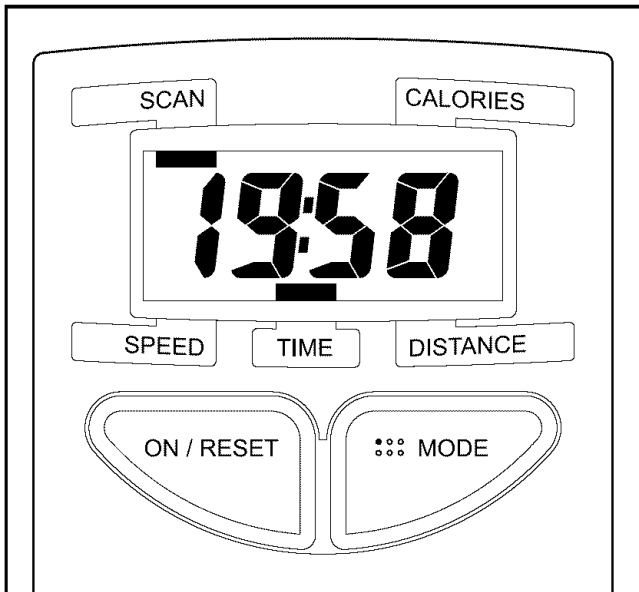

**Speed**—This mode displays your pedaling speed, in miles per hour or kilometers per hour.

**Time**—This mode displays the elapsed time. Note: If you stop pedaling for a few seconds, the time mode will pause.

**Distance**—This mode displays the distance you have pedaled, in miles or kilometers.

**Calorie**—This mode displays the approximate number of calories you have burned.

**Scan**—This mode displays the speed, time, distance, and calorie modes, for a few seconds each, in a repeating cycle.

## HOW TO OPERATE THE CONSOLE

Make sure there are batteries in the console (see BATTERY REPLACEMENT on page 10). If there is a thin sheet of clear plastic on the console, remove it.

Follow the steps below to operate the console.

1. To turn on the power, press the On/Reset button or begin pedaling. The entire display will briefly appear; the console will then be ready for use.

2. Select one of the modes:

**Scan mode**—When the power is turned on, the scan mode will be selected automatically. A mode indicator will appear below the word “SCAN” to show that the scan mode is selected, and a second mode indicator will show which mode is currently displayed. Note: If you have selected a different mode, repeatedly press the Mode button to reselect the scan mode.

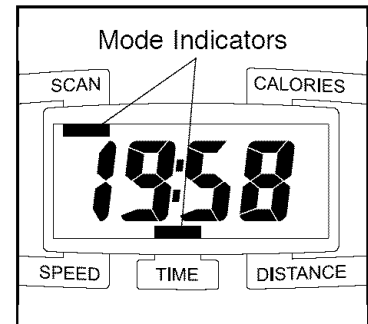

**Speed, time, distance, or calorie mode**—To select one of these modes for continuous display, repeatedly press the Mode button. The mode indicators will show which mode is selected. Make sure there is not a mode indicator below the word “SCAN.”

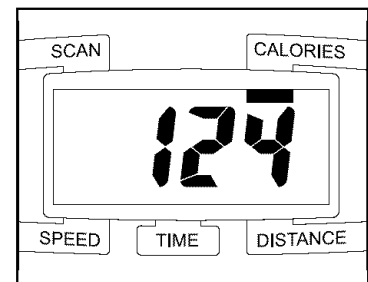

**Note: The console can display speed and distance in either miles or kilometers. To change the unit of measurement, press the On/Reset button for about five seconds.** The letters mph or km/h will appear in the display to show which unit of measurement is selected. When the batteries are replaced, it may be necessary to reselect the desired unit of measurement.

3. To reset the display at any time, press the On/Reset button.
4. To turn off the power, simply wait for a few minutes. **The console has an “auto-off” feature. If the pedals are not moved and the console buttons are not pressed for a few minutes, the power will turn off automatically to save the batteries.**

# MAINTENANCE AND TROUBLESHOOTING

Inspect and properly tighten all parts of the exercise cycle regularly. Replace any worn parts immediately.

To clean the exercise cycle, use a damp cloth and a small amount of mild detergent. **Important: To avoid damage to the console, keep liquids away from the console and keep the console out of direct sunlight.**

## BATTERY REPLACEMENT

If the console display becomes dim, the batteries should be replaced; most console problems are the result of low batteries. To replace the batteries, refer to assembly step 8 on page 7 and remove the console from the handlebar. Next, insert three batteries into the console. Reattach the console to the handlebar, being careful not to pinch the console wire.

## HOW TO ADJUST THE RESISTANCE STRAP

If the resistance knob is turned to the highest setting and there is not enough resistance, the resistance strap may need to be adjusted. To adjust the resistance strap, you must first remove the left side shield.

Using an adjustable wrench, turn the Left Pedal (24) clockwise and remove it. Next, remove the five M4 x 25mm Screws (41) and the M4 x 16mm Screw (49) from the Left Side Shield (17). Carefully remove the Left Side Shield.

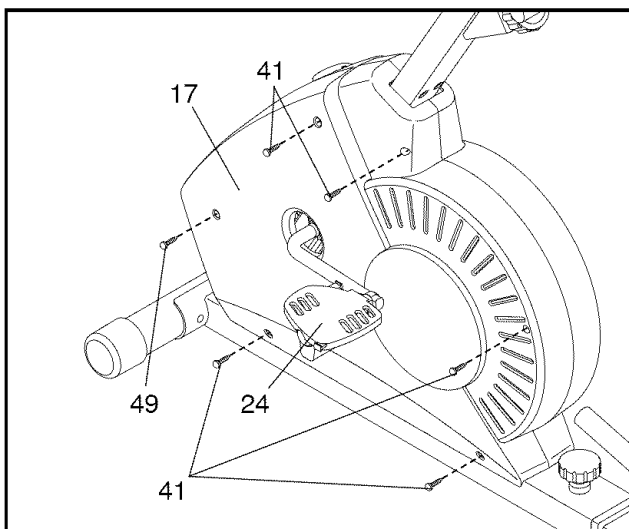

Next, turn the resistance knob to the lowest setting (see HOW TO ADJUST THE PEDALING RESISTANCE on page 8).

Open the Strap Clamp (3) and pull the end of the Resistance Strap (11) downward slightly to increase resistance. Close the Strap Clamp and turn the Flywheel (37) to make sure there is not too much resistance.

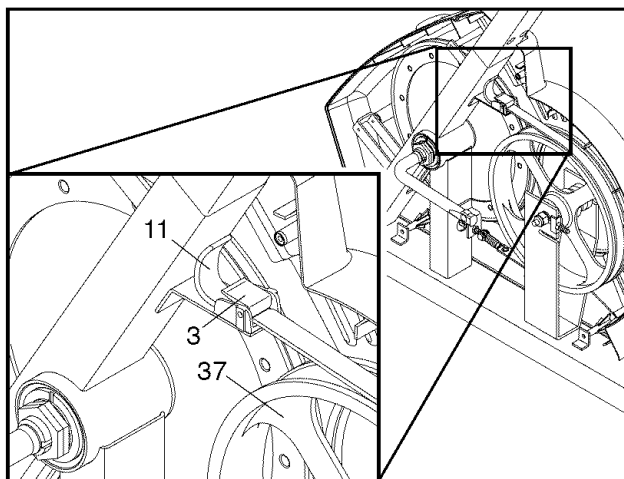

When the resistance strap is properly adjusted, reattach the left side shield and the left pedal.

## HOW TO ADJUST THE REED SWITCH

If the console does not display correct feedback, the reed switch should be adjusted. In order to adjust the reed switch, the left side shield must be removed (see HOW TO ADJUST THE RESISTANCE STRAP on page 10).

With the left side shield removed, locate the Reed Switch (43). Turn the Crank (21) until the Magnet (38) is aligned with the Reed Switch. Loosen, but do not remove, the M4 x 16mm Screw (49). Slide the Reed Switch slightly closer to or away from the Magnet. Retighten the Screw. Turn the Crank for a moment. Repeat until the console displays correct feedback. When the Reed Switch is correctly adjusted, reattach the left side shield and the left pedal.

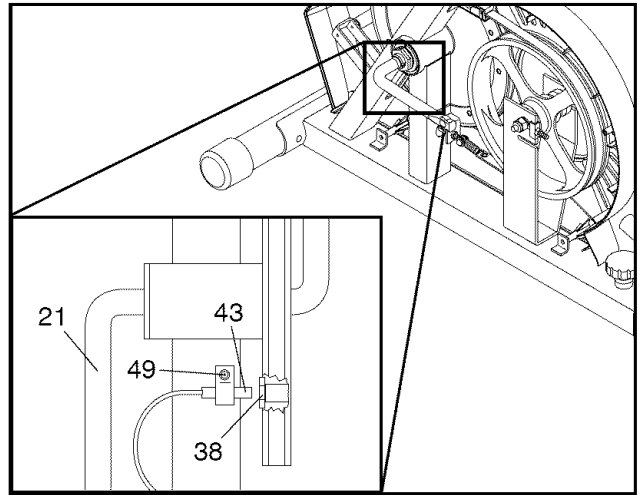

# CONDITIONING GUIDELINES

The following guidelines will help you to plan your exercise program. Remember that proper nutrition and adequate rest are essential for successful results.

**⚠ WARNING:** Before beginning this or any exercise program, consult your physician. This is especially important for persons over the age of 35 or persons with pre-existing health problems.

## EXERCISE INTENSITY

Whether your goal is to burn fat or to strengthen your cardiovascular system, the key to achieving the desired results is to exercise with the proper intensity. The proper intensity level can be found by using your heart rate as a guide. The chart below shows recommended heart rates for fat burning, maximum fat burning, and cardiovascular (aerobic) exercise.

165	155	145	140	130	125	115	♥
145	138	130	125	118	110	103	♥
125	120	115	110	105	95	90	♥
<hr/>							
20	30	40	50	60	70	80	

To find the proper heart rate for you, first find your age at the bottom line of the chart (ages are rounded off to the nearest ten years). Next, find the three numbers above your age. The three numbers are your “training zone.” The lowest number is the recommended heart rate for fat burning; the middle number is the recommended heart rate for maximum fat burning; the highest number is the recommended heart rate for aerobic exercise.

### Fat Burning

To burn fat effectively, you must exercise at a relatively low intensity level for a sustained period of time. During the first few minutes of exercise, your body uses easily accessible carbohydrate calories for energy. Only after the first few minutes of exercise does your body begin to use stored fat calories for energy. If your goal is to burn fat, adjust the intensity of your exercise until your heart rate is near the lowest num-

ber in your training zone as you exercise. For maximum fat burning, adjust the intensity of your exercise until your heart rate is near the middle number in your training zone as you exercise.

### Aerobic Exercise

If your goal is to strengthen your cardiovascular system, your exercise must be “aerobic.” Aerobic exercise is activity that requires large amounts of oxygen for prolonged periods of time. This increases the demand on the heart to pump blood to the muscles, and on the lungs to oxygenate the blood. For aerobic exercise, adjust the intensity of your exercise until your heart rate is near the highest number in your training zone.

### HOW TO MEASURE YOUR HEART RATE

To measure your heart rate, first exercise for at least four minutes. Then, stop exercising and place two fingers on your wrist as shown. Take a six-second heartbeat count, and multiply the result by 10 to find your heart rate. For example, if your six-second heartbeat count is 14, your heart rate is 140 beats per minute. (A six-second count is used because your heart rate will drop rapidly when you stop exercising.)

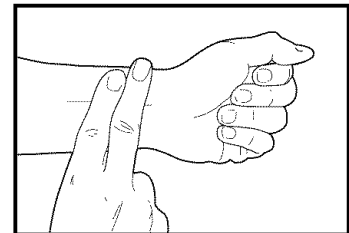

### WORKOUT GUIDELINES

Each workout should include the following three parts:

**A warm-up**, consisting of 5 to 10 minutes of stretching and light exercise. A proper warm-up increases your body temperature, heart rate, and circulation in preparation for exercise.

**Training zone exercise**, consisting of 20 to 30 minutes of exercising with your heart rate in your training zone. Note: During the first few weeks of your exercise program, do not keep your heart rate in your training zone for longer than 20 minutes.

**A cool-down**, with 5 to 10 minutes of stretching. This will increase the flexibility of your muscles and will help to prevent post-exercise problems.

## EXERCISE FREQUENCY

To maintain or improve your condition, plan three workouts each week, with at least one day of rest between

workouts. After a few months of regular exercise, you may complete up to five workouts each week, if desired. Remember, the key to success is make exercise a regular and enjoyable part of your everyday life.

## SUGGESTED STRETCHES

The correct form for several basic stretches is shown at the right. Move slowly as you stretch—never bounce.

### 1. Toe Touch Stretch

Stand with your knees bent slightly and slowly bend forward from your hips. Allow your back and shoulders to relax as you reach down toward your toes as far as possible. Hold for 15 counts, then relax. Repeat 3 times. Stretches: Hamstrings, back of knees and back.

### 2. Hamstring Stretch

Sit with one leg extended. Bring the sole of the opposite foot toward you and rest it against the inner thigh of your extended leg. Reach toward your toes as far as possible. Hold for 15 counts, then relax. Repeat 3 times for each leg. Stretches: Hamstrings, lower back and groin.

### 3. Calf/Achilles Stretch

With one leg in front of the other, reach forward and place your hands against a wall. Keep your back leg straight and your back foot flat on the floor. Bend your front leg, lean forward and move your hips toward the wall. Hold for 15 counts, then relax. Repeat 3 times for each leg. To cause further stretching of the achilles tendons, bend your back leg as well. Stretches: Calves, achilles tendons and ankles.

### 4. Quadriceps Stretch

With one hand against a wall for balance, reach back and grasp one foot with your other hand. Bring your heel as close to your buttocks as possible. Hold for 15 counts, then relax. Repeat 3 times for each leg. Stretches: Quadriceps and hip muscles.

### 5. Inner Thigh Stretch

Sit with the soles of your feet together and your knees outward. Pull your feet toward your groin area as far as possible. Hold for 15 counts, then relax. Repeat 3 times. Stretches: Quadriceps and hip muscles.

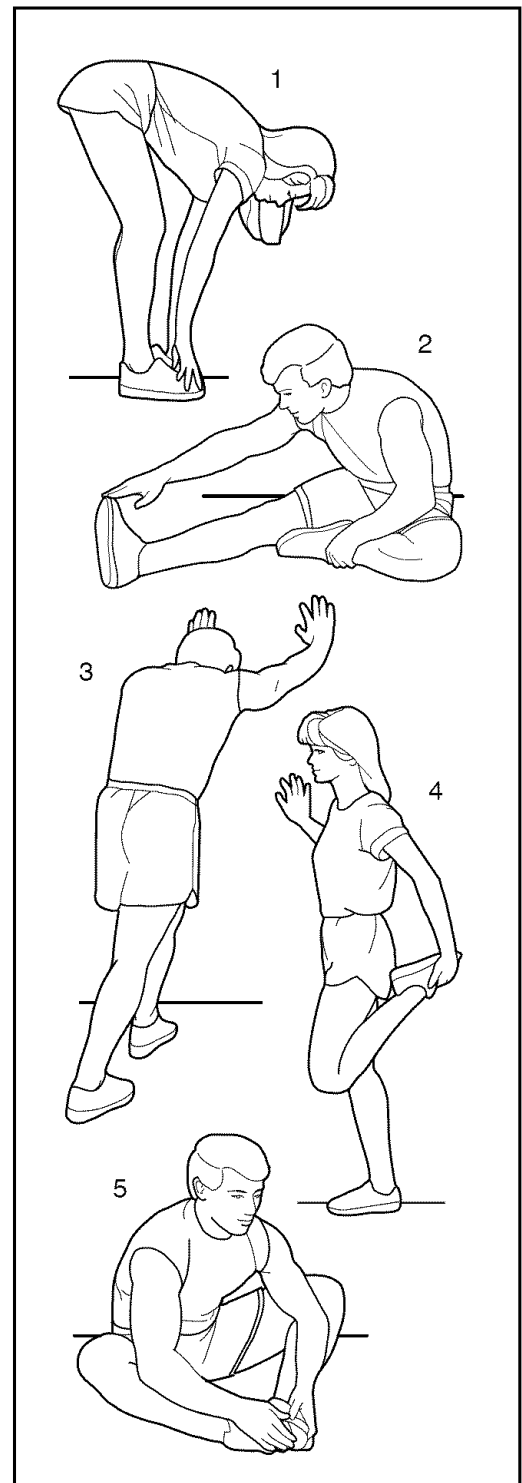

# EXPLODED DRAWING—Model No. WLEX19820

R0802A

Key No.	Qty.	Description	Key No.	Qty.	Description
1	1	Frame	35	1	Belt
2	2	Stabilizer	36	1	Axle Washer
3	1	Strap Clamp	37	1	Flywheel
4	4	Stabilizer Endcap	38	1	Magnet
5	1	Seat Frame	39	1	Flywheel Axle
6	3	M4 x 16mm Self-tapping Screw	40	1	6200Z Bearing
7	4	Handlebar Endcap	41	5	M4 x 25mm Screw
8	4	Foam Grip	42	5	M8 Split Washer
9	1	Adjustment Knob	43	1	Reed Switch/Wire
10	5	M8 Nylon Locknut	44	1	Crank Bearing Set
11	1	Resistance Strap	45	1	Lower Cable
12	1	Seat	46	1	Cable Clamp
13	1	Upright	47	1	Return Spring
14	4	M8 Washer	48	1	Hook
15	1	Handlebar	49	8	M4 x 16mm Screw
16	1	Console	50	2	Seat Handle
17	1	Left Side Shield	51	1	Inner Frame Bushing
18	1	Right Side Shield	52	1	Left Seat Bracket
19	1	Resistance Control/Cable	53	1	Right Seat Bracket
20	1	Seat Frame Bushing	54	1	Backrest
21	1	Crank/Pulley	55	4	Seat Bracket Endcap
22	1	Reed Switch Clamp	56	1	Seat Frame Endcap
23	1	M10 Washer	57	2	M8 x 125mm Bolt
24	1	Left Pedal	58	2	Pedal Strap
25	1	6000Z Bearing	59	2	M8 x 48mm Bolt
26	1	Right Pedal	60	8	M6 x 38mm Screw
27	1	Resistance Knob	61	8	M6 Washer
28	2	U-bracket	62	4	M6 x 32mm Bolt
29	1	Crank Nut	63	4	M6 Nylon Locknut
30	4	M10 x 65mm Carriage Bolt	64	2	M4 x 8mm Screw
31	2	Eyebolt	65	2	M4 x 5mm Screw
32	2	M6 Nut	66	2	Bumper
33	4	M10 Nylon Locknut	#	1	User's Manual
34	3	M8 x 15mm Button Screw	#	2	Allen Wrench

Note: “#” indicates a non-illustrated part. Specifications are subject to change without notice. See the back cover of this manual for information about ordering replacement parts.

# EXPLODED DRAWING—Model No. WLEX19820

R0802A

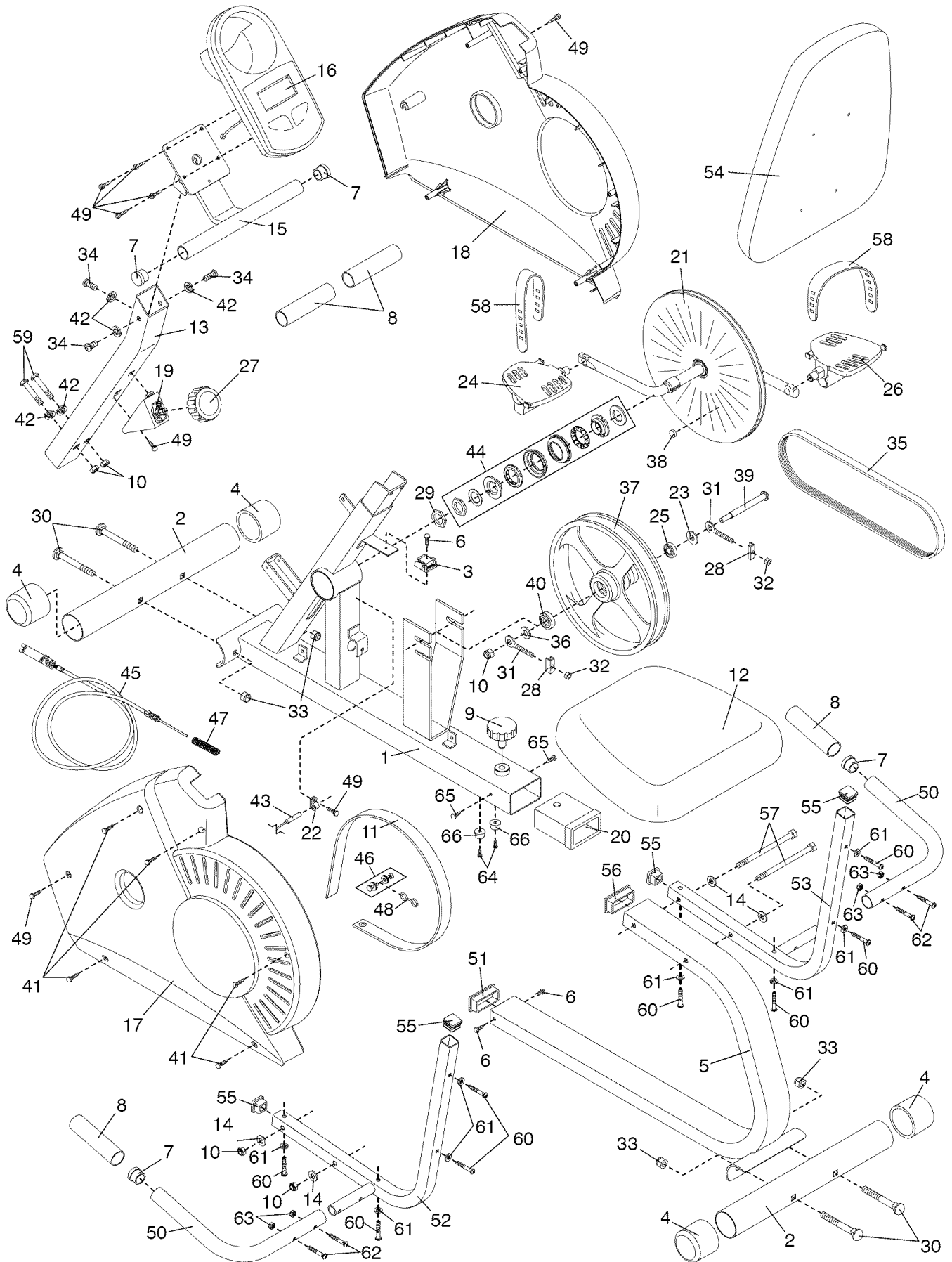

---

# ORDERING REPLACEMENT PARTS

To order replacement parts, call our Customer Service Department toll-free at 1-800-999-3756, Monday through Friday, 6 a.m. until 6 p.m. Mountain Time (excluding holidays). To help us assist you, please be prepared to give the following information:

- The MODEL NUMBER of the product (WLEX19820)
- The NAME of the product (WESLO® PURSUIT 510 CS exercise cycle)
- The SERIAL NUMBER of the product (see the front cover of this manual)
- The KEY NUMBER and DESCRIPTION of the part(s) (see the PART LIST on page 14)

WESLO is a registered trademark of ICON Health & Fitness, Inc.

## LIMITED WARRANTY

ICON Health & Fitness, Inc. (ICON), warrants this product to be free from defects in workmanship and material, under normal use and service conditions, for a period of ninety (90) days from the date of purchase. This warranty extends only to the original purchaser. ICON's obligation under this warranty is limited to replacing or repairing, at ICON's option, the product through one of its authorized service centers. All repairs for which warranty claims are made must be pre-authorized by ICON. This warranty does not extend to any product or damage to a product caused by or attributable to freight damage, abuse, misuse, improper or abnormal usage or repairs not provided by an ICON authorized service center, products used for commercial or rental purposes, or products used as store display models. No other warranty beyond that specifically set forth above is authorized by ICON.

ICON is not responsible or liable for indirect, special or consequential damages arising out of or in connection with the use or performance of the product or damages with respect to any economic loss, loss of property, loss of revenues or profits, loss of enjoyment or use, costs of removal, installation or other consequential damages of whatsoever nature. Some states do not allow the exclusion or limitation of incidental or consequential damages. Accordingly, the above limitation may not apply to you.

The warranty extended hereunder is in lieu of any and all other warranties and any implied warranties of merchantability or fitness for a particular purpose is limited in its scope and duration to the terms set forth herein. Some states do not allow limitations on how long an implied warranty lasts. Accordingly, the above limitation may not apply to you.

This warranty gives you specific legal rights. You may also have other rights which vary from state to state.

**ICON HEALTH & FITNESS, INC., 1500 S. 1000 W., LOGAN, UT 84321-9813**