



Owner's Guide

Projection Television Models
WD-52327, WD-62327



visit our website at
www.mitsubishi-tv.com



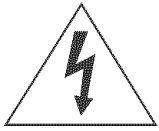

CAUTION

RISK OF ELECTRIC SHOCK DO NOT OPEN

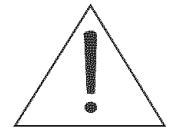

CAUTION:

**TO REDUCE THE RISK OF ELECTRIC SHOCK, DO NOT REMOVE COVER OR BACK.
NO USER SERVICEABLE PARTS INSIDE.
REFER SERVICING TO QUALIFIED SERVICE PERSONNEL.**



The lightning flash with arrowhead symbol within an equilateral triangle is intended to alert the user of the presence of uninsulated “dangerous voltage” within the product’s enclosure that may be sufficient magnitude to constitute a risk of electric shock.

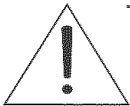

The exclamation point within an equilateral triangle is intended to alert the user to the presence of important operating and maintenance (service) instructions in the literature accompanying the appliance.

Note: This equipment has been tested and found to comply with the limits for a Class B digital device, pursuant to part 15 of the FCC Rules. These limits are designed to provide reasonable protection against harmful interference in a residential installation. This equipment generates, uses and can radiate radio frequency energy and, if not installed and used in accordance with the instructions, may cause harmful interference to radio communications. However, there is no guarantee that interference will not occur in a particular installation. If this equipment does cause harmful interference to radio or television reception, which can be determined by turning the equipment off and on, the user is encouraged to try to correct the interference by one or more of the following measures:

- Reorient or relocate the receiving antenna.
- Increase the separation between the equipment and the receiver.
- Connect the equipment into an outlet on a circuit different from that to which the receiver is connected.
- Consult the dealer or an experienced radio/TV technician for help.

STAND REQUIREMENT

CAUTION: Mitsubishi TV model WD-52327 is for use only with Mitsubishi stand, model MB-52525. Mitsubishi TV model WD-62327 is for use only with Mitsubishi stand model MB-62525. Use with other stands may result in instability causing possible injury.

LAMP COOL DOWN

It is very important that you connect your TV directly to a wall outlet that has constant power. Your TV’s internal fan must properly cool the TV’s lamp once the TV is powered down. If there is not constant power to your TV or it is powered completely off by a switch or component, the TV’s lamp life may be shortened or damaged. This “cool down” period is common with all microdisplay projection televisions.

CAUTION: To assure continued FCC compliance, the user must use a shielded video interface cable with bonded ferrite cores at both ends, when using the MonitorLink/DVI input.

Changes or modifications not expressly approved by Mitsubishi could void the user’s authority to operate this equipment.

WARNING:

TO REDUCE THE RISK OF FIRE OR ELECTRIC SHOCK, DO NOT EXPOSE THIS APPLIANCE TO RAIN OR MOISTURE.

CAUTION:

TO PREVENT ELECTRIC SHOCK, MATCH WIDE BLADE OF PLUG TO WIDE SLOT, FULLY INSERT.

NOTE TO CATV SYSTEM INSTALLER:

THIS REMINDER IS PROVIDED TO CALL THE CATV SYSTEM INSTALLER’S ATTENTION TO ARTICLE 820-40 OF THE NEC THAT PROVIDES GUIDELINES FOR THE PROPER GROUNDING AND, IN PARTICULAR, SPECIFIES THAT THE CABLE GROUND SHALL BE CONNECTED TO THE GROUNDING SYSTEM OF THE BUILDING, AS CLOSE TO THE POINT OF CABLE ENTRY AS PRACTICAL.

Contents

Chapter 1 Television Overview

TV Accessories.....	8
Special Features.....	8
Front Control Panel	9
Back Panel Input/Output.....	10

Chapter 2 Connecting

Antenna	12
Wall Outlet Cable.....	12
Antenna to a Cable Box.....	13
Antenna to a VCR.....	13
Antenna to a Cable Box and VCR	14
Composite Video or S-Video (Recommended) with Audio	14
Stereo Audio System.....	15
Audio Receiver	15
DVD Player.....	16
Other S-Video Device.....	16
DTV Receiver.....	17
MonitorLink™/DVI	19
How Connections Affect the PIP and POP	20

Chapter 3 Remote Control Functions

Overview of the TV Layer Buttons.....	22
Care and Operation.....	23
Channel Selection	24
Sleep Timer	24
Use With Other A/V Products	25
Special Functions	27
Operation of PIP and POP.....	28

Chapter 4 Menu Screen Operations

The ViewPoint® Menu System.....	30
MAIN Menu	31
SETUP Menu.....	33
CAPTIONS Menu.....	37
CHANNEL EDIT Menu.....	39
V-CHIP LOCK Menu.....	42
ADVANCED FEATURES Menu	46
AUDIO/VIDEO SETTINGS Menu	50

Chapter 5 PIP/POP Operations

Available On-Screen Format Sizes	54
Operation of PIP and POP.....	56
Appendix A: Bypassing the V-Chip Lock.....	57
Appendix B: HD Input Connection Compatibility.....	59
Appendix C: Remote Control Programming Codes.....	60
Appendix D: Cleaning and Service	62
Appendix E: Cleaning the Dust Filter	63
Appendix F: Lamp Cartridge Replacement.....	64
Troubleshooting.....	66
Additional Information	68
Index.....	69

IMPORTANT SAFEGUARDS

Please read the following safeguards for your TV and retain for future reference.

Always follow all warnings and instructions marked on the television.

1. Read, Retain and Follow All Instructions

Read all safety and operating instructions before operating the TV. Retain the safety and operating instructions for future reference. Follow all operating and use instructions.

2. Heed Warnings

Adhere to all warnings on the appliance and in the operating instructions.

3. Cleaning

Unplug the TV from the wall outlet before cleaning. Do not use liquid, abrasive, or aerosol cleaners. Cleaners can permanently damage the cabinet and screen. Use a lightly dampened cloth for cleaning.

4. Attachments and Equipment

Never add any attachments and/or equipment without approval of the manufacturer as such additions may result in the risk of fire, electric shock or other personal injury.

5. Water and Moisture

Do not use the TV where contact with or immersion in water is possible. Do not use near bath tubs, wash bowls, kitchen sinks, laundry tubs, swimming pools, etc.

6. Accessories



Do not place the TV on an unstable cart, stand, tripod, or table. The TV may fall, causing serious injury to a child or adult and serious damage to the TV. Use only with a cart, stand, tripod, bracket, or table recommended by the manufacturer, or sold with the TV. Any mounting of the TV should follow the manufacturer's instructions, and should use mounting accessories recommended by the manufacturer.

An appliance and cart combination should be moved with care. Quick stops, excessive force, and uneven surfaces may cause the appliance and cart combination to overturn.

7. Ventilation

Slots and openings in the cabinet are provided for ventilation and to ensure reliable operation of the TV and to protect it from overheating. Do not block these openings or allow them to be obstructed by placing the TV on a bed, sofa, rug, or other similar surface. Nor should it be placed over a radiator or heat register. If the TV is to be placed in a rack or bookcase, ensure that there is adequate ventilation and that the manufacturer's instructions have been adhered to.

8. Power Source

This TV should be operated only from the type of power source indicated on the marking label. If you are not sure of the type of power supplied to your home, consult your appliance dealer or local power company.

9. Grounding or Polarization

This TV is equipped with a polarized alternating current line plug having one blade wider than the other. This plug will fit into the power outlet only one way. If you are unable to insert the plug fully into the outlet, try reversing the plug. If the plug should still fail to fit, contact your electrician to replace your obsolete outlet. Do not defeat the safety purpose of the polarized plug.

10. Power-Cord Protection

Power-supply cords should be routed so that they are not likely to be walked on or pinched by items placed upon or against them, paying particular attention to cords at plugs, convenience receptacles, and the point where they exit from the TV.

11. Lightning

For added protection for this TV during a lightning storm, or when it is left unattended and unused for long periods of time, unplug it from the wall outlet and disconnect the antenna or cable system. This will prevent damage to the TV due to lightning and power-line surges.

12. Power Lines

An outside antenna system should not be located in the vicinity of overhead power lines or other electric light or

IMPORTANT SAFEGUARDS, continued

power circuits, or where it can fall into such power lines or circuits. When installing an outside antenna system, extreme care should be taken to keep from touching such power lines or circuits as contact with them might be fatal.

13. Overloading

Do not overload wall outlets and extension cords as this can result in a risk of fire or electric shock.

14. Object and Liquid Entry

Never push objects of any kind into this TV through openings as they may touch dangerous voltage points or short-out parts that could result in fire or electric shock. Never spill liquid of any kind on or into the TV.

15. Outdoor Antenna Grounding

If an outside antenna or cable system is connected to the TV, be sure the antenna or cable system is grounded so as to provide some protection against voltage surges and built-up static charges.

Article 810 of the National Electric Code, ANSI/NFPA No. 70-2002, provides information with respect to proper grounding of the mast and supporting structure, grounding of the lead in wire to an antenna discharge unit, size of grounding conductors, location of antenna discharge unit, connection to grounding electrodes, and requirements for the grounding electrode.

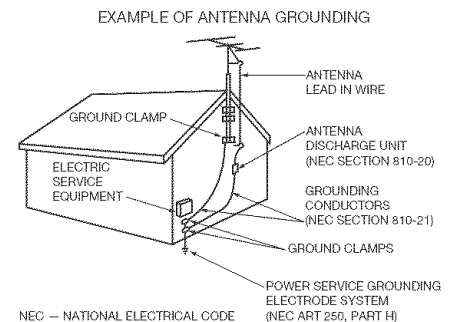

16. Servicing

Do not attempt to service this TV yourself as opening or removing covers may expose you to dangerous voltage or other hazards. Refer all servicing to qualified service personnel.

17. Damage Requiring Service

Unplug the TV from the wall outlet and refer servicing to qualified service personnel under the following conditions:

- (a) When the power-supply cord or plug is damaged.
- (b) If liquid has been spilled, or objects have fallen into the TV.
- (c) If the TV has been exposed to rain or water.
- (d) If the TV does not operate normally by following the operating instructions, adjust only those controls that are covered by the operating instructions as an improper adjustment of other controls may result in damage and will often require extensive work by a qualified technician to restore the TV to its normal operation.
- (e) If the TV has been dropped or the cabinet has been damaged.
- (f) When the TV exhibits a distinct change in performance - this indicates a need for service.

18. Replacement Parts

When replacement parts are required, be sure the service technician has used replacement parts specified by the manufacturer or have the same characteristics as the original part. Unauthorized substitutions may result in fire, electric shock or other hazards.

19. Safety Check

Upon completion of any service or repair to the TV, ask the service technician to perform safety checks to determine that the TV is in safe operating condition.

20. Heat

The product should be situated away from heat sources such as radiators, heat registers, stoves, or other products (including amplifiers) that produce heat.

Thank You for Your Purchase

Welcome to the wonderful and exciting world of digital television! We are honored that you chose Mitsubishi as your premier home entertainment partner. The development team at Mitsubishi Digital Electronics America (MDEA) understands that our customers demand and expect the very best.

MDEA was founded on the core beliefs and philosophies that drive us to deliver products that implement the latest in advanced television technology.

While some televisions are destined for obsolescence in the near future, MDEA's televisions are all HD-upgradeable. This cornerstone of your home entertainment system will continue to provide unparalleled enjoyment for years to come!

Whether this is your first Mitsubishi consumer electronics product or another addition to your growing Mitsubishi system, we hope that this television will bring you many hours of enjoyment.

Chapter

1

Television Overview

TV Accessories	8
Special Features	8
Front Control Panel.....	9
Back Panel Input/Output	10

TV Accessories

Please take a moment to review the following list of items to ensure that you have received everything including:



Remote Control

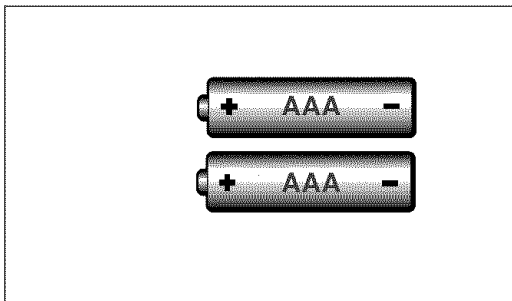

2 AAA Batteries

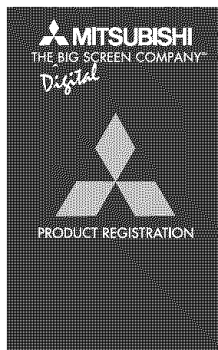

Product Registration Card

Owner's Guide (not pictured)

Quick Reference Card (not pictured)

Special Features

Your new High Definition (HD) upgradeable widescreen television has many special features that make it the perfect addition to your home entertainment system. These special features include:

High Definition DLP™ Display System

Your widescreen Mitsubishi HDTV uses Texas Instruments Digital Light Processing™ technology. This TV is truly a high performance multimedia monitor uniquely capable of stunning high definition video images. Your TV is able to accept video signals in the standard video scanning rates of 480i, 480p, and 1080i.

PIP/POP Viewing Option

Using Picture-in-Picture and Picture-outside-Picture gives you exciting options for viewing favorite programs.

HD Upgradeable

With the use of an optional HDTV receiver (Mitsubishi HD-6000 or similar model), your Mitsubishi bigscreen can display high definition pictures.

Multibrand Remote Control

Your Mitsubishi remote control can be programmed to control many other audio/video components.

V-Chip Technology

Mitsubishi understands you may want to shield certain viewers from specific program content. Your Mitsubishi bigscreen will allow you to restrict programming by general contents, specific contents, or even by time.

16:9 Widescreen TV

Enjoy a full theatrical experience in the comfort of your home. View pictures as film directors intended them. DTV, DVD and newer video game consoles support the widescreen format and are well-suited for your new TV.

Air Circulation Tip

When considering the location or position of your TV, we recommend that you place it at least 2" (inches) away from the wall. Like most electrical equipment and appliances, better air circulation allows your television's lamp to run cooler, assuring a longer, trouble-free life.

Front Control Panel

The buttons on the Front Control Panel highlighted in gray are duplicated on the remote control. The top row of labels show the control functions when there are no TV menus displayed on the screen. The bottom row of labels show the control functions when the TV menus are displayed on the screen or when a special function has been activated. See *Remote Control Overview*, for further details on the functions of these buttons.

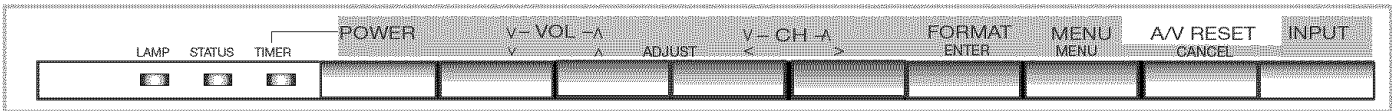

Indicators

Please refer to the table below for conditions when the indicator lights will display.

COLOR	LAMP INDICATOR	STATUS INDICATOR	TIMER/POWER
None (off)	Power off	Power off	Power off
Green (steady light)	n/a	n/a	Power on
Green (blinking light)	Power just turned off, TV cooling down (1 minute). Cannot turn the TV back on until blinking stops.	n/a	TV Timer is set
Yellow (steady light)	Lamp life end warning. A new lamp should be purchased. See Appendix F.	Operating temperature is too high. The dust filter may be dirty. See Appendix E. or The room temperature too hot. Turn off TV until the room is cooler.	n/a
Yellow (blinking light)	Lamp cover door is open or no lamp installed. See Appendix F.	The filter cover is open or not secure. See Appendix E.	n/a
Red (steady light)	Lamp has failed, replacement is required. See Appendix F.	Service required. Turn off TV and call your dealer or a Mitsubishi Authorized Service Center. See www.mitsubishitv.com or call 1-800-332-2119.	n/a
Red (blinking light)	n/a	Service required. Turn off TV and call your dealer or a Mitsubishi Authorized Service Center. See www.mitsubishitv.com or call 1-800-332-2119.	n/a

A/V Reset

Press this button to reset all A/V memory inputs to the factory default.

Input-3

This input can be used for convenient connection of a camcorder or other video device to the TV. You may connect to the S-VIDEO or VIDEO terminal but not to both.

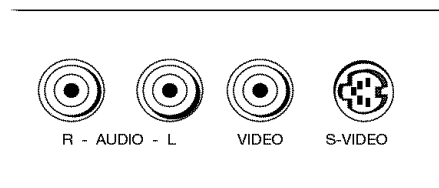

Back Panel Input/Output

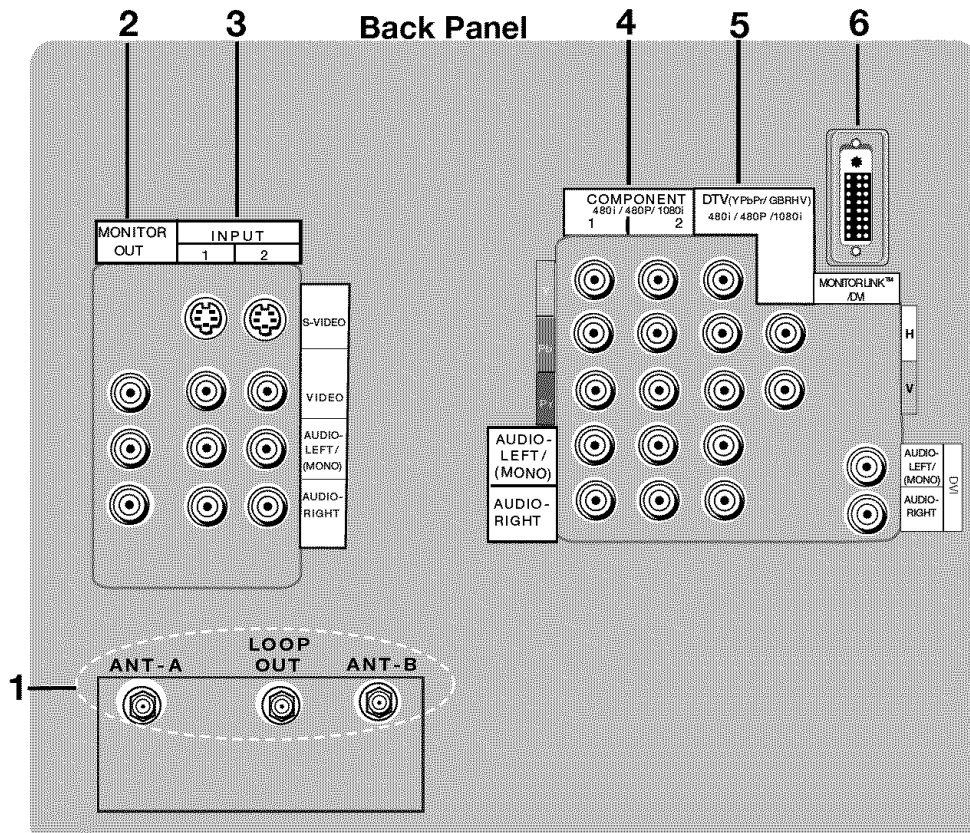

1. ANT-A, LOOP OUT and ANT-B

ANT-A and ANT-B receive signals from VHF/UHF antennas or a cable system. LOOP OUT sends the ANT-A signal out to another device, such as a cable box or VCR.

Note: LOOP OUT is disabled when Energy Mode is set to Low and the TV power is set to Off.

2. Monitor Out

The Monitor Output sends the TV audio and video signals (excluding component video, DTV video and MonitorLink) to an A/V receiver or other equipment.

3. Inputs 1-2

These inputs can be used for the connection of a VCR, Super VHS (S-VHS) VCR, laser disc player, or other A/V device to the TV. With each input, you may connect to the S-VIDEO or VIDEO terminal but not to both.

4. Component Inputs 1-2

These inputs can be used for the connection of A/V equipment with component video outputs, such as a DVD player, DTV receiver or compatible Video Game System. Please see Appendix B, page 59, for signal compatibility.

5. DTV Input

This input is used to connect a DTV receiver or cable box and can be configured for HDTV component (YPbPr), or RGB plus H&V. Please see Appendix B, page 59, for signal compatibility.

6. MonitorLink™/DVI

This is a Mitsubishi-exclusive proprietary digital interface for the display of high quality digital video signals from Mitsubishi products such as the HD-5000 HDTV Receiver/Controller. All video signals, both analog and digital are sent digitally to your Mitsubishi TV. Can also be used as a DVI (HDCP) input for other compatible sources.

Note: The DVI-HDTV input terminal is compliant with the EIA-861 standard. It is not intended for use with personal computers or devices outputting video signals with computer resolution.

Chapter

2

Connecting

Antenna.....	12
Wall Outlet Cable	12
Antenna to a Cable Box.....	13
Antenna to a VCR.....	13
Antenna to a Cable Box and VCR.....	14
Composite Video or S-Video (Recommended) with Audio.....	14
Stereo Audio System	15
Audio Receiver	15
DVD Player	16
Other S-Video Device	16
DTV Receiver	17
MonitorLink™/DVI.....	19
How Connections Affect the PIP and POP.....	20

IMPORTANT

Additional connection cables are not provided with the TV. They should be available at most electronic stores.

Connecting an Antenna or Wall Outlet Cable

Separate UHF and VHF Antennas

(Figure 1)

1. Connect the UHF and VHF antenna leads to the UHF/VHF combiner.
2. Push the combiner onto ANT-A on the TV back panel.

UHF/VHF combiners are not provided with the TV. They are available at most electronic stores.

Note: This TV will only be able to provide an analog signal through ANT-A on the TV back panel.

See page 5 for Outdoor Antenna Grounding information.

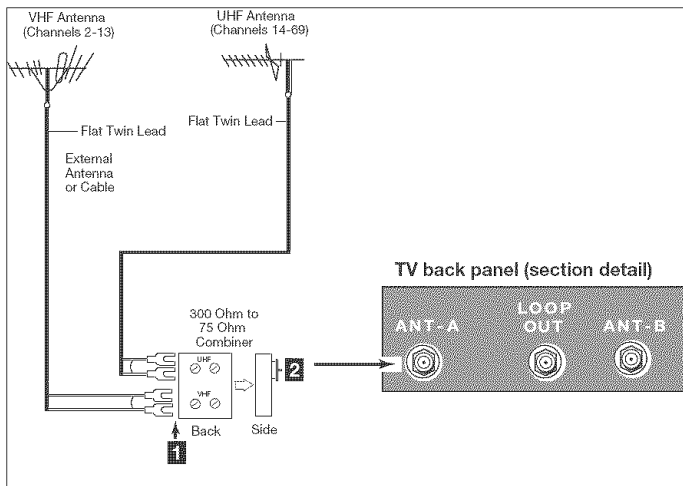

Figure 1. Connecting separate UHF and VHF antennas.

Twin Lead Antenna, Coaxial Lead Antenna, or Wall Outlet Cable

(Figure 2)

For antenna with twin flat leads:

1. Connect the 300 Ohm twin leads to the transformer.
2. Push the 75 Ohm side of the transformer onto ANT-A on the TV back panel.

300 Ohm to 75 Ohm matching transformers are not provided with the TV. They are available at most electronic stores.

For cable or antenna with coaxial lead:

3. Connect the incoming cable to ANT-A on the TV back panel.

Note: This TV will only be able to provide an analog signal through ANT-A on the TV back panel.

See page 5 for Outdoor Antenna Grounding information.

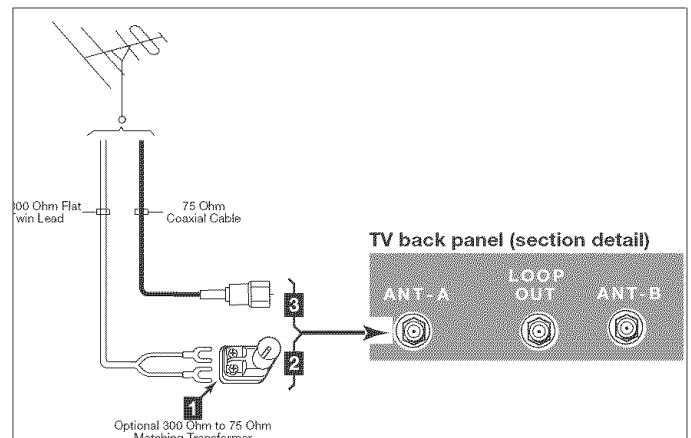

Figure 2. Connecting twin lead antenna, coaxial lead antenna, or wall outlet cable.

IMPORTANT

Additional connection cables are not provided with the TV. They should be available at most electronic stores.

Mitsubishi strongly recommends against using antennas with twin flat leads. Twin flat lead antenna wires are subject to interference which may adversely affect the performance of the TV. We recommend using coaxial antenna cable.

Connecting an Antenna to a Cable Box or VCR

Antenna to a Cable Box

(Figure 3)

1. Connect the incoming cable to ANT-A on the TV back panel.

Connect two coaxial cables as follows:

2. One from LOOP-OUT on the TV back panel to IN on the cable box back panel.
3. One from OUT on the cable box back panel to ANT-B on the TV back panel.

Note: If your cable box has separate audio/video outputs, connect the audio as shown in Figure 6, page 14.

Antenna to a VCR

(Figure 4)

1. Connect the incoming cable to ANT-A on the TV back panel.

Connect two coaxial cables as follows:

2. One from LOOP-OUT on the TV back panel to ANTENNA IN on the VCR back panel.
3. One from VCR back panel ANTENNA OUT to ANT-B on the TV back panel.

Note: If your VCR has separate audio/video outputs, connect the audio as shown in Figure 6, page 14.

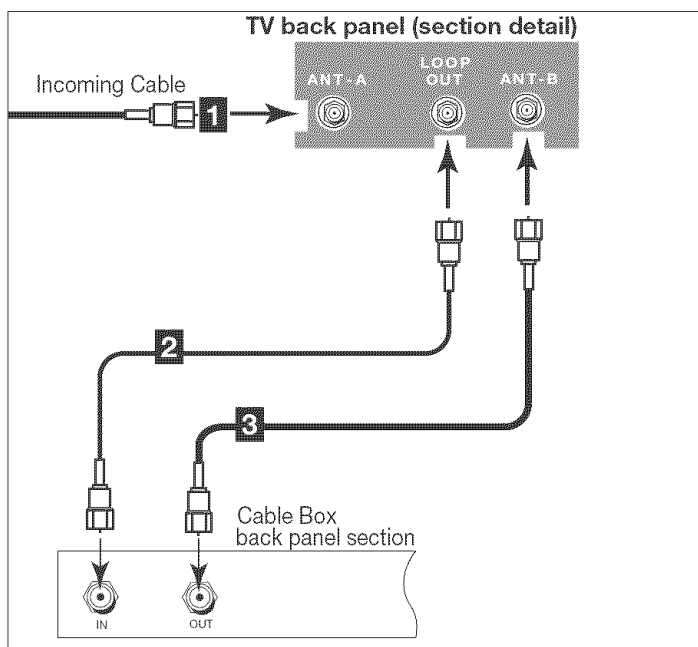

Figure 3. Connecting the cable box.

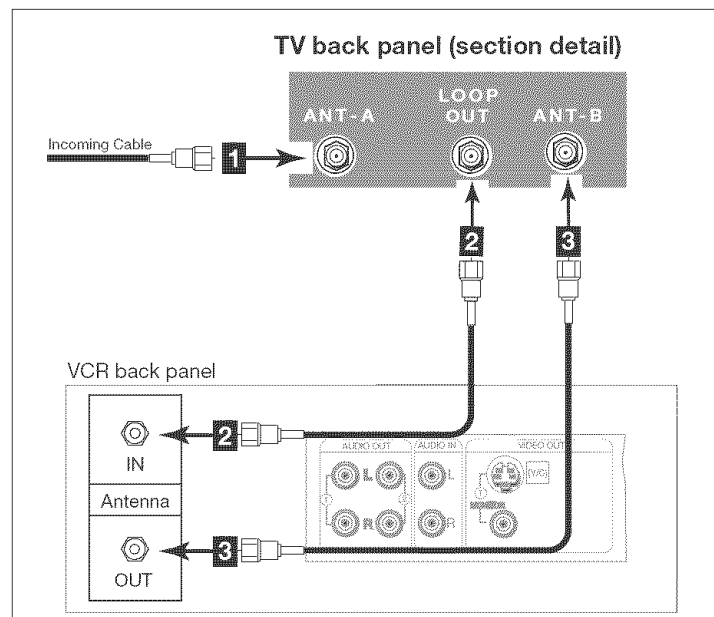

Figure 4. Connecting the VCR with antenna or wall outlet cable.

Note: When the Energy Mode is set to Low, the VCR may not record programs when the TV is off.

Note: For digital cable boxes, refer to your Digital Cable Box owner's guide for instructions on optimal connections to this TV.

Connecting an Antenna to a Cable Box and VCR, Connecting Composite Video or S-Video with Audio

Contact your local cable or satellite provider or refer to the cable box or satellite Owner's Guide for instructions on optimal connections to this TV.

Antenna to Cable Box and VCR

(Figure 5)

1. Connect the incoming cable to ANT-A on the TV back panel.

Connect three coaxial cables as follows:

2. One from LOOP-OUT on the TV back panel to IN on the back of the cable box.
3. One from OUT on the back of the cable box to ANTENNA IN on the VCR back panel.
4. One from ANTENNA OUT on the VCR back panel to ANT-B on the TV back panel.

Note: For best performance, connect the audio as shown in Figure 6, page 14.

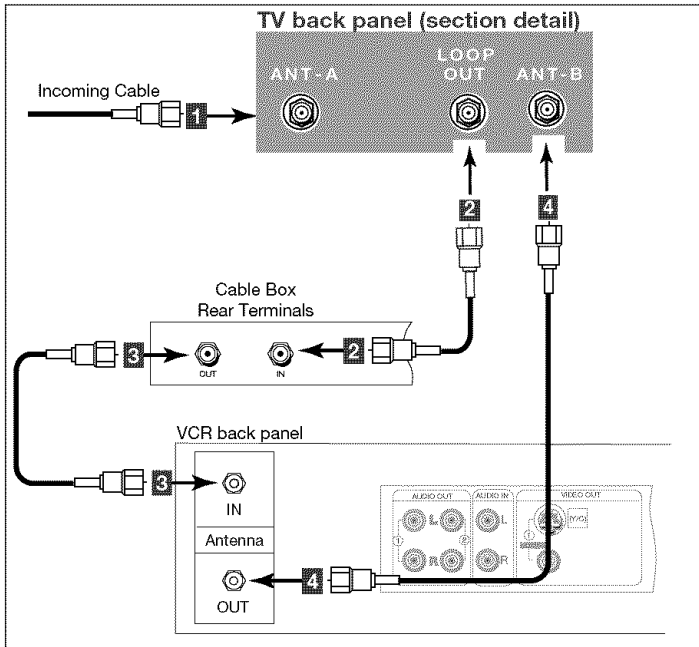

Figure 5. Connecting the VCR with cable box.

Composite Video or S-Video (Recommended) with Audio

(Figure 6)

1. Connect a video or an S-Video cable from VIDEO OUT on the VCR back panel to VIDEO or S-VIDEO, INPUT-1 or INPUT-2 on the TV back panel.
2. Connect a set of audio cables from AUDIO OUT on the VCR back panel to AUDIO INPUT-1 or INPUT-2 on the TV back panel, matching the input used in step 1.

- The red cable connects to the R (right) channel
- The white cable connects to the L (left) channel

If your VCR is mono (non-stereo), connect only the white (left) cable.

You may connect to the S-VIDEO or VIDEO terminal but not to both.

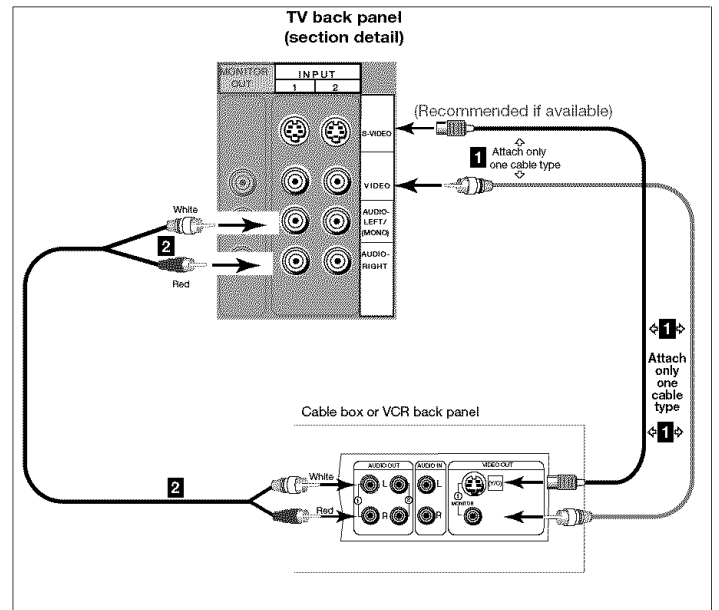

Figure 6. Connecting Composite Video and Audio.

IMPORTANT

Additional connection cables are not provided with the TV. They should be available at most electronic stores.

Connecting a Stereo Audio System

Connecting an Audio Receiver

Stereo Audio System

(Recommended for shelf units or A/V receivers without digital audio inputs)

(Figure 7)

1. Connect the audio cables from AUDIO MONITOR OUTPUT on the TV back panel to TV IN or AUX IN terminals on the back of the audio system.
 - The red cable connects to the R (right) channel
 - The white cable connects to the L (left) channel
2. Use the AUDIO/VIDEO SETTINGS menu (page 50) to turn off the TV's speakers.
3. Set the input of the audio system to the TV or AUX position to hear the TV audio through your stereo system.

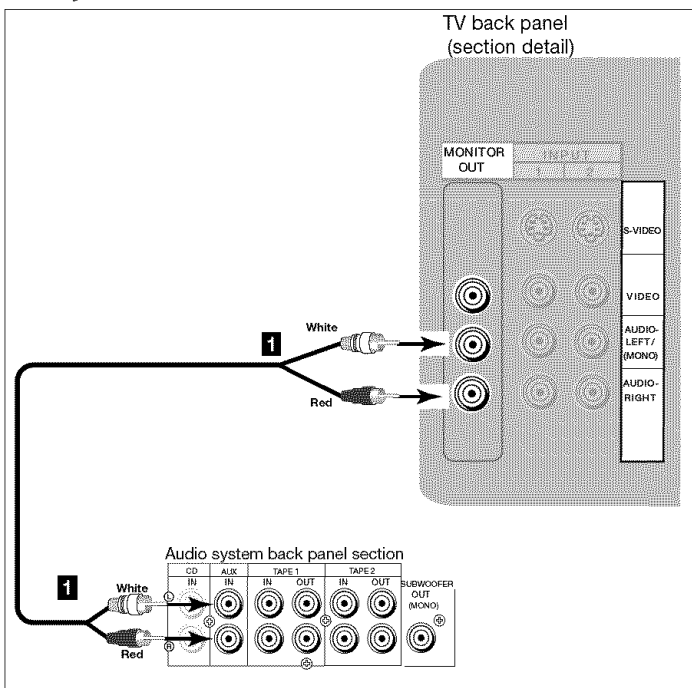

Figure 7. Connecting the Stereo Audio System.

IMPORTANT
 These types of audio connections do NOT support multi-channel digital audio. Please refer to your other devices Owner's Guide to verify.

A/V Receiver

(Figure 8)

1. Connect either a video cable or an S-Video cable (but not both) from VIDEO MONITOR OUTPUT on the back of the A/V receiver to VIDEO INPUT-1 or INPUT-2 on the TV back panel.
2. Connect a video cable from VIDEO MONITOR OUTPUT on the TV back panel to VIDEO TV IN on the back of the A/V receiver.
3. Connect a set of audio cables from AUDIO MONITOR OUTPUT on the TV back panel to AUDIO TV IN on the back of the A/V receiver.

Note: If the A/V receiver outputs an onscreen menu, this connection allows you to view the receiver's menu on the television.

- The red cable connects to the R (right) channel
- The white cable connects to the L (left) channel

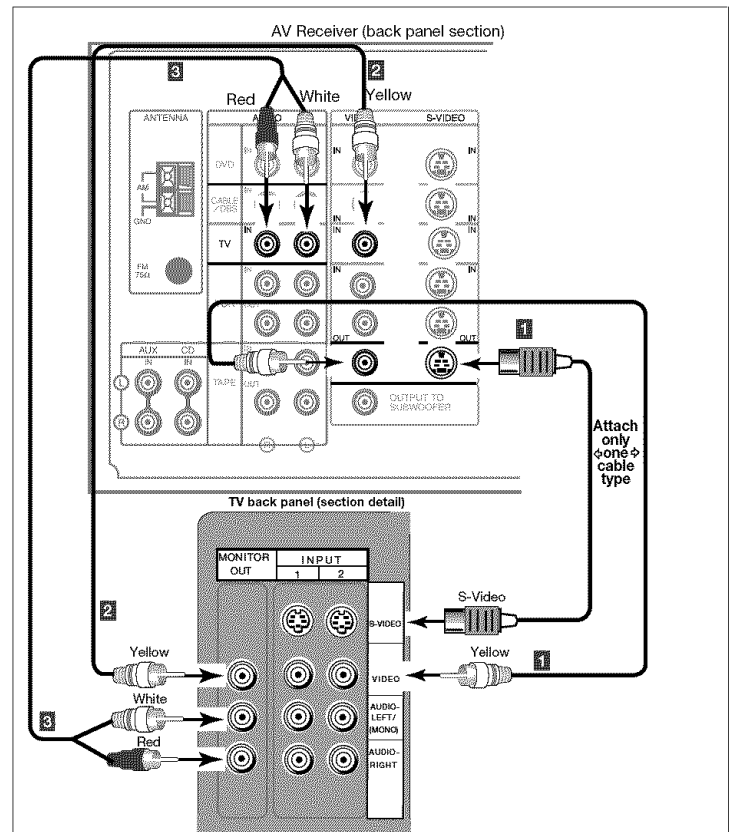

Figure 8. Connecting the A/V Receiver.

Note: Please see your A/V receiver Owner's Guide for more detailed connections.

Connecting a DVD Player or Other S-Video Device

DVD Player with Component Video (Recommended)

(Figure 9)

1. Connect the Component Video cables from (YCbCr or YPbPr) VIDEO OUT on the back of the DVD player to COMPONENT (1 or 2) on the TV back panel. The correct connections are:
 - A. Y to Y
 - B. Cb or Pb to Pb
 - C. Cr or Pr to Pr
2. Connect a set of audio cables from AUDIO OUT on the back of the DVD player to COMPONENT AUDIO Input (1 or 2) on the TV back panel.

- The red cable connects to the R (right) channel
- The white cable connects to the L (left) channel

Note: Some video game systems support DTV resolutions via component connections. Please refer to your video game console Owner's Guide for setup information.

Note: For optimal DVD playback performance, Mitsubishi recommends using a progressive scan DVD player, set to play in progressive scan mode. You will also want to set your player to display 16:9 widescreen. Please refer to your DVD player's Owner's Guide.

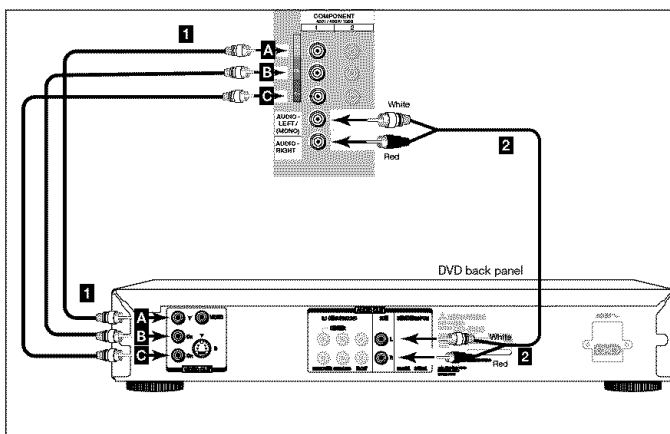

Figure 9. Connecting a DVD Player with Component Video.

Other S-Video Device

(Figure 10)

1. Connect an S-Video cable from VIDEO OUT on the device back panel to VIDEO INPUT-1 or INPUT-2 on the TV back panel.
2. Connect a set of audio cables from AUDIO OUT on the device back panel to AUDIO INPUT-1 or INPUT-2 on the TV back panel, matching the input used in step 1.

- The red cable connects to the R (right) channel
- The white cable connects to the L (left) channel

If your S-Video Device is mono (non-stereo), connect only the white (left) cable.

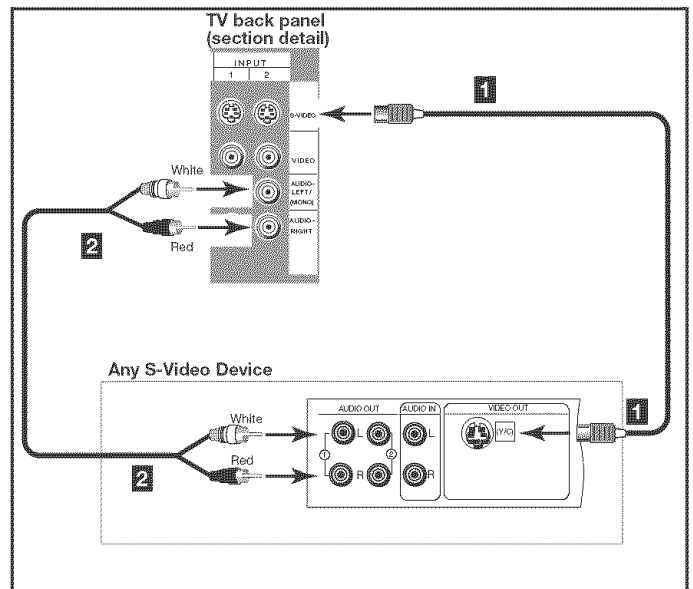

Figure 10. Connecting an S-Video Device.

IMPORTANT

See Appendix B, page 59, for component video signal compatibility information.

For digital audio connections, see your

Connecting a DTV Receiver

Contact your local cable or satellite provider or refer to the cable box or satellite Owner's Guide for instructions on optimal connections to this TV.

DTV Connectors and Adaptors

(Figure 11)

The TV back panel has 5 RCA-type connectors for the DTV connection. The back panel of your DTV receiver may use RCA-type connectors or BNC-type connectors. If your DTV receiver comes with BNC type connections, you will need to purchase BNC to RCA adaptors to connect the TV to the DTV receiver. These adaptors should be available at most electronic supply stores.

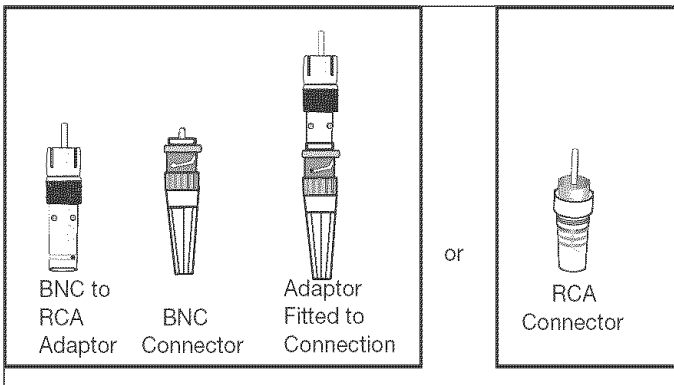

Figure 11. DTV connectors and adaptors.

DTV Receiver with Component Video Connections (Recommended)

(Figure 12)

1. Connect the outside antenna cable, or satellite to ANT or SATELLITE IN on the DTV receiver (see your DTV receiver owner's guide for instructions and cable compatibility).
2. If your DTV receiver has a built-in integrated digital tuner, connect the incoming integrated antenna to ANT on the DTV receiver. If your DTV receiver does not have a built-in terrestrial tuner, this TV will only be able to provide an analog signal through Ant-A or Ant-B on the TV back panel.
3. Connect the RCA-type cables from the DTV receiver outputs to DTV INPUT Y/Pb/Pr on the TV back panel. You may need to access the Input Assignment menu (page 33) to set the DTV Input to Y/Pb/Pr.
4. Connect the L (left) and R (right) audio cables from the DTV receiver to DTV AUDIO on the TV back panel.
5. To utilize the benefits of a digital A/V receiver, connect your DTV receiver's digital audio out to a digital input on your digital A/V receiver. Component (1 and 2) may also be used for 1080i components.

IMPORTANT

See Appendix B, page 59, for component video signal compatibility information.

For digital audio connections, see your DTV and A/V receiver Owner's Guides.

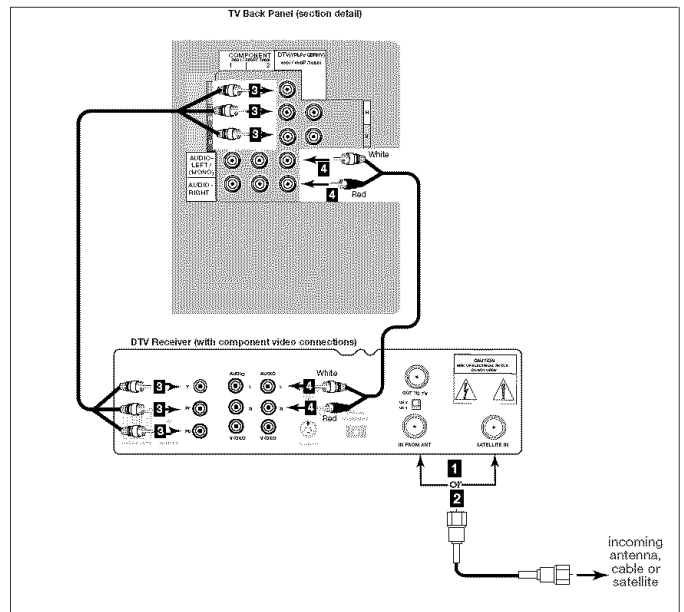

Figure 12. Connecting the DTV receiver with component Video Connections.

Connecting a DTV Receiver, continued

DTV Receiver with RGB Video

Connections

(Figure 13)

1. Connect the outside antenna, cable, or satellite to ANT or SATELLITE IN on the DTV receiver (see your DTV receiver owner's guide for instructions and cable compatibility).
2. If your DTV receiver has a built-in integrated tuner, connect the incoming terrestrial antenna to ANT on the DTV receiver. If your DTV receiver does not have a built-in terrestrial tuner, this TV will only be able to provide an analog signal through Ant-A on the TV back panel.
3. Connect the RGB cables from the DTV receiver to the TV back panel as listed below (if your DTV receiver uses BNC-type cables, use the adaptors shown in Figure 11, page 17):

DTV Receiver	TV Back Panel
G (green)	= Y/G
B (blue)	= Pb/B
R (red)	= Pr/R

4. If the DTV receiver has outputs for H and V sync, connect as listed below (**DO NOT** connect if DTV receiver uses "Sync on Green"):

H (horizontal sync)	=	H
V (vertical sync)	=	V

5. Connect the L (left) and R (right) audio cables from the DTV receiver to DTV AUDIO on the TV back panel.
6. To utilize the benefits of a digital A/V receiver, connect your DTV receiver's digital audio out to a digital input on your digital A/V receiver. You may need to setup the DTV (See Input Assignment, page 33) to RGB.

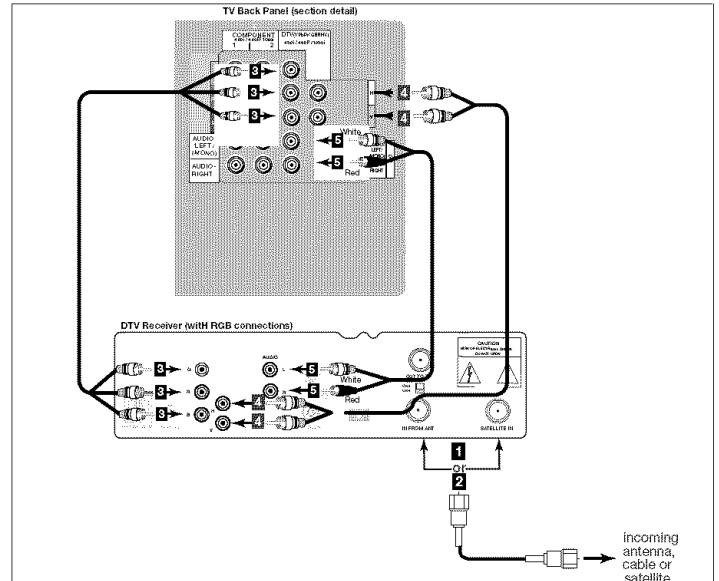

Figure 13. Connecting the DTV receiver with RGB video connections.

IMPORTANT

See Appendix B, page 59, for component video signal compatibility information.

For digital audio connections, see your

Connecting MonitorLink™/DVI

MonitorLink/DVI

(Figure 14)

The Monitor Link/DVI input uses a DVI-I Dual Link connector for maximum cable flexibility. When MonitorLink is used as a DVI-HDCP input, the terminal is compliant with DVI-D Single Link signals matching EIA-861 standards for standard, extended and high definition video with scanning rates of 480p and 1080i. However, this input is not intended for use with personal computers or devices outputting video signals with computer resolutions. All other DTV video signals, such as 720p, need to be converted by the DTV receiver (or compatible device) to one of the compatible signal types. Please check the specifications on your device before connecting.

1. Connect a MonitorLink/DVI cable from the TV back panel to the Mitsubishi HD Receiver/Controller back panel.
2. Connect the L (left) and R (right) audio cables from the HDTV receiver to AUDIO LEFT and AUDIO RIGHT on the MonitorLink section of the TV back panel.

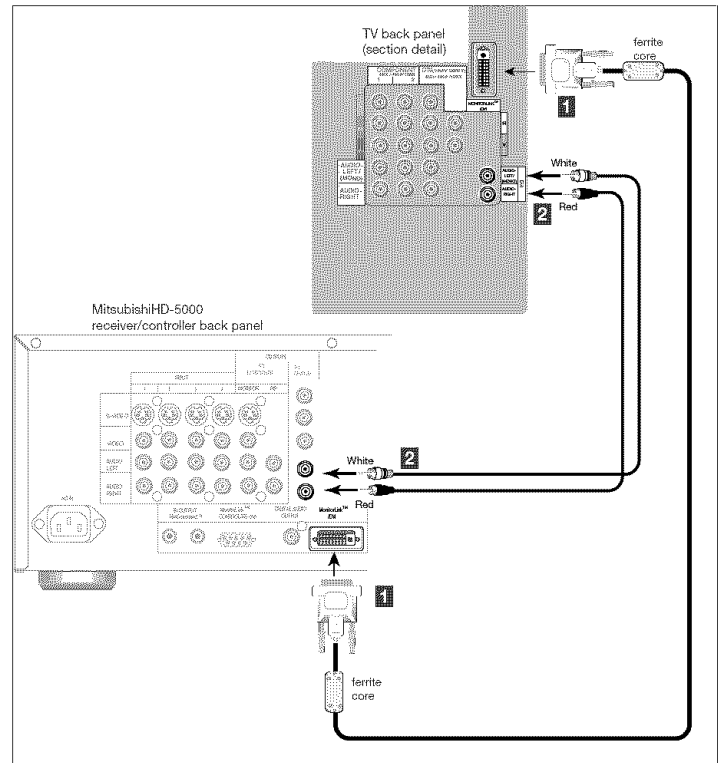

Figure 14. Connecting MonitorLink

IMPORTANT

This connection supports copy protection (HDCP). Some devices require connecting to an analog input first, in order to view on-screen menus and select DVI as the output. Please review your equipment instructions for DVI connectivity and compatibility.

CAUTION: To assure continued FCC compliance, we recommend using a shielded video interface cable with bonded ferrite cores at each end, when using the MonitorLink/DVI input.

How Connections Affect the PIP (Picture-In-Picture) and POP (Picture-Outside-Picture)

To see a picture in the PIP or POP, you may need to select an input source. If the only input connected is ANT-A, then both the main picture and the PIP/POP will be from that input source. If other video equipment is connected, you may be able to view these input sources as the PIP/POP. When connecting your new Mitsubishi TV, it is important to understand which main picture and PIP/POP input sources can and cannot be used together. The table on this page shows which inputs can and cannot be used together and the limitations they may have. If you press the INFO button it will display the current Input, signal (480i, 480p, or 1080i), format, time, day and sleep time.

See Operation of PIP and POP, page 56, for operating instructions.

PIP/POP \ Main	Ant-A	Ant-B	DTV 480i, 480p, 1080i	Input-1 Input-2 Input-3	Components (Comp. -1, -2) 480i, 480p, 1080i
Ant-A	OK*	No PIP/POP	OK	OK	OK
Ant-B	OK	OK*	OK	OK	OK
DTV 480i, 480p, 1080i	OK	OK	OK**	OK	OK
Input-1 Input-2 Input-3	OK	OK	OK	OK**	OK
Components (Comp-1, -2) 480i, 480p, 1080i	OK	OK	OK	OK	OK**
MonLink/DVI	OK	OK	OK	OK	OK

* No Side-by-Side with the same channel

**No Side-by-Side with the same input

Chapter

3

Remote Control Functions

Overview of the TV Layer Buttons	22
Care and Operation	23
Channel Selection.....	24
Sleep Timer	24
Use With Other A/V Products.....	25
Special Functions	27
Operation of PIP and POP.....	28

Remote Control Functions: Overview of the TV Layer Buttons

Overview

(Figure 1, following page.)

1. **Slide Switch:** Select A/V product to be controlled by the remote control.
2. **Numbers:** Individually select channels or input information into TV.
3. **POWER:** Turns power on and off for TV and other connected A/V products.
4. **SQV (SuperQuickView™):** Scan through a memorized list of favorite channels.
5. **QV (QuickView™):** Switch to last channel viewed.
6. **SLEEP:** Set the TV to turn off within 2 hours. See Sleep Timer, page 24, for setup instructions.
7. **INPUT:** Select the signal to view; Ant-A, Ant-B, DTV, Component-1, Component-2, Input-1, Input-2, Input-3 or MonLink.
8. **CHANNEL:** Scroll up or down through memorized channels. Skips DVD chapters in DVD layer.
9. **VOLUME:** Change sound level.
10. **VIDEO:** Select the individual video settings.
11. **AUDIO:** Select the individual audio settings.
12. **MUTE:** Turn sound on or off.
13. **ENTER/EXCH:** Select a channel number or menu item. Exchange PIP or POP with the main TV picture.
14. **ADJUST:** Navigate menus, change settings, and move the PIP on-screen location.
15. **HOME:** Exit on-screen menus and return to TV viewing.
16. **CANCEL:** Clear SQV and some menu entries. Used as a subchannel button in Cable/DBS/DTV layer.
17. **MENU:** Display  on-screen menu system.
18. **V-CHIP:** Displays V-Chip Passcode screen, use to enable or disable the V-Chip Lock.
19. **PIP INPUT:** Select the PIP or POP input source.
20. **PIP CH:** Scroll up or down through memorized channels in PIP or POP.
21. **INFO:** Displays on-screen summary of the current input used and any broadcast information available (including current V-Chip information, signal source, scan rate and format). Additionally, if you press the INFO key, it will display time, day and sleep time.
22. **FORMAT:** Change the shape and size of the main TV picture.
23. **PIP/POP:** Cycle through PIP and POP display choices.
24. **GUIDE:** When the slide switch is set to CABLE/DBS/DTV, displays the on-screen program guide (some cable boxes and DBS/DTV receivers).
25. **REC:** Manually record with your VCR or recordable DVD.
26. **STOP:** Stop your VCR, DVD, or CD.
27. **PAUSE:** Pause your VCR, DVD or freeze the PIP or POP image.
28. **REW/REV:** Rewind or reverse search with your VCR, reverse scan with your DVD, or skip reverse with your CD.
29. **PLAY:** Play your VCR, DVD, or CD.
30. **FF/FWD:** Fast forward or forward search with your VCR, fast play with your DVD, or skip forward with your CD.
31. **LIGHT:** Illuminates buttons or labels on the remote control. Located on the left side of the remote.

Remote Control Functions: Care and Operation

Operation

Installing the Batteries:
(Figure 2)

1. To remove the back battery cover, gently press the ridged tab in the direction of the arrow and slide the cover off.
2. Load the batteries, making sure the polarities (+) and (-) are correct. For ease of installation, install the negative (-) side first.

For Best Results from the Remote Control:

- Be within 20 feet of the equipment.
- Do not press two or more buttons at the same time unless instructed to.
- Do not allow to get wet or become heated.
- Avoid dropping on hard surfaces.
- Do not use harsh chemicals to clean. Use only a soft, lightly moistened cloth.
- Do not mix new and old batteries.
- Do not heat, take apart, or throw batteries into fire.
- Use only AAA batteries.

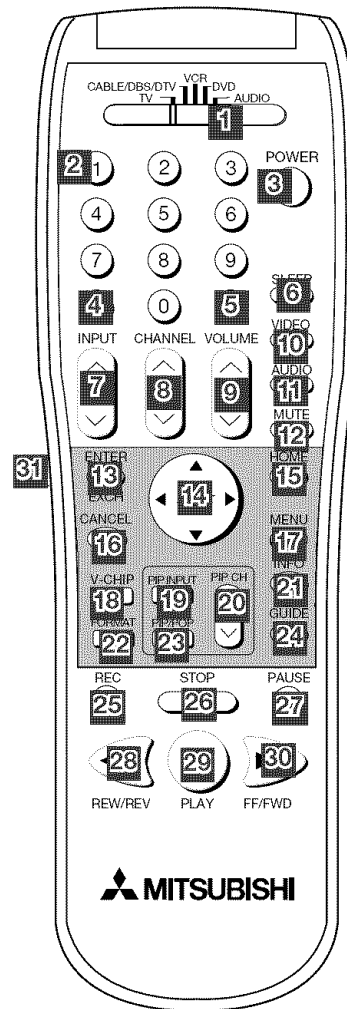

Figure 1. Remote Control Functions.

Operating the Remote Control:

You can use the remote to control the TV, CABLE/DBS/DTV, VCR, DVD, and AUDIO products. Select the product you want to control by moving the slide switch to the appropriate position. The remote control has been preset to operate the TV and other Mitsubishi products. To program the remote control to operate other products, see Use of the Remote Control with Other A/V Products, page 25.

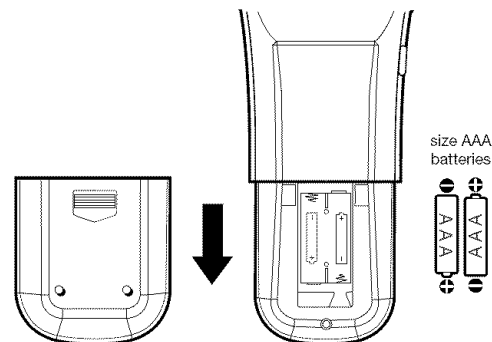

Figure 2. Installing the batteries.

IMPORTANT

The remote control may return to its initial setting when the batteries are changed. It may need to be reprogrammed.

Remote Control Functions: Channel Selection, Sleep Timer



Figure 3. Sleep button on remote control

Channel Selection

- Enter three numbers (for channel 2, press 002).
- or
- Press the channel number and ENTER (for channel 2, press 2, then ENTER).
- or
- Enter the channel number and wait four seconds (without pressing ENTER). The TV will change automatically.

Note: Use the CANCEL button for digital subchannel (-) selection in the CABLE/DBS/DTV layer.

Sleep Timer

(Figure 3 & 4)

Setting the Sleep Timer:

- Press SLEEP on the remote control.
- A message indicating the length of time the sleep timer is to be set appears on the TV screen.
- Each press of SLEEP will increase the time displayed by 30 minutes, until the maximum value of 120 minutes is reached.
- After 5 seconds of inactivity, the message will disappear.
- Press SLEEP to view the remaining time before the timer turns the TV off.

Canceling the Sleep Timer:

- Press the SLEEP button to display the on-screen message.
- Press SLEEP repeatedly until OFF is displayed. After 5 seconds of inactivity, the message will disappear.

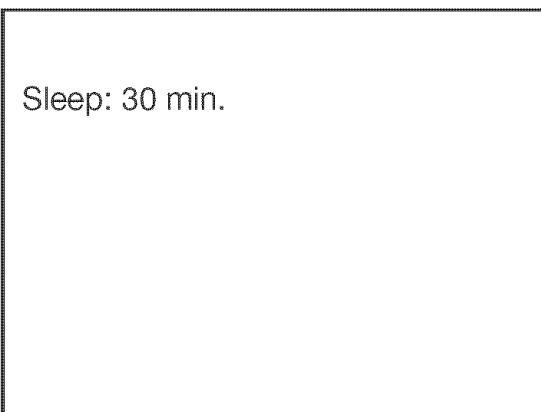

Figure 4. On-screen display for sleep timer

Use of the Remote Control with Other A/V Products



Programming the Remote Control to Use with Other Brands of Audio and Video Products:

(Figures 1-4 this page, Figure 5, following page)

1. Move the slide switch at the top of the remote to the product you want to control.
2. Press and hold the POWER button on the remote control.
3. Enter the first three digit code listed for your equipment, and then release the POWER button on the remote control.
4. Point the remote control to the equipment and press the POWER button.

Note: If the equipment responds, the remote control is properly programmed to operate the equipment. If the equipment does not respond, repeat steps 2-4 with the next three digit code listed in step 3.

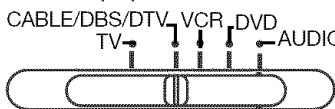

1.  2. 



3. **Cable Box Codes**

Cable box brand	Code to enter:	If your cable box code is not listed here, please see page 60 for a complete listing.
General Instruments/ Jerrold	119, 120, 121, 122, 123, 124	
Motorola	125, 126, 127	
Oak	139, 137, 102	
Pioneer	101, 116	
Scientific Atlanta	112, 113	
Zenith	117, 100	

To reset to default code, enter 000

Figure 1. Programming the remote to control your cable box.

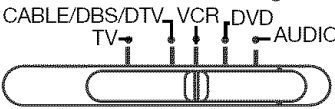

1.  2. 

3. **VCR Codes**

VCR brand	Code to enter:	If your VCR code is not listed here, please see page 61 for a complete listing.
Mitsubishi	001, 002	
Hitachi	020, 043, 065	
JVC	030, 054	
Phillips / Magnavox	043, 044, 051	
Panasonic	041, 042, 043	
RCA	020, 053, 065	
Sony	048, 049, 050	
Toshiba	021	

To reset to default code, enter 000

Figure 3. Programming the remote to control your VCR.



IMPORTANT

If you cannot turn the cable box ON by pressing POWER, try pressing CHANNEL or the number buttons.

IMPORTANT

When set to TV, the PLAY, STOP, REW/REV, and FF/FWD buttons will operate the VCR after the VCR codes have been properly programmed into the remote control.

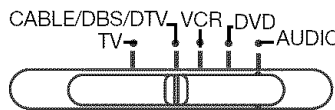

1.  2. 



3. **Satellite Receiver Codes**

Satellite brand	Code to enter:	If your satellite receiver code is not listed here, please see page 61 for a complete listing.
Mitsubishi DTV - DBS	006	
DishNetwork	175	
Hughes - DBS	173	
Panasonic - DBS	174	
RCA - DBS	176	
Sony - DBS	177	
Toshiba-DBS	170, 173, 189, 190, 191	

To reset to default code, enter 000

Figure 2. Programming the remote to control your satellite receiver.

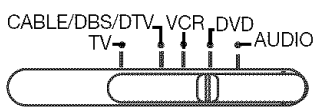

1.  2. 

3. **DVD Player Codes**

DVD/LDP brand	Code to enter:	If your DVD code is not listed here, please see page 60 for a complete listing.
Mitsubishi	003	
JVC	257	
Panasonic	250	
Phillips	258, 253, 272	
Pioneer DVD	252	
Samsung	261	
Sony	254	
Toshiba	253	

To reset to default code, enter 000

Figure 4. Programming the remote to control your DVD or LDP.

Use of the Remote Control with Other A/V Products, continued

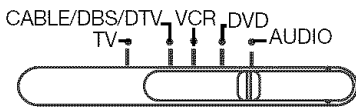
1. 

2. 

3.

A/V Receiver Codes	
Audio brand	Code to enter:
Mitsubishi A/V receiver and/or CD player	010, 015, 011, 012, 013, 014
Denon	234, 235, 236, 245, 246, 359
Harman Kardon	215, 223, 242
JVC	233, 232
Kenwood	208, 200
Marantz	224, 350
Onkyo	209, 214, 240, 247
Pioneer	205, 207
Sony	222, 249
Technics	218, 219, 221
Yamaha	202, 201, 243, 244
To reset to default code, enter 000	

If your audio code is not listed here, please see page 60 for a complete listing.

Figure 5. Programming the remote to control your A/V receiver.

IMPORTANT

If the slide switch is set to TV when you enter an A/V receiver code, VOLUME and MUTE will control the A/V receiver rather than the TV. To return volume and mute control to the TV, set the slide switch to TV, press and hold POWER and enter 000.

IMPORTANT

Some manufacturers may change their products, or they may use more than one remote control system. If this is the case, your remote control may not be able to operate your VCR, DVD, cable box, satellite receiver, or A/V receiver.

After entering the correct codes in each position of the remote control, use the slide switch to select which product will respond when an operational button is pressed. If you enter a code from the A/V Receiver Codes chart while the slide switch is set to TV, the volume and mute functions change to match the A/V receiver. This is useful when using an A/V receiver with the TV all the time. In all other cases, only one of the below devices is allowed for each slide switch position.

TV position:

- TV
- A/V receiver (volume and mute only)

Cable/DBS/DTV position:

- Cable box
- Satellite receiver
- DTV receiver

VCR position:

- VCR

DVD position:

- DVD
- LD Player

Audio position:

- A/V receiver
- Mitsubishi CD player

If you have a Mitsubishi A/V receiver, the audio position may be used in conjunction with select Mitsubishi CD players. Your audio position must be programmed to either 010 or 011. Plug the CD player power cord into a switched outlet on the back of your A/V receiver. Pressing the POWER button turns On the A/V receiver, along with the CD player. In the audio position, for some CD players, the transport controls (FF, Play, Rew, etc.) operate the CD player.

Remote Control Functions: Special Functions

When your remote control has been programmed to operate another manufacturer's product, the function performed on each layer may vary. The most common functions are:

VCR <ul style="list-style-type: none">• POWER• CHANNEL up/down• PLAY• REC• PAUSE• STOP• FF/FWD• REW/REV Mitsubishi VCRs will be compatible with some additional buttons
Cable Boxes and Satellite Receivers <ul style="list-style-type: none">• POWER• CHANNEL up/down• 0-9 number buttons (on some models)• ENTER (on some models)• CANCEL (on some models)• ADJUST up/down/ left/right (on some models)• GUIDE (on some models)
A/V Receivers <ul style="list-style-type: none">• POWER• VOLUME• MUTE
Mitsubishi A/V Receivers <ul style="list-style-type: none">• Direct Input Selection buttons: numbers, SQV and QV (on some models)
Mitsubishi CD Players (not all functions for all models) <ul style="list-style-type: none">• PLAY• FF/FWD• REW/REV• PAUSE• STOP
DVD and Laser Disc Players (not all functions for all models) <ul style="list-style-type: none">• POWER• MENU• 0-9 number buttons (on some models)• PLAY• STOP• ARROW up/down/left/right (on some models)• FF/FWD• REW/REV• PAUSE• CANCEL (on some models)• ENTER• CHANNEL (on some models)

Remote Control Operation of PIP and POP

Picture-In-Picture (PIP) and Picture-Outside- Picture (POP) features allow you to view programming in different ways. While watching the main screen, you can display programs from other channels and other inputs. To see which inputs can and cannot be used together, see *How Connections Affect the PIP and POP*, page 20. You can display large and small PIPs, side-by-side pictures, three POPs, or nine POPs.

Activating the PIP and POP

Press PIP/POP to choose a display format. Each time the PIP/POP button is pressed on the TV remote control (within 3 seconds of each other), the PIP/POP cycles through the following display options.

1. **POP:** side-by-side pictures
2. **POP:** three POPs
3. **POP:** nine POPs
4. **PIP:** large PIP
5. **PIP:** small PIP

To turn PIP/POP **Off**, wait at least 10 seconds, and press PIP/POP. The next time you activate PIP/POP, the last used PIP/POP format will be displayed first. See page 56 for more PIP and POP information.

Chapter

4

Menu Screen Operations

The ViewPoint® Menu System	30
MAIN Menu	31
SETUP Menu.....	33
CAPTIONS Menu	37
CHANNEL EDIT Menu.....	39
V-CHIP LOCK Menu.....	42
ADVANCED FEATURES Menu.....	46
AUDIO/VIDEO SETTINGS Menu	50

The ▶ViewPoint® Menu System

Mitsubishi's exclusive ▶ViewPoint® on-screen operating system provides on-screen information for menu choices and changes.



A picture (icon) will be highlighted and can be selected using the remote control's ADJUST arrows.

When selected, the appropriate menu will appear or start an automatic function. You may then make changes within the menu or access available sub-menus.



A highlighted square button indicates that you may make changes to the menu screen.

The ▶ViewPoint® system includes the following special features:

- The currently selected icon or button is highlighted with a rectangular yellow outline and the text color will be yellow.
- On-screen instructions provide complete menu choice information.
- Some on-screen menu options must be set before other options are available. For example, "Timer Menu" will only be possible if "Clock Time" and "Set Day" have been set.

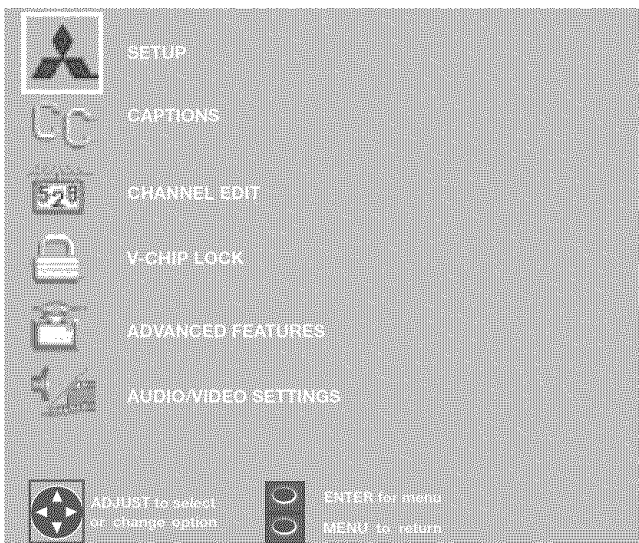

Figure 1. MAIN menu: The first screen to appear when you press MENU button on the remote.

The following remote control buttons allow you to move quickly through the ▶ViewPoint® system (Figure 2):

ADJUST ▲ or ▼ to select the menu item you want to change.

ADJUST ▶ to move to the setting field.

ADJUST ▲ or ▼ to change the settings.

ADJUST ◀ to move back to the menu item.

ENTER to enter into a menu, start an automatic function, or select a checkbox.

CANCEL to clear a setting, or stop an automatic function.

MENU to move back one menu screen at a time.

HOME to exit all menus at once and return to TV viewing.

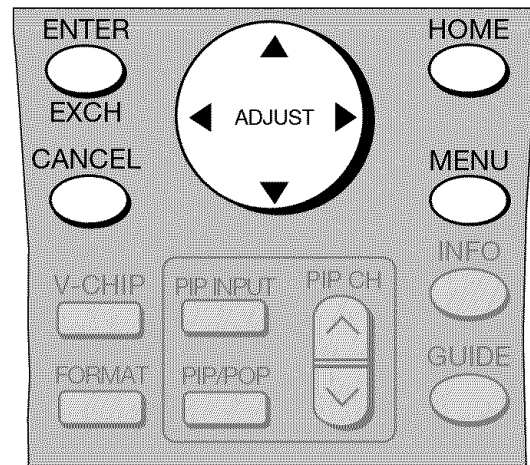

Figure 2. Remote control buttons used for navigation within the ▶ViewPoint® on-screen operating system.

Main Menu Screens: Overview

SETUP Menu

(Figure 3)

Basic (initial) setup instructions and functions are available through the SETUP submenu screens. Use this menu when you relocate the TV, experience a power loss or when devices are added after initial setup.

- Memorize channels
- Assign Input Assignments
- Set the time and day
- Select English or Spanish for the menus or screen display
- Set the Energy Mode

See pages 33-36 for detailed setup information.

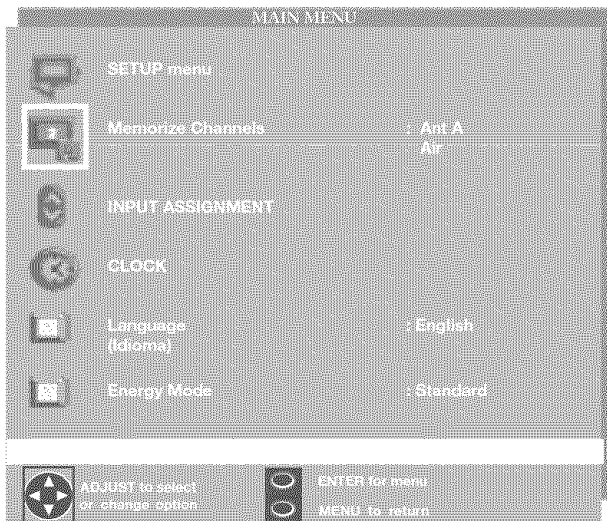

Figure 3. SETUP menu

CAPTIONS Menu

(Figure 4)

Display broadcast captions or text on the screen. Select the settings by choosing to display the background color as either black or translucent gray. See pages 37-38 for detailed setup information.

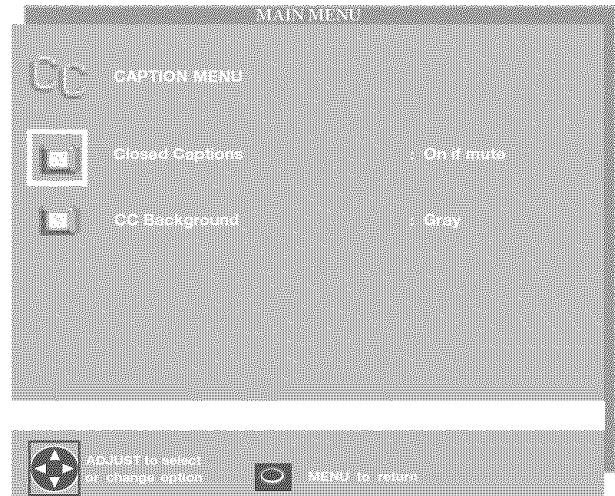

Figure 4. CAPTIONS menu

CHANNEL EDIT Menu

(Figure 5)

- Customize channel information for Ant-A &Ant-B
- Manually add or delete channels from memory
- Name channels for Ant-A and Ant-B
- Add your favorite channels to a SQV (Super Quick View™) list.

See pages 39-41 for detailed setup information.

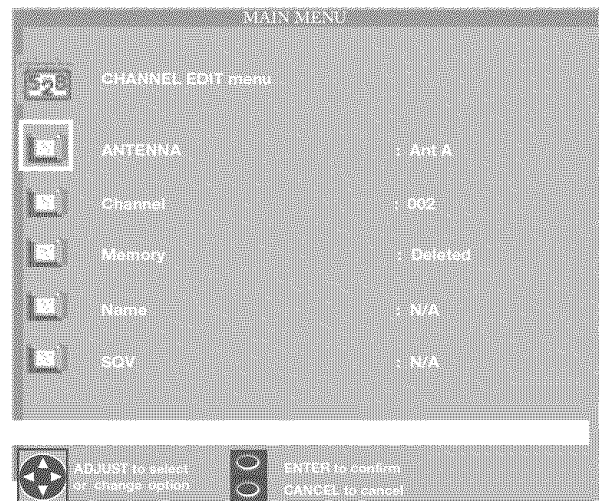

Figure 4. CHANNEL EDIT menu

Main Menu Screens: Overview, continued

V-CHIP LOCK Menu

(Figure 6)

Lock the TV by selecting times, setting the Front Button Lock or choosing programs to block based on rating signals sent by your local broadcasting system.

See pages 42-45 for detailed setup information.

See page 42 for V-Chip rating information.

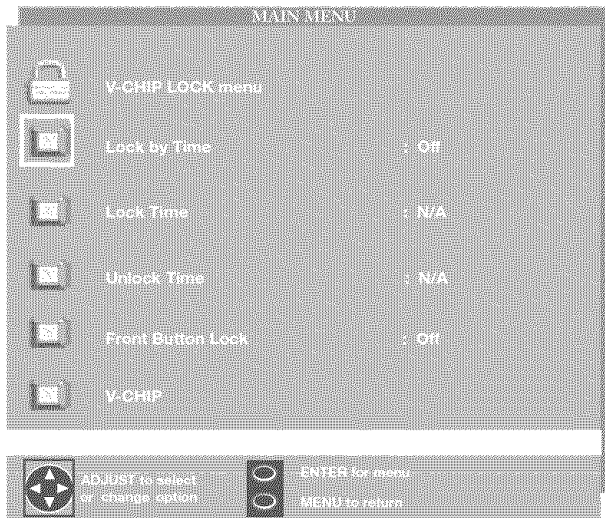

Figure 6. V Chip Lock Menu

AUDIO/VIDEO SETTINGS Menu

(Figure 8)

Adjust some or all of the A/V settings. Each input can be set to your preferences. A/V Reset on the menu allows you to return the A/V settings for the current input to the factory presets. A/V Reset on the front control panel resets all inputs at one time.

See pages 50-52 for detailed setup information.



Figure 8. Audio/Video Settings Menu

ADVANCED FEATURES Menu

(Figure 7)

Adjust colors automatically or manually, using Color Balance. Set your TV to turn on automatically. Display a blue screen when viewing an input with no signal. Enhance the darker parts of bright pictures.

See pages 46-49 for detailed setup information.

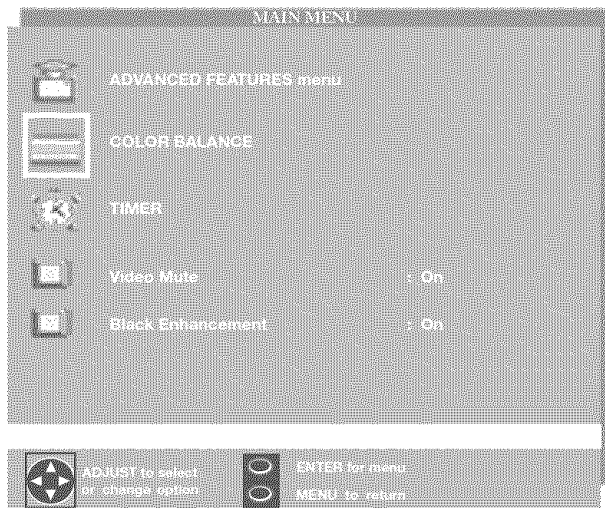

Figure 7. ADVANCED FEATURES Menu

SETUP Menu: Memorize Channels, Memorize Menu, Input Assignment

Memorize Channels

(Figure 9)

Select Memorize Channels for each antenna you use. The TV will find and remember strong channels and skip the unused or weaker channels.

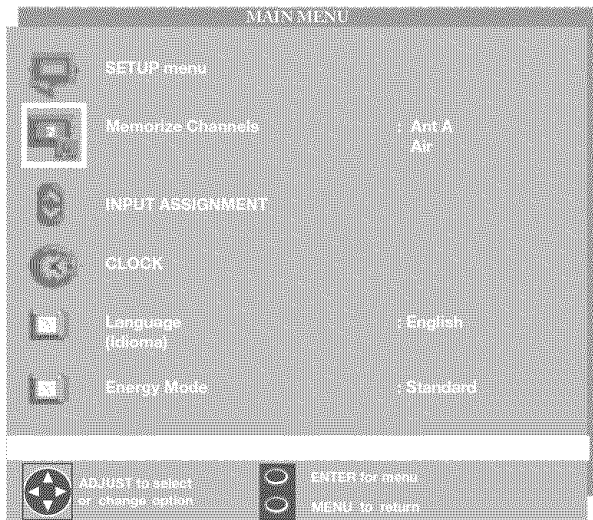

Figure 9. Memorize Channels Menu

MEMORIZE Menu

(Figure 10)

Stop memorization at any time by pressing CANCEL. Channels memorized prior to pressing CANCEL will stay in memory. After channels are memorized, you may select memorized channels in ascending or descending order by pressing the CHANNEL button on the remote control.

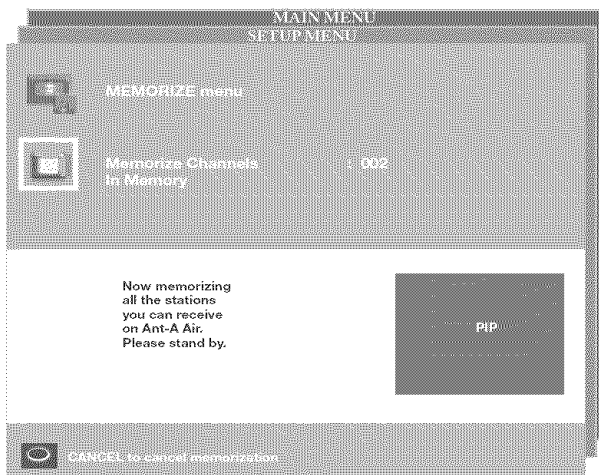

Figure 10. Memorize Menu

INPUT ASSIGNMENT Menu

(Figure 11)

INPUT ASSIGNMENT turns off unused inputs, turns them on again or changes the name of the input. If you turn an input Off, it will be skipped when you press INPUT on the remote control. Choices are:

- ANT-A, ANT-B: On or Off
- DTV: Y/Pb/Pr, RGB, RGBHV or Off
- COMPONENTS
Cycle through a list of preset names or Off
- INPUT-1, INPUT-2, INPUT-3:
Cycle through a list of preset names or Off
- MonitorLink (MONLINK)
Cycle through a list of preset names or Off

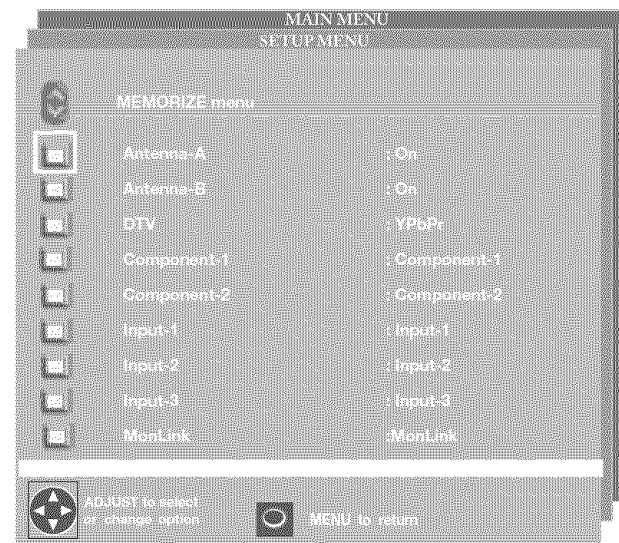

Figure 11. Input Assignment Menu

IMPORTANT

DTV Note: If you have a DTV receiver connected, you will need to use that receiver's channel memorization system to memorize digital channels.

SETUP Menu: Manually Setting the Clock

Clock Setting (Manual)

(Figure 12)

The Clock Setting menu default allows the clock time to be set manually. To set the clock automatically, please see page 35.

To set the clock manually, first select the current time, including AM or PM.

Press ▲ or ▼ to slowly adjust the time. Press and hold ▲ or ▼ to quickly adjust the time.



Figure 12. Clock Time

Set Day

(Figure 13)

After manually selecting the current time, select the current day.



Figure 13. Set Day

SETUP Menu: Automatically Setting the Clock

Clock Setting (Auto)

(Figure 14)

Set the Clock Setting to Auto to automatically set the day and time using Extended Data Service (XDS) time data. This data is automatically retrieved when tuned to a PBS channel or other channel in your area that provides this service.



Figure 14. Clock Setting (Auto)

Time Zone

(Figure 15)

Select the correct time zone (Atlantic, Eastern, Central, Mountain, Pacific, Alaska, or Hawaii) for your area when Auto has been selected as the Clock Setting.



Figure 15. Time Zone

Daylight Savings Time

(Figure 16)

Select the Daylight Savings Time (DST) option that your state uses when Auto has been selected for the Clock Setting.

Applies = uses DST

Ignore = does not use DST

The clock time and day will be set automatically after tuning to a channel carrying the Extended Data Service (XDS) time data (usually your local PBS channel).



Figure 16. Daylight Savings Time

SETUP Menu: Language, Energy Mode

Language

(Figure 17)

Display the on-screen menus in either English or Spanish (Español). The first time you powered On your TV, you were requested to select an on-screen menu language. If you choose to change the selection, all menu text will immediately switch to the language of your choice.

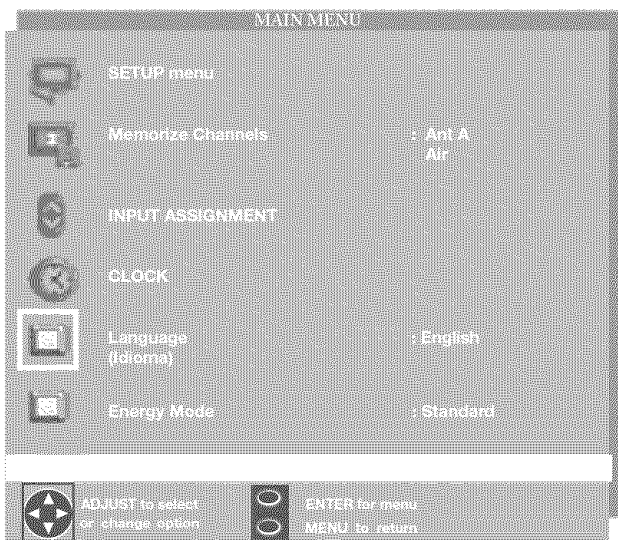

Figure 17. Language/Idioma

Energy Mode

(Figure 19)

Change the setting to Low (less than 1 watt) and the TV will operate in an energy saving mode when it is turned off.

If the Energy Mode is set to Low, it will not be possible to record while the TV's power is off. There will be no signal from LOOP OUT (on the TV back panel) to the VCR and/or cable box.

Note: The Standard setting has a faster turn on time, but uses more power than the Low setting. Standard is recommended.

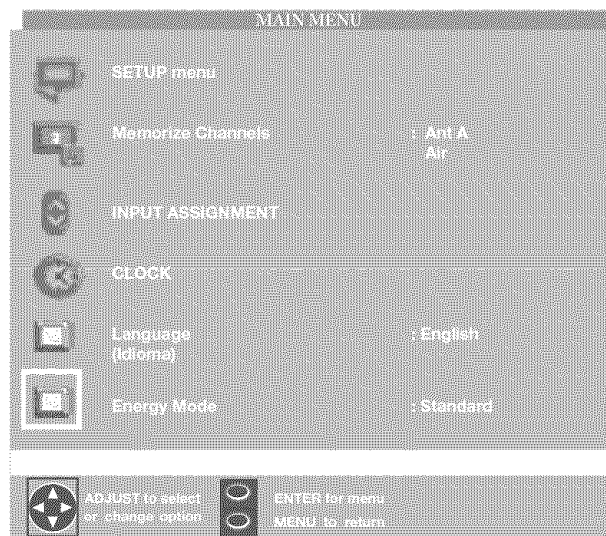

Figure 19. Energy Mode

CAPTIONS Menu: Overview

CAPTIONS Menu

(Figure 20)

Turn On or Off the closed caption decoder, select the type of captions or text, and choose black or translucent gray as the background color for the closed caption area.

Broadcasters can send either Standard or Text closed captioning.

Standard closed captioning follows the dialogue of the characters on-screen and displays in a small section of the screen.

Text closed captioning often contains information such as weather or news and covers a large portion of the on-screen program. Your TV can decode four different standard and four different text closed captioning signals from each TV station. However, each TV station may broadcast only one or two closed captioning signals, or none at all.

IMPORTANT

When Text closed captioning is selected, a large black or gray box will appear on your TV screen if no signal is broadcast.

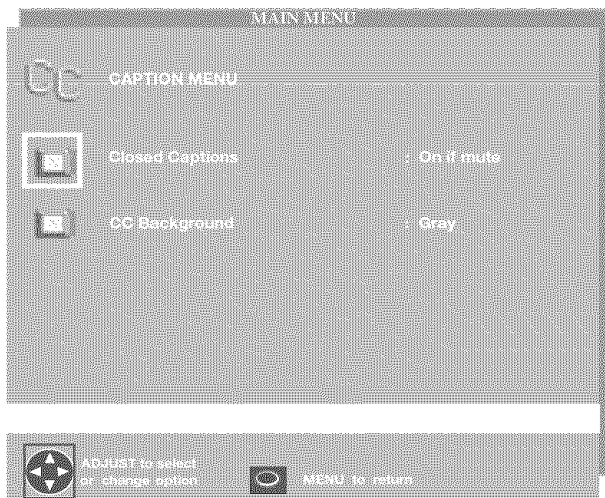





Figure 20. CAPTIONS menu

CAPTIONS Menu: Closed Captions, Background Color

Closed Captions

(Figure 21)

Display one of the following types of Closed Captions:

-  CC1, CC2, CC3, or CC4: Standard closed captioning signals.
-  Text1, Text2, Text3, or Text4: Text closed captioning signals.
-  On if mute: Closed captions when mute. When selected, the standard closed captioning signal (CC1) will turn on/off by pressing the MUTE button on the TV remote control.
-  Off: No closed captions.

CC Background

(Figure 22)

Display the background color as either black or translucent gray, to make the closed captions easier to read.



Figure 22. CAPTIONS menu

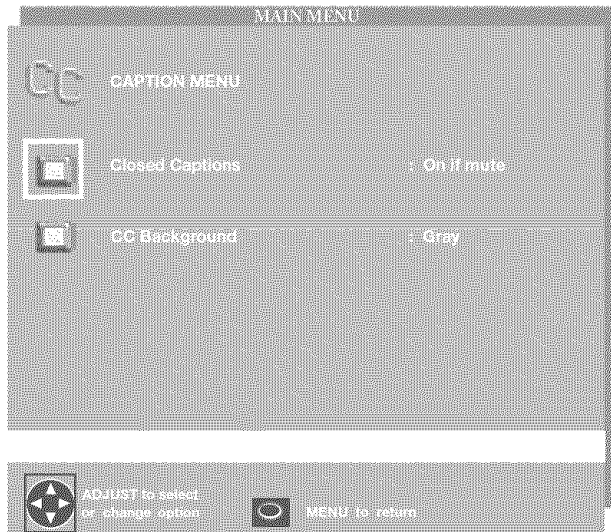

Figure 21. Closed Captions

IMPORTANT

The content of captions is determined by the broadcaster. If your captions show strange characters, misspellings, or odd grammar, it is not a malfunction of the TV.

CHANNEL EDIT Menu: Antenna, Channel Selection

Antenna

(Figure 23)

Select Ant-A or Ant-B. For each antenna, you can add or delete channels in memory, name channels, and add channels to the SQV (SuperQuickView™) list.

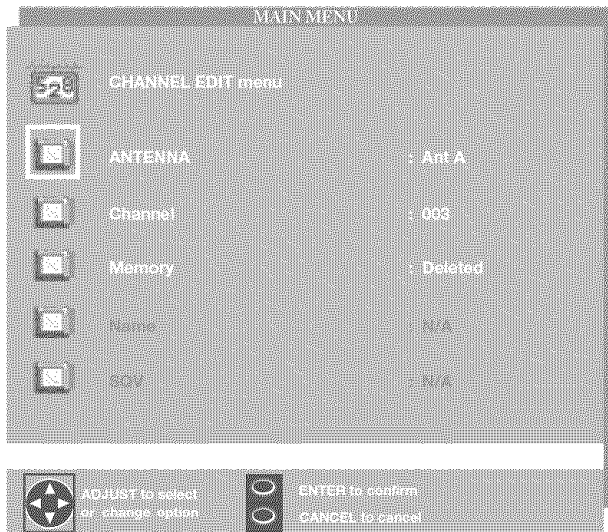

Figure 23. Antenna

Channel

(Figure 24)

Select to edit the channel selections. You can add or delete from memory, name, or add to the SQV (SuperQuickView™) list.

After selecting Channel, editing can be done using the Adjust buttons or entering the 3 digit channel number you want to change (for channel 2, 002).

You can also select channels by using the CHANNEL button on the remote control.

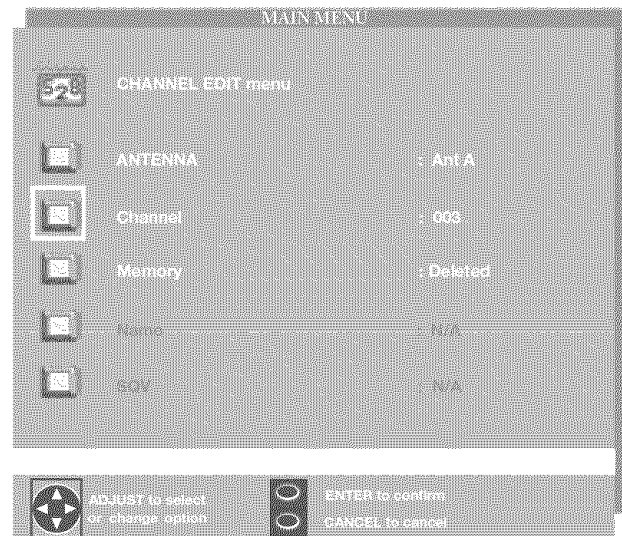

Figure 24. Channel

CHANNEL EDIT Menu: Memory, Name Selection

Memory

(Figure 25)

Add weaker channels viewed with Ant-A or Ant-B and delete unwanted channels, after all available channels have been memorized with Memorize Channels (page 33). Use the CHANNEL button on the remote control to view memorized channels.

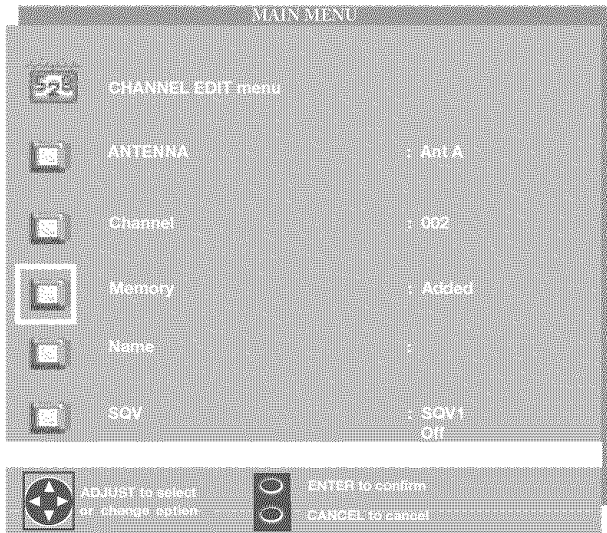

Figure 25. Memory

Name

(Figure 26)

Name channels shown on Ant-A or Ant-B (up to four characters). After you enter a name, it will appear on the TV screen next to the channel number.

1. Select Ant-A or Ant-B.
2. Select the memorized channel you want to name.
3. Press ADJUST until you see the underline highlighted in the Name field.
4. Use ADJUST ▲ or ▼ to select letters A-Z, numbers 0-9, and/or symbols (!.&'/*- and blank) for each character of the name you would like for the selected channel. Press ENTER after choosing each letter and after the name is complete. If you want to change your selection while on the option field, use CANCEL to delete the current character. You will move one position back. If you press CANCEL while at the first character, the entire name will be deleted.

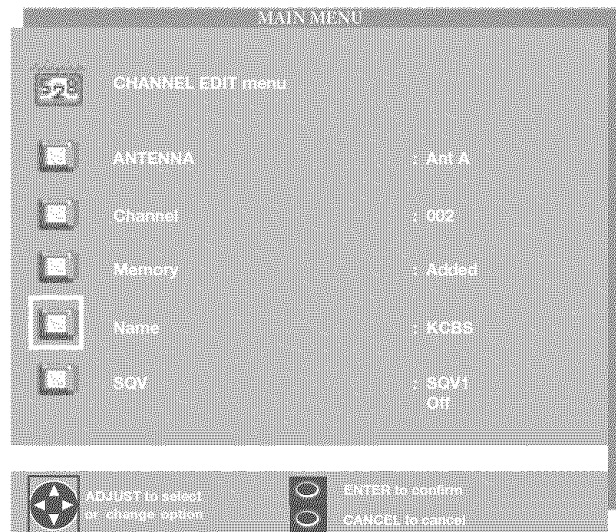

Figure 26. Name

CHANNEL EDIT Menu: Using SQV (Super Quick View™)

SQV Using The Menu Screen

(Figure 27)

Put together a list of your favorite channels from Ant-A and Ant-B using SQV (SuperQuickView™). Store up to 6 channels in each of the 9 different memory banks. After adding a channel to the SQV memory, “SQV” will appear under the channel number on the TV screen.

To change SQV choices using the menu:

1. Press ▲ or ▼ when at Channel settings or use the CHANNEL button on the remote control to select the channel you wish to add or delete from a SQV memory bank.
2. Press ► when at SQV in the menu to move the selector to the On/Off setting.
3. Press ▲ or ▼ when at SQV setting to select the SQV memory bank you wish to modify.
4. Press ENTER to add (On) or delete (Off) the current channel from the SQV memory bank that you have selected.

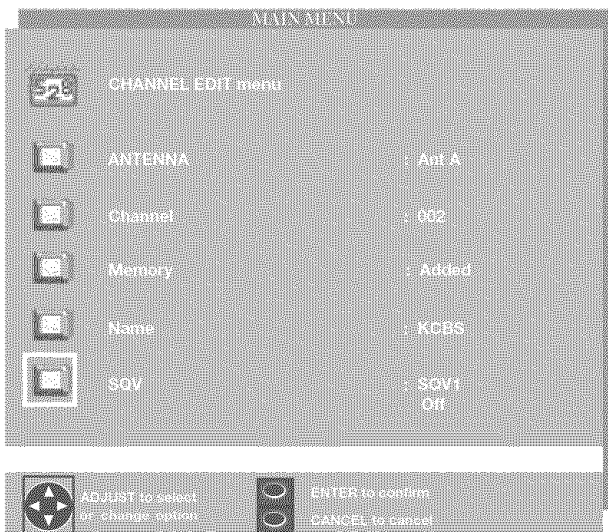

Figure 27. SQV (Super Quick View™)

SQV Using The Remote Control

(Figure 28)

View and add SQV channels using the remote control:

1. Use the CHANNEL or number buttons to select the channel you want to add.
2. Press and hold the SQV button for about 3 seconds. When “SQV” and the memory bank number appear under the channel number, the channel has successfully been added.

To change the SQV banks using the remote control:

1. Press the SQV button.
2. To change memory banks, press a number button within 5 seconds of pressing the SQV button.

Remove SQV channels using the remote control:

1. Press the SQV button repeatedly until you see the desired channel.
2. While the channel number and SQV indicator are still displayed on the screen, press CANCEL. If CANCEL is not pressed before the SQV indicator disappears, the channel will not be removed. When the SQV indicator disappears, the channel has successfully been removed.

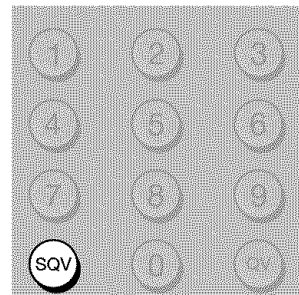

Figure 28. SQV button on the remote control

V-Chip Lock Menu: Overview

V-Chip Signal Information

When provided by the broadcaster, V-Chip ratings can be used to control which programs can be viewed or will be blocked. When V-Chip ratings are sent, you will see the ratings when you change the channel or when you press the INFO button on the remote control. Both TV and Movie ratings will display. TV ratings apply to programs and movies developed for TV and may have supplemental blocking by content categories. Movie ratings use MPAA ratings for movies released in theaters.

V-CHIP EXCEPTIONS:

1. V-Chip is effective only for programs viewed on Ant-A, Ant-B, or from devices connected to Inputs 1-3. It is not effective for programs viewed on devices connected to Component Input or MonitorLink™.
2. Videotapes, laser discs and DVDs may not contain V-Chip rating signals. If they don't contain the V-Chip signal, V-Chip cannot block the program or movie.
3. Broadcasters are not currently required to include V-Chip rating signals at this time. If the broadcaster does not include the V-Chip rating signal, V-Chip cannot block the program.

TV Ratings:

Used with TV programs and Made-for-TV movies.

TV-Y Youth, for children under the age of 7.

TV-Y7 Youth, 7 years old and older. For children 7 years old and older.

TV-G General Audience. For the entire family to view.

TV-PG Parental Guidance. Parental Guidance is recommended, may not be suitable for some children.

TV-14 Adolescent 14 years old and older. Not recommended for children under the age of 14.

TV-MA Mature Audience. For adults only.

TV Rating	FV	D	L	S	V
TV-Y					
TV-Y7	X				
TV-PG		X	X	X	X
TV-14		X	X	X	X
TV-MA			X	X	X

Content Categories:

Used in association with the TV ratings above.

FV Fantasy Violence- applies to TV-Y7 only.

D Sexual Dialog- applies in different degrees to TV-PG and TV-14.

L Adult Language-applies in different degrees to TV-PG, TV-14, and TV-MA.

S Sexual Situations- applies in different degrees to TV-PG, TV-14, and TV-MA.

V Violence (graphic or realistic)- applies in different degrees to TV-PG, TV-14, and TV-MA.

When you select a TV rating, you are selecting the least-restricted program level that can be viewed. As an example, if you select TV-PG, you are allowing programs rated TV-Y, TV-Y7, TV-G and TV-PG to be seen and blocking programs rated TV-14 and TV-MA. When you select a TV Content category, you will block all TV programs that have the same content category listing. As an example, if you select to block V (Violence) at the TV-14 level, you will also block any program that has the V category listing at the TV-PG rating level as well.

Movie Ratings:

Used with theater released movies and direct-to-video movies.

G General Audience- Designed for the entire family to view.

PG Parental Guidance- Parental Guidance is recommended, may not be suitable for some children.

PG-13 Parental Guidance 13 years old and older- Not recommended for children under the age of 13.

R Restricted- Restricted in the theater to 17 years old and older unless accompanied by an adult.

NC-17 No Children- Restricted in the theater to 18 years old and older.

X Adult- Designed for and restricted in the theater to adult audiences only.

When you select a Movie rating, you are selecting the least restricted program level that can be viewed. As an example, if you select a movie rating of PG-13, you are allowing movies rated G, PG and PG-13 to be seen and blocking movies rated R, NC-17, and X.

Programs Not Rated: Used for programs that are not rated like news, sports, weather, emergency bulletins, or movies such as those prior to or without MPAA Ratings. This does not include programs without V-Chip signals.

IMPORTANT

If you select to block programs that carry the V-Chip rating "Programs Not Rated", you may block News or Emergency Bulletins, when "None" or "NR" (Not Rated) V-Chip rating is included. Care should be used when blocking programming that is not rated.

V-CHIP Menu: Setting Up and Using V-Chip Lock Passcode

Setting Up the V-CHIP LOCK Passcode

(Figure 29)

Select V-CHIP LOCK from the MAIN menu for first time setup or after you have canceled your passcode. You will see the screen shown in Figure 29. Use the number buttons on the remote control to input a new four-digit passcode, then press ENTER.

Before pressing ENTER, you can delete a character and move back one character by pressing CANCEL, or leave the passcode screen by pressing MENU or HOME.

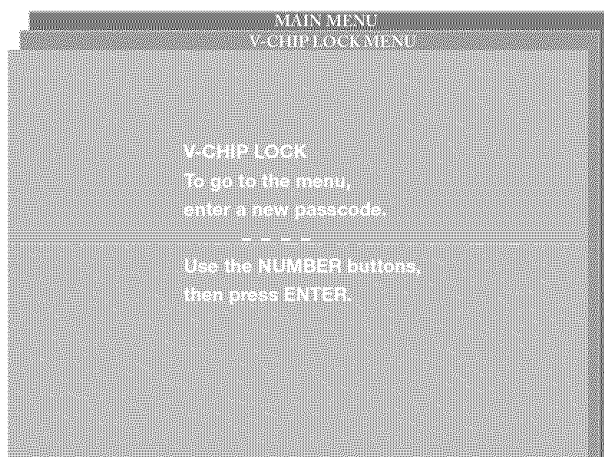

Figure 29. First time entry to the V-CHIP LOCK

Entering the Passcode

(Figure 30)

Input your passcode as shown in Figure 30 (Note: Text changes from “a new” to “your” passcode). The next time you select V-CHIP LOCK from the MAIN menu, you will see this screen.

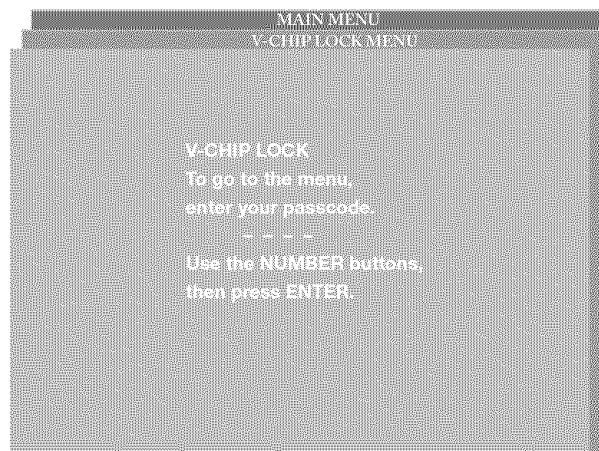

Figure 30. Re-entry to the V-CHIP LOCK

IMPORTANT

If you forget your four-digit passcode, see Appendix A, page 57.

V-CHIP Menu: Locking by Time, Front Button Lock, V-Chip Rating Menu

LOCK by Time

(Figure 33)

Select On at Lock by Time, then select the Lock Time and Unlock Time. This will lock the entire TV. Your TV continues to be locked until you input your passcode, or when the locked time expires.

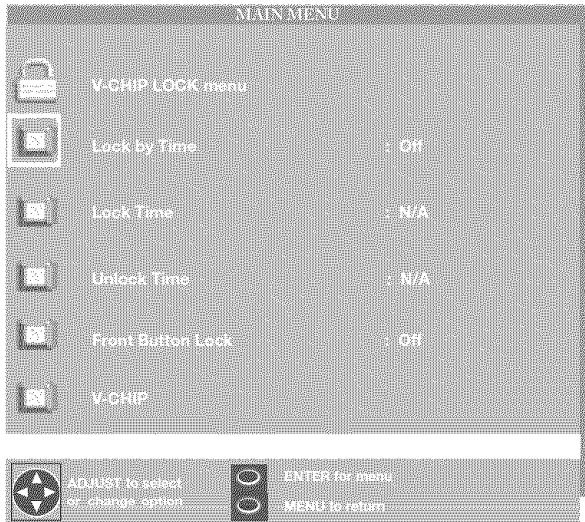

Figure 33. V-CHIP LOCK Menu Lock by Time

Front Button Lock

(Figure 34)

Setting the Front Button Lock to On will disable controls on the front panel to prevent anyone from accidentally changing settings. Off will restore the operations of the front panel buttons.

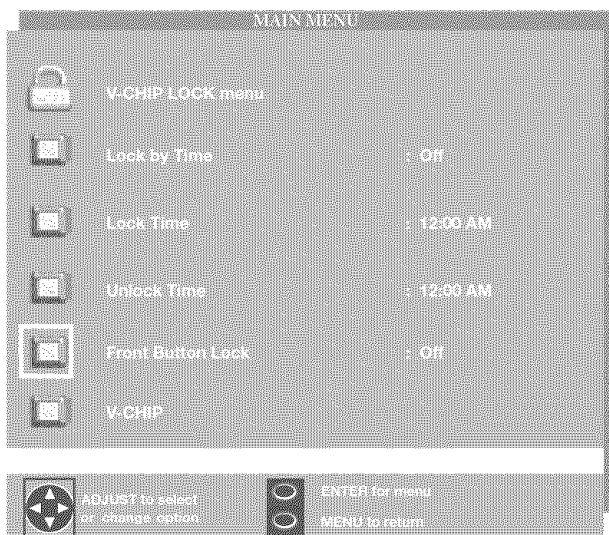

Figure 34. Front Button Lock

If the front panel buttons have been locked and you misplace the remote control, you can restore the function of the front panel buttons by pressing and holding the MENU button on the front panel for more than 8 seconds. If the TV is already on, a message will be displayed to confirm the release of the Front Button Lock.

Selecting V-Chip Rating Menu

(Figure 35)

To block or allow programs based on the rating system described on page 42, select V-Chip to go to the V-Chip Rating menu.

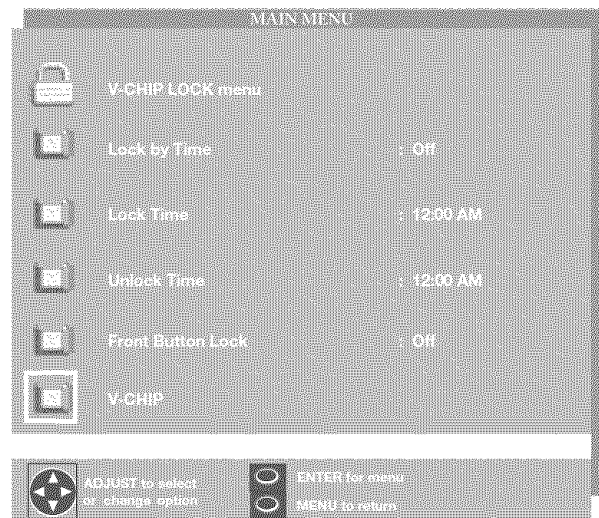

Figure 35. Selecting V-Chip Rating Menu

V-CHIP Menu: Allowing or Blocking Ratings, Lock by Time

Allowing or Blocking by Ratings

(Figure 36)

Block or Allow programs based upon rating signals sent by the broadcasting station. The factory preset for TV Ratings is TV-PG (Parental Guidance) allowing only programs rated TV-PG or lower. The factory preset for Movies is PG, allowing only movies rated PG or lower. Please refer to page 42 for a detailed ratings description.

V-CHIP HOURS

V-CHIP HOURS will allow you to activate the V-Chip or lock the entire TV during specific hours.

To set V-Chip Hours, select V-Chip Hours from the V-CHIP LOCK menu.

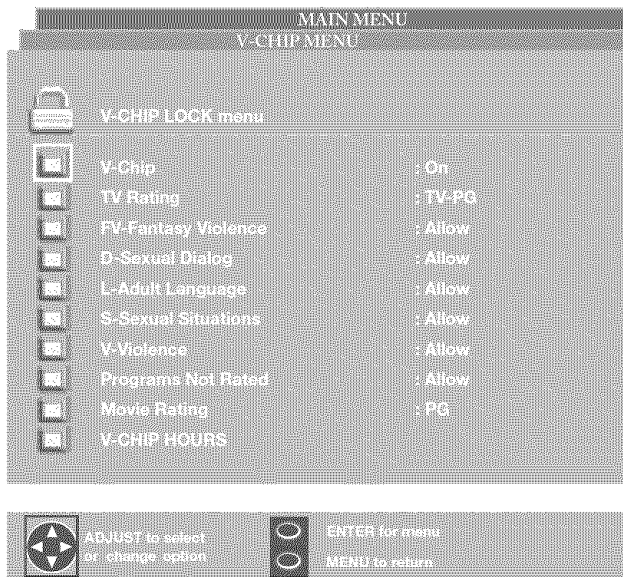

Figure 36. Ratings Menu

V-CHIP Start Time and V-CHIP Stop Time

(Figure 37)

Select the times you would like the V-Chip to be Active. By setting the V-Chip Start Time and V-Chip Stop Time to the same time, the V-Chip will be active 24 hours a day.

Press ▲ or ▼ to slowly adjust the time. Press and hold ▲ or ▼ to quickly adjust the time.

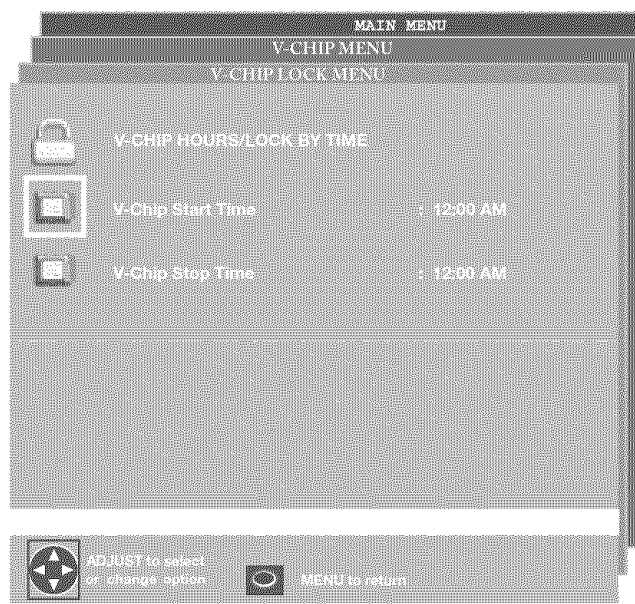

Figure 37. V-CHIP HOURS, LOCK BY TIME

ADVANCED FEATURES Menu: Color Balance, Auto Color Correction, PerfectColor™, Reset Color

Color Balance Menu

(Figure 38)

The Color Balance Menu uses six colors (Magenta, Red, Yellow, Green, Cyan and Blue). You may adjust the intensity of these colors automatically or manually or reset them to the default settings.

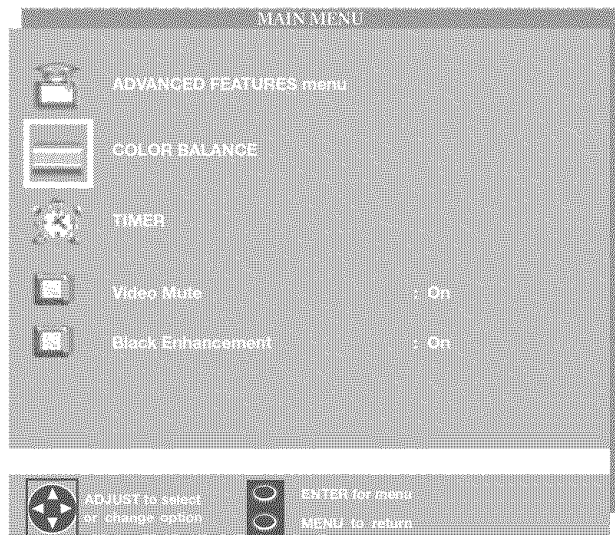

Figure 38. COLOR BALANCE

Auto Color Correction

(Figure 39)

Auto Color Correction optimizes skin tone color automatically and continuously. Manual Color Adjustment and Reset Color options are grayed out and unavailable when On is selected.

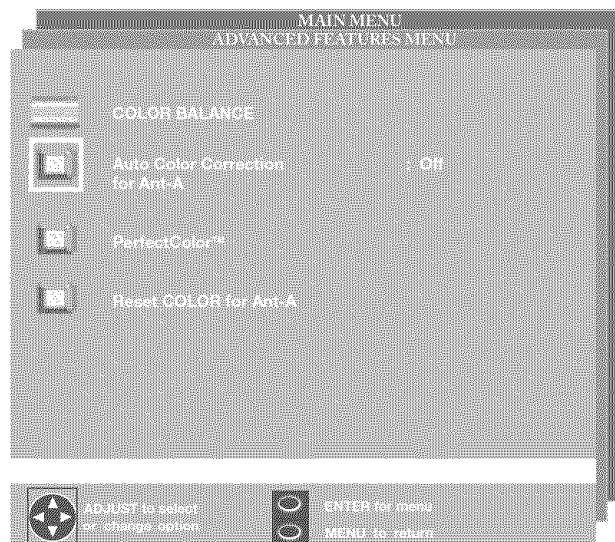

Figure 39. Auto Color Correction

PerfectColor

(Figure 40)

Certain TV channels may appear more green or red than others. This is not a malfunction of the TV and may vary by channel or broadcaster. The PerfectColor menu allows you to adjust color settings based on your preferences.

PerfectColor is only available when Auto Color Correction is turned Off. Press ENTER to display the menu for manual color adjustment. Individual color sliders will be displayed and each active input can be individually adjusted. They have a numeric value, where 63 is the maximum. The default setting for each color is 31 (center). Highlighted text will show which slider you are adjusting. Press Adjust ▲ or ▼ to navigate between colors and Adjust ◀ or ▶ to change the color slider settings.

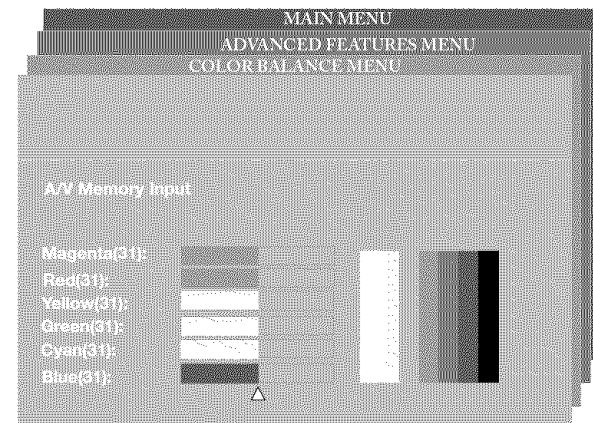

Figure 40. PerfectColor Menu

Reset Color

(Figure 39)

Select to reset the PerfectColor settings. Each active input can be individually reset.

ADVANCED FEATURES Menu: TIMER, Timer Menu, and Set Time

TIMER

(Figure 41)

The timer will automatically turn the TV on (if it is off) at the time you schedule and select. When Ant-A or Ant-B is the selected input, you may select any memorized channel. The TV will tune to this channel when the timer turns it on.

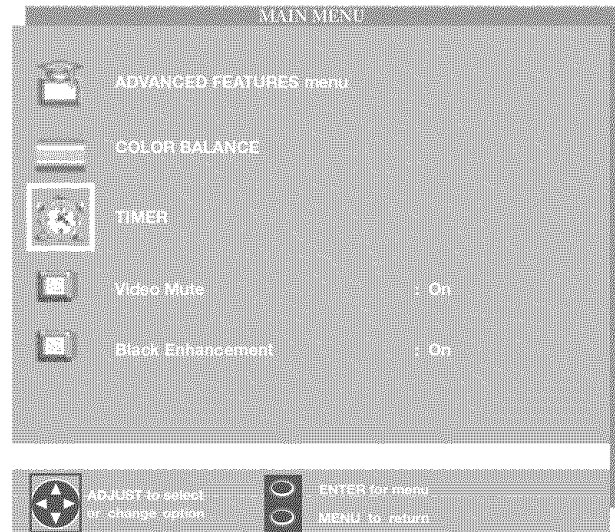

Figure 41. ADVANCED FEATURES (menu Timer)

TIMER menu

(Figure 42)

The timer can be turned On or Off. When On, you need to select the time and the day to turn On and the input and channel to display. At your preselected time, the timer will turn the TV on and a message will be displayed, "Press a key for the TV to stay on." Any button on the remote control must be pressed within 5 minutes or the TV will turn itself off.

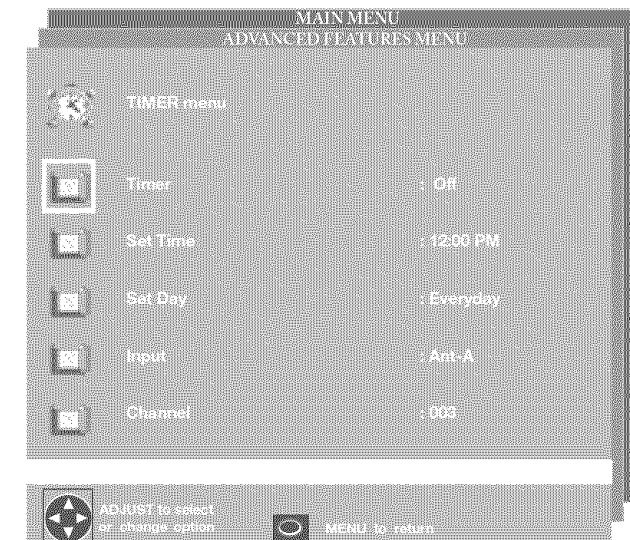

Figure 42. TIMER menu (Timer)

Set Time

(Figure 43)

Select the hour and minute, including AM or PM, when the TV is to turn on.

Press ▲ or ▼ to slowly adjust the time. Press and hold ▲ or ▼ to quickly adjust the time.



Figure 43. TIMER menu (Set Time)

IMPORTANT

You must set the TV clock before you can set the timer. If you have not set the clock and/or day, you will see the CLOCK menu instead of the Timer menu.

ADVANCED FEATURES Menu: Set Day, Input, and Channel

Set Day

(Figure 44)

Select the days that the TV will turn on automatically. You can select Everyday, Mon-Fri (Monday through Friday), or the individual days of the week.

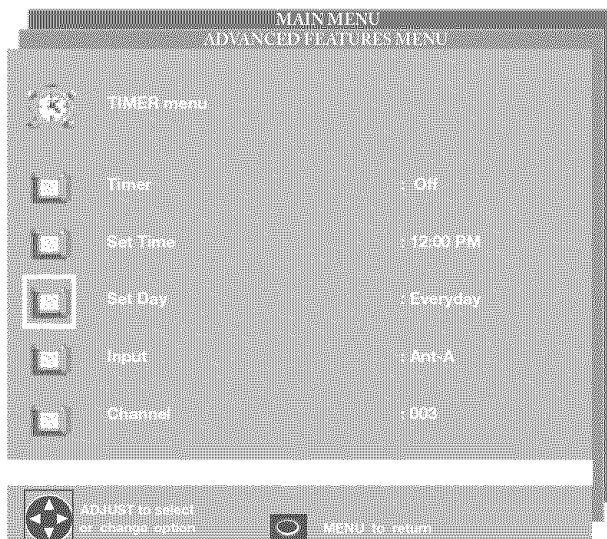

Figure 44. TIMER menu (Set Day)

Channel

(Figure 46)

If the selected input is for Ant-A or Ant-B, the timer will turn the TV to the selected channel.

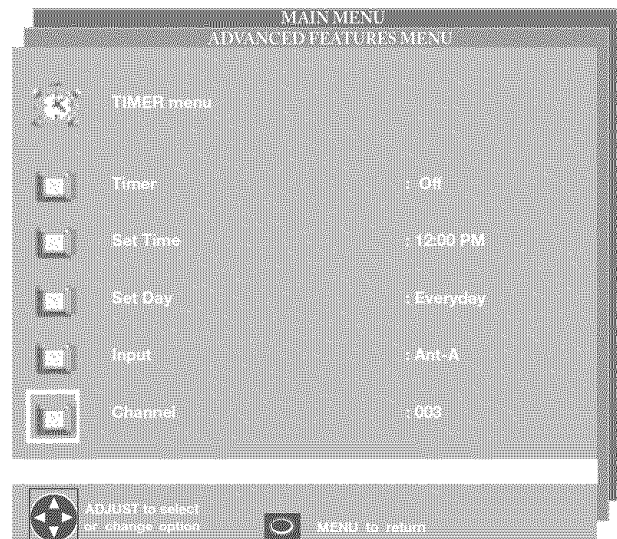

Figure 46. TIMER menu (Channel)

Input

(Figure 45)

Select the input to use when the timer turns on the TV. If the TV is already on, the timer will turn the TV to this selected input.

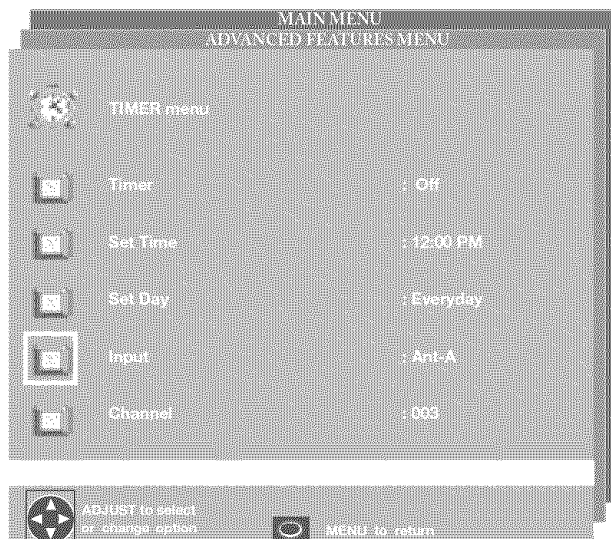

Figure 45. TIMER menu (Input)

ADVANCED FEATURES Menu: Video Mute, Black Enhancement

Video Mute

(Figure 51)

Video Mute, (when On) lets you display a blue background when no signal is being received on Inputs 1-3, DTV, Component 1-2 and MonLink.

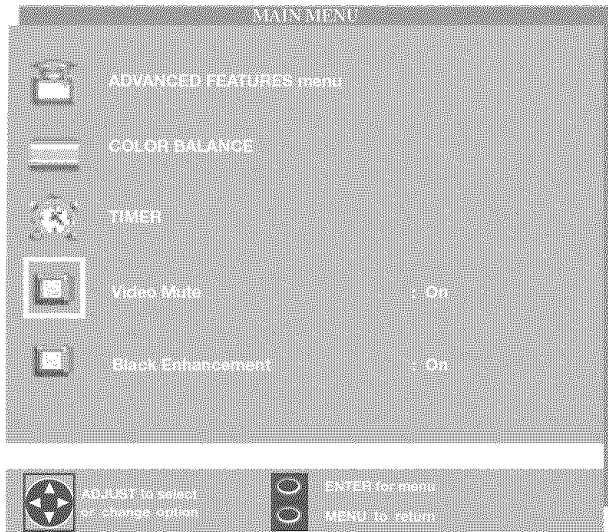

Figure 51. Video Mute

Black Enhancement

(Figure 52)

The contrast in dark scenes is enhanced for better picture quality. Brighter scenes will not be affected.

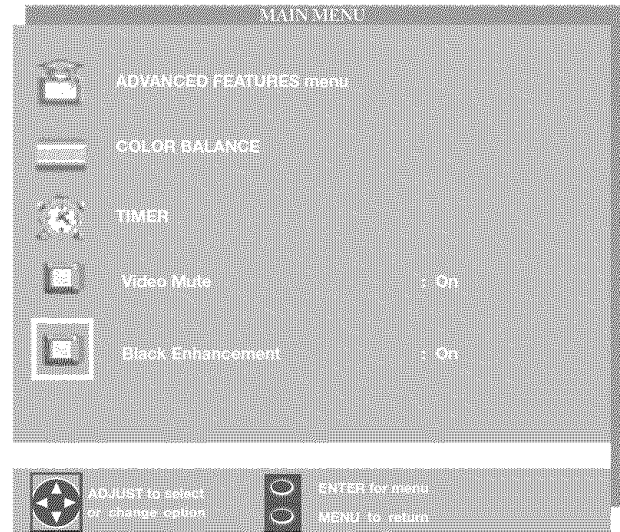

Figure 52. Black Enhancement

AUDIO/VIDEO SETTINGS Menu: Overview

AUDIO/VIDEO SETTINGS Menu

(Figure 53)

Each input has its own A/V memory. You can adjust each input's A/V memory in two ways. You can use the menu or the remote control.

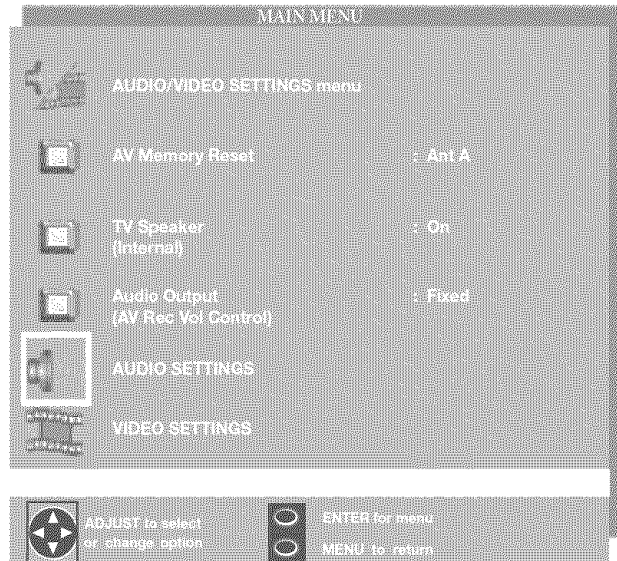

Figure 53. AUDIO/VIDEO SETTINGS menu

A/V Memory Reset

A/V Memory Reset will return the currently selected input's A/V memory to the factory settings. To reset an input's A/V memory, select A/V Memory Reset, select the input you want to reset, and press ENTER.

TV Speakers

This selection will turn on or off the TV's internal speakers. You may select Off when sending the sound through a separate stereo system or surround sound A/V receiver.

Audio Output

Select Fixed if your audio receiver or stereo system can be controlled with a remote. This allows you to adjust the volume with the system's remote control or the TV remote control, if compatible. This setting is better for surround sound receivers. Select Variable if your audio receiver or stereo system cannot be controlled with a remote. This allows the TV's internal circuitry to adjust the volume.

AUDIO SETTINGS and VIDEO SETTINGS

After selecting AUDIO SETTINGS or VIDEO SETTINGS, you can adjust the settings by pressing ▲, ▼, ◀, or ▶. For descriptions of the individual A/V settings, see AUDIO/VIDEO Setting Descriptions, pages 51-52.

Using the AUDIO and VIDEO Buttons on the Remote Control

1. Press AUDIO or VIDEO to cycle through the available settings.
2. Press ◀ or ▶ to adjust the setting. After 5 seconds of inactivity, the setting display will disappear.

AUDIO/VIDEO Setting Descriptions: Audio

Audio Settings

- **Bass**
Enhances or reduces low frequency sound.
- **Treble**
Enhances or reduces high frequency sound.
- **Balance**
Adjusts the level of sound between the left and right speakers.
- **Surround**
Creates simulated stereo and surround effects. Your choices are:

Off: No surround effects. Use this setting when using an A/V receiver with Dolby™ Pro Logic Surround, or Dolby™ Digital Surround.

Simulated Stereo: Your TV will create a simulated stereo effect when watching a non-stereo program.

Surround Sound: Your TV will create a simulated surround effect when watching a stereo program.

Listen to (for Ant-A and Ant-B): Determines how your TV will receive a broadcast audio signal and play back the sound you hear. Your choices are:

Stereo: Default setting. The TV will play stereo broadcasts in stereo and mono broadcasts in mono. The word “Stereo” will be displayed when you tune to a channel broadcasting stereo.

SAP (Second Audio Program): Additional monaural soundtrack that you cannot hear during normal TV viewing. The SAP signal might be related to the program you are watching, such as a soundtrack in a foreign language, or unrelated to the program you are watching such as a weather report. If a SAP signal is broadcast, the letters “SAP” will be displayed when you tune to the channel.

Mono: Reduces background noise and should be used when receiving a weak stereo audio signal. All audio will be played mono with this setting.

- **Listen to (for INPUTs)** Is not available.
- **Level Sound**
Automatically equalizes the volume level of programs containing significant level differences from one segment to another (for example, regular programming to commercials). To receive the best fidelity with music programs, you can turn this setting to Off.

Note: A slider will display on-screen for each setting. The slider has a numeric value, where 63 is the maximum, the mid-range is 31 and the minimum setting is 0.

AUDIO/VIDEO Setting Descriptions: Video

Video Settings

A compressed (non-HD) video signal may cause what appears to be a “blurry”, “out of focus” or “fuzzy” picture on a widescreen TV. This is not a malfunction of the TV, but a result of the compressed signal that is sent by cable or satellite. To re-adjust the picture, try the following:

Adjust your video settings (specifically sharpness) for optimal picture performance.

Change the format size (pages 54-55).

- **Contrast**
Provides a slider to adjust the white-to-black level. Low contrast shows a variety of shades in darker images, while high contrast shows darker images more uniformly black and makes colors appear more vibrant.
- **Brightness**
Provides a slider to adjust the overall brightness of the picture.
- **Sharpness**
Provides a slider to adjust the detail and clarity.
- **Color**
Provides a slider to adjust the color intensity.
- **Tint**
Provides a slider to adjust the proportion of red to green.
- **Color Temp (Color Temperature)**
Allows you to adjust how images are displayed. Your choices are:

Low: Images will have a warm cast to them. This adjustment is an average and can vary due to ambient room lighting, video scene brightness and the TV’s age.

Medium: Images will be balanced between the Low (warm) and High (cool) settings.

High: Images will have a cool cast to them. This setting may provide the most realistic picture under bright lighting.

- **Video Noise**
Reduces minor noise (graininess) in the broadcast or input signal. This function operates only in 480i mode.
- **Film Mode (Automatic)**
Video media uses a video camera created at 30 frames per second. Film media uses a film camera created at 24 frames per second. Examples of video media are live TV broadcast such as news, special events, or video taped programs. Examples of film media are motion pictures, made-for-TV movies, and many prime time programs. Filmed media is converted by the broadcaster or home video company to 30 frames per second to match TV or video standards. This conversion can leave subtle “picture artifacts” or conversion errors.

The settings are On and Off. If you select On, the system automatically detects if the signal source is Film and corrects for conversion errors. If you select Off, the system will never correct for conversion errors. This function operates only in 480i mode.

Note: A slider will display on-screen for each setting. The slider has a numeric value, where 63 is the maximum, the mid-range is 31 and the minimum setting is 0.

Note: For optimal picture performance, it is recommended that you adjust your video settings (specifically contrast and brightness) during initial setup. Certain factors will affect your personal preferences, including room lighting, glare reflections and viewing angles/distance.

1. The first part of the document discusses the importance of maintaining accurate records of all transactions and activities. It emphasizes that this is crucial for ensuring transparency and accountability in the organization's operations.

2. The second part of the document outlines the various methods and tools used to collect and analyze data. It highlights the need for consistent and reliable data collection processes to ensure the validity of the results.

3. The third part of the document describes the different types of data that are collected and analyzed. It includes information on both quantitative and qualitative data, as well as the specific variables being measured.

4. The fourth part of the document discusses the various statistical techniques used to analyze the data. It covers topics such as descriptive statistics, inferential statistics, and regression analysis.

5. The fifth part of the document presents the results of the data analysis. It includes a detailed description of the findings, including any trends, patterns, and relationships that were identified.

6. The sixth part of the document discusses the implications of the findings and provides recommendations for future research and practice. It emphasizes the need for ongoing monitoring and evaluation to ensure that the organization remains effective and efficient.

7. The seventh part of the document provides a summary of the key findings and conclusions. It highlights the most important results and the overall message of the study.

8. The eighth part of the document includes a list of references and a list of appendices. The references provide information on the sources of the data and the methods used in the study. The appendices provide additional information on the data collection and analysis processes.

9. The ninth part of the document includes a list of figures and tables. These provide visual representations of the data and the results of the analysis.

10. The tenth part of the document includes a list of footnotes and a list of abbreviations. These provide additional information on the study and the data.

Available On-Screen Format Sizes

Note: You can find aspect ratios on the back of most DVD covers. Also, Anamorphic DVDs are usually marked “Anamorphic” or “Enhanced for 16:9 TVs.”

Format (picture shape) availability based on Input/Signal

INPUTS	Standard	Expand 480i/480p	HD Expand 1080i	Zoom	Stretch Plus Stretch	Narrow
Ant-A 000	YES	YES	NO	YES	YES	YES
Ant-B 000	YES	YES	NO	YES	YES	YES
DTV (480i/480p)	YES	YES	NO	YES	YES	YES
DTV (1080i)	YES	NO	YES	NO	NO	NO
Input-1	YES	YES	NO	YES	YES	YES
Input-2	YES	YES	NO	YES	YES	YES
Input-3	YES	YES	NO	YES	YES	YES
Component-1 or 2 (480i/480p)	YES	YES	NO	YES	YES	YES
Component-1 or 2 (1080i)	YES	NO	YES	NO	NO	NO
DVI (480i/480p)	YES	YES	NO	YES	YES	YES
DVI (1080i)	YES	NO	YES	NO	NO	NO

Stretch*

Default format for Ant-A and Ant-B, and Inputs 1-3. The Stretched format stretches narrow 4:3 images across the screen, however, there is less stretch in the center than the sides.

Stretch Plus*

Similar to stretch mode, however to minimize distortions on the side, the picture is expanded to crop off portions of the top and bottom. Useful when no important information is shown at the top and/or bottom of the screen.

Narrow*

Displays narrow 4:3 images in their original shape and adds stationary gray side bars to fill the screen. The gray bars are considered a fixed image. .

Standard

Default format for DTV and Component Input displays a full-screen format. The Standard format displays Anamorphic DVDs that have the 1.78:1 or 1.85:1 aspect ratios. However, Anamorphic DVDs that have the 2.35:1 aspect ratio still display black bars at the top and bottom of the screen, while narrow (4:3) images are stretched evenly from side to side.

HD Expand (1080i)**

Enlarges the picture, cropping some of the image on both sides. This Expand format removes or reduce black side bars on HD broadcasts of 4:3 images with black bars.

Expand (480i/480p)*

Enlarges the picture, cropping some of the image at the top and bottom. The Expand format reduces the letterbox top and bottom bars of non-Anamorphic DVDs or to correct narrow 4:3 images that have been stretched in the Standard format.

Zoom*

Enlarges the picture, cropping some of the image at each side, top and bottom. The Zoom format removes or reduce the black top and bottom bars on Anamorphic DVDs with 2.35:1 aspect ratio.

* These formats are not available in the 1080i signal.

** HD Expand is only available in the 1080i signal.

Available On-Screen Format Sizes, continued

Widescreen Picture (16:9 - HD 1080i only) Example: A True HD Broadcast

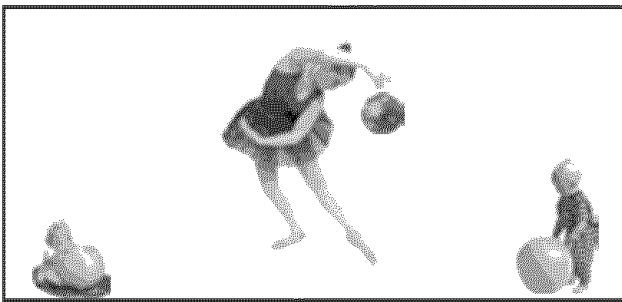

Standard (Recommended)

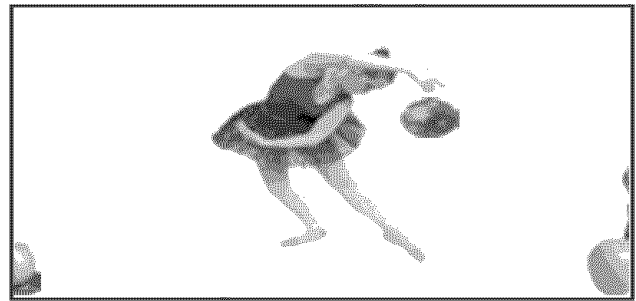

HD Expand (Recommended for 4:3 images with Black Side Bars)

Widescreen Picture (480i/480p)

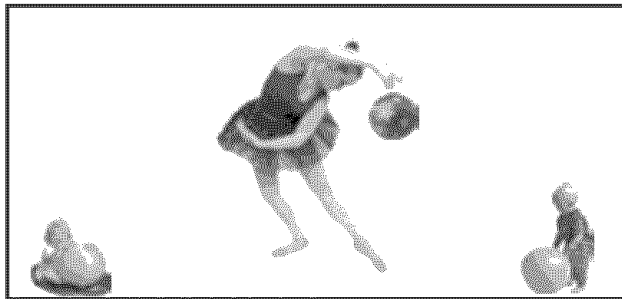

Standard (Recommended)



Expand



Zoom (For letterbox 2.35:1 DVDs)

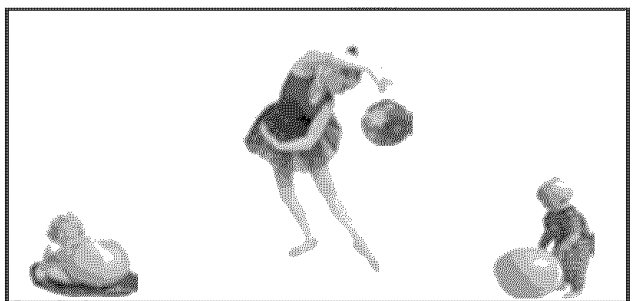

Stretch



Stretch Plus

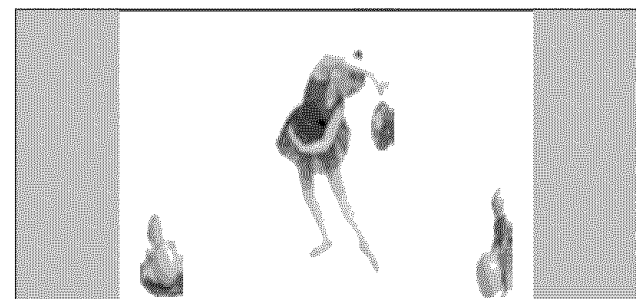

Narrow (Not Recommended)

Operation of PIP and POP

Picture Inside Picture (PIP) vs. Picture Outside Picture (POP)

You have the option to view two TV shows or inputs at the same time. For example, you can watch a game show and a sports event on another channel, or a DVD movie and more. The PIP option allows you to view another input as a picture-inside-picture. The POP option allows you to view a main picture and another input as a side-by-side or three or nine pictures-outside-picture at the side (only one moving POP).

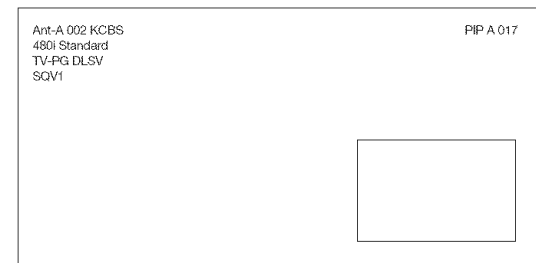
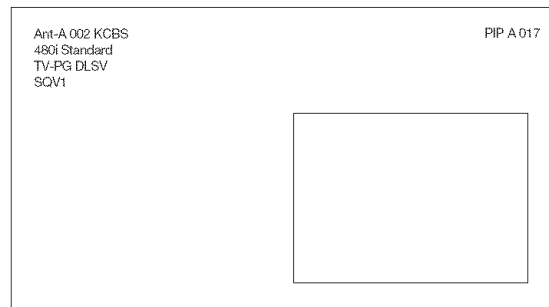
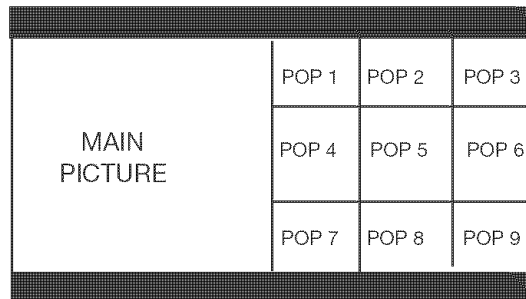
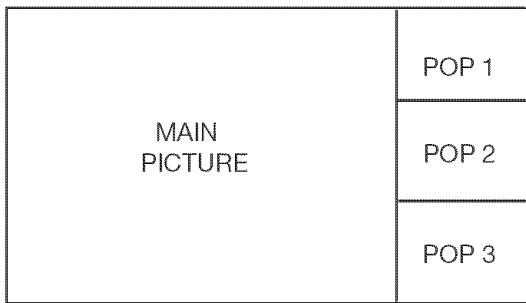
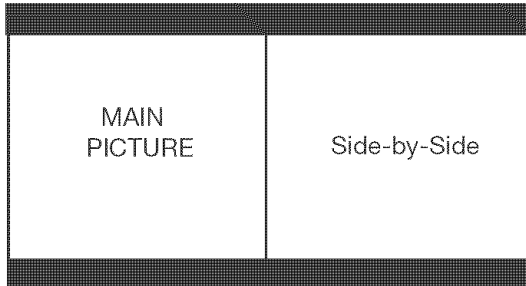

Changing PIP/POP Inputs

Press PIP INPUT to browse through available PIP or POP images.

Changing PIP/POP Channels

Press PIP CH to scroll up or down through memorized channels on the Ant-A and Ant-B.

Exchanging Program Images

Press ENTER/EXCH to exchange the main picture with the PIP / POP picture.

Moving PIP Images

Press ADJUST ▲, ▼, ◀, or ▶ to move the PIP display anywhere on the main screen.

Automatic POP Switching

When automatic POP switching is active, the TV will cycle through memorized analog channels on Ant-1 or Ant-2 or strobe pictures from other A/V components in the POP display. Press PAUSE to pause or restart automatic POP switching. While paused, only one of the POPs will show a “live” image.

Selecting POP “Live” Image

Press ADJUST ▲, ▼, ◀, or ▶ to select a different POP “live” image.

PIP Freeze, Side-By-Side Picture

Press PAUSE in the TV layer to freeze the PIP and side-by-side images. Press Pause again to return to a “live” image.

Appendix A: Bypassing the V-Chip Lock

Bypassing the V-Chip Lock

After you set the lock, you need your passcode to view a V-Chip locked program, view the locked TV, cancel the lock, or enter the V-Chip lock menus.

If you forget your passcode, you can view the locked TV without entering your passcode. When your password is requested, press the number 9 and QV buttons on the remote TV control at the same time. This process temporarily unlocks the TV.

When entering the V-Chip Lock menu, this process deletes your old passcode and prompts you to enter a new passcode.

IMPORTANT

Cut along the dotted line and file bypass instructions in a safe place for future reference.

IMPORTANT

When changing or deleting your passcode, you must use the remote control included with this TV. You cannot use a Mitsubishi remote control from another component or a "universal remote.

This page intentionally blank

Appendix B: High Definition Input Connection Compatibility

Component Inputs

These inputs are compatible with most standard DVD and DTV signals with component video outputs. Compatible DTV signals are SDTV 480i, 480p, and HDTV 1080i.

All other DTV signals, such as 720p, need to be converted by the DTV receiver (or compatible device) to one of the compatible signal types. Please check the specifications on your device before connecting.

DTV Input

These inputs are compatible with most standard DVD and DTV signals with component video outputs. Compatible DTV signals are SDTV 480i, 480p, and HDTV 1080i.

All other DTV signals, such as 720p, need to be converted by the DTV receiver (or compatible device) to one of the compatible signal types. Please check the specifications on your device before connecting.

This input is also compatible with some DTV receivers using RGB or RGB with “separate H and V sync.” Industry standards for DTV RGB signals systems, synchronization, timing, and signal strengths are not currently established. These inputs will not be compatible with all DTV receivers that offer RGB. If your DTV receiver offers both DTV component video signals and DTV RGB signals, Mitsubishi suggests you use the DTV component video signals. Please check the DTV receiver specifications before connecting.

Input Levels with Component Video

- Y = 1.0Vp-p (includes sync) 75ohms
- Pb = 700mVp-p, 75ohms (can also receive signals from outputs labeled B-Y and Cb)
- Pr = 700mVp-p, 75ohms (can also receive signals from outputs labeled R-Y and Cr)

Input Levels When Used With Component Video Signals

EIA - 770.3 Standard Levels

- Y = 1.0Vp-p (includes sync) 75ohms
- Pb = 700mVp-p, 75ohms
- Pr = 700mVp-p, 75ohms
- H = Not Used
- V = Not Used

Input Levels when Used With RGB Video Signals

- G (Y) = 1.0Vp-p 75ohms
(compatible with sync on green)
- B (Pb) = 700mVp-p, 75ohms
- R (Pr) = 700mVp-p, 75ohms
- H = 4Vp-p+/-1.0v, 2.2k ohms
(when using separate H and V sync)
- V = 4Vp-p+/-1.0v, 2.2k ohms

Input when Used With DVI

- HDCP compliant
- E-EDID (Enhanced-Extended Display Identification) 1.3 compliant
DVI-D uncompressed, high-speed, digital single-link connection
- Compatible scan rates are 1080i, 480p, 480i

Appendix C: Remote Control Programming Codes

A/V Receivers

Mitsubishi	010, 011, 012, 013, 014, 360
Admiral	220
Aiwa.....	225, 226, 241
B & K	352
Bose.....	351
Denon	234, 235, 236, 245, 246, 359, 361
Fisher	204
Gerrard.....	213
Harman Kardon	215, 223, 242, 362
Jensen.....	223, 229
JVC.....	232, 233
Kenwood.....	200, 208, 289
KLH	363
Koss	357
Magnavox	227, 228
Marantz	224, 350, 360
McIntosh	216
Nakamichi	206, 217
Onkyo.....	209, 214, 240, 247
Optimus	203, 227, 231, 230
Panasonic	219, 218, 221
Parasound	356
Philips	223, 248, 290
Pioneer.....	205, 207
Polk Audio.....	353
Quasar	219, 218, 221
RCA.....	203, 205, 227, 231, 230
Sansui	203, 211, 239
Sharp	234, 237
Sherwood	354, 355
Sony	222, 249, 364, 365
SoundDesign	238
TEAC	212, 213, 210, 211
Technics	221, 218, 219
Venturer.....	358
Victor.....	232, 233
Yamaha	201, 202, 243, 244

Cable Box

ABC	124
Archer	125
Cableview	105
Citizen	122, 105
Color Voice	128, 129, 130, 106,107
Comtronics	128, 129, 130 ,106,107
Curtis.....	112, 113
Diamond	124, 125
Eagle	129
Eastern.....	134
GC Brand.....	105
GE	112, 113
Gemini.....	122, 143
General Instrument	
/Jerrold.....	119, 120, 121, 123 124, 125, 126,127
Hamlin.....	112
Hitachi.....	103, 124
Macom.....	103, 104, 105, 108
Magnavox	128, 129, 130, 106, 107, 133, 138
Memorex.....	130
Movietime	105
Oak.....	102
Panasonic	114
Paragon	117
Philips	128, 129, 130, 106, 107, 133, 138, 131
Pioneer.....	101, 116
Pulsar	105
RCA.....	115
Regal	112
Regency.....	134
Rembrant	105, 138
Samsung.....	105
Scientific Atlanta.....	112, 113, 194
Signature.....	119, 124, 125, 126, 127, 120, 121, 122
SL Mark.....	105, 101
Sprucer	105,
Starcom	119, 124, 125, 126, 127, 120, 121, 122
Stargate	105
Televue.....	101, 105
Tocom	135, 136
Toshiba.....	104
Unika	125
United Artists.....	102
United Cable	119, 124, 125, 126, 127, 120, 121, 122
Universal	122
Videoway.....	106
Viewstar	129, 130
Zenith/ Drake Satellite.....	117, 100

DVD Players

Mitsubishi	003
Aiwa.....	261, 274
Apex.....	266, 283
Bose.....	286
Denon	250, 273
Ferguson.....	251
GE/RCA/Proscan	251, 256
Harman Kardon	282, 288
Hitachi.....	270
JVC	257
Kenwood.....	271, 289
Mintek	285
Next Base	284
Normande.....	251
Onkyo.....	267, 280
Oritron.....	263, 268
Paite	262
Panasonic	250
Philips/Magnavox	258, 253, 272, 290
Pioneer.....	252
Saba.....	251
Sampo	263
Samsung.....	261
Sanyo	275
Sharp	260
SMC	275
Sylvania.....	264
Sony	254, 278, 279
Thompson.....	251
Toshiba.....	253, 287
Venturer.....	281
Vialta	277
Wave	269
XWave	269
Yamaha	250, 272, 276, 287
Zenith	259

Appendix C: Remote Control Programming Codes, continued

Satellite Receivers /DBS/DTV

MitsubishiHD/Satellite Receiver.....	006, 173
Echostar/	
Dishnetwork.....	175, 82, 183, 188
Express Vu.....	175
GE.....	176
Gradient.....	186
Hitachi.....	173, 181, 184
Hughes.....	173
Maganavox.....	171, 172
Panasonic.....	174
Philips.....	171, 172
RCA/Proscan.....	176, 179, 180,185
Samsung.....	192
Sony.....	177
Star Choice.....	73
Toshiba.....	170, 189, 190, 191, 173
Uniden.....	171, 172
WebTV.....	187

VCRs

Mitsubishi.....	001, 002, 060, 067, 068, 061, 062
Admiral.....	055
Aiwa.....	047, 052
Akai.....	049, 034, 035, 036
Audio Dynamic.....	031
Bell & Howell.....	025
Broksonic.....	040, 046
Canon.....	043, 045
Citizen.....	026
Craig.....	025, 049, 026
Curtis Mathes.....	065, 044, 047
Daewoo.....	063, 021, 044, 078
DBX.....	030, 031
Dimensia.....	065
Emerson.....	023, 038, 039, 040, 045, 046, 062, 063
Fisher.....	025, 028, 029, 027
Funai.....	047, 046, 040,054
GE.....	065, 044, 079, 053
Go Video.....	057, 069, 070, 071
Goldstar.....	026
Gradiente.....	054
Hitachi.....	043, 065, 020,047
Instant Replay.....	044, 043
Jensen.....	059
JVC.....	030, 031, 054, 076, 077
Kenwood.....	030, 026, 031
LXI.....	047, 026, 020, 027, 028, 025, 029
Magnavox.....	051, 043, 044
Marantz.....	030, 031
Marta.....	026
Memorex.....	044, 029
MGA.....	060, 067, 068, 061, 062
Minolta.....	020, 065
Multitech.....	067, 047, 024
NEC.....	030, 031, 054
Olympic.....	044, 043
Optimus.....	048, 041, 055, 026
Orion.....	046, 040
Panasonic.....	043, 044, 041, 042
Penney.....	044, 020, 065, 025, 030, 031
Pentax.....	020, 031, 065
Philco.....	051, 044, 047, 043, 046, 040, 063
Philips.....	051, 043, 044
Pioneer.....	043
Proscan.....	065, 020, 043, 044, 051, 066, 021, 022, 053
Quasar.....	041, 042, 043, 044
Radio Shack.....	053, 044, 025, 056, 029, 060, 047

VCRs continued

RCA.....	053, 065, 020, 043, 044, 049, 051, 066, 021, 022
Realistic.....	044, 025, 056, 029, 060, 047
Samsung.....	057, 022, 024, 053
Sansui.....	046, 040, 072
Sanyo.....	025, 029
Scott.....	021, 022, 024, 029, 060, 067, 068, 046, 040
Sears.....	025, 026, 027, 028, 020
Shaintom.....	037
Sharp.....	055, 056
Signature 2000.....	047, 055
Singer.....	037
Sony.....	048, 049, 050, 073, 074, 075
SV2000.....	047
Sylvania.....	051, 043, 044, 047
Symphonic.....	047
Tashiro.....	026
Tatung.....	030, 031
TEAC.....	030, 047, 031
Technics.....	041, 042, 043, 044
Teknika.....	044, 047, 032
Toshiba.....	021
Totevision.....	026
Vector Research.....	031
Wards.....	055 056, 029, 064, 026
Yamaha.....	025, 030, 031
Zenith.....	064,026

Appendix D: Cleaning and Service

Cleaning

Normally, light dusting with a dry, non-scratching duster will keep your TV clean. If cleaning beyond this is needed, please use the following guidelines:

First, turn off the TV and unplug the power cord from the power outlet.

Top and Sides of the TV:

- Gently wipe down your TV with a soft, non-abrasive cloth such as cotton flannel or a clean cloth diaper, lightly moistened with water. Dry with a second dry, soft, non-abrasive cloth.
- For oily dirt, add a few drops of mild liquid detergent, such as dishwashing detergent to the water used to moisten the cloth. Rinse with a second cloth moistened only with water. Dry with a third dry, soft, non-abrasive cloth.

Screen:

- Follow the instructions for the top and sides, however, wipe gently in an up and down motion.
- Clean the entire screen evenly, not just sections of the screen.
- Do not allow liquid to drip down the front of the screen as some liquid may enter the TV between the screen and the screen frame.
- You may purchase Mitsubishi Screen Cleaner, part number CLEANER-VSS, by calling (800) 553-7278.

General Cleaning Warnings:

- DO NOT allow liquid to enter the TV through the ventilation slots or any crevice.
- DO NOT use any strong or abrasive cleaners as these can scratch the surfaces.
- DO NOT use any cleaners with ammonia, bleach, alcohol, benzine, or thinners as these can dull the surfaces.
- DO NOT spray liquids or cleaners directly on the TV's surfaces.
- DO NOT scrub or rub the TV harshly. Wipe it gently.

Service

If you are unable to correct a problem with your TV, consult your Mitsubishi dealer or a Mitsubishi Authorized Warranty Service Center.

- DO NOT adjust any controls other than those described in this Owner's Guide.
- DO NOT remove the front or protective back cover of your TV.

Menus not described and shown in this owner's guide are designed for Factory use and for Authorized Service Personnel. Damage caused to the TV by non-authorized changes or changes to these menus made by non-authorized persons are not covered under warranty.

I M P O R T A N T

Do not use any kind of abrasive or liquid Cleaner on the surface of the TV screen.

Appendix E: Cleaning the Dust Filter

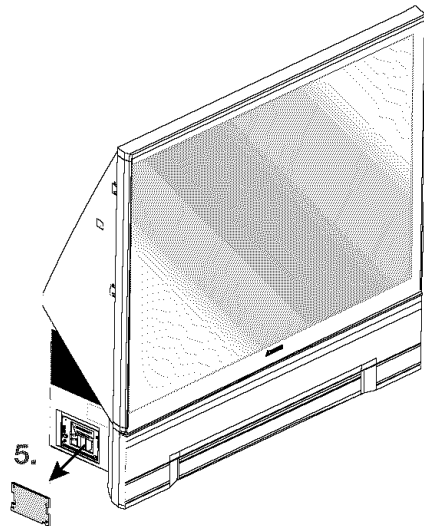
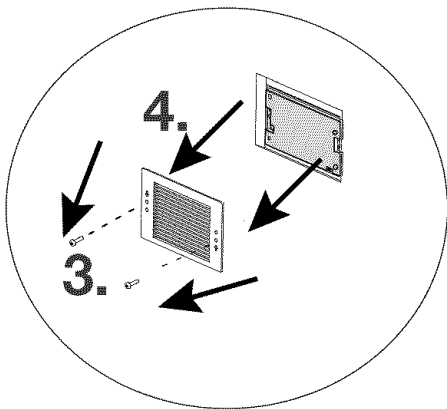
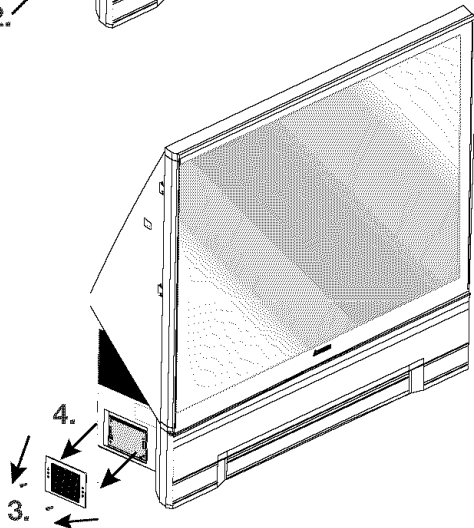
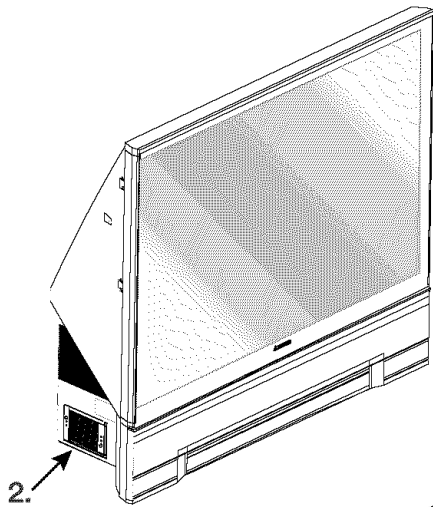

Cleaning the Dust Filter

Clean the filter annually and whenever you replace the lamp cartridge.

Tools needed: Phillips screwdriver

1. Turn the television off and unplug the AC cord.
2. Locate the dust filter on the left side panel of the TV.
3. Using a Phillips screwdriver, remove the two screws that hold the dust filter cover in place.
4. Remove the filter cover, set it and the screws aside.
5. Carefully remove the filter from the TV.
6. Clean the filter material by dusting with a lint-free cloth.
7. If the filter is soiled, you can rinse it with water. Do not use detergents or soap on the filter.
8. Completely air dry the filter before placing it back into the TV.
9. Replace the filter cover and secure with the screws.

Appendix F: Lamp Cartridge Replacement

Before you replace the lamp cartridge please note the following:

CAUTION: If the television is on, press POWER to turn off and allow the television to cool for one hour before attempting to replace the lamp cartridge.

LAMP LIFE

The light source for this television is a lamp, which is part of a lamp cartridge assembly. The actual life of the lamp in this television can vary, based on the lamp itself, the air temperature around the TV while it is operating, and your viewing patterns. Warmer air or poor ventilation shortens the lamp life, as does turning the television on and off frequently.

Mitsubishi warrants the lamp for one (1) year from date of the original purchase at retail. However, it is likely that the lamp will last significantly longer than this. When the end of the lamp's life is near, the TV will display a warning message for one minute, when the TV is powered on. The purpose of this message is to advise you that the lamp may fail soon. This warning message will continue to be displayed every time the TV is turned on, until the lamp cartridge is replaced and the lamp's status is reset.

After replacing the lamp cartridge, when you power on the TV, the message "Did you change the lamp? Press ENTER for Yes, press CANCEL for No" will appear, press ENTER to reset.

To order a new lamp cartridge, please call (800) 553-7278 and order part number 915P020010.

WARNING:

Do not remove the lamp cartridge immediately after turning off the television. You may get burned because of the lamp's high temperature. Allow the television to cool for one hour before attempting to replace the lamp cartridge.

Do not remove the lamp cartridge, except when replacing. Careless treatment can result in injury or fire.

Do not touch the lamp element directly. It may break and cause you to have injuries or burns.

Be sure not to insert any metal or flammable object into the lamp cartridge opening, as it may cause fire or electrical shock. If any object is inserted into the opening unplug the AC cord of the TV and contact your dealer for service.

Install the lamp cartridge securely. Failure to do so may cause a fire.

The lamp in this product contains mercury. Disposal of mercury may be regulated due to environmental considerations. For disposal or recycling information, please contact your local authorities or the Electronic Industries Alliance: www.eiae.org

Appendix F: Lamp Cartridge Replacement

Replacing the Lamp Cartridge

Tool needed: Phillips screwdriver

1. Turn the television off and unplug the AC cord.
2. Remove the front speaker grill by gently pulling on each side. The grill will snap out.
3. Using a phillips screwdriver, remove the three screws (one on the left and two on the right side) that hold the recessed plastic cover in place.
4. Remove the plastic cover and set aside with the screws.
5. After removing the cover, you will be able to see the lamp cartridge. With the screwdriver, loosen the three screws of the cartridge. **The three screws will not completely remove .**
6. Gently grasp the metal handle and pull straight out (towards you).
7. Insert the new lamp cartridge securely into the TV. Do not touch the glass surface of the cartridge.
8. With the screwdriver, tighten the screws on the lamp cartridge.
9. Replace the plastic cover and screws.
10. Snap the speaker grill back into place by pushing it into place on each side with the palm of your hand.

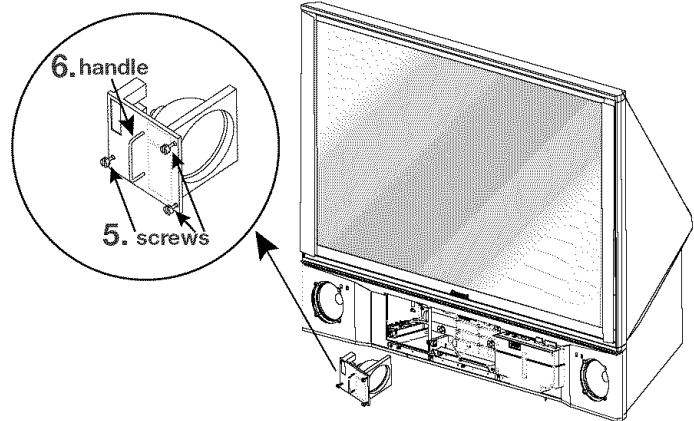
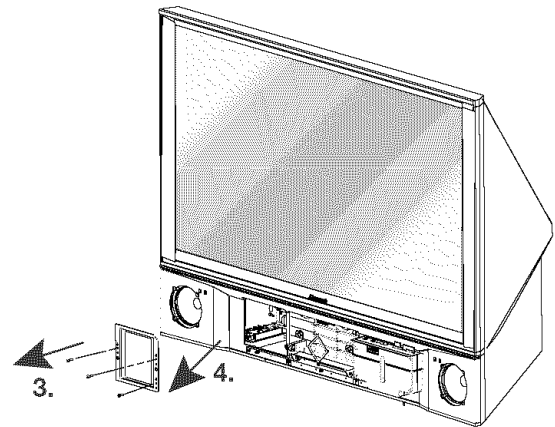
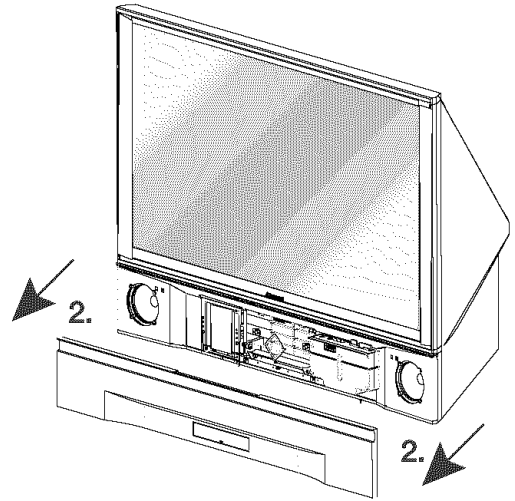

To order a replacement lamp cartridge, part number 915P020010, call (800) 553-7278.

Troubleshooting

	Problem	Possible Solution
1.	The TV remote control does not work.	<ul style="list-style-type: none"> • Check that the batteries are installed correctly. • Check that the selected switch is set to "TV". • Be no further than 20 feet from the TV when using the remote control.
2.	The TV takes several seconds to respond to channel commands.	<ul style="list-style-type: none"> • Press ENTER after a channel number to avoid delays. • Use the three digit number, i.e 002 for channel 2.
3.	You cannot access a channel.	<ul style="list-style-type: none"> • Use number keys instead of CHANNEL up/down. • Be sure the channel you want to view is in memory. • Check that the TV is turned to the correct input source for that channel, by pressing the INPUT button. • Make sure the V-Chip Lock is not set (pages 44-45).
4.	On-screen displays appear each time you change a function.	<ul style="list-style-type: none"> • This is part of normal TV operation.
5.	The TV cannot be programmed to turn on automatically.	<ul style="list-style-type: none"> • The TV may be locked. • The clock may not be set.
6.	There is no sound even when the volume is turned up.	<ul style="list-style-type: none"> • Check to see if the MUTE button is on. • The TV's "Listen to:" setting may be set to SAP. • Check that "TV Speakers" setting is On.
7.	You have forgotten your lock passcode.	<ul style="list-style-type: none"> • See Appendix A, Bypassing the V-Chip Lock (page 57).
8.	Connected devices do not work correctly when the TV is off.	<ul style="list-style-type: none"> • Energy mode has been set to Low. Change to Standard (page 36).
9.	Lamp indicator light is a constant red.	<ul style="list-style-type: none"> • Turn the TV off for at least 2 minutes. Turn back on. If light is still red, the lamp has failed, replace it. See Appendix F for lamp replacement information.
10.	Lamp indicator light is a constant yellow.	<ul style="list-style-type: none"> • Lamp's elapsed time has exceeded 5,000 hours. Purchase a new lamp. See Appendix F for lamp replacement information.
11.	Lamp indicator light is a flashing yellow.	<ul style="list-style-type: none"> • Lamp cover door is open or lamp cartridge is not secure. See Appendix F for lamp replacement information.
12.	Status indicator light is a constant yellow.	<ul style="list-style-type: none"> • Operating temperature or room temperature has exceeded proper levels. Clean the TV's dust filter or cool the room. See Appendix E for filter cleaning information.
13.	Status indicator light is a constant/flashing red.	<ul style="list-style-type: none"> • Service is required. Contact your dealer or a Mitsubishi Authorized Service Center to arrange for a service evaluation listings of Mitsubishi Authorized Service locations can be obtained from our web site, www.mitsubishi-tv.com or by calling 1-800-332-2119.
14.	PIP does not display a picture.	<ul style="list-style-type: none"> • Make sure the V-Chip Lock is not set (page 44-45). • Not all inputs can be displayed as a PIP (page 20).
15.	The sound does not match the screen picture.	<ul style="list-style-type: none"> • The TV's "Listen to:" setting may be set to SAP. • If using stereo or A/V receiver speakers, check input selection on the stereo or A/V receiver. • If using stereo or A/V receiver, check that AUDIO is from MONITOR OUT on TV's back panel.
16.	There is a large black or gray rectangle on the screen.	<ul style="list-style-type: none"> • TV closed captioning has been set to "text" mode, but no text information is being broadcast. Turn Off in the CAPTIONS menu (page 38).
17.	Picture is out of focus.	<ul style="list-style-type: none"> • Check the Sharpness settings (page 52).
18.	You cannot see a picture when you play a VCR tape.	<ul style="list-style-type: none"> • If you connected your VCR with A/V cables, use the INPUT button to select the Input source (INPUT-1, INPUT-2, or INPUT-3) that the VCR is connected to. • Check your VCRs owner's guide for further troubleshooting.

Troubleshooting, continued

19.	There is no picture when using MonitorLink/DVI input with an HDTV receiver or DVD player.	<ul style="list-style-type: none"> • Make sure device is set to Output DVI in Device Menu. • You may need to hook up to an analog input for initial setup. • Power TV off. Unplug DVI cable from device and plug back in. Power TV on first, then the DVI device.
20.	No picture displays when using component inputs.	<ul style="list-style-type: none"> • Make sure device is set to output at 480p or 1080i via YPbPr or RGB (check device output for compatibility).
21.	V-Chip is not working.	<ul style="list-style-type: none"> • Make sure that V-Chip is active (page 43-45). • If V-Chip Hours/Lock by Time is currently set to disable the V-Chip lock, the V-Chip will not block programming.
22.	Cannot set adjustments to factory setting.	<ul style="list-style-type: none"> • Follow the steps below to reset system defaults to factory settings: <ol style="list-style-type: none"> 1. Press the MENU button followed by number buttons 1,2,and 3 on the remote control. Result: The Reset System Default menu screen is activated. 2. Press the ENTER button on the remote control. Result: The settings reset to factory defaults. 3. Press HOME or MENU on the remote control to return to the HOME or MENU screen. <p>IMPORTANT: This function is not recommended unless it is mandatory to reset system defaults to factory settings. This operation CANNOT be undone and all customs settings will be erased.</p>

Additional Information

LICENSOR'S SUPPLIERS DO NOT MAKE OR PASS ON TO END USER OR ANY OTHER THIRD PARTY, ANY EXPRESS, IMPLIED OR STATUTORY WARRANTY OR REPRESENTATION ON BEHALF OF SUCH SUPPLIERS, INCLUDING, BUT NOT LIMITED TO THE IMPLIED WARRANTIES OF NON-INFRINGEMENT, TITLE, MERCHANTABILITY OR FITNESS FOR A PARTICULAR PURPOSE.

Digital Light Processing™ and DLP™ are trademarks of Texas Instruments.

MonitorLink™, ViewPoint®, QuickView™, SuperQuickView™ and PerfectColor™ are trademarks of Mitsubishi Digital Electronics America, Inc.

WARNING: This product contains chemicals known to the State of California to cause cancer and/or birth defects or other reproductive harm.

Index

A

A/V

- Memory Reset 50
- Receiver, Connecting 15

Activating the PIP and POP 28

Advanced Features Menu 32, 46-49

Antenna

- Channel Edit Menu 39-40
- Connecting 12, 13, 14

Appendices

- A: Bypassing the V-Chip Lock 57
- B: High Definition Input Connection Compatibility 59
- C: Remote Control Programming Codes 60-61
- D: Cleaning and Service 62
- E: Cleaning the Dust Filter 63
- F: Lamp Cartridge Replacement 64-65

Audio/Video Settings Menu 32, 50-52

- A/V Memory Reset 50
- Audio Output 50
- TV Speakers 50

Audio Settings Description 51

Automatic POP Switching 56

Auto Color Correction Menu 46

Available On-Screen Format Sizes 54-55

B

Back Panel Input/Output 10

Black Enhancement Menu 49

Bypassing the V-Chip Lock 57

C

Cable Box, Connecting 13, 14

Captions Menu 31, 37-38

- Background 38
- Closed Captions 38

Changing PIP/POP

- Channels 56
- Inputs 56

Channel Menu 39, 48

Channel Edit Menu 31, 39

Channel Selection 24

Clock Setting

- Auto 35
- Manual 34

Coaxial Lead Antenna, Connecting 12

Color Balance Menu 46

Component-1 and 2 Inputs Connection Compatibility 59

Composite Video with Audio, Connecting 14

Connecting

- Antenna
 - to a Cable Box and VCR 14
 - to a Cable Box 13
 - to a VCR 13
- or Wall Outlet Cable 12

Audio Receiver 15

DTV Receiver 17, 18

DVD Player 16

MonitorLink™ 19

S-Video Device 16

Connections Affect the PIP and POP 20

D

Daylight Savings Time Menu 35

DTV

Connectors and Adaptors 17

Input Connection Compatibility 59

DTV Receiver with

- Component Video Connections 17
- RGB Video Connections 18

DVD Player with Component Video 16

DVI, Connecting 19

E

Energy Mode 36

Entering the Passcode for V-Chip 43

Exchanging Program Images PIP and POP 56

F

Freeze the

- PIP 56
- Side-By-Side Picture 56

Front Button Lock 44

Front Control Panel 9

I

IMPORTANT

Safeguards 4-5

Input Menu 48

Input Assignment Menu 33

Input Levels 59

Input when used with DVI 59

L

Language Menu 36

Lock by Time 44

M

Main Menu Screens: Overview 31-32

Memorize Channels 33

Memorize 33

Memory 40

Menus (also see individual topic)

- Advanced Features 46-49
- Audio/Video Settings 50-52
- Captions 37-38
- Channel Edit 39-41
- Main 31-32

- Setup 33-36
- V-Chip Lock 42-45
- MonitorLink, Connecting 19
- Moving PIP Images 56

N

- Name Menu 40

P

- PerfectColor™ 46
- PIP and POP
 - Activating 28
 - Changing 56
 - Freezing 56
 - How Connections Affect 20
 - Operation 56
- POP “Live” Image, Selecting 56

R

- Remote Control Functions
 - Channel Selection 24
 - Operation 23
 - PIP and POP 28
 - Overview of the TV Layer Button 22
 - Sleep Timer 24
 - Special Functions 27
 - Use with Other Brands of A/V Products 25-26
- Reset Color 46

S

- S-Video
 - Audio, Connecting 14
 - Device, Connecting 16
- Separate UHF and VHF Antennas, Connecting 12
- Setting Up the V-Chip Lock Passcode 43
- Setup Menu 31, 33-36
- Set Day Menu 34, 48
- Set Time Menu 47
- Sleep Timer 24
- Special Features 8
- SQV™ Using the
 - Menu Screen 41
 - Remote Control 41
- Stereo Audio System, Connecting 15

T

- Timer Menu 47
- Time Zone Setting 35
- Troubleshooting 66-67
- TV Speakers Menu 50
- Twin Lead Antenna, Connecting 12

U

- Use of the Remote Control with Other A/V Products 25-26
- Using the AUDIO and VIDEO Buttons on the Remote Control 50

V

- V-Chip
 - Exceptions: 42
 - Ratings 42
- V-Chip Hours Menu 45
- V-Chip Lock Menu 32, 42-45
 - Overview 42
 - Signal Information 42
 - Start Time, Stop Time 45
- Video Mute 49
- Video Settings Description 52
- Video Settings 52
- Viewpoint Menu System 30

W

- Wall Outlet Cable, Connecting 12
- Warranty 70

Mitsubishi DLP™ Projection Television Limited Warranty

MITSUBISHI DIGITAL ELECTRONICS AMERICA, INC. (“MDEA”) warrants as follows to the original purchaser of this television that if purchased from an authorized MITSUBISHI Audio/Video Dealer, should it prove defective by reason of against defects arising from improper workmanship and/or material:

a. Parts. The lenticular (i.e. front picture) screen and/or the Diamond Shield™ is warranted against defects in materials and workmanship for a period of thirty (30) days from the date of the original purchase at retail-. The VIP lamp and all other parts (except any software incorporated into this television) are warranted for a period of one (1) year from the date of the original purchase at retail. We will repair or replace, at our option, any defective part without charge for the part. Parts used for replacement may be replaced with those of like kind and quality and may be new or remanufactured. Parts used for replacement are warranted for the remainder of the original warranty period.

b. Embedded Software. MDEA warrants that all software incorporated into this television set (the “Embedded Software”) will perform in accordance with the functional description of Embedded Software in all material respects, but MDEA does not warrant that the Embedded Software is error-free. MDEA also does not warrant that the Embedded Software will be compatible under IEEE 1394 AV/C and HAVi software standards with products produced by any other manufacturer. The warranty contained in this section shall continue for a period of one (1) year from the date of the original purchase at retail-. If, after prompt notice within the warranty period, MDEA determines that the Embedded Software has failed to perform in accordance with such functional description in all material respects and if such failure is not due to accident, misuse, modification or misapplication of the Embedded Software, then MDEA shall modify or replace the nonconforming Embedded Software at no charge to you, which at MDEA’s sole discretion may be fulfilled by means of modification or replacement software contained on a replacement media card for Customer installation. The foregoing shall be MDEA’s sole obligation to you under this limited warranty. All rights under this limited warranty on the Embedded Software also subject to your compliance with the terms of the Software License Agreement applicable to this television, and this limited warranty on the Embedded Software shall be null and void if the Embedded Software is modified or changed in any manner except as specifically authorized by MDEA.

c. Labor. For thirty (30) days after the original purchase at retail, we will repair or replace, at our option, the lenticular screen if it proves defective. For certain items that are designed to be replaced by the consumer, including (but not limited to) the Diamond Shield™ and/or some Embedded Software, the consumer is solely responsible for any replacement labor. The VIP lamp is consumer replaceable and labor for replacement is not covered under warranty, please refer to the Owner’s Guide for replacement procedures. Air filter cleaning is normal consumer required maintenance and labor for this procedure is not covered under warranty, please refer to the Owner’s Guide for air filter cleaning procedures. For all other parts, we will provide the labor for a warranty repair by an authorized MITSUBISHI service center without charge for one (1) year from the original date of purchase at retail.

d. Notice. To obtain warranty service, you must notify an authorized MITSUBISHI service center of any defect within the applicable warranty time period.

e. This DLP™ Projection Television uses a revolutionary technology, Digital Micromirror Device™, to create the screen image. This technology creates the image using small dots, or picture elements (pixels). Your DLP Projection TV is manufactured to a high level of performance and quality, in fact, 99.99% perfect in the number of properly functioning pixels. As in other display technology, sometimes a pixel is continuously active, inactive or the incorrect color. Our standard is clear; MDEA warrants only that the percentage of properly functioning pixels will be not less than 99.99% of all pixels.

BEFORE REQUESTING SERVICE, please review the instruction booklet to insure proper installation and correct customer control adjustment. If the problem persists please arrange for warranty service.

1. TO OBTAIN WARRANTY SERVICE:

a. Contact your nearest authorized MITSUBISHI service center whose name and address can be obtained from your MITSUBISHI dealer, by writing at the address provided below, calling MDEA at the 800-332-2119, or use the support feature of our website at www.mitsubishi-tv.com.

b. Warranty service will be provided in your home or, if required, at an authorized service shop, provided that your television is located within the geographic territory customarily covered by an authorized MITSUBISHI service center. If not, you must either deliver your television to an authorized service location at your own expense, or pay for any travel and/or transportation costs the service center may charge to and from your home. Actual service labor will be provided without charge.

c. Proof of purchase date from an authorized MITSUBISHI dealer is required when requesting warranty service. Present your sales receipt or other document which establishes proof and date of purchase. THE RETURN OF THE OWNER REGISTRATION CARD IS NOT A CONDITION OF WARRANTY COVERAGE. However, please return the Owner Registration Card so that we can contact you should a question of safety arise which could affect you.

d. To obtain a replacement VIP lamp during the warranty period, please contact the MDEA Consumer Relations Department at (949) 830-8364. After the warranty period you may order the lamp directly from the MDEA Parts Department at (800) 553-7278.

2. THIS WARRANTY DOES NOT COVER:

a. Up to .01% pixel outages (small dot picture elements that are dark or incorrectly illuminated).

b. Damage to the lenticular screen or Fresnel lens, screen frame, cosmetic damage or to any other damage where such damage is caused by unauthorized modification, alteration, repairs to or service of the product by anyone other than an authorized MITSUBISHI service center; physical abuse to or misuse of the product (including any failure to carry out any maintenance as described in the Owner's Guide including air filter cleaning or any product damaged by excessive physical or electrical stress); any products that have had a serial number or any part thereof altered, defaced or removed; product use in any manner contrary to the Owner's Guide; freight damage; or any damage caused by acts of God or other factors beyond the reasonable control of MDEA, such as power surge damage caused by electrical system or lightning. This warranty also excludes service calls where no defect in the product covered under this warranty is found, service calls related to unsatisfactory audio or visual reception or signal unless caused a defect in the product that is covered under this warranty, all costs, expenses or any other damages arising from product installation, or set-ups, any adjustments of user controls (including contrast, brightness, color, tint, fine tuning, sharpness), other adjustment necessary to prepare the unit for display or use, connection with any external audio receiver, antenna, cable or satellite systems, or service of products purchased or serviced outside the U.S.A. Please consult the operating instructions contained in the Owner's Guide furnished with the product for information regarding user controls.

3. ANY EXPRESS WARRANTY NOT PROVIDED HEREIN, AND ANY REMEDY WHICH, BUT FOR THIS PROVISION, MIGHT ARISE BY IMPLICATION OR OPERATION OF LAW, IS HEREBY EXCLUDED AND DISCLAIMED. THE IMPLIED WARRANTIES OF MERCHANTABILITY AND OF FITNESS FOR ANY PARTICULAR PURPOSE ARE EXPRESSLY LIMITED TO A TERM OF ONE YEAR.

4. UNDER NO CIRCUMSTANCES SHALL MDEA BE LIABLE TO PURCHASER OR ANY OTHER PERSON FOR ANY INCIDENTAL, SPECIAL OR CONSEQUENTIAL DAMAGES, WHETHER ARISING OUT OF BREACH OF WARRANTY, BREACH OF CONTRACT, OR OTHERWISE.

5. Some states do not allow limitations on how long an implied warranty lasts, or the exclusion or limitation of incidental, special, or consequential damages, so the above limitations or exclusions may not apply to you.

6. This warranty gives you specific legal rights, and you may also have other rights which vary from state to state.

MITSUBISHI DIGITAL ELECTRONICS AMERICA, INC.

9351 Jeronimo Road

Irvine, CA 92618-1904



If you have questions that cannot be answered from this book, please call our Consumer Relations advisors at (800) 332-2119 or send an email to: MDEAservice@mdea.com

To order replacement remote controls, an Owner's Guide or lamp cartridge, please call our Parts Department at (800) 553-7278 or contact us through our web site at: www.Mitsubishi-tv.com