

# **125BT** **Power Blower**

## **Operator's manual** **Manuel d'utilisation**



Read through the Operator's manual carefully and understand the content before using the machine.



Lire attentivement le manuel d'utilisation et assimiler son contenu avant d'utiliser la machine.



**WARNING:**



The engine exhaust from this product contains chemicals known to the State of California to cause cancer, birth defects or other reproductive harm.



# Safety instructions

## Supplementary explanations

### General

- Improper operation may cause injuries to the user or persons nearby. Loss of sight may also occur. To prevent injuries, be sure to observe the following instructions.
  - Before operating the blower, be sure to fully read, understand and follow the instructions in the Operator's Manual, safety regulations and warnings.
  - The blower must be operated only by persons who understand the instructions in the Operator's Manual, safety regulations and warnings.
- Do not allow children to use the blower. Use the blower only for purposes described in the Operator's Manual.

### Environment

Do not operate the blower in the following locations or conditions. It could cause injuries or an accident.

#### WARNING

- The exhaust gases include dangerous gases such as carbon monoxide, so do not operate the blower indoors in enclosed spaces. Prevent operating the blower in dangerous locations. Do not operate the blower where there is no ventilation, where there are flammable or explosive gases, or where carbon monoxide accumulates.
- Never operate the blower so that exhaust from the muffler is blocked off. Always maintain a clearance of 1 meter or more from the muffler.

- Do not operate the blower when you are tired, ill, upset, or if you are under the influence of alcohol, drugs, or medication.
- Keep children, bystanders and pets away from the work area a minimum of 10 meter when starting or operating the unit.
- Before operating the blower, remove all debris and objects such as stones, glass, wire, etc. that can be blown or cause damage during operation.
- Do not operate the blower where your position is unstable, such as on a ladder, up a tree or on a steep slope.(Fig.1)
- Start the blower engine at least 3 meters away from the location where you poured fuel into the blower fuel tank.(Fig.2)
- Operate the blower in accordance within the operation times permitted by your local noise control regulations to prevent inconveniencing surrounding people.

### Clothing

Wear the following clothing and equipment to prevent injuries and accidents.(Fig.3)

#### WARNING

- Wear safety glasses that comply with ANSI Z87.1 requirements in order to protect your eyes and face from stones and fragments that may be blown toward you.
- Wear a filter face mask when operating the blower where there is a lot of dust.
- Wear earplugs or protective headphones to protect your ears from noise while operating the blower.
- If you have long hair, wear a hat or hairnet.

- Wear long pants and boots or safety shoes. Do not wear jewellery accessories.
- Do not wear short pants, sandals or go barefoot. Wear clothing that is close-fitting and easy to move in.

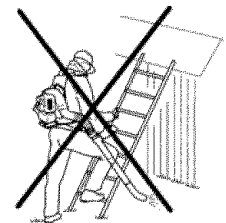

Fig.1



Min. 3 m  
(10 ft)

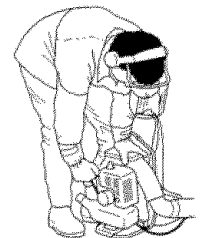
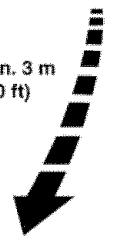

Fig.2



Fig.3

## Flame Strictly Forbidden

To prevent an accident or fire, strictly observe the following instructions when handling fuel or operating the blower.(Fig.4)

### WARNING

- Fuel is flammable. Operate the blower only where there is no flame.
- If you are storing or mixing fuel, do it where there is no flame.
- While operating the blower, keep away from flames.
- Do not smoke while handling fuel or operating the blower.
- Do not add fuel while the engine is hot. Wait until the engine is cool.
- Do not add fuel to the fuel tank while the blower engine is operating.



Fig.4

## Before Operation

To prevent injuries and accidents, check the following items before operating the blower.

### WARNING

- If you discover fuel leakage, do not start the blower.
- Check that the anti-vibration rubber has no cracks or damage.
- Make sure the tank cap is tightened securely. If it is loose or not installed level, fuel could leak and be extremely dangerous.
- Do not modify the blower. In particular, never perform modifications to deliberately increase the engine speed.
- Always check that the muffler is not damaged or corroded. A worn or damaged muffler may produce sparks or flame and is dangerous.(Fig.5)

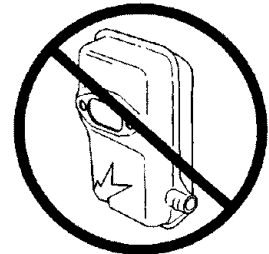

Fig.5

- To reduce noise, do not operate two or more blowers at the same time.
- Before starting the blower, check that there is no fuel leakage around the fuel hose, fuel tank and carburetor.
- When you start the blower engine, push the blower toward the ground with one hand on top of the body while you pull the starter cord.(Fig.6)
- Hold the start cord handle firmly. Do not pull it too hard and do not release it suddenly.
- When performing repairs or replacing parts, use genuine factory parts.
- Before operating the blower, check each part (particularly the muffler, intake port and air filter) for wear, looseness and damage.
- Check that the blower condition is normal. If the blower is not normal, do not operate it.
- Check that there is no oil or fuel on the machine exterior. If you get oil or fuel on the machine exterior, wipe it off promptly and wait until the machine is fully dry before operating the blower.
- Operate a separate container for mixing fuel. Do not operate the blower fuel tank to mix fuel.
- Before you start the engine, check there are no foreign objects within the housing.

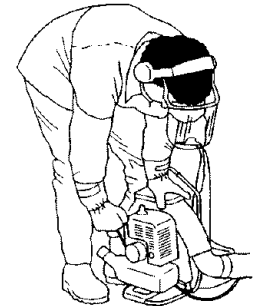

Fig.6

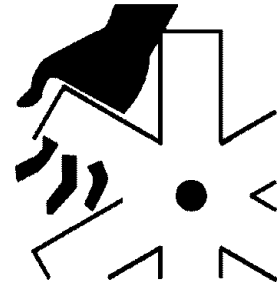

Fig.7

## During Operation

Take care with the following items during blower operation to prevent personal injuries, accidents or machine breakdown.

### WARNING

- The blower generates powerful suction, so do not operate the blower when wearing loose clothes and unrestrained long hair.
- Keep your hand away from the blower intake port during operation. The fan operates at high speed and is dangerous.(Fig.7)
- Do not insert anything into the blower intake port during operation.
- Do not perform maintenance, disassembly or reassembly during blower operation.
- There is danger of electric shock and burns during blower operation and immediately afterward, so do not touch the spark plug, muffler or engine cover.(Fig.8)(Fig.9)



Fig.8



Fig.9

- Operate the blower correctly. Do not hold the body in your hands when operating the blower.
- The fan operates constantly during blower operation, so take care to prevent it.
- The blower operates the fan at high speed to generate wind. Do not apply shocks or external force to the machine during operation.
- Do not insert anything into the pipe. Always take care to prevent blowing fragments at persons, animals, plants, trees, vehicles and walls.
- Take care with the air pressure. Flying stones, dust and branches can injure persons and animals, and break glass.(Fig.10)
- Do not point the pipe outlet port toward people or animals.
- Do not operate the blower to spread substances that may be injurious to humans, such as chemicals, fertilizers and poisons.
- If you detect abnormal vibration or noise during operation, promptly stop the blower and check whether something has broken. If a breakdown has occurred, do not operate the blower until the problem is fixed.
- Before you start the blower, make sure that all attachments such as the pipe are installed securely. If installation is incomplete, performance may be reduced, the engine speed may drop, and an accident or breakdown may occur.
- Check that the housing intake port and pipe output port are not blocked by leaves or waste, etc.  
If the housing intake port or pipe output port is blocked, blower performance is reduced and damage may result from engine overheating.
- If the housing intake port or pipe output port is blocked, stop the engine and remove the leaves or waste, etc.(Fig.11)
- Do not remove the fuel cap during or immediately after blower operation.
- Always stop the engine when halting work or performing maintenance. Before you perform maintenance, also remove the spark plug.
- If the engine does not stop when you operate the stop switch, turn the choke to a fully closed position in order to stop the engine.

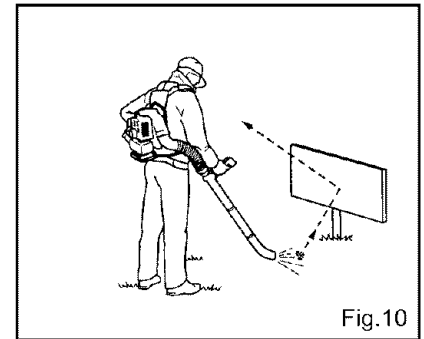

Fig.10

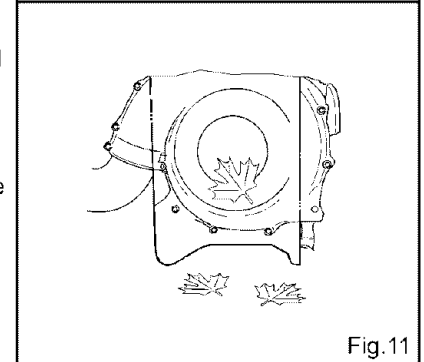

Fig.11

## After Operation

When you have finished operating the blower, store the blower in accordance with the following instructions to prevent the danger of fire or an accident.

### WARNING

- When you release the fuel cap, turn the fuel cap slowly to gradually release the internal pressure generated in the fuel tank.
- Drain the fuel before storing or transporting the blower. Do not store the blower with fuel still remaining in the tank, hose and carburetor.
- Store the blower away from humidity and flames, and out of reach of children.
- Store the fuel in a receptacle certified suitable for flammable fluids.
- Store the blower after the engine has cooled down completely.
- The engine is hot immediately after it has stopped, so do not place it near flammable items.

# CONTENTS



**WARNING!**  
Under no circumstances should you modify the original design of the blower without approval from the manufacturer. Always use genuine spare parts. Unauthorised modifications or accessories may lead to serious injury or death.

## EMISSION CONTROL INFORMATION

### Fuel Information

THIS ENGINE IS CERTIFIED TO OPERATE ON UNLEADED REGULAR GRADE GASOLINE ONLY.

A minimum of 87 octane of the antiknock Index is recommended. The antiknock index is

Posted on service station pumps in the U.S.A..

### Emission Control Information

To protect the environment KAWASAKI has Incorporated exhaust emission control system (EM) In compliance with applicable regulations of the California Air Resources Board.

#### 1. Exhaust Emission Control System

The exhaust emission control system applied to this engine consists of a carburetor and an ignition system having optimum ignition timing characteristics.

The carburetors have been calibrated to provide lean air/fuel mixture characteristics and optimum fuel economy with a suitable air cleaner and exhaust system.

### Maintenance and Warranty

Proper maintenance is necessary to ensure that your engine will continue to have low emission levels. This Owner's manual contains those maintenance recommendations for your engine.

Those items identified by the periodic Maintenance Chart are necessary to ensure compliance with the applicable standards.

The KAWASAKI Limited Emission Control System Warranty requires that you return your engine to an authorized KAWASAKI engine Dealer for remedy under warranty. Please read the warranty carefully, and keep it valid by complying with the owner's obligations it contains.

### Tampering with Emission control System Prohibited

Federal law and California State Law prohibits the following acts or the causing thereof :

(1) the removal or rendering inoperative by any person other than for purposes of maintenance, repair, or replacement, of any device or element of design incorporated into any new engine for the purposes of emission control prior to its sale or delivery to the ultimate purchaser or while it is in use, or (2) the use of the engine after such device or element of design has been removed or rendered inoperative by any person.

Among those acts presumed to constitute tampering are the acts listed below:

Do not tamper with the original emission related parts:

- Carburetor and internal parts
- Spark Plug
- Magneto or electronic ignition system
- Fuel Filter
- Air cleaner element

## List of contents

### CONTENTS

List of contents .....	4
<b>SYMBOL EXPLANATION</b>	
Symbols .....	5
<b>SAFETY INSTRUCTIONS</b>	
Personal protective equipment .....	6
The machine's safety equipment .....	6
Control, maintenance and service of the machine's safety equipment .....	8
General safety instructions .....	9
General working instructions .....	10
Basic working techniques .....	11
<b>WHAT IS WHAT?</b>	
What is what on the blower? .....	12
<b>ASSEMBLY</b>	
Assembly of the blower .....	13
<b>FUEL HANDLING</b>	
Fuel mixture .....	14
Fuelling .....	14
<b>START AND STOP</b>	
Start and stop .....	15
<b>MAINTENANCE</b>	
Carburettor .....	16
Muffler .....	17
Cooling system .....	17
Spark plug .....	17
Air filter .....	18
Maintenance schedule .....	18
<b>TECHNICAL DATA</b>	
125BT .....	20

# SYMBOL EXPLANATION

## Symbols



**WARNING!**  
Careless or incorrect use of the blower can result in serious damage or fatal injury to the operator or others.



Read through the Operator's Manual carefully and understand the content before using the machine.



Always use

- A protective helmet where there is a risk of falling objects
- Ear protection
- Approved eye protection



- Always wear approved protective gloves.



- Use anti-slip and stable boots.

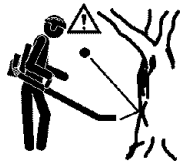

- **WARNING!** The blower may throw objects at high velocity that can ricochet and hit the operator. This may cause serious eye damage.



- The blower operator must make sure that no bystanders or animals come nearer than 10 metres. Whenever several operators are working in the same work area, they should maintain a safe distance of at least 10 metres from one another.

**Other symbols/decals on the machine refer to special certification requirements for certain markets.**

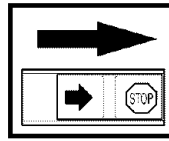

Checks and/or maintenance should be carried out with the engine switched off, with the stop switch in the STOP position.

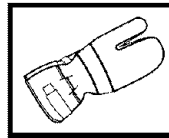

Always wear approved protective gloves.

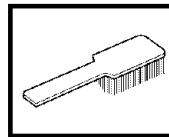

Regular cleaning required.

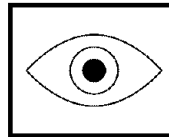

Ocular control.

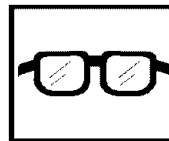

Approved eye protection must always be used.

# SAFETY INSTRUCTIONS

## Personal protective equipment

### IMPORTANT INFORMATION

- A blower used incorrectly or carelessly can become a dangerous tool, which can cause serious damage or fatal injury to the operator or others. It is very important that you read and understand the content in this manual.
- When using a blower, personal protective equipment approved by the appropriate authorities must be used. Personal protective equipment does not eliminate the risk of accidents, but it reduces the effects of an injury in the event of an accident. Ask your dealer for help when choosing protective equipment.



### WARNING!

Remove your hearing protection as soon as you stop the engine, so that you can hear any noises or warning signals.

### EAR PROTECTION

Ear protection offering sufficient dampening effect should be used.

### EYE PROTECTION

Blows from branches, or whirling objects can lead to eye injuries.

### BOOTS

Use anti-slip and stable boots.

### CLOTHING

Wear clothes made of a strong fabric and avoid loose clothing that can catch on shrubs and branches. Always wear heavy, long pants. Do not wear jewelry, short pants, sandals or go barefoot. Secure hair so it is above shoulder level.

### FIRST AID KIT

A first aid kit should be carried by operators of clearing saws, brushcutters or trimmers.

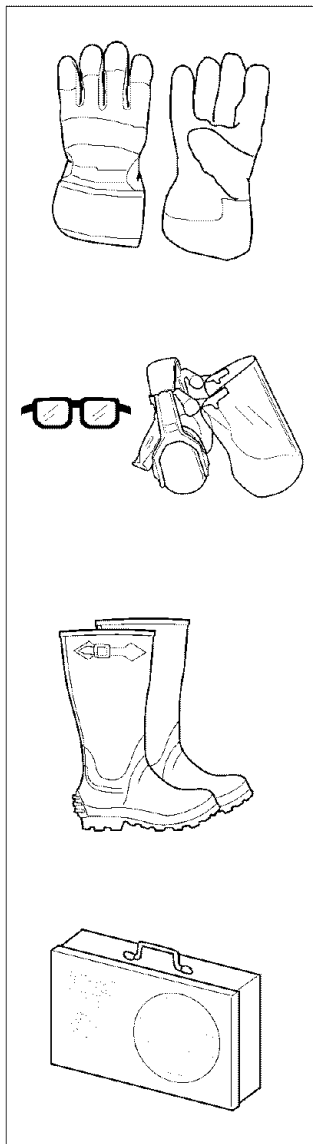

### BREATHING PROTECTION

Breathing protection should be worn if there is a risk of dust.

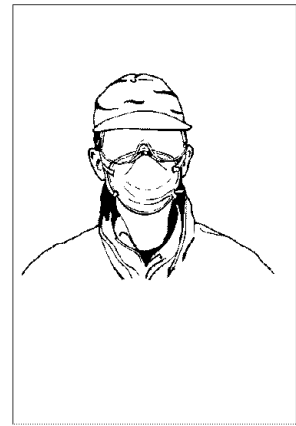

## The machine's safety equipment

This section describes the machine's safety equipment, its function and how checks and maintenance are carried out to ensure that it operates correctly. (See the chapter "What is what" to locate where this equipment is positioned on your machine.)



### WARNING!

Never use a machine with defective safety equipment. Follow the control, maintenance and service instructions described in this section.

### 1. Stop switch

The stop switch should be used to stop the engine.

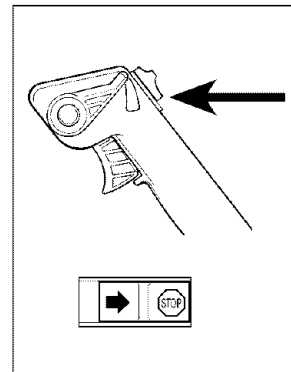

# SAFETY INSTRUCTIONS

## 2. Vibration damping system

Your machine is equipped with a vibration damping system, which is designed to give as vibration-free and comfortable use as possible.

The machine's vibration damping system reduces the transfer of vibrations.

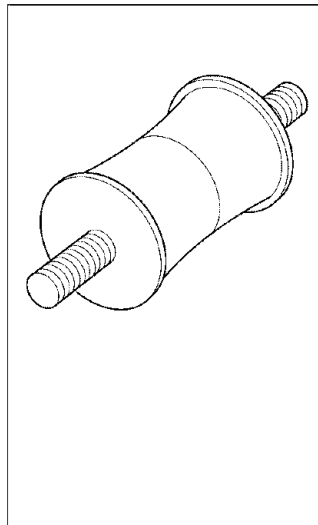

**WARNING!**  
Over exposure to vibrations can result in blood-vessel or nerve injury to persons suffering with blood circulation problems. Seek medical attention if you experience physical symptoms that can be related to over exposure to vibrations. Examples of such symptoms are "numbness", lack of feeling, "tickling", "pricking", "pain" lack of or a reduction in normal strength, changes in the colour of the skin or its surfaces. These symptoms normally appear in the fingers, hands or wrists.

## 3. Muffler

The muffler is designed to give the lowest possible noise level and to direct the engine's exhaust fumes away from the operator. Muffler fitted with catalytic converter is also designed to reduce harmful exhaust components.

In countries that have a warm and dry climate the risk of fire is obvious. We have therefore fitted certain mufflers with a spark arrest screen. Make sure that your muffler is fitted with this kind of screen.

It is extremely important that the instructions for checking, maintaining and servicing the muffler are followed. (see the section "*Control, maintenance and service of the machine's safety equipment*").

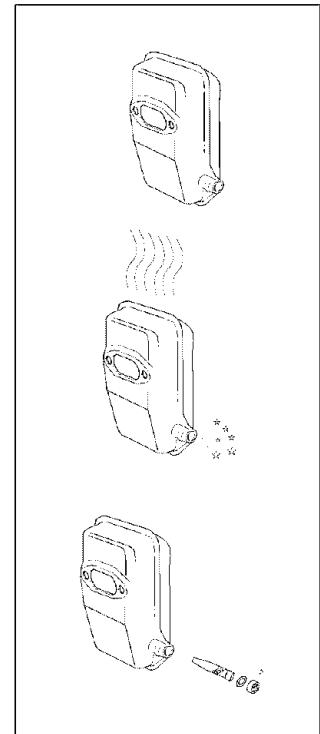

**WARNING!**  
Mufflers fitted with catalytic converters become extremely hot during use and after stopping. This also applies at idling speeds. Contact can result in burns to the skin. Be observant to the risk of fire!



**WARNING!**  
Bear in mind that exhaust fumes:

- contain carbon monoxide, which can cause carbon monoxide poisoning. Therefore never start or run the machine indoors.
- are hot and can contain sparks that can cause fires. Never start the machine indoors or close to inflammable material.



# SAFETY INSTRUCTIONS

## Control, maintenance and service of the machine's safety equipment

### IMPORTANT INFORMATION

- All service and repairs to the machine require special training.
- This applies especially to the machine's safety equipment. If the machine does not meet any of the controls listed below you should contact your service workshop.
- The purchase of one of our products guarantees that professional repair and servicing will be carried out on it. If the point of purchase is not one of our servicing dealers, please ask for details of the closest service workshop.

### 1. Stop switch

- Start the engine and make sure that the engine stops when the stop switch is moved to the stop position.

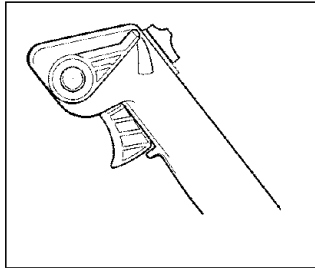

### 2. Vibration damping system

- Check the vibration damping element regularly for material cracks and distortion.
- Check that the vibration damping element is undamaged and securely attached.

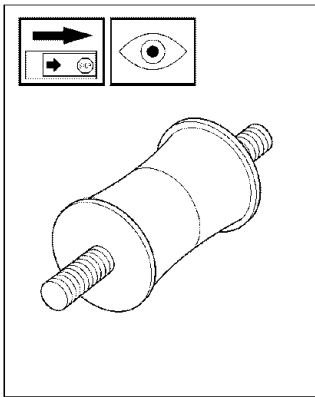

### 3. Muffler

1. Never use a machine that has a defective muffler.
2. Check regularly that the muffler is secure.
3. If your muffler is fitted with a spark arrest screen then it should be cleaned regularly. A blocked screen leads to the engine overheating with serious damage as a result. Never use a muffler with a defective spark arrest screen.

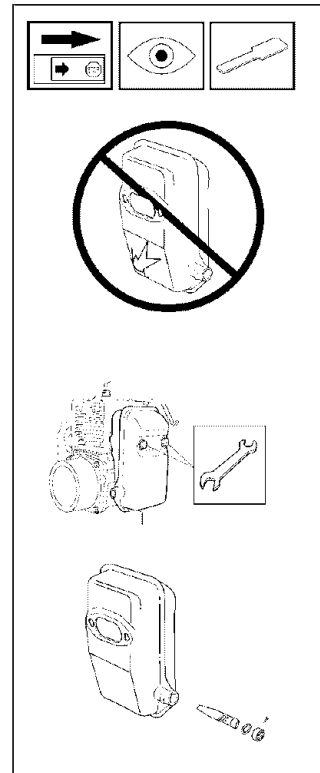

#### WARNING!

Never use a machine with defective safety equipment. The safety equipment should be maintained as described in this section. If your machine does not meet any of these controls you should contact your service workshop.

# SAFETY INSTRUCTIONS

## General safety instructions

### IMPORTANT INFORMATION

- The only accessories to be used with the engine unit as a drive source are the cutting units we recommend in the chapter *“Technical data”*.
- Never use the machine if you are tired, if you have consumed alcohol, or if you are taking medicines that can affect your sight, your judgement or the control of your body.
- Use personal protective equipment. See the section *“Personal protective equipment”*.
- Never use a machine that has been modified so that it no longer corresponds with the original design.
- Never use a machine that is faulty. Follow the maintenance, control and service instructions in this Operator's Manual. Some maintenance and service actions should be carried out by trained and qualified specialists. See the chapter *“Maintenance”*.
- All covers and guards must be fitted before starting the machine. Check that the spark plug cap and HT lead are not damaged, otherwise you could get an electric shock.
- The machine operator shall ensure, while working, that no persons or animals come closer than 15 metres (50 feet). When several operators are working in the same area the safety distance should be at least double tree length, however, at least 15 metres (50 feet).

## Start

- Never start the machine indoors. Bear in mind the dangers of inhaling the engine's exhaust fumes.

Observe your surroundings and make sure that there is no risk of people or animals coming into contact with the blown air.

- Place the machine on the ground, ensure the cutting equipment runs free of twigs and stones. Push the machine body towards the ground using your left hand. (NOTE! Not with your foot). Grip the starter handle with your right hand and pull the startercord.

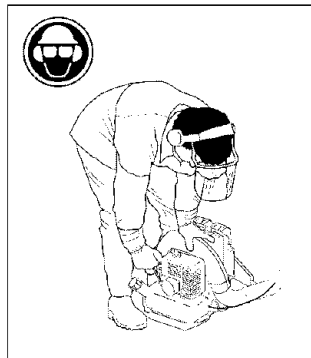

## Fuel safety

- Always use a fuel container with an anti-spill valve.
- Never fill the machine while the engine is running. Always stop the engine and let it cool for a few minutes before refuelling.
- Provide good ventilation when filling or mixing fuel (petrol and 2-stroke oil).
- Move the machine at least 3 m from the filling position before starting.
- Never start the machine:
  - a) If you have spilt fuel on it. Wipe up all spillage.
  - b) If you have spilt fuel on yourself or your clothes. Change your clothes.
  - c) If there is a fuel leak. Make regular checks for leakage from the fuel cap and the fuel supply pipes.

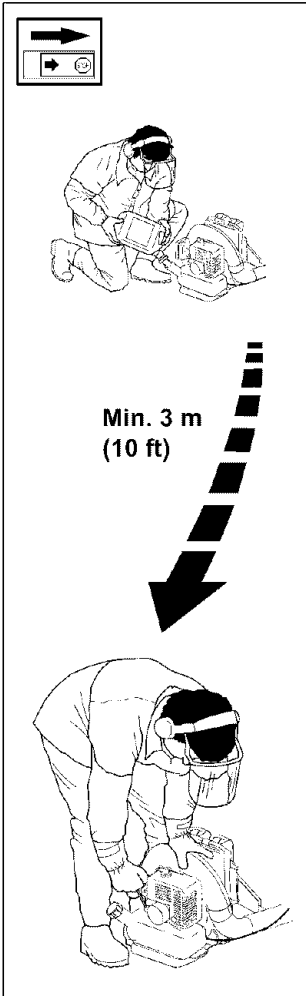

## Transport and storage

- Store and transport the machine and fuel so that any leakage or fumes do not risk coming into contact with sparks or naked flames. For example, electric machines, electric motors, electrical switches/power switches, heaters or the like.
- When storing and transporting fuel approved containers intended for this purpose must be used.
- When storing the machine for long periods the fuel tank must be emptied. Contact your local petrol station to find out how to dispose of excess fuel.



**WARNING!**  
Exercise great care when handling fuel.  
Bear in mind the risk of fire, explosions and inhaling fumes.

# SAFETY INSTRUCTIONS



## WARNING!

Always use the harness when working with the machine, otherwise it will not be possible to operate it safely and this can result in injury to yourself or others. Never use a harness with a faulty quick release.

## Equal load on shoulders

A well-adjusted machine and harness simplify working considerably. Adjust the harness to give the best working stance. Adjust the side straps so that the weight is equally divided across the shoulders.

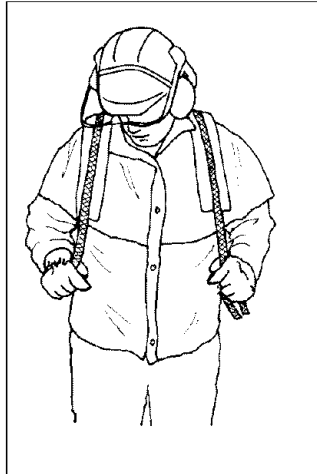

## General working instructions

### IMPORTANT INFORMATION

- This section considers basic safety rules when working with blowers.
- If you encounter a situation where you are uncertain how to proceed you should ask an expert. Contact your dealer or your service workshop.
- Avoid all usage which you consider to be beyond your capability.

### Basic safety precautions

Show consideration to persons in your surroundings by avoiding using the machine at unsuitable times, such as late in the evening or early in the morning. Read through and follow the simple directions so that you disturb your surroundings as little as possible.

- Use the blower with the lowest possible throttle. It is seldom necessary to use full throttle, and many work procedures can be done at half throttle. A lower throttle means less noise and less dust, and it is also easier to keep control over the rubbish collected together/moved.
- Use a rake or a brush to release rubbish stuck to the ground.
- Hold the opening of the blower as close to the ground as possible.
- Observe your surroundings. If anyone approaches your work area, set the throttle control to the lowest throttle until the person is at a safe distance. Direct the blower away from people, animals, play areas, and cars etc.
- Clean up afterwards. Make sure that you have not blown rubbish into someone's garden.

1. Do not allow bystanders or animals to be in the work area, i.e. 10 metres from the operator.
2. The powerful air flow can move objects at such speed that they can rebound and cause serious eye injuries.
3. Never point the blower nozzle toward people or animals.
4. Stop the engine before fitting or dismantling accessories or other components.

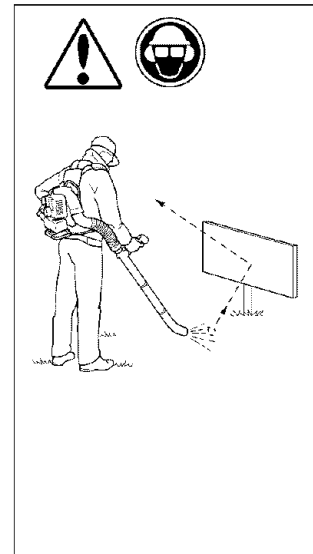

# SAFETY INSTRUCTIONS

5. Never operate the blower in poorly ventilated spaces where exhaust fumes might otherwise be inhaled.
6. Do not operate the blower while standing on a ladder or a stand.
7. Avoid usage in unfavourable weather conditions. For example, thick fog, heavy rain, strong winds or extreme cold, etc. To work in bad weather conditions is tiring and can create dangerous circumstances, e.g. slippery surfaces.
8. Make sure you can walk and stand safely. Look out for any obstacles with unexpected movement (roots, stones, branches, pits, ditches, etc.). Take great care when working on sloping ground.
9. Never put the machine down with the engine running unless you have good sight of it.



## Basic working techniques

- Adjust the harness so that the machine is easy to carry.



**WARNING!**  
Always stop the engine when cleaning.

- The speed of the air jet is controlled with the throttle. Select the speed that best suits the application. To avoid holding your finger on the throttle all the time when using the blower, the required throttle can be set with the throttle adjuster (D). Full throttle is obtained when the throttle adjuster is pushed in fully.
- Make sure that the air intake is not blocked by leaves or rubbish. This will reduce the machine's air blowing capacity and increase the engine's working temperature, which can lead to engine failure. Stop the engine and remove the object.
- Observe the direction of the wind. Work in the direction of the wind to simplify your work.
- Using the blower to move large heaps is time consuming and creates unnecessary noise.

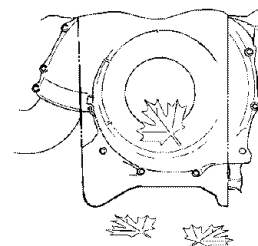
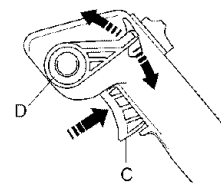

**WARNING!**  
Warning for thrown objects. Always wear protective glasses. Stones, rubbish, etc. can be thrown up into the eyes causing blindness or serious injury. Keep unauthorised persons at a distance. Children, animals, onlookers and helpers should be kept outside the safety zone of 10 m (33 feet). Stop the machine immediately if anyone approaches.

## WHAT IS WHAT?

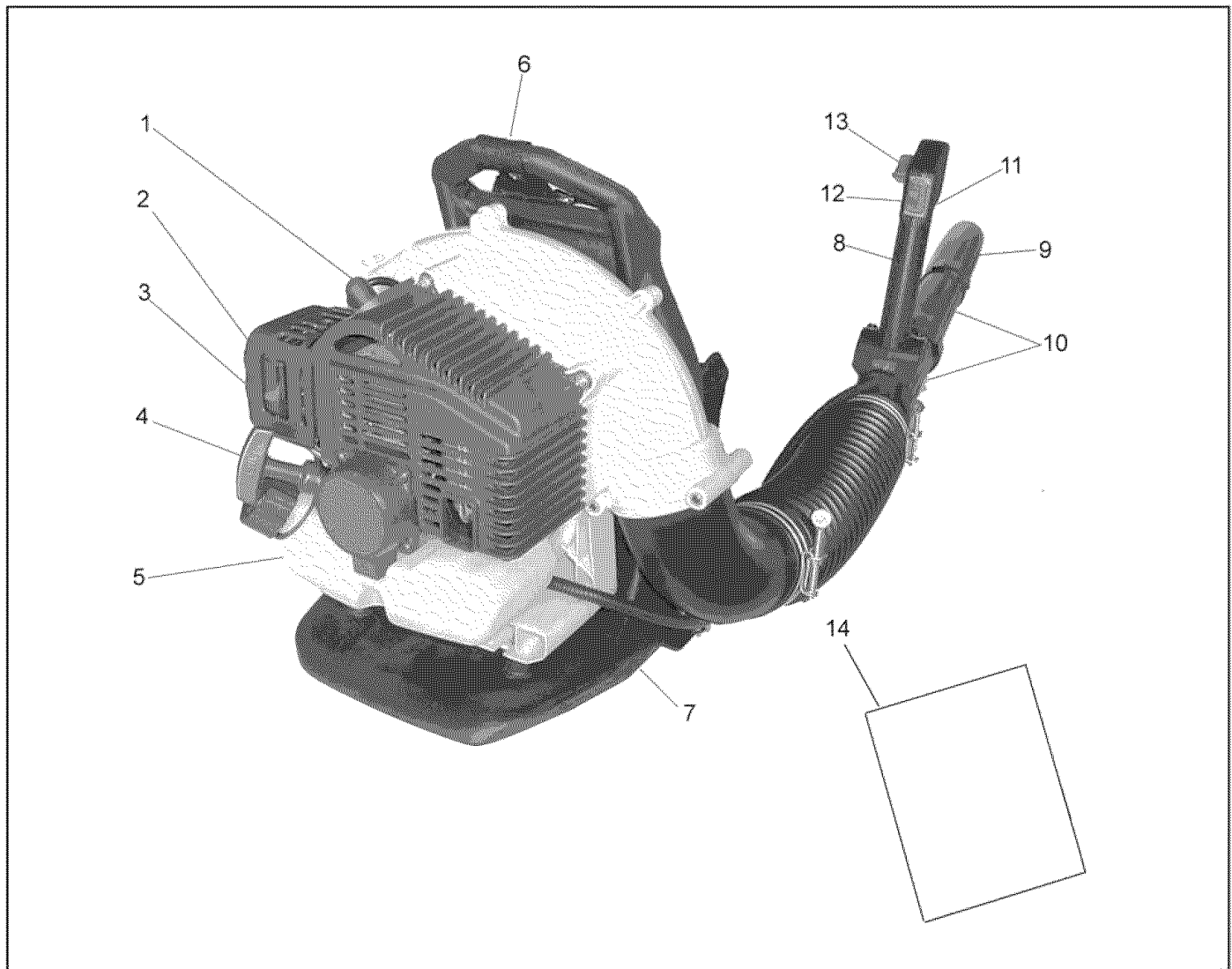

### What is what on the blower?

1. Spark plug
2. Choke
3. Air filter
4. Starter handle
5. Fuel tank
6. Harness
7. Muffler
8. Handle
9. Nozzle
10. Blow tube
11. Throttle control
12. Stop switch
13. Throttle adjuster
14. Operator's Manual

# ASSEMBLY

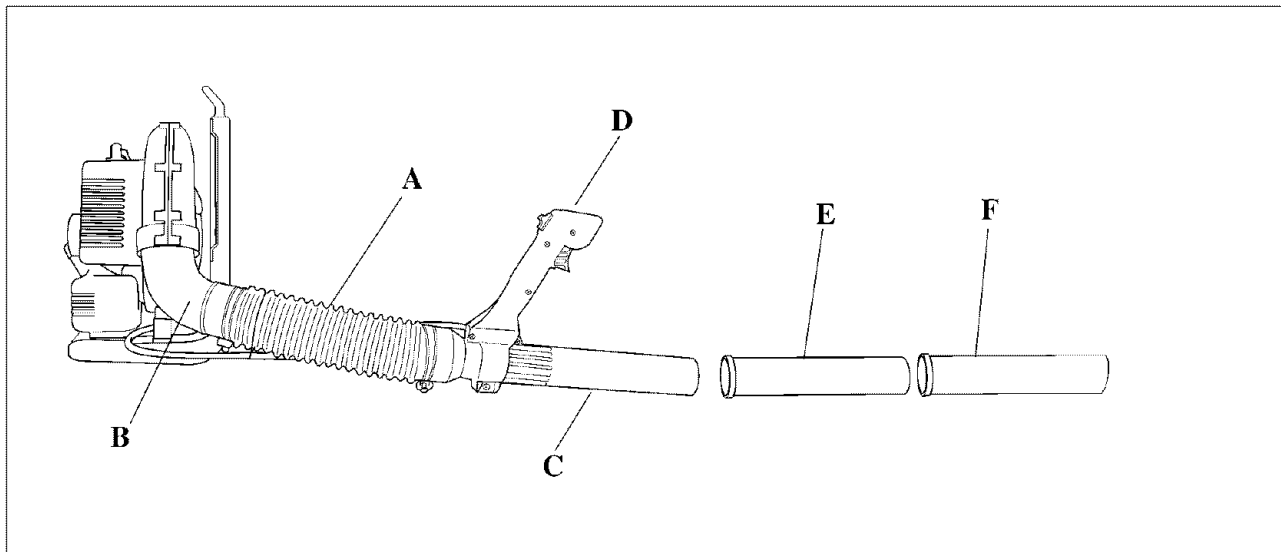

## Assembly of the blower

1. Connect the flexible hose (A) to the fan's outlet tube (B) with a hose clamp.
2. Connect the operating tube (C) to the flexible hose with a hose clamp.
3. Fit the control handle (D) on the operating tube (C).
4. Connect the intermediate tube (E) and air nozzle (F). Push the tubes together and turn them so that they lock together.

### NOTE!

The operating tube can be turned round its axis to direct the air jet.

# FUEL HANDLING

## Fuel mixture

### NOTE!

The machine is fitted with a two-stroke engine and must always be run on a mixture of petrol and two-stroke oil. It is important to measure the quantity of oil accurately, to ensure the correct mixture ratio. Small discrepancies in the amount of oil have a great bearing on the proportions of the fuel mixture when mixing small amounts of fuel.



**WARNING!**  
Always provide good ventilation when handling fuel.

## Petrol

### NOTE!

Always use an oil-mixed quality petrol (at least 90 octane). If your machine is equipped with a catalytic converter, (see "technical data") an unleaded, oil mixed quality petrol should always be used. A leaded petrol will destroy the catalytic converter

- The lowest recommended octane rating is 90. If you run the engine on a petrol with a lower octane rating than 90 so-called "knocking" can occur. This leads to an increased engine temperature, which can result in a serious engine breakdown.
- When working at continuous high revs a higher octane rating is recommended.

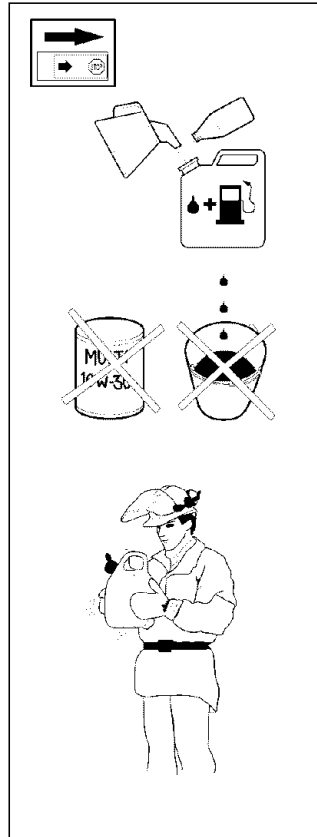

## Two-stroke oil

- For the best results use two-stroke oil, which has been specially produced for clearing saws and chain saws. Mixing ratio 1:50 (2%). **ISO-L-EGD (ISO/CD 13738)**
- Never use two-stroke oil intended for water cooled outboard motors, so-called outboard motor oil.
- Never use oil intended for four-stroke engines.

## Mixture

- Always mix petrol and oil in a clean container intended for petrol.
- Always start by filling half the quantity of petrol required. Then add the entire oil quantity. Mix (shake) the fuel mixture. Fill the remaining quantity of petrol.
- Mix (shake) the fuel mixture carefully before filling in the machine's fuel tank.
- Do not mix more than max. one month's supply of fuel.
- If the machine is not used for a long period of time, the fuel tank should be emptied and cleaned.



**WARNING!**  
The catalytic converter muffler gets very hot during and after use. This also applies during idling. Be aware of the fire hazard, especially when handling the saw near flammable substances or vapours.

## Fuelling



**WARNING!**  
The following precautions reduce the risk of fire:  
Do not smoke or place any sources of heat in the vicinity of the fuel. Never refuel when the engine is running. Always stop the engine and let it cool for a few minutes before refuelling. Open the fuel cap slowly when fuelling so that any over pressure is released slowly. Tighten the fuel cap carefully after refuelling. Always move the machine from the fuelling place before starting.

- Clean around the fuel cap. Contamination in the tank can disrupt operations.
- Ensure that the fuel is well mixed by shaking the container before filling the tank.

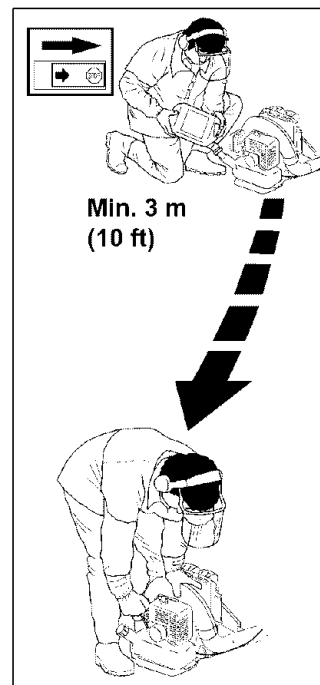

Gasolin Benzin Essence Gasolina Lit.	Oil • Öl Huile • Acete Lit.	2% (1:50)	3% (1:33)
5		0,10	0,15
10		0,20	0,30
15		0,30	0,45
20		0,40	0,60
US gallon	US f. oz.	2% (1:50)	3% (1:33)
1		2 1/2	3 3/4
2 1/2		6 1/2	9 3/4
5		12 7/8	19 1/4

# START AND STOP

## Start and stop



**WARNING!**  
Always move the machine from the filling area before starting. Place the machine on a flat surface. Make sure no unauthorised persons are in the working area, otherwise there is a risk of serious personal injury. The safety distance is 10 metres.

### Cold engine

#### IGNITION:

Set the stop switch to the start position.

#### CHOKE:

Set the choke control in the choke position.

#### AIR PURGE:

Press the air purge diaphragm repeatedly until fuel begins to fill the diaphragm. The diaphragm need not be completely filled.

### Warm engine

Use the same starting procedure as for the cold engine, but do not set the choke control in the choke position. The start throttle position is obtained by setting the choke control in the choke position and then returning it to its original position.

### Stop

The engine is stopped by switching off the ignition.

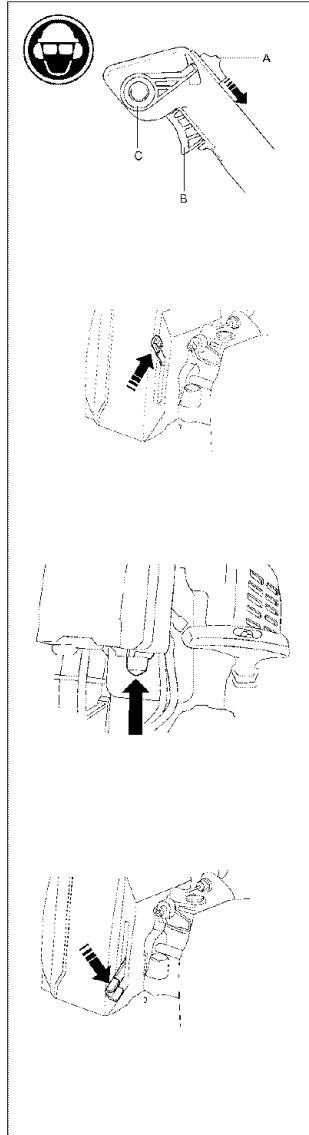

### Start

Press the machine body against the ground using your left hand (NOTE! Not your foot). Grip the starter handle, slowly pull out the cord with your right hand until you feel some resistance (the starter pawls grip), now quickly and powerfully pull the cord. Reset the choke control as soon as the engine fires and repeat until the engine starts. When the engine starts quickly apply full throttle and the start throttle will automatically disengage. NOTE! Do not pull the starter cord out completely and do not release the starter cord from the fully extended position. This can damage the machine.

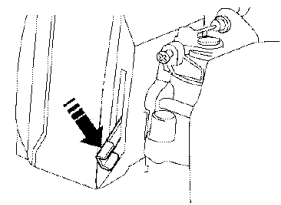
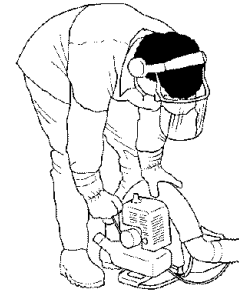



# MAINTENANCE

## Carburettor

Your product has been designed and manufactured to specifications that reduce harmful emissions.

After your unit has been run 8-10 tanks of fuel the engine has broken in. To ensure that your unit is at peak performance and producing the least amount of harmful emissions after break in, have your authorized servicing dealer, who has a revolution counter at his disposal, to adjust your carburettor for optimum operating conditions.



### WARNING!

The machine must only be started as a complete unit. If the machine is started without all the covers fitted there is a risk of personal injury.

## Operation

- The carburettor governs the engine's speed via the throttle. Air/fuel is mixed in the carburettor. The air/fuel mixture is adjustable. To take advantage of the engine's optimal output the adjustment must be correct.
- The setting of the carburettor means that the engine is adapted to local conditions, for example, the climate, altitude, petrol and the type of 2-stroke oil.

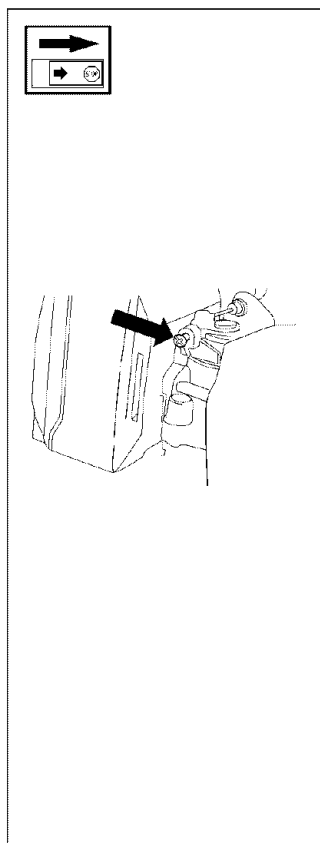

## Basic setting

- The carburettor is set to its basic setting when test run at the factory. The basic setting is richer than the optimal setting and should be kept during the machine's first working hours. Thereafter the carburettor should be finely adjusted. Fine adjustment should be carried out by a skilled technician.

## Fine adjustment

- When the machine has been "run-in" the carburettor should be finely adjusted. The fine adjustment should be carried out by qualified person. First adjust the L-jet, then the idling screw T and then the H-jet.

## Conditions

- Before any adjustments are made the airfilter should be clean and the airfilter cover fitted. Adjusting the carburettor while a dirty airfilter is in use will result in a leaner mixture when the filter is finally cleaned. This can give rise to serious engine damage.

## Muffler

### NOTE!

Some mufflers are fitted with a catalytic converter. See "Technical data" to see whether your machine is fitted with a catalytic converter.

The muffler is designed to dampen the noise level and to direct the exhaust fumes away from the user. The exhaust fumes are hot and can contain sparks, which can result in fire if the exhaust fumes are directed towards a dry and inflammable material. Some mufflers are equipped with a special spark arrest screen. If your machine is fitted with this type of screen it should be cleaned regularly. This is done using a wire brush. On mufflers without a catalytic converter the screen should be cleaned weekly, or replaced if necessary. On mufflers fitted with a catalytic converter the screen should be checked and cleaned monthly. **If the screen is damaged it should be replaced.** If the screen is frequently blocked, this can be a sign that the function of the catalytic converter is impaired. Contact your dealer to inspect the muffler. A blocked screen will cause the engine to overheat resulting in damage to the cylinder and piston. Also see under "Maintenance".

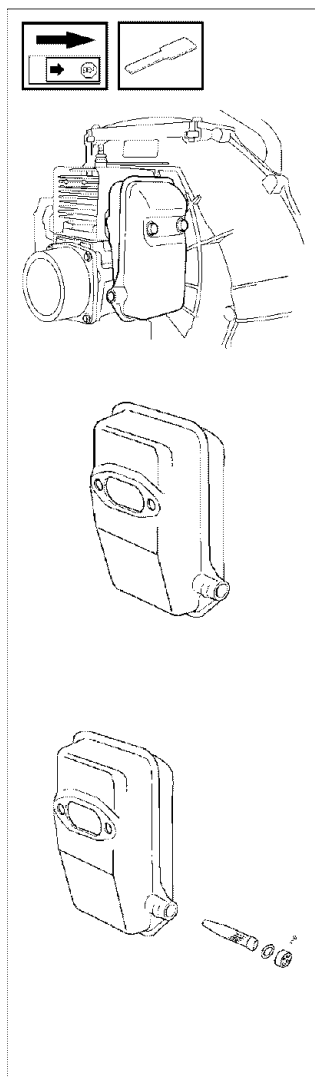

### NOTE!

Never use a machine with a defective muffler.

## Cooling system

To maintain as low operating temperature as possible the engine is equipped with a cooling system.

The cooling system consists of:

1. An air intake on the starter unit.
2. Cooling fins on the flywheel.
3. Cooling fins on the cylinder
4. Cylinder cover (leads cold air onto the cylinder).

Clean the cooling system using a brush at least once a week, in difficult conditions more often.

**A dirty or blocked cooling system leads to the engine overheating resulting in damage to the cylinder and piston.**

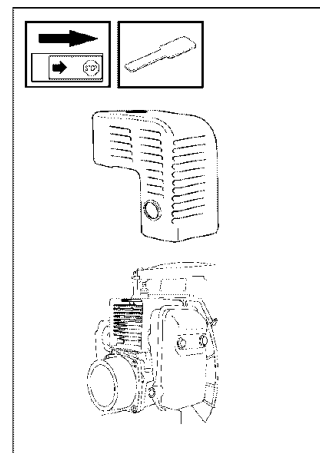

## Spark plug

The condition of the spark plug is affected by:

- An incorrect carburettor setting.
- An incorrect fuel mixture (too much or faulty oil).
- A dirty air filter.

These factors cause deposits on the spark plug electrode that may result in malfunction or starting difficulties.

**If the machine is low on power, difficult to start or runs poorly while idling always check the spark plug first.**

If the spark plug is dirty, clean it and at the same time check that the electrode gap is 0.5 mm. The spark plug should be changed after about one month of operation or earlier if necessary.

**NOTE!** Always use the recommended type of spark plug. An incorrect spark plug can damage the cylinder/piston.

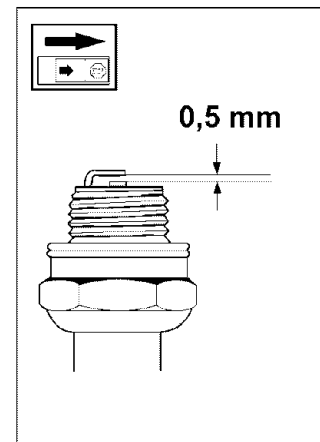

## Air filter

The air filter should be cleaned regularly removing dust and dirt to avoid:

- carburettor malfunction
- starting problems
- reduced engine power
- unnecessary wear to engine parts
- abnormal fuel consumption

Clean the filter after every 25 hours or more regularly if operating conditions are exceptionally dusty.

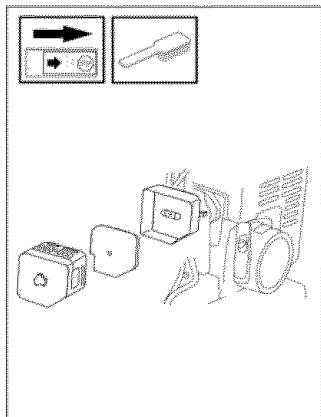

### Cleaning the air filter

Dismantle the air filter cover and remove the air filter. Wash in clean, warm soapy water. Ensure that the filter is dry before refitting. An air filter used for a long period of time can never be cleaned completely. Therefore it is necessary to replace the filter from time to time with a new filter. A damaged air filter must always be replaced.

If the machine is used in dusty conditions the air filter should be soaked in oil, see the section on "*Oiling the air filter*".

### Oiling the air filter

The filter oil contains a solvent to make it spread evenly through the filter. You should therefore avoid skin contact. Put the filter in a plastic bag and then pour the filter oil over it.

Knead the plastic bag to distribute the oil. Squeeze the excess oil out of the filter inside the plastic bag and pour off the excess before

fitting the filter on the machine. Never use common engine oil. This would drain through the filter quite quickly and collect in the bottom.

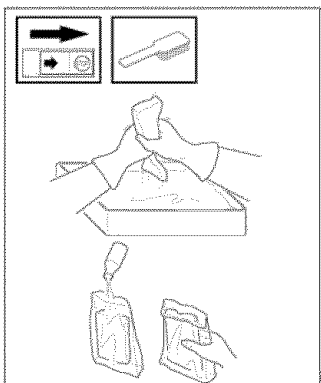

## Maintenance schedule

Below follows some general maintenance instructions. If you need further information please contact your service workshop.

### Daily maintenance

1. Clean the outside of the machine.
2. Check that the throttle control functions safely.
3. Check that the stop switch functions.
4. Clean the air filter. Replace if necessary.
5. Check that all nuts and screws are tightened.

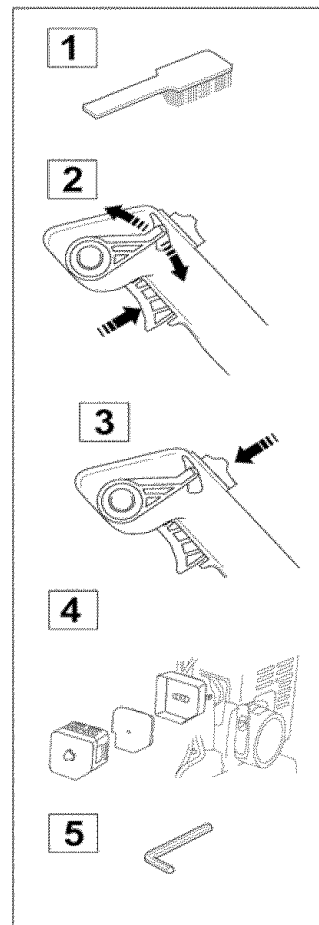

# MAINTENANCE

## Weekly maintenance

1. Check the starter, the starter cord and the return spring.
2. Make sure that the vibration damping elements are not damaged.
3. Clean the outside of the spark plug. Remove and check the electrode gap. Adjust the gap to 0.5 mm or change the spark plug.
4. Clean the cooling fins on the flywheel.
5. Clean or replace the muffler's spark arrest screen (not on mufflers with a catalytic converter).
6. Clean the carburettor area.
7. Clean the cooling fins on the cylinder and check that the air intake in the starter unit is not blocked.

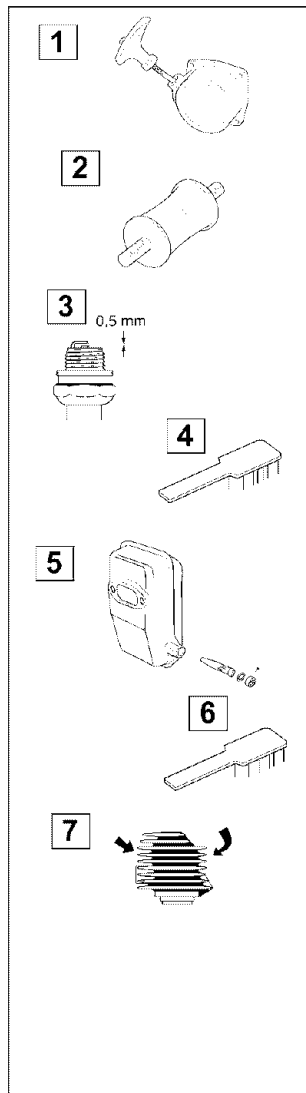

## Monthly maintenance

1. Clean the fuel tank.
2. Clean the carburettor and the area surrounding it.
3. Clean the fan and the area around it.
4. Check the fuel filter and the fuel pipe, replace if necessary.
5. Check all cables and connections.
6. Change the spark plug.
7. Check and clean the muffler's spark arrest screen if necessary (only mufflers with a catalytic converter).

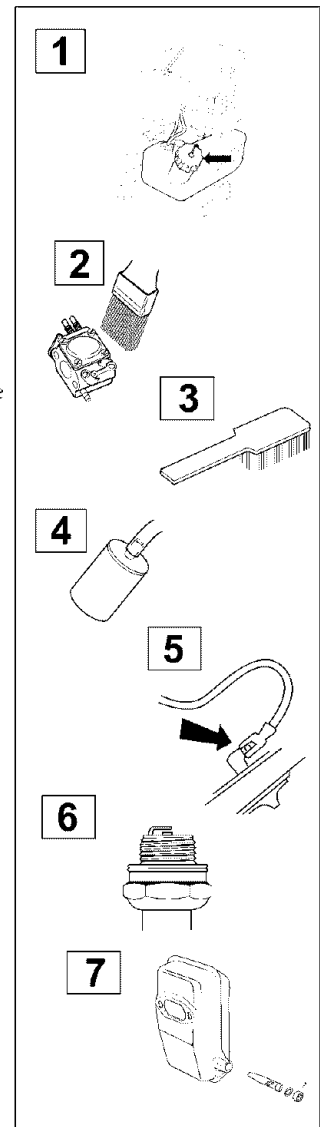

---

# TECHNICAL DATA

---

## Technical data

## 125BT

### Engine

Cylinder capacity, cm <sup>3</sup>	25,4
Cylinder bore, mm	34
Stroke length, mm	28
Idling speed, rpm	3 300
Recommended max. speed, rpm	7 800
Max. engine output, acc. to ISO 8893	0,7kW/7000rpm/min
Catalytic converter muffler	No

### Ignition system

Manufacturer/type of ignition system	ET
Spark plug	NGK BPMR6A
Electrode gap, mm	0,5mm

### Fuel lubrication system

Manufacturer/type of carburettor	Walbro,membran
Fuel tank capacity, litres	0,5

### Weight

Weight without fuel, cutting tool and guard kg	5,0
--	-----

### Vibration levels

Vibration levels on the handles, measured according to EN 31806 and ISO 7916, m/s<sup>2</sup>

When idling, handles, max:	1,2
At max. speed, handles, max:	1,2

