

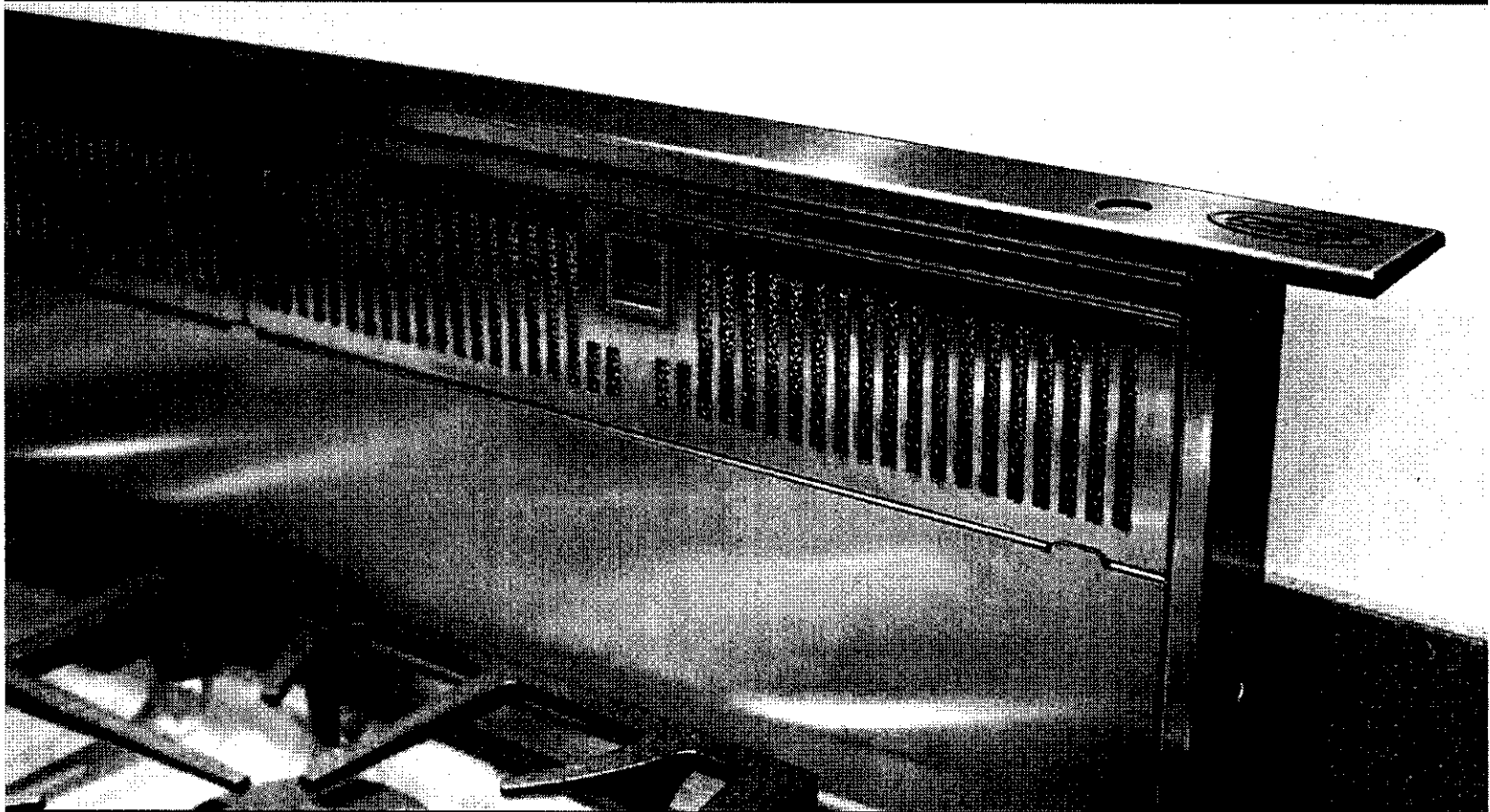

THE PROFESSIONAL DOWNDRAFT

Use and Care Guide



MODELS:
DD-36SS
DD-30SS



A MESSAGE TO OUR CUSTOMERS

Thank you for selecting this DCS Downdraft Vent System. Because of its unique features, we have developed this Use and Care Guide. It contains valuable information on how to properly operate and maintain your new Downdraft Vent System for years of safe and enjoyable service.

To help serve you better, please fill out and return the Ownership Registration Card and keep this guide handy, as it will help answer questions that may arise as you use your Downdraft Vent System.

For your convenience, product questions can be answered by a DCS Customer Care Representative by phone: 1-888-281-5698, email: support@dcsappliances.com

or by mail:
Fisher & Paykel Appliances, Inc.
Attention: DCS Customer Care
5900 Skylab Road
Huntington Beach, CA 92647

www.dcsappliances.com

WARNING

TO REDUCE THE RISK OF A COOK TOP GREASE FIRE:

Never leave surface units unattended at high settings. Boilovers cause smoking and greasy spillovers that may ignite. Heat oils slowly on low or medium setting. Always turn the Downdraft "ON" when cooking at high heat or when cooking flaming foods. Clean ventilating fans frequently. Grease should not be allowed to accumulate on fan or filter. Use proper pan size. Always use cookware appropriate for the size of the surface element.

WARNING

TO REDUCE THE RISK OF INJURY TO PERSONS IN THE EVENT OF A COOKTOP GREASE FIRE, OBSERVE THE FOLLOWING: SMOTHER FLAMES with a close-fitting lid, cookie sheet, or metal tray, then turn off the burner. **BE CAREFUL TO PREVENT BURNS.** If the flames do not go out immediately **EVACUATE AND CALL THE FIRE DEPARTMENT. NEVER PICK UP A FLAMING PAN** - You may be burned. **DO NOT USE WATER**, including wet dishcloths or towels - a violent steam explosion will result. Use an extinguisher **ONLY** if:

1. You know you have a Class ABC extinguisher, and you already know how to operate it.
2. The fire is small and contained in the area where it started.
3. The fire department is being called.
4. You can fight the fire with your back to an exit.

PLEASE RETAIN THIS MANUAL FOR FUTURE REFERENCE.

TABLE OF CONTENTS

SAFETY PRACTICES & PRECAUTIONS	3
USE AND CARE	4
WIRING DIAGRAM	5
HOW TO OBTAIN SERVICE	6
WARRANTY	7-8

SAFETY PRACTICES & PRECAUTIONS



WARNING:

ALL WALL AND FLOOR OPENINGS WHERE THE Downdraft IS INSTALLED MUST BE SEALED.

Consult the cooktop or range installation instructions given by the manufacturer before making any cutouts. **MOBILE HOME INSTALLATION** - The installation of this Downdraft must conform to the Manufactured Home Construction and Safety Standards, Title 24 CFR, Part 3280 (formerly Federal Standard for Mobile Home Construction and Safety, Title 24, HUD, Part 280). Three wire power supply must be used and the appliance wiring must be revised. See Electrical Requirements.

- Venting system **MUST** terminate outside the home.
- **DO NOT** terminate the ductwork in an attic or other enclosed space.
- **DO NOT** use 4" laundry-type wall caps.
- Flexible-type ductwork is not recommended.
- **DO NOT** obstruct the flow of combustion and ventilation air.
- Failure to follow venting requirements may result in a fire.
- Electrical ground is required on this Downdraft system.
- If cold water pipe is interrupted by plastic, non-metallic gaskets or other materials, **DO NOT** use for grounding.
- **DO NOT** ground to a gas pipe.
- **DO NOT** have a fuse in the neutral or grounding circuit. A fuse in the neutral or grounding circuit could result in electrical shock.
- Check with a qualified electrician if you are in doubt as to whether the downdraft is properly grounded.
- Failure to follow electrical requirements may result in a fire.



WARNING:

TO REDUCE THE RISK OF FIRE, ELECTRICAL SHOCK, OR INJURY TO PERSONS, OBSERVE THE FOLLOWING:

Use this unit only in the manner intended by the manufacturer. If you have any questions, contact the manufacturer. Before servicing or cleaning unit, switch power off at service panel and lock the service disconnecting means to prevent power from being switched on accidentally. When the service disconnecting means cannot be locked, securely fasten a prominent warning device, such as a tag, to the service panel. Installation Work And Electrical Wiring Must Be Done By Qualified Person(s) In Accordance With All Applicable Codes And Standards, Including Fire-Rated Construction. Sufficient air is needed for proper combustion and exhausting of gases from fuel burning equipment through the flue (chimney) to prevent backdrafting. Follow the heating equipment manufacturer's guideline and safety standards such as those published by the National Fire Protection Association (NFPA), and the American Society for Heating, Refrigeration and Air Conditioning Engineers (ASHRAE), and the local code authorities. When cutting or drilling into wall or ceiling, do not damage electrical wiring and other hidden utilities. Ducted fans must always be vented to the outdoors.

USE & CARE INFORMATION

This vent system is designed to remove smoke, cooking vapors and odors from the cooktop area. This unit also has several features to insure operator safety.

TO OPERATE THE DOWNDRAFT

Push the Up/Down button on top of the Downdraft to raise the plenum as indicated. The speed control knob is located on the right hand side of the plenum. Press the Up/Down button to lower the unit. The Up/Down button must be pressed and held momentarily to raise or lower the plenum. This is a safety feature which protects against accidental activation when cleaning the plenum. For best results, start the Downdraft before cooking and allow the unit to operate for several minutes after cooking is complete to clear all smoke and odors from the kitchen. If using large pots, place them on the rear burner to insure proper ventilation. A higher fan setting may be required.

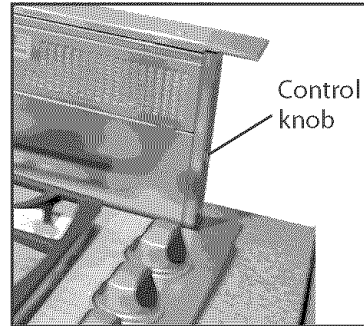

CLEANING

The metal grease filters should be cleaned frequently in hot detergent solution or washed in the dishwasher. The plenum and top strip should be cleaned with stainless steel cleaner. Abrasives and scouring agents can scratch stainless steel finishes and should not be used.

USE WITH GAS COOKTOPS

The DCS Downdraft Vent System is designed for safe use with gas cooktops and will not extinguish burners or pilots. The blower does not start operation until the plenum has reached the full upright position. Also, the blower stops operation as soon as the Up/Down switch is pressed to lower the unit.



WARNING:

If a spill occurs on the cooktop that allows liquids to seep inside the Downdraft, you must turn the Downdraft off immediately. It is possible to cause damage to the Downdraft if water is allowed inside the Downdraft while it is operating.

- Immediately turn "OFF" the Downdraft at the speed control located on the right hand side of the Downdraft.
- Turn "OFF" the power supply to the Downdraft at the circuit breaker box or fuse box.
- Allow plenty of time for the Downdraft to dry naturally. Do not open the Downdraft to remove the water. Failure to follow these warnings could result in damage to the Downdraft.

SAFETY MICROSWITCHES

This Downdraft Vent System is designed with a safety microswitch behind the center of each grease filter. These microswitches prevent the blower and plenum-raising mechanism from operating when either of the grease filters is removed. It is very important to make sure that the grease filters are properly and firmly in place after cleaning. If the unit does not operate after replacing the grease filters, make sure the filters are properly installed and are making firm contact with the safety microswitches.

WIRING DIAGRAM

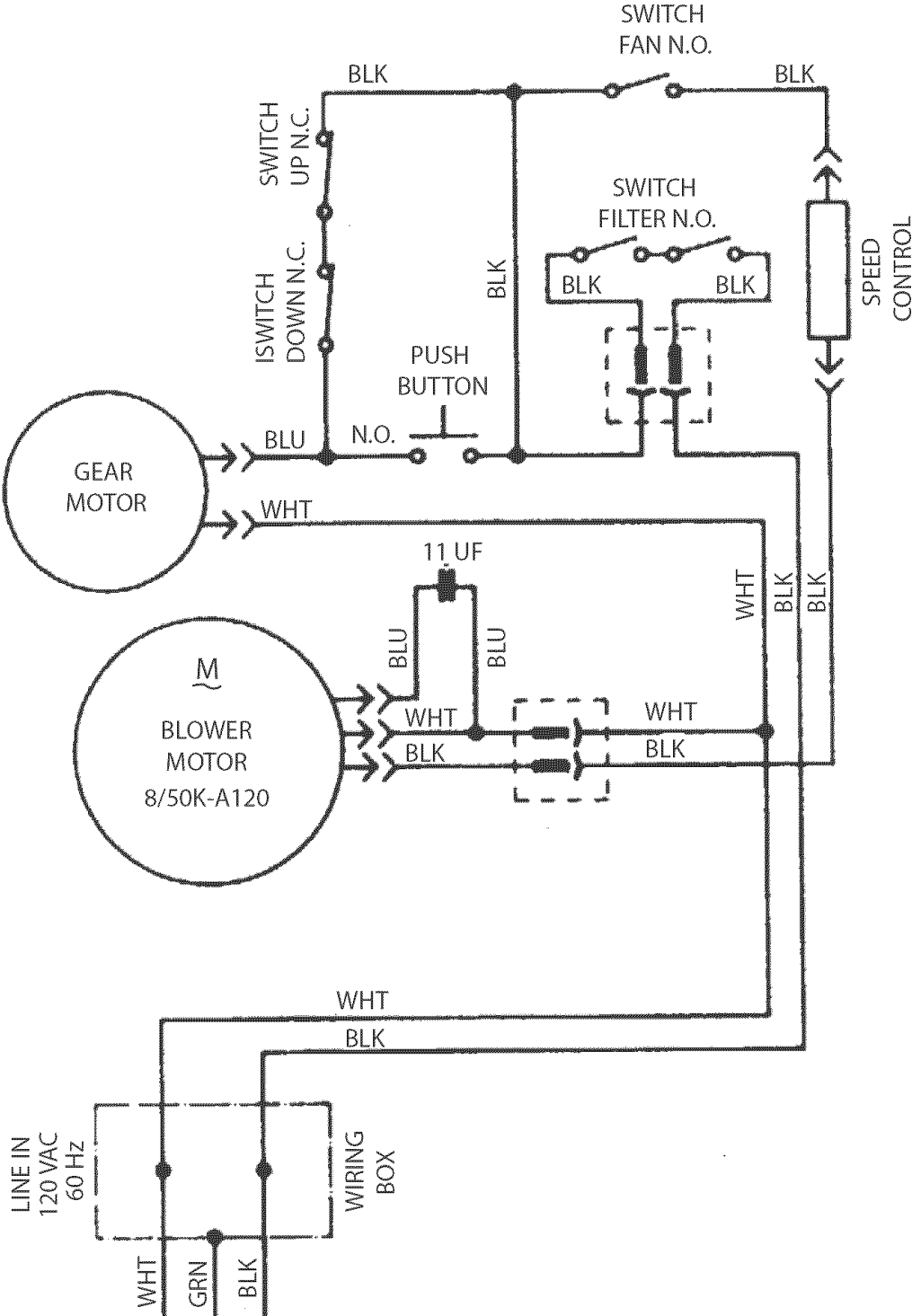

HOW TO OBTAIN SERVICE:

Before you call for service:

- 1) Is the circuit breaker tripped or the fuse blown?
- 2) Is there a power outage in the area?
- 3) Are the grease filters properly installed?
- 4) Will the unit go up/down and the blow control is on?

For warranty service, contact DCS Customer Care at (888) 281-5698. Before you call, please have the following information ready:

- Model Number
- Serial Number
- Date of installation
- A brief description of the problem

Your satisfaction is of the utmost importance to us. If a problem cannot be resolved to your satisfaction, please write at:

Write:
Fisher & Paykel Appliances, Inc.
Attention: DCS Customer Care
5900 Skylab Road
Huntington Beach, CA 92647

WARRANTY

LIMITED WARRANTY

When you purchase a new DCS Ventilation Product for personal or consumer use you automatically receive a One year Limited Warranty covering parts and labor for the entire product, and a Five year Limited Warranty on the switches and motor (parts only) for servicing within the 48 mainland United States, Hawaii, Washington D.C and Canada. In Alaska the Limited Warranty is the same except that you must pay to ship the Product to the service shop or for the service technician's travel to your home. Products for use in Canada must be purchased through the Canadian distribution channel to ensure regulatory compliance.

If the Product is installed in a motor vehicle, boat or similar mobile facility, you receive the same One year Limited Warranty, but you must bring the vehicle, boat or mobile facility containing the Product to the service shop at your expense or pay the service technician's travel to the location of the Product.

FISHER & PAYKEL UNDERTAKES TO:

Repair without cost to the owner either for material or labor any part of the Product, the serial number of which appears on the Product, which is found to be defective. In Alaska, you must pay to ship the Product to the service shop or for the service technician's travel to your home. If the Product is installed in a motor vehicle, boat or similar mobile facility, you must bring it to the service shop at your expense or pay for the service technician's travel to the location of the Product. If we are unable to repair a defective part of the Product after a reasonable number of attempts, at our option we may replace the part or the Product, or we may provide you a full refund of the purchase price of the Product (not including installation or other charges).

This warranty extends to the original purchaser and any succeeding owner of the Product for products purchased for ordinary single-family home use. All service under this Limited Warranty shall be provided by Fisher & Paykel or its Authorized DCS Service Agent during normal business hours.

HOW LONG DOES THIS LIMITED WARRANTY LAST?

Our liability under this Limited Warranty for the entire product expires ONE YEAR from the date of purchase of the Product by the first consumer. Our liability under this Limited Warranty for the switches and motor (parts only) expires FIVE YEARS from the date of purchase of the Product by the first consumer.

Our liability under any implied warranties, including the implied warranty of merchantability (an unwritten warranty that the Product is fit for ordinary use) also expires ONE YEAR (or such longer period as required by applicable law) from the date of purchase of the Product by the first consumer. Some states do not allow limitations on how long an implied warranty lasts, so this limit on implied warranties may not apply to you.

THIS WARRANTY DOES NOT COVER:

- A. Service calls that are not related to any defect in the Product. The cost of a service call will be charged if the problem is not found to be a defect of the Product. For example:
1. Correct faulty installation of the Product.
 2. Instruct you how to use the Product.
 3. Replace house fuses, reset circuit breakers, correct house wiring or plumbing, or replace light bulbs.
 4. Correct fault(s) caused by the user.
 5. Change the set-up of the Product.
 6. Unauthorized modifications of the Product.

WARRANTY

7. Noise or vibration that is considered normal, for example, drain/fan sounds, regeneration noises or user warning beeps.
 8. Correcting damage caused by pests, for example, rats, cockroaches etc.
- B. Defects caused by factors other than:
1. Normal domestic use or
 2. Use in accordance with the Product's User Guide.
- C. Defects to the Product caused by accident, neglect, misuse, fire, flood or Act of God.
- D. The cost of repairs carried out by non-authorized repairers or the cost of correcting such unauthorized repairs.
- E. Travel Fees and associated charges incurred when the product is installed in a location with limited or restricted access. (i.e. airplane flights, ferry charges, isolated geographic areas).
- F. Normal recommended maintenance as set forth in the Product's User Guide.

If you have an installation problem contact your dealer or installer. You are responsible for providing adequate electrical, exhausting and other connection facilities. We are not responsible for consequential or incidental damages (the cost of repairing or replacing other property damaged if the Product is defective or any of your expenses caused if the Product is defective). Some states do not allow the exclusion or limitation of incidental or consequential damages, so the above limitation or exclusion may not apply to you.

HOW TO GET SERVICE

Please read your User Guide. If you then have any questions about operating the Product, need the name of your local DCS Authorized Service Agent, or believe the Product is defective and wish service under this Limited Warranty, please contact your dealer or call us at:

TOLL FREE 1-888-281 5698 or contact us through our web site: www.dcsappliances.com.

You may be required to provide reasonable proof of the date of purchase of the Product before the Product will be serviced under this Limited Warranty.

COMMERCIAL USE

This warranty applies to appliances used in residential applications; it does not cover their use in commercial situations.

NO OTHER WARRANTIES

This Limited Warranty is the complete and exclusive agreement between you and Fisher & Paykel regarding any defect in the Product. None of our employees (or our Authorized Service Agents) are authorised to make any addition or modification to this Limited Warranty.

Warrantor: Fisher & Paykel Appliances, Inc.

If you need further help concerning this Limited Warranty, please call us at the above number, or write to:

Fisher & Paykel Appliances, Inc.
5900 Skylab Road, Huntington Beach, CA 92647

This Limited Warranty gives you specific legal rights, and you may also have other rights which vary from state to state.



A Fisher & Paykel Appliances, Inc. Company

Fisher & Paykel Appliances, Inc.
5900 Skylab Road, Huntington Beach, CA 92647
Customer Care: 888.281.5698
Fax: 714.372.7003
www.dcsappliances.com

As product improvement is an ongoing process at DCS, we reserve the right to change specifications or design without notice.

DCS améliore constamment ses produits et se réserve le droit de modifier les spécifications ou la conception de ses produits sans aucun préavis.

Part No. 17385 Rev. C
Litho in USA 02/2005