

**Refrigerator**  
Use & Care Guide

**Refrigerador**  
Guía para su uso y cuidado

**Réfrigérateur**  
Guide d'utilisation et d'entretien

44723



Sears, Roebuck and Co., Hoffman Estates, IL 60179 U.S.A.  
Sears Canada, Inc., Toronto, Ontario, Canada M5B 2B8

www.sears.com  
297055500 (0508)

ENGLISH

ESPAÑOL

FRANÇAIS

## TABLE OF CONTENTS

Serial/Model Numbers .....	2
Important Safety Instructions .....	2-3
Refrigerator Warranty .....	3
Protection Agreements .....	4
Features at a Glance .....	4
First Steps .....	5-6
Setting the Temperature Control .....	6
Refrigerator Features .....	6-7
Food Storage & Energy Saving Tips .....	7
Care and Cleaning .....	8
Before You Call .....	9-10

## SERIAL / MODEL NUMBERS

### READ AND SAVE THESE INSTRUCTIONS

This Owner's Guide provides specific operating instructions for your model. Use your refrigerator only as instructed in this guide. These instructions are not meant to cover every possible condition and situation that may occur. Common sense and caution must be practiced when installing, operating, and maintaining any appliance.

### RECORD YOUR MODEL AND SERIAL NUMBERS

Record the model and serial numbers in the space provided below. The serial plate is located on the left wall inside the refrigerator.

Model Number: 253.  
or 970.  
Serial Number: \_\_\_\_\_  
Purchase Date: \_\_\_\_\_

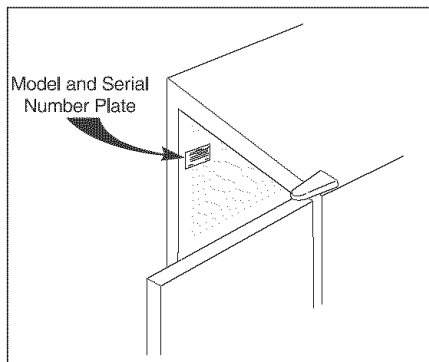

## IMPORTANT SAFETY INSTRUCTIONS

**READ ALL INSTRUCTIONS BEFORE USING THIS REFRIGERATOR.**

### **WARNING**

#### FOR YOUR SAFETY

Do not store or use gasoline, or other flammable vapors and liquids in the vicinity of this or any other appliance. Read product labels for flammability and other warnings.

#### CHILD SAFETY

- Destroy carton, plastic bags, and any exterior wrapping material immediately after the freezer is unpacked. Children should never use these items to play. Cartons covered with rugs, bedspreads, plastic sheets or stretch wrap may become airtight chambers, and can quickly cause suffocation.
- Remove all staples from the carton. Staples can cause severe cuts, and destroy finishes if they come in contact with other appliances or furniture.
- An empty, discarded ice box, refrigerator, or freezer is a very dangerous attraction to children.
- Remove and discard any spacers used to secure the shelves during shipping. Small objects are a choke hazard to children.
- Remove the door(s) of any appliance that is not in use, even if it is being discarded.

### PROPER DISPOSAL OF YOUR REFRIGERATOR/ FREEZER

### **WARNING**

**Risk of child entrapment. Child entrapment and suffocation are not problems of the past. Junked or abandoned refrigerators or freezers are still dangerous — even if they will sit for "just a few days." If you are getting rid of your old refrigerator or freezer, please follow the instructions below to help prevent accidents.**

#### BEFORE YOU THROW AWAY YOUR OLD REFRIGERATOR/FREEZER:

- Remove doors.
- Leave shelves in place so children may not easily climb inside.
- Have refrigerant removed by a qualified service technician.

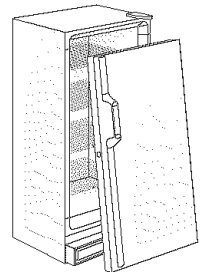

**⚠ WARNING**

**ELECTRICAL INFORMATION**

These guidelines must be followed to ensure that safety mechanisms in the design of this refrigerator will operate properly.

- **Refer to the serial plate for correct electrical rating.** The power cord of the appliance is equipped with a three-prong grounding plug for your protection against shock hazards. It must be plugged directly into a properly grounded three-prong receptacle. The power supply circuit must be installed in accordance with current edition of the National Electrical Code (NFPA 70) and local codes and ordinances. Consult a qualified electrician. Receptacles protected by Ground Fault Circuit Interrupters (GFCI) are NOT RECOMMENDED. **Do not use an extension cord or adapter plug.**
- If voltage varies by 10% or more, refrigerator performance may be affected. Operating refrigerator with insufficient power can damage the motor. Such damage is not covered under the warranty. If you suspect your household voltage is high or low, consult your power company for testing.
- To prevent the refrigerator from being turned off accidentally, do not plug unit into an outlet controlled by a wall switch or pull cord.
- Do not pinch, knot, or bend the cord in any manner.

**OTHER PRECAUTIONS**

- To defrost refrigerator, always unplug unit first.
- Never unplug the refrigerator by pulling on the cord. Always grip the plug firmly, and pull straight out from the receptacle.

**NOTE**

Turning the temperature control to OFF turns off the compressor, but does not disconnect the power to the light bulb or other electrical components.

**⚠ WARNING**

Avoid fire hazard or electric shock. Do not use an extension cord or an adapter plug. Do not remove any prong from the power cord.

Grounding type wall receptacle

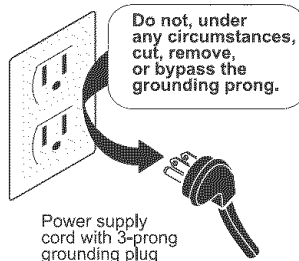

Power supply cord with 3-prong grounding plug

**REFRIGERATOR WARRANTY**

**WARRANTY INFORMATION**

**KENMORE REFRIGERATOR WARRANTY**

**ONE YEAR FULL WARRANTY ON REFRIGERATOR**

For one year from the date of purchase, when this refrigerator is operated and maintained according to the instructions supplied with it, Sears will repair this refrigerator, free of charge, if defective in material or workmanship. This one year time period does not include the refrigerator water filter cartridge (if equipped), which is an expendable part warranted for only 30 days (see below).

**FIVE YEAR FULL WARRANTY ON SEALED REFRIGERATION SYSTEM**

For five years from the date of purchase, when this refrigerator is operated and maintained according to the instructions supplied with it, Sears will repair the sealed system (consisting of refrigerant, connecting tubing, and compressor), free of charge, if defective in material or workmanship.

**30 DAY FULL WARRANTY ON WATER FILTER CARTRIDGE (IF EQUIPPED)**

For thirty days from the date of purchase, Sears will replace the refrigerator water filter cartridge if it is defective in material or workmanship.

All above warranty coverage applies only to refrigerators which are used for storage of food for private household purposes.

Warranty service is available in the United States or Canada by contacting Sears at 1-800-4-MY-HOME® (1-800-469-4663).

This warranty applies only while this product is in use in the United States or Canada. This warranty gives you specific legal rights, and you may also have other rights which vary from state to state or province to province.

**Sears, Roebuck and Co., Dept. 817WA, Hoffman Estates, IL 60179**

**Sears Canada Inc., Toronto, Ontario, Canada M5B 2B8**

**ENGLISH**

# PROTECTION AGREEMENTS

## In the U.S.A.

### Master Protection Agreements

Congratulations on making a smart purchase. Your new Kenmore Elite® product is designed and manufactured for years of dependable operation. But like all products, it may require preventive maintenance or repair from time to time. That's when having a Master Protection Agreement can save you money and aggravation.

*Purchase a Master Protection Agreement now and protect yourself from unexpected hassle and expense.*

The Master Protection Agreement also helps extend the life of your new appliance. Here's what's included in the Agreement:

- ☑ **Expert service** by our 12,000 professional repair specialists
- ☑ **Unlimited service and no charge** for parts and labor on all covered repairs
- ☑ **"No-lemon" guarantee** – replacement of your covered product if four or more product failures occur within twelve months
- ☑ **Product replacement** if your covered product can't be fixed
- ☑ **Annual Preventive Maintenance Check** at your request – no extra charge
- ☑ **Fast help by phone** – phone support from a Sears technician on products requiring in-home repair, plus convenient repair scheduling
- ☑ **Power surge protection** against electrical damage due to power fluctuations
- ☑ **Rental reimbursement** if repair of your covered product takes longer than promised

Once you purchase the Agreement, a simple phone call is all that it takes for you to schedule service. You can call anytime day or night, or schedule a service appointment online.

Sears has over 12,000 professional repair specialists, who have access to over 4.5 million quality parts and accessories. That's the kind of professionalism you can count on to help prolong the life of your new purchase for years to come. Purchase your Master Protection Agreement today!

**Some limitations and exclusions apply. For prices and additional information, call 1-800-827-6655.**

### Sears Installation Service

For Sears professional installation of home appliances and items like garage door openers, water heaters, and other major home items, in the U.S.A. call **1-800-4MY-HOME®**.

## In Canada

### Maintenance Agreements

Your purchase has added value because you can depend on Sears HomeCentral® for service. With over 2400 Service Technicians and more than a million parts and accessories, we have the tools, parts, knowledge and skills to back our pledge:

**We Service What We Sell.**

Your Kenmore Elite® product is designed, manufactured and tested to provide years of dependable operation. But like all products, it may require service from time to time. The Sears Maintenance Agreement offers you an outstanding service program, affordably priced.

### The Sears Maintenance Agreement

- Is your way to buy tomorrow's service at today's price.
- Eliminates repair bills resulting from normal wear and tear.
- Provides phone support from a Sears technician on products requiring in-home repair.
- Even if you don't need repairs, provides an annual Preventive Maintenance Check, at your request, to ensure that your product is in proper running condition.

**Some limitations apply. For more information about concerning Sears Canada Maintenance Agreements, call 1-800-361-6665.**

## FEATURES AT A GLANCE

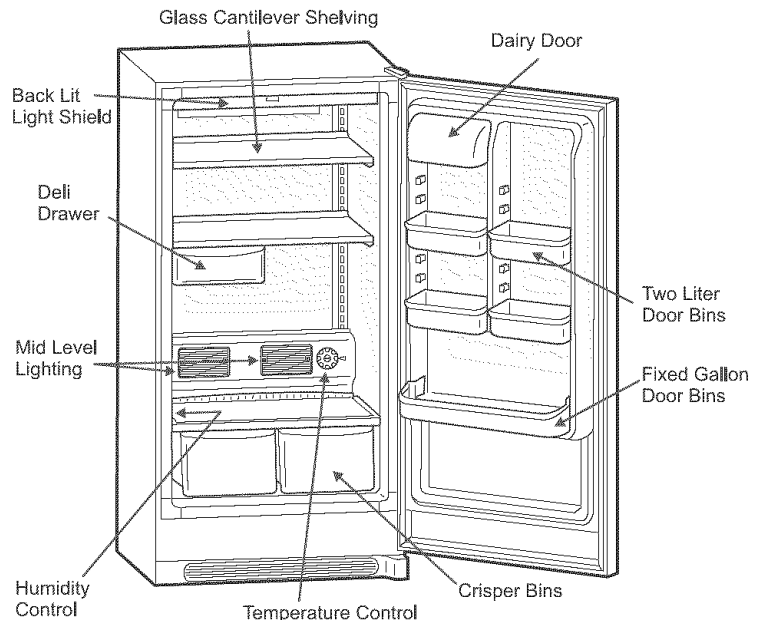

## FIRST STEPS

This Owner's Guide provides specific operating instructions for your model. Use the refrigerator only as instructed in this Owner's Guide. **Before starting the refrigerator, follow these important first steps.**

### INSTALLATION

- Choose a place that is near a grounded electrical outlet. **Do Not** use an extension cord or an adapter plug.
- For the most efficient operation, the refrigerator should be located where surrounding temperatures will not drop below 40° F (5° C) or exceed 110° F (43° C).
- Allow the following clearances for ease of installation, proper air circulation, and electrical connections:
 

Sides	3/8"
Back & Top	1"
- Do Not block the toe grille on the lower front of your refrigerator. Sufficient air circulation is essential for the proper operation of your refrigerator.

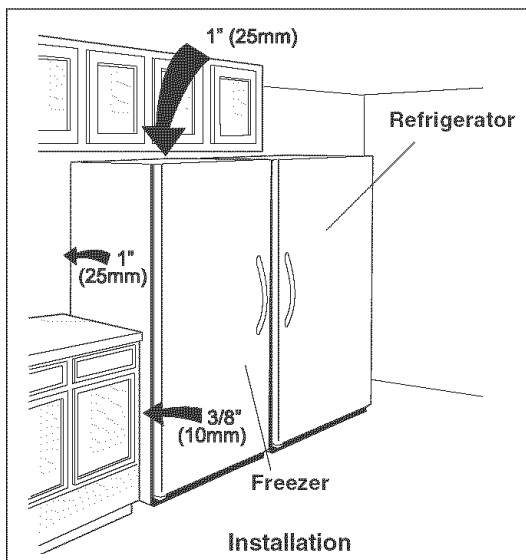

### NOTE

The exterior walls of the refrigerator may become quite warm as the compressor works to transfer heat from the inside. Temperatures as much as 30° F warmer than room temperature can be expected.

### DOOR OPENING

### NOTE

If your refrigerator is placed with the door hinge side against a wall, you may have to allow additional space so the door can be opened wider.

## LEVELING

The refrigerator must have all bottom corners resting firmly on a solid floor. The floor must be strong enough to support a fully loaded refrigerator. **NOTE:** It is **Very Important** for your refrigerator to be level in order to function properly. If the refrigerator is not leveled during installation, the door may be misaligned and not close or seal properly, causing cooling, frost, or moisture problems.

### To Level Refrigerator:

After discarding crating screws and wood base, use a carpenter's level to level the refrigerator from front-to-back. Adjust the plastic leveling feet in front, ½ bubble higher, so that the door closes easily when left halfway open.

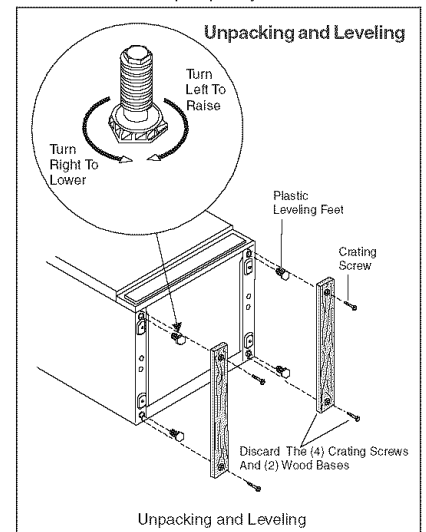

### Leveling Instructions for all Refrigerator/Freezer Pair:

- Remove two leg levelers provided in literature bag. While unit is lying on its back for wood skid removal, install both leg levelers in rear of unit.
- Level door of first unit using all four levelers and slide unit into place. Recheck for levelness and adjust if necessary.
- Measure distance from floor to bottom of door on first unit. Adjust and level second unit so door height matches.
- Leg Level Adjustments
  - One full turn of all four leg levelers will raise door 5/32".
  - One full turn of both front leg levelers will raise door 3/16" and tilt top of door back 7/16".
  - One full turn of both rear leg levelers will lower door 1/32" and tilt top of door forward 7/16".
  - One full turn of both side leg levelers will raise door 3/16" and tilt top of door 3/8".
- Slide second unit into place leaving a minimum gap of 3/16" between units for door swing clearance.
- This last step may require at least one extraction of the second unit to properly align units in a "built-in" application.

### CAUTION

To allow door to close and seal properly, do not let food packages extend past the front of the shelves

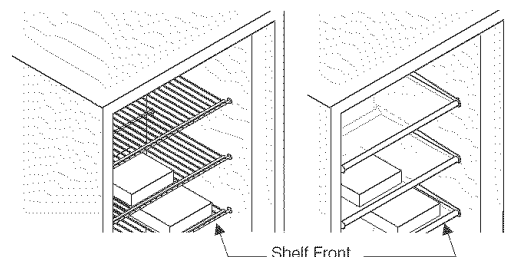

## DOOR REMOVAL

### If door must be removed :

1. Gently lay refrigerator on its back, on a rug or blanket.
2. Remove two base screws and base panel.
3. Remove bottom hinge screws.
4. Remove plastic top hinge cover.
5. Remove screws from top hinge.
6. Remove top hinge from cabinet.
7. Remove door and bottom hinge from cabinet.
8. To replace door, reverse the above order and securely tighten all screws to prevent hinge slippage.

## SETTING THE TEMPERATURE CONTROL

### COOL DOWN PERIOD

For safe food storage, allow 4 hours for the refrigerator to cool down completely. The refrigerator will run continuously for the first several hours.

### TEMPERATURE CONTROL

The temperature control is located inside the refrigerator compartment. The temperature is factory preset to provide satisfactory food storage temperatures. However, the temperature control is adjustable to provide a range of temperatures for your personal satisfaction. If a colder temperature is desired, turn the temperature control knob toward COLDEST and allow several hours for temperatures to stabilize between adjustments.

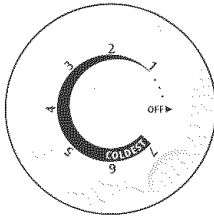

Cold Control

## REFRIGERATOR FEATURES

### INTERIOR LIGHTING

The lights come on automatically when the door is opened. To replace the light bulb, turn the temperature control to OFF and **unplug the electrical cord**. Replace the old bulb with a bulb of the same wattage.

### ADJUSTABLE INTERIOR SHELVES

Multi-position adjustable interior shelves can be moved to any position for larger or smaller packages. The shipping spacers that stabilize the shelves for shipping may be removed and discarded.

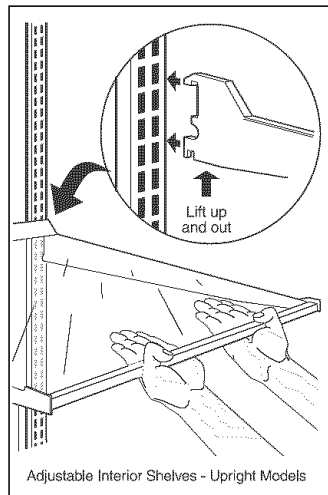

Adjustable Interior Shelves - Upright Models

## TO ADJUST CANTILEVER SHELVES

### NOTE

Cantilever shelves are supported at the back of the freezer.

- 1 Lift front edge up.
- 2 Pull shelf out.

Replace the shelf by inserting the hooks at rear of the shelf into the wall bracket. Lower the shelf into the desired slots and lock into position.

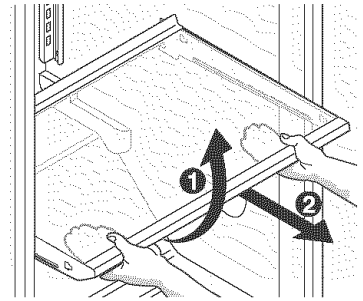

### MID LEVEL LIGHTING

The lights come on automatically when the door is opened. To replace the light bulb, turn the temperature control to OFF and **unplug the electrical cord**. Remove the lens from the lamp housing by unsnapping it from the lamp housing using your fingers or a screwdriver. Be careful not to break the locking tabs on the lamp housing. Replace the old bulb with a bulb of the same type and wattage. To replace the lens, snap one side of the lens opening to the tab on the lamp housing. Then carefully attach the other side.

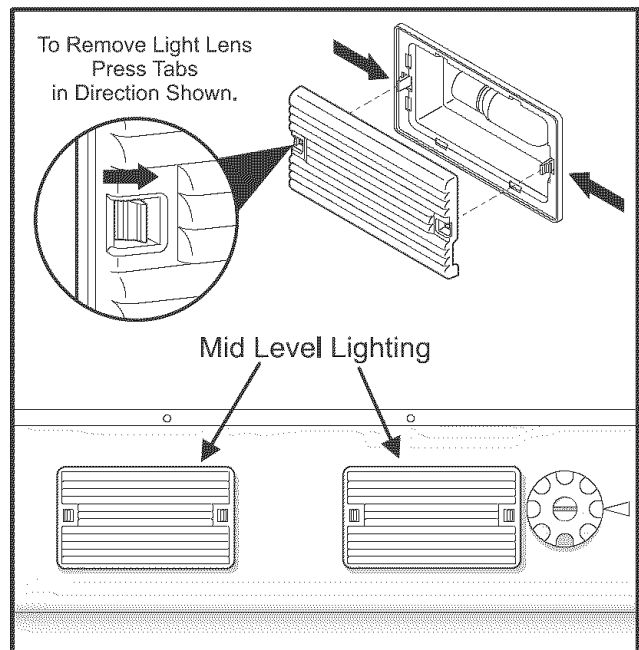

### DOOR STORAGE

Door bins, shelves, and racks are provided for convenient storage of jars, bottles, and cans. Frequently used items can be quickly selected.

Some models have door racks or bins that can accommodate gallon-sized plastic drink containers and economy-sized jars and containers.

The dairy compartment, which is warmer than the general food storage section, is intended for short term storage of cheese, spreads, or butter.

## ADJUSTABLE DOOR BINS

Some models have adjustable door bins that can be moved to suit individual needs.

To move door bins

1. Lift bin straight up.
2. Remove bin.
3. Place bin in desired position.
4. Lower bin onto supports until locked in place.

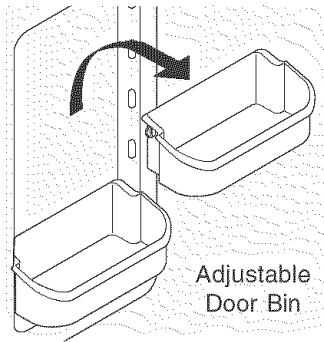

## DELI DRAWER (SOME MODELS)

Some models are equipped with a Deli Drawer for storage of luncheon meats, spreads, cheeses, and other deli items.

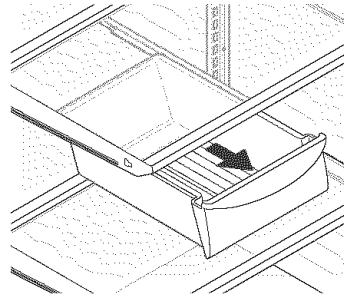

## CRISPERS (SOME MODELS)

The crispers, located under the bottom refrigerator shelf, are designed for storing fruits, vegetables, and other fresh produce. Wash items in clear water and remove excess water before placing them in the crispers. Items with strong odors or high moisture content should be wrapped before storing.

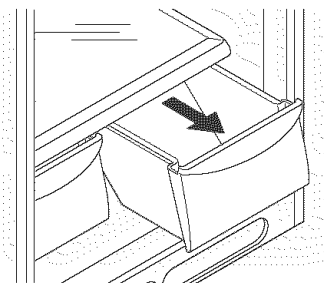

## HUMIDITY CONTROL (SOME MODELS)

The Humidity Control, present on some models with crisper drawers, allows you to adjust the humidity within the crisper. This can extend the life of fresh vegetables that keep best in high humidity.

### NOTE

Leafy vegetables keep best when stored with the Humidity Control set on **High Humidity**, or in a drawer without a Humidity Control. This keeps incoming air to a minimum and maintains maximum moisture content.

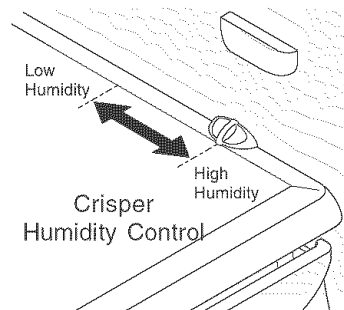

## FOOD STORAGE AND ENERGY SAVING TIPS

### FOOD STORAGE IDEAS

#### Fresh Food Storage

- The fresh food compartment should be kept between 34° F and 40° F with an optimum temperature of 37° F.

- Avoid overcrowding the refrigerator shelves. This reduces the circulation of air around the food and results in uneven cooling.

#### Fruits and Vegetables

- Storage in the crisper drawers traps moisture to help preserve the fruit and vegetable quality for longer time periods.

#### Meat

- Raw meat and poultry should be wrapped securely so leakage and contamination of other foods or surfaces does not occur.

## ENERGY SAVING IDEAS

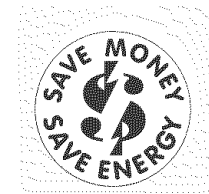

- Locate the refrigerator in the coolest part of the room, out of direct sunlight, and away from heating ducts or registers. Do not place the refrigerator next to heat-producing appliances such as a range, oven, or dishwasher. If this is not possible, a section of cabinetry or an added layer of insulation between the two appliances will help the refrigerator operate more efficiently.
- Level the refrigerator so that the door closes tightly.
- Refer to the “**SETTING THE TEMPERATURE CONTROL**” section for the suggested temperature control settings.
- Do not overcrowd the refrigerator or block cold air vents. Doing so causes the refrigerator to run longer and use more energy.
- Cover foods and wipe containers dry before placing them in the refrigerator. This cuts down on moisture build-up inside the unit.
- Organize the refrigerator to reduce door openings. Remove as many items as needed at one time and close the door as soon as possible.

## VACATION AND MOVING TIPS

### Short Vacations:

Leave the refrigerator operating during vacations of less than three weeks.

### Long Vacations:

If the refrigerator will not be used for several months:

- Remove all food and unplug the power cord.
- Clean and dry the interior thoroughly.
- Leave the refrigerator door open slightly, blocking it open if necessary, to prevent odor and mold growth.

### Moving: When moving the refrigerator, follow these guidelines to prevent damage:

- Disconnect the power cord plug from the wall outlet.
- Remove foods, then defrost, and clean the refrigerator.
- Secure all loose items such as base panel, baskets, and shelves by taping them securely in place to prevent damage.
- In the moving vehicle, secure refrigerator in an upright position to prevent movement. Also protect outside of refrigerator with a blanket, or similar item.

## CARE AND CLEANING

Keep your refrigerator clean to prevent odor build-up. Wipe up any spills immediately and clean at least twice a year. **Never** use metallic scouring pads, brushes, abrasive cleaners or strong alkaline solutions on any surface. **Do not** wash any removable parts in a dishwasher. **Always unplug the electrical power cord from the wall outlet before cleaning.**

### CAUTION

- When moving the refrigerator, pull straight out. Do not shift the refrigerator from side to side as this may tear or gouge the floor covering.
- Damp objects stick to cold metal surfaces. Do not touch interior metal surfaces with wet or damp hands.

### NOTE

- Turning the refrigerator temperature control to "OFF" turns off the compressor, but does not disconnect electrical power to the light bulb or other electrical components. **To turn off power to your refrigerator, you must unplug the power cord from the wall outlet.**
- Do not use razor blades or other sharp instruments which can scratch the appliance surface when removing adhesive labels. Any glue left from tape or labels can be removed with a mixture of warm water and mild detergent, or, touch the glue residue with the sticky side of tape you have already removed. **Do not remove the serial plate.**

**Care & Cleaning Chart**

Part	What To Use	Tips and Precautions
Interior/Door Liner	<ul style="list-style-type: none"> <li>• Soap and water</li> <li>• Baking soda and water</li> </ul>	Use 2 tablespoons of baking soda in 1 quart of warm water. <b>Be sure to wring excess water out of sponge or cloth before cleaning around controls, light bulb or any electrical part.</b>
Door Gaskets	<ul style="list-style-type: none"> <li>• Soap and water</li> </ul>	Wipe gaskets with a clean soft cloth.
Drawers/Bins	<ul style="list-style-type: none"> <li>• Soap and water</li> </ul>	Do not wash any removable items (bins, drawers, etc.) in dishwasher.
Glass Shelves	<ul style="list-style-type: none"> <li>• Soap and water</li> <li>• Glass cleaner</li> <li>• Mild liquid sprays</li> </ul>	Allow glass to warm to room temperature before immersing in warm water.
Exterior and Handles	<ul style="list-style-type: none"> <li>• Soap and water</li> <li>• Non Abrasive Glass Cleaner</li> </ul>	Do not use commercial household cleaners, ammonia, or alcohol to clean handles. Use a soft cloth to clean smooth handles. <b>Do Not use a dry cloth to clean smooth doors.</b>
Exterior and Handles (Stainless Steel Models Only)	<ul style="list-style-type: none"> <li>• Soap and water</li> <li>• Ammonia</li> <li>• Stainless Steel Cleaners</li> </ul>	Clean stainless steel front and handles with soapy water and a dishcloth. Rinse with clean water and a soft cloth. Wipe stubborn spots with an ammonia-soaked paper towel, and rinse. Use a non-abrasive stainless steel cleaner. These cleaners can be purchased at most home improvement or major department stores. Always follow manufacturer's instructions. <b>NOTE: Always clean, wipe and dry with the grain to prevent cross-grain scratching.</b> Wash the rest of the cabinet with warm water and mild liquid detergent. Rinse well, and wipe dry with a clean soft cloth.



## BEFORE YOU CALL

TROUBLESHOOTING GUIDE	Before calling for service, review this list. It may save you time and expense. This list includes common occurrences that are not the result of defective workmanship or materials in this appliance.	
PROBLEM	CAUSE	CORRECTION
<b>REFRIGERATOR OPERATION</b>		
<b>Refrigerator does not run.</b>	<ul style="list-style-type: none"> <li>• Refrigerator is plugged into a circuit that has a ground fault interrupt.</li> <li>• Temperature control is in the OFF position.</li> <li>• Refrigerator may not be plugged in, or plug may be loose.</li> <li>• House fuse blown or tripped circuit breaker.</li> <li>• Power outage.</li> </ul>	<ul style="list-style-type: none"> <li>• Use another circuit. If you are unsure about the outlet, have it checked by a certified technician.</li> <li>• See "<b>SETTING THE TEMPERATURE CONTROL</b>" Section.</li> <li>• Ensure plug is tightly pushed into outlet.</li> <li>• Check/replace fuse with a 15 amp time-delay fuse. Reset circuit breaker.</li> <li>• Check house lights. Call local Electric Company.</li> </ul>
<b>Refrigerator runs too much or too long.</b>	<ul style="list-style-type: none"> <li>• Room or outside weather is hot.</li> <li>• Refrigerator has recently been disconnected for a period of time.</li> <li>• Large amounts of warm or hot food have been stored recently.</li> <li>• Doors are opened too frequently or too long.</li> <li>• Refrigerator door may be slightly open.</li> <li>• Refrigerator gasket is dirty, worn, cracked, or poorly fitted.</li> </ul>	<ul style="list-style-type: none"> <li>• It's normal for the refrigerator to work harder under these conditions.</li> <li>• It takes 4 hours for the refrigerator to cool down completely.</li> <li>• Warm food will cause refrigerator to run more until the desired temperature is reached.</li> <li>• Warm air entering the refrigerator causes it to run more. Open doors less often.</li> <li>• See "<b>DOOR PROBLEMS</b>" Section.</li> <li>• Clean or change gasket. Leaks in the door seal will cause refrigerator to run longer in order to maintain desired temperature.</li> </ul>
<b>Interior refrigerator temperature is too cold.</b>	<ul style="list-style-type: none"> <li>• Temperature Control is set too low.</li> </ul>	<ul style="list-style-type: none"> <li>• Turn the control to a warmer setting. Allow several hours for the temperature to stabilize.</li> </ul>
<b>Interior refrigerator temperature is too warm.</b>	<ul style="list-style-type: none"> <li>• Temperature Control is set too warm.</li> <li>• Door is kept open too long or is opened too frequently.</li> <li>• Door may not be sealing properly.</li> <li>• Large amounts of warm or hot food may have been stored recently.</li> <li>• Refrigerator has recently been disconnected for a period of time.</li> </ul>	<ul style="list-style-type: none"> <li>• Turn control to a colder setting. Allow several hours for the temperature to stabilize.</li> <li>• Warm air enters the refrigerator every time the door is opened. Open the door less often.</li> <li>• See "<b>DOOR PROBLEMS</b>" Section.</li> <li>• Wait until the refrigerator has had a chance to reach its selected temperature.</li> <li>• Refrigerator requires 4 hours to cool down completely.</li> </ul>
<b>Refrigerator external surface temperature is warm.</b>	<ul style="list-style-type: none"> <li>• The external refrigerator walls can be as much as 30°F warmer than room temperature.</li> </ul>	<ul style="list-style-type: none"> <li>• This is normal while the compressor works to transfer heat from inside the refrigerator cabinet.</li> </ul>
<b>SOUND AND NOISE</b>		
<b>Louder sound levels whenever refrigerator is on.</b>	<ul style="list-style-type: none"> <li>• Modern refrigerators have increased storage capacity and more stable temperatures. They require a high efficiency compressor.</li> </ul>	<ul style="list-style-type: none"> <li>• This is normal. When the surrounding noise level is low, you might hear the compressor running while it cools the interior.</li> </ul>
<b>Longer sound levels when compressor comes on.</b>	<ul style="list-style-type: none"> <li>• Refrigerator operates at higher pressures during the start of the ON cycle.</li> </ul>	<ul style="list-style-type: none"> <li>• This is normal. Sound will level off or disappear as refrigerator continues to run.</li> </ul>

## BEFORE YOU CALL

PROBLEM	CAUSE	CORRECTION
<b>SOUND AND NOISE (Cont.)</b>		
Popping or cracking sound when compressor comes on.	<ul style="list-style-type: none"> <li>• Metal parts undergo expansion and contraction, as in hot water pipes.</li> </ul>	<ul style="list-style-type: none"> <li>• This is normal. Sound will level off or disappear as refrigerator continues to run.</li> </ul>
Bubbling or gurgling sound, like water boiling.	<ul style="list-style-type: none"> <li>• Refrigerant (used to cool refrigerator) is circulating throughout the system.</li> </ul>	<ul style="list-style-type: none"> <li>• This is normal.</li> </ul>
Vibrating or rattling noise.	<ul style="list-style-type: none"> <li>• Refrigerator is not level. It rocks on the floor when it is moved slightly.</li> <li>• Refrigerator is touching the wall.</li> </ul>	<ul style="list-style-type: none"> <li>• Level the unit. Refer to "Leveling" in the "<b>FIRST STEPS</b>" Section.</li> <li>• Relevel the refrigerator or move refrigerator slightly. Refer to "Leveling" in the "<b>FIRST STEPS</b>" Section.</li> </ul>
Snapping Sound.	<ul style="list-style-type: none"> <li>• Cold Control turning the refrigerator on and off.</li> </ul>	<ul style="list-style-type: none"> <li>• This is normal.</li> </ul>
<b>WATER/MOISTURE/FROST INSIDE REFRIGERATOR</b>		
Moisture forms on inside of refrigerator walls.	<ul style="list-style-type: none"> <li>• Weather is hot and humid.</li> <li>• Door may not be sealing properly.</li> <li>• Door is kept open too long, or is opened too frequently.</li> </ul>	<ul style="list-style-type: none"> <li>• This is normal.</li> <li>• See "<b>DOOR PROBLEMS</b>" Section.</li> <li>• Open the door less often.</li> </ul>
<b>WATER/MOISTURE/FROST OUTSIDE REFRIGERATOR</b>		
Moisture forms on outside of refrigerator.	<ul style="list-style-type: none"> <li>• Door may not be sealing properly, causing the cold air from inside the refrigerator to meet warm moist air from outside.</li> </ul>	<ul style="list-style-type: none"> <li>• See "<b>DOOR PROBLEMS</b>" Section.</li> </ul>
<b>ODOR IN REFRIGERATOR</b>		
Odors in refrigerator.	<ul style="list-style-type: none"> <li>• Interior needs to be cleaned.</li> <li>• Foods with strong odors are in the refrigerator.</li> </ul>	<ul style="list-style-type: none"> <li>• Clean interior with sponge, warm water, and baking soda.</li> <li>• Cover the food tightly.</li> </ul>
<b>DOOR PROBLEMS</b>		
Door will not close.	<ul style="list-style-type: none"> <li>• Refrigerator is not level. It rocks on the floor when it is moved slightly.</li> </ul>	<ul style="list-style-type: none"> <li>• This condition can force the cabinet out of square and misalign the door. Refer to "Leveling" in the "<b>FIRST STEPS</b>" Section.</li> </ul>
<b>LIGHT BULB IS NOT ON</b>		
Light bulb is not on.	<ul style="list-style-type: none"> <li>• Light bulb is burned out.</li> <li>• No electric current is reaching the refrigerator.</li> </ul>	<ul style="list-style-type: none"> <li>• Follow directions under "Interior Light" or "Mid Level Light" in the "<b>REFRIGERATOR FEATURES</b>" Section.</li> <li>• See "<b>BEFORE YOU CALL - REFRIGERATOR OPERATION</b>" Section.</li> </ul>