

GE Monogram®

Installation

Instructions

30" Convection
Built-In Ovens

Models

ZET857SYSS

ZET857DYSB

ZET857BYBB

ZET857WYWW

ZET837SYSS

ZET837DYSB

ZET837BYBB

ZET837WYWW

Before you begin—Read these instructions completely and carefully.

IMPORTANT: Save these instructions for local inspector’s use.

IMPORTANT: OBSERVE ALL GOVERNING CODES AND ORDINANCES.

NOTE TO INSTALLER: Be sure to leave these instructions with the Consumer.

NOTE TO CONSUMER: Keep these instructions with your Use and Care Book for future reference.

⚠ WARNING This appliance must be properly grounded. See “Electrical Supply”, page 9.

If you have questions concerning the installation of this product, call the GE Answer Center® Consumer Information Service at 800.626.2000, 24 hours a day, 7 days a week.

Proper installation is the responsibility of the installer. Product failure due to improper installation is not covered under the GE Appliance Warranty. See the Use & Care Guide for warranty information.

If you received a damaged oven, you should contact your dealer.

CAUTION:

- This oven should be installed by a qualified installer or service technician.
- Never use the oven for warming or heating a room. Prolonged use of the oven without adequate ventilation can be hazardous.

Check with local utilities for electrical codes which apply in your area. Local codes vary. Installation, electrical connections and grounding must comply with applicable codes. In the absence of local codes, the oven should be installed in accordance with National Electrical Code ANSI/NFPA 70-1990.

Contents

Design Information

Models Available 3
Dimensions and Clearances 3
Cabinet Style Options 4

Cabinetry

Tools and Materials required 5
Framed Cabinet, Double Oven 5
Framed Cabinet, Single Oven 6
Frameless Cabinets 7

Installation

Provide Oven Supports 8
Install Oven Supports 8
Step 1: Remove the Packaging 8
Electrical Supply 9
Step 2: Install Junction Box 9
208V Electrical Supply 10
Step 3: Remove Oven Doors 11
Step 4: Rotate Cable through Cutout 11
Step 5: Secure Oven to Cabinet 11
Step 6: Replace the Oven Door 12
Step 7: Connect Electrical 12

Cabinetry Modification Suggestions

Determine Need for Filler Panels 13
Filler Panel Construction 13
Cut Rail for Filler Panel 14
Cut Appearance Panel 14
Determine Location of Cleats 14
Cut and Secure Cleats to Filler Panel 15
Secure Rail to Appearance Panel 15
Secure Assembled Filler Panel to Cabinet 15

Design Information

30" Built-In Convection Ovens

Models available

ZET857SYSS

Stainless steel double convection oven

ZET857DYSS

Stainless steel on black double convection oven

ZET857BYBB

Black double convection oven

ZET857WYWW

White double convection oven

ZET837SYSS

Stainless steel single convection oven

ZET837DYSS

Stainless steel on black single convection oven

ZET837BYBB

Black single convection oven

ZET837WYWW

White single convection oven



With both single and double built-in styles, contemporary Monogram ovens offer an array of choices for the custom kitchen:

- Built-in double convection ovens
- Built-in single convection ovens
- Monogram built-in ovens are available in stainless steel, stainless and black, white glass and black glass.

Dimensions and clearances

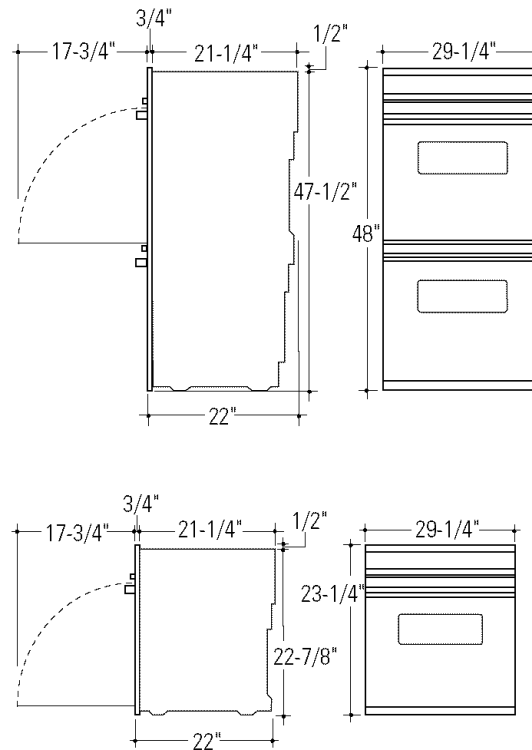

Cabinet style options

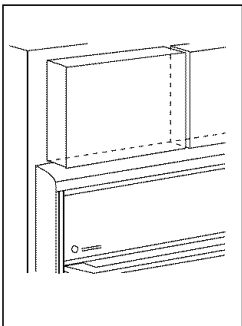
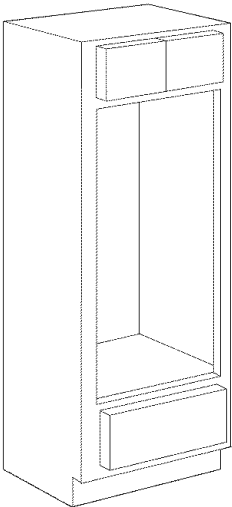

Front Framed Partial Overlay Door

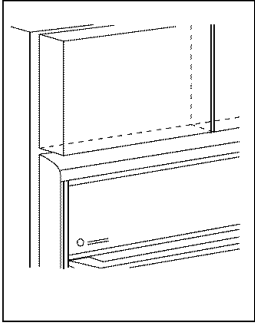
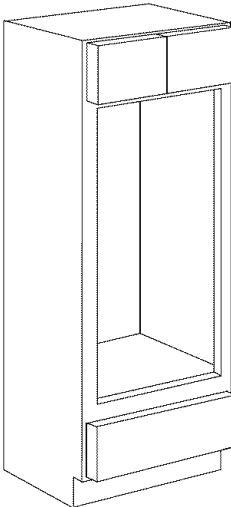

Front Framed Full Overlay Door

Monogram ovens are installed directly into a wall or wall oven cabinetry, 30" minimum width. The front surface of the ovens will be nearly flush with surrounding cabinetry. To obtain optimal appearance, cabinet cutouts must be exact. The examples shown here illustrate typical styles of 30" cabinets and oven fit. Installation instructions for each of these basic cabinetry styles are provided in this section.

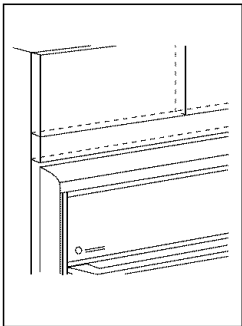
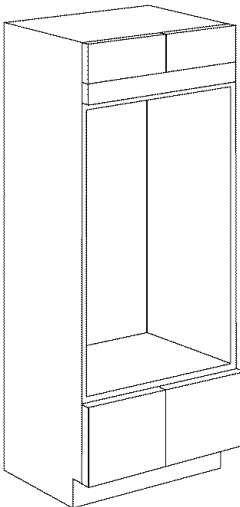

Frameless

Designer Note: Whenever possible, align the oven with cabinetry details such as drawers, doors and reveals.

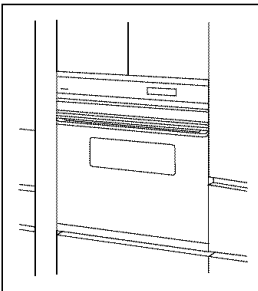

Tools and materials required

- 2" x 4" lumber for runners
- Saw
- Level
- Phillips screwdriver, wood screws and adhesive or other hardware for installing runners or shelf to support oven.

Ovens are designed for installation in a cabinet 30" min. wide.

- Cut 2" x 4" runners of appropriate length or solid shelf to support oven.
- Attach runners or solid shelf in opening as shown.
- Runners must be level, rigidly mounted and capable of supporting 300 pounds.

Framed cabinet double oven

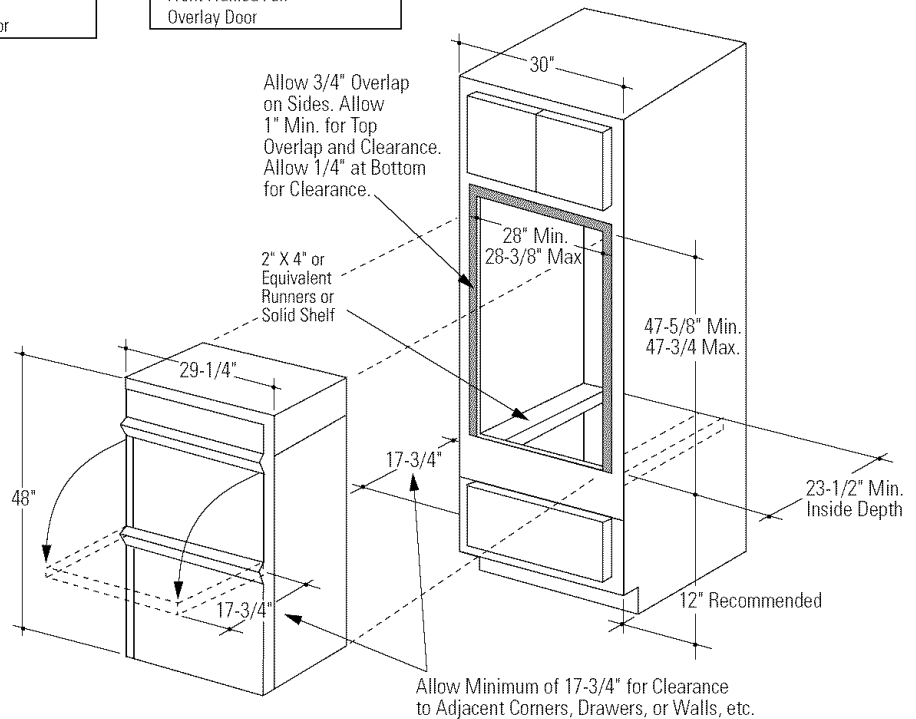
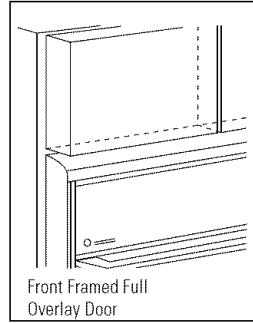
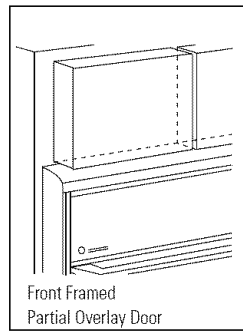

Use the information in this dimension drawing for typical framed cabinets. The front face of the oven will be flush with cabinetry doors or drawers.

Order a double oven cabinet.

Rough opening for double oven must be:

- Depth—23-1/2" min. from inside back to front of cabinet frame.
- Width—28" min., 28-3/8" max.
- Height—47-5/8" min., 47-3/4" max.

- Installing 12" from floor will place base of upper oven at countertop level.
 - May be more than 12" from floor, depending upon user preference.
- These Monogram ovens require 3/4" overlap to both sides. Allow 1" min. for top overlap and clearance to upper doors.
- Oven overlaps will conceal raw edges on the top and both sides of the cutout.

Framed cabinet single oven

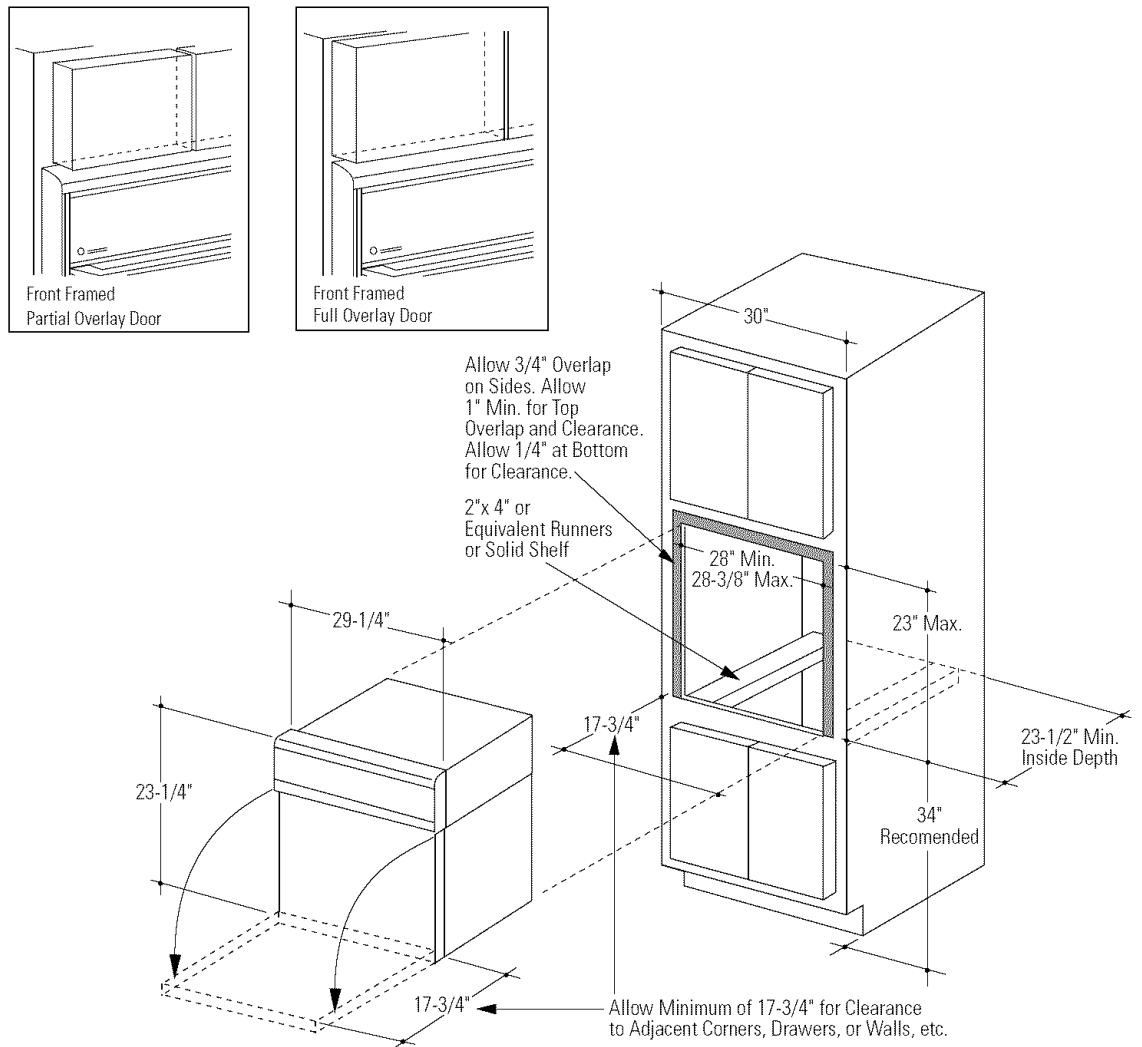

Use the information in this dimension drawing for typical framed cabinets. The front face of the oven will be flush with cabinetry doors or drawers.

Order a single oven cabinet.

Rough opening for single oven must be:

- Depth—23-1/2" min. from inside back to front of cabinet frame.
- Width—28" min., 28-3/8" max.
- Height—23" max.

- 34" from floor is recommended to bring oven door to countertop height when opened.
- All Monogram ovens require 3/4" overlap on both sides. Allow 1" min. for top overlap and clearance to upper doors.
- Oven overlaps will conceal raw edges on top and both sides of cutout.

Single ovens can be installed below a countertop. Use the cutout dimensions shown on this page. If the cabinets being used have an opening that is taller than the maximum dimensions shown, filler panels can be made to fill the gaps. See Cabinetry Modifications Suggestions on page 13 for more information.

Frameless cabinets

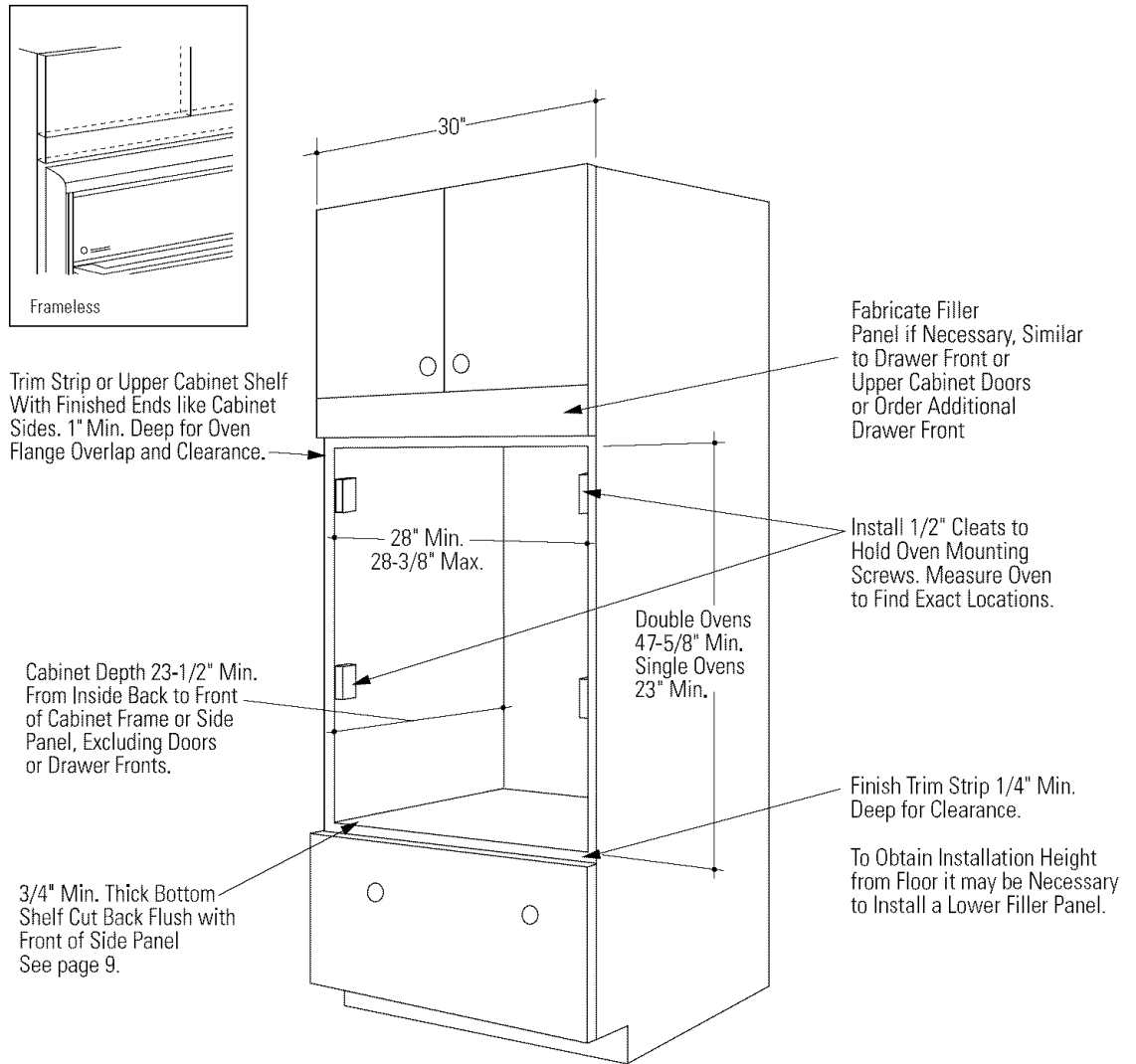

Use the information in this dimension drawing for typical frameless cabinets. The front face of the oven will be flush with cabinetry doors or drawers.

Whenever possible, order 30" frameless cabinet with the cutout sized to fit the oven. If you are using stock cabinets, additional finished filler pieces may be required to cover openings.

Rough opening for single and double ovens:

- Depth—23-1/2" min. from inside back to front of cabinet or side panel, excluding doors or drawer fronts.
- Width—28" min.
 - Frameless cabinet cutout width may be up to 28-3/4". Add 1/2" cleats to the sides, flush with the front edge of the side panels to accept mounting screws.

- Height—for double oven 47-5/8" min.
- Height—for single oven 23" min.

Both single and double ovens require 3/4" overlap around edges of opening on both sides. Allow 1/2" for top overlap.

- Allow 1/8" clearance between top of oven and cabinet door or panel and 1/8" between bottom of oven and cabinet drawer.
- Installation of double oven requires a total height of 48-1/4" including clearances at top and bottom.
- Installation of single oven requires a total height of 23-1/2" including clearances.

Installation

30" Built-In Convection Ovens

Provide oven supports

The ovens may be supported by either a solid bottom or 2 x 4 runners.

- The support must be level and rigidly mounted, flush with the bottom edge of the cutout.
- The entire weight of the oven is supported by 2 x 4 runners or the solid floor and must be capable of supporting 300 lbs. for double ovens and 200 lbs. for single ovens.

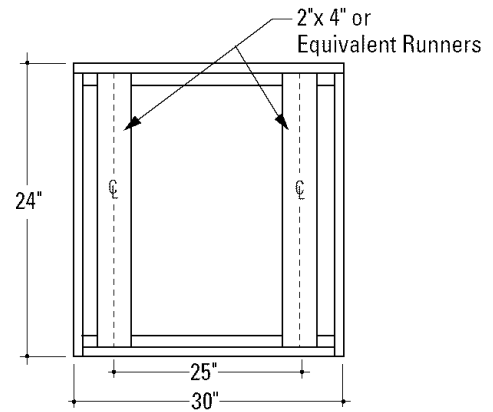

Install oven supports

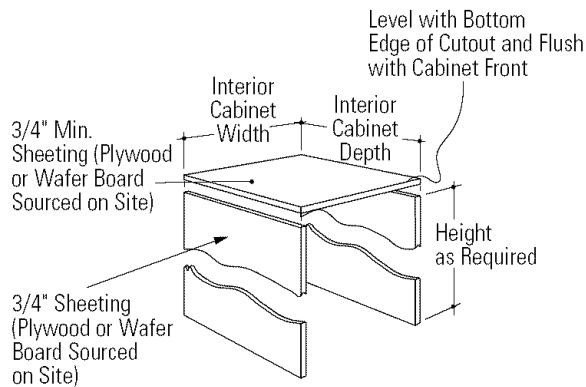

If a solid bottom is used:

- Cut two pieces of 3/4" thick sheeting, to fit inside cabinet depth and available inside cabinet height. If there is no interference below the cutout, such as drawer runners, the sheeting can rest on the floor. Secure the sheeting strips or pieces to the cabinet walls with screws. Lay 2 x 4 or solid bottom on top of the sheeting and drive screws through the top and into the sheeting.

Step 1 Remove the Packaging

- Remove the carton, plastic covering, and styrofoam side/corner posts.
- To prevent damage to the floor, do not remove the styrofoam base until the oven is ready to be installed.
- Remove oven contents, shelves and packaging.
- Be sure to remove protective tape from the door latch pin.

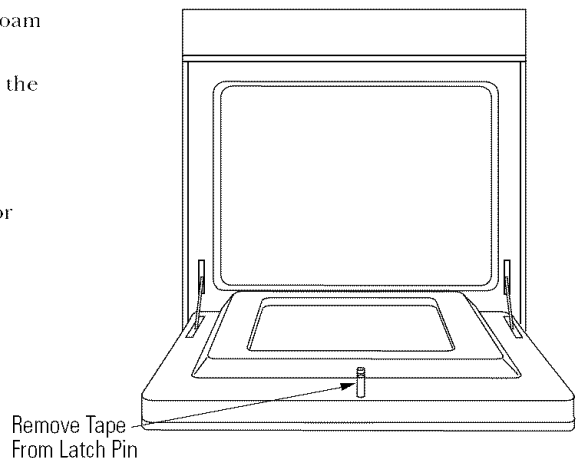

Electrical supply

- Junction box
- Electrical cable—3-conductor or 4-conductor wire—as required by local codes
- U.L. listed conduit connector
- Wire cutters and wire stripper

Note: Do not use an extension cord with these appliances. Do not shorten the flexible power cable.

These Monogram built-in ovens require a separate, properly grounded 3-wire 120/208 or 120/240 volt, 60 Hz power supply, protected by a time delay fuse or circuit breaker. Ovens are supplied with a flexible power cable, which must be attached to a junction box. The cable length is 53" for both single and double conventional ovens.

Double ovens are rated 6.3 KW at 240 volt, and 5.1 KW at 208 volt.

Single ovens are rated 3.3 KW at 240 volt, and 2.8 KW at 208 volt.



Electrical Shock Hazard

- The electrical power to the oven branch circuit must be shut off while line connections are being made.
- Use copper wiring only.
- Electrical ground is required on this

appliance. The free end of the green wire (the ground wire) must be connected to a suitable ground.

This wire must remain grounded to the oven.

- If cold water pipe is interrupted by plastic, non-metallic gaskets, union connections or other insulating materials, DO NOT use for grounding.

- DO NOT ground to a gas pipe.
 - DO NOT have a fuse in the NEUTRAL or GROUNDING circuit. A fuse in the NEUTRAL or GROUNDING circuit could result in an electrical shock.
 - Check with a qualified electrician if you are in doubt as to whether the appliance is properly grounded.
- Failure to follow these instructions could result in serious injury or death.

Step 2 Install junction box

The conduit is located in the center at the top rear of the oven.

For double oven:

- Locate and install the junction box within reach of the power cable.
 - Through the left or right of cabinet wall into adjacent cabinet.
 - or, below the cutout floor.
 - or, above the cutout, into the top cabinet.

For single oven:

- Locate and install the junction box within reach of the power cable.
 - Below the cutout floor.
 - Or, through the left or right of cabinet wall into adjacent cabinet.
 - or, above the cutout, into the top cabinet.

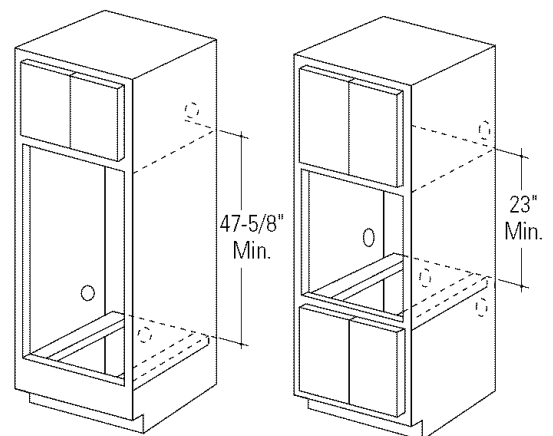

Double Oven:
Locate Junction Box
in one of the locations

Single Oven:
Locate Junction Box
in one of the locations

Installation

30" Built-In Convection Ovens

208V Electrical supply

⚠ WARNING These ovens are pre-wired for connection to 240 volt, 60 Hz., supply. If connecting to a 208 volt supply, modifications must be made.

If connecting to a 208 volt, 60 Hz., supply, a jumper must be used across two terminals.

- For double ovens, there are two jumpers, one for the upper oven, one for the lower oven.
- For single ovens there is one jumper.

Single ovens, double ovens— (upper oven)

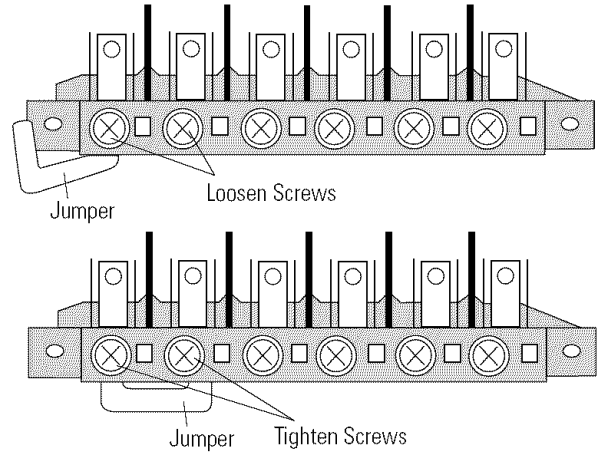
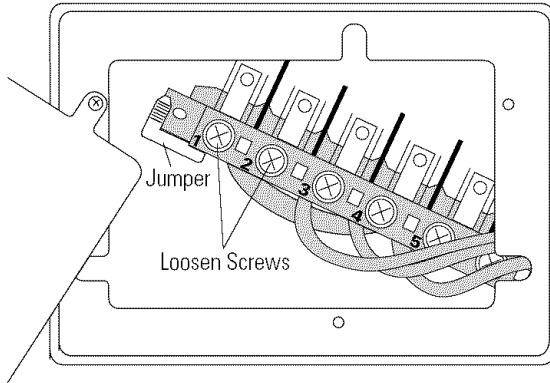

To connect to 208 volt circuit:

- Remove the access panel(s) located on the back of the ovens.
- Loosen the first and second screws in the terminal block as shown.

- Remove the jumper and place between the first and second screws, tighten the screws to hold the jumper in place.
- Replace the access panel(s).

Double ovens— (lower oven)

Double ovens—Lower

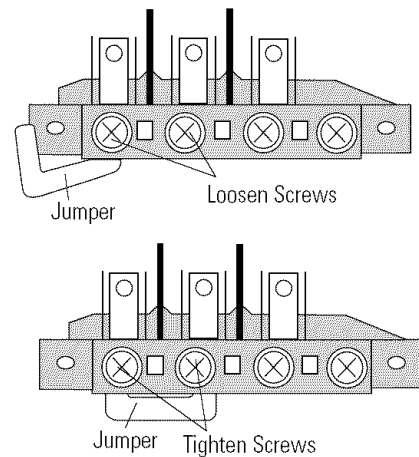
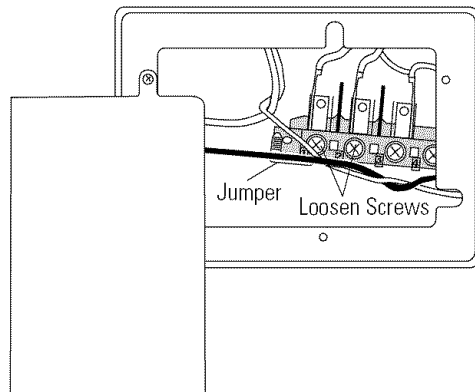

Installation

30" Built-In Convection Ovens

Step 3 Remove Oven Door(s)

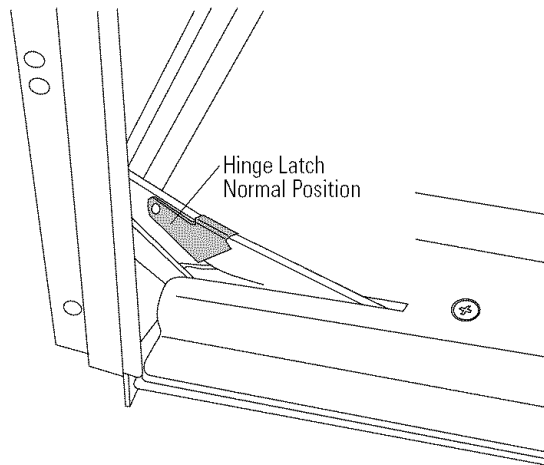

Caution: Do not lift the oven or oven door with handle.

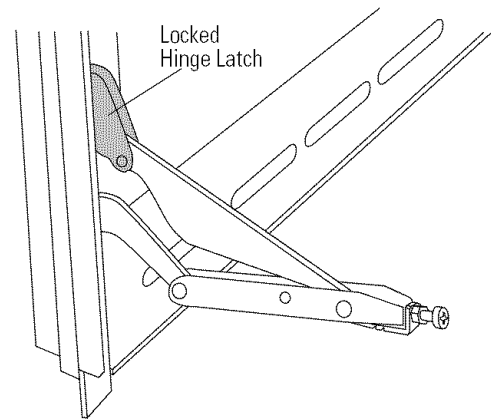

- Open the door fully.
- Push hinge latches up to lock hinges in open position.
- Grasp each side of door and pull the door straight out and away from the oven.
- Lay the oven door on packaging to prevent scratching.

Step 4 Route cable through cutout

Caution: Oven(s) are very heavy. 2 people are required to lift oven(s) into the opening. Ovens have side handles. Grasp side handle with one hand and into oven opening with other hand. Lift the oven to the cabinet opening, very carefully.

With oven in front of cabinet opening:

- Insert power cable into cabinet opening.
- Lift the oven into opening while continuing to feed the cable in the direction of the installed junction box. Be sure the cable does not get pinched between the back of the oven and cabinet wall.

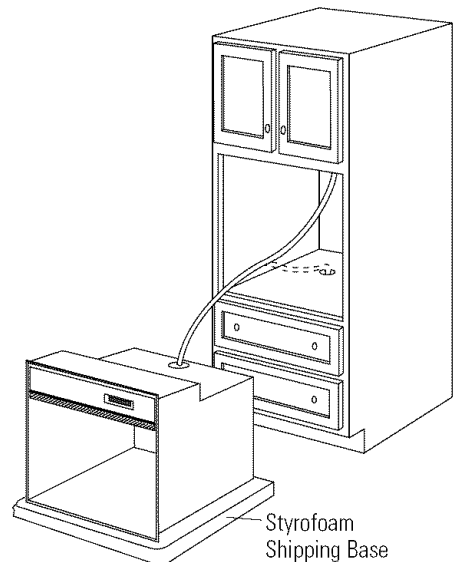

Step 5 Secure oven to cabinet

- Slide oven into cabinet opening.
- Drill 3/32" pilot holes into cabinet frame through mounting holes in oven front frame.
- Secure oven to cabinet with screws furnished.
 - Single ovens, use 2 screws, one on each side.
 - Double ovens, use 4 screws, 2 on each side.

⚠ WARNING

Securely fasten oven to cabinet using the screws provided. Failure to do so could cause the oven to move or tip during use and result in personal injury.

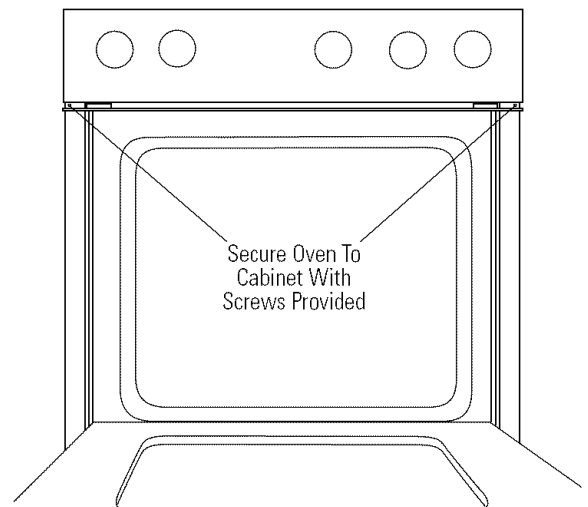

Step 6 Replace the oven door

- Grasp door firmly on both sides.
- Slide the hinge slots in the bottom of the door over the hinges.
- Push the door all the way in against oven.
- Open the door fully and push hinge latches down, as illustrated, on both sides to secure.
- Close the door and open slowly to be sure it moves smoothly.

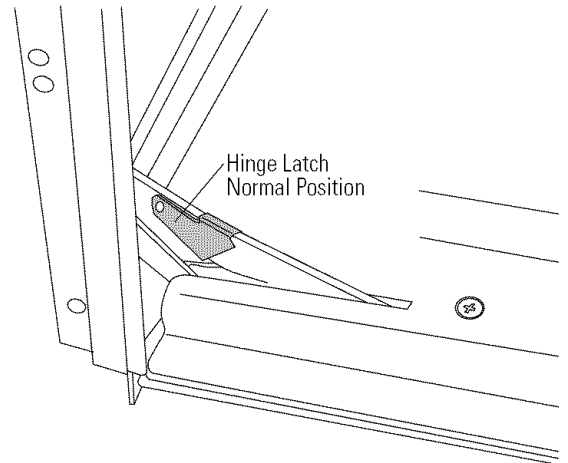

Step 7 Connect electrical



Electrical Shock Hazard

- Electrical ground is required on this appliance.
 - Do Not connect to the electrical supply until appliance is permanently grounded.
 - Disconnect power to the junction box before making the electrical connection.
 - This appliance must be connected to a grounded, metallic, permanent wiring system, or a grounding connector should be connected to the grounding terminal or wire lead on the appliance.
- Failure to do so could result in a fire, personal injury or electrical shock.

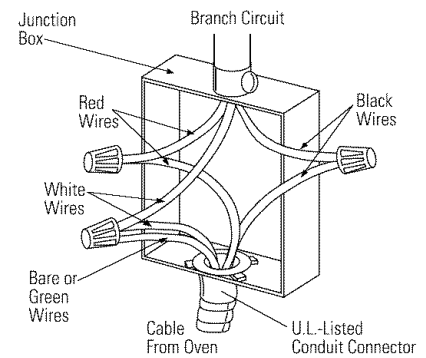

- When connecting to a 3-conductor branch circuit:
 - Connect oven red lead to branch circuit red lead.
 - Connect oven black lead to branch circuit black lead.
 - Connect oven bare copper conductor and white lead to branch circuit neutral lead (white or gray).

- When connecting to a 4-conductor branch circuit:
 - Connect oven red lead to branch circuit red lead.
 - Connect oven black lead to branch circuit black lead.
 - Break connection between oven white lead and oven bare copper conductor.
 - Connect oven white lead to branch circuit neutral lead (white or gray).
 - Connect oven bare copper conductor to branch circuit ground lead (green or bare copper).

Note: Use copper wire only.

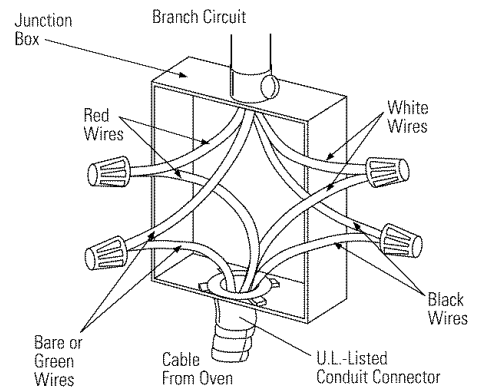

Determine need for filler panels

If the cabinets being used have an opening that is taller than the maximum dimensions indicated for the ovens, filler panels can be made to fill the gaps. Stock filler strips are usually available or for larger gaps order an extra drawer front. Drawer fronts are recommended because they will match the cabinetry and have finished edges. Any cut edges will be seen and should be finished.

Frameless cabinets usually come with a front panel covering the opening. For the optimum finished look, this panel can be removed and used to construct filler panels.

The oven support floor and supports should be installed at the required locations.

If there is a gap between the oven support floor and the bottom of the opening, a bottom filler panel should be constructed to fill the gap.

Measure from the oven support floor to the top of the opening. If the opening height is larger than the maximum cutout height, a filler panel should be constructed to fill the gap.

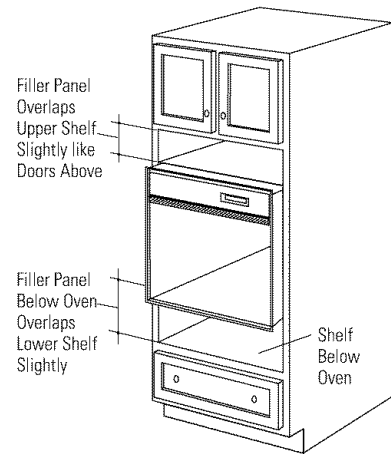

Filler panel construction

We suggest that the filler panel be constructed using 4 pieces:

- Appearance panel to match doors and drawers.
- A rail which will be covered by the oven overlaps and conceal any slight gap between the top or bottom of the oven and the start of the filler panel. The face of the rail should be made of finished matching material; the cut edges and ends do not need to be finished.
- Cleats which will be used to secure the filler panel and rail to the cabinet. One for each side.

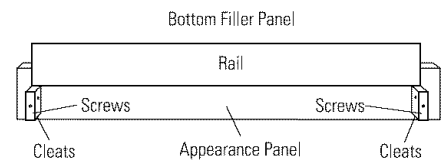
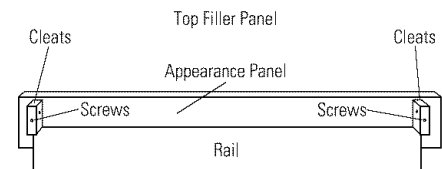

Cut rail for filler panel

Cut the rail out of finished material:

- The width should match cabinet opening width.
- The height of the top rail should be enough to securely attach the rail to the appearance panel, plus 1/4" oven trim overlap.
- The height of the bottom rail should be enough to securely attach the rail to the appearance panel, plus 7/8" oven trim overlap.
- The height of both the top and bottom rails should be adjusted depending upon the height of the gap to be filled or to enhance appearance.

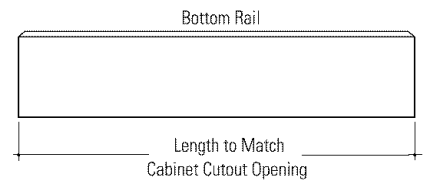
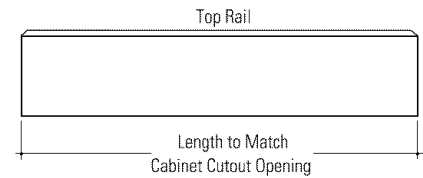

Cut appearance panel

Use drawer fronts for appearance panels or cut finished material and finish raw edges.

- The appearance panel width should match drawer fronts or doors.
- Make the appearance panel appropriate height to fill the gap above or below the oven, allowing for reveals and overlaps to match existing drawers or doors.

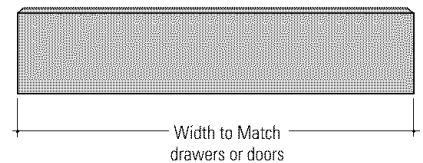

Determine location of cleats

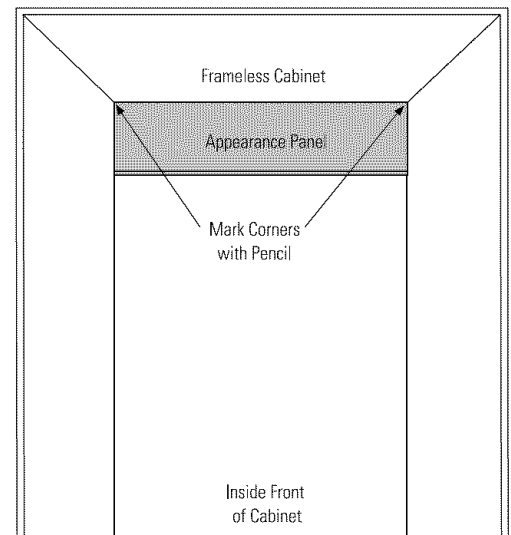
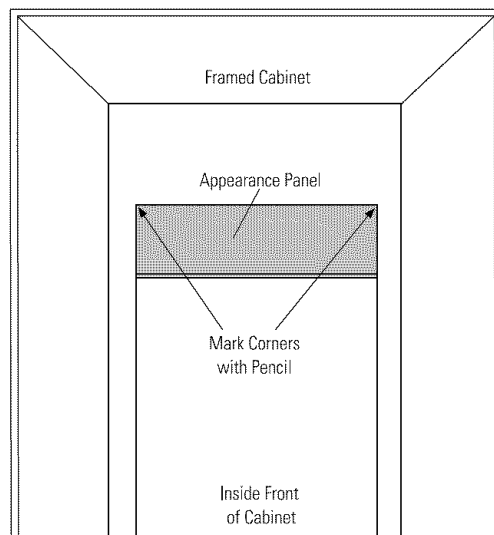

- To find the exact position of the cleats, place the appearance panel onto the cabinet in desired position and align to match the other drawers and doors.

- Use a pencil to mark the back side of the panel where it meets the cabinet corners.

Cut and secure cleats to filler panel

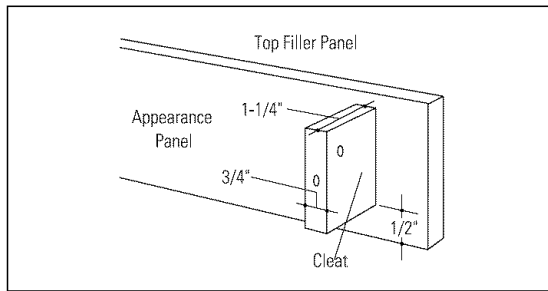

For the top filler panel:

- Cut 2 cleats out of 3/4" thick material, approximately 1-1/4" wide.
- Cut the cleats to a length leaving approximately 1/2" at the bottom of the appearance panel to attach the rail.
- Position the outside edge and top of the cleat against the corner pencil marks.
- Secure the cleat to the appearance panel with screws.

Note: The screws should be long enough to secure the cleats to the filler panel without penetrating the appearance side.

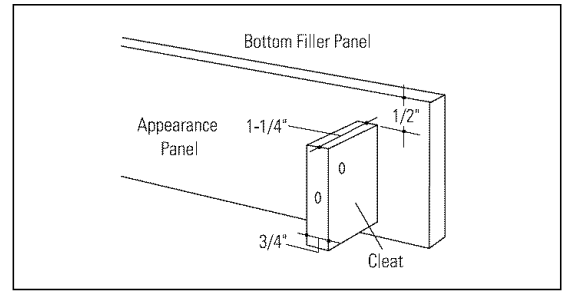

For the bottom filler panel:

- Cut 2 cleats out of 3/4" thick material, approximately 1-1/4" wide.
- Cut the cleats to a length leaving approximately 1/2" at the top of the filler panel to attach the rail.
- Position the outside edge and bottom of the cleat against the corner pencil marks.
- Secure the cleat to the appearance panel with screws.

Note: If appearance panel is very narrow, cleats can be attached to the rail.

Secure rail to appearance panel

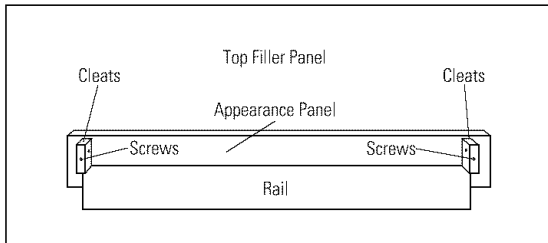

- Place rail against cleats and flush with the outside edges of the cleats. Secure with wood screws. If the appearance panel is very narrow, cleats can be attached to the rail.

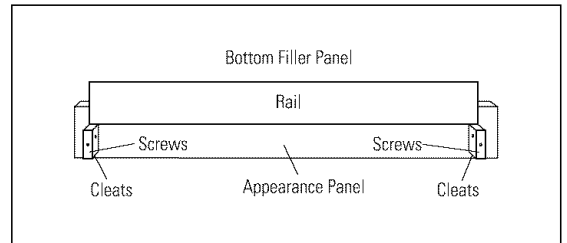

Note: The screws should be long enough to secure rail to the filler panel without penetrating the finished face of the filler panel.

Secure assembled filler panel to cabinet

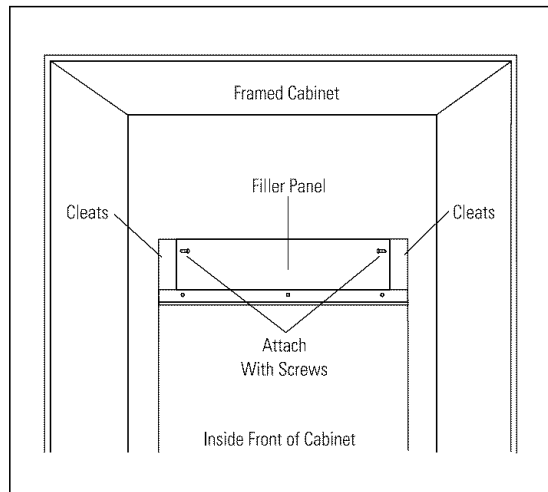

- Place filler panel in proper position. To attain proper relationship to adjacent drawers and doors

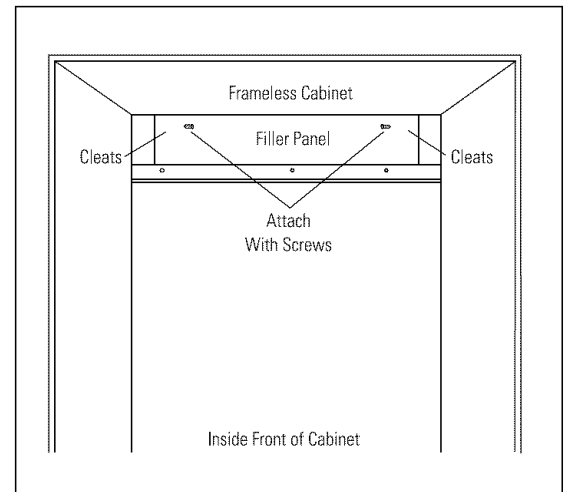

you may need to space the filler panel out from the cabinet face/edges using drawer bumpers or other spacers.

NOTE: While performing installations described in this book, safety glasses or goggles should be worn.

To obtain specific information concerning any Monogram product or service, call GE Answer Center® consumer information service at 800.626.2000—any time, day or night.

For Monogram local service in your area, call 1-800-444-1845.

NOTE: Product improvement is a continuing endeavor at General Electric. Therefore, materials, appearance and specifications are subject to change without notice.



Monogram.®

General Electric Company
Louisville, KY 40225

Pub. No. 49-8791
Dwg. No. 164D3333P046
© 1997 GE Appliances
(N.D. 521) 3/97