

# HOOVER®

# Slider™

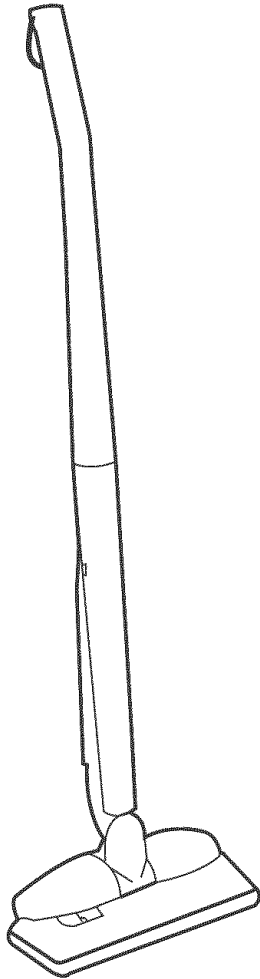

## Owner's Manual

English → pp. 1-6  
 Español → pág. 7-10  
 Français → p. 11-14



### Thank you for selecting a HOOVER product.

This cleaner was inspected and packaged carefully before being shipped from the factory. If you should happen to need assistance during assembly or operation call

**1-800-944-9200** for an automatic referral of authorized service outlet locations (U.S. only) or

1-330-499-9499 to speak with a representative in our Consumer Response Center.

**PLEASE DO NOT RETURN THIS PRODUCT TO THE STORE.**

### Fill in and retain

The model and serial number are located on the bottom of the cleaner. For your personal records, please enter the COMPLETE model and serial number in the spaces provided and retain this information.

Your cleaner is model \_\_\_\_\_

and has serial number \_\_\_\_\_

It is suggested that you attach your sales receipt to this owner's manual. Verification of date or purchase may be required for warranty service of your Hoover product.

## Important Safeguards!

When using an electrical appliance, always follow basic precautions, including the following:

**READ ALL INSTRUCTIONS BEFORE USING THIS APPLIANCE**

### Warning:

To reduce the risk of fire, electric shock or injury:

- Do not use outdoors or on wet surfaces.
- Close supervision is necessary when any appliance is used by or near children. Do not allow vacuum cleaner to be used as a toy or to run unattended at any time.
- Keep hair, loose clothing, fingers, feet and all parts of body away from openings, rotating agitator and other moving parts.
- Do not pick up anything that is burning or smoking, such as cigarettes, matches, or hot ashes.
- Do not use to pick up flammable or combustible liquids such as gasoline or use in areas where they may be present.
- Avoid picking up hard, sharp objects with the cleaner. They may damage the cleaner and the filter.
- Do not use without dirt cup in place. When picking up very fine materials such as powder, empty dirt cup often.
- Use extra care when cleaning on stairs.
- Do not put any object into openings. Do not use with any opening blocked; keep free of dust, lint, hair, or anything that may reduce air flow.
- The use of an extension cord is not recommended.
- Do not use charger with damaged cord or plug. If appliance is not working as it should, has been dropped, damaged, left outdoors, or dropped into water, take it to a Hoover Factory Service Center or Authorized Hoover Warranty Service Dealer (Depot).
- Use vacuum cleaner only for its intended use as described in the instructions. Use only attachments recommended by the Hoover Company; others may cause hazards.
- Do not incinerate this appliance even if it is severely damaged. The batteries can explode in a fire.
- Do not unplug by pulling on cord. To unplug, grasp the charger, not the cord. Never handle plug or charger with wet hands.
- Use only the charger supplied by the manufacturer to recharge this appliance.
- Charge indoors only.

### Review this manual before operating cleaner

#### Index

Battery disposal.....	4
Charging .....	3
Cleaner description and unpacking.....	2
How to assemble .....	3
How to use .....	3
If you have a problem.....	5
Important safeguards .....	1
Lubrication .....	5
Maintenance	
Brush roll .....	4
Dirt cup.....	3
Storage .....	4
Service .....	6
Warranty.....	6



## Save these instructions!

## 5. On-Off switch

### Questions or Concerns?

The Hoover Company wants to quickly resolve any concerns about your cleaner or questions regarding its use. Look on the list provided with the product for your local Hoover Factory Service Center or in the yellow pages under "Vacuum Cleaners - Household" for the nearest Authorized Hoover Warranty

Service Dealer (Depot) or:  
Visit us online at [www.hoover.com](http://www.hoover.com) to find the service outlet nearest you (click on the "Service" button) OR

Call **1-800-944-9200** for an automated referral of authorized service outlet locations (U.S. only) OR

Call 1-330-499-9499 to speak with a representative in the Hoover Consumer Response Center.

**DO NOT RETURN THIS PRODUCT TO THE STORE OR SEND IT TO**

## Unpacking

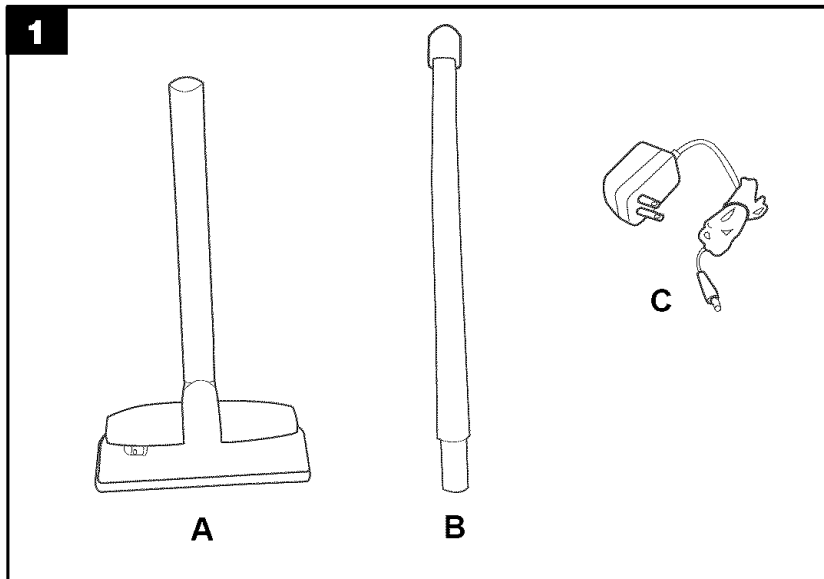

**Unpack the cleaner from the carton and identify the parts shown. Remove and dispose of**

**cardboard packing.**  
**A. Compact cleaner**  
**B. Handle**  
**C. Charger**

**NOTE: Be sure to charge your vacuum cleaner 16 hours before initial use.**

Batteries may lose charge during shipping. Make sure the switch is in the **OFF** position before charging.

**This cleaner is intended for**

## Cleaner descriptions

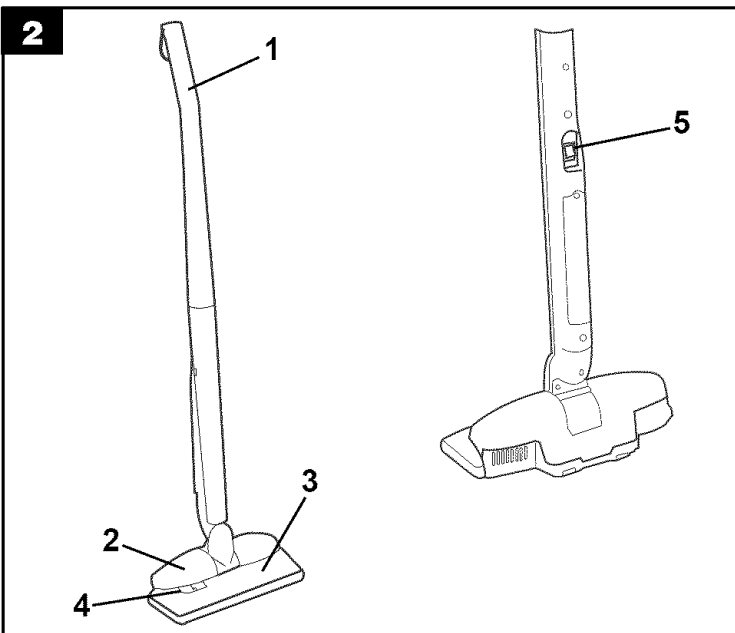

**household use.**

The assembled cleaner will look like the drawing.

1. Handle
2. Dirt cup
3. Nozzle with brush roll
4. Dirt cup latch

## Charging

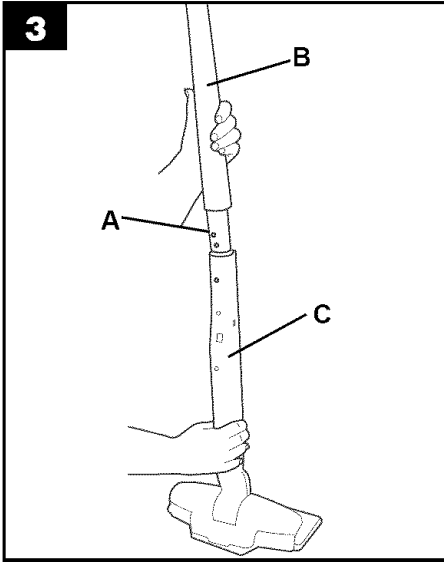

### Attach handle

With upper handle button (A) towards back of cleaner, push

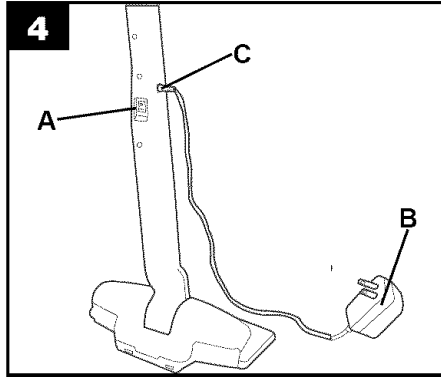

upper handle (B) into lower handle (C) until button snaps into position. With switch (A) in **OFF** position, plug charger (B) into 110/120 volt electrical outlet.

Firmly press charger end into cleaner receptacle (C), located on the side of the handle. **Press firmly on cleaner to ensure that end of cord is fully connected.** Your cleaner will begin charging. It is designed to be

stored on charge and ready for use at all times.

**Charge batteries for 16 hours before initial use.** If performance drops to an unacceptable level during cleaning, refer to the problem chart in "Maintenance" section.

#### NOTE:

- It is normal for the charger to feel warm when the battery is charging. Never charge batteries in temperatures above 100° F or below 32° F.

- Charging light illuminates when cleaner is charging.

- The cleaner can be on a constant charge so it is always ready for use.

**Make sure it is in OFF position before charging.** However, if the cleaner will not be used for several weeks at a time, unplugging it is recommended.

**Do not use an outlet which is con-**

## How to use

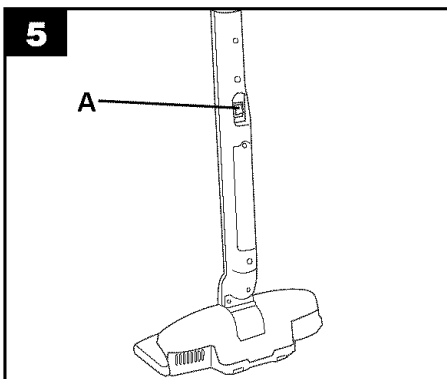

**Controlled with a wall switch for charging your cleaner. ON-OFF switch**

The switch has 2 positions.

Push switch (A) down to **ON** position and lower handle to operating position to turn the unit on. For convenience, the unit will stop running when the handle is placed in the upright position.

When cleaning is finished, it is rec-

## Maintenance

ommended that the switch be turned to the **OFF** position for storage.

Familiarize yourself with these home maintenance tasks as proper use and care of your cleaner will ensure continued cleaning effectiveness.

### The dirt cup

Empty dirt cup after each use. It

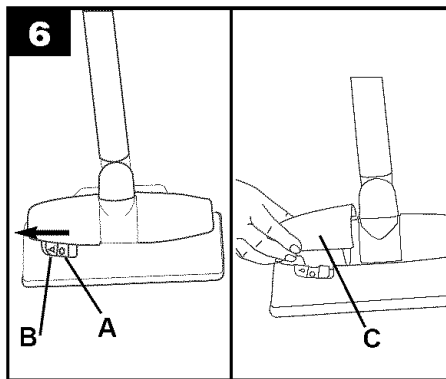

may be cleaned with a damp cloth. Make sure cup is thoroughly dry before repositioning on cleaner.

### How to empty

**Turn switch to OFF position.**

Press button (A) and slide latch (B)

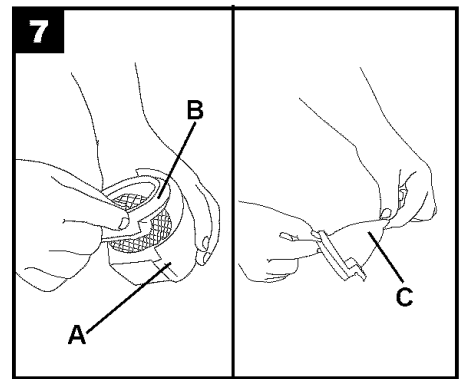

towards outside of cleaner. Rotate dirt cup (C) toward back of cleaner. While holding dirt cup (A), grasp filter frame (B) and lift out filter.

Empty dirt cup.

Pull middle section (C) of filter out of filter frame. To remove debris from filter, tap it on a hard surface or brush it with a soft brush.

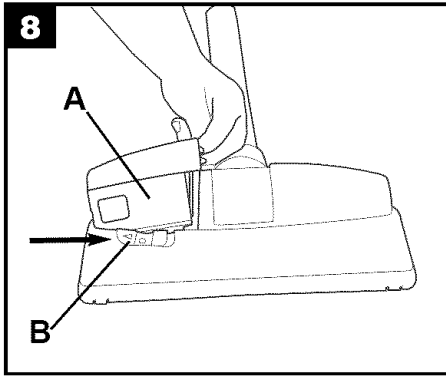

Push middle section of filter back into filter frame. Replace filter into dirt cup.

Replace dirt cup to cleaner by sitting cup into dirt cup cavity with the black flap (A) on the dirt inlet facing the front of the unit. Then pivot the

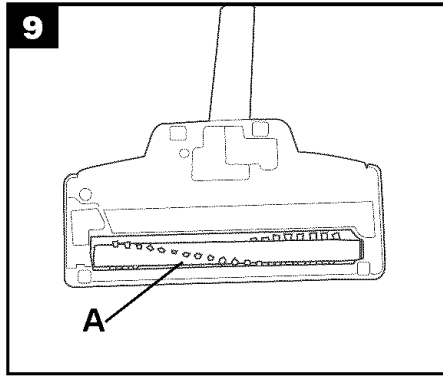

dirt cup forward until a snap is felt. Lock in place by sliding the latch (B) toward the center of the nozzle.

**The brush roll**

**How to clean**

Turn switch to OFF position.

To maintain cleaning effectiveness,

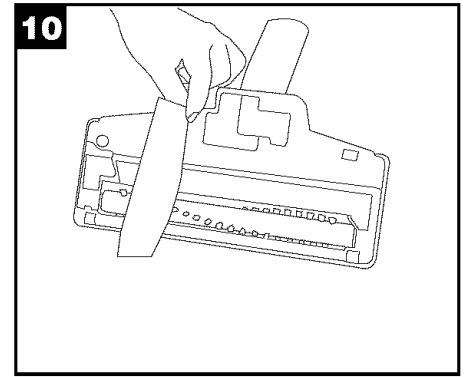

periodically remove lint, strings, etc. from the brush roll (A) located on the underneath side of the nozzle.

**When to replace**

Replace the brush roll when the brushes do not touch the edge of a card as it is moved across the opening on the bottom of the nozzle.

A new brush roll can be installed by

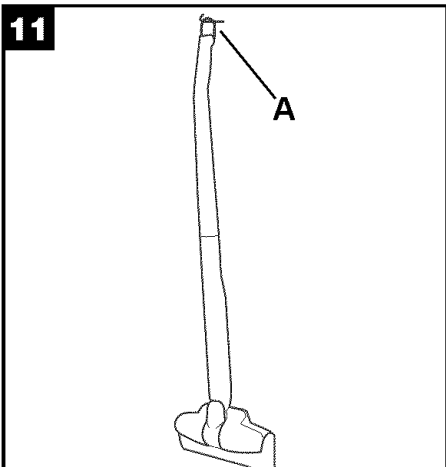

**Storage**

The cleaner may be conveniently hung from the hook (A) located on the top of the upper handle.

Turn switch to OFF position before hanging.

your local Authorized Hoover Dealer (Depot) or at a Hoover Factory Service Center.

**Battery recycling**

Your cleaner contains nickel cadmium batteries.

When these batteries no longer recharge, they must be removed from the cleaner and disposed of properly in accordance with state laws as described in Item 14.

**How to remove battery pack**

**NOTE:** Do not remove the batteries to recharge them. The batteries should only be removed if they no

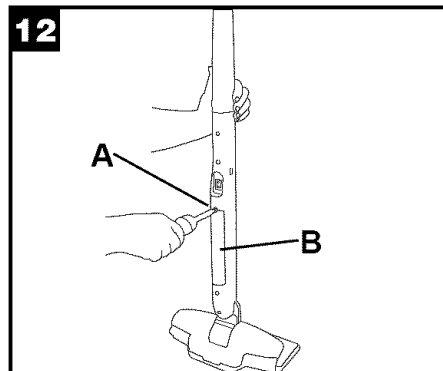

longer recharge and you plan to replace the batteries or dispose of the cleaner.

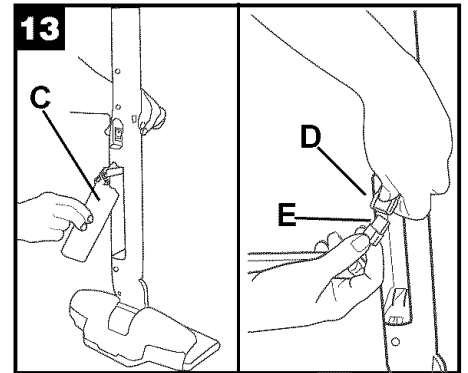

Using a Phillips screwdriver, remove screw (A) on battery door (B). Remove door.

Remove battery pack (C) from unit. To disconnect battery pack from terminal, push down on tab (D) and pull connector (E) straight out.

To install a new battery pack, push

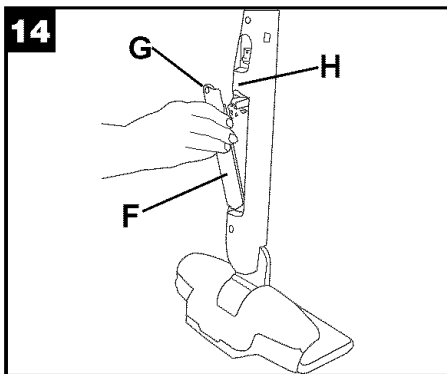
**14**

connector straight in until you hear a click. Return battery pack and terminal into unit.

Replace battery door by first inserting tab (F) on bottom of door and positioning hole (G) on door with hole (H) on unit. Replace screw and tighten with screwdriver



Dispose of battery pack in accordance with your state's laws.

The EPA certified RBRC® Battery Recycling Seal on the nickel-cadmium (Ni-Cd) battery indicates The Hoover Company is voluntarily participating in an industry program to collect and recycle these batteries at the end of their useful life, when taken out of service in the United States or Canada. The RBRC® program provides a convenient alternative to placing used Ni-Cad batteries into the trash or the municipal waste stream, which may be illegal in your area. Please call 1-800-8-BATTERY™ for information on Ni-Cd battery recycling and disposal bans/restrictions in your area.

The Hoover Company's involvement in this program is part of our commitment to preserving our environment and conserving our natural resources.

## Service

To obtain approved Hoover Service and Genuine HOOVER parts, locate the nearest Hoover Factory Service Center or Authorized Hoover Warranty Service Dealer (Depot) by:

- checking the Yellow Pages under "Vacuum Cleaners-Household" OR -
- checking the list of Factory Service Centers provided with this cleaner OR -
- checking the Service section of The Hoover Company on-line at [www.hoover.com](http://www.hoover.com) OR -
- calling **1-800-944-9200** for an automated referral of authorized service outlet location (U.S. only).

Do not send your cleaner to The Hoover Company in North Canton for service, this will only result in delay.

If further assistance is needed, contact The Hoover Company Consumer Response Center, North Canton, Ohio 44720, Phone: 1-330-499-9499.

In Canada, contact Hoover Canada, Burlington, Ontario L7R 4A8, Phone: 1-800-263-6376.

Always identify your cleaner by the complete model number when requesting information or ordering parts. (The model number appears on the bottom of the cleaner.)

## Lubrication

Lubrication is not necessary since the motor and brush roll bearings are permanently lubricated.

If desired, you may contact your local Hoover Factory Service Center for battery pack replacement.

## If you have a problem

If a minor problem occurs, it usually can be solved quite easily when the

### Problem: Cleaner won't run

list below.

#### Possible Cause

Possible solution

- **Charger not firmly plugged in**
- *Plug charger in firmly*
- **Battery not charged**
- *Recharge battery making sure cleaner is fully connected to end of cord*
- **No voltage in wall plug**

### Problem: Cleaner won't pick up

- *Check fuse or breaker*
- **Blown fuse or tripped breaker**
- *Replace fuse/ reset breaker*

### Problem: Charging light not lit when plugged in

#### Possible Cause

Possible solution

- **Cleaner not firmly plugged in**
- *Plug charger in firmly*

## **Full One Year Warranty (Domestic Use)**

Your HOOVER® appliance is warranted in normal household use, in accordance with the Owner's Manual against original defects in material and workmanship for a period of one full year from date of purchase. This warranty provides, at no cost to you, all labor and parts to place this appliance in correct operating condition during the warranted period. This warranty applies when the appliance is purchased in the United States including its territories and possessions, or in Canada or from a U. S. Military Exchange. Appliances purchased elsewhere are covered by a limited one year warranty which covers the cost of parts only. This warranty does not apply if the appliance is used in a commercial or rental application.

This warranty only applies when the product is in use in the country or territory in which it is purchased.

Warranty service can only be obtained by presenting the appliance to one of the following authorized warranty service outlets. Proof of purchase will be required before service is rendered.

1. Hoover Factory Service Centers.
2. Hoover Authorized Warranty Service Dealers (Depots).

**For an automated referral of authorized service outlets in the U.S.A., phone 1-800-944-9200 OR**

**visit The Hoover Company on-line at [www.hoover.com](http://www.hoover.com)**

This warranty does not cover pick up, delivery, or house calls; however, if you mail your appliance to a Hoover Factory Service Center for warranty service, transportation will be paid one way.

While this warranty gives you specific legal rights, you may also have other rights which vary from state to state.

If further assistance is needed, or if there are questions concerning this warranty or the availability of warranty service outlets, write or phone the Consumer Response Center, The Hoover Company, 101 East Maple St., North Canton, Ohio 44720. Phone (330) 499-9499.

In Canada, contact Hoover Canada, Burlington, Ontario L7R 4A8, Phone: 1-800-263-6376.