

Installation Instructions

If you have questions, call 800.626.2000 or visit our website at: www.monogram.com

Wine Reserve

ZDWT240

and

Beverage Center

ZDBT240

Design Guide

With Installation Instructions



Monogram®

Safety Information

BEFORE YOU BEGIN:

Read these instructions completely and carefully.

IMPORTANT – Save these instructions for local inspector’s use.

IMPORTANT – Observe all governing codes and ordinances.

Note to Installer – Be sure to leave these instructions with the Consumer.

Note to Consumer – Keep these instructions with your Owner’s Manual for future reference.

WARNING – This appliance must be properly grounded. See “Grounding”, page 4.

AVERTISSEMENT –
Cet appareil doit être correctement mise à la terre. Consulter <<Mise à la terre>>, page 4.

If you received a damaged wine reserve or beverage center, you should immediately contact your dealer or builder.

Skill Level – Installation requires basic mechanical skills. Proper installation is the responsibility of the installer. Product failure due to improper installation is not covered under the GE Appliance Warranty.

WARNINGS:

- Use this appliance only for its intended purpose.
- Immediately repair or replace electrical service cords that become frayed or damaged.
- Unplug the unit before cleaning or making repairs.
- Repairs should be made by a qualified service technician.

AVERTISSEMENT :

- Il ne faut utiliser cet appareil que pour l’usage pour lequel il a été construit.
- Il faut réparer ou remplacer immédiatement tout cordon d’alimentation électrique effiloché ou endommagé.
- Débrancher le bar ou le réfrigérateur à vin avant le nettoyage ou toute intervention.
- Les réparations doivent être faites par un technicien qualifié.

For Monogram local service in your area, call
1.800.444.1845

For Monogram service in Canada, call
1.888.880.3030

For Monogram Parts and Accessories, call
1.800.626.2002.

www.monogram.com

CONTENTS

Design Guide

The Installation Space	3
Product Clearances	3

Installation Instructions

Tools, Hardware	4
Grounding the Product	4
Staining Wood Drawer Fronts	4
Step 1, Remove Packaging	4
Step 2, Leveling	5

Step 3, Connect Power	5
Step 4, Slide Product into Cutout	5
Step 5, Change the Toekick	5
Step 6, Set Temperature Controls	5

Design Guide

THE INSTALLATION SPACE

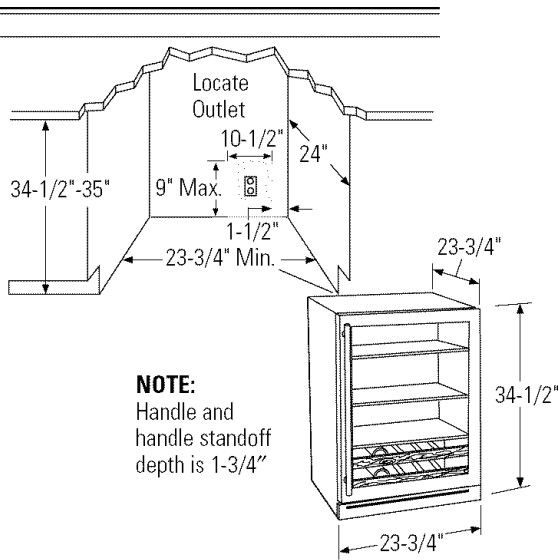

NOTE:
Handle and handle standoff depth is 1-3/4"

The cutout depth should be 24"

The cutout dimensions shown allow for a full door swing and access to the pull-out racks when installed as a built-in in standard 24" deep cabinets.

- The wine reserve and beverage center can be installed freestanding.
- If installing between frameless cabinets, a 1/2" wide filler strip or side panel may be needed on hinge side. The filler strip will act as a spacer between the case and adjacent cabinet door swing. The width of the opening must include the filler panels.

NOTE: The door should protrude 1" beyond the surrounding cabinets.

Additional Specifications

- A 120 volt 60Hz., 15 or 20 amp power supply is required. An individual properly grounded branch circuit or circuit breaker is recommended. Install a properly grounded 3-prong electrical receptacle recessed into the back wall as shown. Electrical must be located on rear wall as shown. **NOTE:** GFI (ground fault interrupter) is not recommended.

PRODUCT CLEARANCES

The wine reserve and beverage center is factory set for a 110° door swing.

When installed in a corner:

- Allow 4" min. clearance on the hinge side for the 90° door swing and to allow racks to slide out.
- Allow 10" minimum clearance on the hinge side for a full 110° door swing.

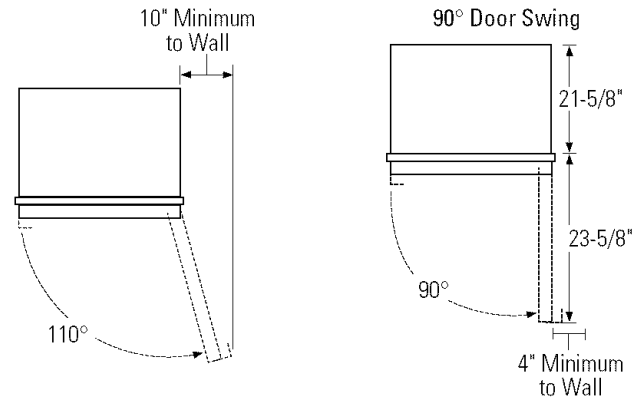

Choose the location:

- These products may be closed in on the top and three sides as long as the front is unobstructed for air circulation and proper access to the door.
- Do not install these products where the temperature will go below 55°F (13°C) or above 90°F (32°C).
- Do not install where it will be subject to direct sunlight, heat or moisture.
- These products are not designed to be stacked one over the other.

Black or Stainless Steel Toekick Options

- These products are shipped with a black toekick installed. An optional stainless steel toekick is also supplied with each product. For shipping purposes, the stainless steel toekick is secured to the back or inside the unit.

SIDE-BY-SIDE INSTALLATIONS

Increase storage capacity by installing two Monogram beverage centers or wine reserves together. Or, for a complete refreshment center, install any two of these units together.

- A side-by-side installation requires at least a 47-1/2" wide opening. No trim kits required.
- Products must operate from separate, properly grounded receptacles.

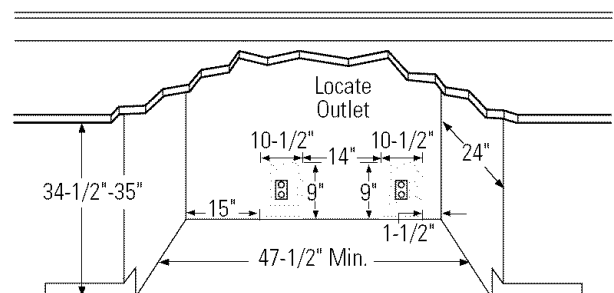

Installation Instructions

TOOLS REQUIRED

- #2 Phillips screwdriver
- Adjustable wrench

PARTS SUPPLIED

- Optional stainless steel toekick with screws and spacers

GROUNDING THE WINE CHILLER, WINE RESERVE AND BEVERAGE CENTER

IMPORTANT — Please read carefully.

FOR PERSONAL SAFETY, THIS APPLIANCE MUST BE PROPERLY GROUNDED.

The power cord of this appliance is equipped with a three-prong (grounding) plug which mates with a standard three-prong (grounding) wall receptacle to minimize the possibility of electric shock hazard from this appliance.

Have the wall outlet and circuit checked by a qualified electrician to make sure the outlet is properly grounded.

Where a standard 2-prong wall outlet is encountered, it is your personal responsibility and obligation to have it replaced with a properly grounded 3-prong wall outlet.

DO NOT, UNDER ANY CIRCUMSTANCES, CUT OR REMOVE THE THIRD (GROUND) PRONG FROM THE POWER CORD.

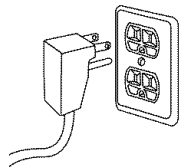

DO NOT USE AN ADAPTER PLUG TO CONNECT THE REFRIGERATOR TO A 2-PRONG OUTLET.

DO NOT USE AN EXTENSION CORD WITH THIS APPLIANCE.

STAINING WOOD DRAWER FRONTS

The drawer fronts are unfinished cherry wood. During use, oil from hands may accumulate and stain the wood.

- The drawer fronts may be stained and sealed to match adjacent cabinetry. The tinted glass will make the stained wood appear darker. A true color match can be seen only when the door is opened.
- Apply the stain and sealer according to the manufacturer's instructions. To avoid unpleasant odor, keep the door open to ventilate and allow the stain/sealer to dry completely before using the product.

STEP 1 REMOVE PACKAGING

- Remove corner blocks and foam drawer stops.
- Remove all packing material, tape and protective plastic coverings.
- Remove stainless steel toekick taped to the back or inside of the unit.

CAUTION: Small objects are a choke hazard for children. Remove and discard any parts not used.

MISE EN GARDE : Les petits objets peuvent étrangler les enfants. Il faut jeter toutes les pièces qui ne sont pas utilisées.

Installation Instructions

STEP 2 LEVEL

- Use an adjustable wrench to turn the leveling legs and raise or lower the product.
- Adjust carefully; the product should be level and plumb with cabinetry, and should align with adjacent toe-kick height.

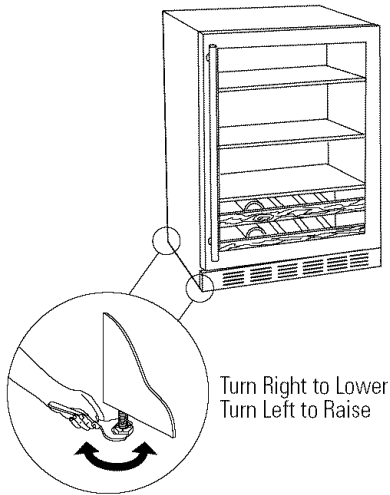

STEP 3 CONNECT POWER

- Connect power cord plug to a properly grounded receptacle.
- Check to make sure power is on by opening the door to see if interior light turns on.

STEP 4 SLIDE PRODUCT INTO THE CUTOUT

WARNING: Do not apply pressure or push against the glass door when moving or installing these products. Pressure against the glass door will cause damage.

AVERTISSEMENT : Ne poussez jamais et ne mettez jamais de pression sur la porte en verre quand vous déplacez ou installez ces produits. Toute pression sur le verre occasionnera des dommages.

- Carefully slide the unit into the opening. Be careful not to entangle power cord.
- Make certain that the door protrudes 1" beyond the surrounding cabinets.
- Check again to be sure the unit is level.

STEP 5 CHANGE THE TOEKICK

- The stainless steel toekick is secured to the back of the product or inside.
- The toekick has a cutout on the left and right sides.

Remove the plug on the left side and reinstall on the right side. If you choose to install the stainless steel toekick, reinstall the plug on the right side of that toekick.

- Install original screws and spacers or screws and spacers supplied with the stainless steel toekick. Install screws through the spacer standoff, toekick and into the base as shown.

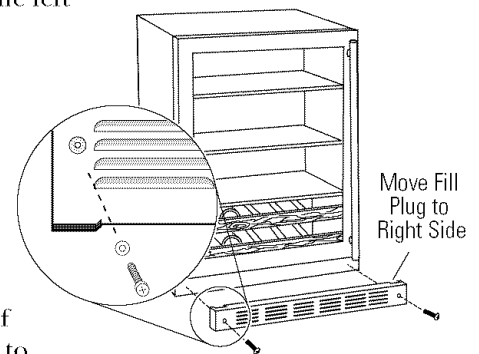

STEP 6 SET TEMPERATURE CONTROLS

- The temperature controls are preset. Refer to the Owner's Manual for more information. Allow 24 hours for temperature to stabilize.

Notes

Notes

Note: While performing installations described in this book, safety glasses or goggles should be worn.

For Monogram® local service in your area, call 1.800.444.1845.

Note: Product improvement is a continuing endeavor at General Electric. Therefore, materials, appearance and specifications are subject to change without notice.

Pub. No. 31-46065
Dwg. No. 197D6374P001

11-04 JR

Printed in Slovenia



Monogram.®

*GE Consumer & Industrial
Louisville, KY 40225*

©2004 GE Company