

WEIDER® 9400 PRO

USER'S MANUAL

Model No. WESY39311

Serial No. _____

Write the serial number in the space above for reference.

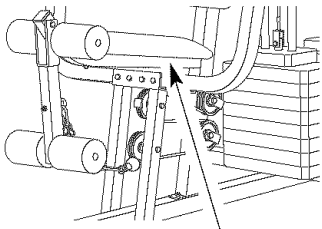

Serial Number Decal (Under Seat)

QUESTIONS?

As a manufacturer, we are committed to providing complete customer satisfaction. If you have questions, or if there are missing parts, we will guarantee complete satisfaction through assistance from our factory.

TO AVOID UNNECESSARY DELAYS, PLEASE CALL DIRECT TO OUR TOLL-FREE CUSTOMER HOT LINE. The trained technicians on our customer hot line will provide immediate assistance, free of charge to you.

CUSTOMER HOT LINE:

1-800-999-3756

Mon.–Fri., 6 a.m.–6 p.m. MST

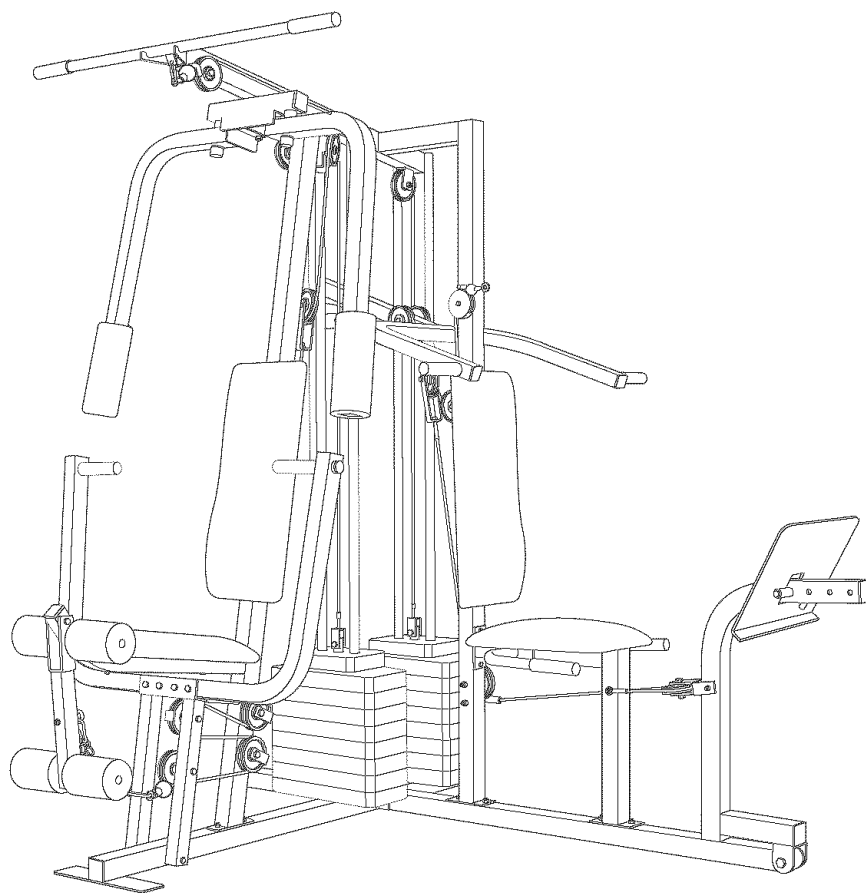

CAUTION

Read all precautions and instructions in this manual before using this equipment. Save this manual for future reference.



Visit our website at

www.weiderfitness.com

*new products, prizes,
fitness tips, and much more!*

TABLE OF CONTENTS

IMPORTANT PRECAUTIONS3
BEFORE YOU BEGIN4
ASSEMBLY5
ADJUSTMENTS21
WEIGHT RESISTANCE CHART23
TROUBLE-SHOOTING AND MAINTENANCE24
CABLE DIAGRAMS25
ORDERING REPLACEMENT PARTSBack Cover
LIMITED WARRANTYBack Cover

Note: A PART IDENTIFICATION CHART and a PART LIST/EXPLODED DRAWING are attached at the center of this manual. Remove the PART IDENTIFICATION CHART and the PART LIST/EXPLODED DRAWING before beginning assembly.

IMPORTANT PRECAUTIONS

▲WARNING: To reduce the risk of serious injury, read the following important precautions before using the weight system.

1. Read all instructions in this manual and in the accompanying literature before using the weight system. Use the weight system only as described in this manual.
2. It is the responsibility of the owner to ensure that all users of the weight system are adequately informed of all precautions.
3. The weight system is intended for home use only. Do not use the weight system in any commercial, rental, or institutional setting.
4. Use the weight system only on a level surface. Cover the floor beneath the weight system to protect the floor.
5. Make sure all parts are properly tightened each time you use the weight system. Replace any worn parts immediately.
6. Keep children under the age of 12 and pets away from the weight system at all times.
7. Always wear athletic shoes for foot protection.
8. Keep hands and feet away from moving parts.
9. Never release the press arm, butterfly arms, military press arm, leg lever, leg press plate, lat bar or nylon strap while weights are raised. The weights will fall with great force.
10. *Always disconnect the lat bar from the weight system when performing an exercise that does not use the lat bar.*
11. Keep your hands away from the leg press upright when the military press arm is being used. Your hand could become pinched between the leg press upright and military press arm.
12. Always stand on a foot plate when performing an exercise that could cause the weight system to tip.
13. The weight system is designed to support a maximum user weight of 250 pounds.
14. Make sure that the cables remain on the pulleys at all times. If the cables bind while you are exercising, stop immediately and make sure that the cables are on all of the pulleys.
15. If you feel pain or dizziness at any time while exercising, stop immediately and begin cooling down.
16. The decals shown here have been placed on the weight system in the locations shown on page 4. If a decal is missing, or if it is not legible, please call our Customer Service Department toll-free at 1-800-999-3756, Monday through Friday, 6 a.m. until 6 p.m. Mountain Time, to order a free replacement decal. Place the decal on the weight system in the location shown.

Warning Decal No. 1

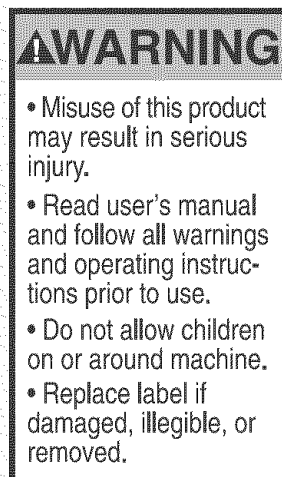

Warning Decal No. 3



Warning Decal No. 2

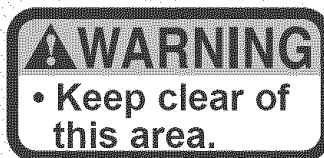

▲WARNING: Before beginning this or any exercise program, consult your physician. This is especially important for persons over the age of 35 or persons with pre-existing health problems. Read all instructions before using. ICON assumes no responsibility for personal injury or property damage sustained by or through the use of this product.

BEFORE YOU BEGIN

Thank you for selecting the versatile WEIDER® PRO 9400 weight system. The PRO 9400 offers a selection of weight stations designed to develop every major muscle group of the body. Whether your goal is to tone your body, build dramatic muscle size and strength, or improve your cardiovascular system, the PRO 9400 will help you to achieve the specific results you want.

For your benefit, read this manual carefully before using the weight system. If you have additional questions, please call our Customer Service

Department toll-free at 1-800-999-3756, Monday through Friday, 6 a.m. until 6 p.m. Mountain Time (excluding holidays). To help us assist you, please note the product model number and serial number before calling. The model number is WESY39311. The serial number can be found on a decal attached to the weight system (see the front cover of this manual).

Before reading further, please review the drawing below and familiarize yourself with the parts that are labeled.

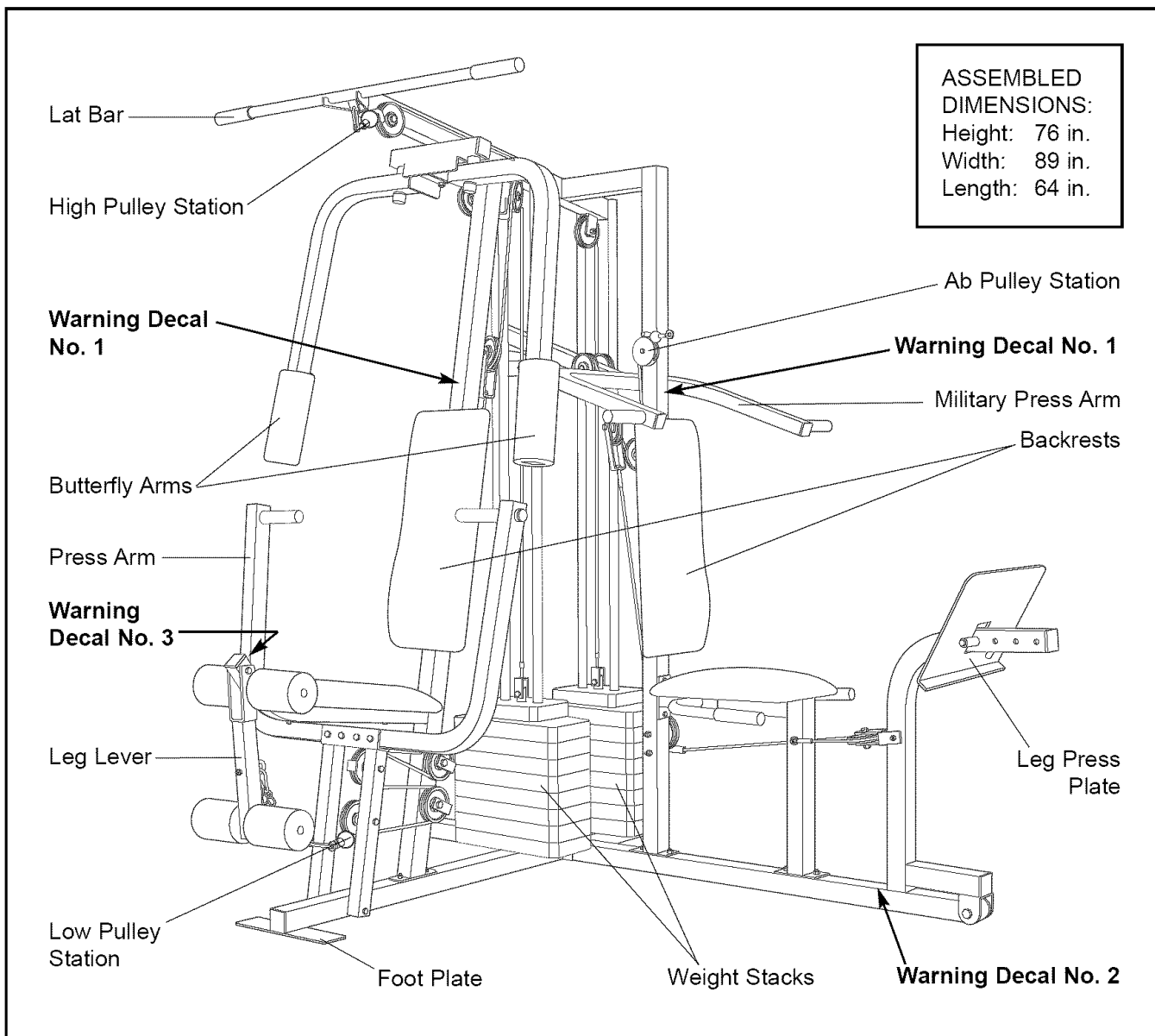



ASSEMBLY

Before beginning assembly, carefully read the following information and instructions:

- Due to the many features of the weight system, assembly will require several hours. By setting aside plenty of time and by deciding to make the task enjoyable, assembly will go smoothly. You may want to assemble the weight system over a couple of evenings.
- Place all parts of the weight system in a cleared area and remove the packing materials; do not dispose of the packing materials until assembly is completed.
- Assembly is divided into four stages: 1) frame assembly, 2) press and butterfly arm assembly, 3) cable and pulley assembly, and 4) seat and backrest assembly. The hardware for each stage is packaged separately.
- Wait until you begin each assembly stage to open the parts bag labeled for that assembly stage.
- For help identifying the small parts used in assembly, **use the PART IDENTIFICATION CHART located in the center of this manual.** Note: Some small parts may have been pre-attached for shipping. If a part is not in the parts bag, check to see if it has been pre-attached.
- Tighten all parts as you assemble them, unless instructed to do otherwise.

- Assembly requires two persons. For your convenience and safety, assemble the weight system with the help of another person.
- As you assemble the weight system, be sure that all parts are oriented as shown in the drawings.

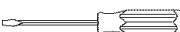
THE FOLLOWING TOOLS (NOT INCLUDED) ARE REQUIRED FOR ASSEMBLY:

- **Two (2) adjustable wrenches** 
- **One (1) standard screwdriver** 
- **One (1) phillips screwdriver** 
- **One (1) rubber mallet** 
- **Lubricant, such as grease or petroleum jelly, and soapy water will also be needed.**
- Assembly will be more convenient if you have the following tools: A socket set, a set of open-end or closed-end wrenches, or a set of ratchet wrenches.

Questions?

- If you have questions after reading the assembly instructions, please call our Customer Service Department toll-free at **1-800-999-3756**, Monday through Friday, 6 a.m. until 6 p.m. Mountain Time.

FRAME ASSEMBLY

1. **Before beginning, be sure that you have read and understand the information in the box above.**

Locate and open the parts bag labeled "FRAME ASSEMBLY."

Press two 2" Square Outer Caps (51) onto the indicated locations on the Stabilizer (5). Press a 2" Square Inner Cap (27) into the end of the Base (4).

Insert six 5/16" x 2 1/2" Carriage Bolts (1) up through the Stabilizer (5). Insert two 5/16" x 2 1/2" Carriage Bolts up through the Base (4).

Attach the Base (4) to the Stabilizer (5) with two 5/16" x 2 3/4" Bolts (11), two 5/16" Washers (8), and two 5/16" Nylon Locknuts (3). **Do not tighten the Nylon Locknuts yet.**

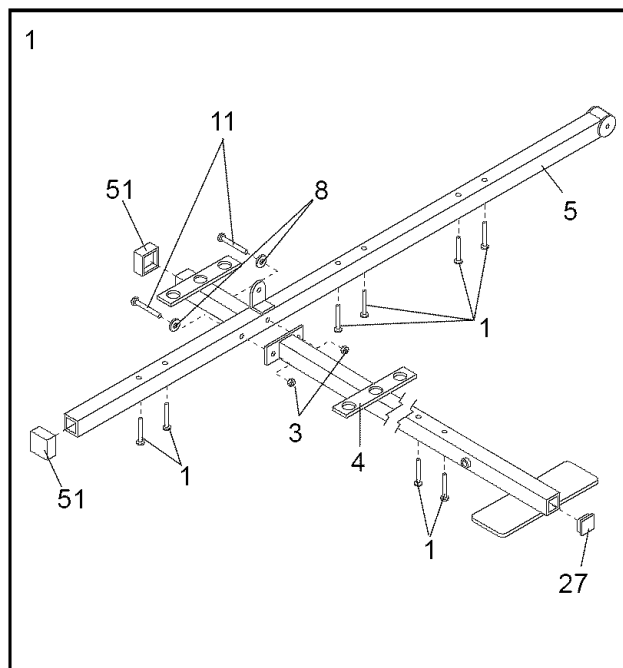

2. Slide the Rear Upright (74) and the Leg Press Upright (56) onto the indicated 5/16" x 2 1/2" Carriage Bolts (1) in the Stabilizer (5). **The high side of the brackets on the Rear Upright and Leg Press Upright should be on the side shown.** Hand tighten four 5/16" Nylon Locknuts (3) onto the Carriage Bolts. **Do not tighten the Nylon Locknuts yet.**

Press a 2" Square Inner Cap (27) into the Leg Press Upright (56). Press a 2" Square Inner Cap (27) into the Rear Upright (74).

Attach the Rubber Bumper (91) to the Leg Press Upright (56) with the #8 x 1/2" Self-tapping Screw (87).

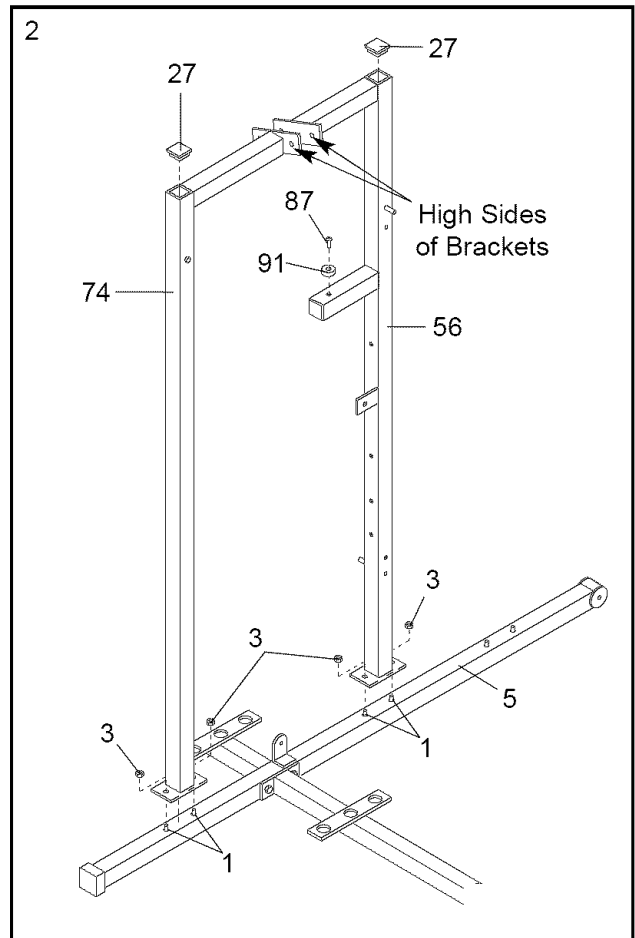

3. Slide the Front Upright (42) onto the 5/16" x 2 1/2" Carriage Bolts (1) in the Base (4). Hand tighten a 5/16" Nylon Locknut (3) onto each Carriage Bolt. **Do not tighten the Nylon Locknuts yet.**

Press a 1" Square Inner Cap (6) into the Front Upright (42).

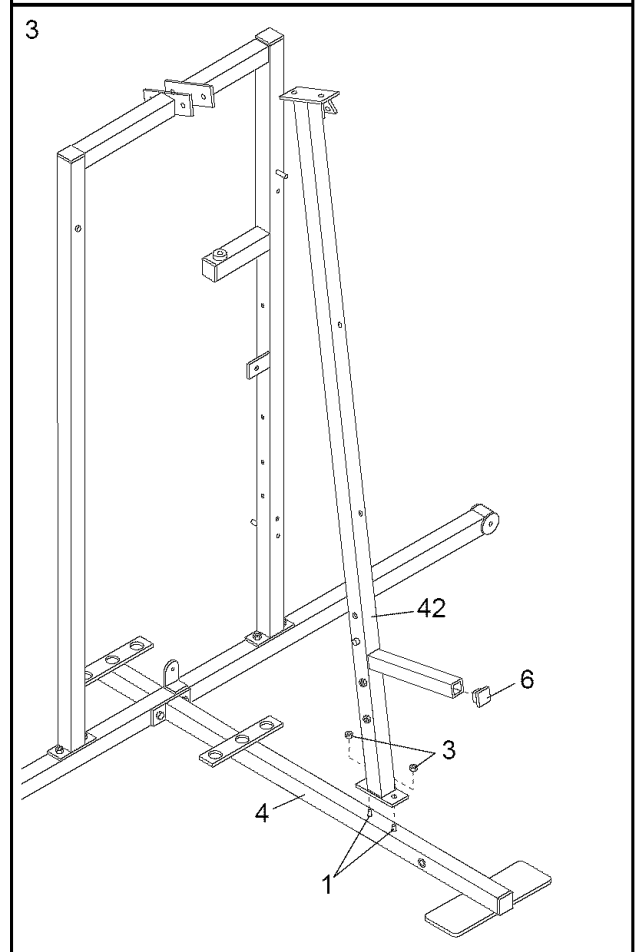

- Press a 2" Square Inner Cap (27) into the end of the Top Frame (55). Press a 1 3/4" Square Inner Cap (44) into each end of the crossbar on the Top Frame. Press two Round Inner Caps (75) into the top of the crossbar.

Attach the Top Frame (55) to the Rear Upright (74) and the Leg Press Upright (56) with two 5/16" x 2 3/4" Bolts (11) and two 5/16" Nylon Locknuts (3).

Attach the Top Frame (55) to the Front Upright (42) with two 5/16" x 2 3/4" Bolts (11), two 5/16" Washers (8), and two 5/16" Nylon Locknuts (3).

Do not tighten the 5/16" Nylon Locknuts (3) yet.

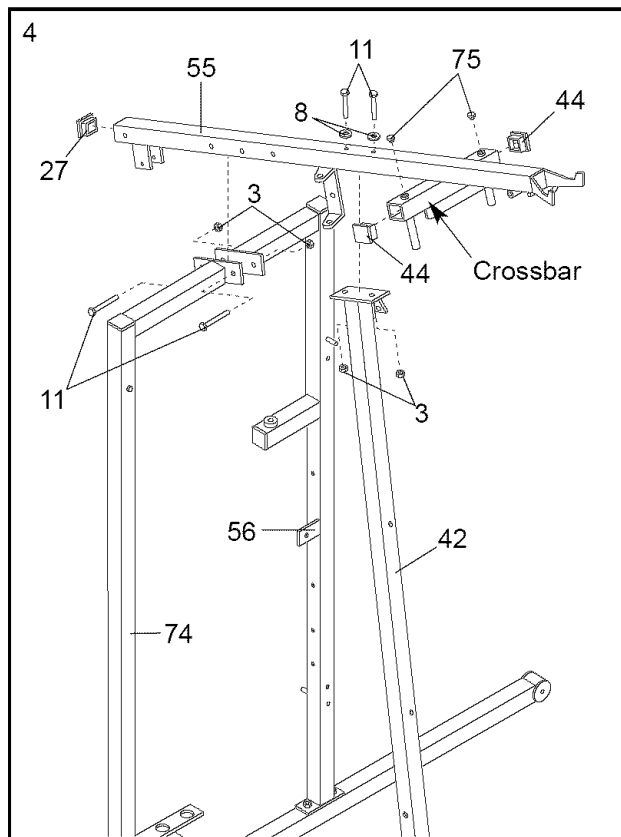

- Slide the Leg Press Seat Frame (79) onto the indicated 5/16" x 2 1/2" Carriage Bolts (1) in the Stabilizer (5). Hand tighten two 5/16" Nylon Locknuts (3) onto the Carriage Bolts.

Attach the other end of the Leg Press Seat Frame (79) to the Leg Press Upright (56) with two 5/16" x 2 3/4" Bolts (11), two 5/16" Washers (8), and two 5/16" Nylon Locknuts (3).

Attach the Handle (82) to the Leg Press Seat Frame (79) with two 5/16" x 2 1/2" Carriage Bolts (1) and two 5/16" Nylon Locknuts (3).

Tighten all 5/16" Nylon Locknuts (3) used in steps 1-5.

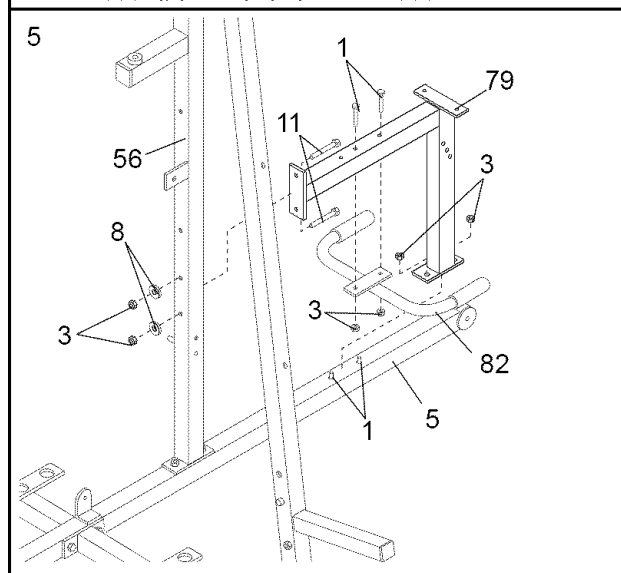

- Set two Weight Bumpers (19) on the bracket on the Base (4) as shown. Set two Weight Bumpers on the bracket on the Stabilizer (5).

Stack eight Weights (25) onto each set of Weight Bumpers (19). **Be sure that the pin grooves are on the indicated side of each stack of Weights.**

Be careful not to tip either stack of Weights (25) until step 8 is complete.

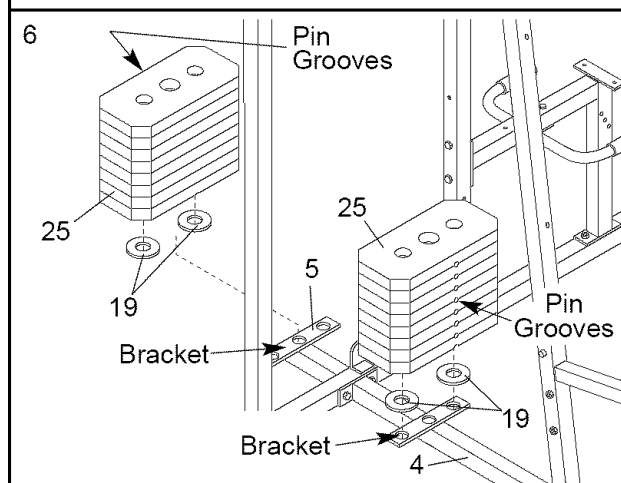

7. Press a Weight Tube Bumper (64) into the end of a Weight Tube (63). Insert the Weight Tube into the front stack of Weights (25). **Be sure that the pin on the Weight Tube is sitting in the pin grooves in the top Weight.**

Lubricate the inside of the holes in the Top Weight (65). Set the Top Weight onto the front stack of Weights (25). Insert both Long Weight Guides (62) into the stack of Weights. **Be sure that the holes in the Weight Guides are at the top, as shown.**

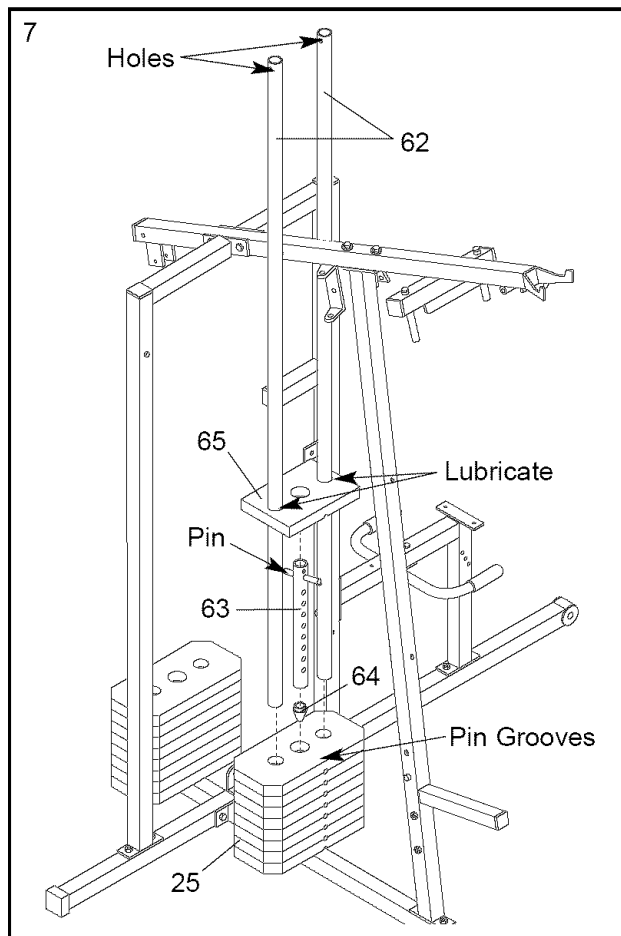

8. Press a Weight Tube Bumper (64) into the end of the other Weight Tube (63). Insert the Weight Tube into the rear stack of Weights (25). **Be sure that the pin on the Weight Tube is sitting in the pin grooves in the top Weight.**

Lubricate the inside of the holes in the other Top Weight (65). Set the Top Weight onto the rear stack of Weights (25). Insert both Short Weight Guides (73) into the stack of Weights. **Be sure that the holes in the Weight Guides are at the top, as shown.**

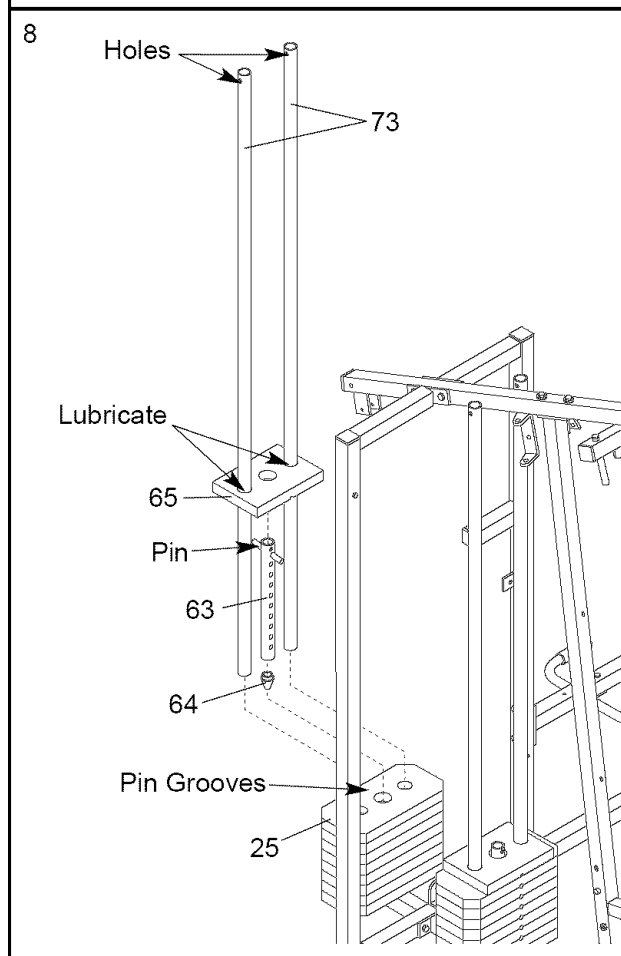

- Attach the upper ends of the Short Weight Guides (73) to the Top Frame (55) with a 5/16" x 6" Bolt (60), two 1/2" x 3/4" Spacers (61), and a 5/16" Nylon Locknut (3).

Attach the upper ends of the Long Weight Guides (62) to the Top Frame (55) with a 5/16" x 6" Bolt (60), two 1/2" x 3/4" Spacers (61), and a 5/16" Nylon Locknut (3).

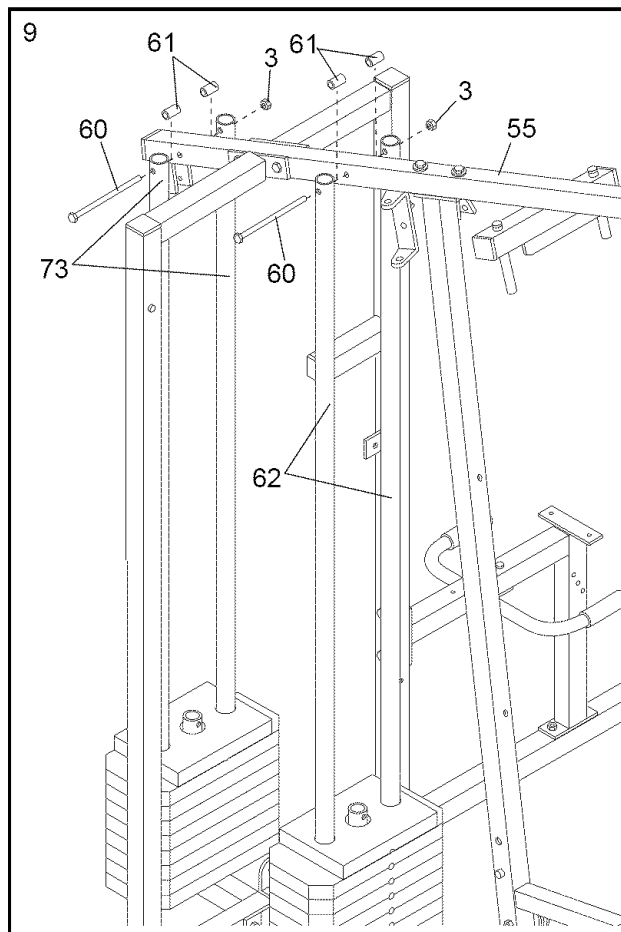

ARM ASSEMBLY

- Locate and open the parts bag labeled "ARM ASSEMBLY."

Be sure there is a Bushing (98) in each side of the Stabilizer (5). Press a 2" Square Inner Cap (27) into each end of the Leg Press Arm (96).

Lubricate a 3/8" x 3 1/4" Bolt (67). Attach the Leg Press Arm (96) to the Stabilizer (5) with the Bolt and a 3/8" Nylon Locknut (21). **Do not over tighten the Nylon Locknut; the Leg Press Arm must be able to pivot freely.**

Align the welded tubes on the Leg Press Plate (95) with one set of holes in the Leg Press Arm (96). Attach the Leg Press Plate to the Leg Press Arm with the Press Pin (97).

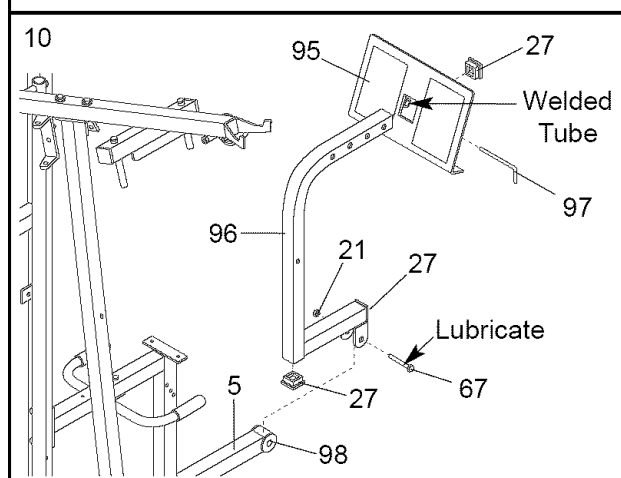

- Press a 1" x 7/8" Plastic Bushing (90) onto each welded spacer on the Press Frame (17). Slide the Press Frame into place onto the Base (4). **Note: This will be a tight fit. The Plastic Bushings should fit on each end of the indicated tube in the Base. Make sure that the indicated holes are on the side shown.**

Lubricate the 3/8" x 8" Bolt (59). Attach the Press Frame (17) to the Base (4) with the Bolt and a 3/8" Nylon Locknut (21).

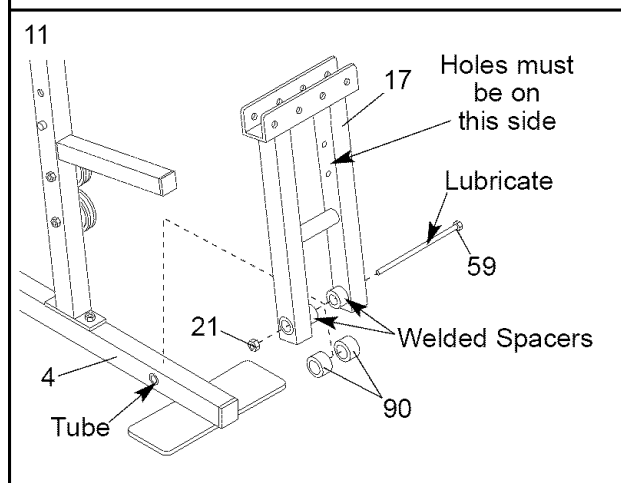

12. Press a 1" Round Inner Cap (49) into one of the Press Arms (46). Press a 1 3/4" Square Inner Cap (44) into the Press Arm.

Attach the Press Arm (46) to one side of the Press Frame (17) with two 5/16" x 2 1/2" Bolts (22) and two 5/16" Nylon Locknuts (3).

Assemble the other Press Arm (46) in the same manner.

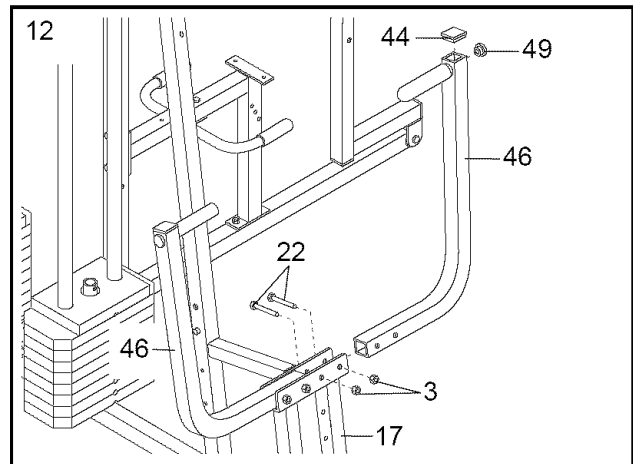

13. Identify the Right Arm (48) and the Left Arm (47). Note the position of the welded bracket on each Arm. **Arm identification is very important for step 14.**

Attach a "V"-Pulley (50) and a Long Cable Trap (31) to the Right Arm (48) with a 3/8" x 2 1/2" Bolt (86) and a 3/8" Nylon Locknut (21). **Do not tighten the Nylon Locknut yet.**

Attach a "V"-Pulley (50) and a Long Cable Trap (31) to the Left Arm (47) in the same manner.

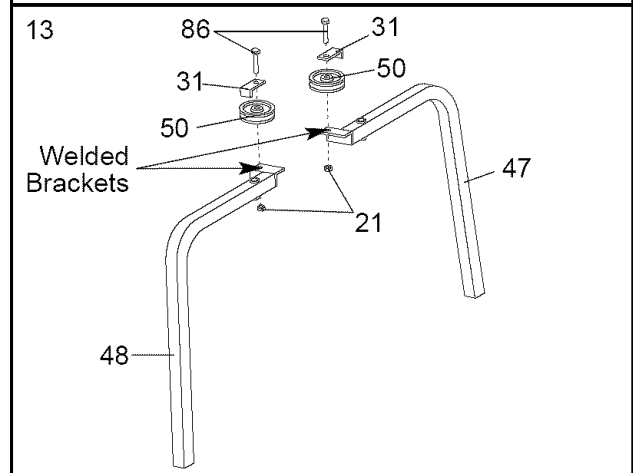

14. Lubricate both axles on the Top Frame (55).

Slide the Right Arm (48) onto the right axle on the Top Frame (55). **Note: Be careful not to confuse the Right Arm with the Left Arm (47); refer to step 13 to identify the Right Arm. Be sure that the upper end of the Right Arm is behind the indicated bracket on the Top Frame.**

See the inset drawing. Tap two 1" Retainers (69) and a 1" Round Cover Cap (70) onto the axle. **Be sure that the teeth on the Retainers bend toward the Round Cover Cap, as shown.**

Attach the Left Arm (47) in the same manner.

Press 1 3/4" Square Inner Caps (44) into the lower ends of the Right and Left Arms (47, 48). Wet the lower end of each Arm with soapy water. Slide a 10" Pad (45) onto the lower end of each Arm.

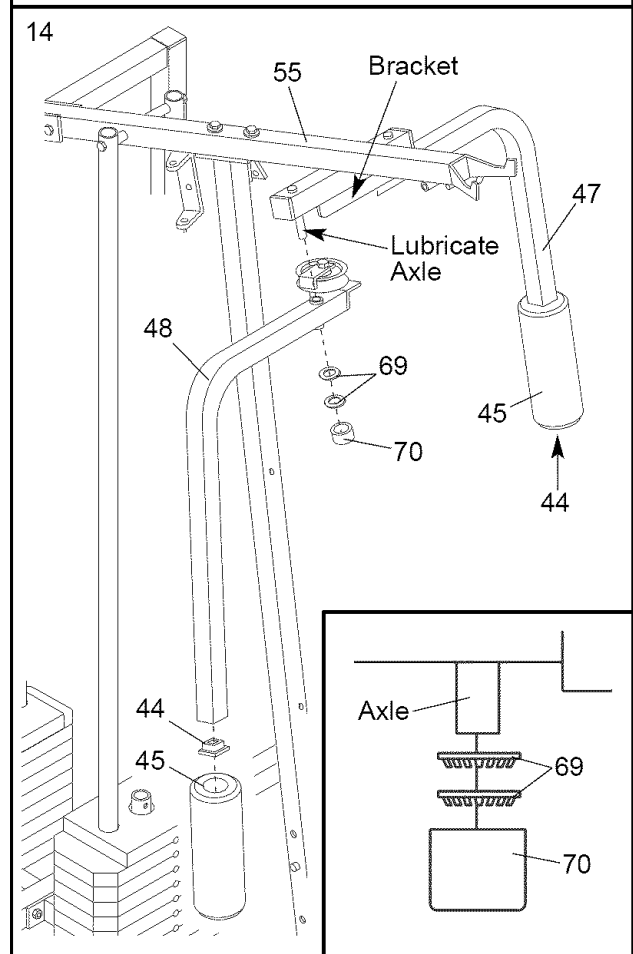

15. See the inset drawing. Attach the Military Press Arm (84) to the Pivot Arm (80) with two 5/16" x 2 1/4" Bolts (33) and two 5/16" Nylon Locknuts (3).

Press two 1 1/2" Square Inner Caps (32) into the indicated end of the Military Press Arm (84). Press two 1" Round Inner Caps (49) into the Military Press Arm.

Attach the Pivot Arm (80) to the Rear Upright (74) with a 3/8" x 3 1/4" Bolt (67) and a 3/8" Nylon Locknut (21).

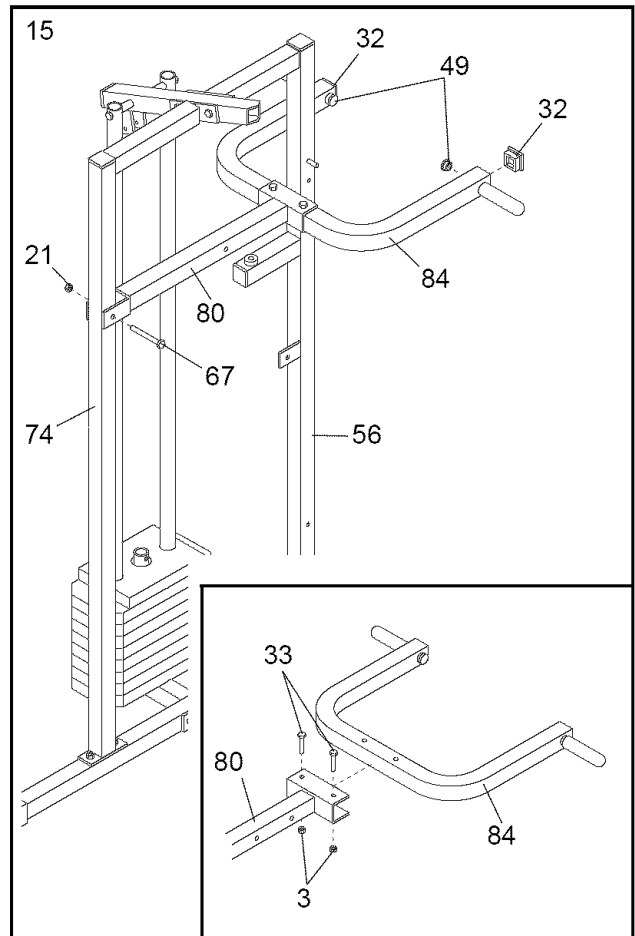

CABLE ASSEMBLY

16. Locate and open the parts bags labeled "CABLE ASSEMBLY" and "PULLEYS."

During steps 16 through 36, refer to the CABLE DIAGRAMS on pages 25–26 of this manual to verify proper cable routing. Before beginning this section, fully unwind the four Cables. Identify the four Cables by comparing the lengths and ends of the Cables. The approximate length of each Cable is listed (in inches) after the key number in the drawing.

IMPORTANT: While assembling the cables, do not over tighten the bolts and nuts attaching the pulleys; the pulleys must be able to turn freely.

17. Locate the High Cable (58). Wrap the High Cable around a 3 1/2" Pulley (15). Attach the Pulley to the Top Frame (55) with a 3/8" x 3 3/4" Bolt (88) and a 3/8" Nylon Locknut (21). Be sure that the end of the Cable with the ball is on the indicated side of the Pulley and that the Cable is between the Pulley and the hook.

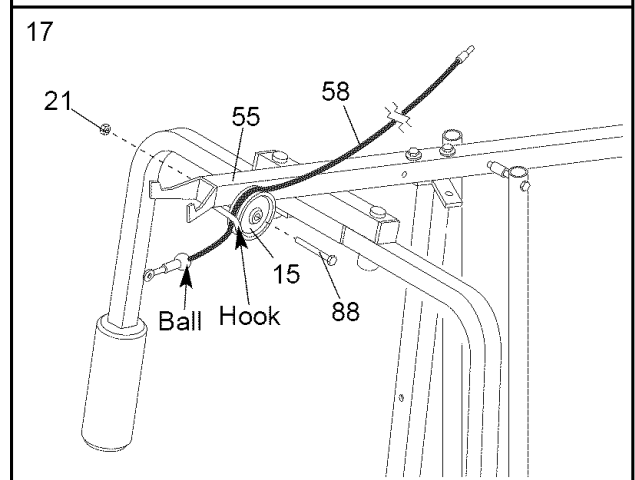
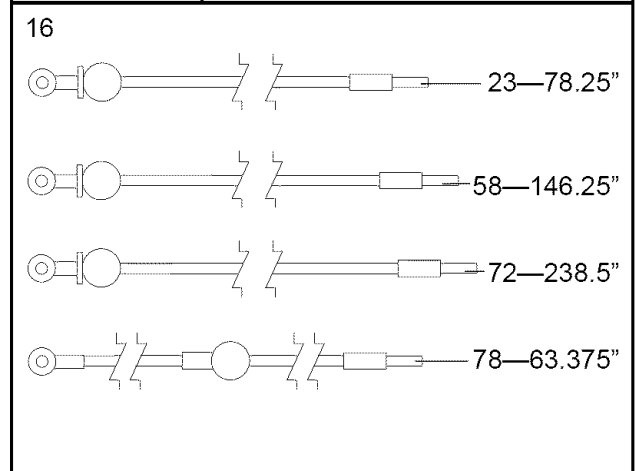

18. Wrap the High Cable (58) around a "V"-Pulley (50). Attach the "V"-Pulley and a Long Cable Trap (31) to the indicated bracket on the Front Upright (42) with a 3/8" x 2 1/2" Bolt (86) and a 3/8" Nylon Locknut (21). **Be sure that the Long Cable Trap is positioned to hold the Cable in place.**

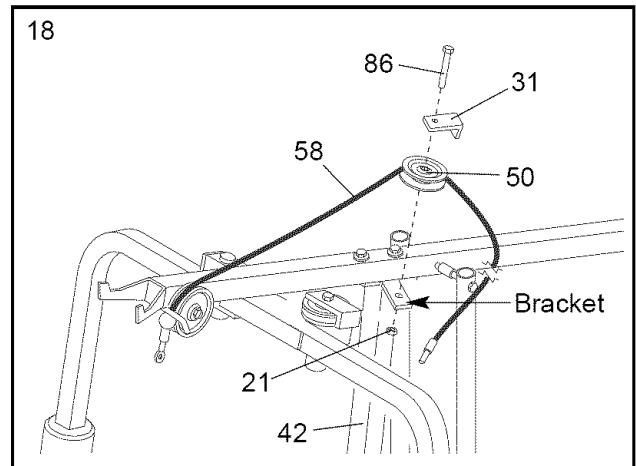

19. Route the High Cable (58) around the "V"-Pulley (50) on the Left Arm (47). **Be sure that the Cable is in the groove of the Pulley and that the Long Cable Trap (31) is positioned to hold the Cable in place.** Tighten the 3/8" x 2 1/2" Bolt (86) and the 3/8" Nylon Locknut (not shown).

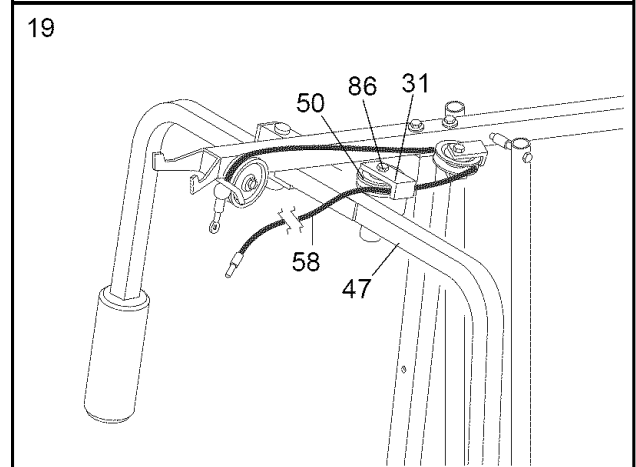

20. Route the High Cable (58) around the "V"-Pulley (50) on the Right Arm (48). **Be sure that the Cable is in the groove of the Pulley and that the Long Cable Trap (31) is turned to hold the Cable in place.** Tighten the 3/8" x 2 1/2" Bolt (86) and the 3/8" Nylon Locknut (not shown).

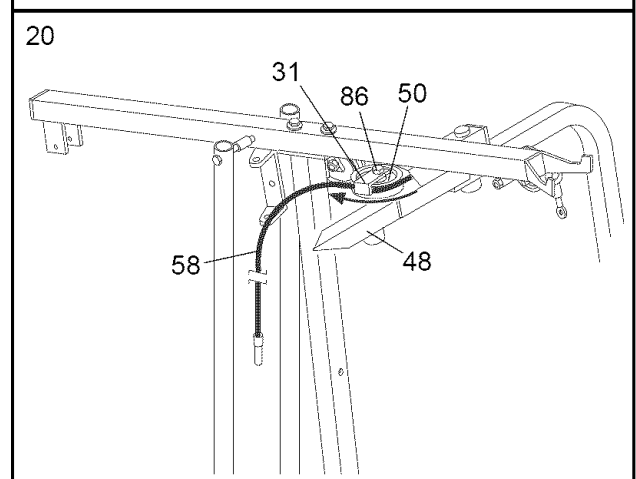

21. Attach the Pulley Bracket (20) to the Top Frame (55) with the 5/16" x 5" Bolt (68) and a 5/16" Nylon Locknut (3). **Do not over tighten the Nylon Locknut; the Pulley Bracket must be able to move freely.**

See the inset drawing. Route the High Cable (58) around the 3 1/2" Pulley (15) attached to the Pulley Bracket (20). Tighten the 3/8" x 2" Bolt (12) and the 3/8" Nylon Locknut (not shown). **Be sure that the Cable is in the groove of the Pulley and that the Cable Trap (66) is turned to hold the Cable in place.**

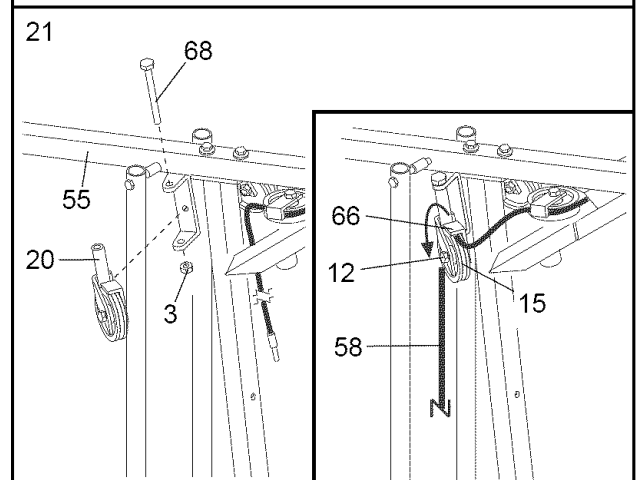

22. See the inset drawing. Attach a 3 1/2" Pulley (15) and a Cable Trap (66) to the upper hole in a Long "U"-Bracket (57) with a 3/8" x 2" Bolt (12) and a 3/8" Nylon Locknut (21). **Be sure that the Cable Trap is inside the Long "U"-Bracket. Note: This may come pre-assembled.**

Route the High Cable (58) through the Long "U"-Bracket (57) and the 3 1/2" Pulley (15) shown in the inset drawing. **Be sure that the Cable is in the groove of the Pulley and that the Cable and Pulley move smoothly.**

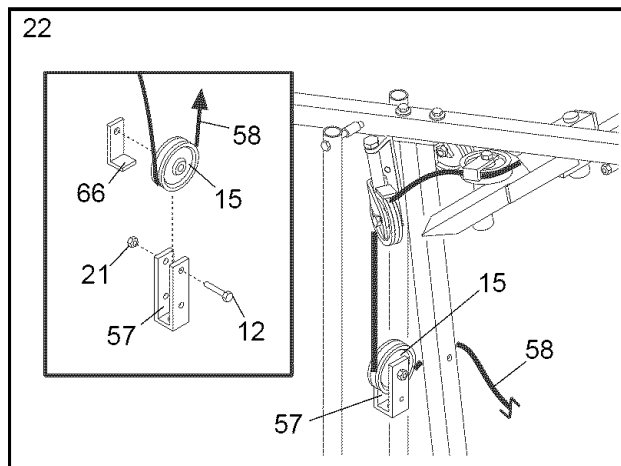

23. Wrap the High Cable (58) around a 3 1/2" Pulley (15). Attach the Pulley to the bracket on the Top Frame (55) with a 3/8" x 2" Bolt (12) and a 3/8" Nylon Locknut (21). **Be sure that the Cable is in the groove of the Pulley and that the Cable and Pulley move smoothly.**

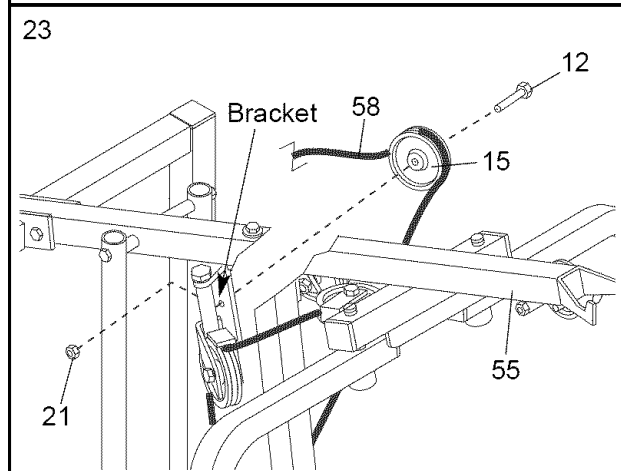

24. Attach the High Cable (58) to a Small "U"-Bracket (71) with a 1/4" Nylon Locknut (2) and a 1/4" Washer (10). **Do not completely tighten the Nylon Locknut. It should be threaded onto the end of the Cable only a couple of turns, as shown in the inset drawing.**

Attach the Small "U"-Bracket (71) to the indicated Weight Tube (63) with a 5/16" x 1 3/4" Bolt (24) and a 5/16" Nylon Locknut (3).

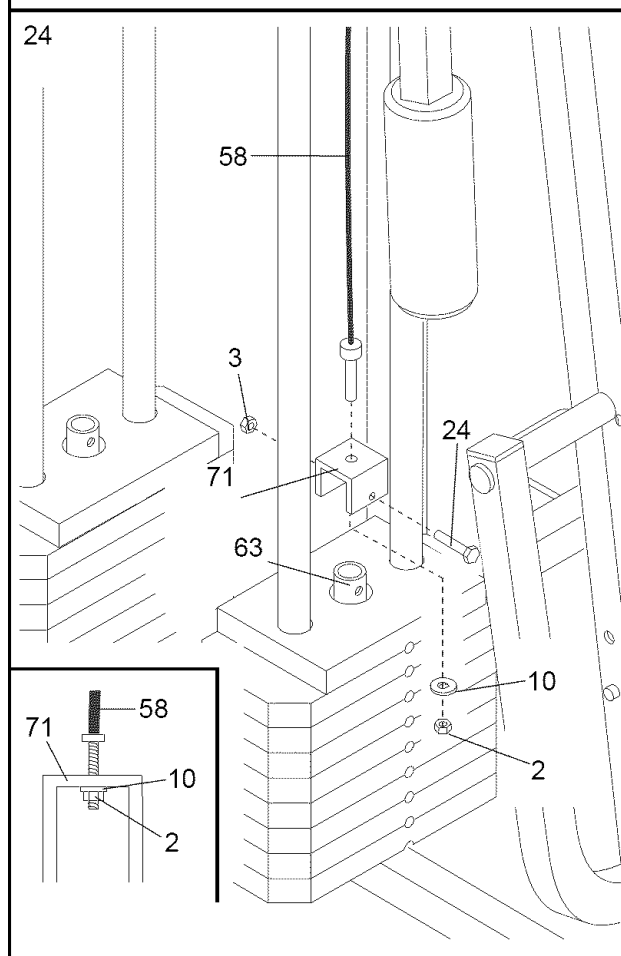

25. **Locate the Low Cable (23) and the bag labeled "LOW PULLEY."** Route the Low Cable under the 3 1/2" Low Pulley (76). Attach the Pulley and the 5/8" x 9/16" Spacer (7) to the Press Frame (17) with a 3/8" x 3 3/4" Bolt (88), 3/8" Washer (9), and a 3/8" Nylon Locknut (21). **Be sure that the parts are oriented as shown in the drawing, and that the end of the Cable with the ball is on the indicated side of the Press Frame, between the Pulley and the crossbar.**

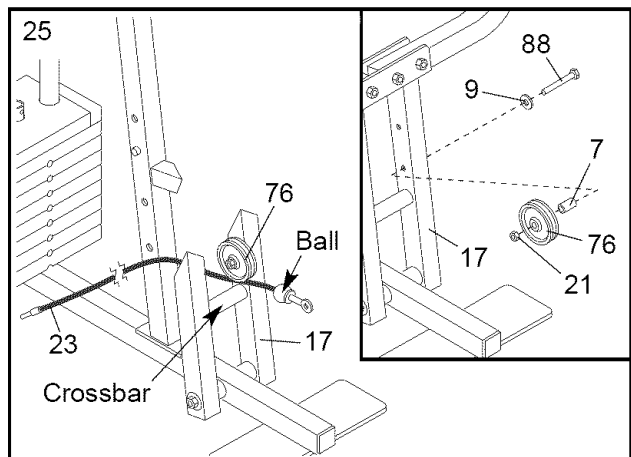

26. Route the Low Cable (23) around a 3 1/2" Pulley (15). Attach Pulley and a Cable Trap (66) to the lower hole in the Front Upright (42) with a 3/8" x 3 3/4" Bolt (88), a 3/8" Washer (9), and a 3/8" Nylon Locknut (21). **See the inset drawing. Be sure that the Cable Trap is turned to hold the Cable in place and that the Cable is routed around the Pulley as shown.**

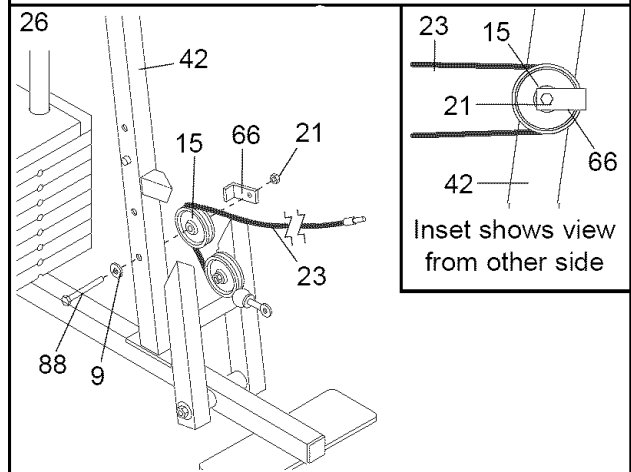

27. Route the Low Cable (23) around a 3 1/2" Pulley (15). Attach the Pulley and a Cable Trap (66) to the upper hole in the Press Frame (17) with a 3/8" x 3 1/2" Bolt (16), a 3/8" Washer (9), and a 3/8" Nylon Locknut (21). **Be sure that the Cable Trap is turned to hold the Cable in place and that the Cable is routed around the Pulley as shown.**

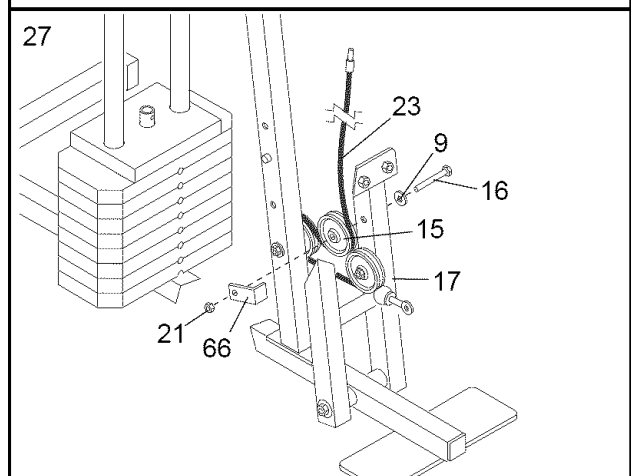

28. Route the Low Cable (23) around another 3 1/2" Pulley (15). Attach the Pulley and a Cable Trap (66) to the upper hole in the Front Upright (42) with a 3/8" x 3 3/4" Bolt (88), a 3/8" Washer (9), and a 3/8" Nylon Locknut (21). **See the inset drawing. Be sure that the Cable Trap is turned to hold the Cable in place and that the Cable is routed around the Pulley as shown.**

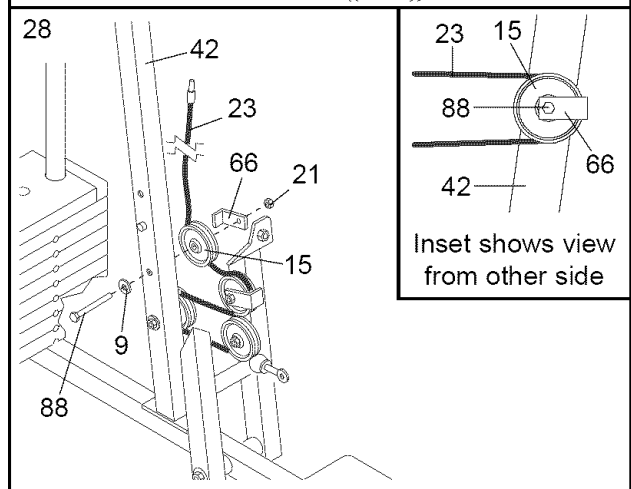

29. Attach the end of the Low Cable (23) to the Long "U"-Bracket (57) with a 1/4" Nylon Locknut (2) and a 1/4" Washer (10). **Do not completely tighten the Nylon Locknut. It should be threaded onto the end of the Cable so only a couple of threads are showing above the Nylon Locknut, as shown in the inset drawing.**

You may need to lift the Top Weight (not shown) on the High Cable (58) to get enough slack to attach the Low Cable (23) to the Long "U"-Bracket (57).

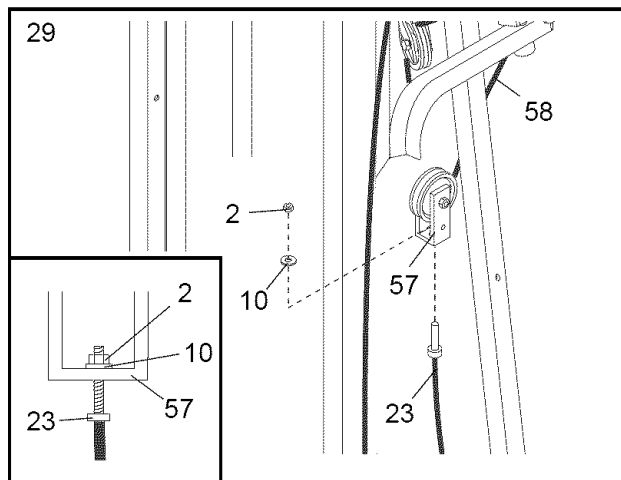

30. **Locate the Military Press Cable (72).** Attach the Military Press Cable to the other Small "U"-Bracket (71) with a 1/4" Nylon Locknut (2) and a 1/4" Washer (10). **Do not completely tighten the Nylon Locknut; it should be threaded onto the end of the Cable only a couple of turns, as shown in the inset drawing.**

Attach the Small "U"-Bracket (71) to the indicated Weight Tube (63) with a 5/16" x 1 3/4" Bolt (24) and a 5/16" Nylon Locknut (3).

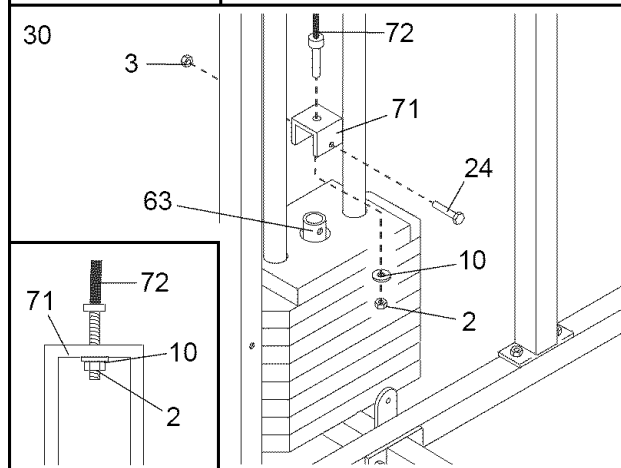

31. Wrap the Military Press Cable (72) around a 3 1/2" Pulley (15). Attach the Pulley to the Top Frame (55) with a 3/8" x 2" Bolt (12) and a 3/8" Nylon Locknut (21).

See the inset drawing. Wrap the Military Press Cable (72) around a 3 1/2" Pulley (15). Attach the Pulley and a Cable Trap (66) to the bracket on the Stabilizer (5) with a 3/8" x 2" Bolt (12) and a 3/8" Nylon Locknut (21). **Be sure that the Cable Trap is turned to hold the Cable in place.**

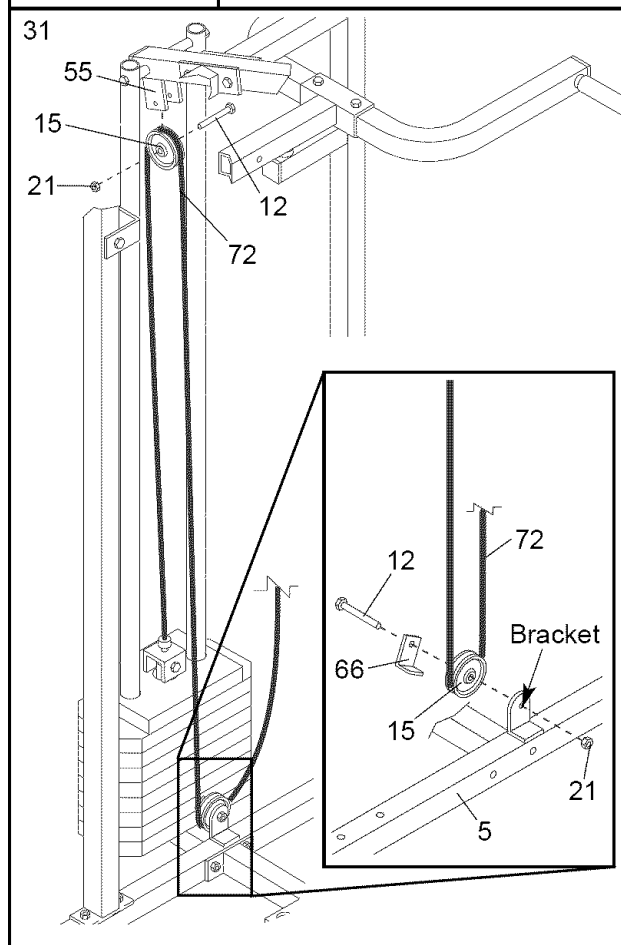

32. Wrap the Military Press Cable (72) around a 3 1/2" Pulley (15). Attach the Pulley and a Cable Trap (66) to the Pivot Arm (80) with the 3/8" x 5" Bolt (101). **Be sure the Bolt is on the side shown, and that the Cable Trap is positioned to hold the Cable in place. Do not attach a locknut yet.**

See the inset drawing. Wrap the Military Press Cable (72) around a 3 1/2" Pulley (15). Attach the Pulley and a Cable Trap (66) to the upper hole in the Long "U"-Bracket (57) with a 3/8" x 2" Bolt (12) and a 3/8" Nylon Locknut (21). **Be sure that the Cable Trap is inside the Long "U"-Bracket, that the Cable is in the groove of the Pulley, and that the Cable and Pulley move smoothly.**

Wrap the Military Press Cable (72) around another 3 1/2" Pulley (15). Attach the Pulley and a Cable Trap (66) to the 3/8" x 5" Bolt (101) on the other side of the Pivot Arm (80) with a 3/8" Nylon Locknut (21). **Be sure that the Cable Trap is positioned to hold the Cable in place, and that the Cable is routed as shown.**

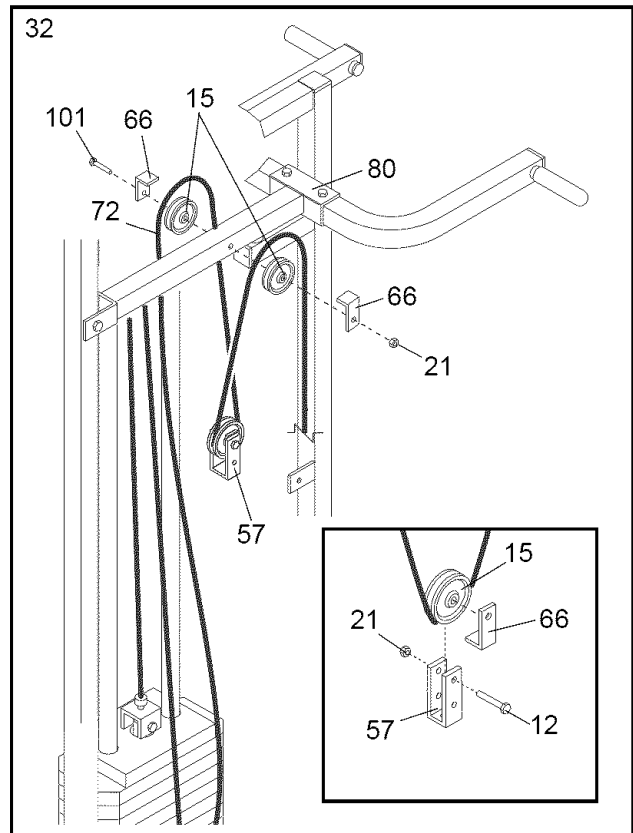

33. Wrap the Military Press Cable (72) around a 3 1/2" Pulley (15). Attach the Pulley and a Cable Trap (66) to the Leg Press Upright (56) with a 3/8" x 2" Bolt (12) and a 3/8" Nylon Locknut (21). **Be sure the Cable Trap is positioned to hold the Cable in place.**

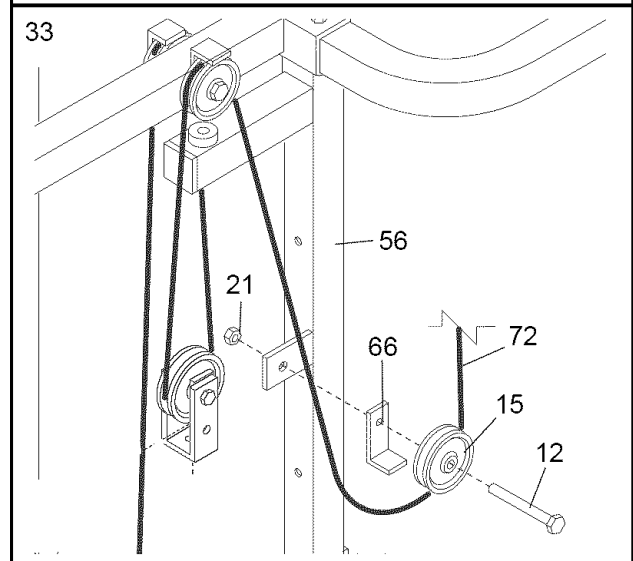

34. Lay the Military Press Cable (72) over a 3 1/2" Pulley (15). Attach the Pulley and both Pulley Covers (77) to the Leg Press Upright (56) with a 3/8" x 3 3/4" Bolt (88), two 3/8" Washers (9), and a 3/8" Nylon Jamnut (99).

Make sure that the Military Press Cable (72) is between the 3 1/2" Pulley (15) and the post. Be sure that the Cable and Pulley move smoothly.

The Pulley Covers (77) must be turned so that the large tabs face toward the weight system. See the inset drawing.

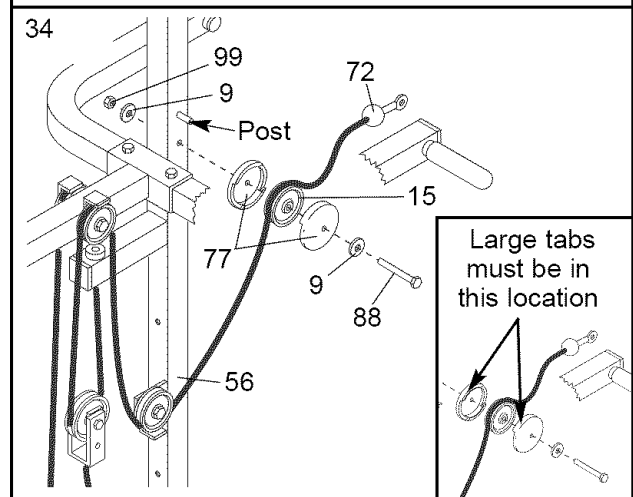

35. **Locate the Leg Press Cable (78).** Attach the end of the Leg Press Cable to the Long "U"-Bracket (57) with a 1/4" Nylon Locknut (2) and a 1/4" Washer (10). **Do not completely tighten the Nylon Locknut. It should be threaded onto the end of the Cable only a couple of turns, as shown in the inset drawing.**

Wrap the Leg Press Cable (78) around a 3 1/2" Pulley (15). Attach the Pulley to the Leg Press Upright (56) with the 3/8" x 3 3/4" Bolt (88), a 3/8" Washer (9), and a 3/8" Nylon Locknut (21). **Be sure that the Cable and Pulley move smoothly and that the Cable is between the Pulley and the welded rod. The ball on the Cable must be on the indicated side of the Pulley.**

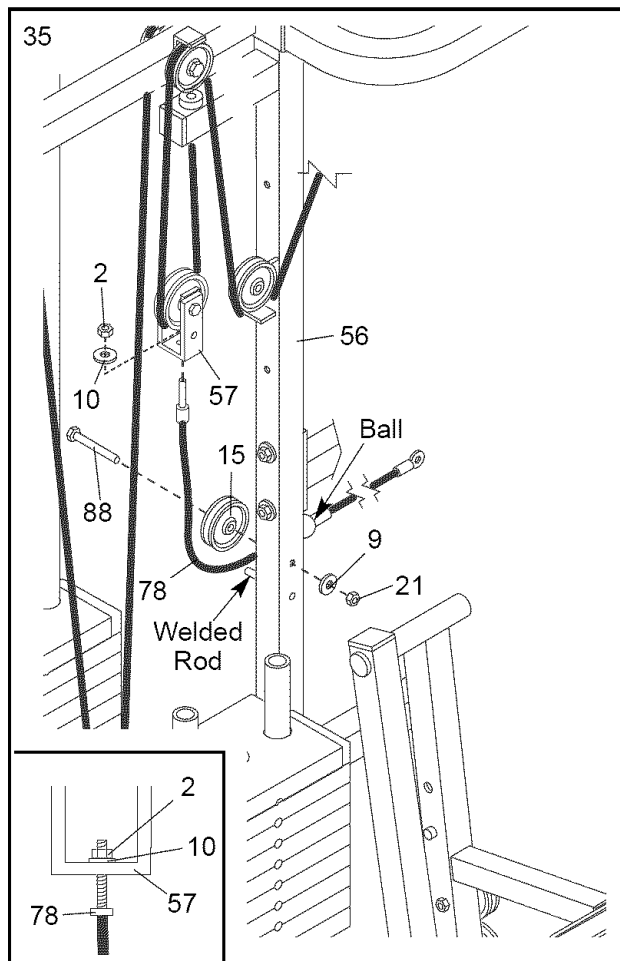

36. Attach the Press Bracket (94) to the Leg Press Arm (96) with a 3/8" x 3" Bolt (100) and a 3/8" Nylon Jamnut (99).

Wrap the Leg Press Cable (78) around a 3 1/2" Pulley (15). Attach the Pulley to the Press Bracket (94) with a 3/8" x 2" Bolt (12) and a 3/8" Nylon Locknut (21).

Slide a 5/16" Washer (8) onto a 5/16" x 2 3/4" Bolt (11). Insert the Bolt through the center hole in the Leg Press Seat Frame (79) from the indicated side. (Note: The three holes are for cable adjustment.) Tighten a 5/16" Washer (8) and a 5/16" Nylon Jamnut (93) onto the Bolt. Slide the end of the Leg Press Cable (78) onto the end of the Bolt. Thread another 5/16" Nylon Jamnut onto the Bolt. **Do not fully tighten the second Jamnut; there must be room between the two Jamnuts for the end of the Cable to pivot.**

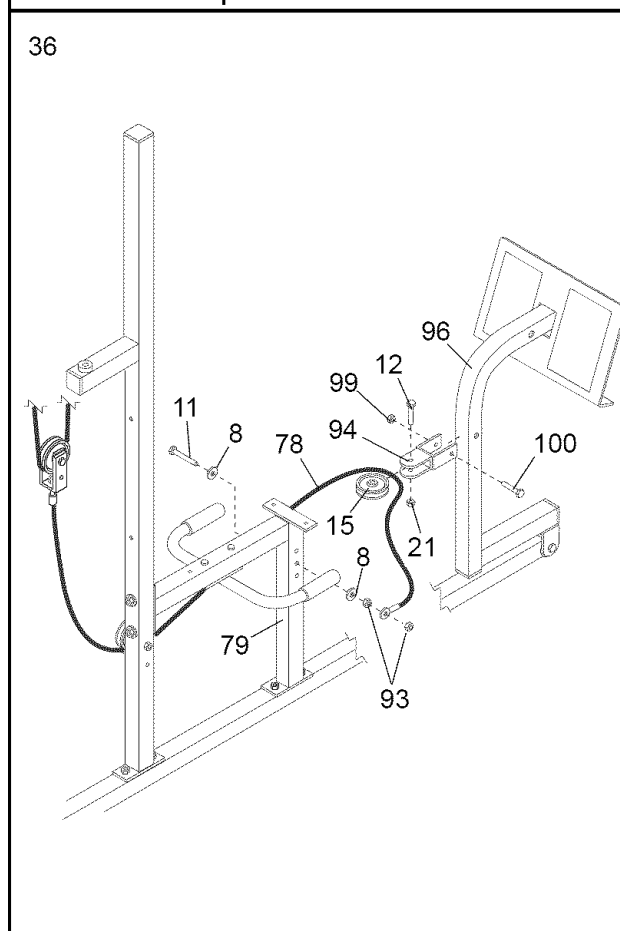

SEAT ASSEMBLY

37. Locate and open the parts bag labeled "SEAT ASSEMBLY."

Insert a 1/4" x 2 1/2" Carriage Bolt (92) through the center hole in a Seat Plate (37). Attach the Seat Plate to the Leg Press Backrest (85) with two 1/4" x 3/4" Screws (18).

Insert the 1/4" x 2 1/2" Carriage Bolt (92) through the indicated hole in the Leg Press Upright (56). Tighten a 1/4" Nylon Locknut (2) with a 1/4" Washer (10) onto the Carriage Bolt. Attach the top of the Leg Press Backrest (85) to the Leg Press Upright with a 1/4" x 2 1/2" Screw (43) and a 1/4" Washer (10).

38. Attach one end of a Seat (13) to the Leg Press Seat Frame (79) with two 1/4" x 3/4" Screws (18). Attach the other end of the Seat to the Leg Press Seat Frame with a 1/4" Washer (10) and a 1/4" x 2 1/2" Screw (43).

39. Attach the Front Backrest (41) to the Front Upright (42) with two 1/4" x 2 1/2" Screws (43) and two 1/4" Washers (10). **Note: Make sure the Backrest is oriented as shown.**

40. Press a 1 1/2" Square Inner Cap (32) into the Front Seat Frame (36).

Insert a 1/4" x 2" Carriage Bolt (38) through the center hole in the Seat Plate (37). Attach the Seat Plate to the Seat (13) with two 1/4" x 3/4" Screws (18).

Insert the 1/4" x 2" Carriage Bolt (38) through the indicated hole in the Front Seat Frame (36). Tighten a 1/4" Nylon Locknut (2) with a 1/4" Washer (10) onto the Carriage Bolt.

Attach the other end of the Seat (13) to the Front Seat Frame (36) with a 1/4" Washer (10) and a 1/4" x 2" Machine Screw (81).

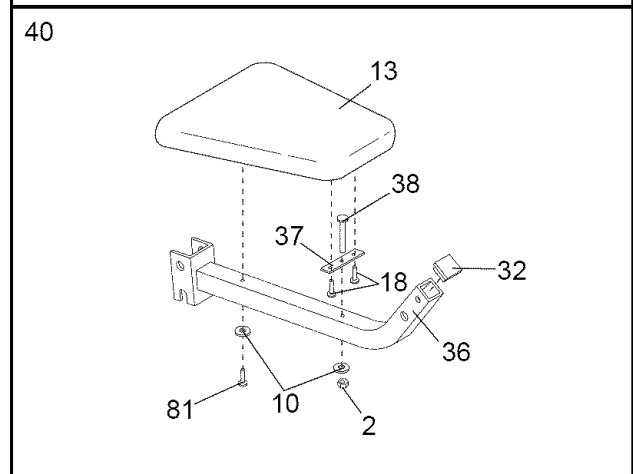
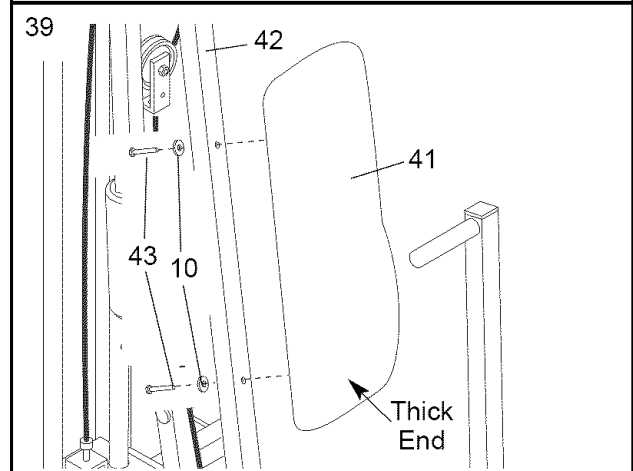
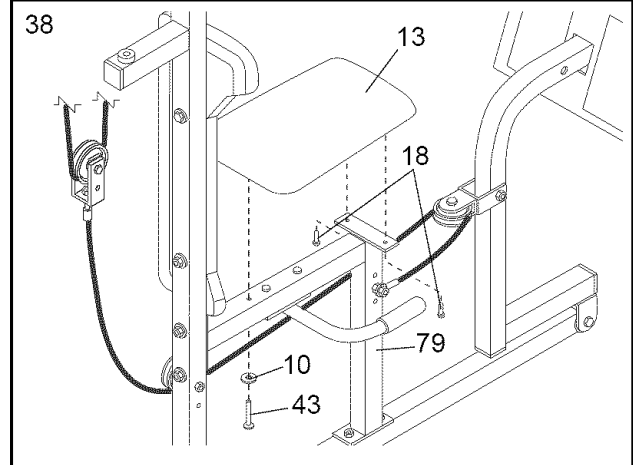
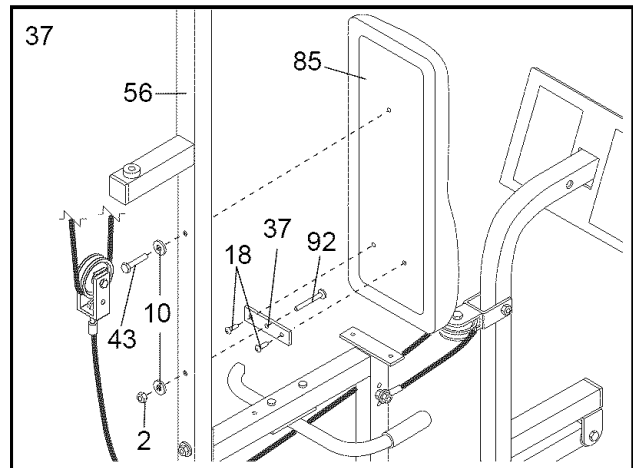

41. Press a 1 1/2" Square Inner Cap (32) into the Leg Lever (29).

Lubricate the 5/16" x 2 1/4" Bolt (33). Attach the Leg Lever (29) to the Front Seat Frame (36) with the Bolt and a 5/16" Nylon Locknut (3).

Insert the 3/8" x 2" Eyebolt (35) into the Leg Lever (29) from the direction shown. Tighten a 3/8" Washer (9) and a 3/8" Nylon Locknut (21) onto the Eyebolt.

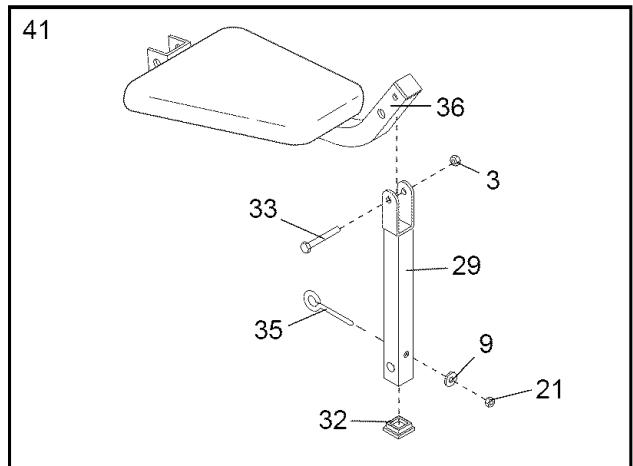

42. Rest the Front Seat Frame (36) on the indicated pin in the Front Upright (42). Attach the Front Seat Frame to the Front Upright with a 5/16" x 2 3/4" Carriage Bolt (14), 5/16" Washer (8), and the Seat Knob (40).

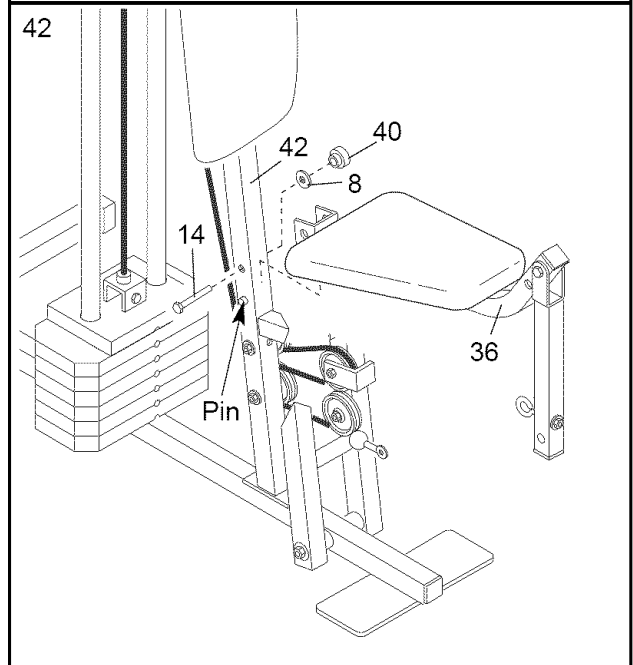

43. Press two 3/4" Round Inner Caps (34) into each Pad Tube (28).

Insert a Pad Tube (28) into the Front Seat Frame (36). Slide a Foam Pad (30) onto each end of the Pad Tube.

Insert the other Pad Tube (28) into the Leg Lever (29). Slide a Foam Pad (30) onto each end of the Pad Tube.

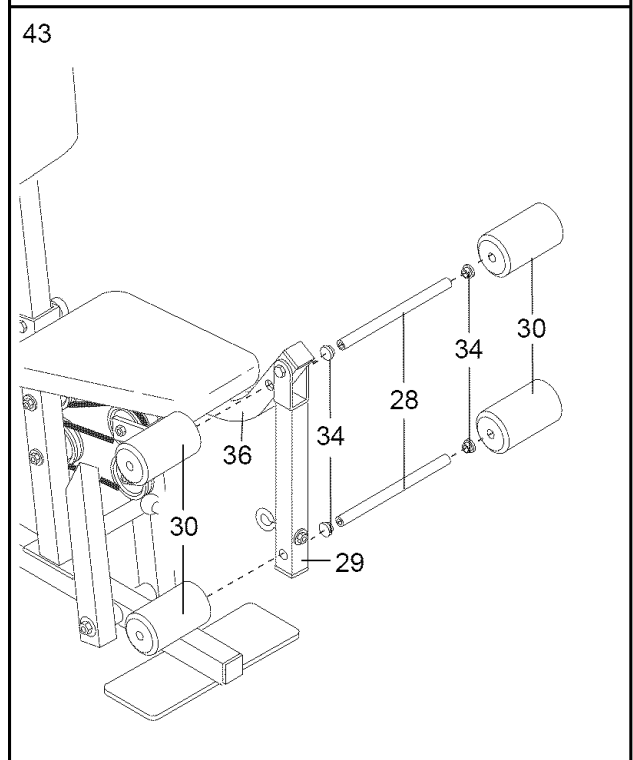

44. Remove the adhesive backing from the PRO 9400 decal and apply it to the Front Upright (42).

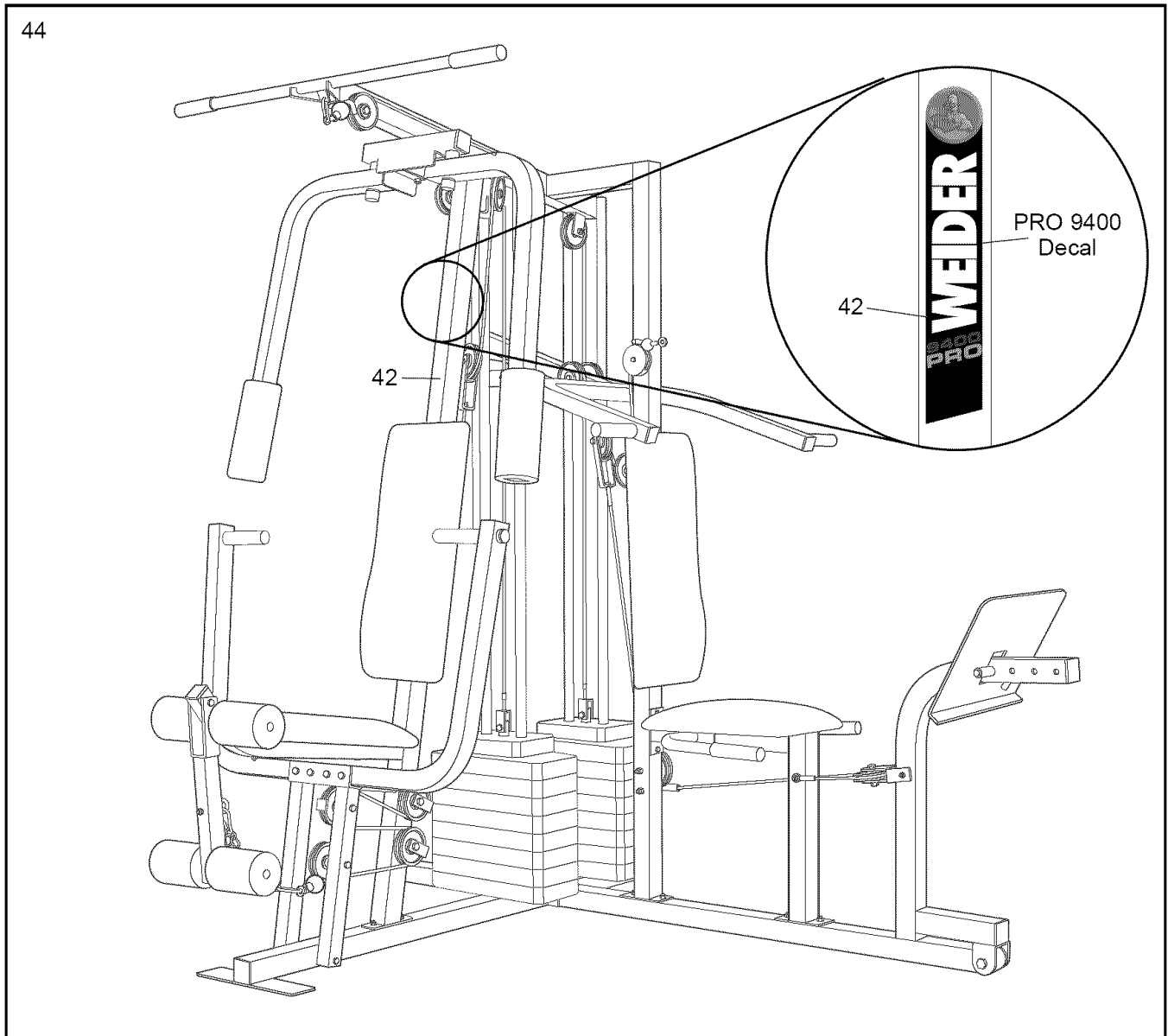

45. Make sure that all parts have been properly tightened. The use of the remaining parts will be explained in ADJUSTMENTS, beginning on page 21 of this manual.

Before using the weight system, pull each cable a few times to be sure that the cables move smoothly over the pulleys. If one of the cables does not move smoothly, find and correct the problem. **IMPORTANT: If the cables are not properly installed, they may be damaged when heavy weight is used. See the CABLE DIAGRAMS on page 25 and 26 of this manual for proper cable routing. If there is any slack in the cables, you will need to remove it by tightening the cables. See TROUBLE-SHOOTING AND MAINTENANCE on page 24.**

ADJUSTMENTS

The instructions below describe how each part of the weight system can be adjusted. Refer to the exercise guide accompanying this manual to see how the weight system should be set up for each exercise. **IMPORTANT: When attaching the lat bar or nylon strap, make sure that the attachments are in the correct starting position for the exercise to be performed. If there is any slack in the cables or chain as an exercise is performed, the effectiveness of the exercise will be reduced.**

CHANGING THE WEIGHT SETTING

The weight system features two weight stacks. The front weight stack is connected to the upper and lower pulleys, the press arm, and the butterfly arms. The rear weight stack is connected to the military press arm and leg press.

To change the weight setting of either weight stack, insert a Weight Pin (26) under the desired Weight (25). Insert the Weight Pin until the bent end of the Weight Pin is touching the Weights, and turn the bent end downward. The weight setting of either weight stack can be changed from 6.5 pounds to 106.5 pounds, in increments of 12.5 pounds. **Note: Due to the cables and pulleys, the amount of resistance at each exercise station may vary from the weight setting. Use the WEIGHT RESISTANCE CHART on page 23 to find the approximate amount of resistance at each weight station.**

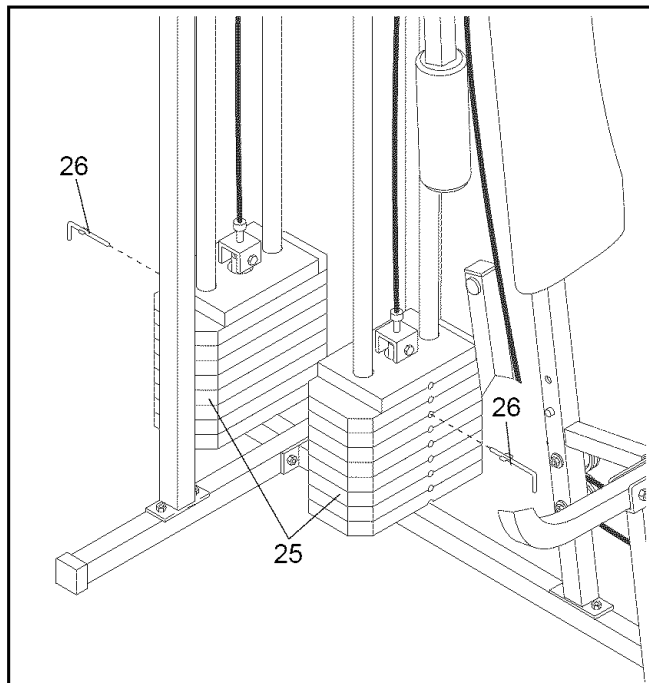

ATTACHING THE LAT BAR OR NYLON STRAP TO THE HIGH PULLEY STATION

Attach the Lat Bar (54) to the High Cable (58) with a Cable Clip (53). For some exercises, the Chain (52) should be attached between the Lat Bar and the High Cable with two Cable Clips. **Adjust the length of the Chain between the Lat Bar and the High Cable so the Lat Bar is in the correct starting position for the exercise to be performed.**

The Nylon Strap (39) can be attached in the same manner.

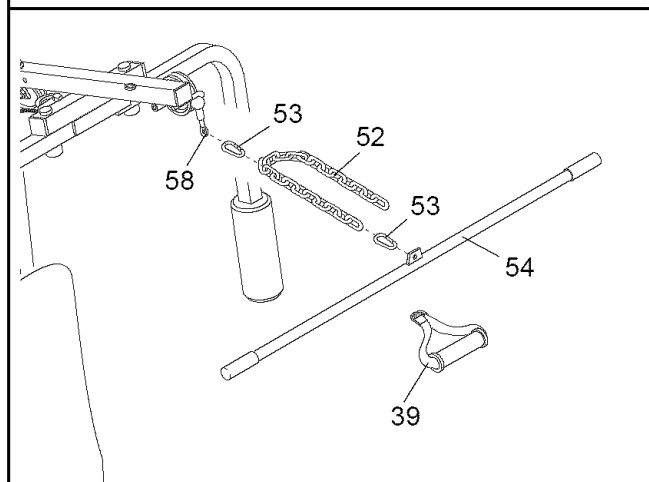

ATTACHING THE LAT BAR OR NYLON STRAP TO THE LOW PULLEY STATION

Attach the Lat Bar (54) to the Low Cable (23) with a Cable Clip (53). For some exercises, the Chain (52) should be attached between the Lat Bar and the Low Cable with two Cable Clips. **Adjust the length of the Chain between the Lat Bar and the Low Cable so the Lat Bar is in the correct starting position for the exercise to be performed.**

The Nylon Strap (39) can be attached in the same manner.

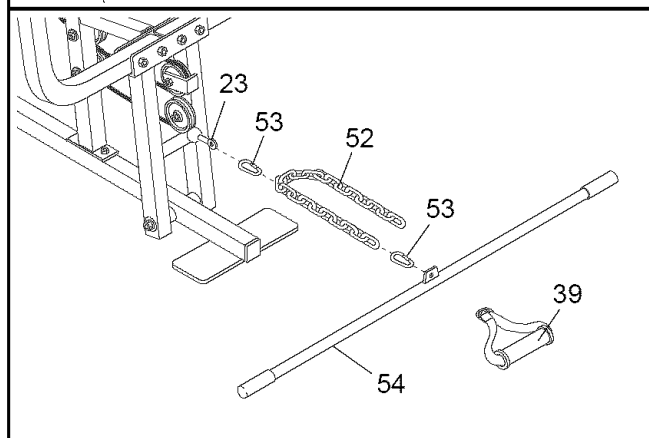

ATTACHING AND REMOVING THE SEAT

To attach the Seat (13), set the bracket on the Front Seat Frame (36) onto the indicated pin on the Front Upright (42). Attach the Front Seat Frame to the Front Upright with the 5/16" x 2 3/4" Carriage Bolt (14), 5/16" Washer (8) and the Seat Knob (40).

For some exercises, the Seat (13) must be removed. First, be sure that the chain is not attached to the leg lever. Next, remove the Seat Knob (40), 5/16" Washer (8) and the 5/16" x 2 3/4" Carriage Bolt (14) from the Front Seat Frame (36). Lift the Front Seat Frame off the Front Upright (42).

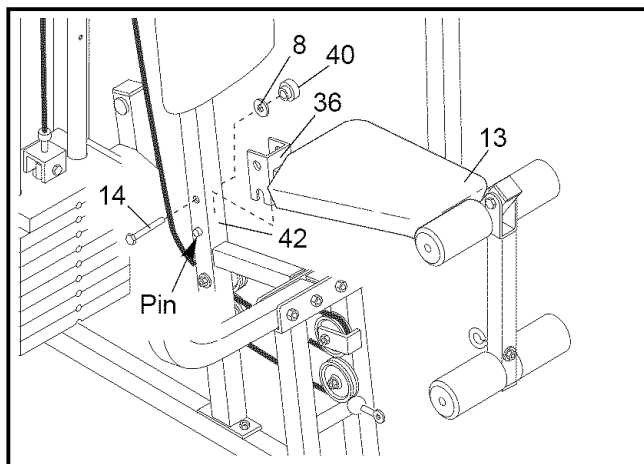

ATTACHING THE LEG LEVER TO THE LOW PULLEY STATION

To use the Leg Lever (29), the seat must be attached to the front upright (see ATTACHING AND REMOVING THE SEAT above).

Attach one end of the Chain (52) to the Low Cable (23) with a Cable Clip (53). Attach the other end of the Chain to the 5/16" x 2" Eyebolt (35) with a Cable Clip.

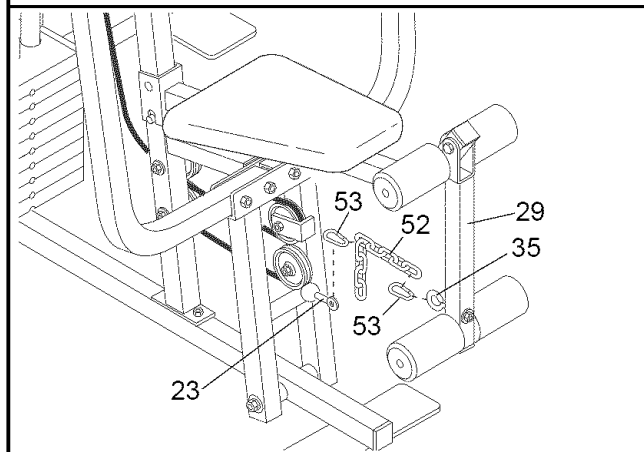

ADJUSTING THE LEG PRESS PLATE

Remove the Press Pin (97) from the Leg Press Plate (95) and the Leg Press Arm (96).

Align the welded tubes on the Leg Press Plate (95) with the desired set of holes in the Leg Press Arm (96). Re-insert the Press Pin (97) through the welded tubes on Leg Press Plate and the holes in the Leg Press Arm.

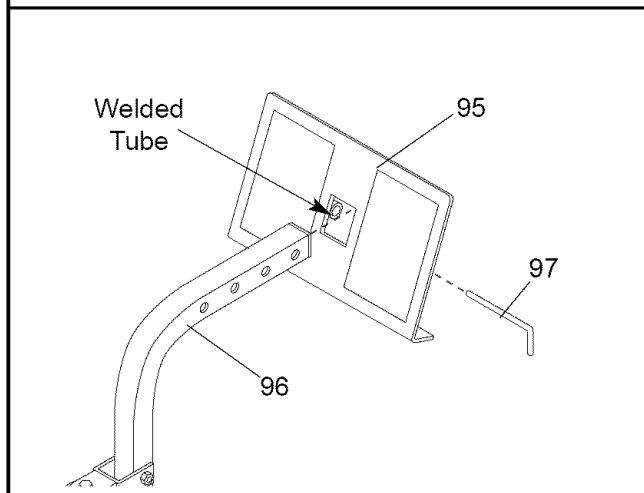

WEIGHT RESISTANCE CHART

This chart shows the approximate weight resistance at each weight station. "Top" refers to the 6.5 lb. top weight. The other numbers refer to the 12.5 lb. weight plates. The butterfly arm resistance listed is the resistance for each butterfly arm. **The actual resistance at each weight station may vary due to differences in individual weight plates, as well as friction between the cables, pulleys, and weight guides.**

WEIGHT PLATES	PRESS ARM (lbs.)	BUTTERFLY ARM (lbs.)	LEG LEVER (lbs.)	HIGH PULLEY (lbs.)	LOW PULLEY (lbs.)	MILITARY PRESS ARM (lbs.)	LEG PRESS (lbs.)	AB STATION (lbs.)
Top	20	10	15	16	30	46	40	30
1	45	22	36	30	60	72	80	45
2	70	33	54	52	100	97	146	59
3	99	42	75	68	130	122	166	74
4	128	48	96	87	170	147	210	88
5	153	60	115	100	200	172	240	103
6	184	69	137	120	255	198	268	117
7	204	79	146	135	270	223	325	132
8	247	91	176	155	320	248	360	147

TROUBLE-SHOOTING AND MAINTENANCE

TIGHTENING THE CABLES

Woven cable, the type of cable used on the weight system, can stretch slightly when it is first used. If there is slack in the cables before resistance is felt, the cables should be tightened. If any slack is felt when using the front weight stack, both the High Cable (58) and the Low Cable (23) will need to be tightened. If any slack is felt when using the rear weight stack, both the Military Press Cable (72) and the Leg Press Cable (78) will need to be tightened.

To tighten the cables, insert the weight pin into the middle of the weight stack. Slack can be removed from these cables several ways:

- See drawing 1. Tighten the 1/4" Nylon Locknut (2) that connects the end of the Low Cable (23) to the Long "U"-Bracket (57).

The Leg Press Cable (78) can be tightened in the same manner.

- See drawing 1. Remove the 3/8" Nylon Locknut (21) and the 3/8" x 2" Bolt (12) from the Cable Trap (66), 3 1/2" Pulley (15), and Long "U"-Bracket (57). Re-attach the Pulley and Cable Trap to the other hole in the Long "U"-Bracket. Be sure that the Cable Trap is in the proper position and that the Cable and Pulley move smoothly.

The other Long "U"-Bracket (57) can be adjusted in the same manner.

- See drawing 2. Tighten the 1/4" Nylon Locknut (2) that connects the end of the High Cable (58) to the Small "U"-Bracket (71).

The Military Press Cable (72) can be tightened in the same manner.

- See Drawing 3. If additional slack is felt while using the Leg Press Arm, then the end of the Leg Press Cable (78) must be moved to the next hole in the Leg Press Seat Frame (79). Remove the 5/16" x 2 3/4" Bolt (11), the two 5/16" Washers (8), the end of the Cable, and both 5/16" Nylon Jamnuts (93) from the Leg Press Seat Frame. Re-attach the Bolt, the Washers, the end of the Cable, and the Nylon Jamnuts to the next hole in the Leg Press Seat Frame.

Do not over tighten the cables. The top weight will be lifted off the weight stack.

If a cable tends to slip off the pulleys often, it may have become twisted. Remove the cable and re-install it.

If the cables need to be replaced, see ORDERING REPLACEMENT PARTS on the back cover of this manual.

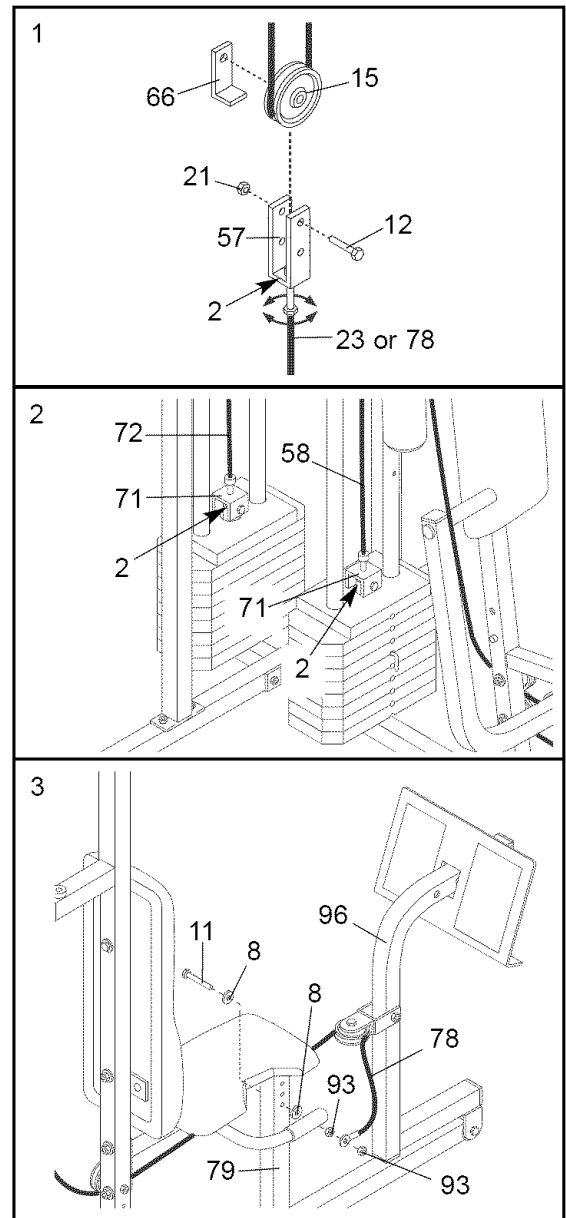

CABLE DIAGRAMS

The cable diagrams on these pages show the proper routing of the High Cable (58), the Low Cable (23), the Military Press Cable (72), and the Leg Press Cable (78). Use the diagrams to be sure that the four cables and the cable traps have been assembled correctly. If the cables have not been correctly routed, the weight system will not function properly and damage may occur. The insets show the proper positioning of the cable traps. The cable traps should be positioned so that the cables will not come off the pulleys. **Be sure that the cable traps do not touch or bind the cables.**

High Cable (58) and Low Cable (23)

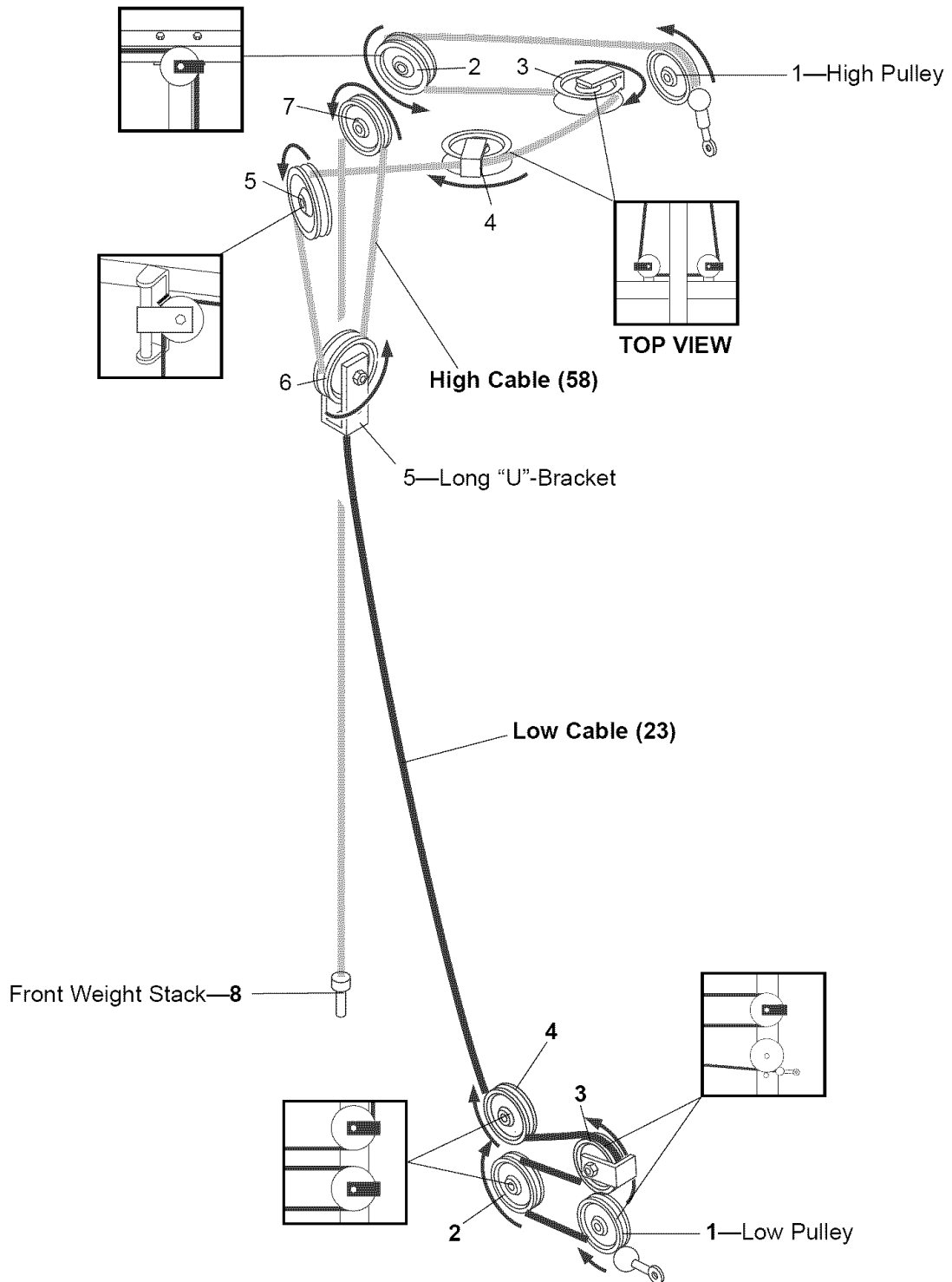

Military Press Cable (72) and Leg Press Cable (78)

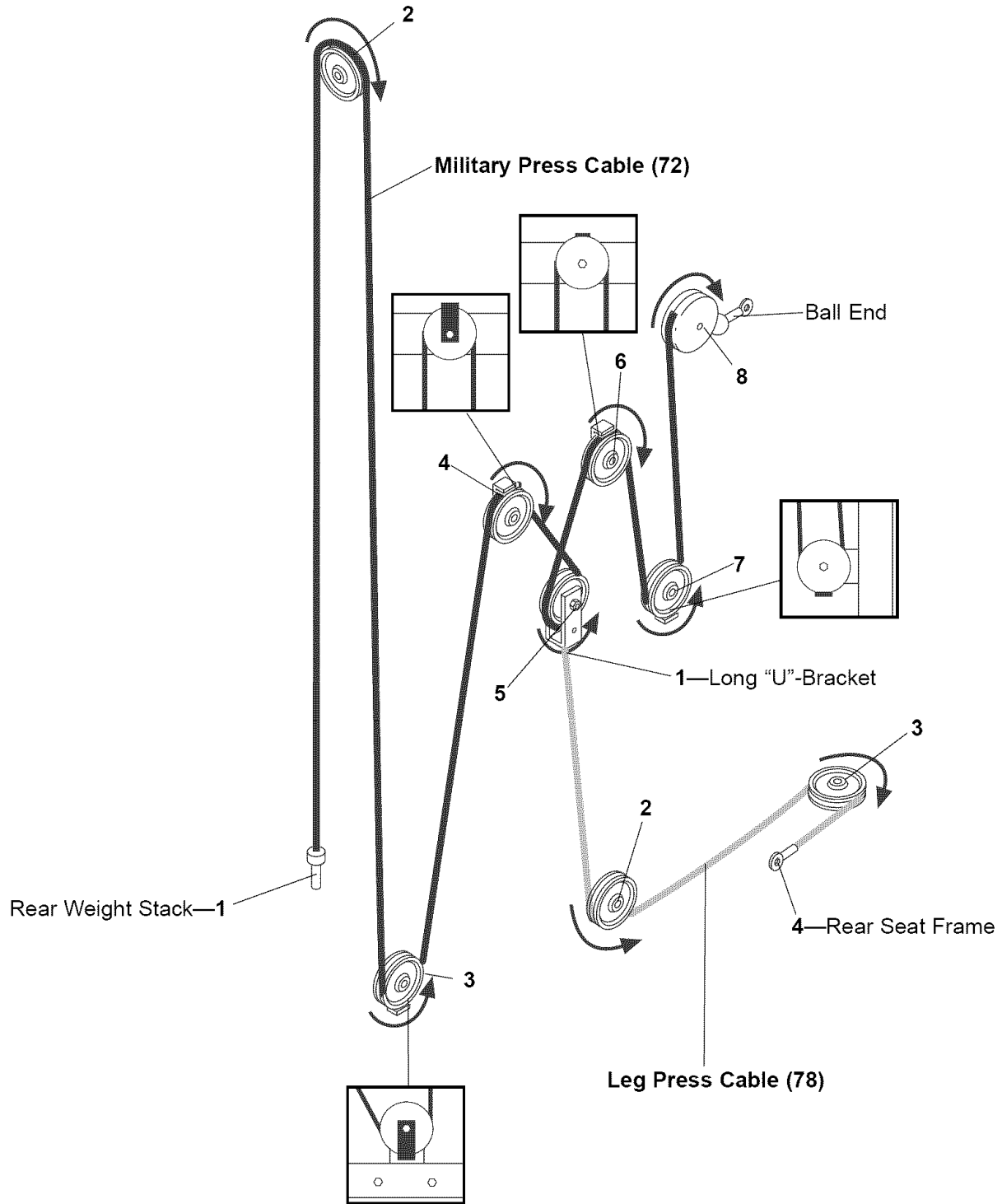

NOTES

EXPLODED DRAWING—Model No. WESY39311

R0402A

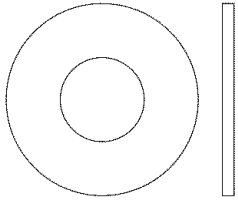

3/8" Washer (9)

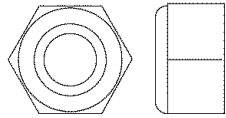

3/8" Nylon Locknut (21)

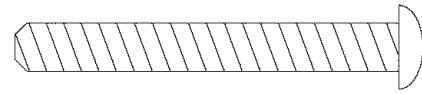

1/4" x 2" Machine Screw (81)

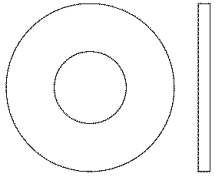

5/16" Washer (8)

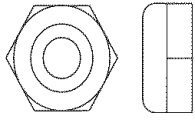

3/8" Nylon Jamnut (99)

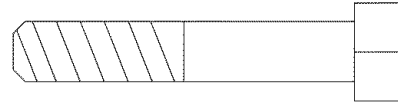

5/16" x 1 3/4" Bolt (24)

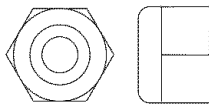

5/16" Nylon Locknut (3)

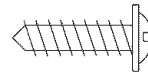

#8 x 1/2" Self-tapping Screw (87)

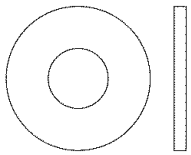

1/4" Washer (10)

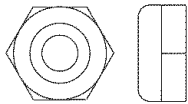

5/16" Nylon Jamnut (93)

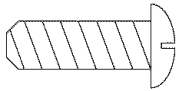

1/4" x 3/4" Screw (18)



1/4" Nylon Locknut (2)

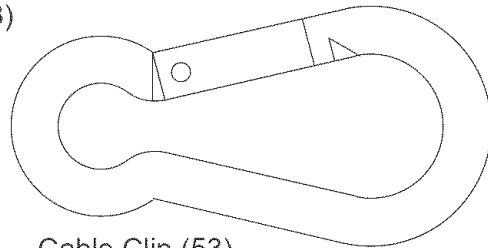

Cable Clip (53)

3/8" x 8" Bolt (59)

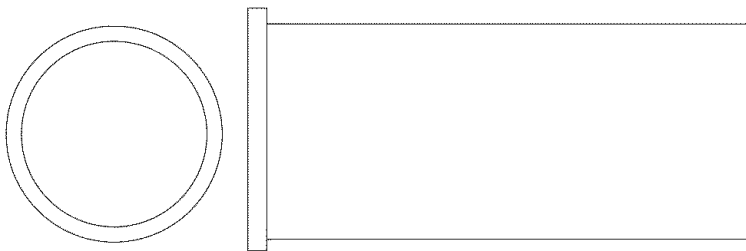

1 1/8" x 2 1/2" Plastic Bushing (89)

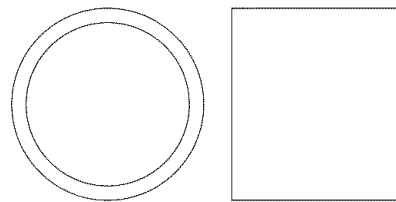

1" x 7/8" Plastic Bushing (90)

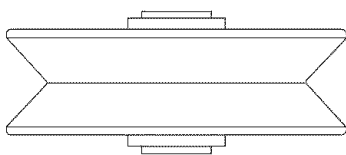

"V"-Pulley (50)
(Not shown to scale)

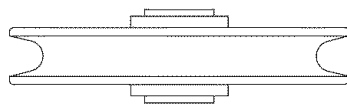

3 1/2" Pulley (15)
(Not shown to scale)

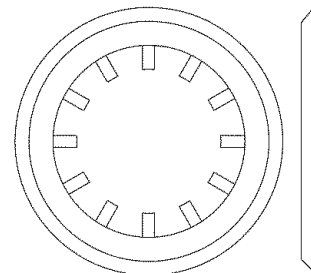

1" Retainer (69)

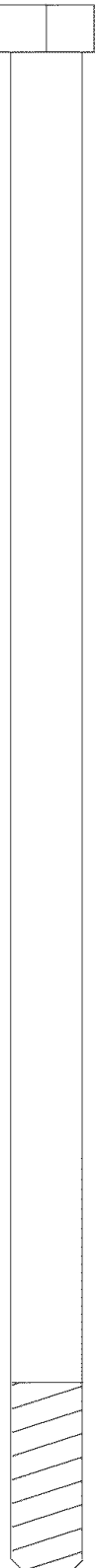

3/8" x 8" Bolt (59)

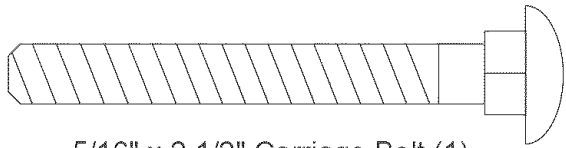

5/16" x 2 1/2" Carriage Bolt (1)

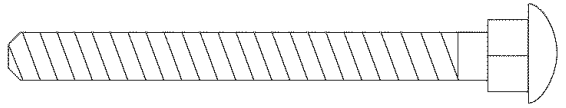

1/4" x 2 1/2" Carriage Bolt (91)

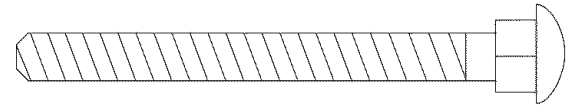

1/4" x 2 1/2" Carriage Bolt (92)

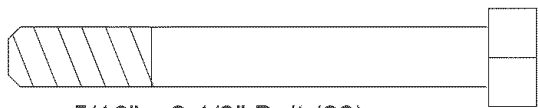

5/16" x 2 1/2" Bolt (22)

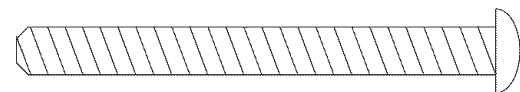

1/4" x 2 1/2" Screw (43)

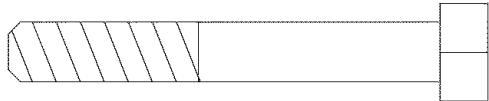

5/16" x 2 1/4" Bolt (33)

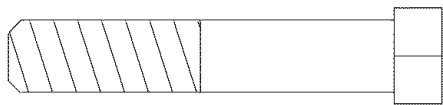

3/8" x 2" Bolt (12)

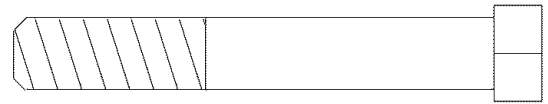

3/8" x 2 1/2" Bolt (86)



5/16" x 2 3/4" Bolt (11)



5/16" x 2 3/4" Carriage Bolt (14)

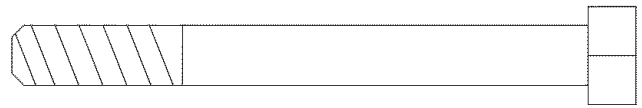

3/8" x 3" Bolt (100)

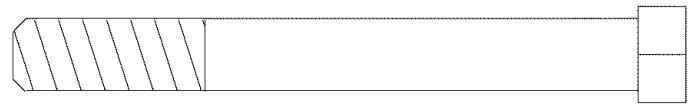

3/8" x 3 1/4" Bolt (67)

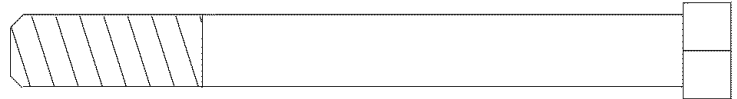

3/8" x 3 1/2" Bolt (16)

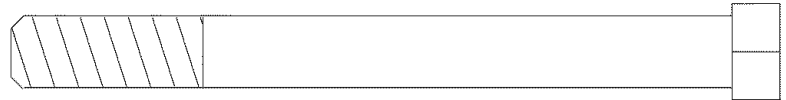

3/8" x 3 3/4" Bolt (88)

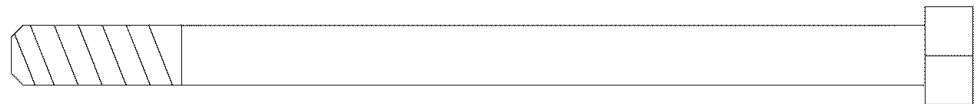

5/16" x 5" Bolt (68)

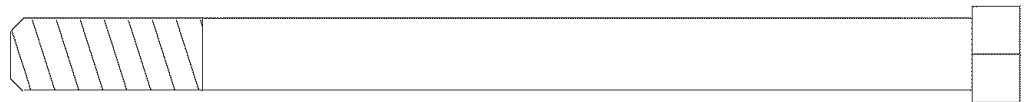

3/8" x 5" Bolt (101)

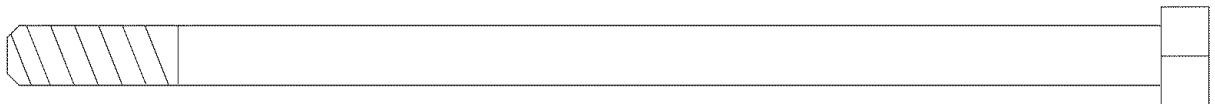

5/16" x 6" Bolt (60)

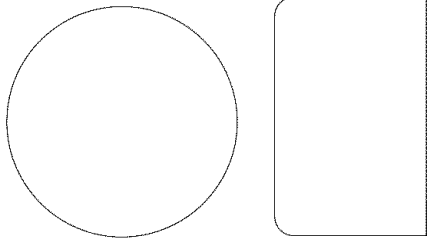

1" Round Cover Cap (70)

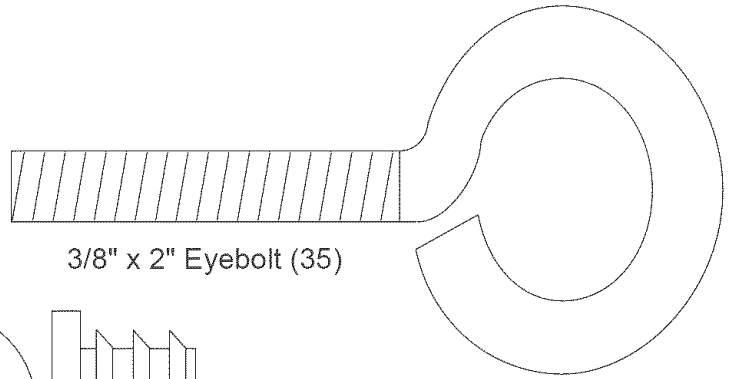

3/8" x 2" Eyebolt (35)

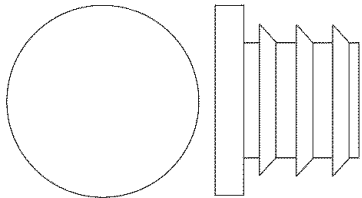

Round Inner Cap (75)

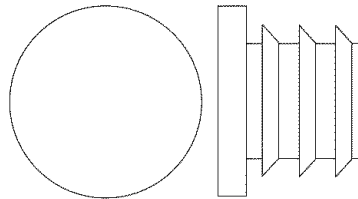

1" Round Inner Cap (49)

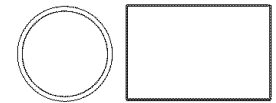

1/2" x 3/4" Spacer (61)

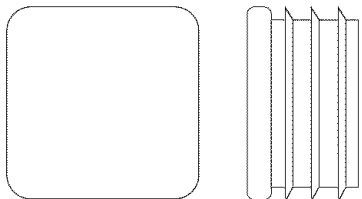

1" Square Inner Cap (6)

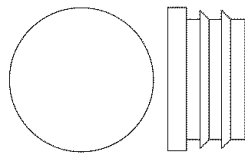

3/4" Round Inner Cap (34)

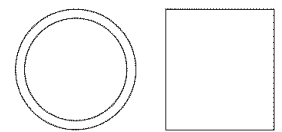

5/8" x 9/16" Spacer (7)

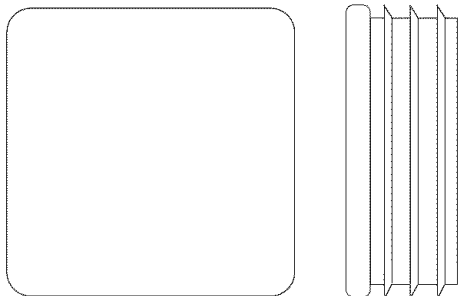

1 1/2" Square Inner Cap (32)

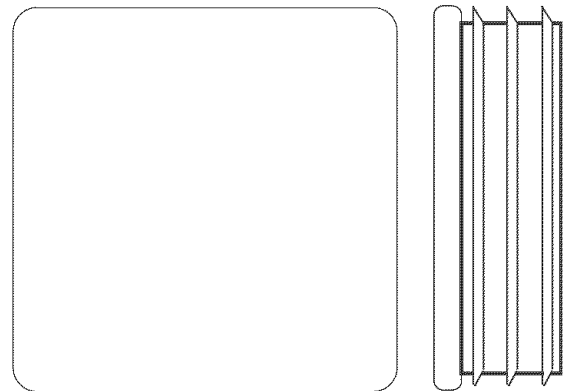

2" Square Inner Cap (27)

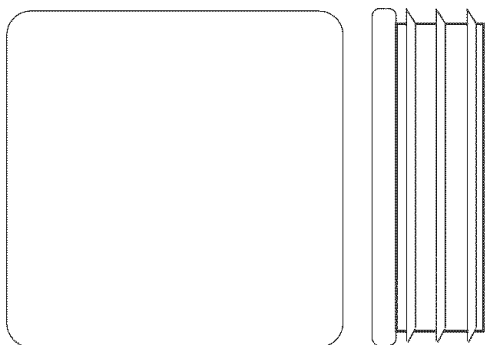

1 3/4" Square Inner Cap (44)

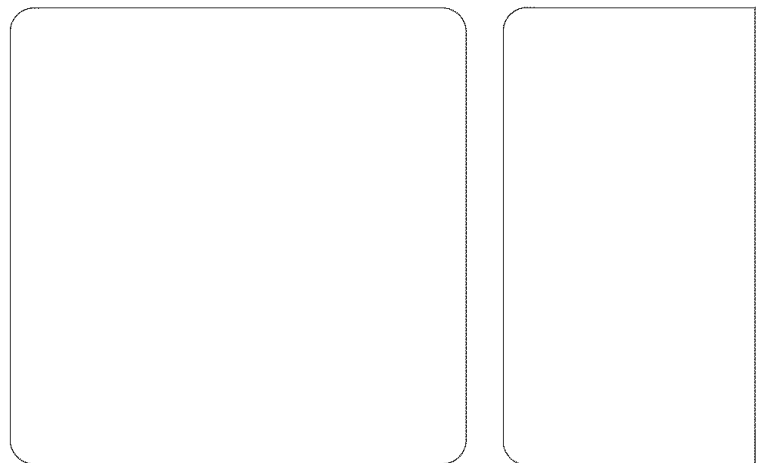

2" Square Outer Cap (51)

PART LIST—Model No. WESY39311

R0402A

Key No.	Qty.	Description	Key No.	Qty.	Description
1	10	5/16" x 2 1/2" Carriage Bolt	54	1	Lat Bar
2	6	1/4" Nylon Locknut	55	1	Top Frame
3	30	5/16" Nylon Locknut	56	1	Leg Press Upright
4	1	Base	57	2	Long "U"-Bracket
5	1	Stabilizer	58	1	High Cable
6	1	1" Square Inner Cap	59	1	3/8" x 8" Bolt
7	1	5/8" x 9/16" Spacer	60	2	5/16" x 6" Bolt
8	9	5/16" Washer	61	4	1/2" x 3/4" Spacer
9	8	3/8" Washer	62	2	Long Weight Guide
10	11	1/4" Washer	63	2	Weight Tube
11	9	5/16" x 2 3/4" Bolt	64	2	Weight Tube Bumper
12	8	3/8" x 2" Bolt	65	2	Top Weight
13	2	Seat	66	10	Cable Trap
14	1	5/16" x 2 3/4" Carriage Bolt	67	2	3/8" x 3 1/4" Bolt
15	16	3 1/2" Pulley	68	1	5/16" x 5" Bolt
16	1	3/8" x 3 1/2" Bolt	69	4	1" Retainer
17	1	Press Frame	70	2	1" Round Cover Cap
18	6	1/4" x 3/4" Screw	71	2	Small "U"-Bracket
19	4	Weight Bumper	72	1	Military Press Cable
20	1	Pulley Bracket	73	2	Short Weight Guide
21	22	3/8" Nylon Locknut	74	1	Rear Upright
22	4	5/16" x 2 1/2" Bolt	75	2	Round Inner Cap
23	1	Low Cable	76	1	3 1/2" Low Pulley
24	2	5/16" x 1 3/4" Bolt	77	2	Pulley Cover
25	16	Weight	78	1	Leg Press Cable
26	2	Weight Pin	79	1	Leg Press Seat Frame
27	8	2" Square Inner Cap	80	1	Pivot Arm
28	2	Pad Tube	81	1	1/4" x 2" Machine Screw
29	1	Leg Lever	82	1	Handle
30	4	Foam Pad	83	8	5" Plastic Grip
31	3	Long Cable Trap	84	1	Military Press Arm
32	4	1 1/2" Square Inner Cap	85	1	Leg Press Backrest
33	3	5/16" x 2 1/4" Bolt	86	3	3/8" x 2 1/2" Bolt
34	4	3/4" Round Inner Cap	87	1	#8 x 1/2" Self-tapping Screw
35	1	3/8" x 2" Eyebolt	88	6	3/8" x 3 3/4" Bolt
36	1	Front Seat Frame	89	2	1 1/8" x 2 1/2" Plastic Bushing
37	2	Seat Plate	90	2	1" x 7/8" Plastic Bushing
38	1	1/4" x 2" Carriage Bolt	91	1	Rubber Bumper
39	1	Nylon Strap	92	1	1/4" x 2 1/2" Carriage Bolt
40	1	Seat Knob	93	2	5/16" Nylon Jamnut
41	1	Front Backrest	94	1	Press Bracket
42	1	Front Upright	95	1	Leg Press Plate
43	4	1/4" x 2 1/2" Screw	96	1	Leg Press Arm
44	6	1 3/4" Square Inner Cap	97	1	Press Pin
45	2	10" Pad	98	2	Bushing
46	2	Press Arm	99	2	3/8" Nylon Jamnut
47	1	Left Arm	100	1	3/8" x 3" Bolt
48	1	Right Arm	101	1	3/8" x 5" Bolt
49	4	1" Round Inner Cap	102	2	Grip Pad
50	3	"V"-Pulley	103	1	Ab Strap
51	2	2" Square Outer Cap	#	1	User's Manual
52	1	Chain	#	1	Exercise Guide
53	3	Cable Clip			

Note: "#" indicates a non-illustrated part. Specifications are subject to change without notice.

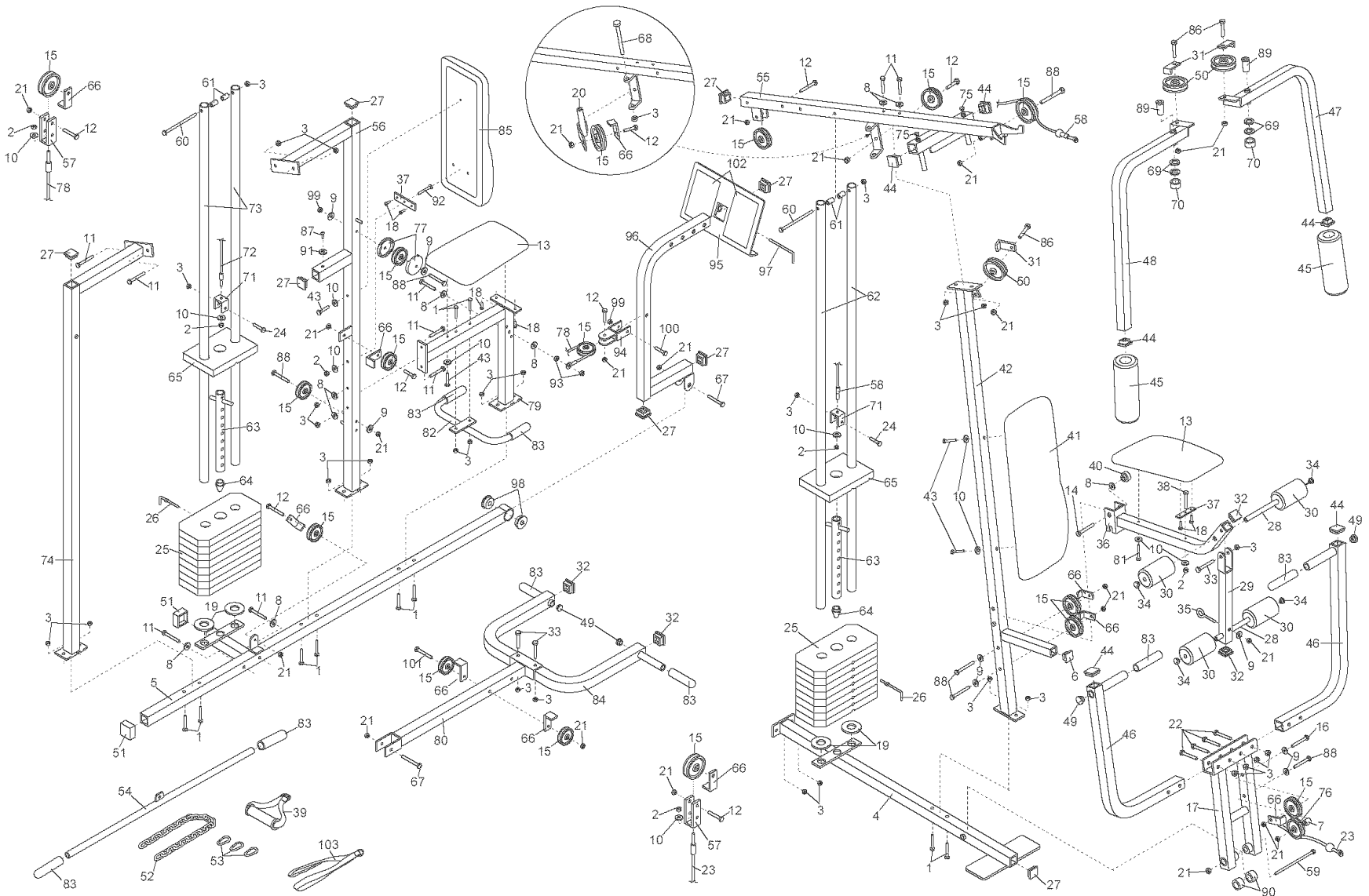

EXPLODED DRAWING—Model No. WESY39311

R0402A

ORDERING REPLACEMENT PARTS

To order replacement parts, call our Customer Service Department toll-free at 1-800-999-3756, Monday through Friday, 6 a.m. until 6 p.m. Mountain Time (excluding holidays). To help us assist you, please be prepared to give the following information:

1. The MODEL NUMBER of the product (WESY39311)
2. The NAME of the product (WEIDER® PRO 9400 weight system)
3. The SERIAL NUMBER of the product (see the front cover of this manual)
4. The KEY NUMBER and DESCRIPTION of the part(s) (see the PART LIST and EXPLODED DRAWING attached at the center of this manual).

LIMITED WARRANTY

ICON Health & Fitness, Inc. (ICON), warrants this product to be free from defects in workmanship and material, under normal use and service conditions, for a period of ninety (90) days from the date of purchase. This warranty extends only to the original purchaser. ICON's obligation under this warranty is limited to replacing or repairing, at ICON's option, the product through one of its authorized service centers. All repairs for which warranty claims are made must be pre-authorized by ICON. This warranty does not extend to any product or damage to a product caused by or attributable to freight damage, abuse, misuse, improper or abnormal usage or repairs not provided by an ICON authorized service center; products used for commercial or rental purposes; or products used as store display models. No other warranty beyond that specifically set forth above is authorized by ICON.

ICON is not responsible or liable for indirect, special or consequential damages arising out of or in connection with the use or performance of the product or damages with respect to any economic loss, loss of property, loss of revenues or profits, loss of enjoyment or use, costs of removal or installation or other consequential damages of whatsoever nature. Some states do not allow the exclusion or limitation of incidental or consequential damages. Accordingly, the above limitation may not apply to you.

The warranty extended hereunder is in lieu of any and all other warranties and any implied warranties of merchantability or fitness for a particular purpose is limited in its scope and duration to the terms set forth herein. Some states do not allow limitations on how long an implied warranty lasts. Accordingly, the above limitation may not apply to you.

This warranty gives you specific legal rights. You may also have other rights which vary from state to state.

ICON HEALTH & FITNESS, INC., 1500 S. 1000 W., LOGAN, UT 84321-9813