

GE Monogram®  
36" Bottom Mount  
Refrigerators

Custom  
Options Guide

and

Installation

Instructions

With Custom Panel Dimensions  
and Trim Kit Installation Instructions

These Monogram refrigerators are designed to be customized with decorator door and grille panels. Field installed panels are required.

Factory installed trim will accommodate 1/4" thick custom panels or optional Lexan® and stainless steel panel kits.

Optional trim kits allow an even broader range of custom appearance options.

*Read this booklet carefully to accomplish the desired appearance and to insure a trouble free installation.*

This booklet contains information and illustrations to demonstrate custom possibilities. Custom door and grille panel sizes vary to accommodate the kit being used. Dimensions for each application are included and can be faxed or sent to the cabinet manufacturer so that the panels can be constructed accurately.

Models:

ZIC36N RH

ZIC36N LH

Before you begin - Read these instructions completely and carefully.  
IMPORTANT - Save these instructions for local inspector's use.  
IMPORTANT - OBSERVE ALL GOVERNING CODES AND ORDINANCES.  
Note to Installer - Be sure to leave these instructions with the Consumer.  
Note to Consumer - Keep these instructions with your Use and Care Book for future reference.  
**This appliance must be properly grounded. See "Grounding the Refrigerator," page 12.**

If you have a question concerning the installation of this product, call the GE Answer Center® Consumer Information Service at 800.626.2000, 24 hours a day, 7 days a week.

If you received a damaged refrigerator, you should immediately contact your dealer or builder.

Proper installation is the responsibility of the installer. Product failure due to improper installation is not covered under the GE Appliance Warranty. See the Use & Care Guide for warranty information.

#### WARNINGS:

- Use this appliance only for its intended purpose.
- Immediately repair or replace electric service cords that become frayed or damaged.
- Unplug the refrigerator before cleaning or making repairs.
- Repairs should be made by a qualified service technician.

**For Monogram local service in your area,  
1-800-444-1845.**

**For Monogram service in Canada  
1-888-880-3030**

**For Monogram Parts and Accessories, call  
1-800-626-2002.**

### Contents

#### Design Information

Flush or Semi-Flush Enclosure Installations .....	3
Enclosure Cutout and Product Dimensions .....	3
Installation Examples, Between Base & Wall Cabinets .....	4
Installation at End-of-Run .....	4
Frameless Cabinets .....	4
Accessory Panel Kits .....	4
Models Available .....	5
Advance Planning Exterior Appearance Options .....	5
Trim Kit Descriptions .....	6

#### Custom Panel Dimensions

Product and Cutout Information .....	7
1/4" Thick Custom Panels or Panels Secured to 1/4" thick backing .....	8
3/4" Thick Panels with Supplied Handle, ZKTC36L or ZKTC36R .....	9
3/4" Thick Panels with Custom Handle .....	10
Side Panel or Filler Options .....	11

<b>Installation Instructions .....</b>	<b>12-17</b>
--	--------------

#### Trim Kits

ZGC2 Trim Kit, Grille Panel Frame Adjustment .....	18
ZKHC1 Trim Kit (for 1/4" Panels), Support for Custom Handles .....	19-21
ZKTC36L/ZKTC36R Trim Kit, 3/4" Custom Panels .....	22-27
ZKHTC1 Trim Kit (for 3/4" Panels), Support for Custom Handles .....	28-31
ZKHCSS1 Trim Kit (for 1/4" Panels), Tubular Stainless Steel Handles .....	32-35
ZKHTCSS1 Trim Kit (for 3/4" Panels), Tubular Stainless Steel Handles .....	36-38
ZFC1 Trim Kit, for side to side installation .....	39

### Advance Planning

#### Flush or Semi-Flush Enclosure Installations

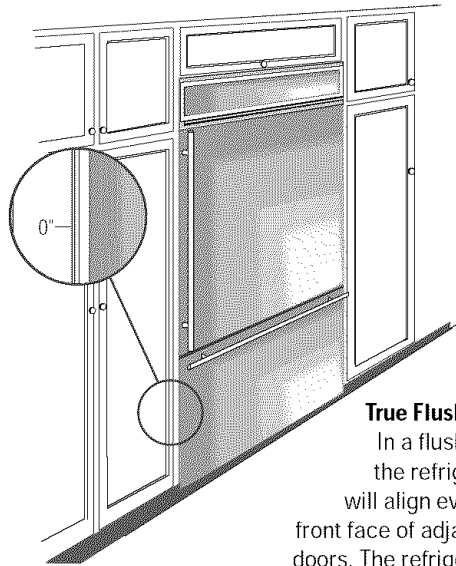

#### True Flush Installation

In a flush installation, the refrigerator doors will align evenly with the front face of adjacent cabinet doors. The refrigerator blends into the surrounding cabinetry.

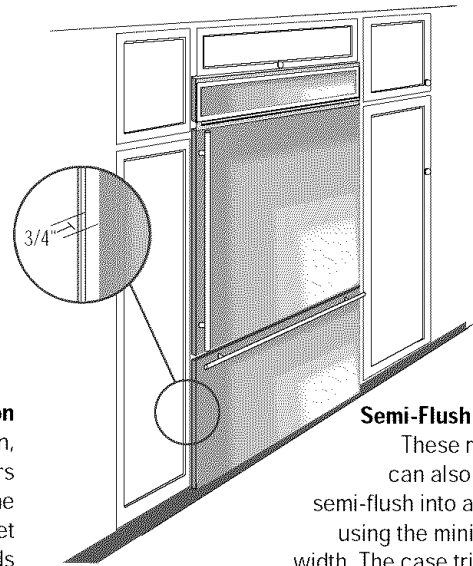

#### Semi-Flush Installation

These refrigerators can also be installed semi-flush into an enclosure using the minimum cutout width. The case trim creates a frame around the opening.

Monogram built-in refrigerators can be installed flush with typical 24-3/4" deep cabinetry.

When installed semi-flush, the case trim will conceal slight gaps around the enclosure. The refrigerator will project forward approximately 3/4" beyond the front face of surrounding cabinetry.

In any installation situation, a wide range of appearance options can be accomplished through the use of one or more trim kits. See trim kit descriptions and appearance options on page 6.

#### Side Panels Requirements:

- Side panels are not required whenever the refrigerator is installed into an enclosure or between pantry and oven cabinets.
- Side panels are required whenever the sides of the refrigerator are exposed.
- Side panel sizes vary depending on the type of installation being made.

#### To accomplish an attractive installation, you must:

1. Determine the need for side panels.
2. Determine side panel thickness.
3. Order matching side panels from the cabinet manufacturer. Be sure to provide the exact dimensions.

#### Enclosure Cutout and Product Dimensions

- To achieve a flush fit the finished cutout width must be at least 36" wide.
- A semi-flush installation requires 35-1/2" min. finished cutout width.
- The electrical and water locations must be located as shown for either type of installation.

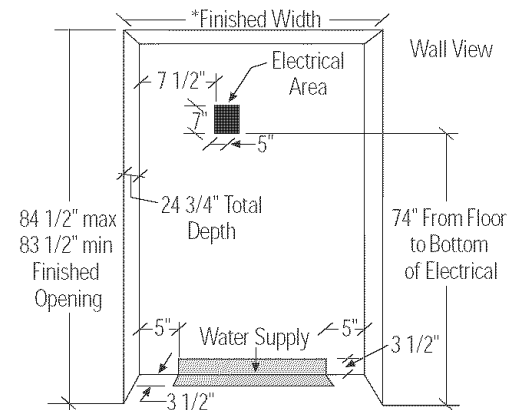
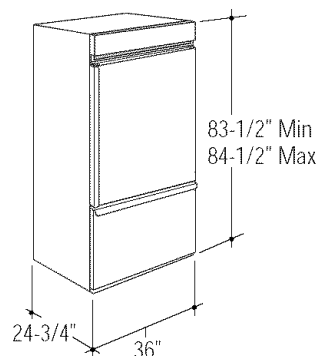

\*36" Min. for a flush installation

35-1/2" Min. for a semi-flush installation

Note: Additional cutout width may be required when side panels are used. Add side panel thickness to the finished cutout to calculate rough-in width. See installation examples on the following page.

# Design Information

## 36" Bottom Mount Refrigerators

### Installation Examples

Side panels are required whenever the sides of the refrigerator will be exposed.

1/2" to 3/4" side panels are normally set into place and fastened to adjacent cabinetry or to the back wall before rolling the refrigerator into the opening.

Therefore, the rough-in dimensions must allow for side panel thickness. In both a flush and semi-flush installation, the finished dimension, (the width of the opening after side panels are installed), must accommodate the full width of the refrigerator.

See page 11 for side panel sizes.

#### Installation Between Base & Wall Cabinets

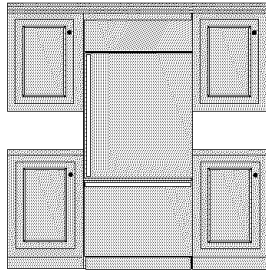

#### Flush and Semi-Flush Installations

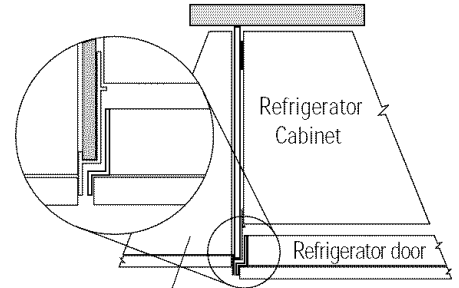
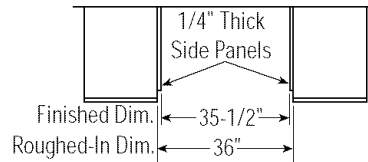

1/4" Side Panels. Insert end of side panel into trim

Note: 1/4" thick side panels can be inserted into the case trim, making the rough-in the same as the outside trim width, 36".

#### Installation At End-of-Run

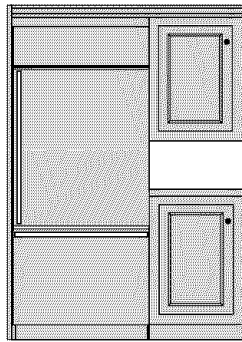

#### Flush and Semi-Flush Installations

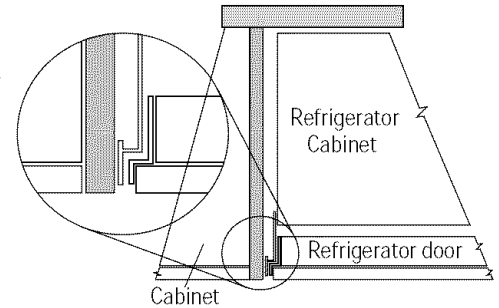
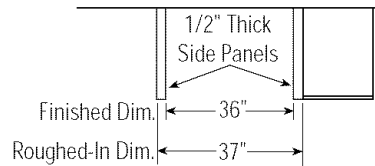

1/2" To 3/4" Side Panels. Leading Edge Flush With Cabinet

Note: 1/2" thick side panels shown. Side panels can be any thickness. Add side panel thickness to outside trim width (36") to calculate the rough-in dimension. The leading (front) edge must be finished to match surrounding cabinetry.

#### Frameless Cabinets

Side panels, 1/2" minimum thickness are required when using frameless cabinets. The side panel acts as a spacer between the cabinet and the case trim and prevents interference with cabinet door swing. The leading (front) edge must be finished to match surrounding cabinetry.

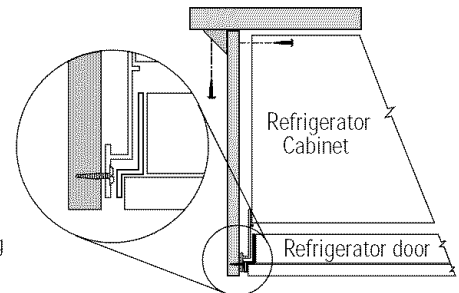

1/2" To 3/4" Side Panels. Leading Edge Flush With Cabinet

#### Accessory Panel Kits

These refrigerators require field installed door and grille panels. The factory installed trim will accept accessory panel kits. White or black Lexan® and stainless steel kits are available. Panels are cut to size and ready to install. These panel kits must be ordered separately.

A wide range of custom appearance options can be created with optional trim kits. See page 6 for examples and trim kit descriptions.

ZWBC36, Black Lexan® Panels  
 ZWWC36, White Lexan® Panels  
 ZWSC36, Stainless Steel Panels

# Design Information

## 36" Bottom Mount Refrigerator

### **Models available**

#### **ZIC36N RH**

36" wide model with handle on the left side, the door swings left to right.

#### **ZIC36N LH**

36" wide model with handle on the right side, the door swings right to left.

### **Advance planning exterior appearance options**

These refrigerators are designed to be customized with decorator door and grille panels. Field installed custom door and grille panels are required for these models.

Factory installed trim will accommodate 1/4" thick custom panels, Lexan® or stainless steel panel kits.

Door and grille panel sizes vary to accommodate the kit being used. Sizes are provided in this booklet.

Caution: Maximum panel weight for fresh food door is 50 pounds and 30 pounds for freezer drawer panel.

Side panels must be used whenever the sides of the refrigerator will be exposed. Side panel sizes vary depending on the installation.

#### **3/4" thick custom panels-Without trim kits**

A raised panel design, screwed or glued to a 1/4" thick backing can be used. See page 8 for panel sizes and clearances.

#### **You should:**

1. Select the appearance option.
2. Order the trim kit for that option.
3. Order the custom door and grille panels from the cabinet manufacturer. The exact dimension for each trim kit application is provided in this booklet. Find and pull out the page for your application and fax or send it to the cabinet manufacturer. The cabinet manufacturer must have this information to construct the panels accurately.
4. Determine the final installation situation and order matching side panels.

# Design Information

## 36" Bottom Mount Refrigerator

### Trim kit descriptions

**ZGC2** - Provides 1/4" grille panel frame side pieces for 83-1/2" and 84-1/2" installation heights. The supplied grille panel frame is factory set for 84".

**ZKHC1** - Provides the necessary framework to install custom handles, *of your choice*, onto 1/4" thick panels. (Handles not included.)

**ZKHCSI** - Tubular stainless steel handles for 1/4" thick panel installations.

**ZKHTC1** - Provides the necessary framework to install custom handles, *of your choice*, onto 3/4" thick panels. (Handles not included.) This kit must be used in combination with ZKTC36L or ZKTC36R

**ZKHTCSS1** - Tubular stainless steel handles for 3/4" thick panel installations. This kit must be used in combination with ZKTC36L or ZKTC36R

**ZKTC36L (left opening models), ZKTC36R (right opening models)** - Provides for the installation of 3/4" thick custom door and grille panels. This kit provides a standard handle to fit 3/4" thick panels.

**ZFC1 Trim Kit** - For side to side installation of 2 refrigerators. This kit provides a trim strip to cover the side case trim for a finished appearance.

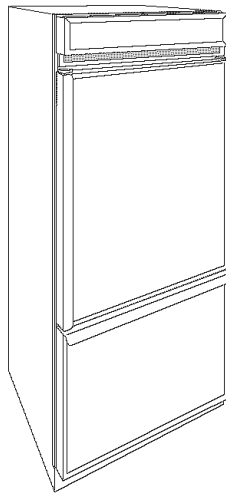

1/4" Panels with standard handles. No kits required.

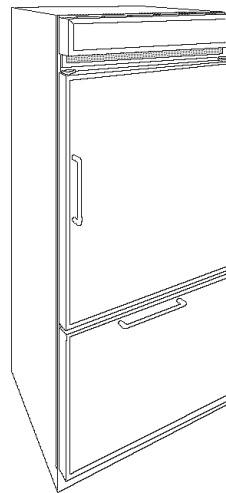

1/4" Custom panels with custom handles. Trim Kit ZKHC1.

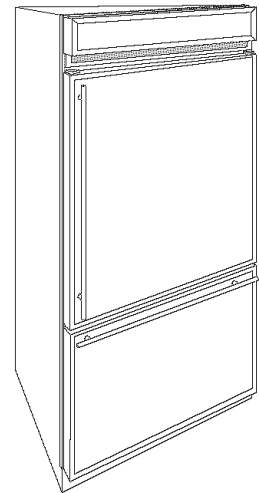

1/4" Custom panels with Tubular Stainless Steel handles, Trim Kit ZKHCSI.

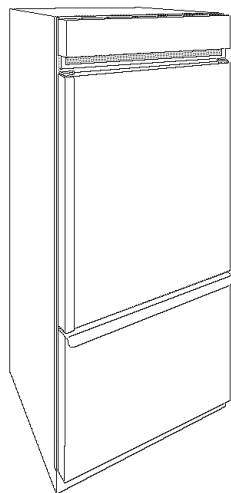

3/4" Custom panels with supplied handle. Trim Kit ZKTC36L (or ZKTC36R)

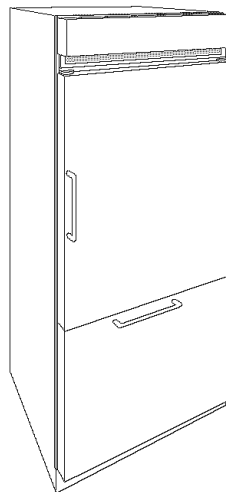

3/4" Custom panels with custom handles. Trim kits ZKTC36L (or ZKTC36R) and ZKHTC1.

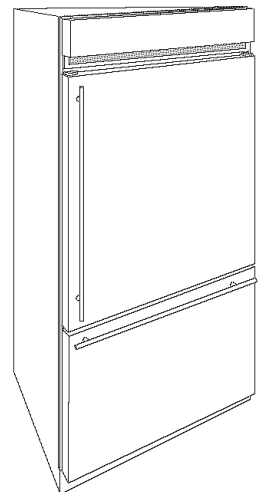

3/4" Custom panels with Tubular Stainless Steel handles, Trim Kits ZKTC36L (or ZKTC36R) and ZKHTCSS1

# Custom Panel Dimensions

## 36" Bottom Mount Refrigerators

### ZIC36N Bottom Mount Refrigerator

#### Design Information

Designed to be installed flush or semi-flush with surrounding cabinetry. Cutout dimensions, clearances and side panel sizes are determined by the many installation options available. Side panels must be used whenever the sides of the refrigerator will be exposed. Side panels are not required when refrigerator is installed into an enclosure or between pantry and oven cabinets. **IMPORTANT** - Side panels, 1/2" minimum thickness are required when using FRAMELESS CABINETS.

- Field installed custom panels, Lexan® or stainless steel panels are required. The door panels and grille panel sizes vary to accommodate the kit being used.
- The supplied toekick is vented and must remain unobstructed for proper air circulation.

#### Optional Panel Kits:

- ZWBC36: Black Lexan® Panel Kit
- ZWWC36: White Lexan® Panel Kit
- ZWSC36: Stainless Steel Panel Kit

#### Optional Custom Trim Kits:

- ZKHC1: For installation of a custom handle of your choice onto 1/4" Panels.
- ZKTC36L or ZKTC36R: For installation of 3/4" thick custom panels.
- ZKHTC1: For installation of a custom handle of your choice onto 3/4" thick panels. (This kit must be used in combination with ZKTC36L or ZKTC36R.)
- ZKHCSS1: Tubular Stainless Steel handles for 1/4" thick panels.
- ZKHTCSS1: Tubular Stainless Steel handles for 3/4" thick panels.
- ZGC2: 1/4" grille panel frame side pieces for 83-1/2" and 84-1/2" installation heights. Factory set height is 84".

#### Additional Specifications

- A 115 volt 60Hz, 15 or 20 amp power supply is required. An individual properly grounded branch circuit or circuit breaker is recommended. Install a properly grounded 3-prong electrical receptacle recessed into the back wall. Electrical must be located on rear wall as shown.
- Water line can enter opening through the floor or back wall. The water line should be 1/4" O.D. copper tubing between the cold water line and water connection location, long enough to extend to the front of the refrigerator. Installation of an easily accessible shut off valve in the water line is recommended.

#### Clearances:

- If the refrigerator is to be installed in a corner: A 4" clearance is required on the hinge side for a 90° door opening and access to fresh food drawers. A 10" clearance is required on the hinge side for removal of pans.

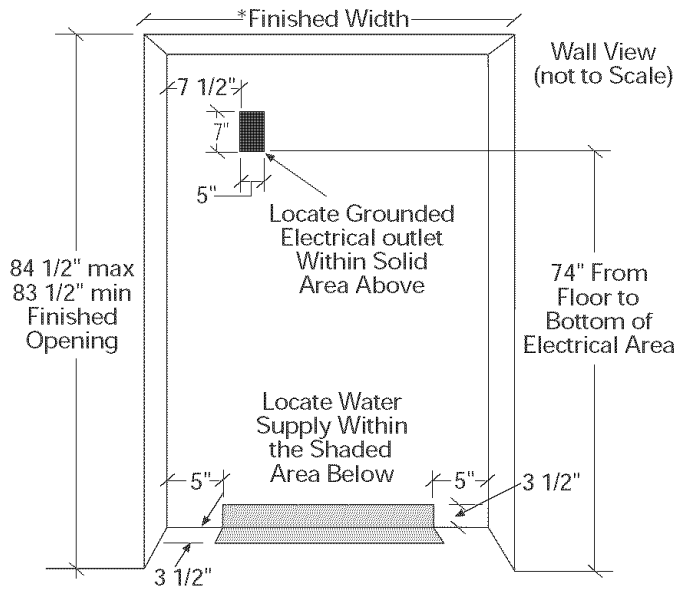
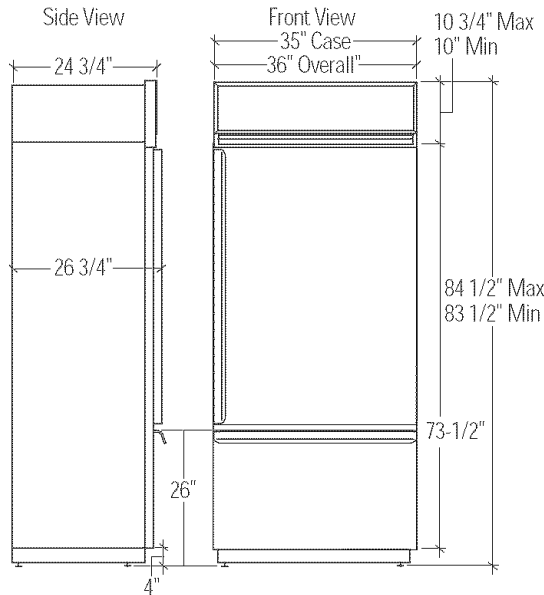

\* 36" Min. for a flush installation into an enclosure.

\* 35-1/2" Min. for a semi-flush installation into an enclosure.

Note: Additional cutout width may be required when side panels are used. Add side panel thickness to the finished cutout width to calculate rough-in width. See installation examples on page 4.

# Custom Panel Dimensions

36" Bottom Mount Refrigerators

## Custom Door Panel Dimensions Using Standard Trim 1/4" thick panels or Panels secured to 1/4" thick backing

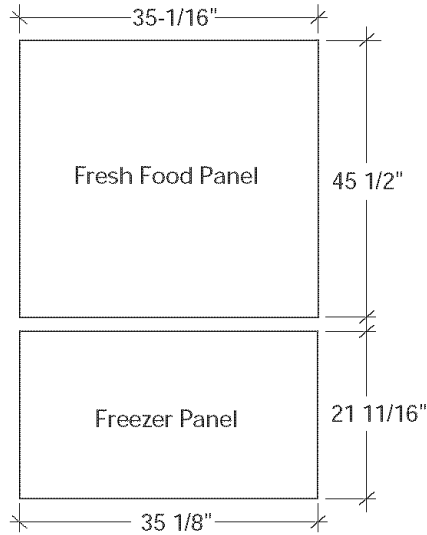

**Caution:** Maximum weight for fresh food panel is 50 pounds and 30 pounds for freezer drawer panel.

## ZIC36N Bottom Mount Refrigerator

- 1/4" Panels: Cut panels to size.
- Custom handles with 1/4" door panels require Trim kits ZKHC1 or ZKHCSS1 for tubular stainless steel handles).

## Standard Trim with Panels secured to 1/4" thick backing

- Applying a raised panel design to a 1/4" thick backing (screws or glued): Cut 1/4" thick panels to size. On the fresh food door, fabricate the raised panel to permit at least 2" fingertip clearance of the standard handle. 1-1/4" clearance from the hinge side to avoid striking adjacent cabinetry and 5/16" from the top and bottom edges to allow for the trim flange. For the freezer drawer, allow 2" clearance at the top handle end and 5/16" clearance on both sides and the bottom edge to allow for trim flange.

**Note:** ZKHTC1 custom handle kit cannot be used in this configuration.

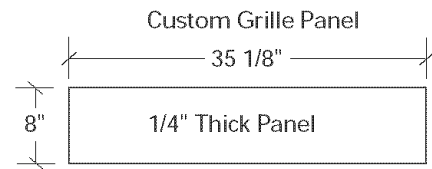

The grille panel frame is factory assembled for 84" installation height. If installation height varies, order ZGC2 trim kit that provides optional side trim pieces. Cut grille panel to sizes shown below.

Installation Height	Panel Height
83-1/2"	7-1/2"
84-1/2"	8-1/2"

## Raised Panel on 1/4" Thick Backing Using Standard Handles

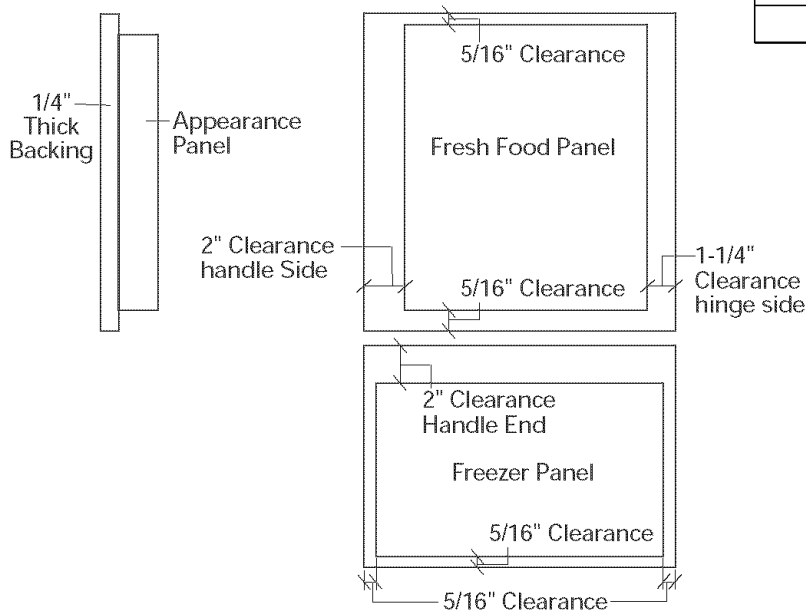



**Custom Door Panel Dimensions**  
**Using Trim Kits ZKTC36L or ZKTC36R**  
**3/4" thick panel with kit supplied handle**

**ZIS36N Bottom Mount Refrigerator**

- The ZKTC36L (or ZKTC36R) trim kit provides for the installation of 3/4" thick custom door and grille panels, using the supplied handle. Cut panels to size and install.

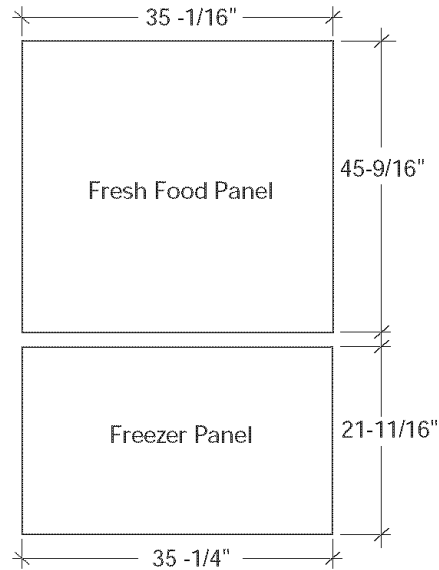

**Caution:** Maximum weight for fresh food panel is 50 pounds and 30 pounds for freezer drawer panel.

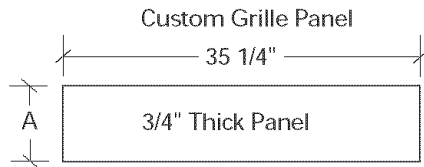

Grille Panel height can vary to fill installation height.

Installation Height	Dimension A
83-1/2"	7-3/4"
84"	8-1/4"
84-1/2"	8-3/4"

**Important:** Maintain 1-1/2" min. gap between top of door and bottom of grille panel.

**Custom Door Panel Dimensions Using Standard Trim  
Using Trim Kit ZKTC36L or ZKTC36R  
3/4" thick panel  
with custom handle**

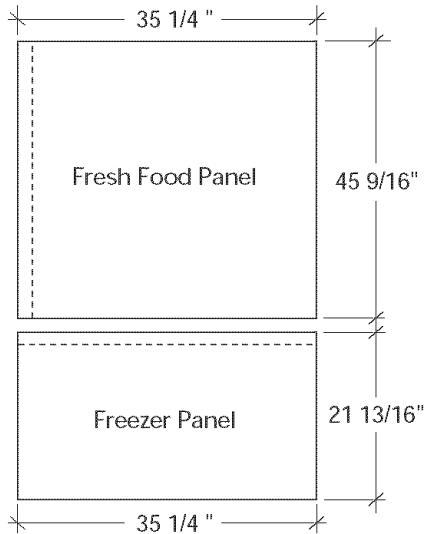

**ZIC36N Bottom Mount Refrigerator**

- The ZKTC36L (or ZKTC36R) trim kit installed together with a ZKHTC1 custom handle kit provides for the installation of 3/4" thick custom door and grille panels with a custom handle of your choice. Order ZKHTCSS1 for tubular stainless steel handles. Cut panels to size, rout the handle side of the panels as shown below and install.

**Caution:** Maximum weight for fresh food panel is 50 pounds and 30 pounds for freezer drawer panel.

Rout panels to specification below on the handle side of each panel

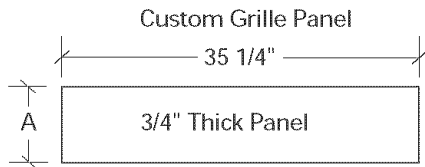
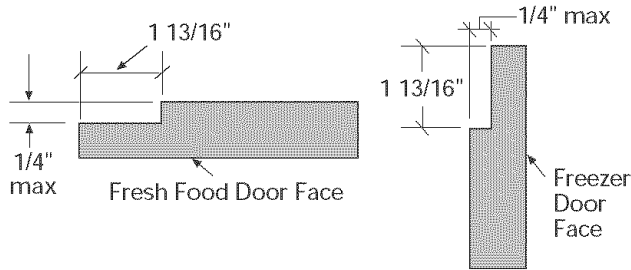

Grille Panel height can vary to fill installation height.

Installation Height	Dimension A
83-1/2"	7-3/4"
84"	8-1/4"
84-1/2"	8-3/4"

**Important:** Maintain 1-1/2" min. gap between top of door and bottom of grille panel.

### Side Panel or Filler Options

(Not to scale)

Side panels must be used whenever the sides of the refrigerator will be exposed.

**1/4" Side Panels**  
Insert end of side panel into trim.

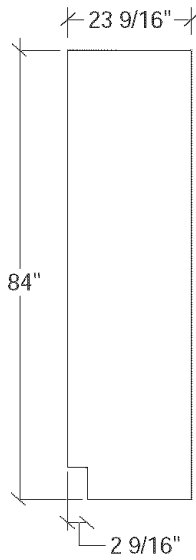
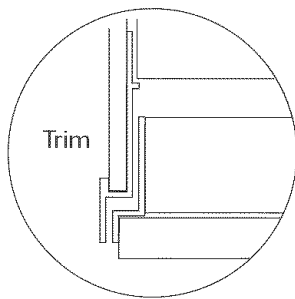

Standard 4" high toekick or trim to fit.  
Height may vary depending on application.

**1/2" to 3/4" Side Panels**  
Leading Edge  
Flush with Cabinet  
Front. The front or  
leading edge must be  
finished to match  
cabinetry.

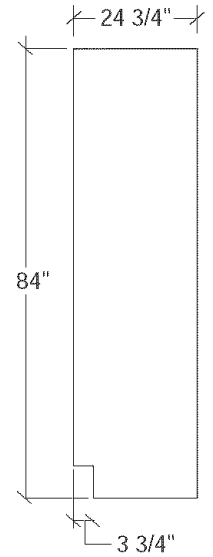
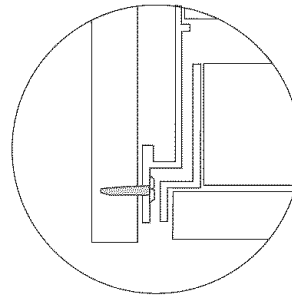

Standard 4" high toekick or trim to fit.  
Height may vary depending on application.

**1/2" to 3/4" Side Panels**  
Recessed front edge.

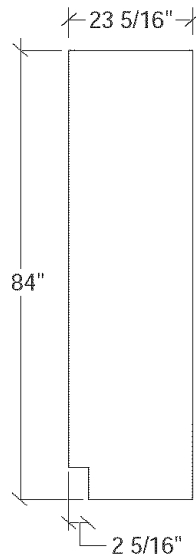
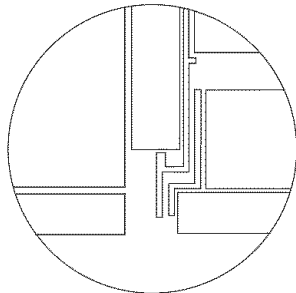

Standard 4" high toekick or trim to fit.  
Height may vary depending on application.

# Installation

## 36" Bottom Mount Refrigerator

### Tools Required

- Tinsnips to cut banding
- Stepladder
- Bucket
- Level
- Appliance Hand Truck
- Tubing cutter
- 7/16" open-end wrench
- #2 Phillips screwdriver
- Stubby Phillips screwdriver
- Drill and appropriate bits
- 7/16" socket with 3" extension for ratchet
- Safety glasses

### Materials Required

- Water shut-off valve (optional but recommended)
- Water filter WR97X0214 (optional but recommended)
- Custom panels for fresh food, freezer drawer, grille panel
- Side panels
- Hardware for side panel installation.
- 36" long 2x4 for Anti-Tip support

### Hardware Supplied

- 1-1/2" stamped open-end wrench
- Special Velcro adhesive strips for 1/4" side panels
- 1/4-1/4 union with nuts
- Anti-Tip Mounting Brackets

### Flooring

For proper installation, this refrigerator must be placed on a level surface of hard material that is at the same height as the rest of the flooring. This surface should be strong enough to support a fully loaded refrigerator.

**CAUTION:** Protect the finish of the flooring. Cut a large section of the cardboard carton and place under the refrigerator where you are working.

### Grounding the Refrigerator

IMPORTANT - (Please read carefully)

FOR PERSONAL SAFETY, THIS APPLIANCE MUST BE PROPERLY GROUNDED.

The power cord of this appliance is equipped with a three-prong (grounding) plug which mates with a standard three-prong (grounding) wall receptacle to minimize the possibility of electric shock hazard from this appliance.

Have the wall outlet and circuit checked by a qualified electrician to make sure the outlet is properly grounded.

Where a standard 2-prong wall outlet is encountered, it is your personal responsibility and obligation to have it replaced with a properly grounded 3-prong wall outlet.

DO NOT, UNDER ANY CIRCUMSTANCES, CUT OR REMOVE THE THIRD (GROUND) PRONG FROM THE POWER CORD.

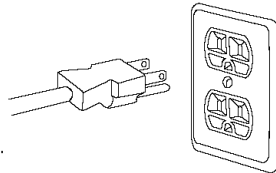

#### Use of Adapter plug

Because of potential hazards under certain conditions, we strongly recommend against use of an adapter plug. However, if you still elect to use an adapter, where local codes permit, a TEMPORARY CONNECTION, may be made to a properly grounded 2-prong wall outlet by use of a UL listed adapter available at most hardware stores.

The larger slot in the adapter must be aligned with the larger slot in the wall outlet to provide proper polarity in the connection of the power cord.

**CAUTION:** Attaching the adapter ground terminal to a wall outlet cover screw does not ground the appliance unless the cover screw is metal, and not insulated, and the wall outlet is grounded through the house wiring. You should have the circuit checked by a qualified electrician to make sure the outlet is properly grounded.

When disconnecting the power cord from the adapter, always hold the adapter in place with one hand and pulling the power cord with the other hand. If this is not done, the adapter ground terminal is very likely to break with repeated use.

Should the adapter ground terminal break, DO NOT USE the appliance until a proper ground has again been established.

#### Use of Extension Cords

Because of potential safety hazards under certain conditions, we strongly recommend against the use of an extension cord. However, if you still elect to use an extension cord, it is absolutely necessary that it be a UL listed 3-wire grounding type appliance extension cord having a grounding type plug and outlet and that the electrical rating of the cord be 15 amperes (minimum) and 120 volts.

# Installation

## 36" Bottom Mount Refrigerator

### Step 1 Remove Packaging

CAUTION: Refrigerator is much heavier at the top than at the bottom – be careful when moving. When using a hand truck, handle from side only.

- Remove outer carton.
    - Carefully cut banding at the top and bottom.
  - Slide out back corner posts (2).
  - Slide carton off top of cabinet.
- NOTE: IT IS NOT NECESSARY TO LAY CABINET DOWN IN ORDER TO REMOVE SKID!

- To remove skid, remove the four 7/16" bolts and their brackets.
- CAUTION: DO NOT ATTEMPT TO ROLL UNIT OFF SKID.
- There are support blocks on the bottom of the cabinet and door. They must be removed before sliding unit off skid or damage will occur.
  - Carefully, tilt cabinet and slide blocks out from beneath cabinet, slide unit off skid.
  - Remove toekick from the fresh food compartment, set aside for later installation.

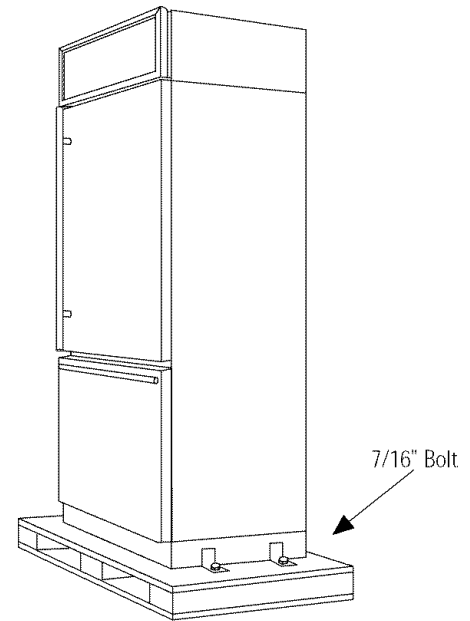

### Step 2 Install Water Line

- A cold water supply is required for automatic icemaker operation. The water pressure must be between 20 and 120 p.s.i.
- Route 1/4" OD copper tubing between house cold water line and the water connection location.
- Copper tubing should be long enough to extend to the front of the refrigerator. Allow enough to accommodate bend leading into the water valve.

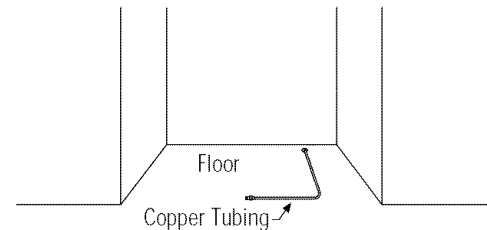

#### Shut off the main water supply.

Turn on the nearest faucet long enough to clear the line of water.

Install a shut-off valve between the icemaker water valve and cold water pipe in a basement or cabinet. The shut-off valve should be located where it will be easily accessible.

NOTE: It is best to install the valve into a vertical water pipe. If you install the valve into a horizontal water pipe, make the connection at the top or side, rather than at the bottom, to avoid drawing off any sediment from the water pipe.

- Drill a 1/4" hole in the water pipe.
- Fasten the shut-off valve to the pipe with pipe clamp.
- Tighten the clamp screws until the sealing washer begins to swell. Do not over tighten.
- Place a compression nut and ferrule (sleeve) onto the end of the tubing and connect it to the shut-off valve. Make sure the tubing is fully inserted into the valve and ferrule is tightened.
- Turn on the main water supply and flush debris from the line. Run about a quart of water through the tubing into a bucket. Shut off water supply at the shut-off valve.

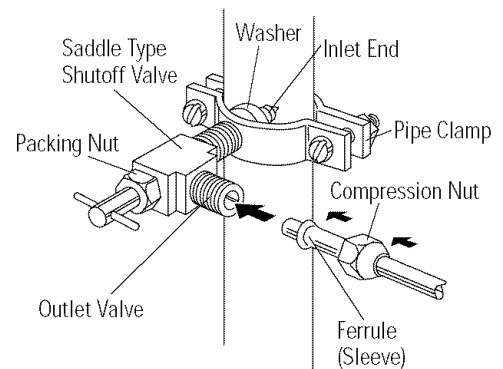

NOTE: Saddle type shut-off valves are included in many water supply kits. Before purchasing, make sure a saddle type valve complies with your local plumbing codes.

- Install optional water filter in the water line near the refrigerator. A water filter is recommended in areas where water supply contains sand or particles. Installation instructions are packed with the filter.

### Step 3 Install Side Panels

- Side panels are not required when the refrigerator is installed into an enclosure. Skip this step if you are installing into an enclosure.
- Side panels are required whenever the sides of the refrigerator will be exposed and when installed between frameless cabinets. See pages 3 and 4.
- Side panel installation will be determined by the design of the side panel you have previously chosen.
- Side panels must be installed plumb.
- If you choose to use 1/4" side panels, they should be inserted into the case trim as illustrated. Fasten the panels to the refrigerator with Velcro strips (provided) before setting refrigerator in place. See illustration A.
- 1/2" to 3/4" side panels are normally set into place and fastened to adjacent cabinetry or the back wall before rolling the refrigerator into the opening. See illustrations B and C.

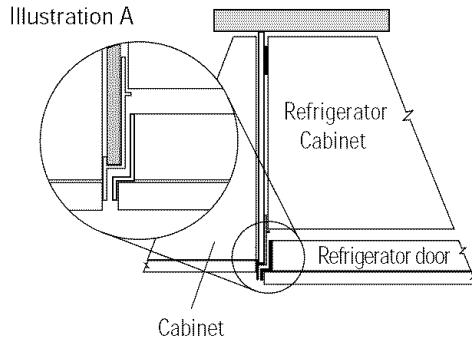

1/4" Side panels - Insert end of side panel into case trim. Fasten with Velcro strips provided.

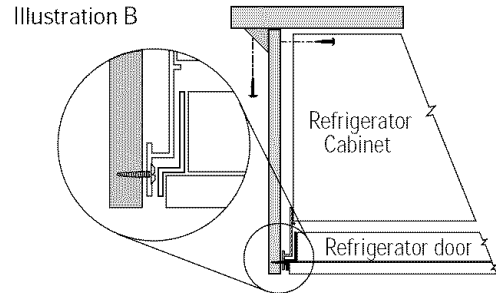

1/2" to 3/4" Side Panels - Leading edge of side panel is flush with cabinet front. Fasten to the back wall using a cleat.

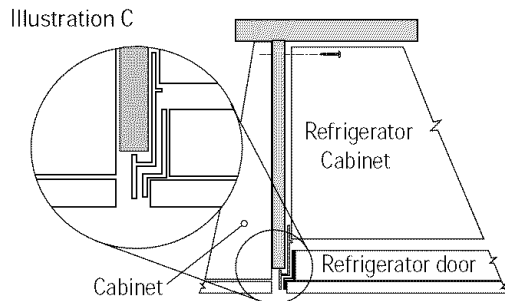

1/2" to 3/4" Side Panels - Recessed front edge of side panel. Fasten to adjacent cabinet.

### Step 4 Install Anti-Tip Brackets

**WARNING** **ANTI-TIP PRECAUTIONS**  
**The refrigerator is heavy at the top and must be secured to prevent the possibility of tipping forward.**

- Mount brackets provided using #12 or #14 wood screws located 83-1/2" from the finished floor.
- Screws must protrude at least one inch into vertical wall studs.
- Attach a 36" long 2x4 block to brackets as shown.

**Note:** If you are installing under a soffit, attach brackets to wood block before mounting the brackets to the rear wall.

#### Roll Refrigerator Into Opening

- Gently push refrigerator into opening with hands against front corners. The cardboard protective pad should be beneath the refrigerator.
- Roll refrigerator into the opening until it is flush or semi-flush with adjacent cabinets.

**Important Note:** If your installation situation does not allow enough height for this method of security, use step 6 as an alternate. **The refrigerator must be secured to prevent tipping.**

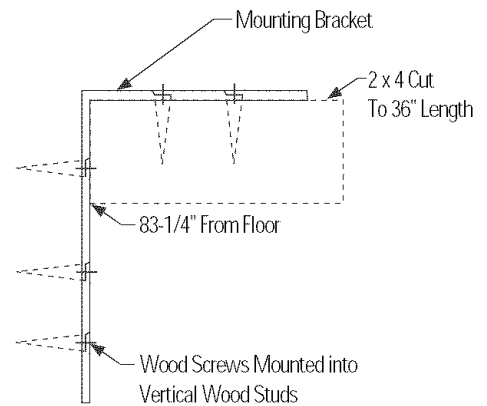
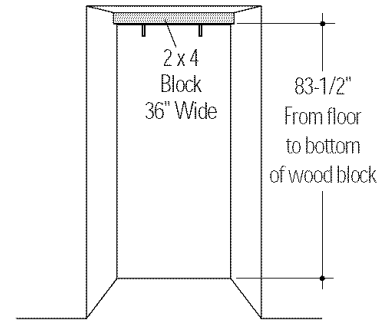

### Step 5 Level Refrigerator

All models have 4-point leveling. The front is supported by leveling legs, the rear is supported by wheels.

- Adjust rear wheels beneath the refrigerator to just barely touch the 2x4 block.
- Turn the 7/16" hex nut located above the front wheels. Turn to raise or lower the refrigerator.
- For front leveling legs, use the 1-1/2" open-end wrench (provided).
- Adjust carefully, the refrigerator should be level and plumb with cabinetry, and should align with toekick height.

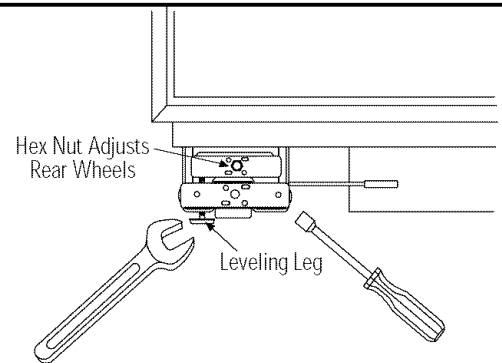

### Step 6 Optional Anti-Tip Precaution

**Note:** Whenever possible, perform this step for additional anti-tip security. This step can be used as an alternate to Step 4, Anti-Tip bracket installation, whenever brackets cannot be used.

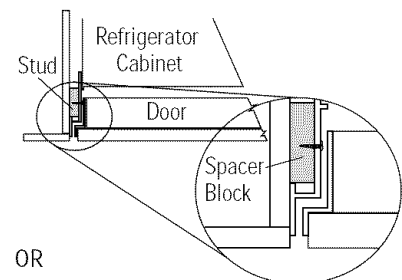
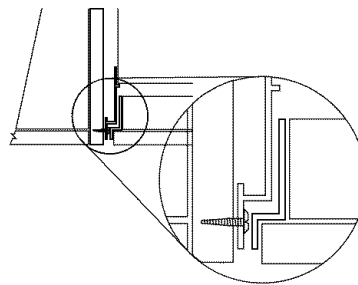

When using 1/2" to 3/4" side panels, the front flange of the case trim is attached to the side panel.

- Open fresh food door to access case trim.
- Drill hole in trim slightly below fresh food opening. Drive screw through the trim and into the side panel.
- Follow the same procedure on the opposite side.

If refrigerator is installed between cabinets with no side panels or in a custom enclosure, install a spacer block as shown.

- Open fresh food door to access case trim.
- Drill hole in trim slightly below fresh food opening and drive screw through the trim and into the spacer block.
- Follow the same procedure on the opposite side.

# Installation

## 36" Bottom Mount Refrigerator

### Step 7 Connect Water Supply

Check to be sure that refrigerator power cord is not plugged into the wall outlet.

- Locate and bring copper tubing to the front of the cabinet.
- The copper tubing should be just long enough to reach the coupling. Excess tubing length could interfere with drawer closing or toe kick installation.
- Slip a 1/4-1/4 union nut (provided) over both ends of the copper tubing at the right front leg of the refrigerator and couple the lines.
- Turn on the water to check for leaks.

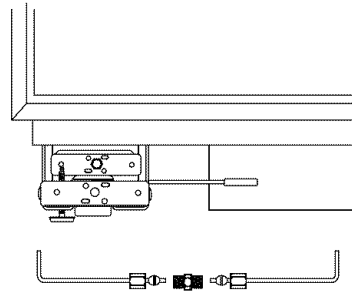

### Step 8 Install 1/4" door panels

If you are using 3/4" thick custom panels, SKIP THIS STEP. See Custom Panel Dimensions pages for panel sizes with ZKTC36L or ZKTC36R trim kit and other kits. Refer to trim kit installation instructions in this booklet.

#### Fresh food door panel:

- Open door to 90° stop. Remove the Phillips head screws from the aluminum trim door handle.
- Remove handle. Retain all screws.
- Slide custom panel into the door trim.
- Replace door handles and secure with original screws.

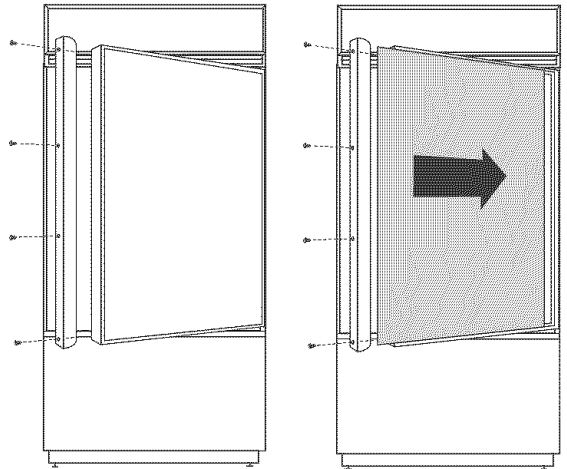

#### Freezer drawer panel:

- Slide freezer drawer out about half way.
- Remove the Phillips head screws from the aluminum trim door handle.
- Lift off handle. Retain screws.
- Slide custom panel into the drawer trim.
- Replace the drawer handle and secure with original screws.

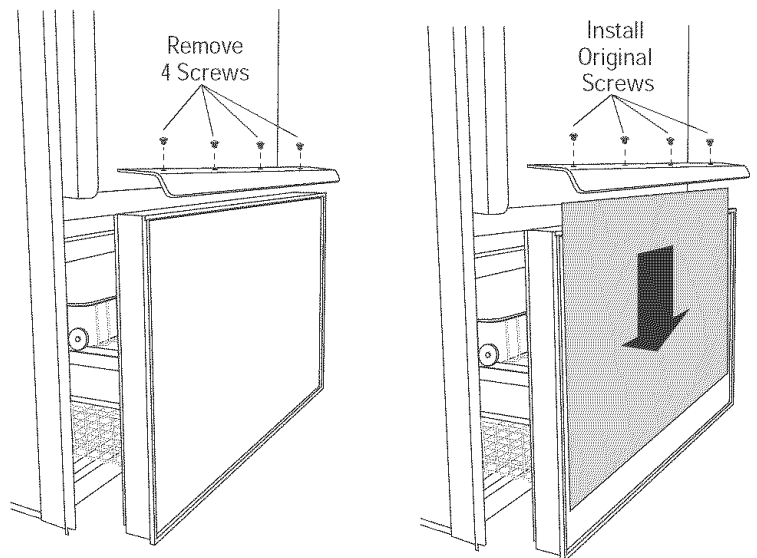



# Installation

## 36" Bottom Mount Refrigerator

### Step 9 Connect power

- Connect refrigerator power cord plug to a properly grounded receptacle, accessible through the top left side of the grille opening.
- Check to make sure power to refrigerator is on by opening refrigerator door to see if interior lights are on.

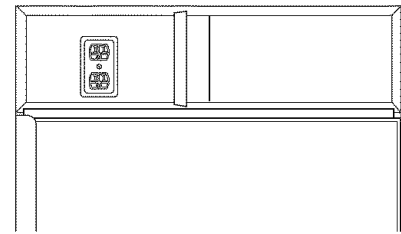

### Step 10 Mount Top Grille Panel

If you are using 3/4" thick custom panels, SKIP THIS STEP. See Dimensions and Specifications for grille panel sizes. Order ZKTC36L or ZKTC36R and follow the installation instructions packed with the kit.

The grille panel frame is factory assembled for an 84" installation height. If installation height varies, order ZGC2 trim kit which provides optional side trim pieces for 83-1/3" and 84-1/2" heights.

Cut 1/4" thick custom panel to fit the frame, 35-1/8" wide, 8" deep (for an 84" installation).

- For shipping purposes, the top case trim is secured at 84" installation height and must be adjusted.

#### To raise case trim to 84-1/2" or to lower to 83-1/2" installation height:

- Loosen 2 screws on both sides and raise the top or lower case trim to meet soffit height or to the top of adjacent cabinets.
- Tighten all 4 screws.

#### To insert custom grille panel into the frame:

- Remove screws (2 on each top corner) and "L" brackets on each side.
- Slide panel into the frame and reassemble.
- Mount the grille panel by dropping into slots on the case trim.

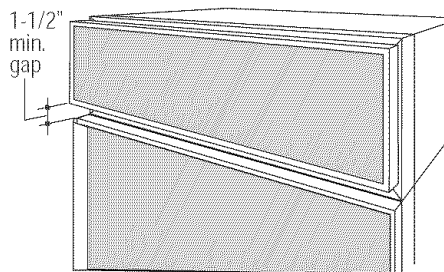
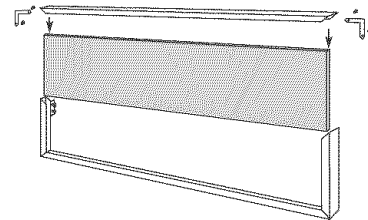
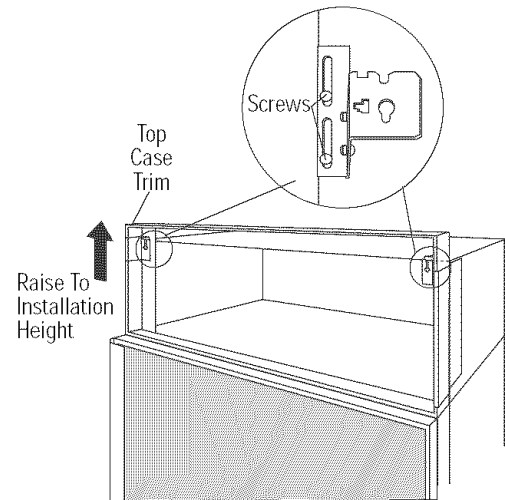

**Important:** Maintain 1-1/2" min. gap between top of doors and bottom of panel frame.

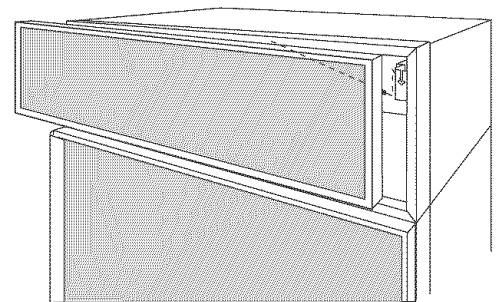

### Step 11 Install Toekick

- A standard toekick is supplied. Install with 2 screws provided, adjust to desired height and tighten screws.

**Important:** The vented toekick must remain unobstructed for proper air circulation and operation.

# ZGC2 Trim Kit

## Grille panel frame adjustment

This kit provides optional side trim pieces for the original grille panel frame to fit 83-1/2" and 84-1/2" installation heights.

To change grille panel size:

- Determine the installation height by measuring the enclosure from the floor to the underside of soffit. When there is no soffit, measure to the top of the adjacent cabinets.
- Adjust refrigerator case trim to desired height. See Product Installation.
- Select the side trim pieces for your installation height.

A. Locate original grille panel frame supplied with the refrigerator.

- Remove 8 screws (two on each corner) and "L" brackets as illustrated.

B. Select correct set of side trim pieces (2 sets provided).

- Secure new side trim pieces to original bottom trim.

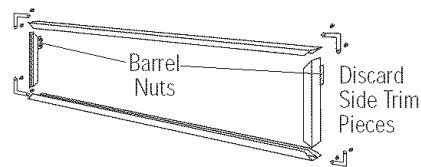

C. Remove barrel nuts from original side trim pieces (2 each side).

- Reinstall the barrel nuts on the new side trim pieces you have selected. Discard original side trim.

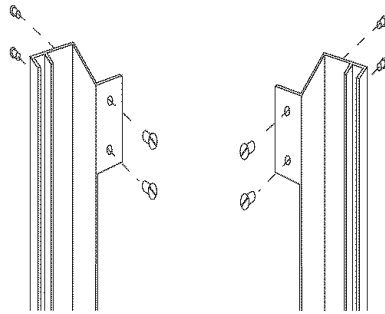

D. Slide custom panel into front slots.

- Secure the top trim piece to the frame with "L" brackets and screws.

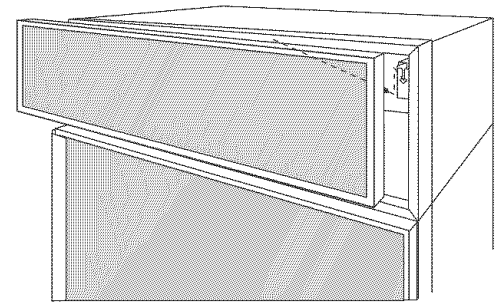
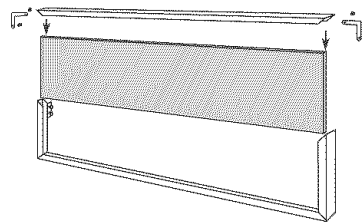

E. Mount the assembled panel by dropping into slots on the case trim.

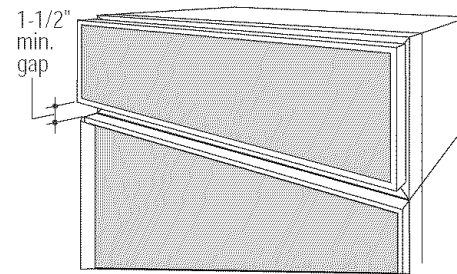

**Important:** Maintain 1-1/2" min. gap between top of door and bottom of grille panel.

# ZKHC1 Trim Kit (for 1/4" Panels)

*Support for custom handles*

Tools and materials required:

- #2 Phillips screwdriver
- Drill and appropriate bits
- Custom door panels
- Custom Handles
- Safety glasses

## Parts List:

- A. Fresh food door extrusion (for left hand models)
- B. Fresh food door extrusion (for right hand models)
- C. Freezer drawer extrusion

This kit provides the necessary framework to install custom handles, of your choice, onto 1/4" thick custom panels. (Handles not included.) The extrusions in this kit allow the custom handles to be secured to the door structure, rather than the door panels.

- Select fresh food extrusion for your model, discard other fresh food extrusion.

Right hand door swing models are illustrated in these instructions. Follow these instructions for left hand models.

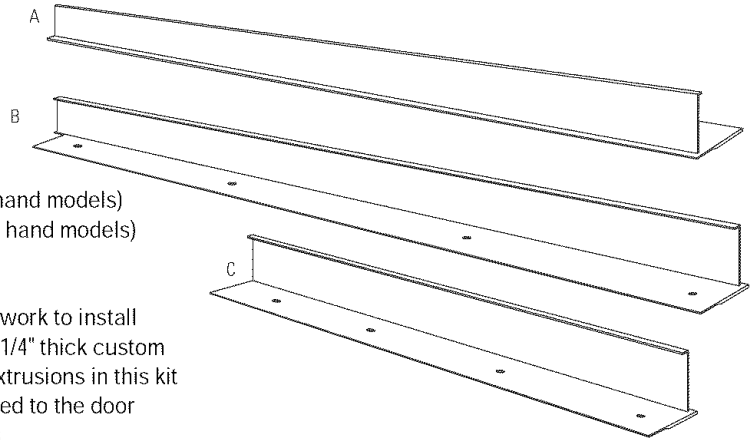

## Step 1 Remove handles

### Fresh food door:

- Open door to 90°. Remove the screws from the full length aluminum handle.
- Retain screws. Discard handle.

### Freezer drawer:

- Slide the freezer drawer open, about half way.
- Remove screws from the full-width aluminum handle.
- Retain screws. Discard handle.

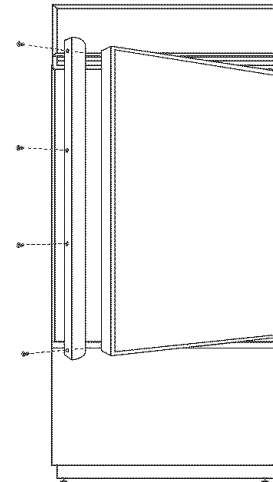
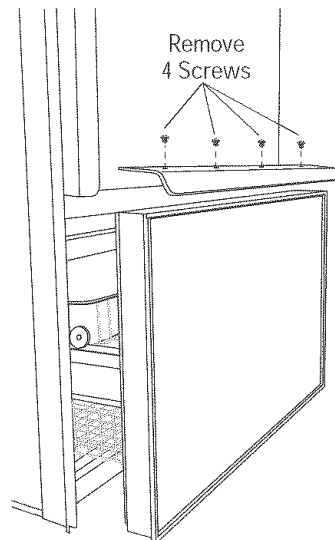

**Step 2  
Locate  
handle  
positions**

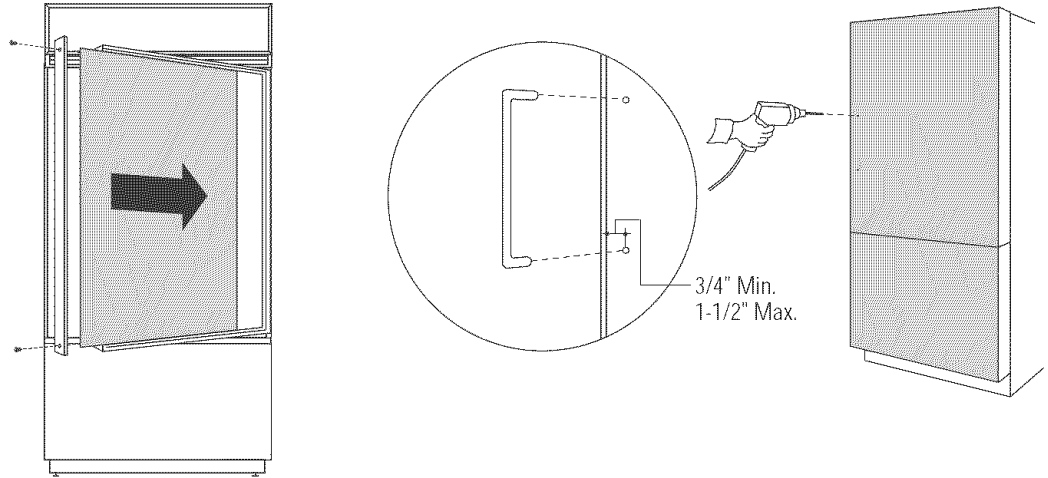

**Fresh food door:**

- Slide custom panel into the door trim.
- Temporarily secure the new handle extrusion to the door using at least 2 screws.
- The custom handles must be located 3/4" to 1-1/2" from the edge of the extrusion.

- Determine the desired location of the custom handle and mark centerlines of the screw holes.
- Drill 1/16" pilot hole through the panel until it starts into the aluminum extrusion. This will mark the matching location for drilling the clearance hole when assembling the handle, panel and extrusion.

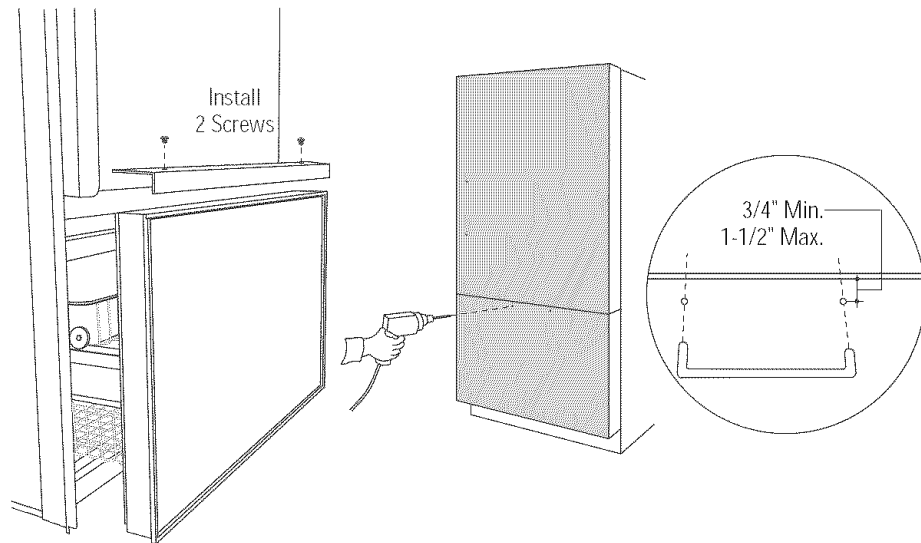

**Freezer drawer:**

- Slide custom panel into the freezer drawer trim.
- Temporarily secure the new handle extrusion to the drawer using at least 2 screws.
- The handle must be located 3/4" to 1-1/2" from the edge of the extrusion.
- Determine the location of the custom handle and carefully mark centerlines of the screw holes.
- Drill 1/16" pilot hole through the panel until it starts into the aluminum extrusion. This will mark the matching location for drilling clearance holes when assembling the handle, panel and extrusion.

**Step 3  
Assemble  
panel,  
extrusion and  
handle**

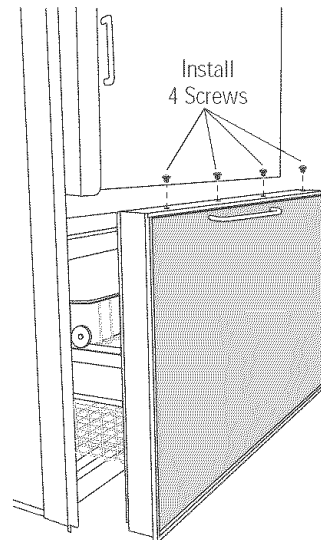
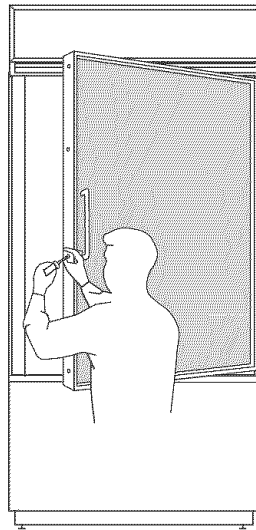
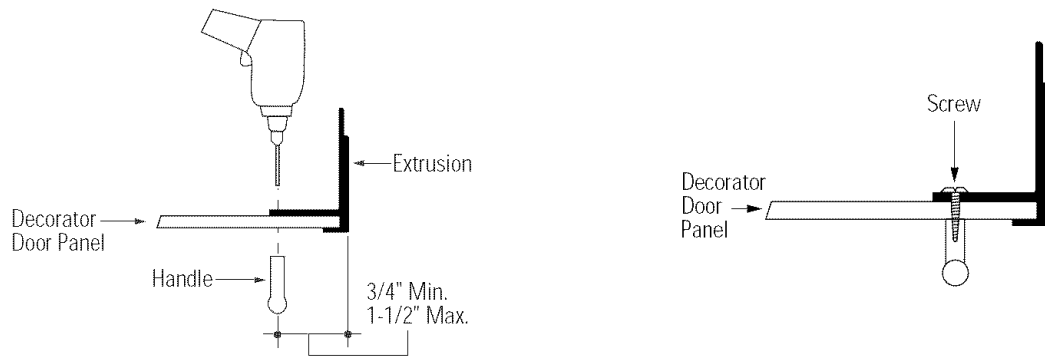

**Fresh food door:**

- Remove the door extrusion and custom panel.
- Drill 1/16" pilot hole through extrusion.
- Drill clearance holes through the panel and extrusion.
- Assemble the door panel, extrusion and custom handle.
- Install screw(s) long enough to pass through the extrusion, door panel and into the handle.
- Slide the assembly into the door frame until the new extrusion fits firmly against the steel door.
- Reinstall original screws into the door extrusion.

**Freezer drawer:**

- Remove the handle extrusion and panel.
- Drill 1/16" pilot hole through extrusion.
- Drill clearance holes through the panel and extrusion.
- Assemble the door panel, extrusion and custom handle.
- Install screws(s) long enough to pass through the extrusion, door panel and into the handle.
- Slide the assembly into the drawer trim until the new extrusion fits firmly against the steel drawer.
- Reinstall original screws into the extrusion.

# ZKTC36L/ZKTC36R Trim Kit

3/4" Custom Panels

## Kit Contents

Right hand door swing models are illustrated in these instructions. Follow these instructions for left hand models.

This kit provides for the installation of 3/4" thick custom door and grille panels. Handles are included and must replace the supplied handles.

### Tools and materials required:

- #2 Phillips screwdriver
- Drill and appropriate bits
- Custom door panels
- Putty knife
- Safety glasses

### Parts List

- A. Top trim
- B. Fresh Food Handle
- C. Hinge side trim
- D. Bottom trim
- E. Freezer Handle
- F. Side Trim
- G. Side Trim
- H. Bottom trim
- I. Support brackets for custom panels
- J. 4-3/8" screws for support brackets (20)
- K. Grille support panel and screws (6)
- L. Wood screws #6 1/2" flat head screws (30)

**Note:** If you are using custom handles, see ZKHTC1 installation instructions. For tubular stainless steel handles, see ZKHTCSS1 installation instructions.

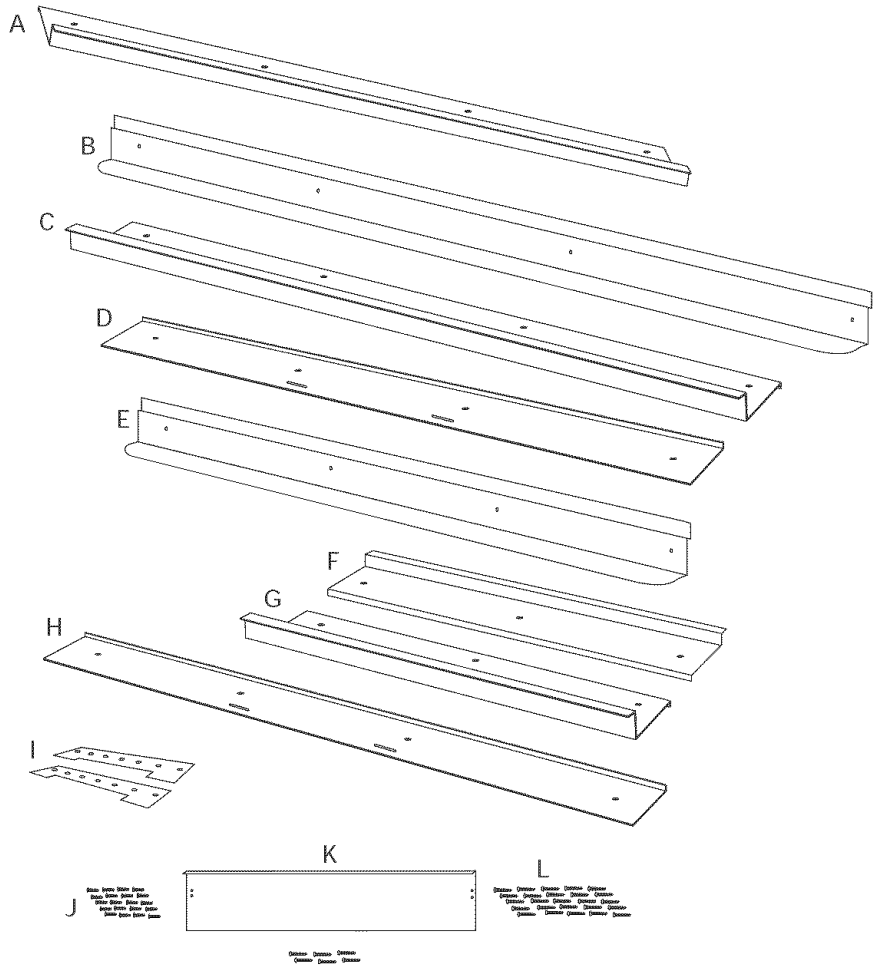

**Step 1**  
**Remove**  
**handles**  
**and trim**

**Fresh food door:**

- Open door to 90°.
- Remove the Phillips head screws from the full length handle, remove handle.
- Open the door fully to stop.
- Remove the screws from the aluminum trim, top bottom, hinge and handle side.
- Retain screws. Discard original trim and handle.

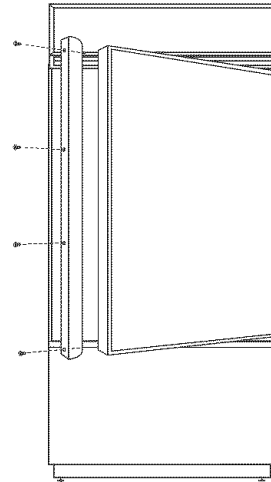

**Freezer drawer:**

- Slide the drawer fully open.
- Lift out top and bottom freezer baskets.
- There are 2 sets of 4 screws on the inside of the drawer door. Insert putty knife behind screw cover and snap off. Retain screw covers.
- Loosen all screws.
- Carefully, lift off entire drawer door.
- Place door on a protected surface, front side down. Take care not to bend switch plate on the bottom of the door.
- Remove light switch plate by backing out 3 Phillips head screws. Retain switch plate and screws.
- Turn the drawer over, front side up. Remove trim on both sides, bottom and handle. Retain all screws.

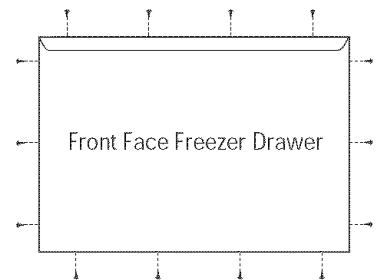
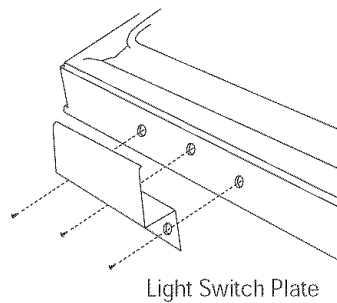
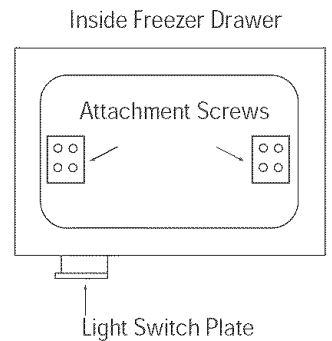
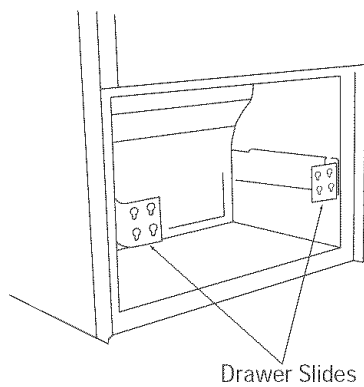

# ZKTC36L/ZKTC36R Trim Kit

3/4" Custom Panels

## Step 2 Install 3/4" trim

### Fresh Food Door:

- Attach the new 3/4" trim pieces on the top, hinge side and bottom using original screws.

### Freezer Drawer:

- Attach the new 3/4" trim pieces on the bottom and both sides.

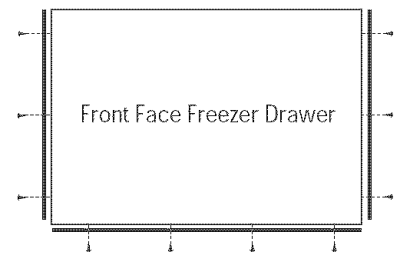
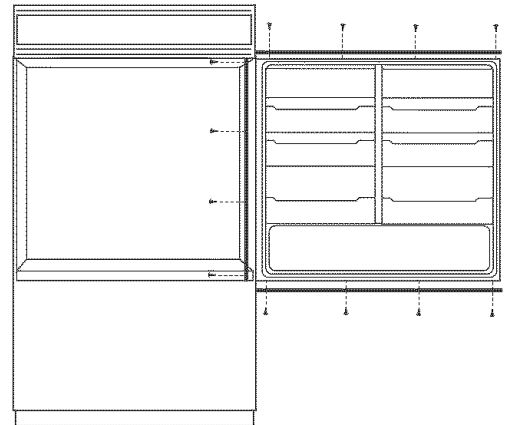

## Step 3 Apply panel support brackets

- Position support bracket on the back side of the fresh food panel, 14-5/16" from the hinge side. Secure support bracket to panel with screws provided.
- Position support bracket on the back side of the freezer drawer panel, 14-5/16" from the right side. Secure support bracket to panel with screws provided.

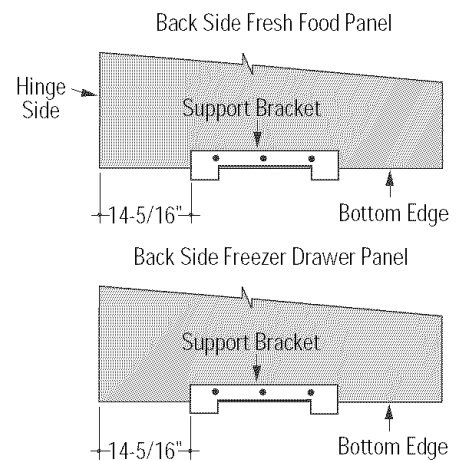



### Step 4 Install panels

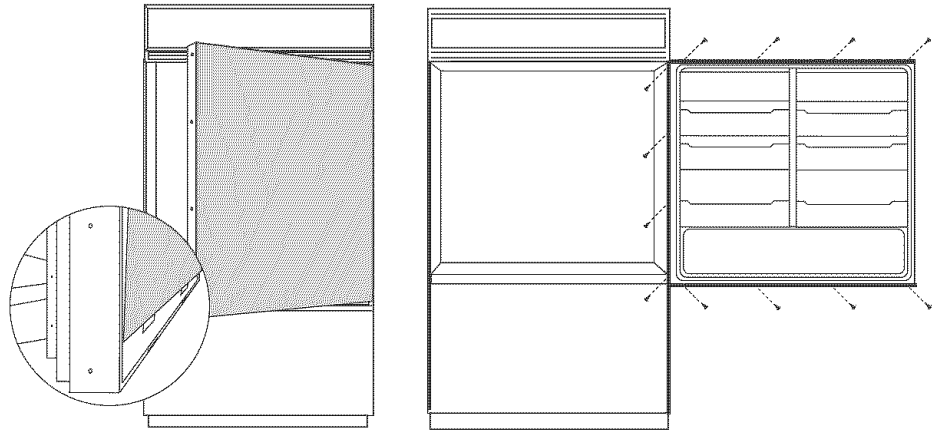

#### Fresh Food Panel:

- Place the 3/4" thick panel on the bottom trim with support bracket tabs inserted into slots. Push the panel back against the steel door, flush with hinge side trim.
- Open the door fully.
- Carefully drill 4 starter holes using a small drill bit, through the backside of the trim at the top.
- Install original screws through the trim and into the panel to secure the panel to the door.
- Drill 4 starter holes through the hinge side and 4 through the bottom trim. Install original screws.

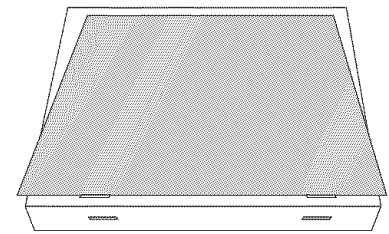

Insert support bracket tabs into slots on bottom trim

#### Freezer panel:

- Place the 3/4" thick panel onto the door with the support bracket tabs inserted into slots. The sides of the panel should be flush with trim on both sides.
- Turn door over, panel side down. Attach the panel to the sides and bottom by installing screws through the back of the trim and into the wood panel.
- Reinstall light switch plate to the bottom trim with original screws.

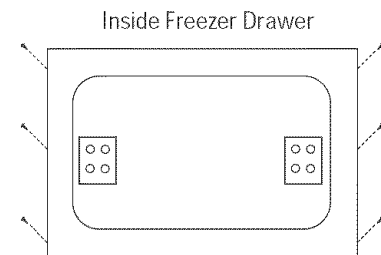

Inside Freezer Drawer

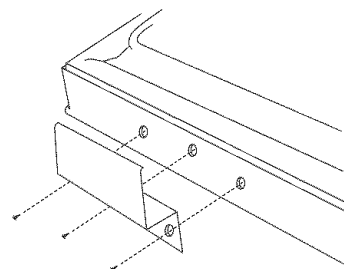

Light Switch Plate

# ZKTC36L/ZKTC36R Trim Kit

## 3/4" Custom Panels

### Step 5 Install handles

- Install new fresh food door handle using original screws.
- Place assembled drawer door onto freezer slides.
- Tighten screws and snap on screw covers.
- Install new freezer drawer handle with original screws.

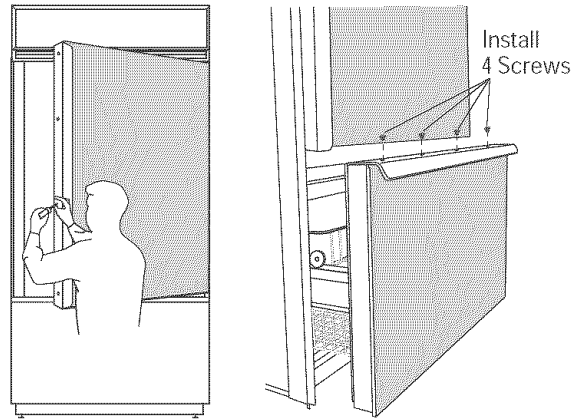

### Step 6 Adjust grille panel height

- For shipping purposes, the top case trim is secured at the 84" installation height.
- Loosen 2 screws on both sides of the case trim and raise or lower trim to meet soffit height, from 83-1/2" to 84-1/2".
- Tighten all 4 screws.

**Important:** Maintain 1-1/2" min. gap between top of door and bottom of grille panel.

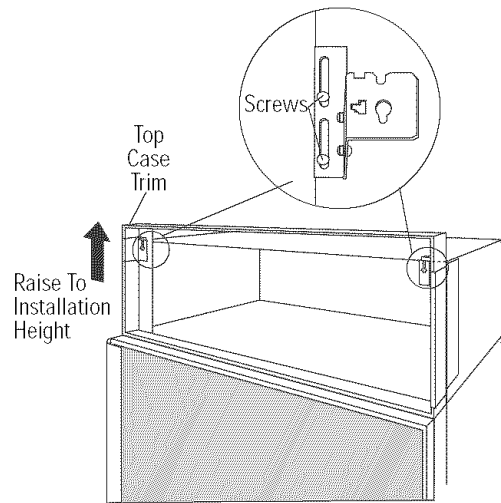

### Step 7 Secure 3/4" panel to grille panel support

- Secure the grille panel support to the back side of the 3/4" custom panel with #6 screws.
- Be sure the lip of the support is over the top of the wood panel.

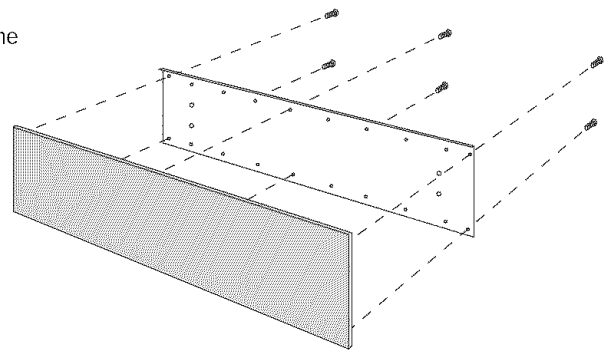
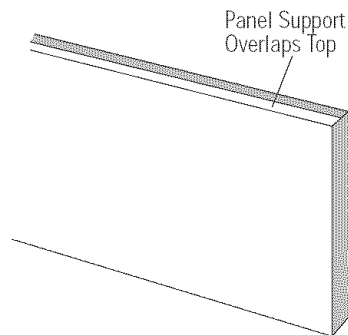

# ZKTC36L/ZKTC36R Trim Kit

*3/4" Custom Panels*

## **Step 8** **Install** **grille panel**

- Install four of the six larger undercut screw so that the top of the screws are 1/16" from the surface of the support.
- Attach the assembled panel to the refrigerator by inserting the four protruding screws into the brackets on each side of the grille opening.

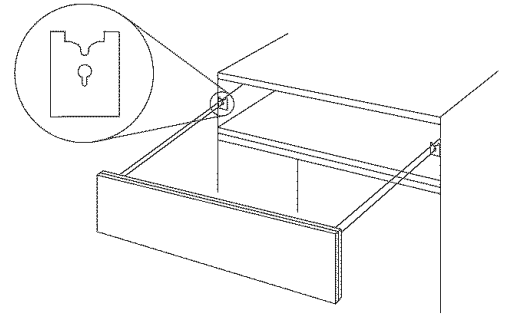
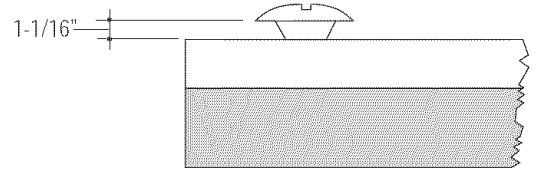
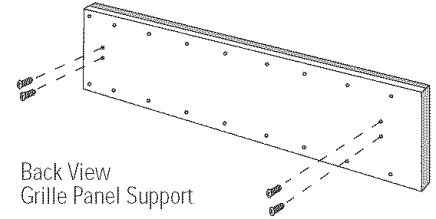

# ZKHTC1 Trim Kit (For 3/4" Panels)

*Support for Custom Handles*

## Kit Contents

Right hand door swing models are illustrated in these instructions. Follow these instructions for left hand models.

### Tools and materials required:

- #2 Phillips screwdriver
- Drill and appropriate bits
- Custom door panels
- Custom handles
- Safety glasses

**Note:** This kit must be used in combination with ZKTC36L or ZKTC36R trim kit for 3/4" panel trim.

### Part List:

- A. Fresh food handle extrusion (for left hand models)
- B. Fresh food handle extrusion (for right hand models)
- C. Freezer drawer extrusion

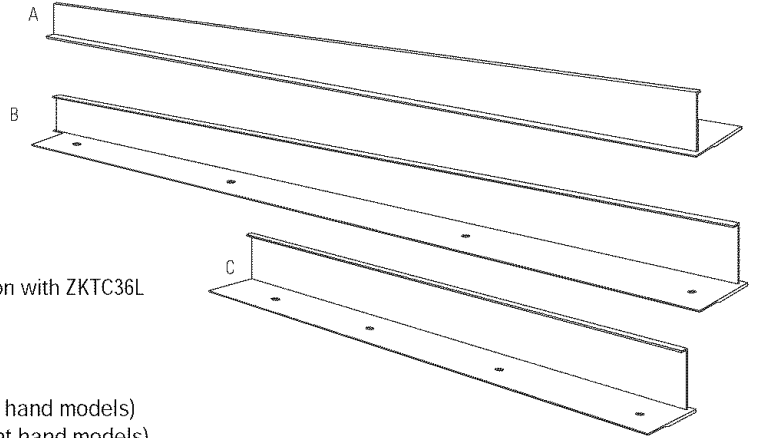

This kit provides the necessary framework to install custom handles, *of your choice*, onto 3/4" thick decorator door panels. (Handles not included.) The door extrusions allow the custom handles to be secured to the door structure, rather than the door panels.

- Select fresh food handle extrusion for your model, discard other fresh food extrusion.

## Before you begin

3/4" custom door panels must be routed to accommodate these door handle extrusions. Rout the panels as illustrated, 1/4" deep, and 1-13/16" wide on the handle side of the fresh food panel and the top end of the freezer panel.

Refer to installation instructions for ZKTC36L or ZKTC36R trim kit for 3/4" custom panels:

- Follow Step 1 to remove the standard aluminum trim.
- Follow Steps 2 and 3 to attach new 3/4" trim pieces and to install panel support brackets.

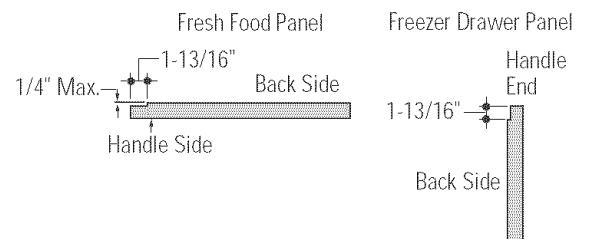

**Caution:** Optimal final appearance depends on careful routing depth. Do not exceed 1/4" routing depth

### Step 1 Temporarily mount door panels

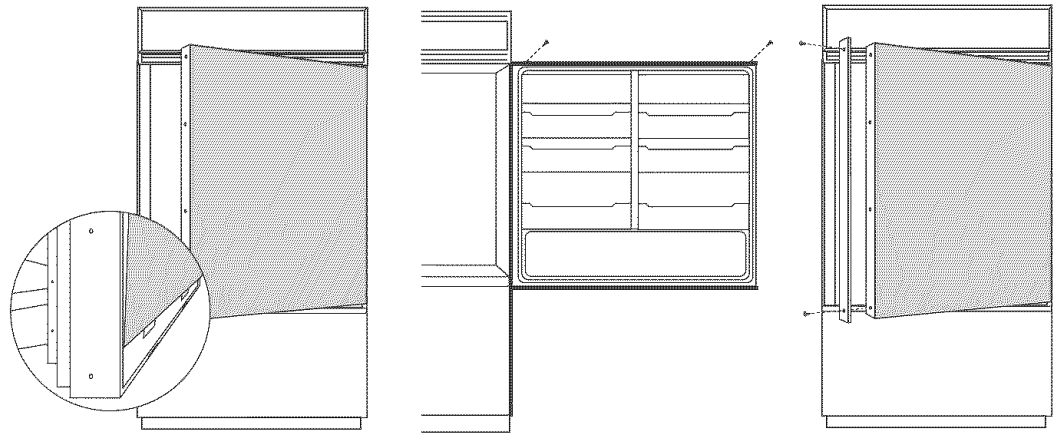

#### Fresh food door:

- Place the prepared 3/4" custom door panels on the bottom trim with support bracket tabs inserted into trim slots.
- Push the panel back against the steel door, making sure the panel is flush with the hinge side trim.
- Secure the panel to the trim temporarily by driving 2 screws through the backside of the trim at the top.
- Slide the handle extrusion in between the panel and steel door.
- Temporarily secure the extrusion to the door with 2 screws.

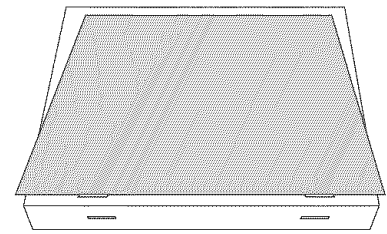

Insert support bracket tabs into slots on bottom trim

**Note:** The freezer drawer door should be removed as shown in the installation instructions for the ZKTC36 kit. Follow the instructions in Step 1 to remove the door.

#### Freezer drawer:

- Place the prepared 3/4" custom panel on the bottom trim with support bracket tabs inserted into the trim slots. The panel should be flush with trim on both sides.
- Secure the panel to the trim temporarily by driving one screw through the back side of each side trim.
- Temporarily mount the assembled drawer door onto the drawer slides. This will help to determine the handle location.

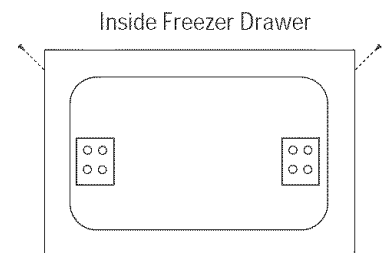

Inside Freezer Drawer

**Caution:** Be careful not to bend light switch plate on the bottom of the door.

- Slide the handle extrusion in between the panel and steel door.
- Temporarily secure the extrusion to the door with 2 screws.

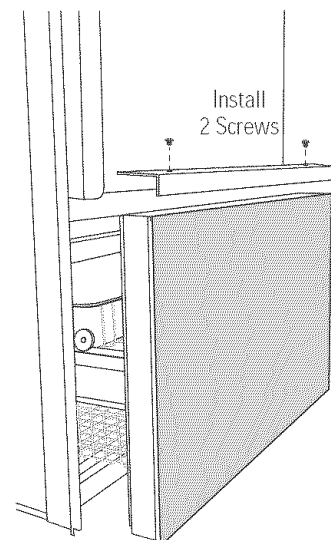

Install 2 Screws

**Step 2**  
**Locate**  
**position**  
**of handles**

**Fresh food door:**

- Determine the location of the custom handles and carefully mark centerlines of the screw holes. The handles must be located 3/4" to 1-1/2" from the edge of the extrusion.
- Drill 1/16" pilot hole through the panel until it starts into the aluminum extrusion. This will mark the matching location for drilling a clearance hole when assembling the extrusion, panel and handle.

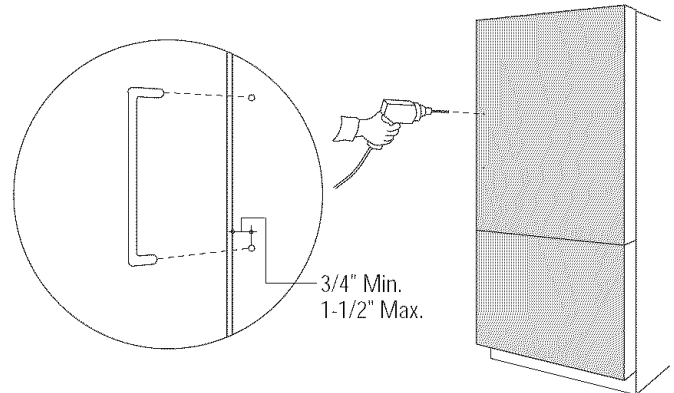

**Freezer Drawer:**

- Follow the same procedures as for the fresh food door.

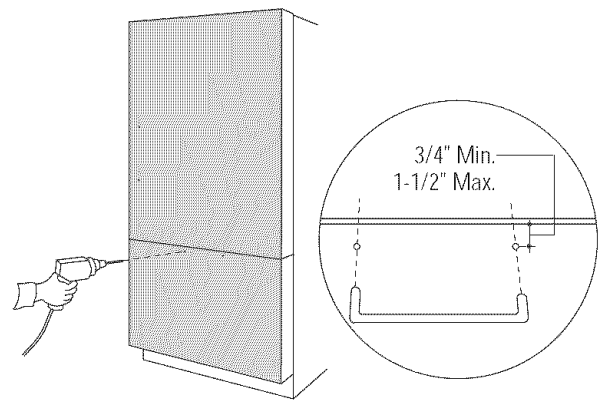

**Step 3**  
**Assemble**  
**panel,**  
**extrusion and**  
**handle**

**Fresh food door:**

- Remove the handle extrusion, the 2 temporary screws and custom panel.
- Drill 1/16" pilot hole through extrusion.
- Drill clearance holes through the panel and extrusion.
- Assemble the panel, extrusion and custom handle.
- Install screw(s) long enough to pass through the extrusion, door panel and into the handle.

**Freezer drawer:**

- Remove the handle extrusion and entire assembled drawer door.
- Remove panel from drawer door.
- Drill clearance holes through the panel and extrusion.
- Assemble the panel, extrusion and custom handle.
- Install screw(s) long enough to pass through the extrusion, door panel and into the handle.

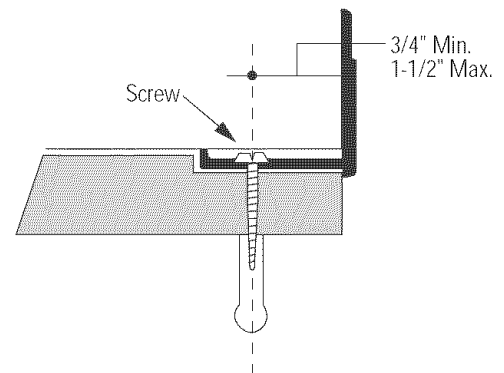

**Step 4**  
**Mount**  
**assembled**  
**panels**

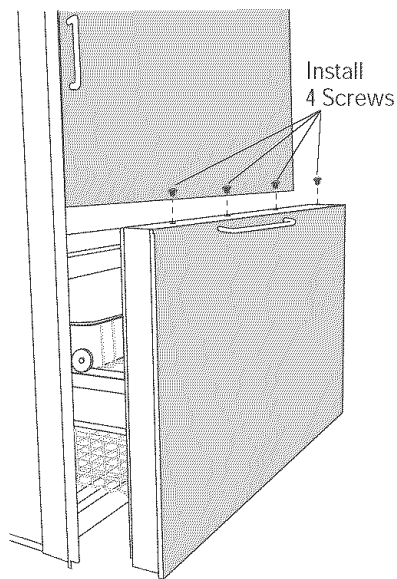
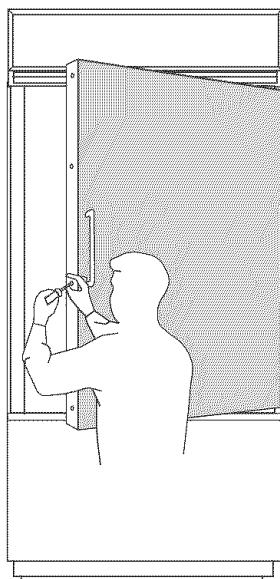

**Fresh food door:**

- Place assembled panel onto the bottom trim with support bracket tabs inserted into slots.
- Push the panel back against the steel door with handle extrusion flush to handle side of the door.
- Open door fully to stop.
- Install original screws at the top, hinge side and handle side.

**Freezer drawer:**

- Mount assembled door with panel onto freezer slides.
- Install original screws along the top handle extrusion.

# ZKHCS1 Trim Kit (For 1/4" Panels)

## Tubular Stainless Steel Handles

Right hand door swing models are illustrated in these instructions. Follow these instructions for left hand models.

**Note:** It is best that 2 people install this kit.

Tools and materials required:

- #2 Phillips screwdriver
- Drill and appropriate bits
- Custom door & drawer panels
- Safety glasses
- Center punch
- Masking tape
- Hammer
- Pencil
- 1/2" thick 12" x 12" min. piece of plywood to protect floor when drilling
- For stainless steel panels, wear gloves to protect against sharp edges.

### Parts List:

- A. Handle extrusion (for left hand models)
- B. Handle extrusion (for right hand models)
- C. Freezer handle extrusion.
- D. Fresh food and freezer door handles
- E. 6 Spacer rings (for Stainless Panels ONLY)  
(4 required, 2 extra)
- F. 4 Handle standoffs
- G. 6 Screws for mounting handle standoffs  
(4 required, 2 extra)
- H. 6 Set screws (4 required, 2 extra)
- I. 3/32" Allen wrench for set screws

This kit provides for the installation of Stainless Steel handles on 1/4" thick decorator door panels. The door extrusions allow these custom handles to be secured to the door structure, rather than to the custom panels.

- Select fresh food extrusion for your model, discard other fresh food extrusion.

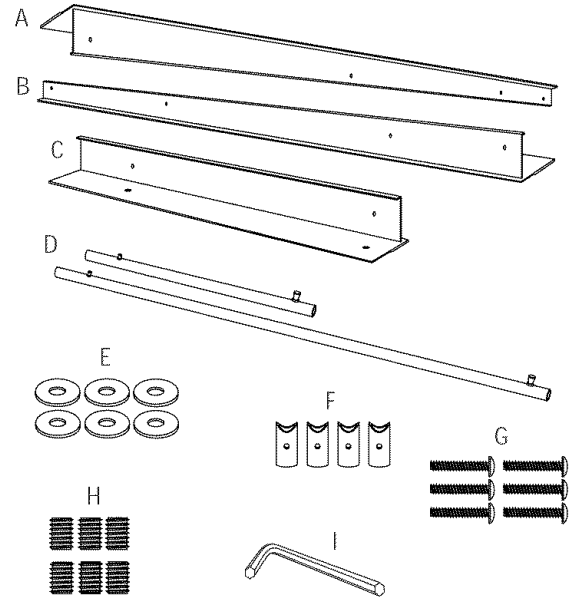

### Step 1 Remove handles

#### Fresh food door:

- Open fresh food door to 90°. Remove the screws from the full-length handle.
- Retain screws, discard handle.

#### Freezer drawer:

- Slide the drawer open about half way.
- Carefully remove the Phillips head screws from the top trim. Lift off handle.
- Retain screws, discard handle.

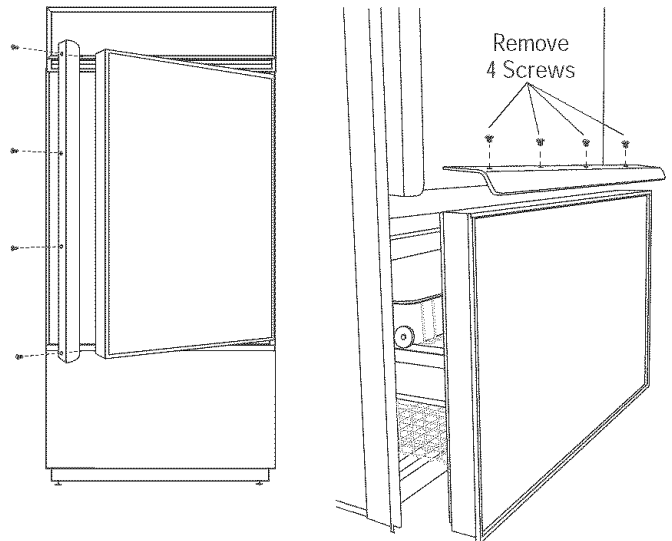



**Step 2**  
**Match**  
**handle**  
**extrusions**  
**to handle**

**FOR CUSTOM**  
**WOOD**  
**PANELS**

**See Step 2A**  
**for Stainless**  
**Steel panels**

- Cut a piece of corrugated to use as a pad to protect the panel finish. Use 1/2" thick section of plywood to protect flooring when drilling.
- Place custom panels on the pad, appearance side down.

**Fresh food door:**

- On the back side of the panel - at the handle side, measure and mark 1/4" below the top edge of the panel with a pencil.
- Slip panels into new extrusion on the handle side of the panels.
- Align the extrusion at the pencil mark, 1/4" below the top of the panel.
- Tape the extrusion to the panel to prevent movement.
- Center punch and drill 1/8" pilot holes through the holes in the extrusion and into the panel.
- Turn panel over. On the appearance side, use 9/32" bit to enlarge clearance hole.

**Freezer drawer:**

- Lay panel on the pad, appearance side down.
- Slip panel into the new extrusion on the handle end.
- The panel should be even with both ends of the extrusion. Tape panel to extrusion to prevent movement.
- Center punch and drill 1/8" pilot holes through the holes in the extrusion and into the panel.
- Turn panel over. On the appearance side, use 9/32" bit to enlarge clearance hole.

**CAUTION:** Hole locations must be exact to accept handle standoff and handle assembly.

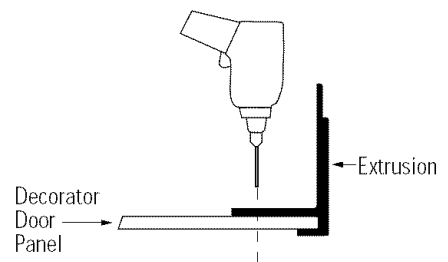
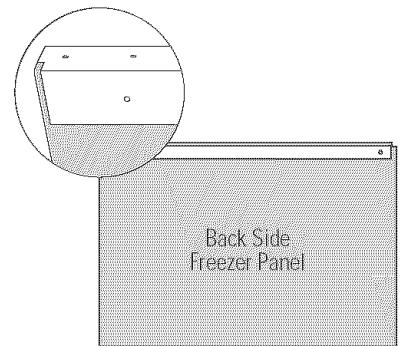
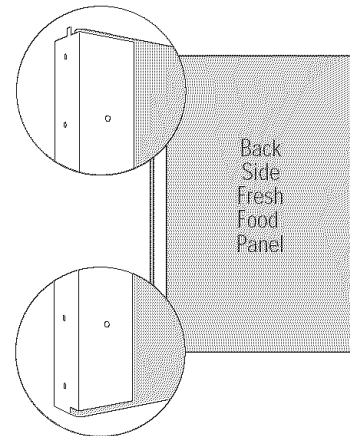

### Step 2A

**FOR  
STAINLESS  
STEEL  
PANELS**

#### If you are installing these handles onto Stainless Steel Panels:

Use extreme caution if you are drilling through stainless steel panels. Stainless steel panels must be handled gently. Do not kneel on stainless steel panels. It will leave a permanent dent. Do not remove protective plastic covering until final installation.

#### Fresh food door:

- Place supplied filler panel (corrugated) on floor to use as a pad.
- On the back side of the panel - at the handle side, measure and mark 1/4" below the top edge of the panel.
- Slip panel into the new extrusion, flush against inner edge, on the handle side.
- Align extrusion to pencil mark as shown in Step 2. Mark each screw hole location with pencil.

- Tape extrusion to panel to prevent movement.
- Place panel on plywood section, appearance side down. Be sure plywood is clean without nicks and burrs. Center punch at each screw hole location.
- Drill 1/8" pilot hole. Use 9/32" bit to enlarge clearance hole.
- Measure and cut a 2" wide strip, top to bottom off the corrugated panels. This will allow room for spacer rings between the stainless panel and extrusion.

#### Freezer drawer:

- Place supplied filler panel (corrugated) on floor to use as a pad.
- On the back side of the panel - at the handle end, slip panel into the new extrusion, even end to end.
- Mark each screw hole location with pencil.
- Follow the same procedure as for fresh food door.

### Step 3 Install standoffs onto handles

- Place a handle standoff onto attachment posts along the handle. Position the set screw hole on the standoff to point to the floor.
- Install set screws into the bottom of each standoff, using the Allen wrench provided. The standoff should be tight against the handle.

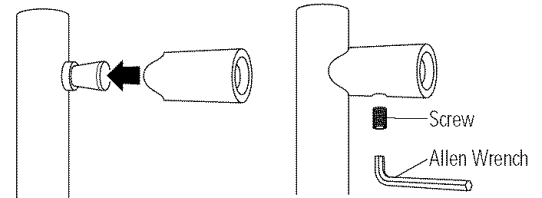

### Step 4 Install handles and panels

**FOR CUSTOM  
WOOD  
PANELS**

**See Step 4A  
for stainless  
steel panels**

#### Fresh food door:

- Slide panel into the door trim. Leave about 4" of the panel exposed to allow room to install the handle extrusion.
- Place extrusion onto the back side of the panel, install mounting screws through the extrusion and just through the panel.
- Drive screw part way through the top standoff, then part way through the bottom standoff.
- Drive both screws until the handle is tight against the panel.
- Remove tape.
- Slide the assembled panel into the door trim until the extrusion fits firmly against the steel door. Reinstall original screws into the extrusion.

#### Freezer drawer:

- Slide panel into the drawer trim. Leave about 4" of the panel exposed to allow room to install the handle extrusion.
- Place extrusion onto the panel, install mounting screws through the extrusion and just through the panel.
- Drive screw part way through one standoff, then part way through the other standoff.
- Drive both screws until the handle is tight against the panel.
- Remove tape.
- Slide the assembled panel down until the extrusion fits firmly against the top of the drawer. Reinstall original screws into the extrusion.

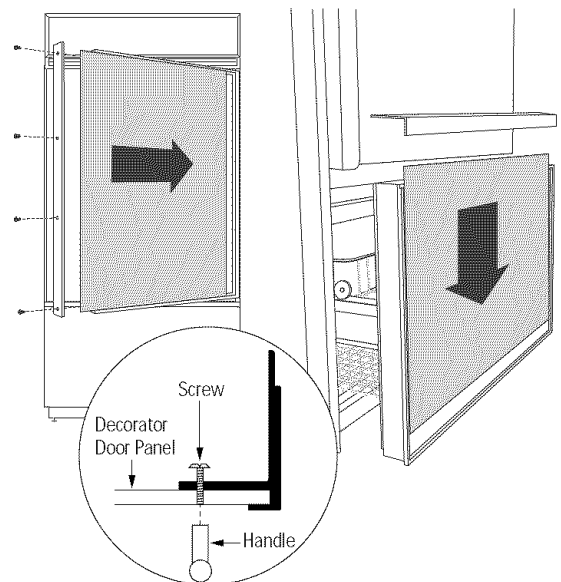

**Step 4A**  
**Install**  
**handles and**  
**panels**

**FOR**  
**STAINLESS**  
**STEEL**  
**PANELS**

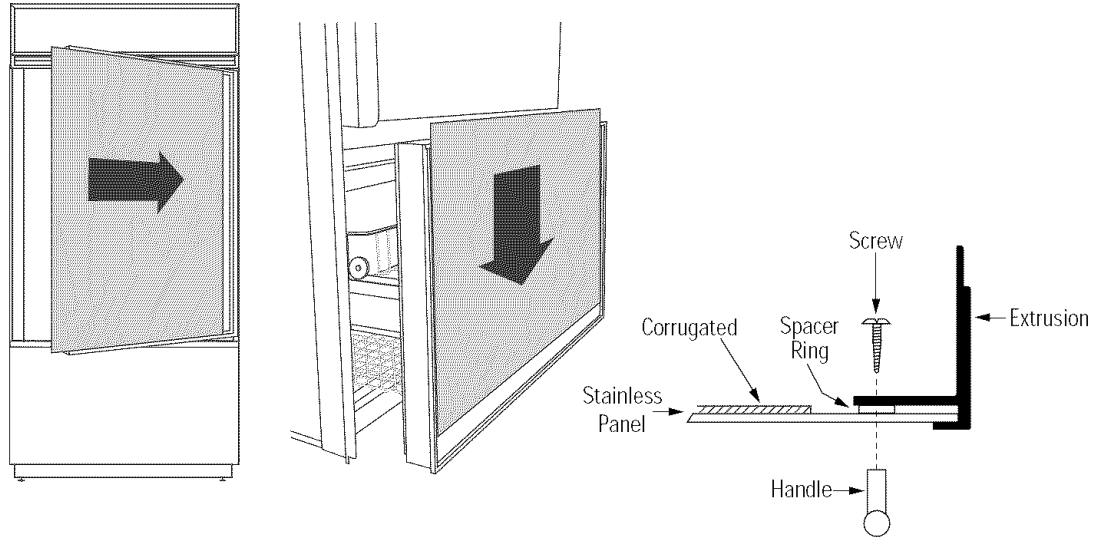

- Crimp top and bottom edges of corrugated.
- Slide corrugated into door and drawer trim. Leave about 1/4" gap between edge of corrugated and hinge side trim of the door and 1/4" gap above bottom trim of the drawer.

**Note:** Panels have a protective plastic covering. Peel away just enough to allow panel to slide into trim and to clear handle mounting screws. The plastic covering will keep the panels clean during the installation process.

Be sure to maintain 1/4" gap between corrugated and hinge side or bottom trim.

**Fresh food door:**

- Slide panels into the door trim. Leave about 4" of the panel exposed to allow room to install the handle extrusion.
- Place a spacer ring over each of the 2 screw holes on the extrusion. Use tape to hold in place.

- Place extrusion onto panel. Use a pencil to punch hole in tape covering spacer rings and align with screw holes.
- Install mounting screws through the extrusion and panel.
- Drive screw part way through the top standoff, then part way through the bottom standoff.
- Drive both screws until the handles are tight against the panel.
- Slide the assembly into the door trim until the extrusion fits firmly against the steel door.
- Reinstall original screws into the door extrusion.

**Freezer drawer:**

- Follow the same procedure to install spacer ring, mounting screws and handle to extrusion as described for fresh food panel.
- Slide the assembly down into the door trim until the extrusion fits firmly against the steel drawer.
- Reinstall original screws into the door extrusion.

**Raised Panel on 1/4" Thick Backing:**

A raised panel design secured to a 1/4" thick backing (screwed or glued) can be used with this handle kit.

- Cut the 1/4" thick panels to size.
- Fabricate the raised panel to allow 1-1/4" clearance from the hinge side of the fresh food panel to avoid striking adjacent cabinetry.
- Allow 5/16" clearance at the other edges to allow for the trim flange.
- Total panel thickness should not exceed 3/4".
- Countertops adjacent to the refrigerator installation should be mitered 45°.

**Note:** Longer Screws, obtained locally, will be required to accommodate panel thickness. Use stainless steel #10-32x1-1/4" truss Phillips head screws.

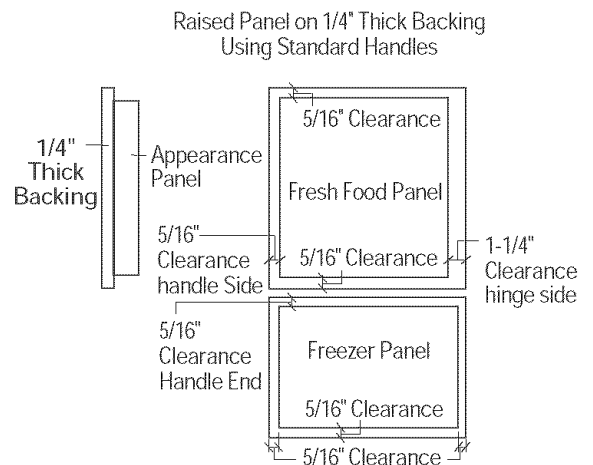

# ZKHTCSS1 for 3/4" panels

## Tubular Stainless Steel Handles

### Kit Contents

Right hand door swing models are illustrated in these instructions. Follow these instructions for left hand models.

This kit provides for the installation of Stainless Steel handles on 3/4" thick decorator door panels. The door extrusions allow these custom handles to be secured to the door structure, rather than to the custom panels.

- Select fresh food extrusion for your model, discard other fresh food extrusion.

### Tools and materials required:

- #2 Phillips screwdriver
- Drill and 1/8", 9/32" bits
- Custom door panels
- Safety glasses
- Center punch
- Masking tape
- Hammer
- Pencil

### Parts List:

- A. Handle extrusion (for left hand models)
- B. Handle extrusion (for right hand models)
- C. Freezer drawer handle extrusion
- D. 2 Stainless tubular handles
- E. 4 Handle standoffs
- F. 6 Screws for handle standoffs (4 required, 2 extra)
- G. 6 Set screws (4 required, 2 extra)
- H. 3/32" Allen wrench for set screws

This kit must be used in combination with ZKTC36, trim kit.

**Note:** It is best that 2 people install this kit.

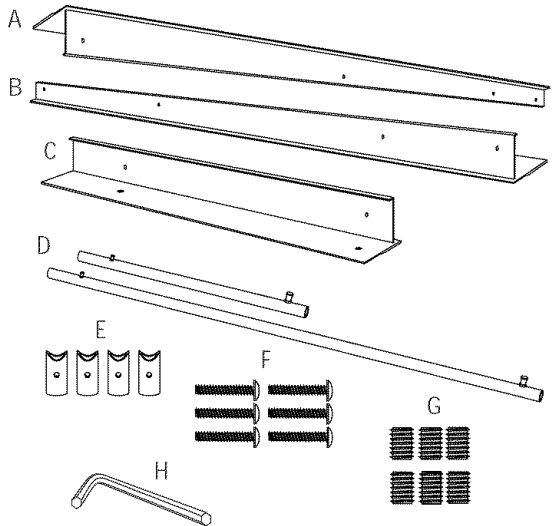

### Before you begin:

- 3/4" custom panels must be routed to accommodate these handle extrusions. Rout the panels as illustrated, 1/4" deep, and 1-13/16" wide, top to bottom on the handle side.
- Follow the instructions in the ZKTC36R (or ZKTC36L) to install trim onto the fresh food and freezer drawer. Discard the handles supplied with that kit.
- Continue the instructions in the ZKTC36R (or ZKTC36L) trim kit to install support brackets to the bottom of the fresh food and freezer panels.

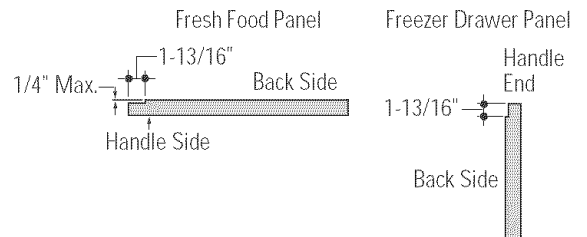

**CAUTION:** Optional final appearance depends on careful routing depth. Do not exceed 1/4" routing depth.

### Step 1 Match Handle Extrusions to Panels

- Cut a piece of corrugated to use as a pad to protect the panel finish. Additional material may be required to protect flooring when drilling.
- Place custom panels on the pad, appearance side down.

**Note:** If panels are wood, be sure to note which end is the top so that wood grain is in the correct direction on both sides.

#### Fresh Food Panel:

Select fresh food handle extrusion for your model, left or right side extrusion.

- Place extrusion against the handle side of the fresh food panel.
- Align the extrusion evenly with the top and bottom of the panel.
- Tape the extrusion to the panel to prevent movement.
- Center punch and drill 1/8" pilot holes through the holes in the extrusion and into the panel.
- Turn panel over. On the appearance side, use 9/32" bit to enlarge clearance hole.

#### Freezer Panel:

- Place extrusion against the handle end of the freezer drawer panel.
- Align the extrusion evenly, side to side.
- Tape the extrusion to the panel to prevent movement.
- Center punch and drill 1/8" pilot holes throughout the holes in the extrusion and into the panel.
- Turn panel over. On the appearance side, use 9/32" bit to enlarge clearance holes.

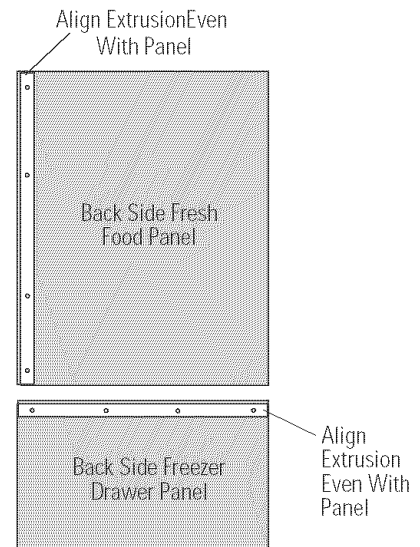

**CAUTION:** Hole locations must be exact to accept handle standoff and handle assembly.

### Step 2 Install Standoffs onto Handles

- Place a handle standoff on each attachment post on the handle. Position the screw hole on the standoff to point to the floor.
- Install set screws into the bottom of each standoff, using the Allen wrench provided. The standoff should be tight against the handle.

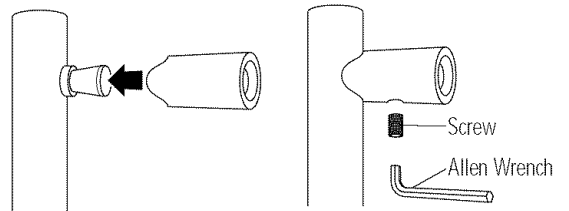

**Step 3  
Install  
mounting  
screws  
and handles**

**Fresh Food Panel:**

- Start mounting screws through the extrusion and just through the custom panel.
- Stand panel up on the hinge side and hold to access the appearance side. Place handle against mounting screws on the appearance side, drive top screw from the back of the extrusion partially into the standoff.
- Drive second screw partially into the standoff, alternate back to the top until the handle is tight against the door.

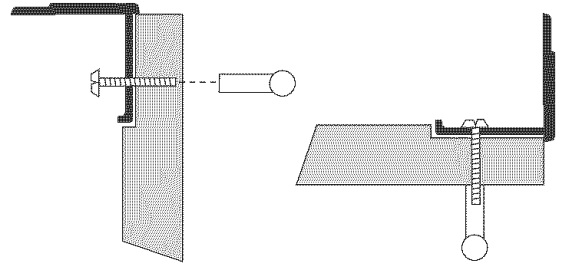

**Freezer Drawer Panel:**

- Follow the same procedure to assemble handle to panel.

**Step 4  
Install  
Assembled  
Panels**

*It is best that 2 people perform this step.*

**Fresh Food Panel:**

- Place assembled panel onto the bottom door trim with support bracket tabs inserted into slots.
- Push and hold the panel back against the steel door with door handle extrusion flush to the handle side of the door.
- Reinstall original screws into the door extrusion.
- Open the door fully to stop.
- Install screws at the top, and hinge side.

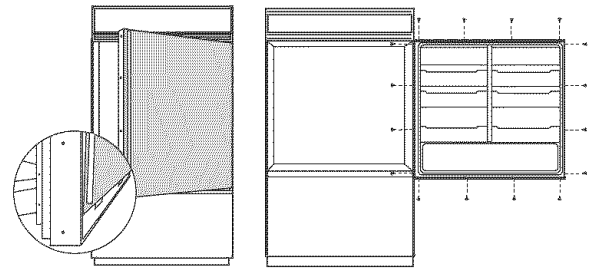

**Note:** The freezer drawer panel should be removed as shown in the installation instructions for the ZKTC36 kit. Follow the instructions in Step 1 to remove the door.

**Freezer Drawer Panel:**

- Place the assembled panel onto the bottom trim with support brackets inserted into slots. The panel should be flush with trim on both sides.
- Secure the panel to the trim at the bottom and both sides.
- Mount the assembled drawer panel onto the freezer slides. Tighten all screws.
- Install 4 screws into the top of the handle extrusion and into the door.

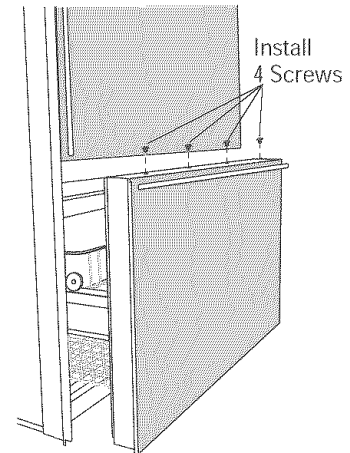

# ZFC1 Trim Kit

## Side to Side Installation

For the ultimate in convenience, install two refrigerators side to side.

This trim kit includes 6 foam spacer pads to fill the gap between the refrigerator side case trims. For a finished appearance, a trim strip is provided to conceal the case trim of the two refrigerators.

If you are installing into an enclosure, provide a 72" wide opening. If you are installing where the sides of the refrigerators will be exposed, allow additional width for any side panels used.

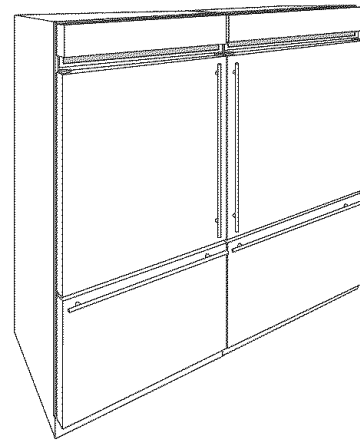

- Apply foam spacer pads evenly to the side of one refrigerator as shown.
- Slide second refrigerator into position.
- Check to be sure both refrigerators are level. If they are not level, an obvious gap can be seen between the side trims. Adjust leveling legs if needed. Slight gaps will be concealed with the trim strip.
- Open both fresh food doors to access side trim.
- The U-shape trim will overlap the side case trim of both refrigerators.
- Set the top case trim (see page 17) to installation height.
- Hold trim strip against top end of case, at the point where case overlaps to the bottom of case trim. See illustration.
- Mark length with a pencil.
- Trim excess length.
- Starting at the top, press trim strip over case trims of both refrigerators.
- Continue pressing about half way down. Slide open freezer drawers and continue pressing trim until you reach the bottom of the strip.

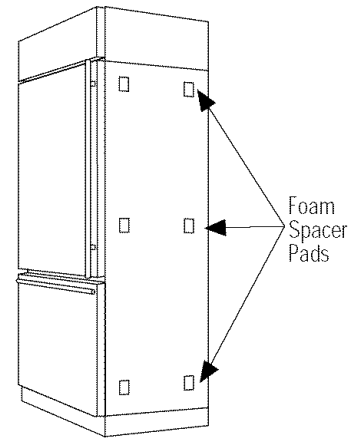

Case Trim

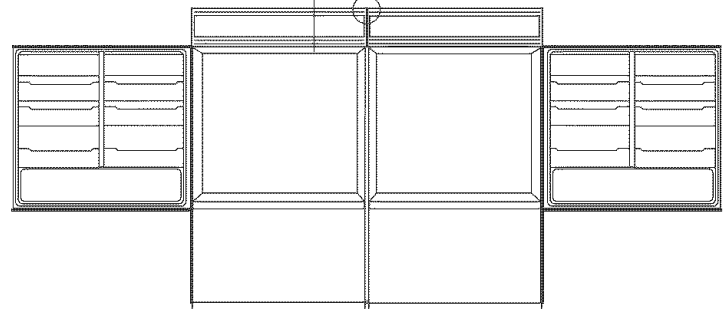
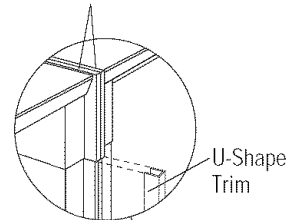

**Note:** While performing installations described in this book, safety glasses or goggles should be worn.

*To obtain specific information concerning any Monogram product or service, call GE Answer Center<sup>®</sup> consumer information service at 800.626.2000—any time, day or night.*

*For Monogram<sup>™</sup> local service in your area, call 1-800-444-1845.*

**Note:** Product improvement is a continuing endeavor at General Electric. Therefore, materials, appearance and specifications are subject to change without notice.



**Monogram.<sup>®</sup>**

General Electric Company  
Louisville, KY 40225

Pub. No. 49-600000  
1998 GE Appliances  
Printed in U.S.A. (ND 978A) 8/98  
5A 95020-00