

Model No. 831.153992

Serial No. _____

Write the serial number in the space above for future reference.

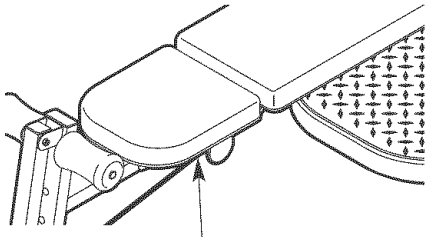

Serial Number Decal (under seat)

- Assembly
- Adjustments
- Part List and Drawing



Visit our website at

www.weiderplatinum.com

CAUTION

Read all precautions and instructions in this manual before using this equipment. Save this manual for future reference.

W E I D E R[®]

PLATINUM XP600

RESISTANCE SYSTEM EXERCISER User's Manual

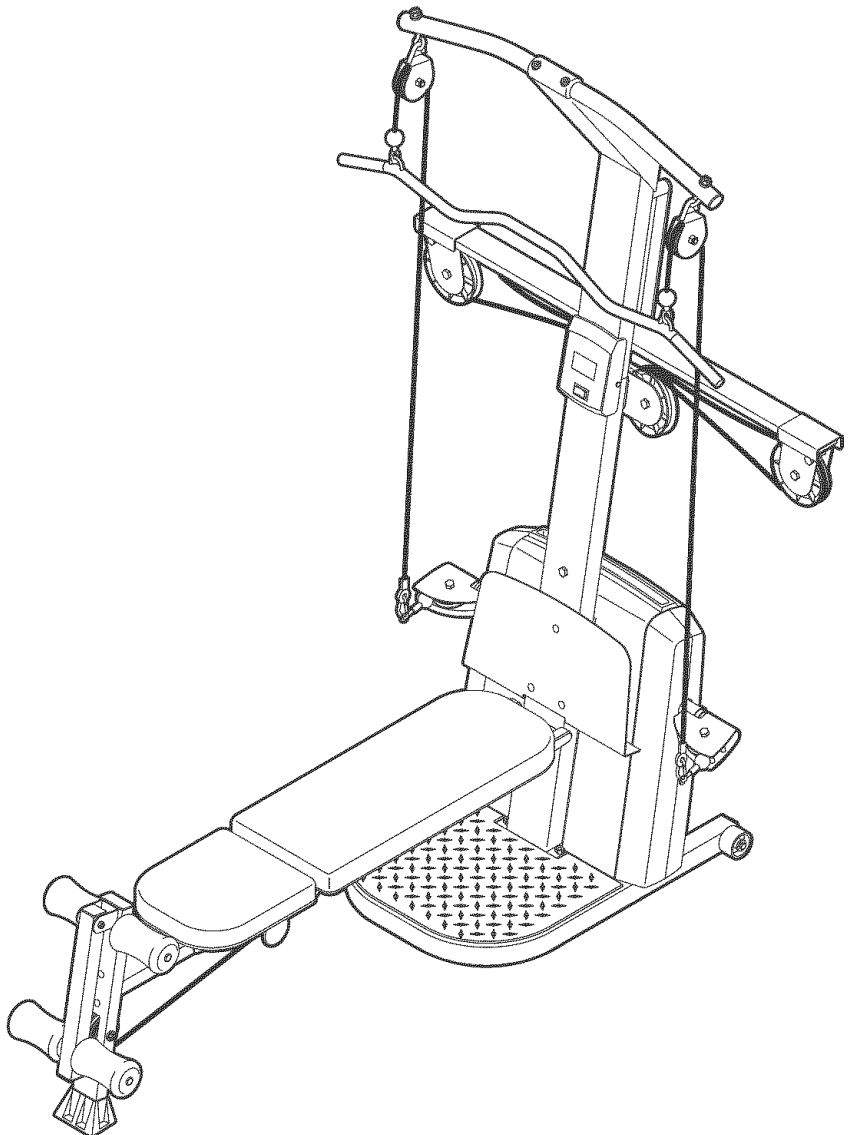

Sears, Roebuck and Co., Hoffman Estates, IL 60179

TABLE OF CONTENTS

WARNING DECAL PLACEMENT	3
IMPORTANT PRECAUTIONS	4
BEFORE YOU BEGIN	5
ASSEMBLY	6
UPPER CABLE ADJUSTMENT	14
ADJUSTMENTS	15
CABLE DIAGRAM	18
TROUBLESHOOTING	19
EXERCISE GUIDELINES	20
ORDERING REPLACEMENT PARTS	Back Cover
FULL ONE-YEAR WARRANTY	Back Cover

Note: A PART IDENTIFICATION CHART and a PART LIST/EXPLODED DRAWING are attached in the center of this manual. Remove the PART IDENTIFICATION CHART and PART LIST/EXPLODED DRAWING before beginning assembly.

WARNING DECAL PLACEMENT

The decals shown here have been placed on the resistance system. If a decal is missing or illegible, please call 1-877-992-5999 to order a free replacement decal. Apply the decal in the location shown.

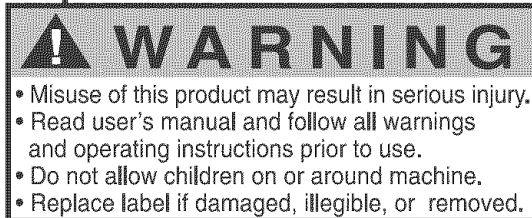
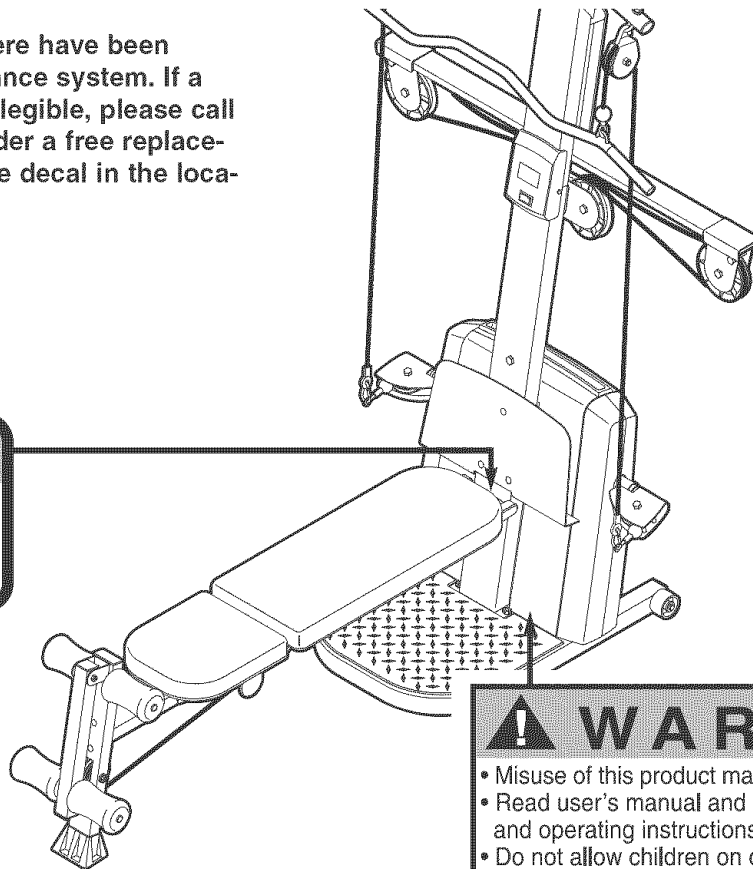

IMPORTANT PRECAUTIONS

⚠ WARNING: To reduce the risk of serious injury, read the following important precautions before using the resistance system.

1. Read all instructions in this manual before using the resistance system. Use the resistance system only as described in this manual.
2. It is the responsibility of the owner to ensure that all users of the resistance system are adequately informed of all precautions.
3. The resistance system is intended for home use only. Do not use the resistance system in any commercial, rental, or institutional setting.
4. Use the resistance system only on a level surface. Cover the floor beneath the resistance system to protect the floor.
5. Make sure that all parts are properly tightened each time the resistance system is used. Replace any worn parts immediately.
6. Keep children under 12 and pets away from the resistance system at all times.
7. Keep hands and feet away from moving parts.
8. Always wear athletic shoes for foot protection while exercising.
9. The resistance system is designed to support a maximum user weight of 300 pounds.
10. Pull on the lower cable only while sitting on the bench or standing on the base plate. Pull on the high cables only while sitting on the bench, with the seat in one of the three positions closest to the upright base, or while standing on the base plate.
11. The crossbar on the top frame is not designed to be used for pull-up exercises. Do not hang on the crossbar.
12. The resistance system is designed to be used with the included resistance. Do not use the resistance system with any other type of resistance.
13. Always disconnect the lat bar from the high cables when performing an exercise that does not require it.
14. Make sure the storage knob is in place and fully tightened each time the resistance system is used.
15. Make sure that the cables remain on the pulleys at all times. If the cables bind as you are exercising, stop immediately and make sure that the cables are on the pulleys.
16. Do not pull on the cables while the resistance level is being adjusted.
17. If you feel pain or dizziness while exercising, stop immediately and begin cooling down.

⚠ WARNING: Before beginning this or any exercise program, consult your physician. This is especially important for persons over the age of 35 or persons with pre-existing health problems. Read all instructions before using. Sears assumes no responsibility for personal injury or property damage sustained by or through the use of this product.

BEFORE YOU BEGIN

Thank you for selecting the innovative WEIDER® PLATINUM XP600 resistance system. The resistance system offers a selection of stations designed to develop every major muscle group of the body. Whether your goal is to tone your body, build dramatic muscle size and strength, or improve your cardiovascular system, the resistance system will help you to achieve the specific results you want.

For your benefit, read this manual carefully before using the resistance system. If you have questions

after reading this manual, call 1-800-4-MY-HOME® (1-800-469-4663). To help us assist you, please note the product model number and serial number before calling. The model number is 831.153992. The serial number can be found on a decal attached to the resistance system (see the front cover of this manual).

Before reading further, please review the drawing below and familiarize yourself with the parts that are labeled.

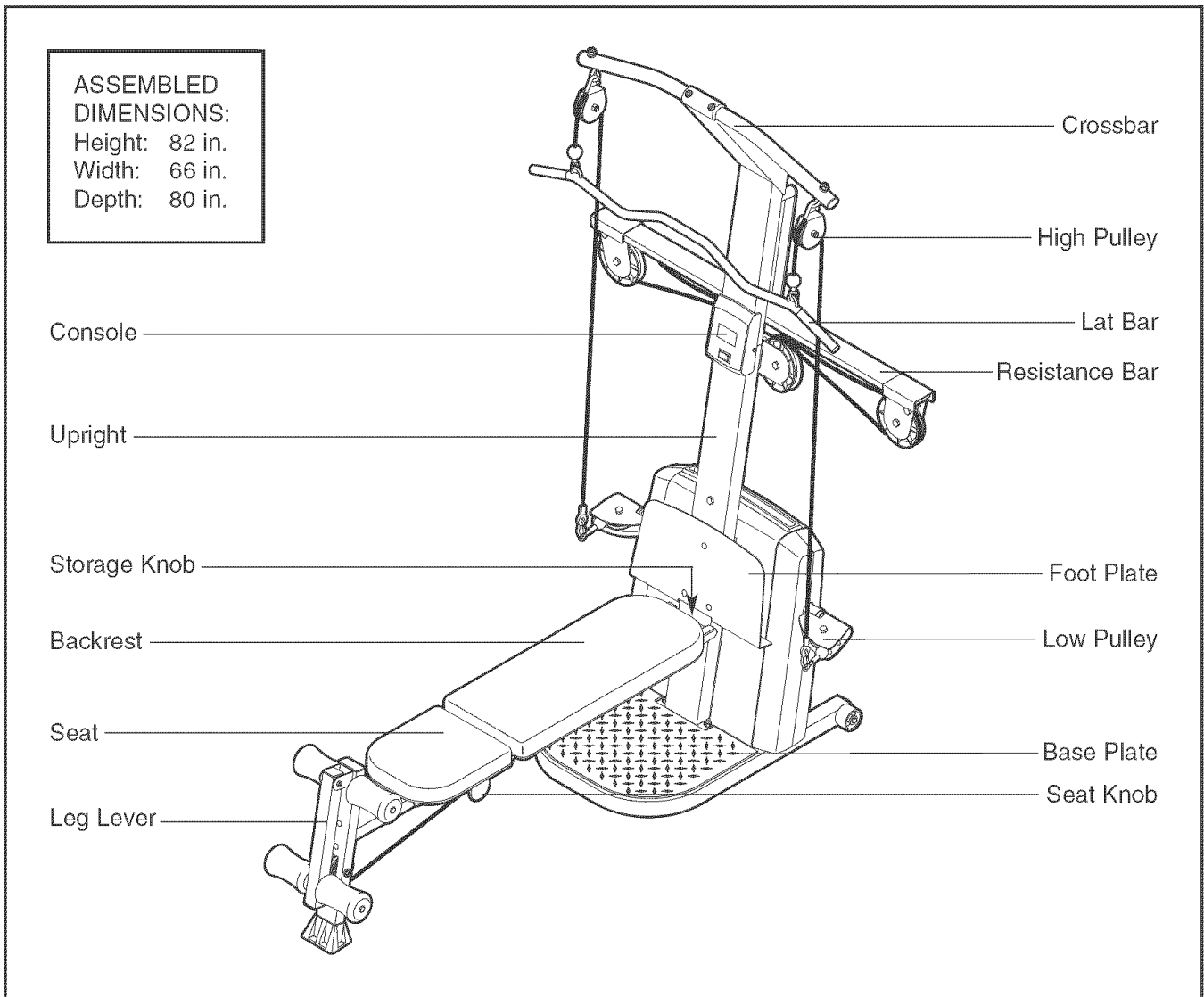

ASSEMBLY

Make Things Easier for Yourself





This manual is designed to ensure that the resistance system can be assembled successfully by most people. However, it is important to realize that the versatile resistance system has many parts and that the assembly process will take time. Most people find that by setting aside plenty of time, assembly will go smoothly.

Before beginning assembly, carefully read the following information and instructions:

- Assembly requires two persons.
- Place all parts in a cleared area and remove the packing materials. Do not dispose of the packing materials until assembly is completed.
- **For help identifying small parts, use the PART IDENTIFICATION CHART.** Note: Some small parts may have been pre-attached for shipping. If a part is not in the parts bag, check to see if it has been pre-attached.

- Tighten all parts as you assemble them, unless instructed to do otherwise.
- As you assemble the resistance system, make sure all parts are oriented as shown in the drawings.

The included Allen wrenches  and the following tools (not included) are required for assembly:

- Two adjustable wrenches 
- One rubber mallet 
- One standard screwdriver 
- One Phillips screwdriver 
- Lubricant, such as grease or petroleum jelly, and soapy water.

Assembly will be more convenient if you have a socket set, a set of open-end or closed-end wrenches, or a set of ratchet wrenches.

1. Before beginning assembly, make sure that you have read and understand the information in the box above.

Attach a Wheel (21) to the Base (1) with an M10 x 108mm Button Bolt (90), three M10 Washers (73), and an M10 Nylon Locknut (71). **Do not overtighten the Locknut; the Wheel must be able to turn easily.**

Attach the other Wheel (21) to the Base (1) in the same manner.

Attach two Plastic Feet (19) and two Large Plastic Feet (20) to the Base (1) with four M4 x 16mm Screws (103).

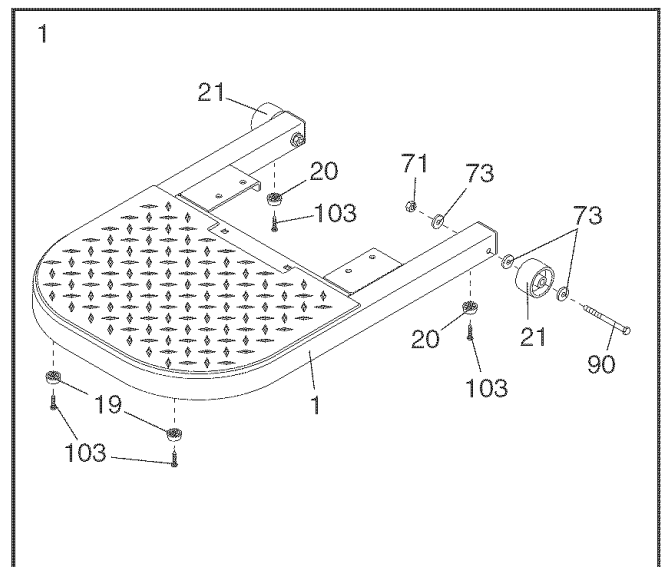

2. Attach the Upright (3) to the Base (1) with two M10 x 66mm Carriage Bolts (89), two M10 x 72mm Bolts (87), and four M10 Nylon Locknuts (71) as shown. **Note: This step will be easier to complete if the Upright and Base are tipped on their sides.**

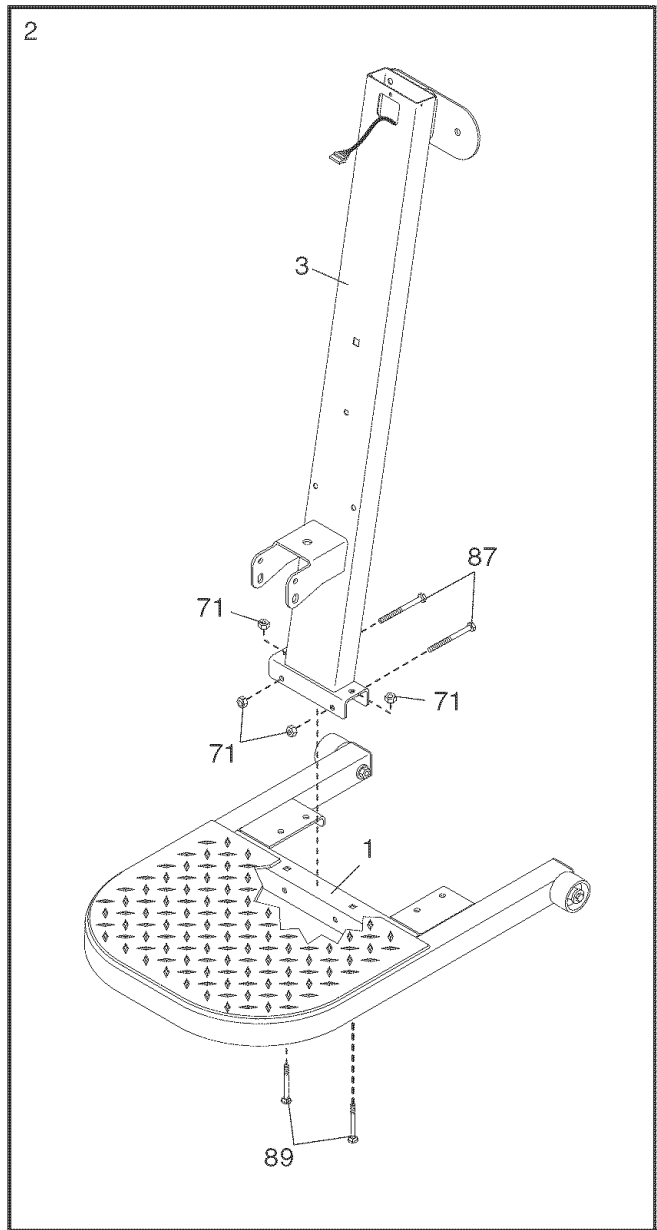

3. Attach the Foot Plate (4) to the Upright (3) with three M10 x 70mm Carriage Bolts (88), three M10 Washers (73), and three M10 Nylon Locknuts (71).

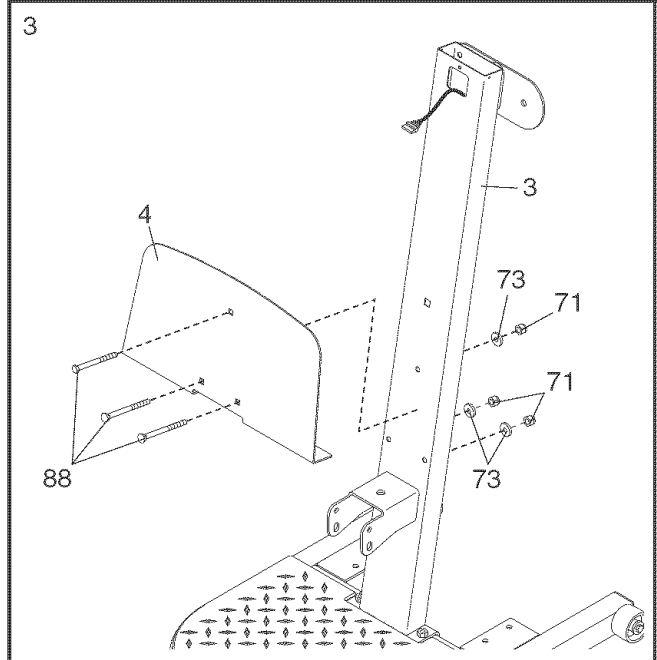

- Insert the connector of the lower wire harness (A) into the socket of the Upper Wire Harness (13). **The connector should slide easily into the socket and snap into place.** If the connector does not slide easily and snap into place, turn the connector over and then insert it.

Make sure that the connector and wire appear as shown in the inset drawing. **IF THE CONNECTOR IS NOT INSERTED PROPERLY, THE CONSOLE MAY BE DAMAGED WHEN THE POWER IS TURNED ON.**

Pull the excess lower wire harness (A) out of the Mech Assembly (6) and push it and the Upper Wire Harness (13) into the Upright (3).

Insert the Mech Assembly (6) into the Base (1). Attach the Mech Assembly to the Upright (3) with a 1/2" x 66mm Carriage Bolt (79) and a 1/2" Nylon Jamnut (78). **Do not tighten the Locknut yet.**

Attach the Mech Assembly (6) to the Base (1) with four M10 Nylon Locknuts (71).

Tighten the 1/2" Nylon Jamnut (78).

- Press the Front Leg Foot (29) onto the bottom of the Front Leg (31). **Note that the front of the Front Leg Foot is taller than the back.**

Attach the Bench Rail (23), with the hook on the bottom, to the Front Leg (31) with two M10 x 53mm Carriage Bolts (91) and two M10 Nylon Locknuts (71).

- Grease an M10 x 103mm Bolt (86) using the included grease pack. Attach the Bench Rail (23) to the Upright (3) with the Bolt and an M10 Nylon Locknut (71). **Make sure the Bolt is inserted through the indicated hole in the Bench Rail. Do not overtighten the Locknut; the Bench Rail must be able to pivot easily.**

Tighten the Storage Knob (26) into the Upright (3) and the Bench Rail (23).

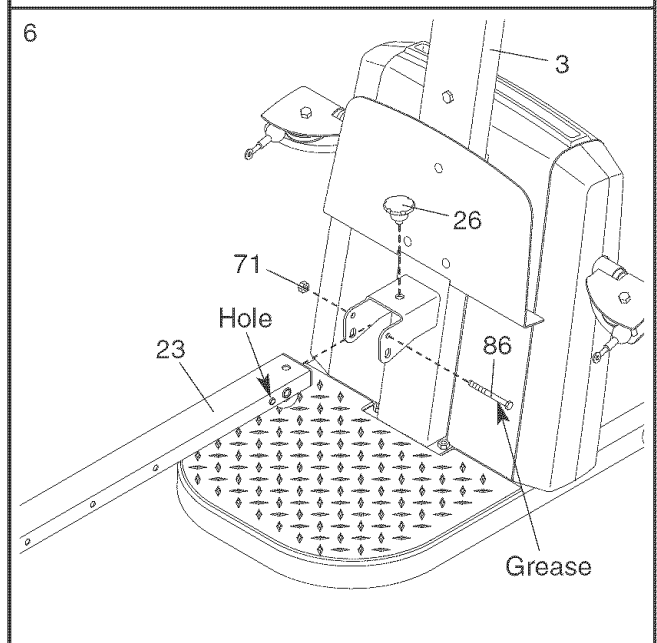
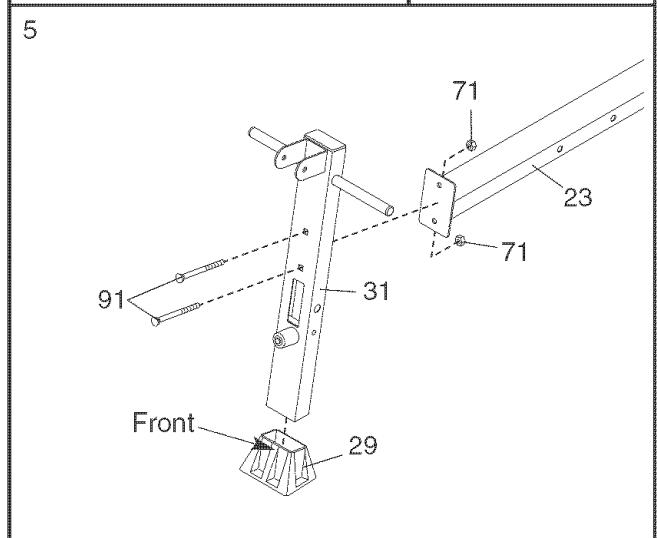
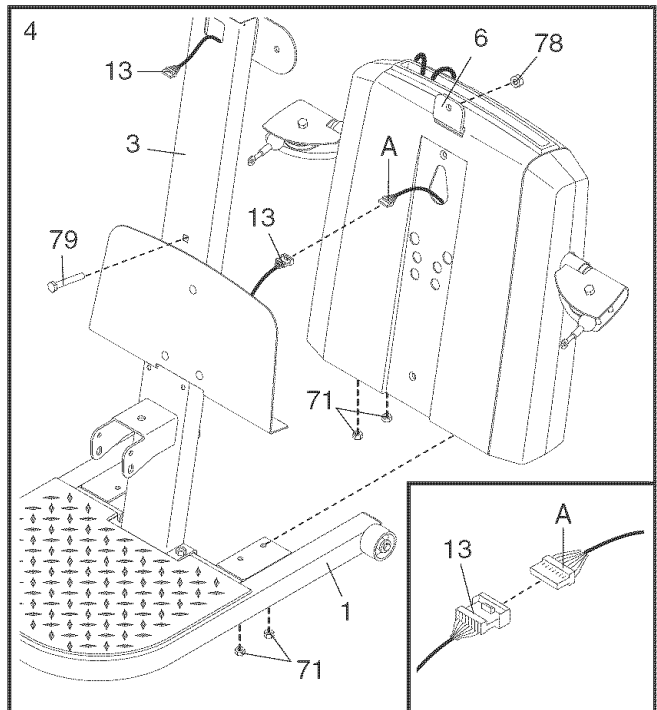

- Grease an M10 x 69mm Bolt (93). Orient the Leg Lever (32) with the slot on the side shown. Attach the Leg Lever to the Front Leg (31) with the Bolt and an M10 Nylon Locknut (71). **Do not over-tighten the Locknut; the Leg Lever must be able to pivot easily.**

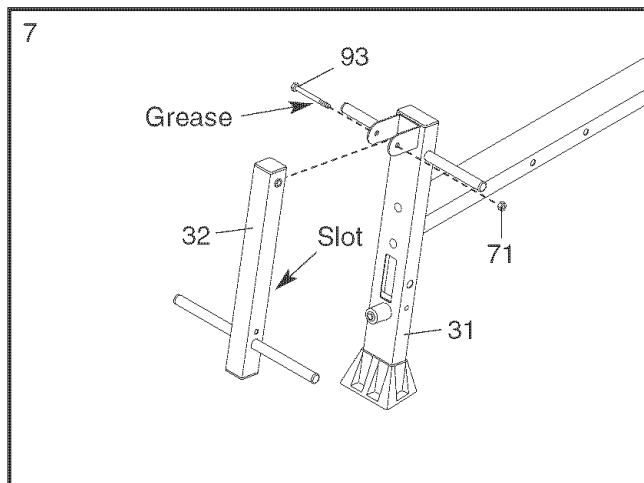

- Attach the Seat Knob (43) to the Seat Carriage (48) with two M6 x 13mm Bolts (105) and two M6 Nylon Locknuts (69). **Make sure that the slot in the Knob is aligned with the slot in the Seat Carriage, as shown.**

Orient the Seat (41), the Seat Backing (42), and the Seat Carriage (48) as shown. Attach the Seat and the Seat Backing to the Seat Carriage with four M6 x 16mm Screws (11).

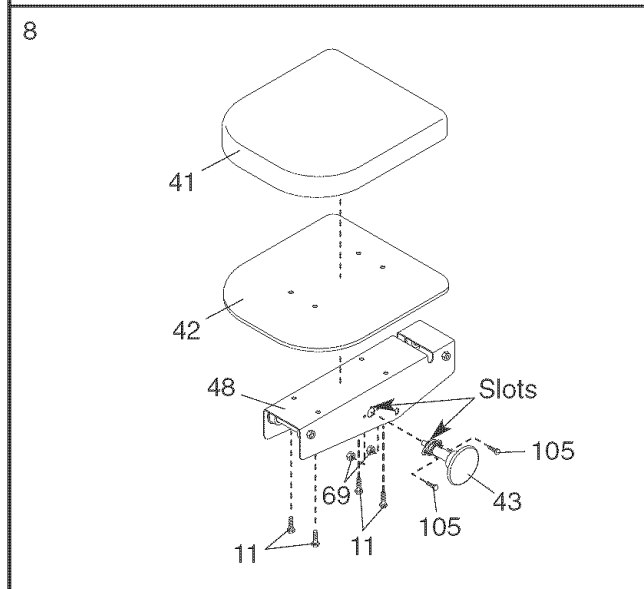

- Pull out the Seat Knob (43) as far as it will go, and set the Seat Carriage (48) on the Bench Rail (23).

Loosely attach two 8mm Metal Spacers (45), a 60mm Metal Spacer (44), and two Bearing Wheels (46) to the center holes in the Seat Carriage (48) with two M8 Flange Nuts (47) and the M8 x 114mm Axle (102). **Make sure that the serrated edge of the Flange Nuts are against the Seat Carriage.**

While a second person presses down on the Seat (41), hold the wheel assembly firmly against the bottom of the Bench Rail (23) and properly tighten the M8 Flange Nuts (47). **Make sure that three threads are extending past the Nuts, and that the wide sides of all six Bearing Wheels (46) are pressed against the Bench Rail.**

Engage the Seat Knob (43) into an adjustment hole in the Bench Rail (23).

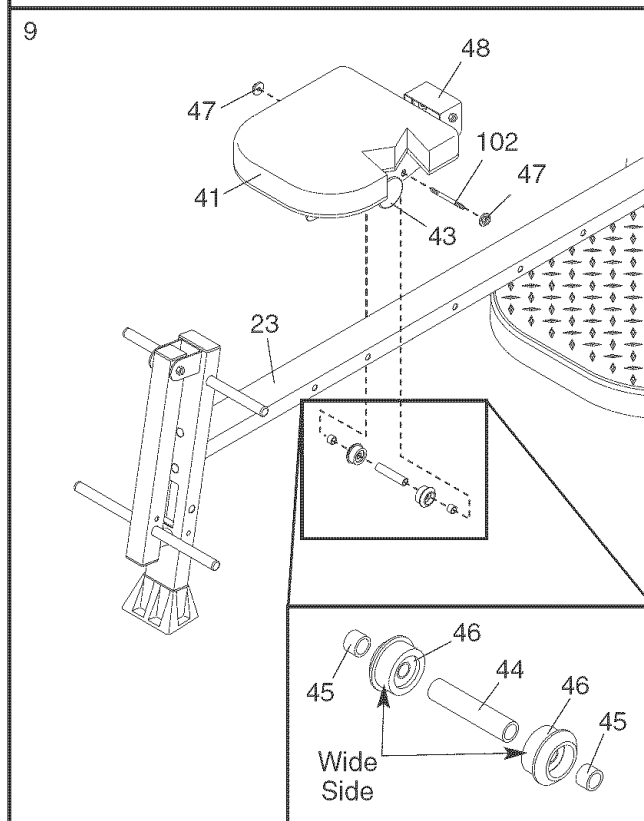

10. Attach the Lat Tower (5) to the Upright (3) with four M10 x 25mm Screws (100) and four M10 Lock Washers (74).

Plug the Upper Wire Harness (13) into the Console (53). **Push all of the excess wire into the Upright (3). Make sure the wire does not get pinched.** Attach the Console to the Upright with two M4 x 16mm Screws (103).

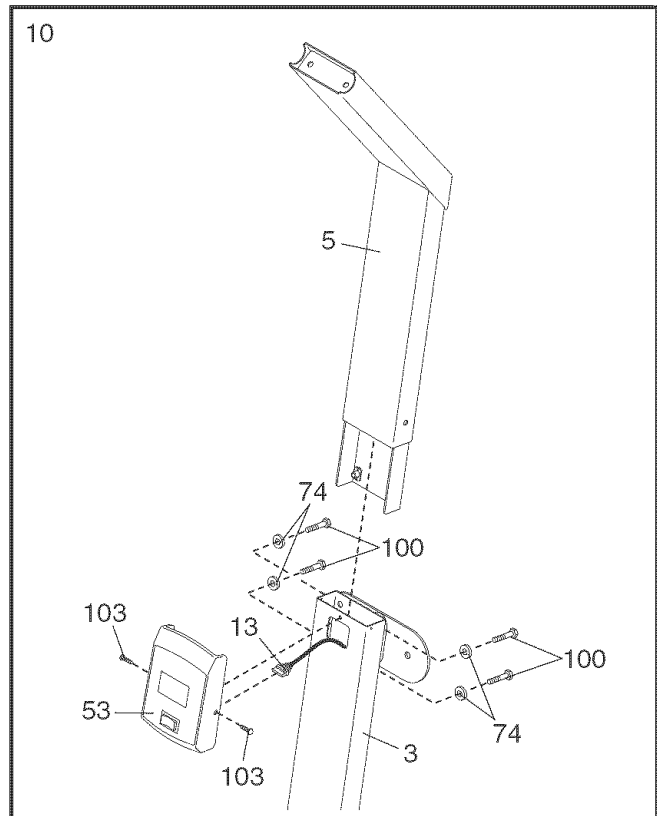

11. Attach two Eyebolts (51) to the Lat Tower Crossbar (49) with two M8 Washers (76) and two M8 Nylon Locknuts (70).

Attach the Lat Tower Crossbar (49) to the Lat Tower (5) with two M10 x 65mm Button Bolts (96), two M10 Washers (73), and the Crossbar Cover (50). **Make sure that the Eyebolts (51) are oriented as shown in the inset drawing. If they are not, turn the Lat Tower Crossbar around and reattach it.**

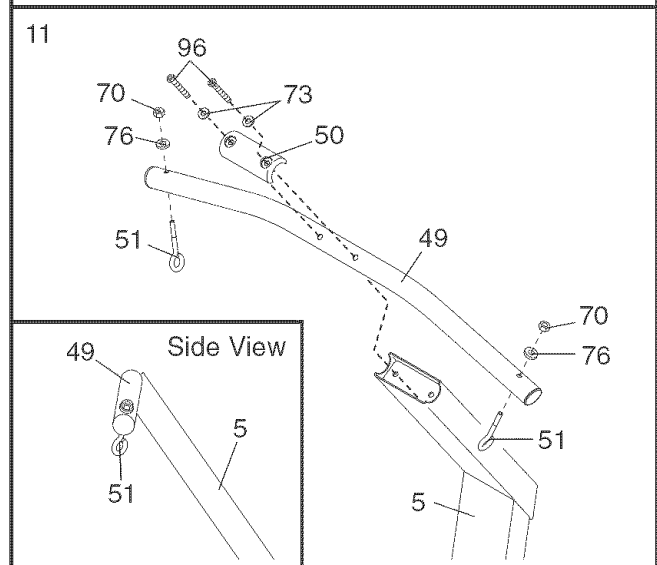

12. Attach a Large Pulley (17) and the Pulley Plate (18) to the Upright (3) with an M12 x 62mm Button Bolt (80) and an M12 Nylon Locknut (72). **Do not tighten the Locknut yet.**

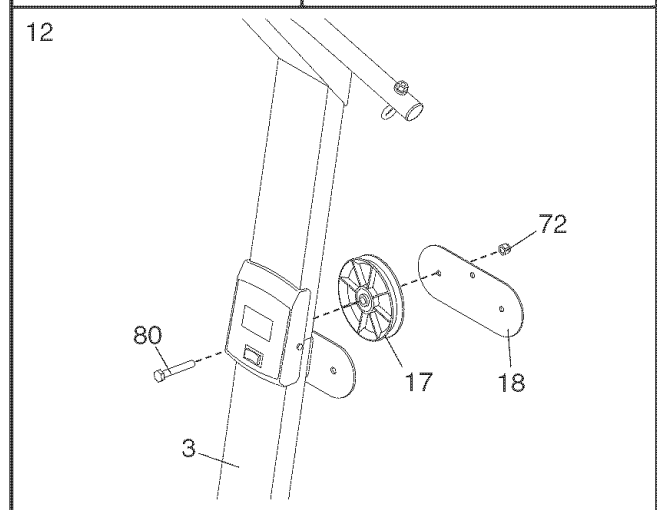

- Pull the upper cable (B), which is attached inside of the Mech Assembly (6), up between the Upright (3) and the Pulley Plate (18).

Attach another Large Pulley (17) between the Upright (3) and Pulley Plate (18) with an M12 x 62mm Button Bolt (80) and an M12 Nylon Locknut (72). **Make sure that the upper cable (B) is between the two Pulleys.**

Hold the 38mm Spacer (54) inside the loop of the upper cable (B), and between the Upright (3) and the Pulley Plate (18). Attach the Spacer with an M10 x 58mm Button Screw (85). **Make sure the ends of the cable do not wrap around each other below the Spacer and the Large Pulleys (17) used in steps 12 and 13 (refer to the CABLE DIAGRAM on page 18).**

Tighten the M12 Nylon Locknuts (72) used in steps 12 and 13.

- Attach a Small Guide Spacer (56), a Large Guide Spacer (57), and two Bar Guides (55) to the Lat Tower (5) with an M10 x 152mm Bolt (83). **Do not tighten the Bolt yet.**

Pull the upper cable (B) up between the Bar Guides (55). Press the metal cover on the cable into the groove in the Block Spacer (58). Attach a Small Guide Spacer (56), the Block Spacer, the two Bar Guides, an M10 Thick Washer (75), and the two Tethers (61) to the Lat Tower (5) with another M10 x 152mm Bolt (83). **Do not tighten the Bolt yet.**

- Insert the Resistance Bar (9) between the Bar Guides (55), and center it on the Block Spacer (not shown).

Press a Pulley Bracket (10) onto the Resistance Bar (9). Attach a Tether (61) to the Pulley Bracket at the upper hole, with an M10 x 63mm Button Bolt (82), an M10 Thick Washer (75), and an M10 Nylon Locknut (71).

Repeat on the other side of the Resistance Bar (9). Then, tighten the M10 x 152mm Bolts (83) used in step 14.

- Hold a Large Pulley (17) inside the upper cable (B). Attach the Pulley to a Pulley Bracket (10) with an M12 x 58mm Button Bolt (81) and an M12 Nylon Locknut (72). **Make sure that the cable is routed as shown in the CABLE DIAGRAM on page 18.**

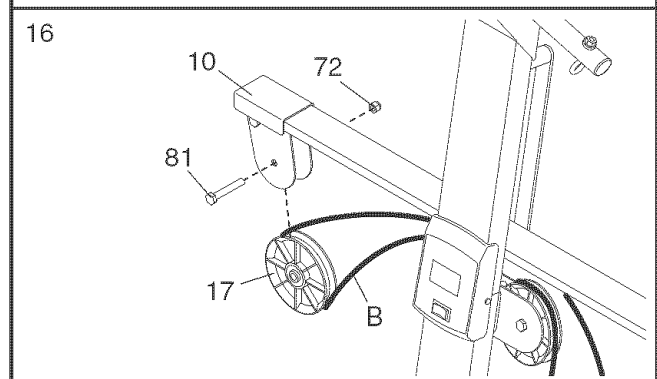
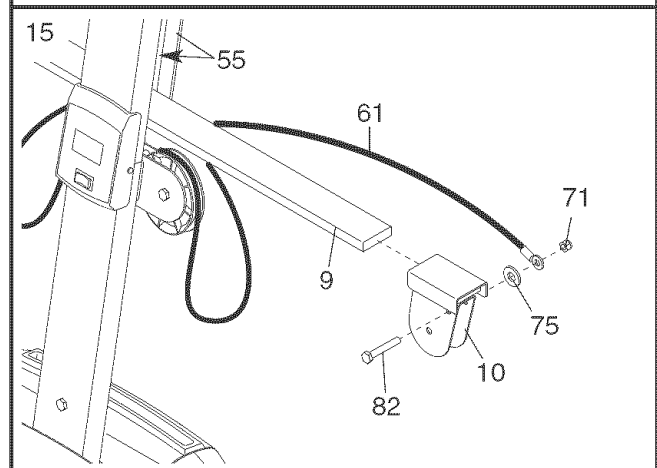
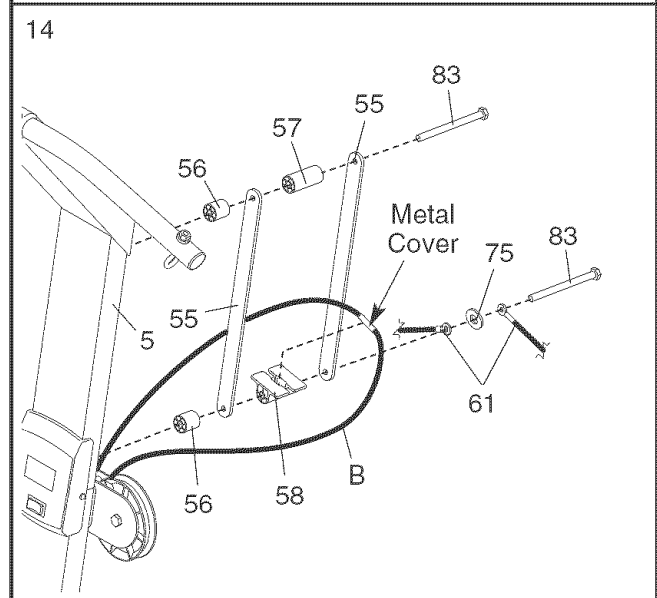
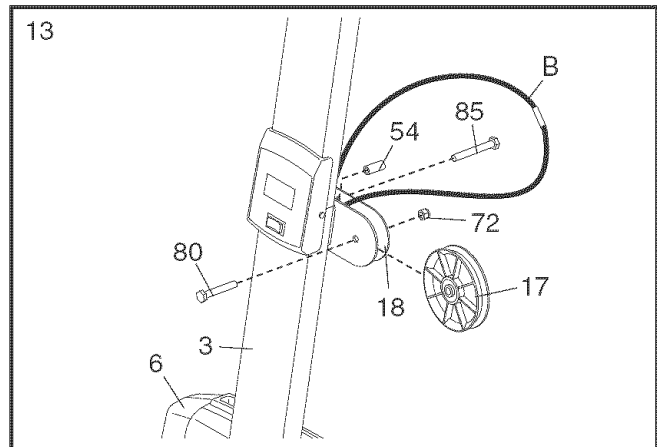

17. Hold a Large Pulley (17) inside the upper cable (B). Attach the Pulley to a Pulley Bracket (10) with an M12 x 58mm Button Bolt (81) and an M12 Nylon Locknut (72). **Make sure that the cable is routed as shown in the CABLE DIAGRAM on page 18.**

Screw two 3/8" x 38mm Tension Screws (108) into the two Pulley Brackets (10) a couple of turns. **Make sure the hexagonal holes in the Screws are on the outside of the Brackets. Tighten the two Screws an equal number of turns.**

18. Attach the Backrest (40) and the Backrest Backing (39) to the Backrest Frame (36) with four M6 x 45mm Screws (98).

19. Attach the two Guard Plates (63) to the inside of the Backrest Frame (36) with four M4 x 16mm Screws (103).

20. Insert the rod on the Backrest Frame (36) into the slot in the Seat Carriage (48). **Hold the Backrest Frame vertically over the Seat Carriage and slide the rod into the slot, as shown in the inset drawing.**

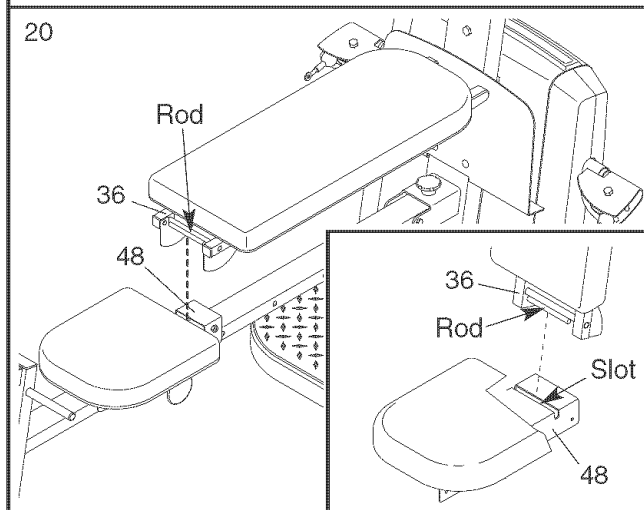
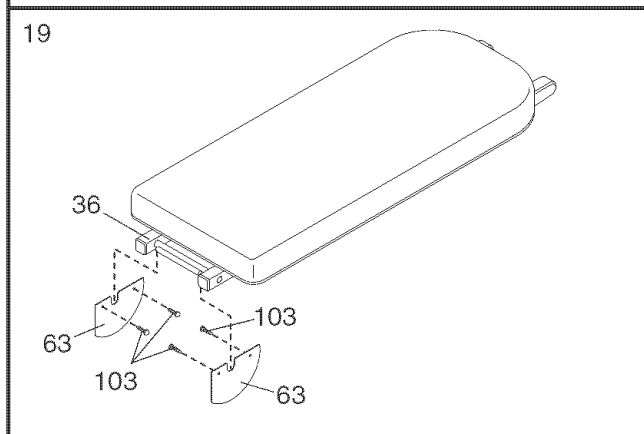
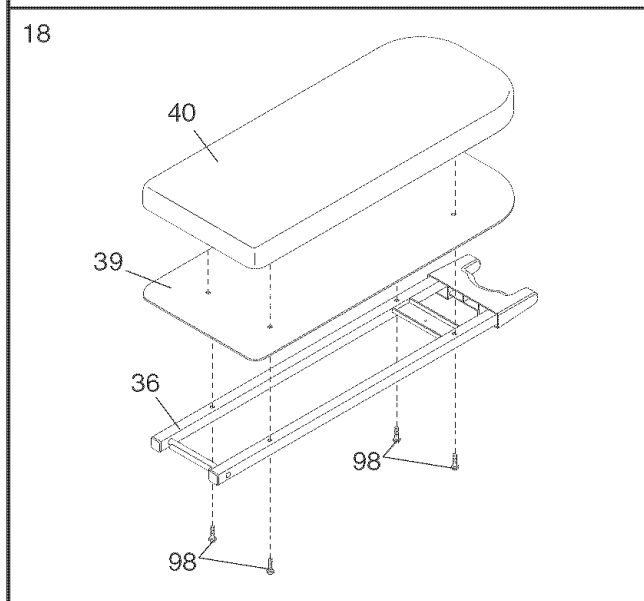
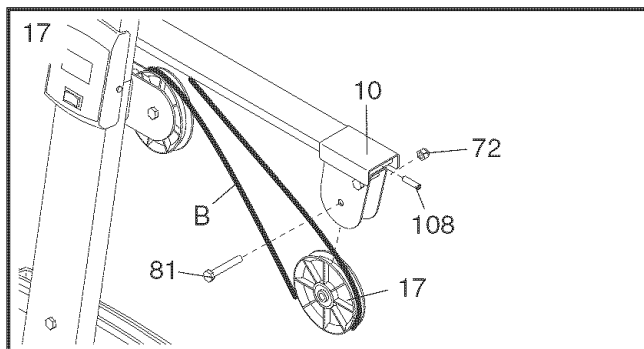

21. **Locate the Leg Lever Cable (62)**, which has two ends that are the same length and a third end that is longer.

Route the longest end of the Leg Lever Cable (62) through the hole in the Front Leg (31), and attach it inside of the slot in the Leg Lever (32) with an M10 x 58mm Bolt (94) and an M10 Nylon Locknut (71).

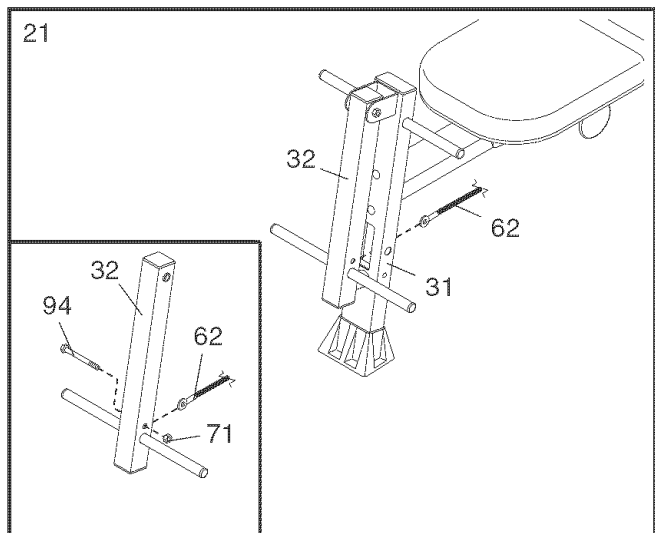

22. Attach a Small Pulley (16) inside of the hole in the Front Leg (31) with an M10 x 91mm Bolt (92), two 26mm Spacers (35), two M10 Washers (73), and an M10 Nylon Locknut (71). **Make sure the Pulley is above the Leg Lever Cable (62).**

Slide the two free ends of the Leg Lever Cable (62) onto the hook welded to the bottom of the Bench Rail (23).

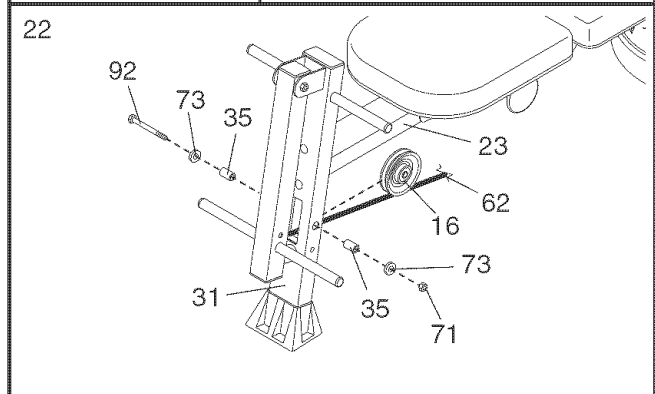

23. Slide two Foam Pads (28) onto the tube on the Front Leg (31). Press two 19mm Round Inner Caps (33) into the ends of the tube.

Repeat this step with the Leg Lever (32).

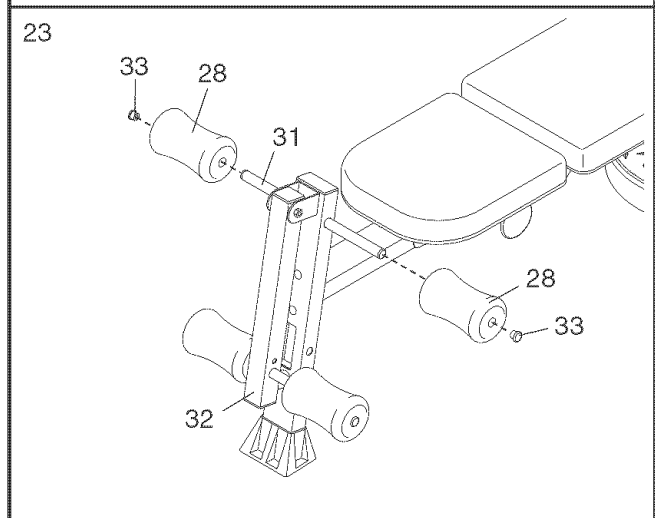

24. Adjust the tension on the upper cable (not shown) as described in UPPER CABLE ADJUSTMENT on the following page.

25. Make sure that all parts have been properly tightened. The use of the remaining parts will be explained in ADJUSTMENTS, beginning on page 15.

Before using the resistance system, pull the long cable a few times to be sure that it moves smoothly over the pulleys. If the cable does not move smoothly, find and correct the problem. **IMPORTANT: If the cables are not properly installed, they may be damaged when heavy resistance is used. See the CABLE DIAGRAM on page 18 for proper cable routing.**

UPPER CABLE ADJUSTMENT

After completing the assembly of the resistance system, the tension on the upper cable (B) will need to be adjusted. Also, the upper cable can stretch slightly when it is first used. When this occurs, the upper cable tension will need to be readjusted. Follow the steps below to adjust the upper cable tension.

1. Connect the two Tension Gauges (109, 110) together using the magnet.

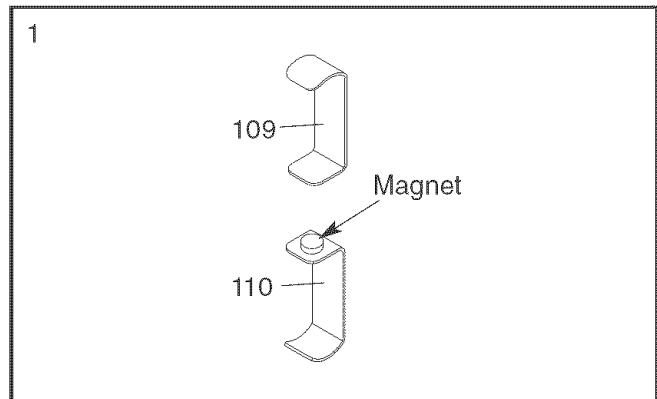

2. Plug in the resistance system as described in PLUGGING IN THE RESISTANCE SYSTEM on page 17. Use the Console (not shown) to adjust the resistance setting of the system to the highest setting, as described in ADJUSTING THE RESISTANCE on page 16.

Squeeze the upper cable (B) together near a Large Pulley (17). Hook the ends of the Tension Gauges (109, 110) around the upper cable as shown. **Do not hook the ends of the Tension Gauges around the Tether (61); which is attached to the back of the Pulley Bracket (10).**

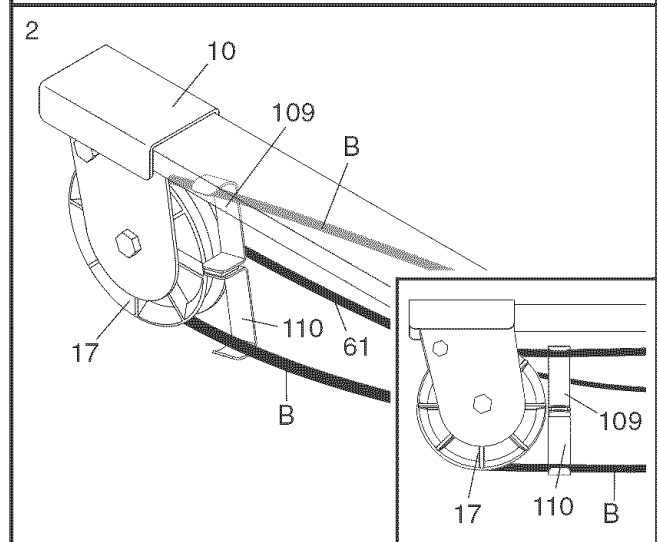

Slide the Tension Gauges (109, 110) next to the Large Pulley (17) as shown in the inset drawing.

3. Locate the 3/8" x 38mm Tension Screw (108) on each end of the Resistance Bar (9). Alternately tighten each Screw one turn at a time until the two Tension Gauges (109, 110) are pulled apart by the upper cable (B).

The upper cable tension is now properly adjusted.

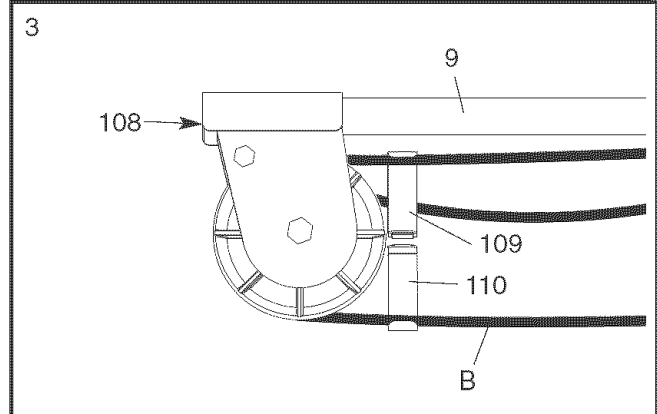

ADJUSTMENTS

This section explains how to adjust the resistance system. See the EXERCISE GUIDELINES on page 20 for important information about how to get the most benefit from your exercise program. Also, refer to the accompanying exercise guide to see the correct form for each exercise.

Make sure all parts are properly tightened each time the resistance system is used. Replace worn parts immediately. The resistance system can be cleaned with a damp cloth and a mild, non-abrasive detergent. Do not use solvents. The resistance bar can be cleaned with a vinyl and rubber protectant, available at an automotive or department store.

ATTACHING THE HIGH PULLEYS

To use a high pulley, slide the hook on the High Pulley Housing (52) onto the Eyebolt (51). Attach the end of the Short Cable (60) without the ball to the end of the long cable (C) with a Cable Clip (64). **Attach the other high pulley in the same manner.**

Remove the high pulleys when not in use.

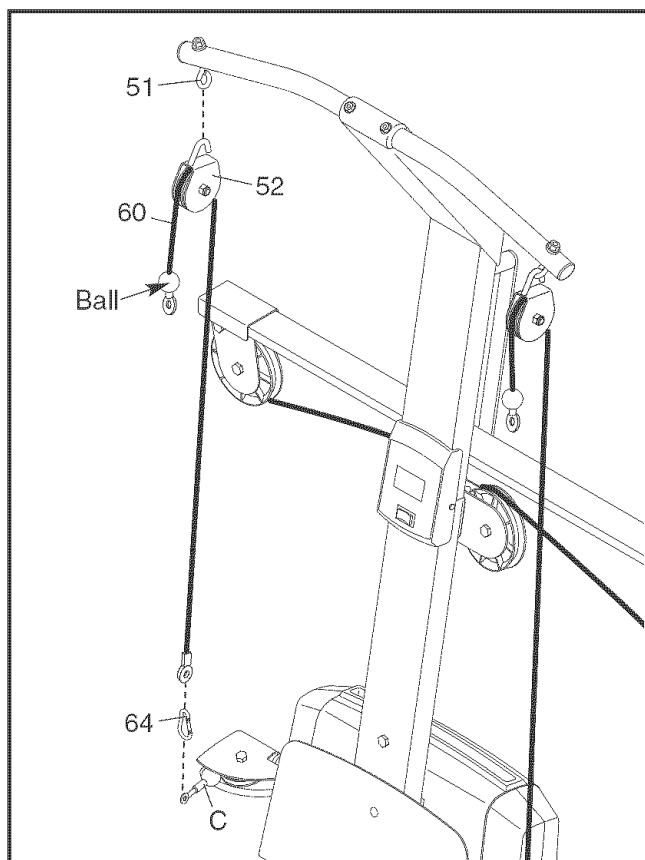

ADJUSTING THE SEAT

The Seat (41) can be secured in any of four positions on the Bench Rail (23). To move the Seat, pull the Seat Knob (43) out as far as it will go, and slide the Seat to the desired position. Engage the Seat Knob into an adjustment hole in the Bench Rail. **Note: It may be necessary to lift up on the Seat in order to engage the Seat Knob.**

To perform row exercises, the leg press strap must be attached to the long cable (see ATTACHING THE ACCESSORIES, on page 16), and the Seat Carriage (48) must be able to roll along the Bench Rail (23). First, remove the Backrest (40) from the Seat Carriage (see ADJUSTING THE BACKREST on page 15). Then, pull the Seat Knob (43) out as far as it will go, and turn the Knob so that the pin rests at the end of the "L"-shaped slot (see the inset drawing).

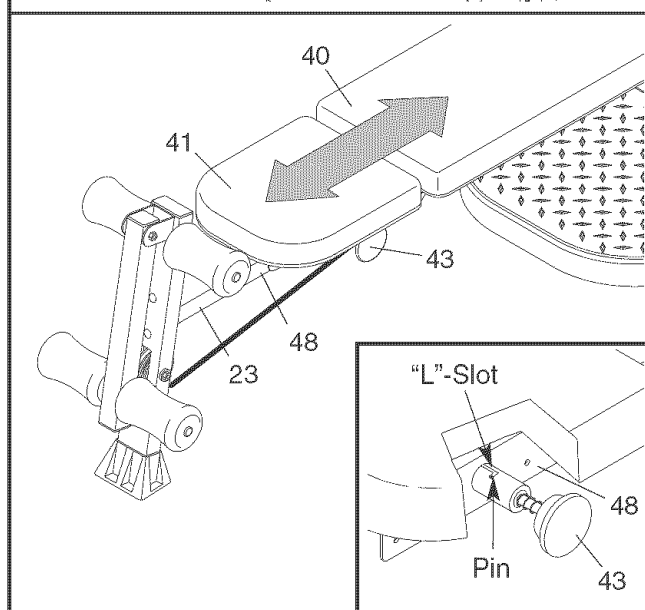

ATTACHING THE ACCESSORIES

To attach a Short Handle (67) to a high pulley, first attach the high pulley to the resistance system (see ATTACHING THE HIGH PULLEYS on page 13). Then, attach the Short Handle to the Short Cable (60) with a Cable Clip (64).

The Long Handles (not shown) and the Ankle Strap (not shown) can be attached to the long cable (not shown) with Cable Clips (64). Attach the Leg Press Strap (not shown) to both ends of the long cable, or the Lat Bar (not shown) to the Short Cables (60), with two Cable Clips.

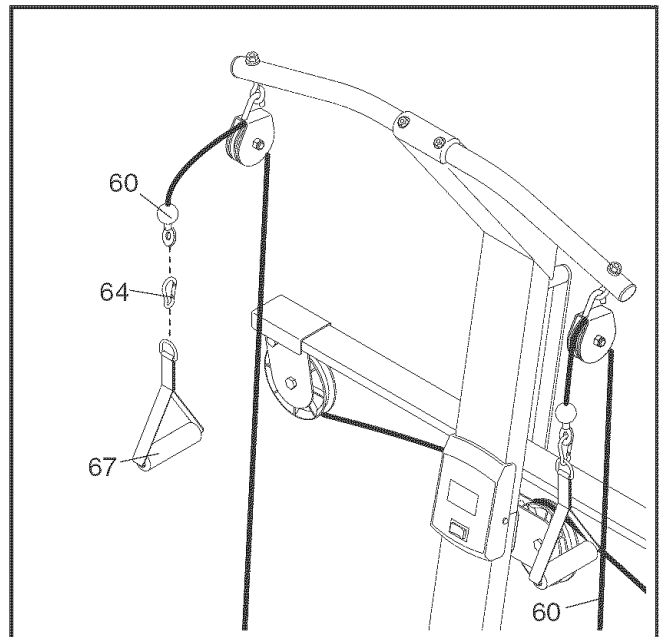

ATTACHING THE LEG LEVER

To use the Leg Lever (32), attach the two ends of the Leg Lever Cable (62) to the ends of the long cable (C) with two Cable Clips (64).

Detach the Leg Lever Cable (62) from the long cable (C) when the Leg Lever (32) is not in use. Store the ends of the Leg Lever Cable on the hook under the Bench Rail (23).

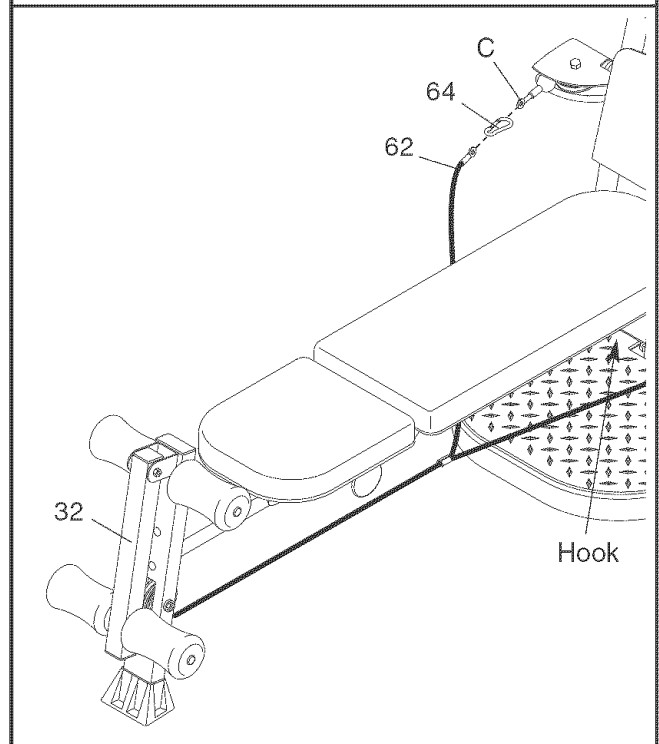

ADJUSTING THE RESISTANCE

To change the resistance setting, press the + / - switch on the Console (53). The display will show the current resistance level setting. The resistance can be increased up to 240 pounds.

Note: While the resistance setting is changing, the motor will be heard. **To prevent damage to the motor, do not pull any of the cables while the resistance setting is changing.**

Note: The resistance system uses progressive resistance. As the resistance bar begins to bend, the amount of resistance will increase gradually. As the bar bends further, the resistance will increase rapidly.

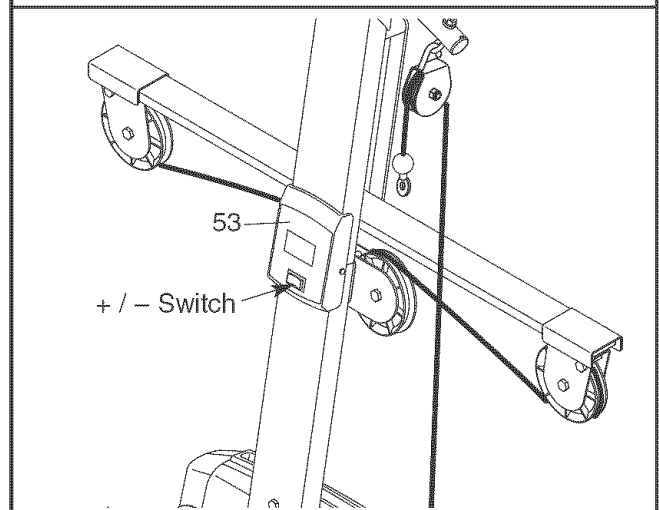

ADJUSTING THE BACKREST

The Backrest (40) can be used in a level position or one of three inclined positions. To use the Backrest in a level position, secure the Seat Carriage (48) to the adjustment hole in the Bench Rail (23) next to the Front Leg (31) (see ADJUSTING THE SEAT on page 13).

To use the Backrest (40) in an inclined position, secure the Seat Carriage (48) to one of the other three adjustment holes in the Bench Rail (23). Rest the Backrest against the Upright (3).

For row exercises, remove the Backrest (40). Hold the Backrest vertically over the Seat (41) and lift the rod out of the slot in the Seat Carriage (48) (see the inset drawing).

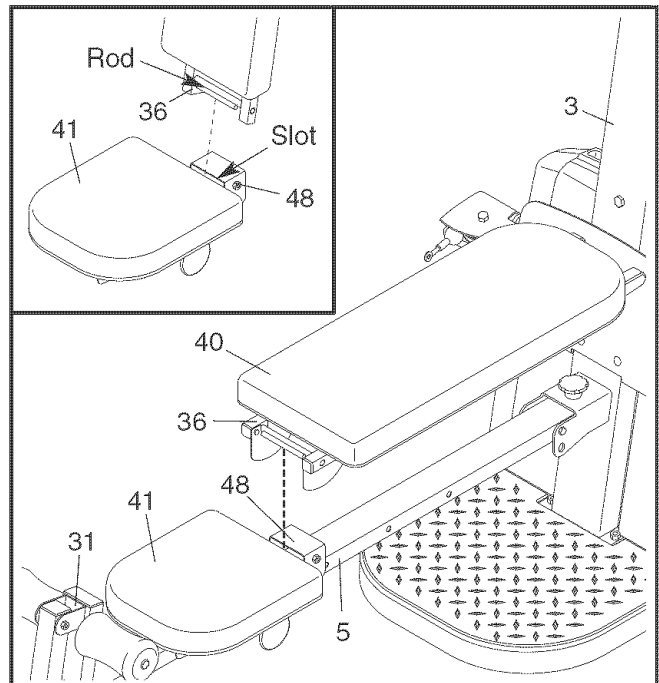

STORING THE RESISTANCE SYSTEM

To store the resistance system, slide the ends of the Leg Lever Cable (62) onto the hook on the bottom of the Bench Rail (23). Secure the Seat (41) in the position closest to the Front Leg (31) (see ADJUSTING THE SEAT on page 15). Next, remove the Storage Knob (26) from the Upright (3). Lift the Front Leg toward the Lat Tower Crossbar (49), and tighten the Storage Knob into the side of the Upright and the Bench Rail.

To move the resistance system, place the toe of your shoe on the end of the Base (1) and hold the resistance system in the indicated area. Tilt the resistance system back onto the Wheels (21) and roll it to the new location. **Be careful not to let the Front Leg (31) or Leg Lever (32) pinch your hands when you tilt the system back.**

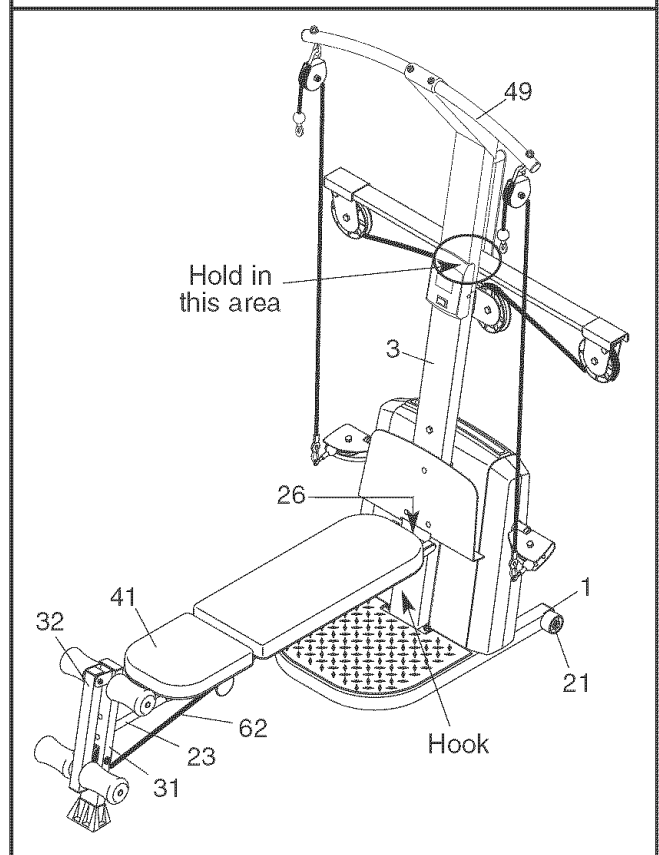

PLUGGING IN THE RESISTANCE SYSTEM

Plug the indicated end of the Transformer (12) into the Back Mech Cover (8). Plug the other end of the Transformer into a 120-volt outlet. The motor may be heard while the resistance system calibrates itself.

Important: Always plug in the transformer when using the resistance system, and unplug the transformer when finished.

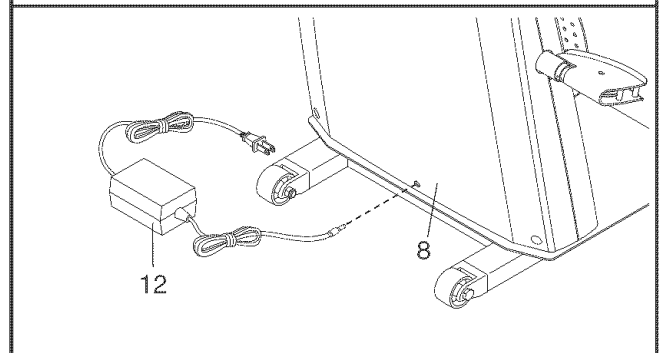

CABLE DIAGRAM

The cable diagram shows the proper routing of the upper cable (B). Use the diagram to make sure that the cable has been assembled correctly. If the cable has not been correctly routed, the resistance system will not function properly and damage may occur. The numbers show the correct route for the cable. **Make sure that the ends of the cable do not wrap around each other between positions 1 and 2, and 6 and 7.**

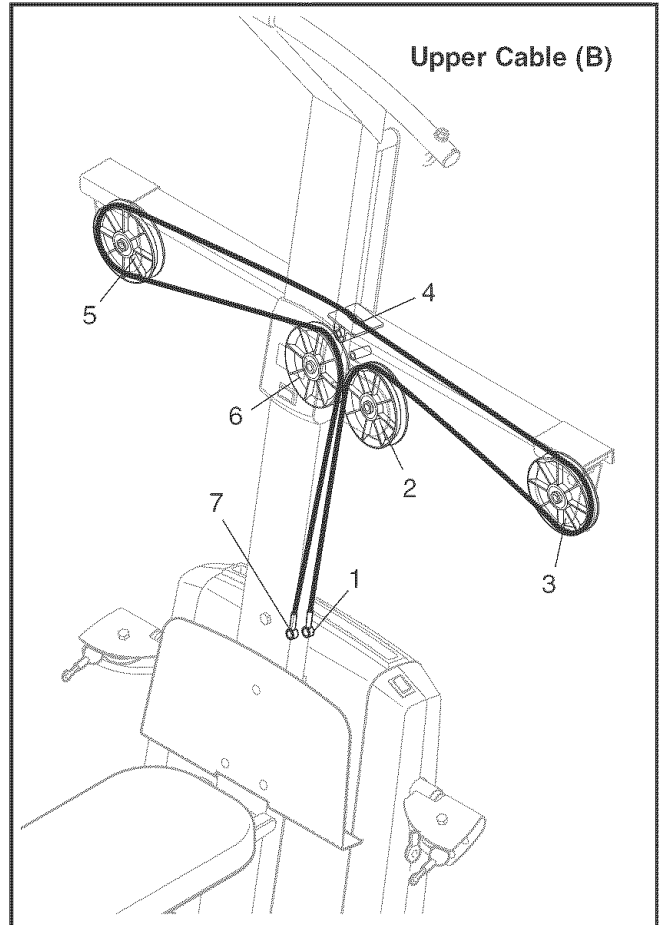

TROUBLESHOOTING

CLEANING THE BAR GUIDES

Over time, dust may build up on the Bar Guides (55), causing a squeaking noise as the resistance system is used. If this occurs, wipe off the Bar Guides with a damp cloth and a mild, non-abrasive detergent. Do not use solvents.

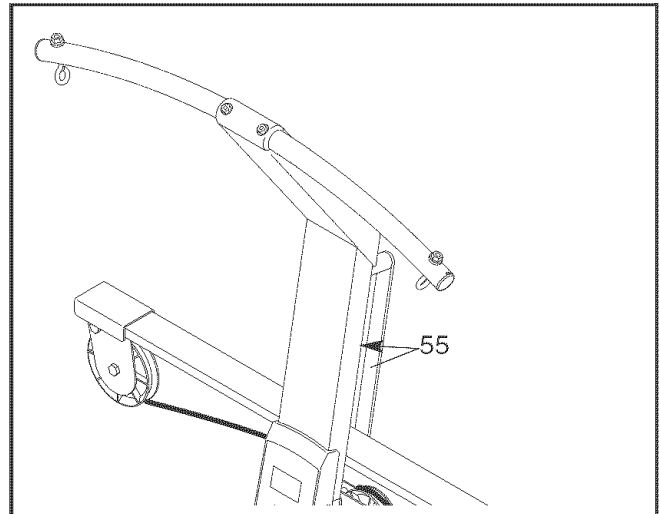

ADJUSTING THE RESISTANCE

When the resistance setting changes, the motor will be heard. **To prevent damage to the motor, do not pull any of the cables while the resistance setting is changing.** If the motor has difficulty adjusting the resistance level and no cable is being pulled, there may be too much tension on the upper cable (B). Adjust the tension as described below.

To decrease the tension on the upper cable (B), turn the two 3/8" x 38mm Tension Screws (108) twice, counterclockwise. Select the desired resistance setting. Repeat this step if necessary.

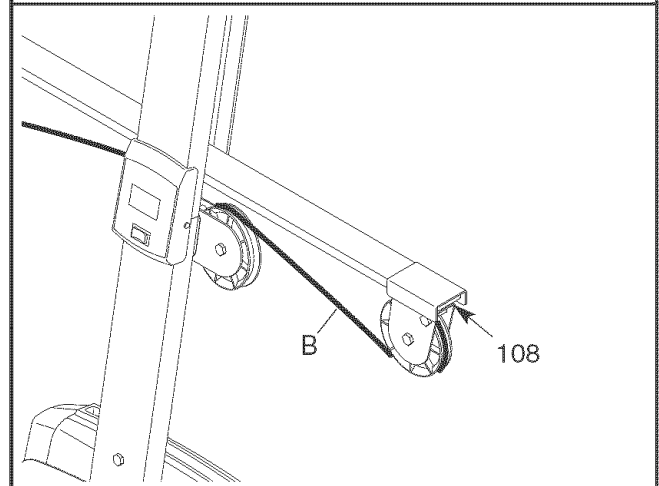

EXERCISE GUIDELINES

THE FOUR BASIC TYPES OF WORKOUTS

Muscle Building

To increase the size and strength of your muscles, push them close to their maximum capacity. Your muscles will continually adapt and grow as you progressively increase the intensity of your exercise. You can adjust the intensity level of an individual exercise in two ways:

- by changing the amount of resistance used
- by changing the number of repetitions or sets performed. (A “repetition” is one complete cycle of an exercise, such as one sit-up. A “set” is a series of repetitions.)

The proper amount of resistance for each exercise depends upon the individual user. You must gauge your limits and select the amount of resistance that is right for you. Begin with 3 sets of 8 repetitions for each exercise you perform. Rest for 3 minutes after each set. When you can complete 3 sets of 12 repetitions without difficulty, increase the amount of resistance.

Toning

You can tone your muscles by pushing them to a moderate percentage of their capacity. Select a moderate amount of resistance and increase the number of repetitions in each set. Complete as many sets of 15 to 20 repetitions as possible without discomfort. Rest for 1 minute after each set. Work your muscles by completing more sets rather than by using high amounts of resistance.

Weight Loss

To lose weight, use a low amount of resistance and increase the number of repetitions in each set. Exercise for 20 to 30 minutes, resting for a maximum of 30 seconds between sets.

Cross Training

Cross training is an efficient way to get a complete and well-balanced fitness program. An example of a balanced program is:

- Plan strength training workouts on Monday, Wednesday, and Friday.
- Plan 20 to 30 minutes of aerobic exercise, such as running on a treadmill or riding on an elliptical or exercise cycle, on Tuesday and Thursday.
- Rest from both strength training and aerobic exercise for at least one full day each week to give your body time to regenerate.

The combination of strength training and aerobic exercise will reshape and strengthen your body, plus develop your heart and lungs.

PERSONALIZING YOUR EXERCISE PROGRAM

Determining the exact length of time for each workout, as well as the number of repetitions or sets completed, is an individual matter. It is important to avoid overdoing it during the first few months of your exercise program. You should progress at your own pace and be sensitive to your body’s signals. If you experience pain or dizziness at any time while exercising, stop immediately and begin cooling down. Find out what is wrong before continuing. Remember that adequate rest and a proper diet are important factors in any exercise program.

WARMING UP

Begin each workout with 5 to 10 minutes of stretching and light exercise to warm up. Warming up prepares your body for more strenuous exercise by increasing circulation, raising your body temperature and delivering more oxygen to your muscles.

WORKING OUT

Each workout should include 6 to 10 different exercises. Select exercises for every major muscle group, emphasizing areas that you want to develop most. To give balance and variety to your workouts, vary the exercises from session to session.

Schedule your workouts for the time of day when your energy level is the highest. Each workout should be followed by at least one day of rest. Once you find the schedule that is right for you, stick with it.

EXERCISE FORM

Maintaining proper form is an essential part of an effective exercise program. This requires moving through the full range of motion for each exercise, and moving only the appropriate parts of the body. Exercising in an uncontrolled manner will leave you feeling exhausted. On the exercise guide accompanying this manual you will find photographs showing the correct form for several exercises, and a list of the muscles affected. Refer to the muscle chart on the next page to find the names of the muscles.

The repetitions in each set should be performed smoothly and without pausing. The exertion stage of each repetition should last about half as long as the return stage. Proper breathing is important. Exhale during the exertion stage of each repetition and inhale during the return stroke. Never hold your breath.

Rest for a short period of time after each set. The ideal resting periods are:

- Rest for three minutes after each set for a muscle building workout.
- Rest for one minute after each set for a toning workout.
- Rest for 30 seconds after each set for a weight loss workout.

Plan to spend the first couple of weeks familiarizing yourself with the equipment and learning the proper form for each exercise.

COOLING DOWN

End each workout with 5 to 10 minutes of stretching. Include stretches for both your arms and legs. Move

slowly as you stretch and do not bounce. Ease into each stretch gradually and go only as far as you can without strain. Stretching at the end of each workout is an effective way to increase flexibility.

STAYING MOTIVATED

For motivation, keep a record of each workout. The chart on pages 22 and 23 of this manual can be photocopied and used to schedule and record your workouts. List the date, the exercises performed, the resistance used, and the numbers of sets and repetitions completed. Record your weight and key body measurements at the end of every month. Remember, the key to achieving the greatest results is to make exercise a regular and enjoyable part of your everyday life.

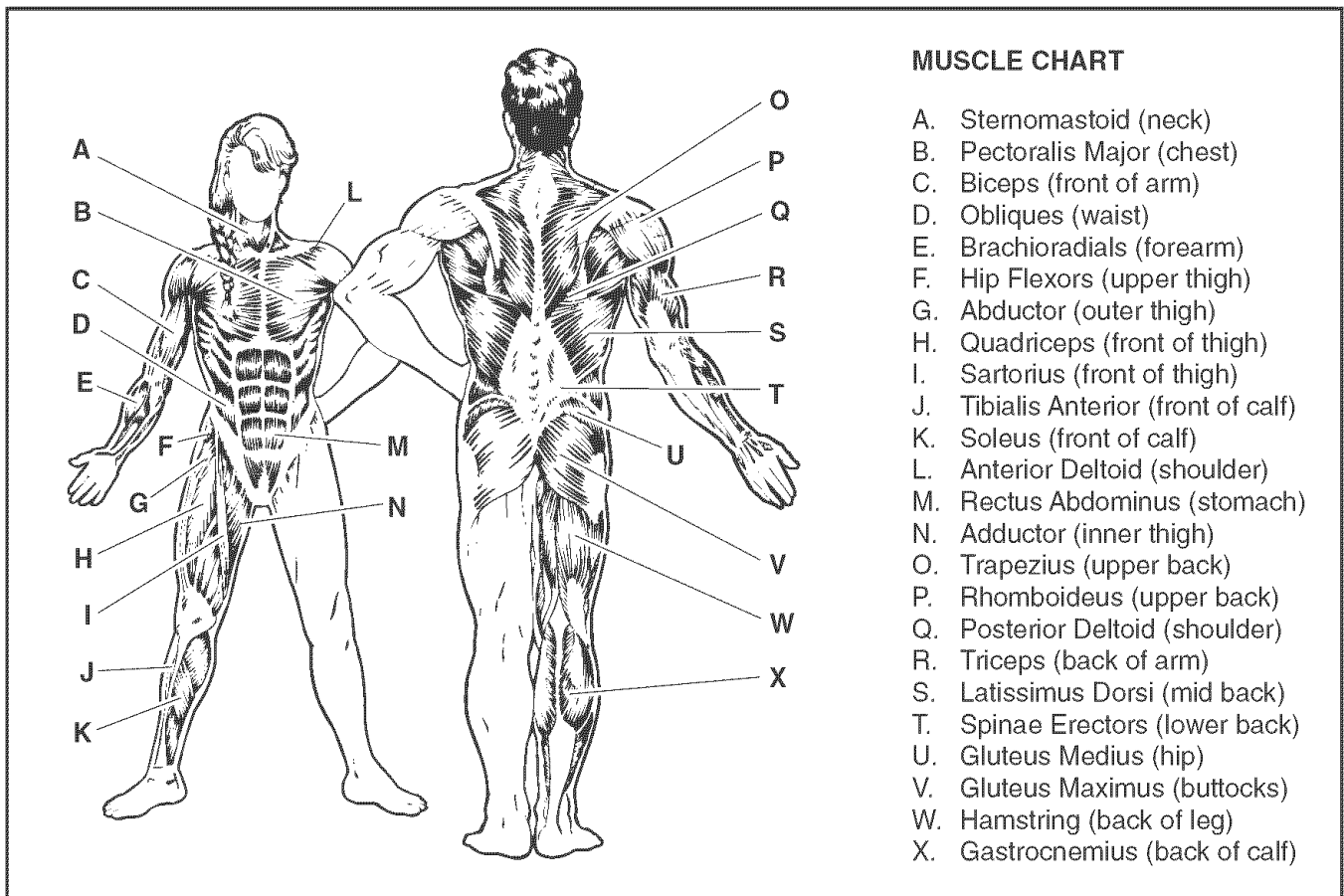

MONDAY	EXERCISE	WEIGHT	SETS	REPS
Date: _____ / _____ / _____				

TUESDAY **AEROBIC EXERCISE**
 Date: _____ / _____ / _____

WEDNESDAY	EXERCISE	WEIGHT	SETS	REPS
Date: _____ / _____ / _____				

THURSDAY **AEROBIC EXERCISE**
 Date: _____ / _____ / _____

FRIDAY	EXERCISE	WEIGHT	SETS	REPS
Date: _____ / _____ / _____				

Make photocopies of this page for scheduling and recording your workouts.

MONDAY	EXERCISE	WEIGHT	SETS	REPS
Date: _____ / _____ / _____				

TUESDAY **AEROBIC EXERCISE**
 Date: _____ / _____ / _____

WEDNESDAY	EXERCISE	WEIGHT	SETS	REPS
Date: _____ / _____ / _____				

THURSDAY **AEROBIC EXERCISE**
 Date: _____ / _____ / _____

FRIDAY	EXERCISE	WEIGHT	SETS	REPS
Date: _____ / _____ / _____				

Make photocopies of this page for scheduling and recording your workouts.

PART IDENTIFICATION CHART

Refer to the drawings below to identify small parts used in assembly. The number in parentheses by each drawing is the key number of the part, from the PART LIST in the center of this manual. **Note: Some small parts may have been pre-attached. If a part is not in the parts bag, check to see if it has been pre-attached. If a part is missing, call toll-free 1-877-992-5999.**

1/2" Nylon Jamnut (78)

M10 Nylon Locknut (71)

M6 Nylon Locknut (69)

M12 Nylon Locknut (72)

M4 x 16mm Screw (103)

M8 Nylon Locknut (70)

M10 Thick Washer (75)

M6 x 16mm Screw (11)

M6 x 13mm Bolt (105)

M8 Washer (76)

M10 Lock Washer (74)

3/8" x 38mm Tension Screw (108)

M6 x 45mm Screw (98)

M10 x 58mm Button Screw (85)

M10 x 58mm Screw (94)

M10 x 53mm Carriage Bolt (91)

M10 Washer (73)

M10 x 25mm Screw (100)

M10 x 62mm Button Bolt (80)

M10 x 63mm Button Bolt (82)

M10 x 65mm Button Bolt (96)

M10 x 69mm Bolt (93)

M10 x 72mm Bolt (87)

M10 x 66mm Carriage Bolt (89)

1/2" x 66mm Carriage Bolt (79)

M10 x 70mm Carriage Bolt (88)

M10 x 91mm Bolt (92)

M10 x 103mm Bolt (86)

M10 x 108mm Button Bolt (90)

M8 x 114mm Axle (102)

M10 x 152mm Bolt (83)

PART LIST—Model No. 831.153992

R0304B

Key No.	Qty.	Description	Key No.	Qty.	Description
1	1	Base	59	1	Cable Guide
2	1	Base Plate	60	2	Short Cable
3	1	Upright	61	2	Tether
4	1	Foot Plate	62	1	Leg Lever Cable
5	1	Lat Tower	63	2	Guard Plate
6	1	Mech Assembly	64	4	Cable Clip
7	1	Front Mech Cover	65	1	Ankle Strap
8	1	Back Mech Cover	66	1	Hip Strap
9	1	Resistance Bar	67	2	Short Handle
10	2	Pulley Bracket	68	2	Long Handle
11	4	M6 x 16mm Screw	69	2	M6 Nylon Locknut
12	1	Transformer	70	4	M8 Nylon Locknut
13	1	Upper Wire Harness	71	25	M10 Nylon Locknut
14	2	Pulley Pivot Bracket	72	4	M12 Nylon Locknut
15	2	Pivot Bracket Bushing	73	13	M10 Washer
16	5	Small Pulley	74	4	M10 Lock Washer
17	4	Large Pulley	75	3	M10 Thick Washer
18	1	Pulley Plate	76	2	M8 Washer
19	3	Plastic Foot	77	2	Handgrip
20	2	Large Plastic Foot	78	1	1/2" Nylon Jamnut
21	2	Wheel	79	1	1/2" x 66mm Carriage Bolt
22	2	50mm Square Inner Cap	80	2	M12 x 62mm Button Bolt
23	1	Bench Rail	81	2	M12 x 58mm Button Bolt
24	2	38mm x 76mm Inner Cap	82	2	M10 x 63mm Button Bolt
25	2	M10 x 42mm Button Bolt	83	2	M10 x 152mm Bolt
26	1	Storage Knob	84	2	M10 x 44mm Button Bolt
27	2	38mm Round Inner Cap	85	1	M10 x 58mm Button Screw
28	4	Foam Pad	86	1	M10 x 103mm Bolt
29	1	Front Leg Foot	87	2	M10 x 72mm Bolt
30	1	Leg Lever Bumper	88	3	M10 x 70mm Carriage Bolt
31	1	Front Leg	89	2	M10 x 66mm Carriage Bolt
32	1	Leg Lever	90	2	M10 x 108mm Button Bolt
33	4	19mm Round Inner Cap	91	2	M10 x 53mm Carriage Bolt
34	2	45mm Square Inner Cap	92	1	M10 x 91mm Bolt
35	2	26mm Spacer	93	1	M10 x 69mm Bolt
36	1	Backrest Frame	94	1	M10 x 58mm Bolt
37	2	25mm Square Inner Cap	95	2	M8 x 104mm Button Bolt
38	1	Backrest Cap	96	2	M10 x 65mm Button Bolt
39	1	Backrest Backing	97	4	M4 x 20mm Screw
40	1	Backrest	98	4	M6 x 45mm Screw
41	1	Seat	99	2	M4 x 7mm Machine Screw
42	1	Seat Backing	100	4	M10 x 25mm Screw
43	1	Seat Knob	101	2	M4 x 5mm Round Head Screw
44	3	60mm Metal Spacer	102	1	M8 x 114mm Axle
45	6	8mm Metal Spacer	103	17	M4 x 16mm Screw
46	6	Bearing Wheel	104	1	M4 x 19mm Screw
47	2	M8 Flange Nut	105	2	M6 x 13mm Bolt
48	1	Seat Carriage	106	1	Angled Inner Cap
49	1	Lat Tower Crossbar	107	1	Lat Bar
50	1	Crossbar Cover	108	2	3/8" x 38mm Tension Screw
51	2	Eyebolt	109	1	Tension Gauge
52	2	High Pulley Housing	110	1	Tension Gauge w/magnet
53	1	Console	#	1	User's Manual
54	1	38mm Spacer	#	1	Exercise Guide
55	2	Bar Guide	#	1	Exercise Decal
56	2	Small Guide Spacer	#	1	Large Allen Wrench
57	1	Large Guide Spacer	#	1	Small Allen Wrench
58	1	Block Spacer			

Note: “#” indicates a non-illustrated part. Specifications are subject to change without notice. See the back cover of this manual for information about ordering replacement parts. If a part is missing, call toll-free 1-877-992-5999.

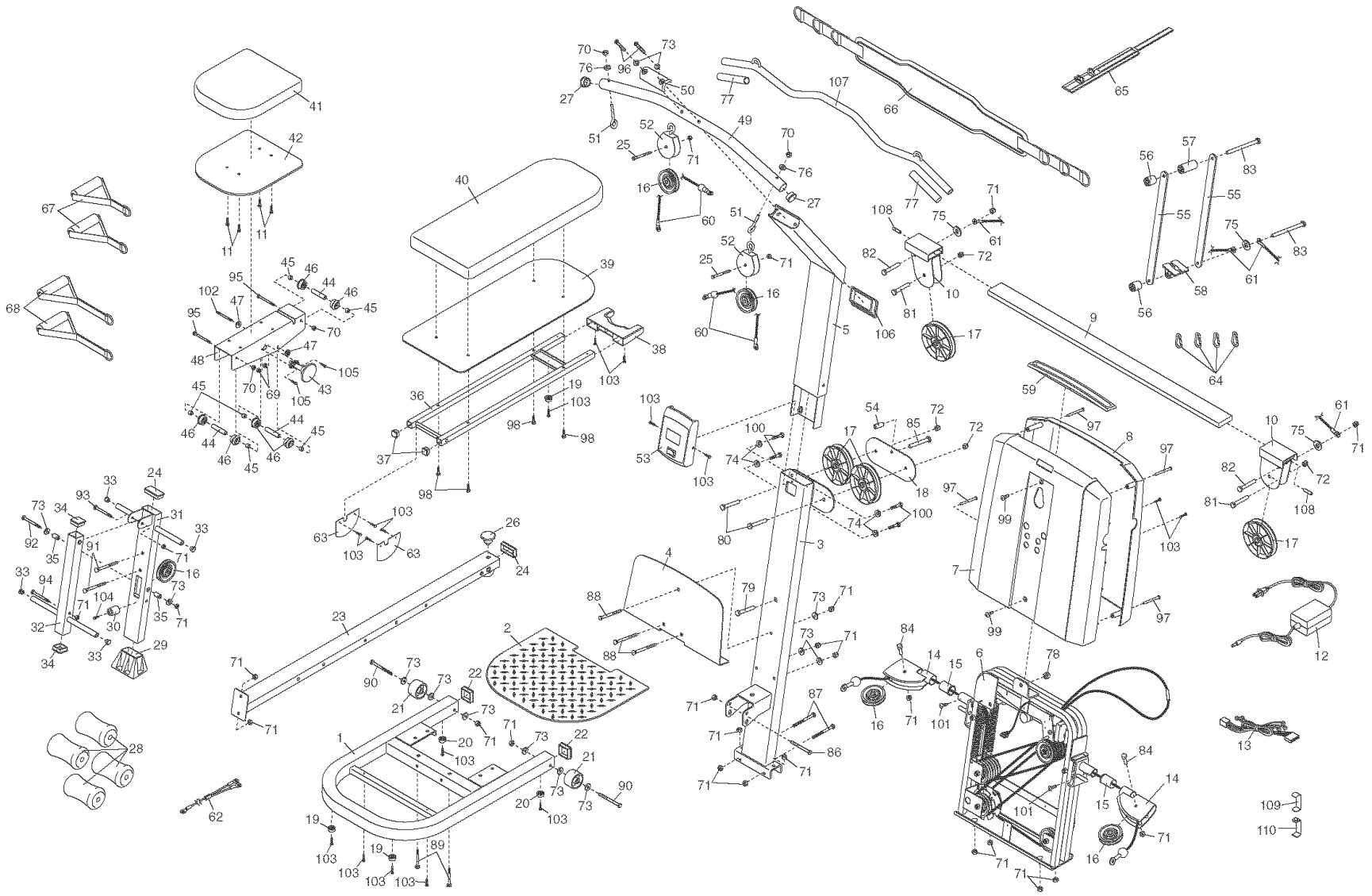

EXPLODED DRAWING—Model No. 831.153992

R0304B

Get it fixed, at your home or ours!

Your Home

For repair – **in your home** – of **all** major brand appliances, lawn and garden equipment, or heating and cooling systems, **no matter who made it, no matter who sold it!**

For the replacement parts, accessories, and user's manuals that you need to do-it-yourself.

For Sears professional installation of home appliances and items like garage door openers and water heaters.

1-800-4-MY-HOME®

(1-800-469-4663)

www.sears.com

Anytime, day or night

(U.S.A. and Canada)

www.sears.ca

Our Home

For repair of carry-in products like vacuums, lawn equipment, and electronics, call or go on-line for the location of your nearest **Sears Parts and Repair Center.**

1-800-488-1222 Anytime, day or night (U.S.A. only)

www.sears.com

To purchase a protection agreement (U.S.A.) or maintenance agreement (Canada) on a product serviced by Sears:

1-800-827-6655 (U.S.A.)

1-800-361-6665 (Canada)

Para pedir servicio de reparación a domicilio, y para ordenar piezas:

1-888-SU-HOGARSM (1-888-784-6427)

SEARS

® Registered Trademark / ™ Trademark / ™ Service Mark of Sears, Roebuck and Co.
© Marca Registrada / ™ Marca de Fábrica / ™ Marca de Servicio de Sears, Roebuck and Co.

FULL ONE-YEAR WARRANTY

For one year from the date of purchase, if failure occurs due to defect in material or workmanship in this RESISTANCE SYSTEM EXERCISER, contact the nearest Sears Service Center throughout the United States and Sears will repair or replace the RESISTANCE SYSTEM EXERCISER, free of charge. Parts will be replaced for five years. The resistance bar will be replaced for the lifetime of the product.

This warranty does not apply when the RESISTANCE SYSTEM EXERCISER is used commercially or for rental purposes; or if damage is caused by freight damage, abuse, misuse, improper or abnormal usage or unauthorized repairs.

This warranty gives you specific legal rights, and you may also have other rights which vary from state to state.

Sears, Roebuck and Co., Dept 817WA, Hoffman Estates, IL 60179