

Operator's Manual

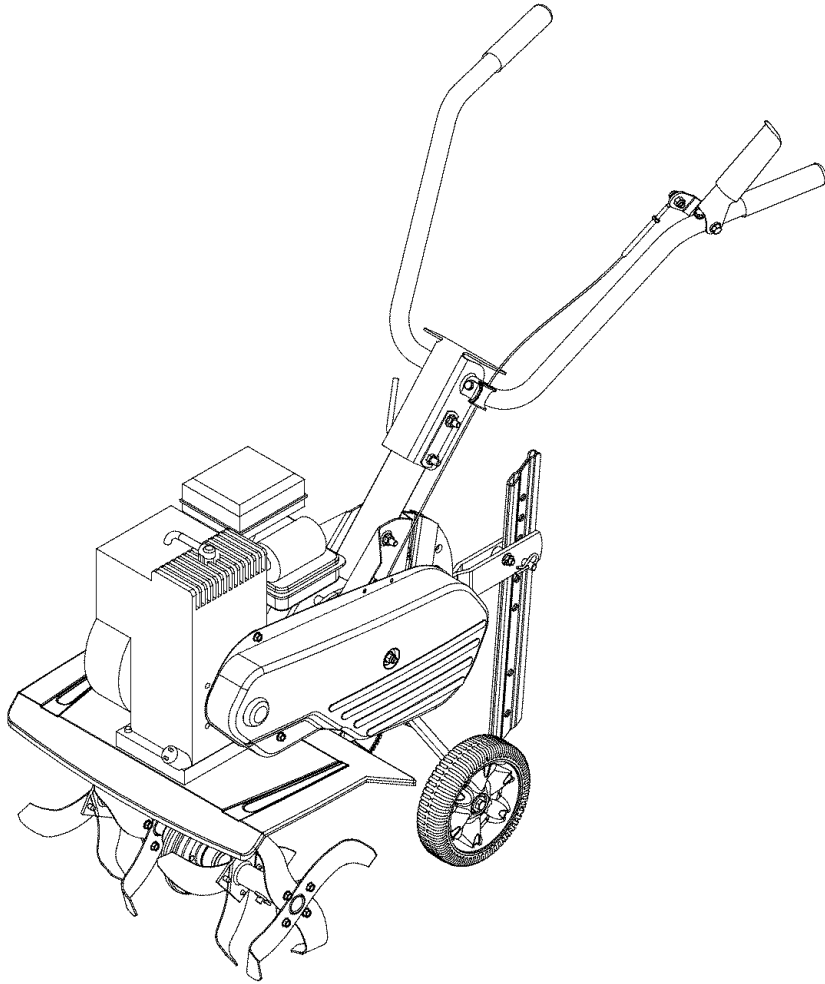

Front Tine Tiller

Model Series
300 & 330

IMPORTANT: Read safety rules and instructions carefully before operating equipment.

Warning: This unit is equipped with an internal combustion engine and should not be used on or near any unimproved forest-covered, brush-covered or grass-covered land unless the engine's exhaust system is equipped with a spark arrester meeting applicable local or state laws (if any). If a spark arrester is used, it should be maintained in effective working order by the operator. In the State of California the above is required by law (Section 4442 of the California Public Resources Code). Other states may have similar laws. Federal laws apply on federal lands. A spark arrester for the muffler is available through your nearest engine authorized service dealer or contact the service department, P.O. Box 361131 Cleveland, Ohio 44136-9722.

MTD LLC, P.O. BOX 361131 CLEVELAND, OHIO 44136-9722

TABLE OF CONTENTS

Content	Page	Content	Page
Important Safe Operation Practices	3	Maintaining Your Tiller	10
Assembling Your Tiller	5	Troubleshooting	11
Know Your Tiller	6	Illustrated Parts List	12
Operating Your Tiller	7	Warranty	16
Making Adjustments	9		

FINDING MODEL NUMBER

This Operator's Manual is an important part of your new tiller. It will help you assemble, prepare and maintain the unit for best performance. Please read and understand what it says.



Before you start assembling your new equipment, please locate the model plate on the equipment and copy the information from it in the space provided below. A sample model plate is also given below. You can locate the model plate by looking at the rear of the tine shield. This information will be necessary to use the manufacturer's web site and/or help from the Customer Support Department or an authorized service dealer.



Copy the model number here: _____

Copy the serial number here: _____

CUSTOMER SUPPORT

Please do NOT return the unit to the retailer without first contacting Customer Support.

If you have difficulty assembling this product or have any questions regarding the controls, operation or maintenance of this unit, you can seek help from the experts. Choose from the options below:

	<p>Visit mtdproducts.com for many useful suggestions. Click on Customer Support button and you will get the four options reproduced here. Click on the appropriate button and help is immediately available.</p> <div style="border: 1px solid black; padding: 5px; margin: 10px auto; width: 80%;"> <p>Find Answers Click here to search our knowledge base. Search by product, keyword, or phrase.</p> <p>My Stuff Login to check the status of your questions, modify your inquiries, or update your personal profile.</p> <p>Service Locator Need local assistance? Click here to find authorized service centers in your area.</p> <p>Manuals Online Need a manual and/or parts list? Download literature from recent model years.</p> </div> <p style="text-align: right; font-style: italic; margin-top: 10px;"><i>The answer you are looking for could be just a mouse-click away!</i></p>
	<p>If you prefer to reach a Customer Support Representative, please call (330) 220-4MTD or 1(800) 800-7310.</p>
	<p>The engine manufacturer is responsible for all engine-related issues with regard to performance, power-rating, specifications, warranty and service. Please refer to the engine manufacturer's Owner's/Operator's Manual, packed separately with your unit, for more information.</p>

SECTION 1: IMPORTANT SAFE OPERATION PRACTICES



WARNING: This symbol points out important safety instructions which, if not followed, could endanger the personal safety and/or property of yourself and others. Read and follow all instructions in this manual before attempting to operate this machine. Failure to comply with these instructions may result in personal injury. When you see this symbol— heed its warning.



WARNING: Engine exhaust, some of its constituents, and certain vehicle components contain or emit chemicals known to State of California to cause cancer and birth defects or other reproductive harm.

DANGER: This machine was built to be operated according to the rules for safe operation in this manual. As with any type of power equipment, carelessness or error on the part of the operator can result in serious injury. This machine is capable of amputating hands and feet. Failure to observe the following safety instructions could result in serious injury or death.

Training

1. Read, understand, and follow all instructions on the machine and in the manual(s) before attempting to assemble and operate. Keep this manual in a safe place for future and regular reference and for ordering replacement parts.
2. Be familiar with all controls and their proper operation. Know how to stop the machine and disengage them quickly.
3. Never allow children under 14 years old to operate this machine. Children 14 years old and over should read and understand the operation instructions and safety rules in this manual and should be trained and supervised by a parent.
4. Never allow adults to operate this machine without proper instruction.
5. Keep bystanders, helpers, pets and children at least 75 feet from the machine while it is in operation. Stop machine if anyone enters the area.
7. Use only an approved gasoline container.
8. Extinguish all cigarettes, cigars, pipes and other sources of ignition.
9. Never fuel machine indoors.
10. Never remove gas cap or add fuel while the engine is hot or running.
11. Allow engine to cool at least two minutes before refueling.
12. Never over fill fuel tank. Fill tank to no more than ½ inch below bottom of filler neck to provide space for fuel expansion.
13. Replace gasoline cap and tighten securely.
14. If gasoline is spilled, wipe it off the engine and equipment. Move machine to another area. Wait 5 minutes before starting the engine.
15. Never store the machine or fuel container inside near an open flame, spark or pilot light (e.g. furnace, water or space heater, clothes dryer etc.).
16. Allow machine to cool 5 minutes before storing.

Preparation

1. Thoroughly inspect the area where the equipment is to be used. Remove all stones, sticks, wire, and other foreign objects which could be tripped over and cause personal injury.
2. Wear sturdy, rough-soled work shoes and close fitting slacks and shirt. Loose fitting clothes or jewelry can be caught in movable parts. Never operate this machine in bare feet or sandals.
3. Disengage clutch levers and shift (if provided) into neutral (“N”) before starting the engine.
4. Never leave this machine unattended with the engine running.
5. Never attempt to make any adjustments while engine is running, except where specifically recommended in the operator’s manual.
6. To avoid personal injury or property damage use extreme care in handling gasoline. Gasoline is extremely flammable and the vapors are explosive. Serious personal injury can occur when gasoline is spilled on yourself or your clothes which can ignite. Wash your skin and change clothes immediately.

Operation

1. Do not put hands or feet near rotating parts. Contact with the rotating parts can amputate hands and feet.
2. Do not operate machine while under the influence of alcohol or drugs.
3. Never operate this machine without good visibility or light. Always be sure of your footing and keep a firm hold on the handles.
4. Keep bystanders, helpers, pets, and children at least 75 feet from the machine while it is in operation. Stop the machine if anyone enters the area.
5. Be careful when tilling in hard ground. The tines may catch in the ground and propel the tiller forward. If this occurs, let go of the handle bars and do not restrain the machine.
6. Exercise extreme caution when operating on or crossing gravel surfaces. Stay alert for hidden hazards or traffic. Do not carry passengers.
7. Never operate the machine at high transport speeds on hard or slippery surfaces.
8. Exercise caution to avoid slipping or falling.

9. Look down and behind and use care when in reverse or pulling machine towards you.
10. Start the engine according to the instructions found in this manual and keep feet well away from the tines at all times.
11. After striking a foreign object, stop the engine, disconnect the spark plug wire and ground against the engine. Thoroughly inspect the machine for any damage. Repair the damage before starting and operating.
12. Disengage all clutch levers and stop engine before you leave the operating position (behind the handles). Wait until the tines come to a complete stop before unclogging the tines, making any adjustments, or inspections.
13. Never run an engine indoors or in a poorly ventilated area. Engine exhaust contains carbon monoxide, an odorless and deadly gas.
14. Muffler and engine become hot and can cause a burn. Do not touch.
15. Use caution when tilling near fences, buildings and underground utilities. Rotating tines can cause property damage or personal injury.
16. Do not overload machine capacity by attempting to till soil to deep at to fast of a rate.
17. If the machine should start making an unusual noise or vibration, stop the engine, disconnect the spark plug wire and ground it against the engine. Inspect thoroughly for damage. Repair any damage before starting and operating.
18. Keep all shields, guards and safety devices in place and operating properly.
19. Never pick up or carry machine while the engine is running.
20. Use only attachments and accessories approved by the manufacturer. Failure to do so, can result in personal injury.
21. If situations occur which are not covered in this manual, use care and good judgment. Contact your dealer or telephone 1-800-800-7310 for assistance and the name of your nearest servicing dealer.

Maintenance & Storage

1. Never tamper with safety devices. Check their proper operation regularly.
2. Check bolts and screws for proper tightness at frequent intervals to keep the machine in safe working condition. Also, visually inspect machine for any damage.
3. Before cleaning, repairing, or inspecting, stop the engine and make certain the tines and all moving parts have stopped. Disconnect the spark plug wire and ground it against the engine to prevent unintended starting.

4. Do not change the engine governor settings or over-speed the engine. The governor controls the maximum safe operating speed of the engine.
5. Maintain or replace safety and instruction labels, as necessary.
6. Follow this manual for safe loading, unloading, transporting, and storage of this machine.
7. Never store the machine or fuel container inside where there is an open flame, spark or pilot light such as a water heater, furnace, clothes dryer etc.
8. Always refer to the operator's manual for proper instructions on off-season storage.
9. If the fuel tank has to be drained, do this outdoors.
10. Observe proper disposal laws and regulations for gas, oil, etc. to protect the environment.

Your Responsibility

1. Restrict the use of this power machine to persons who read, understand and follow the warnings and instructions in this manual and on the machine.
2. The safety label on the tiller is reproduced below for your review. To ensure safe operation of the tiller, follow the instructions on all labels closely.

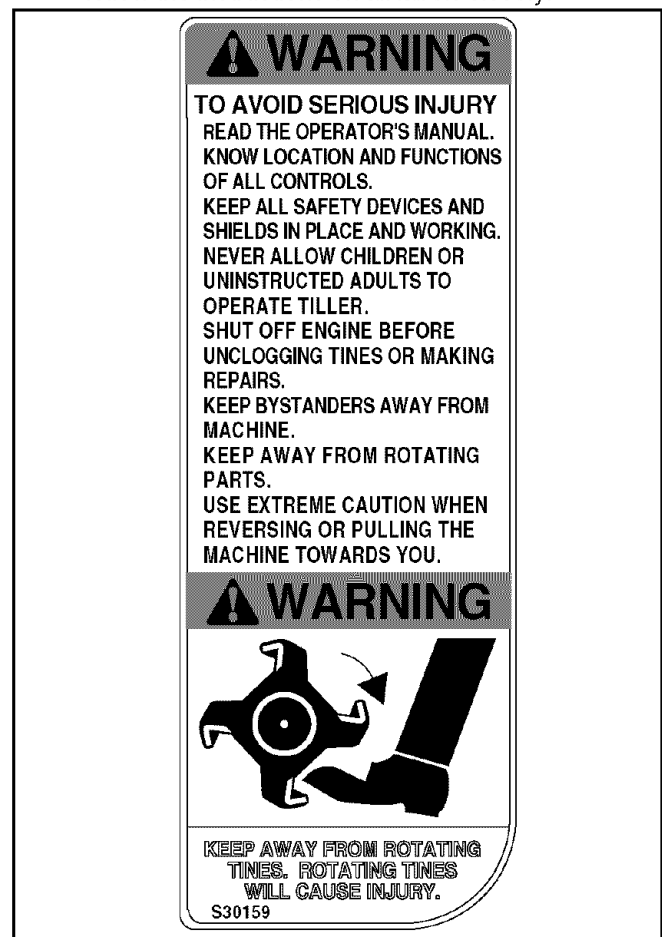

SECTION 2: ASSEMBLING YOUR TILLER

NOTE: This operator's manual covers various models of tillers. The units illustrated may vary slightly from your unit. Follow only those instructions which pertain to your model number.

NOTE: References to right or left side of the tiller are determined from behind the unit in the operating position.

IMPORTANT: This unit is shipped without gasoline or oil in the engine. Be certain to service engine with gasoline and oil as instructed in the separate engine manual before operating your machine.

Loose Parts In Carton

Tailpiece and Depth Stake

NOTE: All hardware needed for assembly is attached to the loose parts or the tiller.

Before Assembly



WARNING: Disconnect the spark plug wire and ground it against the engine to prevent unintended starting.

Assembling The Handle

- Remove the handle adjustment lever from handle and lift up upper handle to raise in operating position. See Figure 1.
- Reinsert adjustment lever through the lower hole, tightening the lever into lock nut on the retainer bracket.
- Once the lever is in the lock nut, the handle can be moved to the desired position and then tighten securely.

Attaching Tailpiece and Depth Stake

Tools Required For Assembly

(1) 1/2" socket wrench (or adjustable wrench)

- Remove the two self-tapping screws on the frame and slide the tailpiece into the frame, with the lower hole in the tailpiece toward the front. See Figure 2.
- Secure tailpiece with the screws just removed.

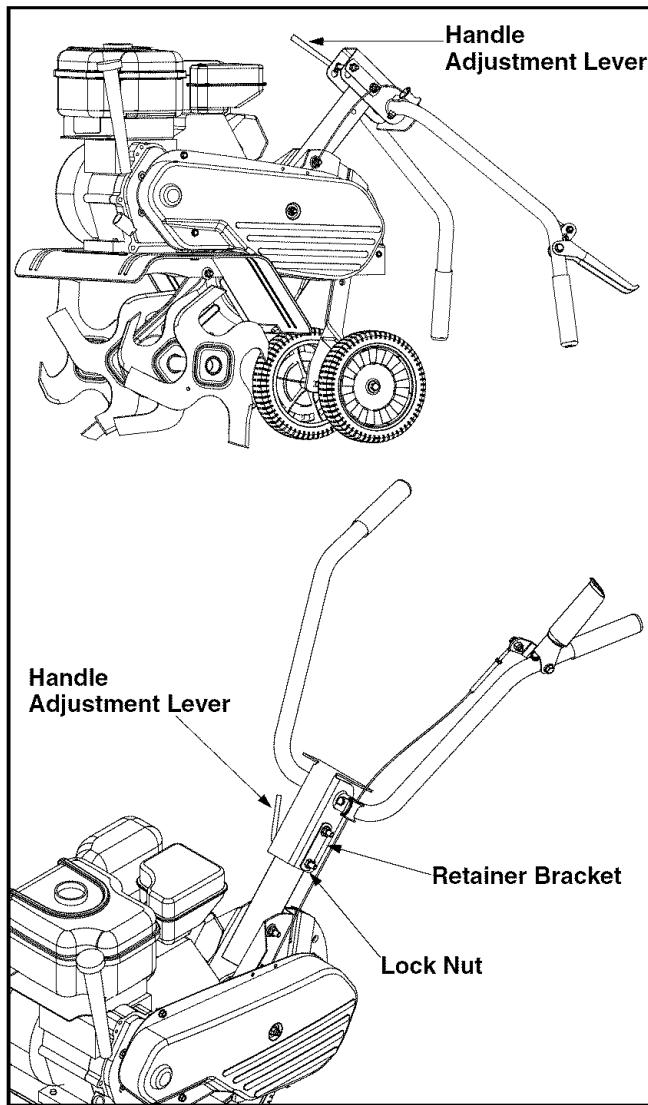

Figure 1

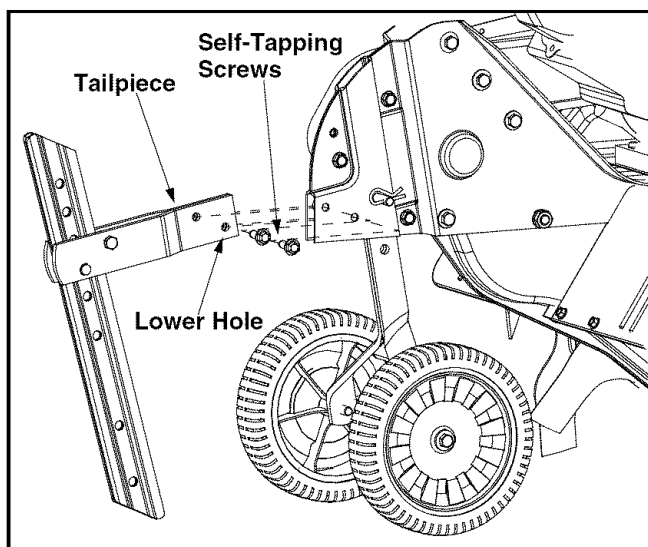

Figure 2

Check Cable Adjustment

- With the clutch lever disengaged, pull starter rope slowly several times. The tines should not turn. If they turn, the cable is not adjusted properly.
- To adjust the cable, loosen the nut near the top of the cable and unscrew the cable to provide additional slack in wire. See Figure 3.
- Tighten the nut and check again for proper adjustment.

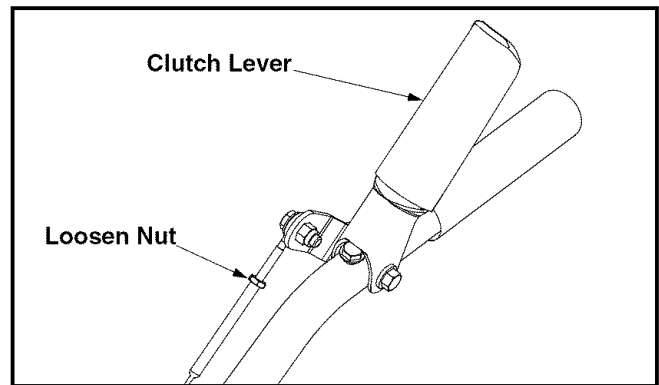

Figure 3

SECTION 3: KNOW YOUR TILLER

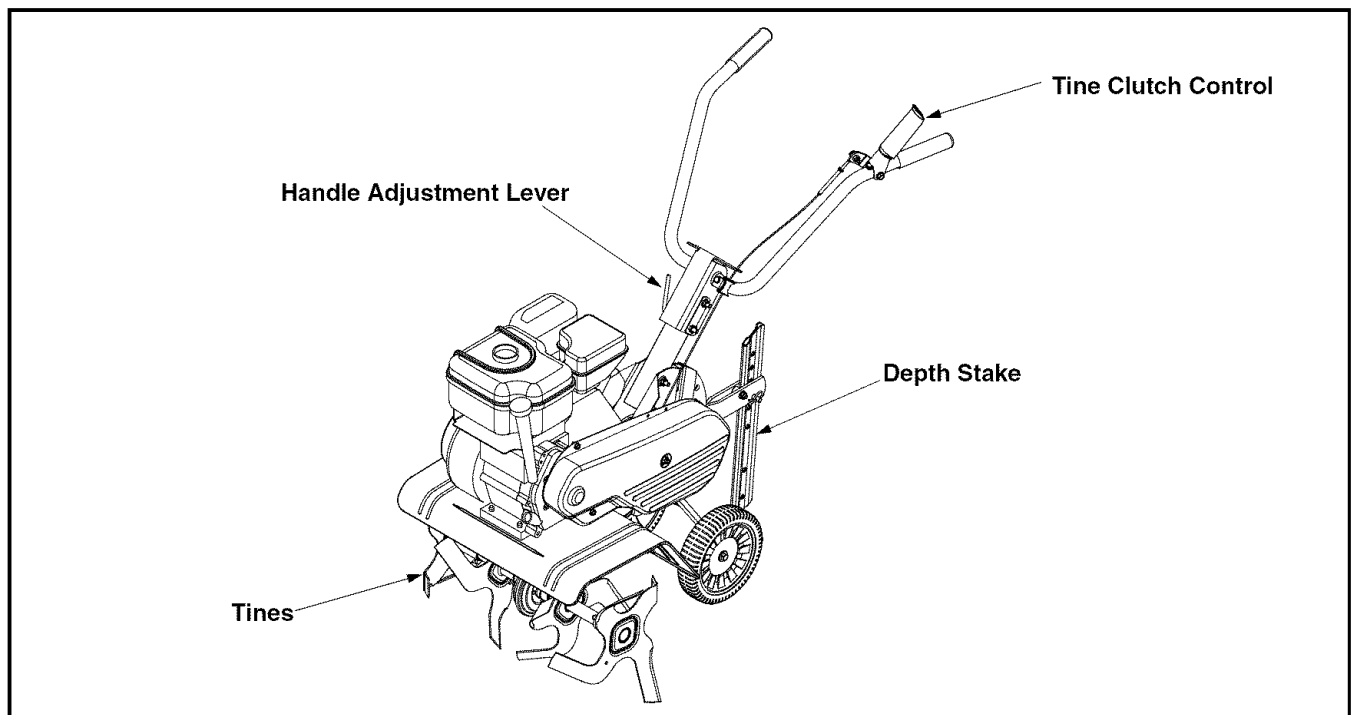

Figure 4



WARNING: Read, understand, and follow all instructions and warnings on the machine and in this manual before operating.

Tine Clutch Control

The clutch control lever is located on the left handle. Squeezing the lever against the handle engages the tine drive. Release the lever to stop the tines from turning. See Figure 4.

Depth Stake

The depth stake is located in the rear of the tiller and it controls the tilling depth. See Figure 4.

Handle Adjustment Lever

The handle may be adjusted to the height desired. Loosen the handle adjustment lever a few turns and pivot handle up or down to desired position. Tighten lock. See Figure 4.

Throttle Control

The throttle control lever is located on the engine. It controls the engine's speed and stops the engine.

- With the throttle control pushed completely forward, the carburetor is in START or FAST position. Use maximum engine speed for deep tilling.
- Pull the throttle control back to reduce engine speed to IDLE. Throttle control should be at IDLE for transporting the tiller.
- Pull the throttle completely back to stop the engine.

Choke Lever

The choke lever is located near the throttle control. It is used to enrich the fuel mixture when starting a cold engine.

Starter Handle

The starter handle is located on the engine and is used to manually start the engine.

Engine Controls

See the separate engine manual for additional information and functions of the engine controls.

SECTION 4: OPERATING YOUR TILLER



WARNING: Read, understand, and follow all instructions and warnings on the machine and in this manual before operating.

Before Starting

Gas And Oil Fill-Up

Service the engine with gasoline and oil as instructed in the separate engine manual packed with your tiller. Read instructions carefully.



WARNING: Use extreme care when handling gasoline. Gasoline is extremely flammable and the vapors are explosive. Never fuel machine indoors or while the engine is hot or running.

Starting Engine



WARNING: Be sure no one is standing in front of the tiller while the engine is running or being started.

- Attach spark plug wire to spark plug. Make sure the metal cap on the end of the spark plug is fastened securely over the metal tip on the spark plug.
- Make sure that the tine clutch control is disengaged.
- Place the throttle control in the FAST position.
- Move choke lever to CHOKE position. A warm engine requires little or no choke.
- Grasp starter handle and pull rope out slowly until engine reaches start of compression cycle (rope will pull slightly harder at this point). Let the rope rewind slowly.
- Pull rope with a rapid, continuous, full arm stroke. Keep a firm grip on starter handle. Let rope rewind slowly. Do not let starter handle snap back against starter. Repeat until engine starts.
- When engine starts, move choke lever on engine halfway between CHOKE and RUN. As the engine warms up, move the lever to RUN position.

NOTE: See your engine manual packed with your unit for more detailed instructions.

Stopping Engine

- Move throttle control lever to STOP or OFF position.
- Disconnect spark plug wire from spark plug and ground against the engine.

Using Your Tiller

Your tiller (also known as a cultivator) is a precision built machine designed for seed bed preparation, cultivating, furrowing and mulching. It is engineered to minimize the hardest work in the vegetable or flower garden, to till the soil for planting and cultivating, and to perform many other useful labor saving tasks in the garden.

Wheel Position

The tiller is shipped with the wheels adjusted such that the unit sits level. While tilling, as the tines enter the ground and the front of the tiller lowers, the wheels must be raised to level the unit, which is essential for proper engine operation. This adjustment is made by removing the clevis pin and hairpin clip from wheel yoke, raising the wheels to the desired height, and replacing the clevis pin and hairpin clip. See Figure 5.

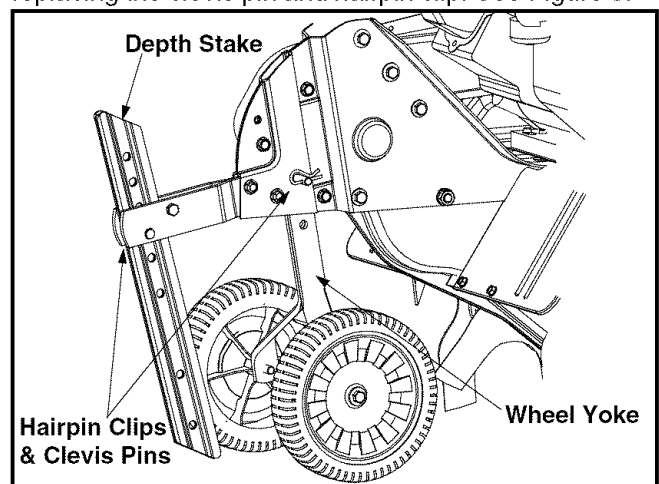

Figure 5

Controlling Speed And Tilling Depth

Wheel Yoke Adjustment

Place wheel yoke so that the wheels are forward (nearest point between wheels and tines) for shallow tilling, cultivating and transport. The forward speed will increase. Turn yoke around (farthest point between wheels and tines) for deep tilling. Forward speed will decrease. See Figure 6.

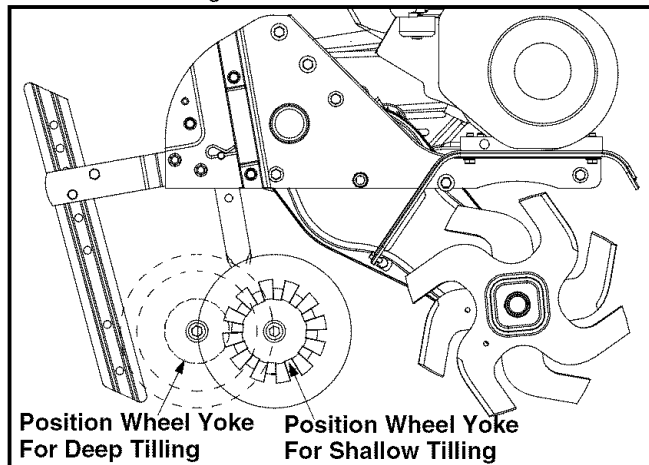

Figure 6

Depth Stake Adjustment

The depth stake acts as a brake for the tiller and controls the depth and speed at which the machine will operate. Remove the clevis pin and hairpin clip to raise or lower depth stake. Refer to Figure 5.

By increasing the depth of the depth stake, the forward speed of the machine is reduced and the working depth is increased. When the depth stake is raised, the working depth of the machine is reduced and the forward speed is increased. The working depth of the machine may be predetermined by setting the depth stake and wheels so that the wheels are about four inches from the ground when the tines and depth stake are resting on the ground. This setting will permit a working depth of about four inches. When presetting the working depth, the handles should be adjusted so the hand grips are a little above waist. The tiller will be lower when the tines and depth stake penetrate the ground. See Figure 7.

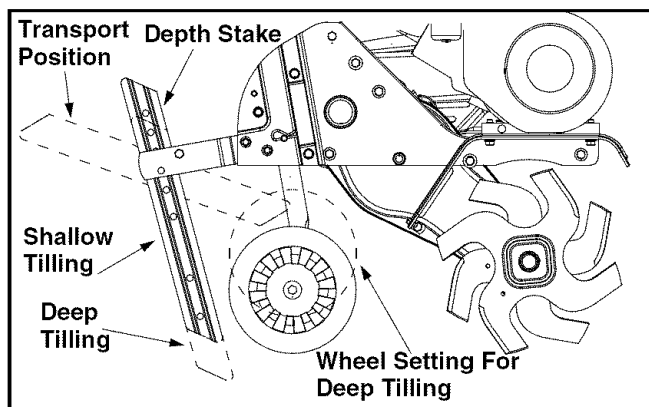

Figure 7

When tilling, leave approximately 8 inches of untilled soil between the first and second tilling paths, then make the third path between the first and second. In some soils, the desired depth is obtained the first time over the garden. In other soils, the desired depth is obtained by going over the garden two or three times. In the latter case, the depth stake should be lowered before each succeeding pass over the garden. Passes should be made across the length and width of the garden alternately. Rocks which are turned up should be removed from the garden area. See Figure 8.

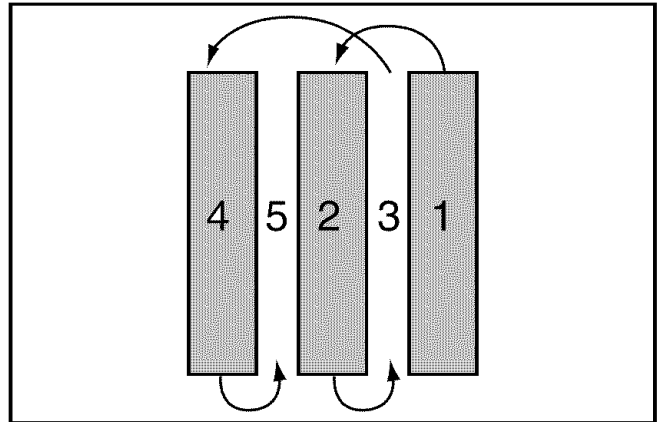

Figure 8

Handle Pressure

Further control of tilling depth and travel speed can be obtained by variation of pressure on the handles.

- A downward pressure on the handles will reduce the working depth and increase the forward speed.
- An upward pressure on the handles will increase the working depth and reduce the forward speed.

The type of soil and working conditions will determine the actual setting of the depth stake and the handle pressure required.

Transporting the Tiller

- To transport the tiller to or from the garden, pivot the depth stake forward and out of the way. With the throttle control in SLOW position, the unit will walk freely on the lawn. If the operator does not allow the tiller to move freely, the unit will start to till the surface. Refer to Figure 7.

Cultivating

For cultivating, a two to three inch depth is desirable. Setting the wheels and depth stake so that the wheels are about two inches above the ground while the tiller is resting on the tines and depth stake will allow the machine to work at cultivating depth. The throttle should be set to control forward movement to a slow walking speed. With the outer tines installed, the working width of the machine is 22 or 24 inches.

For cultivation, this may be reduced to 13 inches by removing the outer tines. Refer to the Adjustment Section. When laying out plant rows, be sure to allow enough width to permit cultivation between the rows. In growing corn or similar crops, check-row planting will permit cross cultivation and practically eliminate hand hoeing. See Figure 9.

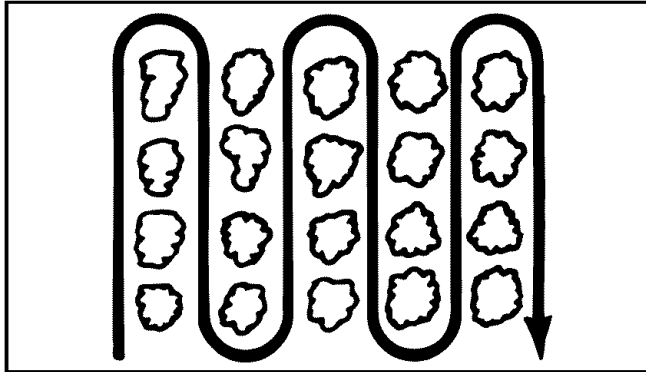

Figure 9

The tiller has many uses other than tilling and cultivating a garden. One of these is the preparation of lawn area for seeding. The tiller will prepare a deep seed bed which will be free of hard untilled spots, allowing a better stand of grass to grow. The tiller is very useful for loosening hard soil for excavation with a shovel. No tedious handwork will be necessary. Your tiller may be used for mixing compost in the pile, or for mixing it with the soil in your garden. This should be done after the soil has been broken to the full working depth. The compost should be worked in to a depth of six to seven inches. This may be done by working the length of the garden and then by making separate passes across its width. The addition of decayed organic matter will substantially increase the fertility of your garden. For proper decaying action, fertilizer should be applied and worked in with the mulch materials. Breaking up leaves and straw and mixing it with several inches of soil causes the soil to hold moisture longer and allows proper aeration of the plant root system. This also retards the growth of weeds.

SECTION 5: MAKING ADJUSTMENTS



WARNING: Disconnect the spark plug wire and ground it against the engine before performing any adjustments.

Engine Adjustment

Refer to the separate engine manual for engine adjustment instructions.

Wheel Adjustment

To adjust the wheel yoke and wheel position, refer to the Operating Section.

Depth Stake Adjustment

To adjust the depth stake to a desired position, refer to the Operating Section.

Clutch Control Adjustment

Periodic adjustment of the belt tension may be required due to normal stretch and wear on the belt. To adjust the clutch control lever, refer to the Assembly Section.

Tine Width Adjustment

The tilling width of the unit is 22 inches. Tilling width can be increased to 24 inches by removing the clevis pins and hairpin clips, sliding the outer tines out one inch, and securing in this position with the clevis pins and hairpin clips. For cultivation, reduce the tine width to 13 inches by removing the outer tines completely. See Figure 10.

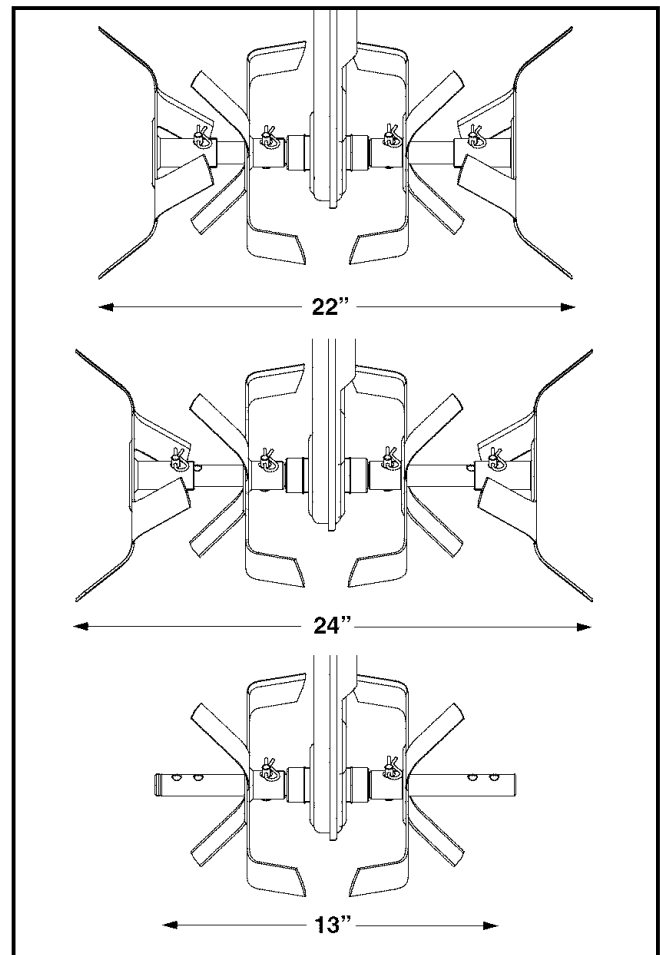

Figure 10

SECTION 6: MAINTAINING YOUR TILLER



WARNING: Disconnect the spark plug wire and ground it against the engine before performing any repairs or maintenance.

Engine

Refer to the separate engine manual for engine maintenance instructions.

Maintain **engine oil** as instructed in the separate engine manual packed with your unit. Read and follow instructions carefully.

Service **air cleaner** every ten hours under normal conditions. Clean every hour under extremely dusty conditions. Poor engine performance and flooding usually indicates that the air cleaner should be serviced. To service the air cleaner, refer to the separate engine manual packed with your unit.

IMPORTANT: Never run your engine without air cleaner completely assembled.

The **spark plug** should be cleaned and the gap reset every 25 hours of engine operation. Spark plug replacement is recommended at the start of each tiller season; check engine manual for correct plug type and gap specification.

Clean the engine regularly with a cloth or brush. Keep the cooling system (blower housing area) clean to permit proper air circulation which is essential to engine performance and life. Be certain to remove all dirt and combustible debris from muffler area.

Lubrication

Transmission

The transmission is pre-lubricated and sealed at the factory. It requires no checking. See an authorized service dealer for any service issues.

Clutch Handle

Lubricate the pivot point on the clutch handle and the cable at least once a season with light oil. The control must operate freely in both directions.

Pivot Points

Lubricate all pivot points and linkages at least once a season with light oil.

Tine Shafts

Remove tine assemblies and lubricate the tine shafts at least once a season.

Wheel Shafts

Remove wheel assemblies and lubricate the axle shafts at least once a season.

Cleaning Tine Area

Clean the underside of the tine shield after each use. The dirt washes off the tines easier if rinsed off immediately instead of after it dries. Always towel dry the tiller afterwards and apply a light coat of oil or silicone to prevent rusting or water damage.

IMPORTANT: Never use a "pressure washer" to clean your tiller. Water can penetrate tight areas of the tiller and its chain case and cause serious damage to the unit.

Belt Replacement

Your tiller has been engineered with a belt made of special material for longer life and better performance. It should not be replaced with an off-the-shelf belt. See the retailer from which you purchased your tiller, an authorized *MTD* Service Dealer or phone **1-800-800-7310** for information regarding price and availability.

- Remove the two hex washer screws from the front of the belt cover and remove the lock nut and flat washer from the side of the belt cover.
- Remove the belt cover. See Figure 11.

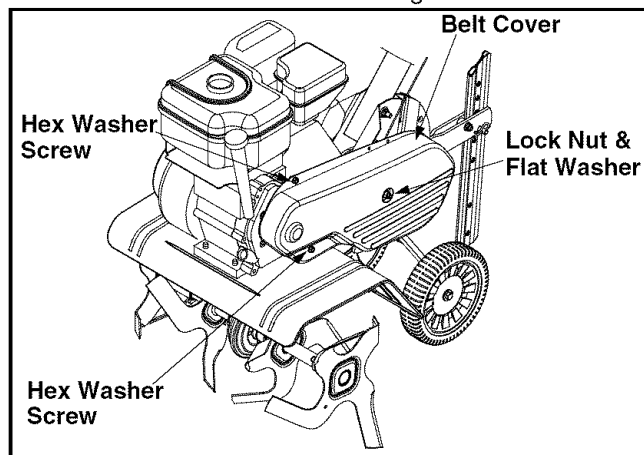

Figure 11

- Remove the hex screw and idler pulley from the idler bracket assembly. See Figure 12.

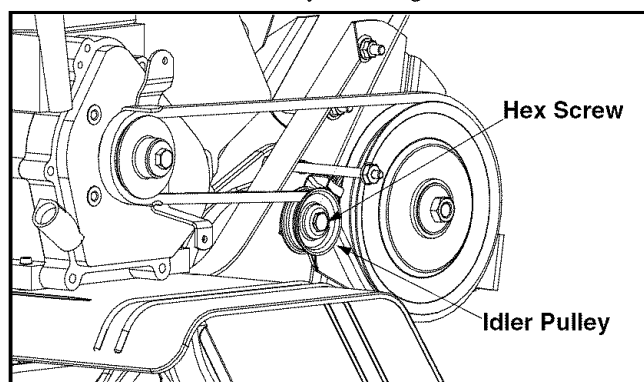

Figure 12

- Reassemble the new belt and reattach idler pulley to secure in place.
- Replace belt cover assembly and secure with the hardware removed earlier.

- Refer to the engine manual for correct engine storage instructions.
- Wipe tines with oiled rag to prevent rust.
- Store tiller in a clean, dry area. Do not store next to corrosive materials, such as fertilizer.

Off-Season Storage

If the tiller will not be used for a period longer than 30 days, the following steps should be taken to prepare the tiller for storage.

- Clean the exterior of engine and the entire tiller thoroughly. Lubricate the tiller as described in the lubrication instructions.
- We do not recommend the use of pressure washers to clean your unit. They may cause damage to spindles, pulleys, bearings or the engine. The use of pressure washers will result in shortened life and reduce serviceability.

NOTE: *When storing any type of power equipment in an unventilated or metal storage shed, care should be taken to rustproof the equipment. Using a light oil or silicone, coat the equipment and especially any springs, bearings, and cables.*

SECTION 7: TROUBLESHOOTING

Problem	Cause	Remedy
Engine fails to start	<ol style="list-style-type: none"> 1. Spark plug wire disconnected. 2. Fuel tank empty or stale fuel. 3. Throttle control lever not in correct starting position. (If equipped) 4. Choke not in ON position. 5. Blocked fuel line. 6. Faulty spark plug. 7. Engine flooded 	<ol style="list-style-type: none"> 1. Connect wire to spark plug. 2. Fill tank with clean, fresh gasoline. 3. Move throttle lever to start position. 4. Move lever to ON position. 5. Clean fuel line. 6. Clean, adjust gap, or replace. 7. Wait a few minutes to restart, but do not prime. (If Equipped)
Engine runs erratic	<ol style="list-style-type: none"> 1. Spark plug wire loose. 2. Unit running on CHOKE. 3. Blocked fuel line or stale fuel. 4. Vent plugged. 5. Water or dirt in fuel system. 6. Dirty air cleaner. 7. Carburetor out of adjustment. 	<ol style="list-style-type: none"> 1. Connect and tighten spark plug wire. 2. Move choke lever to OFF position. 3. Clean fuel line; fill tank with clean, fresh gasoline. 4. Clear vent. 5. Drain fuel tank. Refill with fresh fuel. 6. Clean following engine manual. 7. Refer to engine manual.
Engine overheats	<ol style="list-style-type: none"> 1. Engine oil level low. 2. Dirty air cleaner. 3. Air flow restricted. 4. Carburetor not adjusted properly. 	<ol style="list-style-type: none"> 1. Fill crankcase with proper oil. 2. Clean air cleaner. 3. Remove blower housing and clean. 4. Refer to engine manual.
Tines do not engage	<ol style="list-style-type: none"> 1. Foreign object lodged in tines. 2. Tine clevis pin(s) missing. 3. Control cable not adjusted properly. 4. Belt worn and/or stretched. 5. Pulley and idler not in correct adjustment. 	<ol style="list-style-type: none"> 1. Stop tiller completely, check and discard foreign object. 2. Replace tine clevis pin(s). 3. Adjust control cable. 4. Replace belt. 5. Take unit to authorized service dealer.

NOTE: *For repairs beyond the minor adjustments listed above, contact your nearest service dealer.*

SECTION 8: MODEL SERIES 300 & 330 PARTS LIST

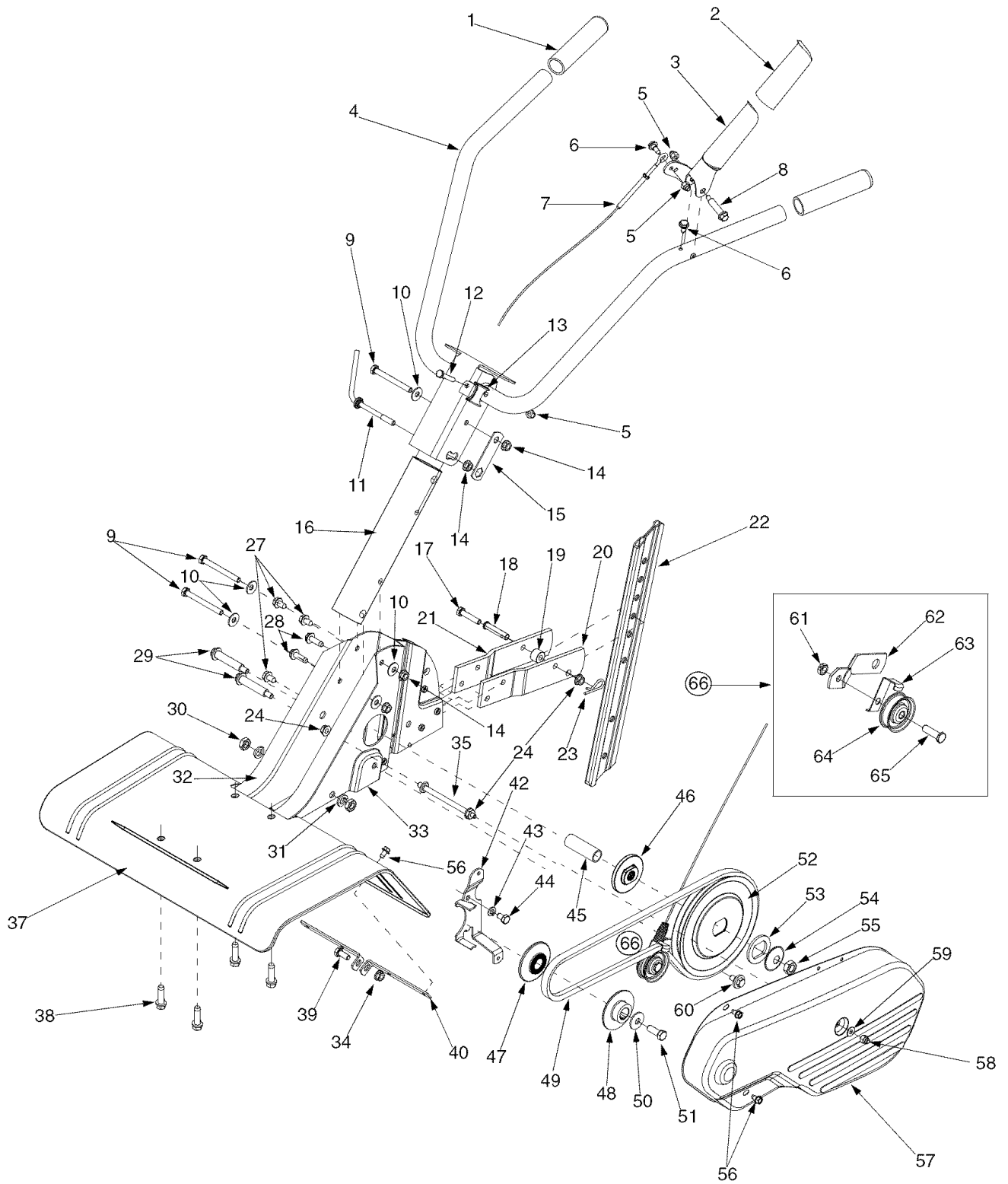

Model Series 300 & 330

Ref. No.	Part No.	Part Description	Ref. No.	Part No.	Part Description
1.	720-0274	Grip	35.	711-0919	Belt Cover Bolt
2.	731-0473	Clutch Grip	37.	786-0035A	Tine Shield 20"
3.	686-0002	Clutch Lever	38.	710-0502A	Hex Washer Screw 3/8-16 x 1.25
4.	649-0137	Handle Assembly	39.	710-3008	Hex Cap Screw 5/16-18
5.	712-0442	Lock Nut Cap 1/4-20	40.	786-0053	Tine Shield Bracket 20"
6.	738-1225	Shoulder Screw	42.	786-0039B	Cover Bracket
7.	746-1148	Clutch Cable	43.	736-0119	Lock Washer 5/16
8.	738-1226	Shoulder Screw	44.	710-0107	Hex Cap Screw 5/16-24 x.50
9.	710-0189	Hex Cap Screw 5/16-18 x 3.0	45.	750-0892	Input Spacer.64 ID x 2.4 Lg
10.	736-0242	Bell Washer.340 ID x.872 OD	46.	748-0350	Pulley Adapter
11.	786-0340	Adjustable Handle Crank	47.	756-0971	Engine Inner Half Pulley
12.	710-0606	Hex Cap Screw 1/4-20 x 1.5	48.	756-0972	Engine Outer Half Pulley
13.	719-0279	Rope Guide	49.	754-0428	Belt
14.	712-0720	Flange Nut 5/16-18	50.	736-0452	Bell Washer.396 ID x 1.140 OD
15.	786-0341	Retainer Bracket	51.	710-0152	Hex Cap Screw 3/8-24 x 1.0
16.	649-0136	Handle Tube	52.	756-0585	Flat Pulley
17.	710-0805	Hex Cap Screw 5/16-18 x 1.5	53.	736-0312	Retainer Bearing Washer
18.	711-0415	Clevis Pin 3/8 x 1.62	54.	736-0112	Spherical Washer.531 ID x.620 OD
19.	750-0890	Spacer	55.	712-3029	Jam Nut 1/2-20
20.	786-0003	Tailpiece Bracket LH	56.	710-0599	Hex Washer Screw 1/4-20 x.50
21.	786-0004	Tailpiece Bracket RH	57.	786-0056	Belt Cover
22.	786-0005	Depth Bar	58.	712-0392	Cap Lock Nut 1/4-28
23.	714-0149B	Cotter Pin	59.	736-3020	Flat Washer.271 ID x.630 OD
24.	712-3004A	Hex Flange Locknut 5/16-18	60.	738-0930	Shoulder Screw
27.	710-0604A	Hex Washer Screw 5/16-18 x.625	61.	712-0266	Jam Nut 3/8-16
28.	710-0602	Hex Washer Screw 5/16-18 x 1.0	62.	786-0144	Idler Bracket
29.	738-0934	Shoulder Screw	63.	786-0149	Idler Belt Keeper
30.	712-0240	Jam Nut 7/16-20	64.	756-0313	Flat Idler
31.	736-0171	Lock Washer 7/16	65.	710-0723	Hex Cap Screw 3/8-16 x 1.25
32.	786-0138A	Frame RH	66.	686-0088	Idler Bracket Assembly
33.	786-0139A	Frame LH			

Model Series 300 & 330

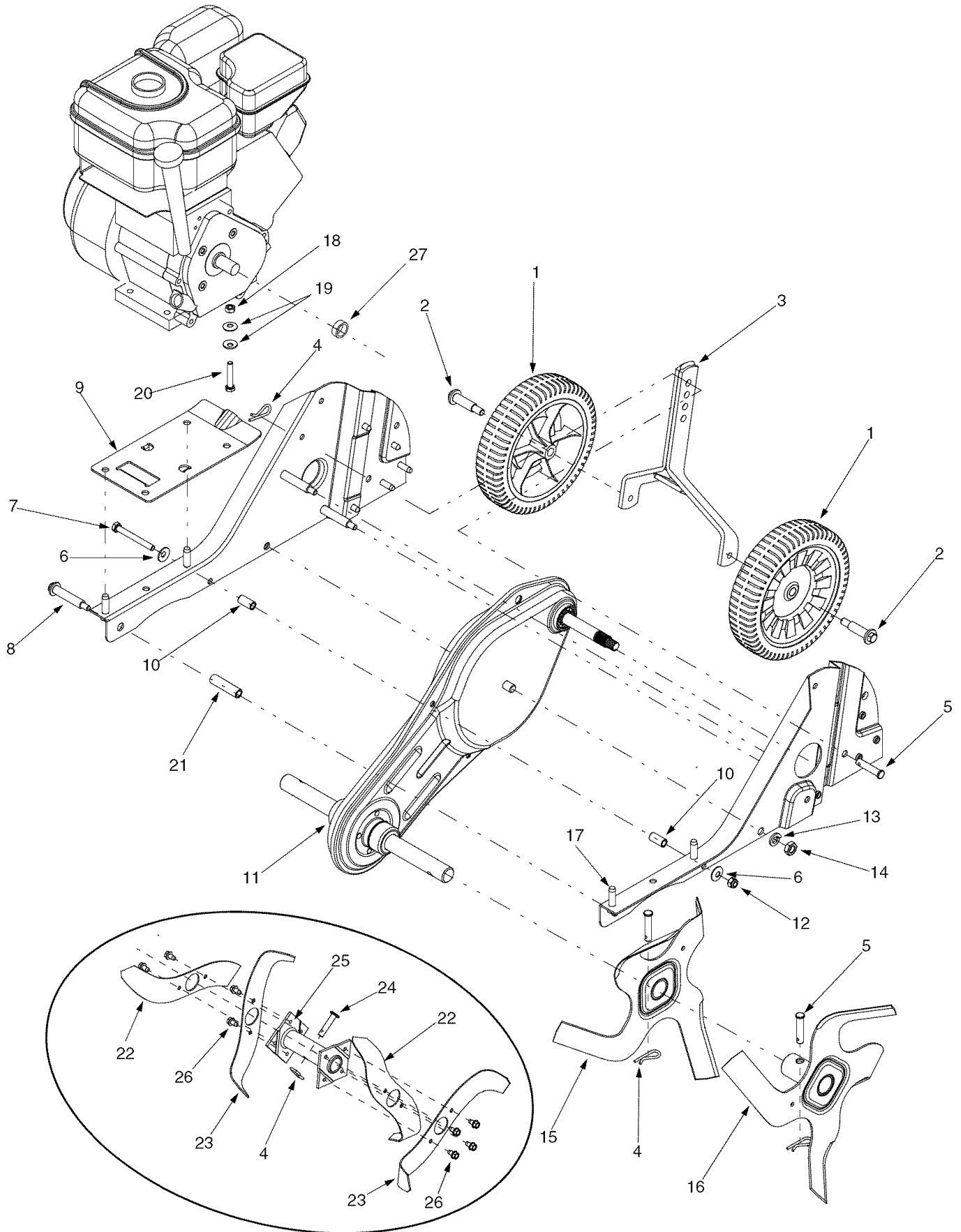

Model Series 300 & 330

Ref. No.	Part No.	Part Description	Ref. No.	Part No.	Part Description
1.	734-1988	Wheel 8 x 1.75	14.	712-0240	Jam Nut 7/16-20
	734-1781‡	Wheel 8 x 1.8	15.	642-0002‡	Inner Tine Assembly - RH 12"
2.	738-0929	Shoulder Screw		642-0003‡	Inner Tine Assembly - LH 12"
3.	686-0081A	Wheel Bracket Assembly	16.	642-0004‡	Outer Tine Assembly -RH 12"
4.	714-0149B	Cotter Pin		642-0005‡	Outer Tine Assembly - LH 12"
5.	711-0415	Clevis Pin	17.	710-0502A	Hex Washer Screw 3/8-16 x 1.25
6.	736-0242	Bell Washer.340 ID x.872 OD	18.	712-3010	Hex Nut 5/16-18
7.	710-0189†	Hex Cap Screw 5/16-18 x 3.0	19.	736-0242	Bell Washer.340 ID x.872 OD
	710-0176‡	Hex Cap Screw 5/16-18 x 2.75	20.	710-3180	Hex Cap Screw 5/16-18 x 1.75
8.	738-0934	Shoulder Screw	21.	750-0273†	Spacer, .51 x .69 x 1.97
9.	786-0145A	Engine Mounting Plate	22.	04922†	Tine 9.5" RH
10.	750-0470	Spacer.47 OD x.96Lg	23.	04923†	Tine 9.5" LH
11.	686-0189†	Chain Case Assembly	24.	711-0702†	Clevis Pin
	686-0091‡	Chain Case Assembly	25.	04918†	Tine Adapter
12.	712-0429	Hex Lock Nut 5/16-18	26.	710-0599†	Self-tapping Screw, 1/4-20 x .5
13.	736-0171	Lock Washer 7/16	27.	750-0456†	Spacer, .790 x .347

† Series 300 Only

‡ Series 330 Only

MANUFACTURER'S LIMITED WARRANTY FOR:



The limited warranty set forth below is given by MTD LLC with respect to new merchandise purchased and used in the United States, its possessions and territories.

“MTD” warrants this product against defects in material and workmanship for a period of two (2) years commencing on the date of original purchase and will, at its option, repair or replace, free of charge, any part found to be defective in materials or workmanship. This limited warranty shall only apply if this product has been operated and maintained in accordance with the Operator’s Manual furnished with the product, and has not been subject to misuse, abuse, commercial use, neglect, accident, improper maintenance, alteration, vandalism, theft, fire, water, or damage because of other peril or natural disaster. Damage resulting from the installation or use of any part, accessory or attachment not approved by MTD for use with the product(s) covered by this manual will void your warranty as to any resulting damage.

Normal wear parts are warranted to be free from defects in material and workmanship for a period of thirty (30) days from the date of purchase. Normal wear parts include, but not limited to items such as: batteries, belts, blades, blade adapters, grass bags, rider deck wheels, seats, snow thrower skid shoes, shave plates, auger spiral rubber and tires.

HOW TO OBTAIN SERVICE: Warranty service is available, WITH PROOF OF PURCHASE, through your local authorized service dealer. To locate the dealer in your area, check your Yellow Pages, or contact MTD LLC at P.O. Box 361131, Cleveland, Ohio 44136-0019, or call 1-800-800-7310 or 1-330-220-4683 or log on to our Web site at www.mtdproducts.com.

This limited warranty does **not** provide coverage in the following cases:

- a. The engine or component parts thereof. These items may carry a separate manufacturer’s warranty. Refer to applicable manufacturer’s warranty for terms and conditions.
- b. Log splitter pumps, valves, and cylinders have a separate one year warranty.
- c. Routine maintenance items such as lubricants, filters, blade sharpening, tune-ups, brake adjustments, clutch adjustments, deck adjustments, and normal deterioration of the exterior finish due to use or exposure.
- d. Service completed by someone other than an authorized service dealer.

- e. MTD does not extend any warranty for products sold or exported outside of the United States, its possessions and territories, except those sold through MTD’s authorized channels of export distribution.
- f. Replacement parts that are not genuine MTD parts.
- g. Transportation charges and service calls.

No implied warranty, including any implied warranty of merchantability of fitness for a particular purpose, applies after the applicable period of express written warranty above as to the parts as identified. No other express warranty, whether written or oral, except as mentioned above, given by any person or entity, including a dealer or retailer, with respect to any product, shall bind MTD. During the period of the warranty, the exclusive remedy is repair or replacement of the product as set forth above.

The provisions as set forth in this warranty provide the sole and exclusive remedy arising from the sale. MTD shall not be liable for incidental or consequential loss or damage including, without limitation, expenses incurred for substitute or replacement lawn care services or for rental expenses to temporarily replace a warranted product.

Some states do not allow the exclusion or limitation of incidental or consequential damages, or limitations on how long an implied warranty lasts, so the above exclusions or limitations may not apply to you.

In no event shall recovery of any kind be greater than the amount of the purchase price of the product sold. **Alteration of safety features of the product shall void this warranty.** You assume the risk and liability for loss, damage, or injury to you and your property and/or to others and their property arising out of the misuse or inability to use the product.

This limited warranty shall not extend to anyone other than the original purchaser or to the person for whom it was purchased as a gift.

HOW STATE LAW RELATES TO THIS WARRANTY: This limited warranty gives you specific legal rights, and you may also have other rights which vary from state to state.

IMPORTANT: Owner must present Original Proof of Purchase to obtain warranty coverage.

MTD LLC, P.O. BOX 361131 CLEVELAND, OHIO 44136-0019; Phone: 1-800-800-7310, 1-330-220-4683