

NordicTrack®

Classic Pro

Model No. NTXC80180

QUESTIONS?

As a manufacturer, we are committed to providing complete customer satisfaction. If you have questions, or if parts are missing or damaged, we will guarantee complete satisfaction through direct assistance from our factory.

TO AVOID UNNECESSARY DELAYS, PLEASE CALL DIRECT TO OUR TOLL-FREE CUSTOMER HOT LINE. The trained technicians on our customer hot line will provide immediate assistance, free of charge to you.

CUSTOMER HOT LINE:
1-888-825-2588
Mon.–Fri., 6 a.m.–6 p.m. MST

CAUTION

Read all precautions and instructions in this manual before using this equipment. Save this manual for future reference.

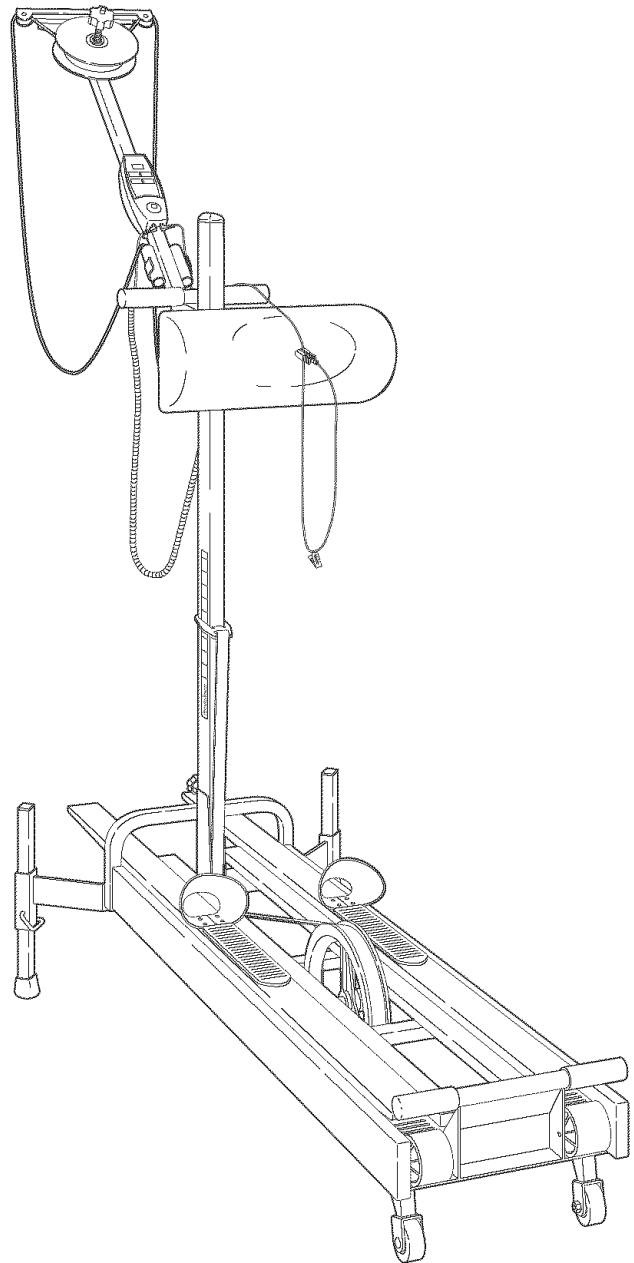

USER'S MANUAL

TABLE OF CONTENTS

IMPORTANT PRECAUTIONS	2
BEFORE YOU BEGIN	3
ASSEMBLY	4
HOW TO ADJUST THE SKI EXERCISER	6
HOW TO USE THE SKI EXERCISER	8
MAINTENANCE AND STORAGE	9
TROUBLE-SHOOTING	11
CONDITIONING GUIDELINES	13
PART LIST	14
EXPLODED DRAWING	15
HOW TO ORDER REPLACEMENT PARTS	.Back Cover
LIMITED WARRANTY	.Back Cover

IMPORTANT PRECAUTIONS

WARNING: To reduce the risk of serious injury, read all precautions and instructions in this manual before using the ski exerciser.

1. Read all instructions in this manual before using the ski exerciser. Use the ski exerciser only as described in this manual.
2. It is the responsibility of the owner to ensure that all users of the ski exerciser are adequately informed of all precautions.
3. Use the ski exerciser indoors, away from moisture and dust. Place the ski exerciser on a level surface, with a mat beneath it to protect the floor or carpet from damage.
4. Inspect and tighten all parts regularly. Replace any worn parts immediately.
5. Keep children under the age of 12 and pets away from the ski exerciser at all times.
6. The ski exerciser should not be used by persons weighing more than 250 pounds.
7. Wear appropriate clothing when exercising; do not wear loose clothing that could become caught on the ski exerciser. Always wear athletic shoes for foot protection.
8. The pulse monitor is not a medical device. Various factors, including the user's movement, may affect the accuracy of heart rate readings. The pulse monitor is intended only as an exercise aid in determining heart rate trends in general.
9. Keep hands and feet away from moving parts.
10. Always dismount the ski exerciser before adjusting the resistance of the ski pedals.
11. If you feel pain or dizziness at any time while exercising, stop immediately and begin cooling down.
12. This ski exerciser is intended for in-home use only. Do not use this ski exerciser in any commercial, rental, or institutional setting.

WARNING: Before beginning this or any exercise program, consult your physician. This is especially important for persons over the age of 35 or persons with pre-existing health problems. Read all instructions before using this product. ICON assumes no responsibility for personal injury or property damage sustained by or through the use of this product.

SAVE THESE INSTRUCTIONS

BEFORE YOU BEGIN

Thank you for selecting the innovative NordicTrack® CLASSIC PRO cross-country ski exerciser. Cross-country skiing is one of the most effective exercises for increasing cardiovascular fitness, building endurance, and toning the muscles. The NordicTrack® CLASSIC PRO cross-country ski exerciser features ultra-smooth skiing pedals, convenient upper-body arm cords, and adjustable resistance to let you enjoy this dynamic exercise in the convenience of your home.

For your benefit, read this manual carefully before you use the NordicTrack® CLASSIC PRO cross-

country ski exerciser. If you have questions after reading the manual, please call our Customer Service Department toll-free at 1-888-825-2588, Monday through Friday, 6 a.m. until 6 p.m. Mountain Time (excluding holidays). To help us assist you, please note the product model number before calling. The model number is NTXC80180.

Before reading further, please review the drawing below and familiarize yourself with the parts that are labeled.

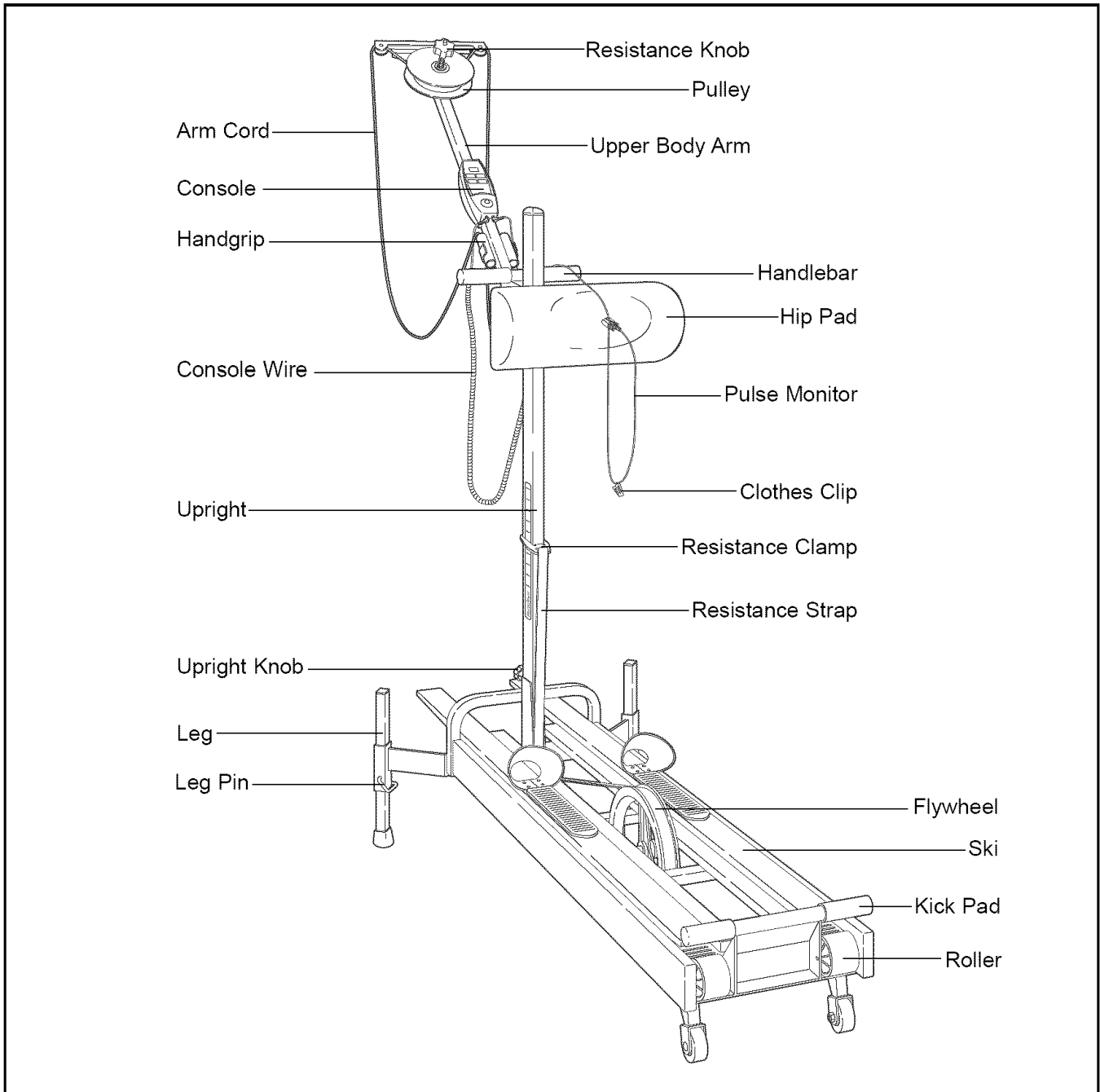

ASSEMBLY

Place all parts of the ski exerciser in a cleared area and remove the packing materials; do not dispose of the packing materials until assembly is completed. **Assembly requires only the included flat wrench tool.**

1. Align the holes in the Leg Bracket (2) with the holes in the Front Frame (1). The ends of the Leg Bracket should angle away from the Front Frame and the indicated hole should be positioned as shown.

Using the included flat wrench tool, attach the Leg Bracket (2) to the Front Frame (1) with two 3/8" x 5/8" Hex Screws (73) and two 3/8" Washers (72).

2. Slide a Leg (76) into the square opening in one end of either Leg Bracket (2). Align the second hole from the bottom of the Leg with the hole in the Leg Bracket.

Insert the straight end of a Leg Pin (74) completely through the holes in the Leg (76) and Leg Bracket (2). The bent end of the Leg Pin should point toward the floor as shown. **Make sure that the Leg Pin goes completely through the holes.** Rotate the bent end of the Leg Pin to secure it in place.

Attach the other Leg (76) in the same manner.

3. Lift the Upper Body Arm (27) slightly so it does not catch on the Front Frame (1) as you raise the Upright (16).

Lift the Upright (16) and lower it into the Front Frame (1). You will hear it snap into place when it is positioned correctly. Tighten the Upright Knob (17).

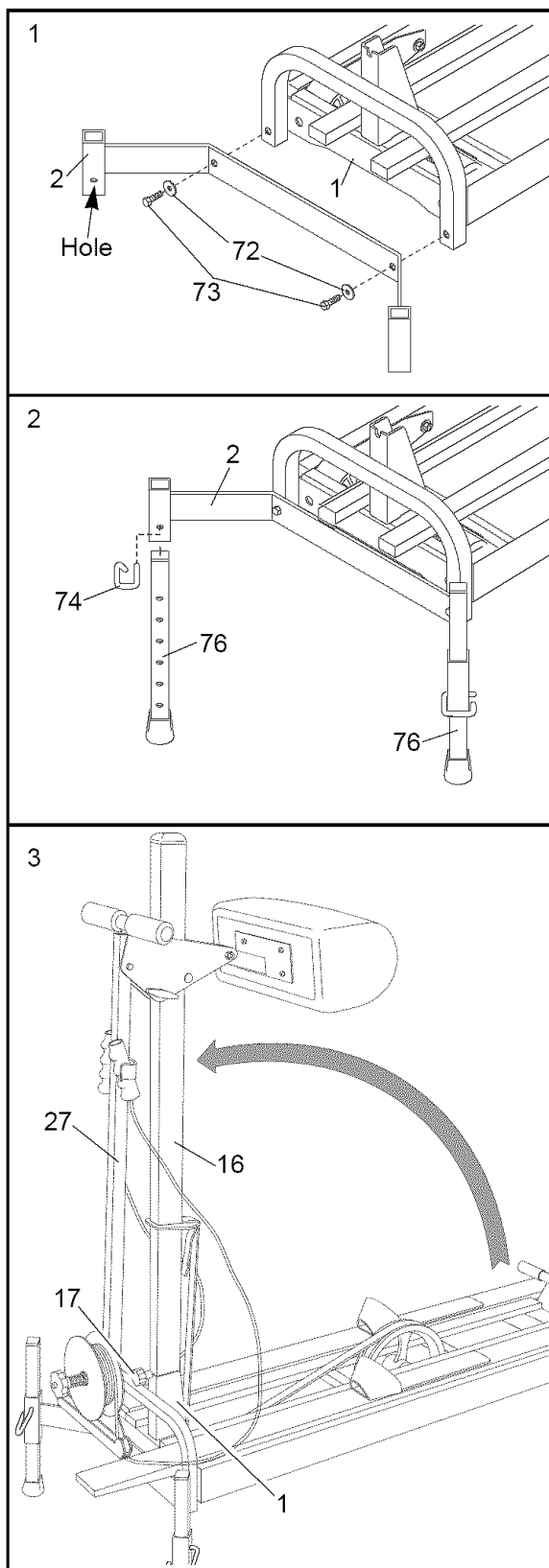

4. Lift the Upper body Arm (27) into position as shown. **Be sure the Snap Buttons (40) are fully extended and locked into position on both sides of the Hip Pad Slide (42).**

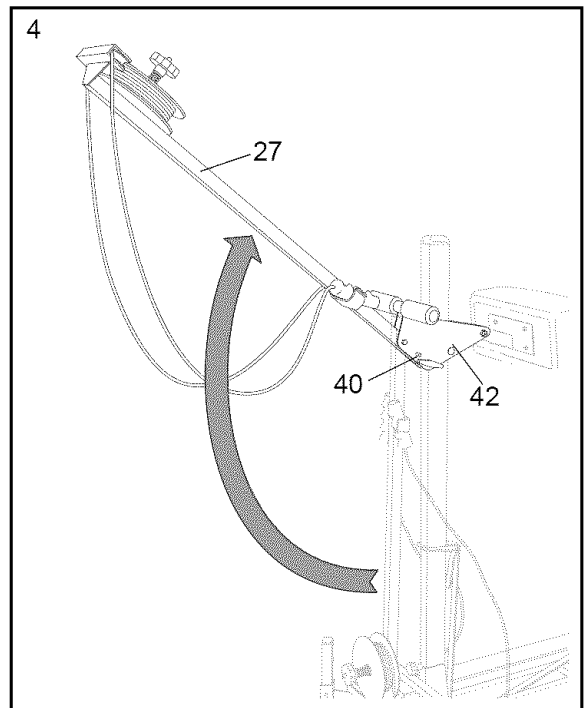

5. The Console (66) requires two “AA” batteries (not included). Alkaline batteries are recommended. Refer to the inset drawing. Locate the Battery Door (89) on the back of the Console. Slide the Battery Door to the left and open it as shown. Press two batteries into the battery compartment, **with the negative ends of the batteries touching the springs**. Close the Battery Door and slide it to the right.

Attach the Console (66) to the Upper Body Arm (27) by simply pressing it into place.

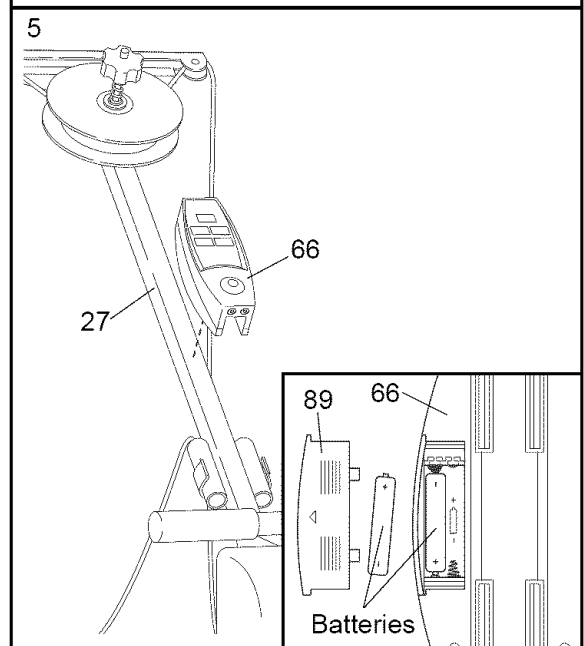

6. Plug the Console Wire (47) and the Pulse Monitor (49) into the jacks on the bottom of the Console (66) as shown.

Plug the Console Wire (47) into the jack on the Upright (16).

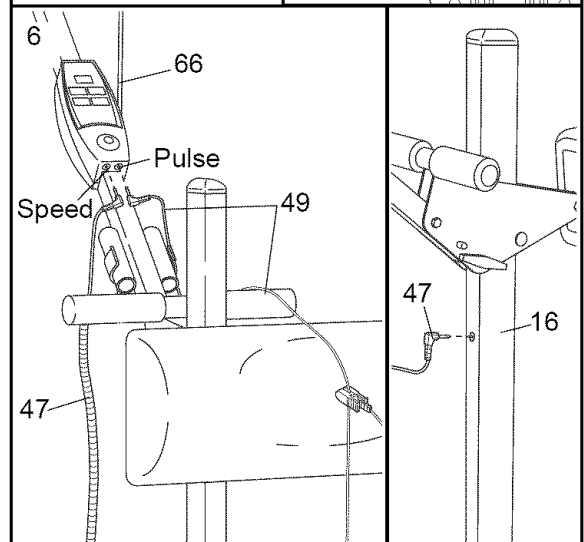

7. Make sure that all parts are tightened before you use the ski exerciser. To protect the floor from damage, place a mat beneath the ski exerciser.

HOW TO ADJUST THE SKI EXERCISER

HOW TO ADJUST THE RESISTANCE OF THE SKIS

To vary the intensity of your exercise, the amount of leg resistance can easily be adjusted by moving the resistance clamp on the upright. **CAUTION: Always dismount the ski exerciser before adjusting the resistance of the skis.**

To increase the resistance of the skis, raise the Resistance Clamp (85). Decrease the resistance by lowering the Resistance Clamp.

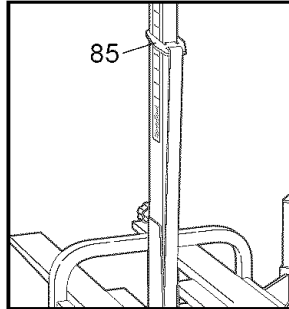

The intensity of your exercise can also be varied by using the arm cords (see the section below), or by changing the pace of your exercise.

HOW TO ADJUST THE ARM CORD RESISTANCE

The resistance of the Arm Cord (23) can be adjusted by turning the Resistance Knob (39) on top of the Pulley (35). Turn the Knob clockwise to increase the resistance. Turn the Knob counterclockwise to decrease the resistance.

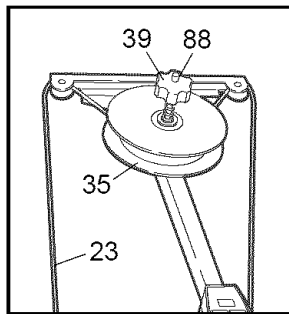

Note: As you turn the Resistance Knob to increase the resistance, the numbered Resistance Scale Decal (88) will protrude through the Knob to show the resistance settings.

CAUTION: The Pulley (35) will get hot during use. Avoid direct contact with the Pulley immediately after use.

ADJUST THE ARM CORD LENGTH

The proper Arm Cord (23) length should allow your arms to extend just beyond your hips.

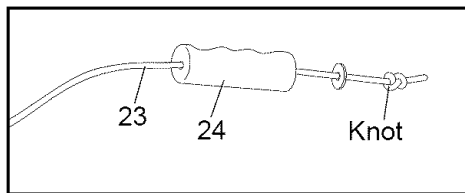

The arm cord length can be adjusted by retying the knots inside the Handgrips (24).

For greater adjustments in the cord length, one loop of the cord can be added to or removed from the pulley as shown at the right.

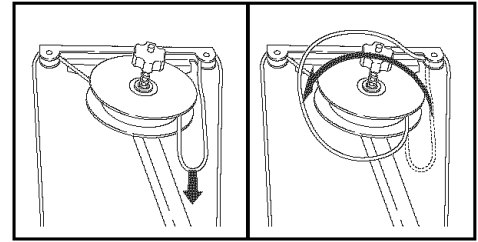

HOW TO ADJUST THE POSITION OF THE HIP PAD

Loosen the Adjustment Knobs (41) on each side of the Hip Pad Slide (42). Move the Hip Pad Slide to the desired position. The Hip Pad (53) should rest at hip level, about one inch below your navel. The Hip Pad should be high enough so it does not restrict leg movement and low enough so it does not press against your abdomen.

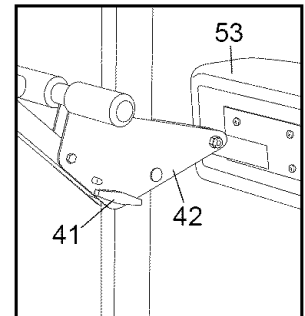

Tighten the Adjustment Knobs (41) to hold the Hip Pad (53) in position. Make sure both Knobs are secure.

HOW TO ADJUST THE ELEVATION OF THE SKI EXERCISER

Increasing the elevation and the leg resistance will simulate skiing uphill. This will further develop the quadriceps muscle group in the front of your thighs, elevate your heart rate more quickly and provide you with an even more intense workout.

You may select an elevation up to level ten. There is an increase of two degrees per hole.

To adjust the elevation, insert the straight end of a Leg Pin (74) completely through the holes in the Leg (76) and Leg Bracket (2). The bent end of the Leg Pin should point toward the floor as shown. **Make sure that the Leg Pin goes completely through the holes.** Rotate the bent end of the Leg Pin to secure it in place. Repeat this process on the other Leg (not shown).

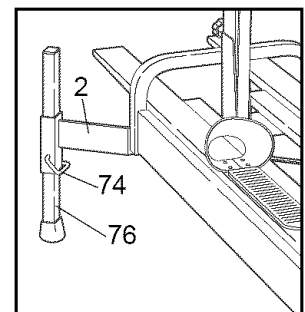

DESCRIPTION OF THE CONSOLE

The console has five independent displays to provide continuous exercise feedback. The displays are described below.

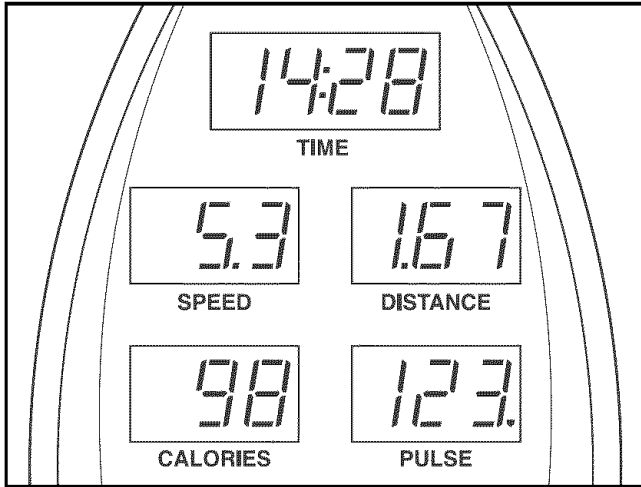

- Time—This mode displays the amount of time that you have exercised.
- Speed—This mode displays your pace, in miles per hour.
- Distance—This mode displays the total number of strides you have completed in miles per hour.
- Calories—This mode displays the approximate number of calories you have burned.
- Pulse—This mode displays your pulse in beats per minute when the pulse monitor is worn.

BATTERY INSTALLATION

Before the console can be operated, two “AA” batteries must be installed. If you have not installed batteries, see assembly step 5 on page 5.

HOW TO OPERATE THE CONSOLE

If there is a thin sheet of clear plastic on the face of the console, remove it.

1. To turn on the power, press the reset button or simply begin striding.

2. To use the pulse mode, the pulse monitor must be worn. Plug the pulse monitor into the jack on the bottom of the console. Rub your left ear lobe several times with your thumb and index finger and then clip the pulse monitor onto your ear lobe. Slide the metal clothes clip onto your collar.

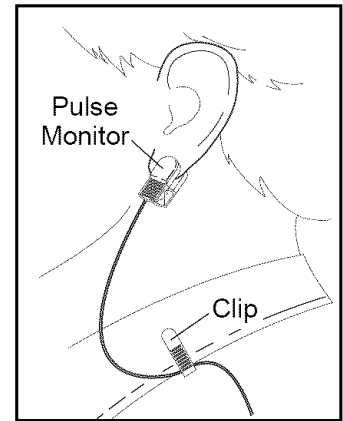

When your pulse is detected (after approximately four seconds), the small heart in the right-hand corner of the pulse display will flash and your pulse will be displayed. **WARNING: The pulse monitor is not a medical device. Various factors, including the user's movement, may affect the accuracy of heart rate readings. The pulse monitor is intended only as an exercise aid in determining heart rate trends in general.**

If your pulse does not appear after four seconds, make sure that the pulse monitor is plugged into the console. In addition, make sure that the pulse monitor is attached properly. It may be necessary to reposition the pulse monitor a few times to find the best position.

The pulse monitor is more accurate when used on your left ear lobe and when you are standing still.

3. To reset the display, press the reset button.

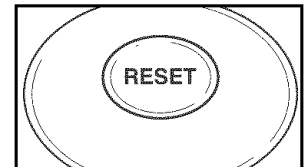

4. To turn off the power, simply wait for about five minutes. If the ski exerciser is not used and the console button is not pressed, the power will turn off automatically.

HOW TO USE THE SKI EXERCISER

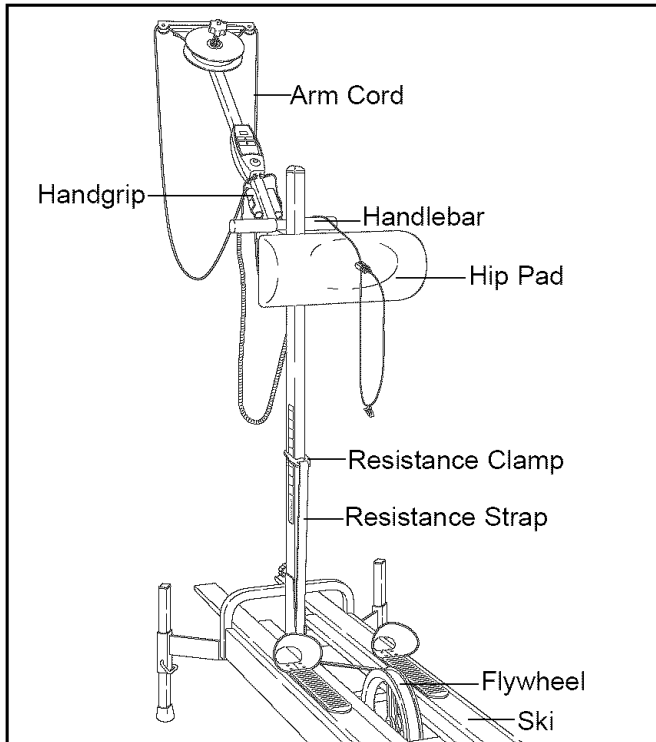

START WITH THE LEG MOTION ONLY

Note: See page 6 for steps 1, 2, and 3.

1. Set the leg resistance and adjust the elevation. Beginners may prefer to start with the ski exerciser in its lowest possible elevated position. **Note: Make sure the flywheel is not touching the floor.**
2. Adjust the hip pad to hip level. The hip pad should rest about one inch below your navel. It should be high enough that it does not restrict leg movement and low enough that it does not press against your abdomen. Make sure the hip pad adjustment knobs are tight; the hip pad is designed for you to push against. Do not lean over it. There may be some movement to the upright.
3. Hold the handlebars or hip pad for balance. Do not lean forward. Keep your weight on your feet and your back straight. **Increase the leg resistance if you slide away from the hip pad.**
4. Begin to ski. Push your right foot back, then your left; do not pull your right foot forward until the left is pushing back. **Do not bring either foot in front of your body.** Continue to move both feet in a smooth walking motion. Start with short, smooth strides. You will feel the leg resistance as you move your foot backward. Let your heel rise naturally at the back of your stride. Keep the balls of your feet on the skis at all times. Note: There is no defined

range of motion for your stride. Increase the leg resistance if you slide away from the hip pad. As you exercise, you may want to increase or decrease your stride depending on your comfort level. Once this motion feels comfortable, move on.

ADD ARM SWINGS TO THE LEG MOTION

1. Continue your leg motion. Keep one hand on the handlebar or the hip pad for balance. Swing the other arm at your side; when your left leg is forward, your left arm should swing back. Repeat this same process with your other hand.
2. Try swinging both arms when you are comfortable swinging each arm separately. Swing both arms naturally. A full arm swing motion allows your hands to extend just beyond your hips. Practice this motion until it feels comfortable.

COMBINE THE ARM AND LEG MOTIONS

1. Set the arm resistance to a comfortable level. Grasp the handgrips. Continue your leg motion.
2. Pull the handgrips through your natural arm swing. When your right leg is forward, your right hand should be back and when your left leg is forward, your left hand should be back. Practice this motion until it feels comfortable to you.

Below are some tips to help you coordinate the cross-country skiing motion:

1. If coordinating the arm and leg motion is difficult, concentrate on the leg motion only. Incorporate the arm motion once you feel comfortable with the leg motion. Do not bring your feet in front of your body until you are comfortable with the motion.
2. When you incorporate the arm motion, try to swing your arms naturally. Allow one arm to pull the other forward. Keep the arm cord taught.
3. Keep your waist in contact with the hip pad at all times to hold back your forward motion. If you feel like you are sliding away from the hip pad, increase the leg resistance.
4. Resistance is felt only as you push your feet backward, not as you pull forward. Always keep the weight of your body on the ski you are pushing backward. Avoid leaning forward. Keep your weight over your feet, your shoulders back and your head up. Find a focal point; this will help you keep your head up and your back straight.

MAINTENANCE AND STORAGE

Inspect and tighten all parts each time you use the ski exerciser.

CLEANING THE SKI EXERCISER

Wipe your ski exerciser with a clean, dry cloth after each workout to remove perspiration and dirt. Any household window cleaner may be used to clean the chrome and black metal surfaces after each use.

Wipe the wood with a clean, dry cloth to remove perspiration and dirt after each use. Use any wood furniture polish or wax to protect the wood finish and prevent drying.

The bottoms of the skis may become marked from contact with the drive rollers. Wipe them with a clean, dry cloth. Mineral spirits will lift stubborn marks. For a smooth glide while skiing, carefully rub paraffin wax only on the sides of the skis. **NEVER polish or wax the undersides of the skis.** The skid plates built into the sides of the skis are designed to wear down and leave a light coating on the sides of the wood. These plates do not need to be replaced.

LUBRICATION OF THE RESISTANCE PAD

The leather resistance pad on your arm exerciser has been oiled to allow for quiet, smooth braking action. However, the pad will require re-oiling if it dries due to its surroundings. We recommend inspecting the resistance pad every three months.

1. Place a cloth or a piece of plastic underneath the ski exerciser to protect your floor.

2. See the inset drawing. Inspect the Thrust Washer (37). Lightly oil the Thrust Washer if it is not greasy.

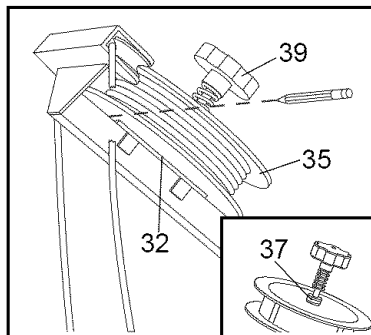

Fully loosen but do not remove the Resistance Knob (39). Lift the Pulley (35) and roughen the surface of the leather Resistance Pad (32) with 100-grit sandpaper or a file.

3. Spread one or two drops of light household oil on the Resistance Pad. **DO NOT OVER-OIL!** Excess oil may spray out when the Pulley is spinning. Place a pencil between the Pulley and the Resistance Pad and let the oil absorb overnight.

4. Wipe any excess oil away from the area around the Resistance Pad. Tighten the Resistance Knob.

Inspect the bottom of the Pulley. If the resistance disk (located above the Resistance Pad) has grooves worn into it, it may be necessary to replace it. See the back of this manual for instructions on how to order replacement parts.

CARE FOR THE RESISTANCE STRAP AND FLYWHEEL

Resistance strap and flywheel maintenance should be performed once a month at the same time. Follow the steps below.

1. Place a cloth or a piece of plastic underneath the ski exerciser to protect your floor.

2. Set the ski resistance to the lowest setting.

3. Slide the resistance strap off the side of the flywheel.

4. Wipe the surface of the flywheel with a clean cloth dampened with rubbing alcohol.

5. Check the groove of the flywheel for any rust or corrosion.

6. Use fine to very fine steel wool to spot rub any rust or corrosion. Clean the entire flywheel with steel wool if necessary.

7. Wipe the flywheel with a clean, dry cloth to remove any residue. **NEVER place oil between the resistance strap and flywheel.** This will damage the resistance strap.

8. Slide the "U" Bolt Cover (64) to the right to check the tightness of the 1/4" Nuts (67) on the right side of the Flywheel (54). Tighten the Nuts evenly with a

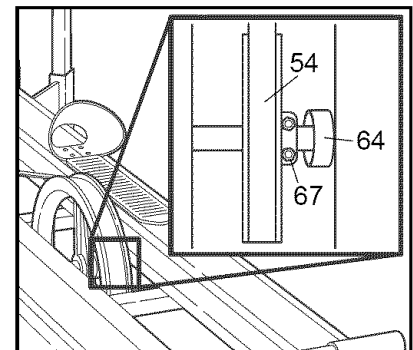

wrench if necessary. **CAUTION: Do not overtighten the 1/4" Nuts; this can break the "U" Bolt.**

- Slide the resistance strap back onto the flywheel.
Note: If the resistance strap is frayed on both sides, it may be necessary to replace it. See the back cover of this manual for information on how to order replacement parts.

GENERAL LUBRICATION

If the front and rear Rollers (15) begin to squeak, a drop of light household oil may occasionally be needed on the Roller Axles (70). However, the drive rollers located near the flywheel are internally lubricated and **should NOT be oiled**. Follow the instructions below to apply the oil.

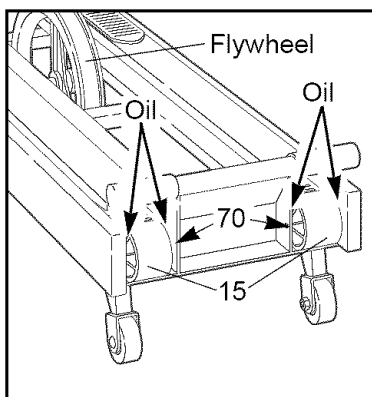

- Place a cloth or a piece of plastic underneath the ski exerciser to protect your floor.
- Put a drop of light household oil on each side of each roller, and then spin each roller.

STORAGE

Loosen the resistance completely and remove any accessories before folding and storing your ski exerciser. For long term storage of more than 30 days we recommend the following:

- Remove the batteries from the console.
- Slide the resistance strap off the flywheel.
- Lightly coat the groove of the flywheel with a light household oil to protect the metal from corrosion.
IMPORTANT: Never place oil on the resistance strap. Only the flywheel should be oiled and then cleaned before the resistance strap is reattached. Do not place the resistance strap onto the oiled flywheel.
- Loosen the two adjustment knobs on the hip pad.
- Move the hip pad slide so the tip is about seven inches below the top of the upright. Retighten both the adjustment knobs and pivot the hip pad upward.
- Support the upper body arm with one hand. Use the other hand to depress the two snap buttons on either side of the arm. Lower the upper body arm until it rests against the upright.
- Hold the upright with one hand. Loosen and remove the upright knob from the upright. Lower the upright until it rests on the base. The hip pad should just touch the top of the skis.

Upon removal from storage, clean the flywheel with rubbing alcohol. Slide the resistance strap back onto the flywheel.

To move the ski exerciser, use the handlebar to pull it back on its wheels and roll it to the desired location.

TROUBLE-SHOOTING

Most ski exerciser problems can be solved by following the steps below. Find the problem that applies, and follow the steps listed. If further assistance is needed, please call our Customer Service Department.

PROBLEM: The console does not function properly.

SOLUTION: a. Make sure the console wire is fully plugged in on both ends (see step 6 on page 5).

b. If the console does not function properly, or if the display becomes faint, the batteries should be replaced. See assembly step 5 on page 5 for installation instructions.

PROBLEM: The arm cords are tangled.

CAUTION: The pulley will get hot during use. Avoid direct contact with the pulley immediately after use.

SOLUTION: a. Detach the handgrips by untying the knot and removing the 1/4" washer inside the handgrips (see page 6). Take the Arm Cord (23) out of the Small Pulleys (28) and unwind it from the Pulley (35). Notice how it goes into the Pulley. Drape both ends of the Arm Cord over the hip pad. Make sure the ends of the Arm Cords are even.

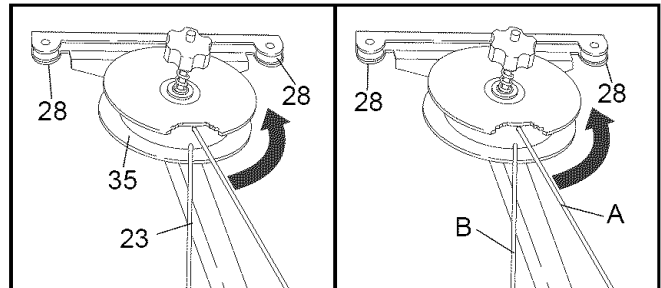

b. Locate cord "A." Wrap it counterclockwise around the Pulley until you have no more Arm Cord to wind. Do not be concerned if it looks tangled; it will smooth out later.

c. Pass the end of cord "A" from left to right through the right Small Pulley (28). Pull cord "A" to wrap the other section of the Arm Cord (cord "B") around the Pulley.

d. Feed the end of cord "B" from right to left through the left Small Pulley (28). Pull cord "B" until the end of the Arm Cord is even with cord "A." With an Arm Cord end in each hand, work the arm exerciser back and forth until the Arm Cord lies smoothly.

e. To reattach each handgrip, thread the arm cord through the hole in the handgrip from top to inside. Slip a 1/4" washer onto the arm cord and tie a figure-eight knot as shown at the right near the arm cord end.

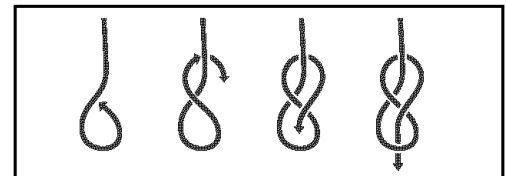

Note: The arm cord length can be adjusted by retying the knots inside the handgrips. For greater adjustments in the cord length, one loop of cord can be added to or removed from the pulley. See page 6. Proper arm cord length allows your arms to extend just beyond your hips.

PROBLEM: The arm cord assembly is chattering or making a screeching sound or the arm resistance knob loosens.

SOLUTION: a. Check the order of the pulley assembly. Confirm that all parts are present. The assembly from the pulley to the knob should be as follows: 3/8" washer, thrust washer, 3/8" washer, spring and resistance knob.

- b. Roughen the surface of the resistance pad with 100-grit sandpaper. Oil the leather resistance pad with one or two drops of light household oil. Spread the oil over the resistance pad.
- c. Oil the 3/8" washers and the thrust washer if needed.

PROBLEM: The flywheel and/or the resistance strap offers no resistance.

SOLUTION: a. Check the routing of the resistance strap.

- b. Make sure the flywheel is tight. Remove the "U" bolt cover from the flywheel (see page 9). Evenly tighten the two 1/4" nuts located on the right side of the flywheel.

PROBLEM: The skis are slipping.

SOLUTION: a. Wipe off any excess oil.

- b. Clean the bottom of the skis with a dry cloth or a small amount of mineral spirits or paint thinner.
- c. Make sure that the flywheel is tight. Remove the "U" bolt cover from the flywheel (see page 9). Evenly tighten the two 1/4" nuts located on the right side of the flywheel.

PROBLEM: The rollers are squeaking or sticking.

SOLUTION: See GENERAL LUBRICATION on page 10.

CONDITIONING GUIDELINES

The following guidelines will help you to plan your exercise program. Remember that proper nutrition and adequate rest are essential for successful results.

WARNING: Before beginning this or any exercise program, consult your physician. This is especially important for individuals over the age of 35 or individuals with pre-existing health problems.

EXERCISE INTENSITY

Whether your goal is to burn fat or to strengthen your cardiovascular system, the key to achieving the desired results is to exercise with the proper intensity. The proper intensity level can be found by using your heart rate as a guide. The chart below shows recommended heart rates for fat burning, maximum fat burning, and cardiovascular (aerobic) exercise.

20	30	40	50	60	70	80	AGE
165							
145	155						
125	138	145	140				
	120	130	125	130	125		
		115	110	118	110	115	AEROBIC
				105	110	105	MAX. FAT
					95	90	FAT BURN
							b.p.m.

To find the proper heart rate for you, first find your age at the top of the chart (ages are rounded off to the nearest ten years). Next, find the three numbers below your age. The three numbers are your “training zone.” The lowest number is the recommended heart rate for fat burning; the middle number is the heart rate for maximum fat burning; and the highest number is the heart rate for aerobic exercise.

Burning Fat

To burn fat effectively, you must exercise at a relatively low intensity level for a sustained period of time. During the first few minutes of exercise, your body uses easily accessible *carbohydrate* calories for energy. Only after the first few minutes of exercise does your body begin to use stored *fat* calories for energy. If your goal is to burn fat, adjust the intensity of your exercise until your heart rate is near the lowest number in your training zone as you exercise.

For maximum fat burning, adjust the intensity of your exercise until your heart rate is near the middle number in your training zone as you exercise.

Aerobic Exercise

If your goal is to strengthen your cardiovascular system, your exercise must be “aerobic.” Aerobic exercise is activity that requires large amounts of oxygen for prolonged periods of time. This increases the demand on the heart to pump blood to the muscles, and on the lungs to oxygenate the blood. For aerobic exercise, adjust the intensity of your exercise until your heart rate is near the highest number in your training zone.

WORKOUT GUIDELINES

Each workout should include three important parts: a warm-up, training zone exercise, and a cool-down.

Warming up—Begin each workout with 5 to 10 minutes of stretching and light exercise. A proper warm-up increases your body temperature, heart rate and circulation in preparation for exercise.

Training zone exercise—After warming up, increase the intensity of your exercise until your heart rate is in your training zone for 20 to 30 minutes. (During the first few weeks of your exercise program, do not keep your heart rate in your training zone for longer than 20 minutes.)

Cooling down—Finish each workout with 5 to 10 minutes of stretching. This will increase your flexibility and will help to prevent post-exercise problems.

EXERCISE FREQUENCY

To maintain or improve your condition, plan three workouts each week, with at least one day of rest between workouts. Five minutes of exercise, four times a day, may be sufficient when you begin an exercise program. Slowly increase your workout time as your fitness level improves. After a few months of regular exercise, you may complete up to five workouts each week, if desired. Find the best time of day for your workouts, and then stick with it.

Remember, the key to success is to make exercise a regular and enjoyable part of your everyday life.

PART LIST—MODEL NO. NTXC80180

R0499A

Key No.	Qty.	Description	Key No.	Qty.	Description	Key No.	Qty.	Description
1	1	Front Frame	32	1	Resistance Pad	63	1	Axle Clamp w/Set Screw
2	1	Leg Bracket	33	4	#6 x .62" Screw	64	1	"U" Bolt Cover
3	1	Rear Frame	34	1	Resistance Disc	65	1	1/4" "U" Bolt
4	1	Left Side Board	35	1	Pulley	66	1	Console
5	1	Right Side Board	36	2	3/8" Washer	67	2	1/4" Nut
6	2	Cross Member	37	1	Thrust Washer	68	8	#12 x .55" Screw
7	2	Top Board	38	1	Spring	69	4	Small Nylon Spacer
8	2	Ski	39	1	Resistance Knob	70	4	Roller Axle
9	2	Foot Plate	40	1	Snap Buttons	71	2	Self-Backing Nut
10	2	Toe Piece	41	2	Adjustment Knob	72	2	3/8" Washer
11	4	Skid Plate	42	1	Hip Pad Slide	73	2	3/8" x 5/8" Hex Screw
12	8	#10 x 5/8" Screw	43	2	Round Endcap	74	2	Leg Pin
13	4	#10 x 1.25" Screw	44	2	5/16" x 1.75" Carriage Bolt	75	2	Square Endcap
14	2	Kick Pad	45	2	1/4" Jam Nut	76	2	Leg
15	4	Roller	46	2	1/4" x 1.5" Bolt	77	2	Rubber Foot
16	1	Upright	47	1	Console Wire	78	1	5/16" x 2" Hex Head Bolt
17	1	Upright Knob	48	4	#12 x 1" Screw	79	9	5/16" Flange Nut
18	1	5/16" Push Nut	49	1	Pulse Monitor	80	8	5/16" x 1.25" Carriage Bolt
19	1	5/16" x 2.75" Carriage Bolt	50	2	Bumper	81	2	Wheel
20	1	Reed Switch/Wire	51	1	Pad Bracket	82	2	1/4" x 1.5" Carriage Bolt
21	1	Reed Switch Bracket	52	1	Pad Cover	83	2	1/4" Hex Nut
22	1	#8 x .62" Screw	53	1	Hip Pad	84	1	Resistance Strap
23	1	Arm Cord	54	1	Flywheel	85	1	Resistance Clamp
24	2	Handgrip	55	1	Flywheel Axle	86	1	Resistance Spring
25	4	1/4" Washer	56	2	Flywheel Bearing	87	2	Foam Grip
26	1	Upright Endcap	57	1	Magnet Bracket	88	1	Resistance Scale Decal
27	1	Upper Body Arm	58	1	Magnet	89	1	Battery Door
28	2	Small Pulley	59	4	.64" x 1.19" Washer	90	2	Bronze Bushing
29	4	"C" Clip	60	4	Large Nylon Spacer	91	1	#10 x 1/2" Screw
30	2	Pulley Axle	61	2	Drive Roller w/Bearing	#	1	Flat Wrench Tool
31	2	Resistance Bracket	62	1	#10 Set Screw	#	1	User's Manual

Note: "#" indicates a non-illustrated part. Specifications are subject to change without notice. See the back cover of this manual for information about ordering replacement parts.

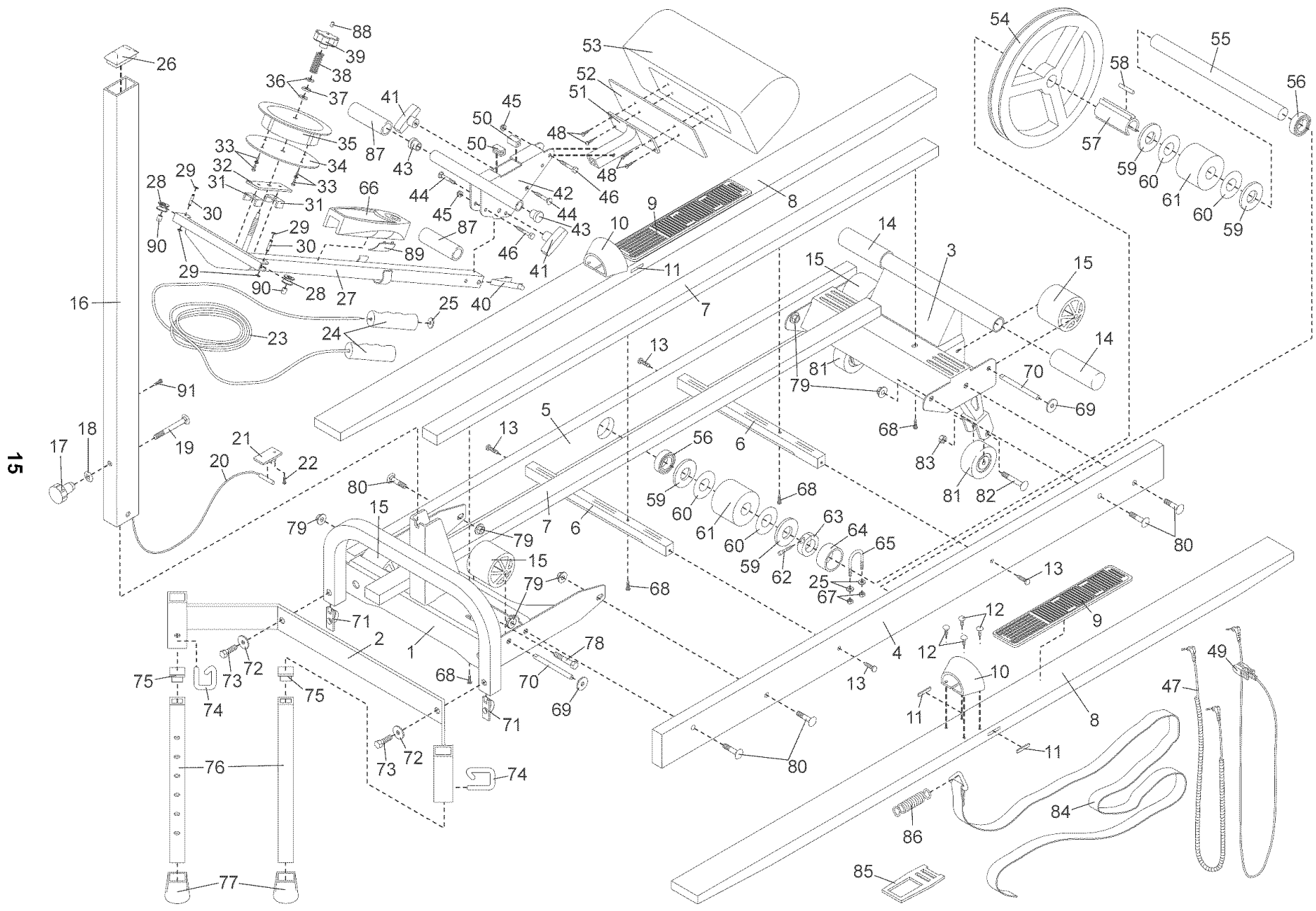

EXPLODED DRAWING—MODEL NO. NTXC80180

R0499A

HOW TO ORDER REPLACEMENT PARTS

To order replacement parts, call our Customer Service Department toll-free at 1-888-825-2588, Monday through Friday, 6 a.m. until 6 p.m. Mountain Time (excluding holidays). Please mention the following information when calling.

- The MODEL NUMBER of the product (NTXC80180).
- The NAME of the product (NordicTrack® CLASSIC PRO cross-country ski exerciser).
- The KEY NUMBER and DESCRIPTION of the part(s) from page 14 of this manual.

LIMITED WARRANTY

WHAT IS COVERED—The entire NordicTrack® CLASSIC PRO cross-country ski exerciser ("Product") is warranted to be free of all defects in material and workmanship.

WHO IS COVERED—The original purchaser or any person receiving the Product as a gift from the original purchaser.

HOW LONG IS IT COVERED—ICON Health & Fitness, Inc. ("ICON"), warrants the product for one year after the date of purchase. Labor is covered for one year.

WHAT WE DO TO CORRECT COVERED DEFECTS—We will ship to you, without charge, any replacement part or component, providing the repairs are authorized by ICON first and are performed by an ICON trained and authorized service provider, or, at our option, we will replace the Product.

WHAT IS NOT COVERED—Any failures or damage caused by unauthorized service, misuse, accident, negligence, improper assembly or installation, alterations, modifications without our written authorization or by failure on your part to use, operate, and maintain as set out in your User's Manual ("Manual").

WHAT YOU MUST DO—Always retain proof of purchase, such as your bill of sale; store, operate, and maintain the Product as specified in the Manual; notify our Customer Service Department of any defect within 10 days after discovery of the defect; as instructed, return any defected part for replacement or, if necessary, the entire product, for repair.

USER'S MANUAL—It is VERY IMPORTANT THAT YOU READ THE MANUAL before operating the Product. Remember to do the periodic maintenance requirements specified in the Manual to assure proper operation and your continued satisfaction.

HOW TO GET PARTS AND SERVICE—Simply call our Customer Service Department at 1-888-825-2588 and tell them your name and address and the serial number of your Product. They will tell you how to get a part replaced, or if necessary, arrange for service where your Product is located or advise you how to ship the Product for service. Before shipping, always obtain a Return Authorization Number (RA No.) from our Customer Service Department; securely pack your Product (save the original shipping carton if possible); put the RA No. on the outside of the carton and insure the product. Include a letter explaining the product or problem and a copy of your proof of purchase if you believe the service is covered by warranty.

ICON is not responsible or liable for indirect, special or consequential damages arising out of or in connection with the use or performance of the product or damages with respect to any economic loss, loss of property, loss of revenues or profits, loss of enjoyment or use, costs of removal, installation or other consequential damages of whatsoever nature. Some states do not allow the exclusion or limitation of incidental or consequential damages. Accordingly, the above limitation may not apply to you.

The warranty extended hereunder is in lieu of any and all other warranties and any implied warranties of merchantability or fitness for a particular purpose is limited in its scope and duration to the terms set forth herein. Some states do not allow limitations on how long an implied warranty lasts. Accordingly, the above limitation may not apply to you.

No one is authorized to change, modify or extend the terms of this limited warranty. This warranty gives you specific legal rights and you may have other rights which vary from state to state.

ICON HEALTH & FITNESS, INC., 1500 S. 1000 W., LOGAN, UT 84321-9813