



# PRO-FORM<sup>®</sup>

## CardioCrossTrainer 800

Model No. PFEL39030

Serial No. \_\_\_\_\_

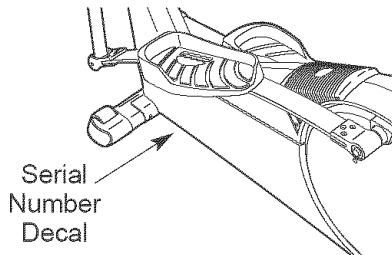

## USER'S MANUAL

### QUESTIONS?

If you have questions, or if there are missing parts, we will guarantee complete satisfaction through direct assistance from our factory.

TO AVOID DELAYS, PLEASE CALL DIRECT TO OUR TOLL-FREE CUSTOMER HOT LINE. The trained technicians on our customer hot line will provide immediate assistance, free of charge to you.

CUSTOMER HOT LINE:

**1-800-999-3756**

Mon.-Fri., 6 a.m.-6 p.m. MST

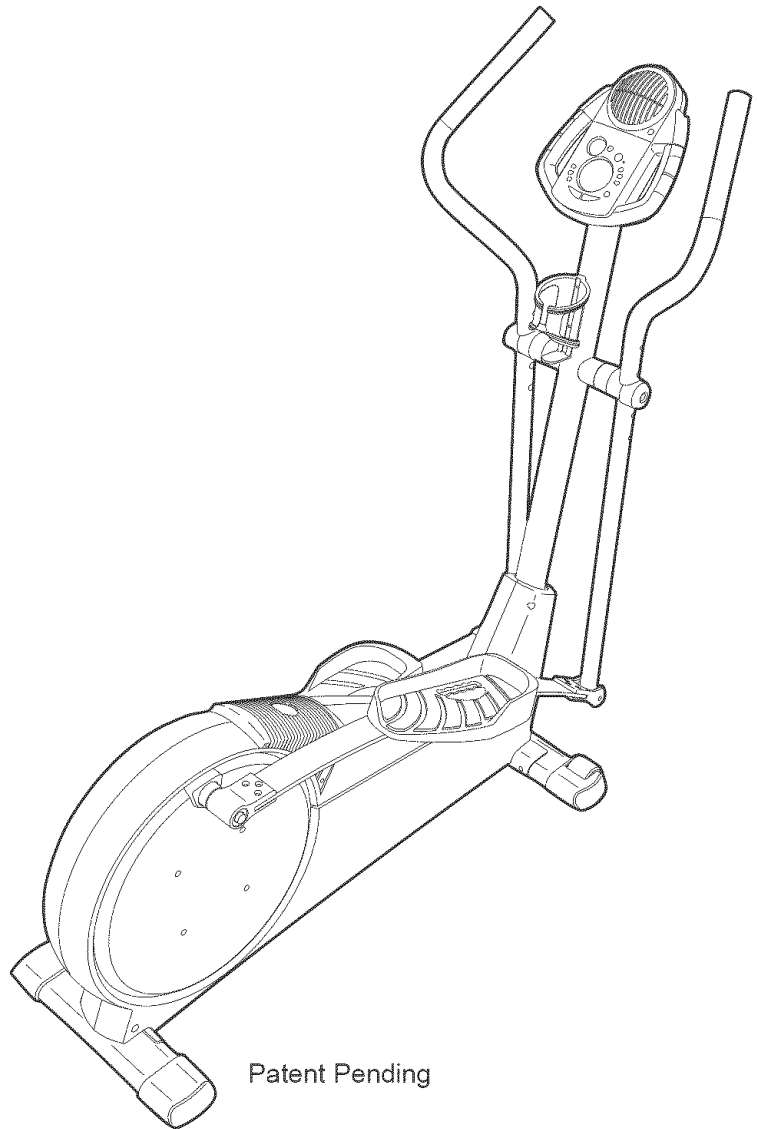

Patent Pending

### ▲ CAUTION

Read all precautions and instructions in this manual before using this equipment. Keep this manual for future reference.



Visit our website at

[www.proform.com](http://www.proform.com)

new products, prizes,  
fitness tips, and much more!



---

## TABLE OF CONTENTS

IMPORTANT PRECAUTIONS .....	3
BEFORE YOU BEGIN .....	4
ASSEMBLY .....	5
HOW TO USE THE ELLIPTICAL CROSSTRAINER .....	9
MAINTENANCE AND TROUBLESHOOTING .....	19
CONDITIONING GUIDELINES .....	20
PART LIST .....	22
EXPLODED DRAWING .....	23
HOW TO ORDER REPLACEMENT PARTS .....	.Back Cover
LIMITED WARRANTY .....	.Back Cover

# IMPORTANT PRECAUTIONS

**⚠ WARNING:** To reduce the risk of serious injury, read the following important precautions before using the elliptical crosstrainer.

1. Read all instructions in this manual before using the elliptical crosstrainer.
2. It is the responsibility of the owner to ensure that all users of the elliptical crosstrainer are adequately informed of all precautions.
3. The elliptical crosstrainer is intended for home use only. Do not use the elliptical crosstrainer in a commercial, rental, or institutional setting.
4. Place the elliptical crosstrainer on a level surface, with a mat beneath it to protect the floor or carpet. Keep the elliptical crosstrainer indoors, away from moisture and dust.
5. Inspect and properly tighten all parts regularly. Replace any worn parts immediately.
6. Keep children under 12 and pets away from the elliptical crosstrainer at all times.
7. The elliptical crosstrainer should not be used by persons weighing more than 250 pounds.
8. Wear appropriate exercise clothes when using the elliptical crosstrainer. Always wear athletic shoes for foot protection while exercising.
9. Hold the handgrip pulse sensor or the handlebars when mounting, dismounting, or using the elliptical crosstrainer.
10. The pulse sensor is not a medical device. Various factors may affect the accuracy of heart rate readings. The pulse sensor is intended only as an exercise aid in determining heart rate trends in general.
11. Keep your back straight when using the elliptical crosstrainer; do not arch your back.
12. If you feel pain or dizziness while exercising, stop immediately and begin cooling down.
13. When you stop exercising, allow the pedals to slowly come to a stop.
14. The decal shown below has been placed on the elliptical crosstrainer. If the decal is missing, or if it is not legible, please call our Customer Service Department toll-free at 1-800-999-3756 to order a free replacement decal. Apply the decal in the location shown.

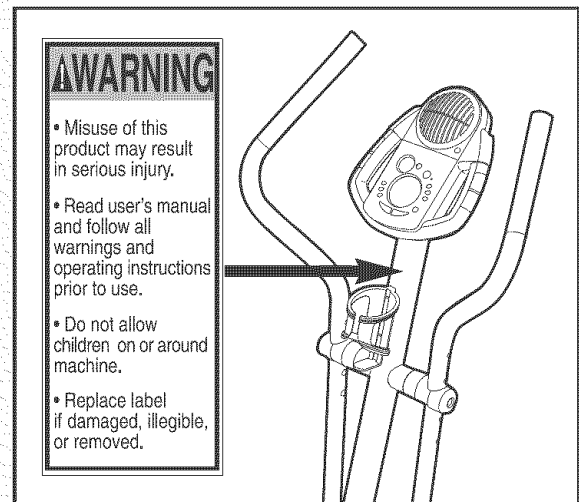

**⚠ WARNING:** Before beginning this or any exercise program, consult your physician. This is especially important for persons over the age of 35 or persons with pre-existing health problems. Read all instructions before using. ICON assumes no responsibility for personal injury or property damage sustained by or through the use of this product.

# BEFORE YOU BEGIN

Congratulations for selecting the new PROFORM® 800 CARDIO CROSSTRAINER. The PROFORM® 800 is an incredibly smooth exerciser that moves your feet in a natural elliptical path, minimizing the impact on your knees and ankles. And the unique PROFORM® 800 features adjustable resistance and a state-of-the-art console to help you get the most from your exercise. Welcome to a whole new world of natural, elliptical-motion exercise from PROFORM.



questions after reading this manual, call our Customer Service Department toll-free at 1-800-999-3756, Monday through Friday, 6 a.m. until 6 p.m. Mountain Time (excluding holidays). To help us assist you, please note the product model number and serial number before calling. The model number is PFEL39030. The serial number can be found on a decal attached to the elliptical crosstrainer (see the front cover of this manual for the location of the decal).

**For your benefit, read this manual carefully before you use the elliptical crosstrainer.** If you have

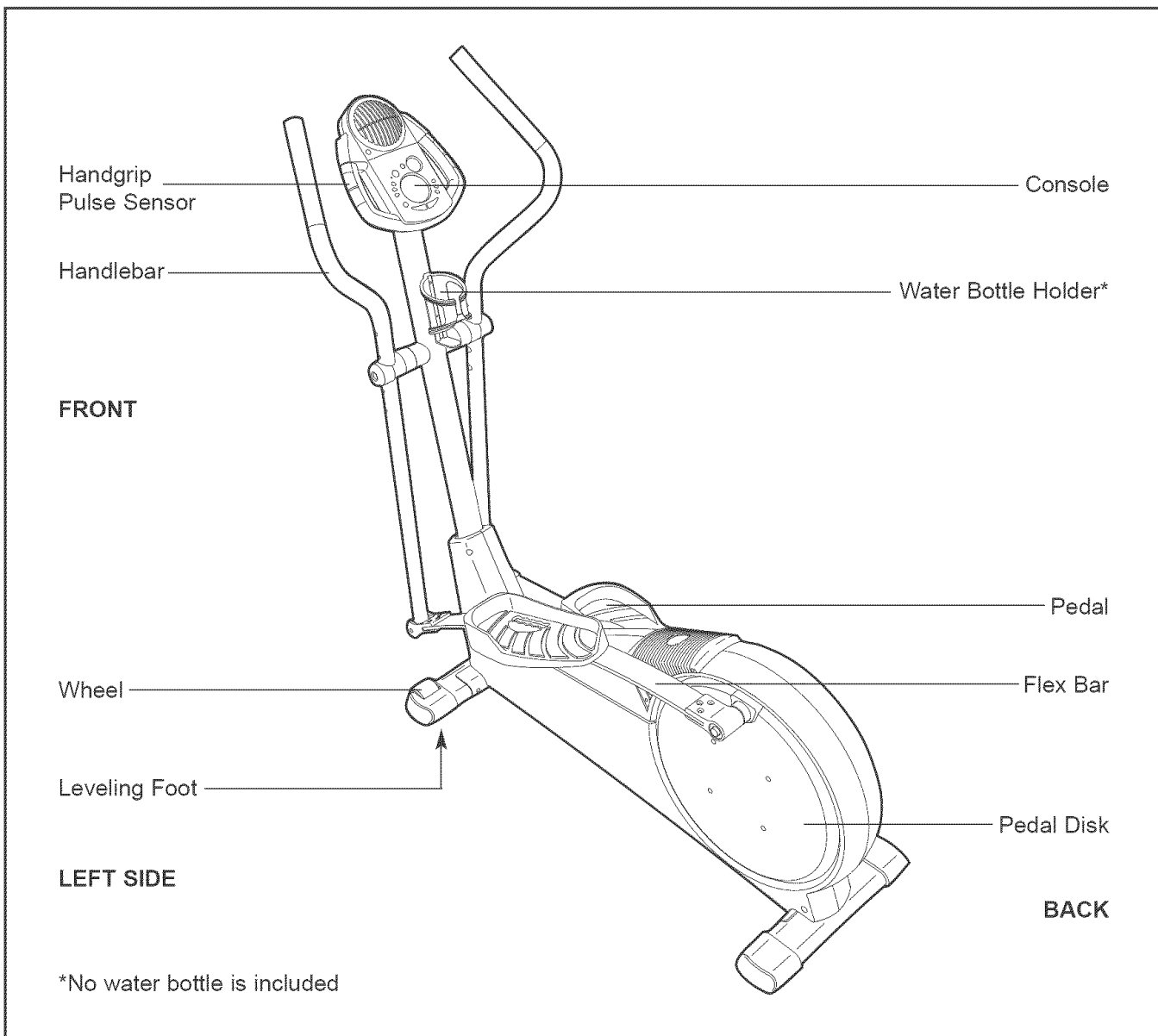



Before reading further, please familiarize yourself with the parts that are labeled in the drawing below.



# ASSEMBLY

Assembly requires two persons. Place all parts of the elliptical crosstrainer in a cleared area and remove the packing materials. Do not dispose of the packing materials until assembly is completed. **In addition to the included allen wrenches, assembly requires a phillips screwdriver** , **an adjustable wrench** , and **a rubber mallet** .

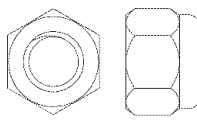
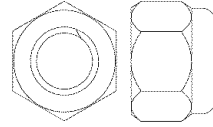
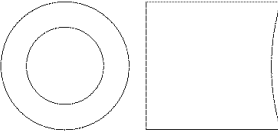
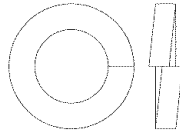
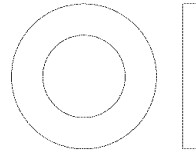
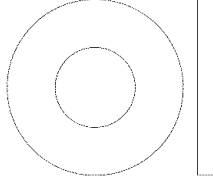
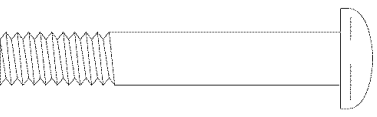
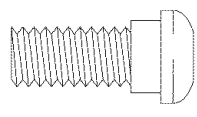
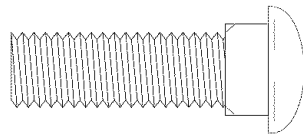
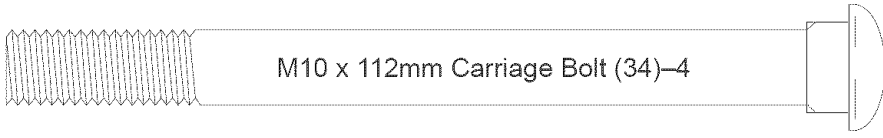
As you assemble the elliptical crosstrainer, use the drawings below to identify the small parts used in assembly. The number in parenthesis below each drawing refers to the key number of the part, from the PART LIST on page 22. The second number refers to the quantity needed for assembly. **Note: Some small parts may have been pre-assembled. If a part is not in the parts bag, check to see if it has been pre-assembled.**

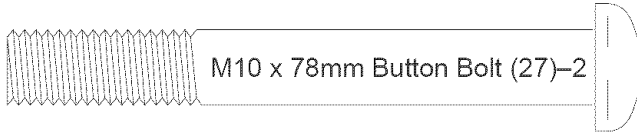
			
M4 x 16mm Screw (66)-4	M4 x 22mm Screw (93)-2	M8 Nylon Locknut (46)-4	M10 Nylon Locknut (29)-6
			
Frame Spacer (83)-1	M10 Split Washer (70)-1	M10.3 Black Washer (53)-2	M10 Washer (38)-6
			
M8 x 45mm Button Bolt (50)-4	M8 x 19mm Shoulder Screw (22)-2	M10 x 33mm Carriage Bolt (20)-2	
			
M10 x 112mm Carriage Bolt (34)-4			
			
M10 x 88mm Button Screw (63)-1			
			
M10 x 78mm Button Bolt (27)-2			

1. Identify the Front Stabilizer (3). While another person lifts the front of the Frame (1), attach the Front Stabilizer to the Frame with two M10 x 112mm Carriage Bolts (34) and two M10 Nylon Locknuts (29). **Make sure that the Front Stabilizer is turned so the Wheels (32) are not touching the floor.**

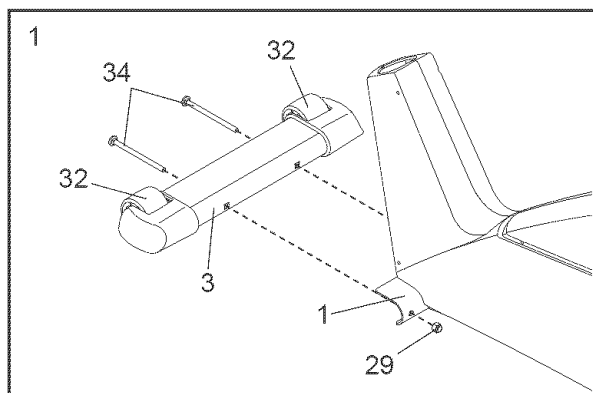

2. While another person lifts the back of the Frame (1), attach the Rear Stabilizer (4) to the Frame with two M10 x 112mm Carriage Bolts (34) and two M10 Nylon Locknuts (29).

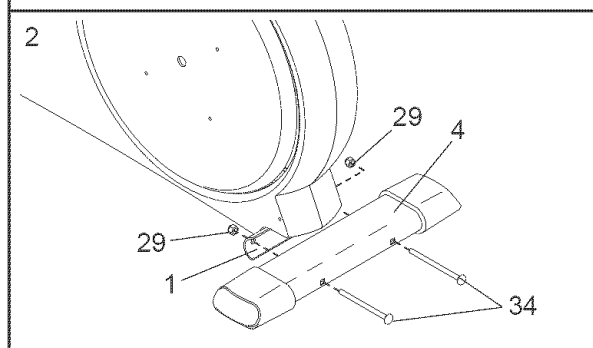

3. While another person holds the Upright (2) in the position shown, connect the Upper Wire Harness (86) to the Lower Wire Harness (87). **Carefully pull the upper end of the Upper Wire Harness to remove any slack. While holding the upper end of the Upper Wire Harness, insert the Upright into the Frame (1). Do not pinch the Wire Harnesses.**

Slide an M10 Split Washer (70) and a Frame Spacer (83) onto an M10 x 88mm Button Bolt (63). Insert the Button Bolt into the Frame (1) and the Upright (2).

**Make sure that the concave end of the Frame Spacer is turned toward the Frame. Do not tighten the Button Bolt yet.**

Attach the Water Bottle Holder (91) to the Upright (2) with two M4 x 22mm Screws (93).

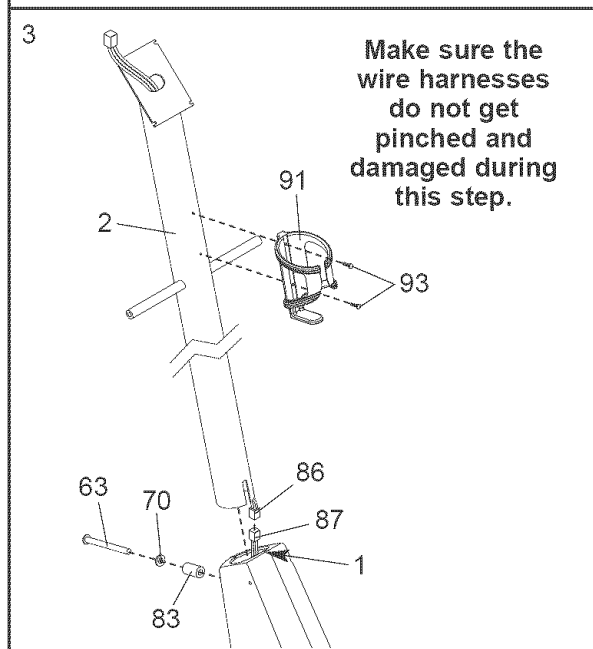

4. While another person holds the Console (5) in the position shown, connect the wire harness on the Console to the Upper Wire Harness (86). Insert the excess wire harness into the Upright (2). Next, attach the Console to the Upright with four M4 x 16mm Screws (66). **Be careful to avoid pinching the wire harnesses.**

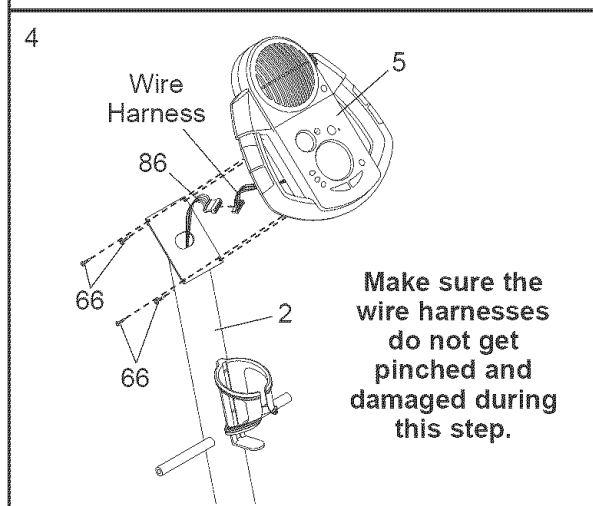

5. The Console (5) requires four “D” batteries (not included); alkaline batteries are recommended. Pull the battery drawer open. Insert four batteries into the battery drawer. **Make sure that the batteries are oriented as shown by the diagram inside the battery drawer.** Close the battery drawer. Note: When the batteries are installed correctly, the fan will turn on for a moment.

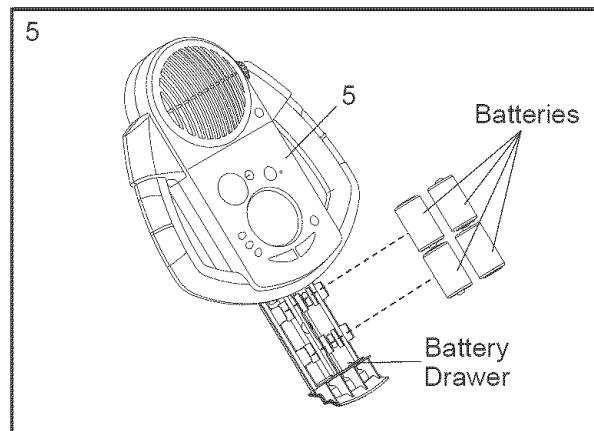

6. Identify the Left Handlebar (9), which is marked with a sticker. Insert the Left Handlebar into one of the Handlebar Legs (79); **make sure that the Handlebar Leg is turned so the hexagonal holes are on the indicated side.** Attach the Left Handlebar to the Handlebar Leg with two M8 x 45mm Button Bolts (50) and two M8 Nylon Locknuts (46). **Make sure that the Nylon Locknuts are inside of the hexagonal holes. Do not fully tighten the Button Bolts yet.**

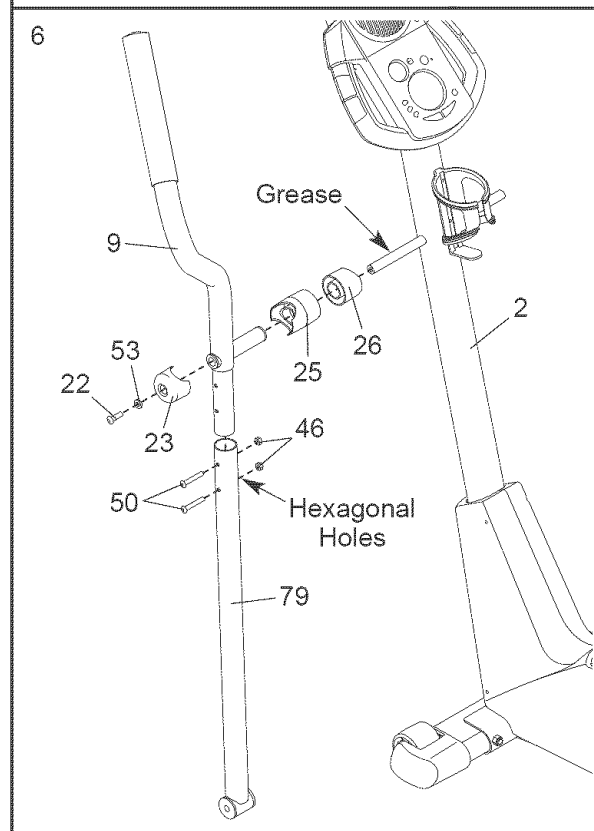

Apply a small amount of the included grease to the left and right axles on the Upright (2).

Carefully slide an Upright Spacer (26), a Handlebar Spacer (25), the Left Handlebar (9), and a Handlebar Cap (23) onto the left axle on the Upright (2) as shown. Slide an M10.3 Black Washer (53) onto an M8 x 19mm Shoulder Screw (22), and tighten the Shoulder Screw into the axle.

Attach the Right Handlebar and the other Handlebar Leg (not shown) in the same way.

7. Hold the lower end of the left Handlebar Leg (79) inside of the left Front Flex Bracket (17). Apply a small amount of grease to an M10 x 78mm Button Bolt (27). Attach the left Handlebar Leg to the left Front Flex Bracket with the Button Bolt, two M10 Washers (38), and an M10 Nylon Locknut (29). **Do not overtighten the Nylon Locknut; the left Handlebar Leg must be able to pivot freely.**

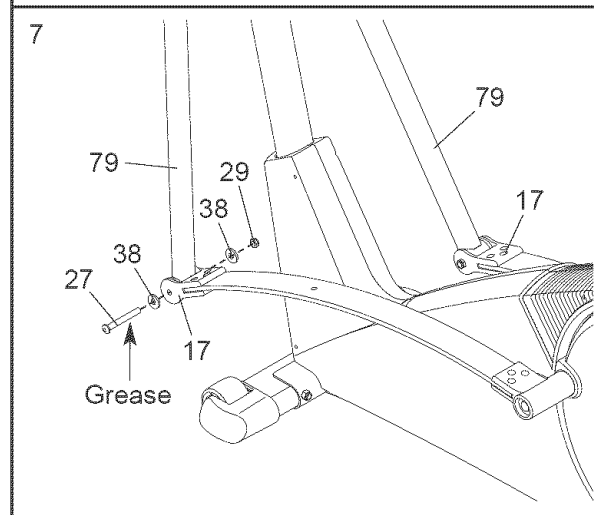

Attach the right Handlebar Leg (79) to the right Front Flex Bracket (17) in the same way.

Refer to step 6. Tighten the M8 x 45mm Button Bolts (50) in the Handlebar Legs (79). Refer to step 3. Tighten the M10 x 88mm Button Bolt (63).

8. Identify the Left Pedal (13). Attach the Left Pedal to the left Flex Bar (14) with an M10 x 33mm Carriage Bolt (20), an M10 Washer (38), and a Pedal Knob (15) as shown. Note: The Left Pedal can be attached in any of five positions (see HOW TO ADJUST THE PEDALS on page 9).

Attach the Right Pedal (not shown) in the same way.  
Make sure that both Pedals are in the same position.

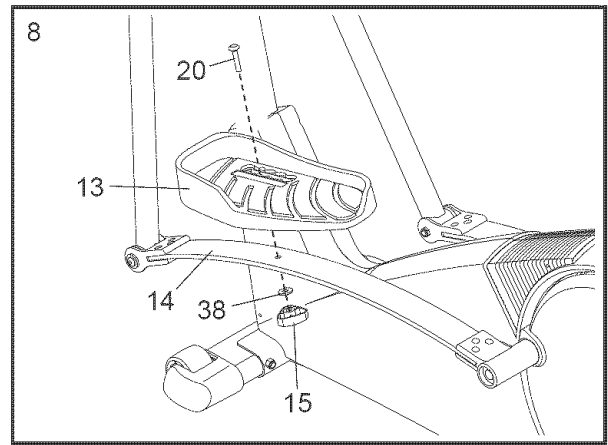

9. **Make sure that all parts of the elliptical crosstrainer are properly tightened.** Note: Some hardware may be left over after assembly is completed. To protect the floor or carpet from damage, place a mat under the elliptical crosstrainer.



# HOW TO USE THE ELLIPTICAL CROSSTRAINER

## HOW TO ADJUST THE PEDALS

The motion of the pedals is determined by their positions on the flex bars. There are five positions. To adjust each pedal, first loosen the knob beneath the pedal. Next, push the bolt upward, slide the pedal forward or backward to the desired position, and then retighten the knob. Make sure that both pedals are in the same position.

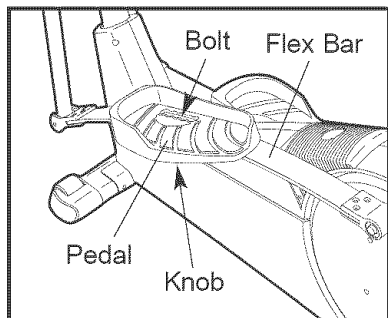

## HOW TO EXERCISE ON THE ELLIPTICAL CROSSTRAINER

To mount the elliptical crosstrainer, hold the handgrip pulse sensor and step onto the pedal that is in the lowest position. Then, step onto the other pedal. Push the pedals until they begin to move with a continuous motion. **Note: The pedal disks can turn in either direction. It is recommended that you move the pedal disks in the direction shown by the arrow below; however, for variety, you can turn the pedal disks in the opposite direction.**

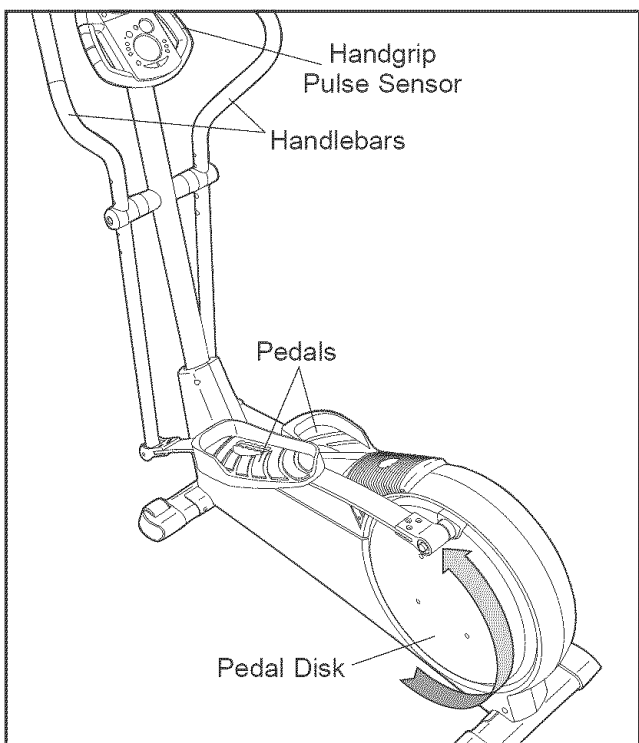

To dismount the elliptical crosstrainer, wait until the pedals come to a complete stop. **Note: The elliptical crosstrainer does not have a free wheel; the pedals will continue to move until the flywheel stops.** When the pedals are stationary, step off the highest pedal first. Then, step off the lowest pedal.

## HOW TO USE THE HANDLEBARS

The handlebars are designed to add upper-body exercise to your workouts. Push and pull the handlebars as you exercise to work your arms, shoulders, and back.

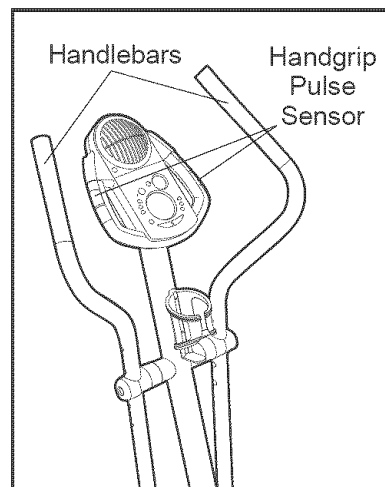

To exercise only your lower body, hold the handgrip pulse sensor as you exercise.

**CAUTION:** Before using the elliptical crosstrainer, read the following precautions.

- Always hold the handgrip pulse sensor or the handlebars when mounting, dismounting, or using the elliptical crosstrainer.
- When you stop exercising, allow the pedals to slowly come to a stop.
- The pulse sensor is not a medical device. Various factors may affect the accuracy of heart rate readings. The pulse sensor is intended only as an exercise aid in determining heart rate trends in general.

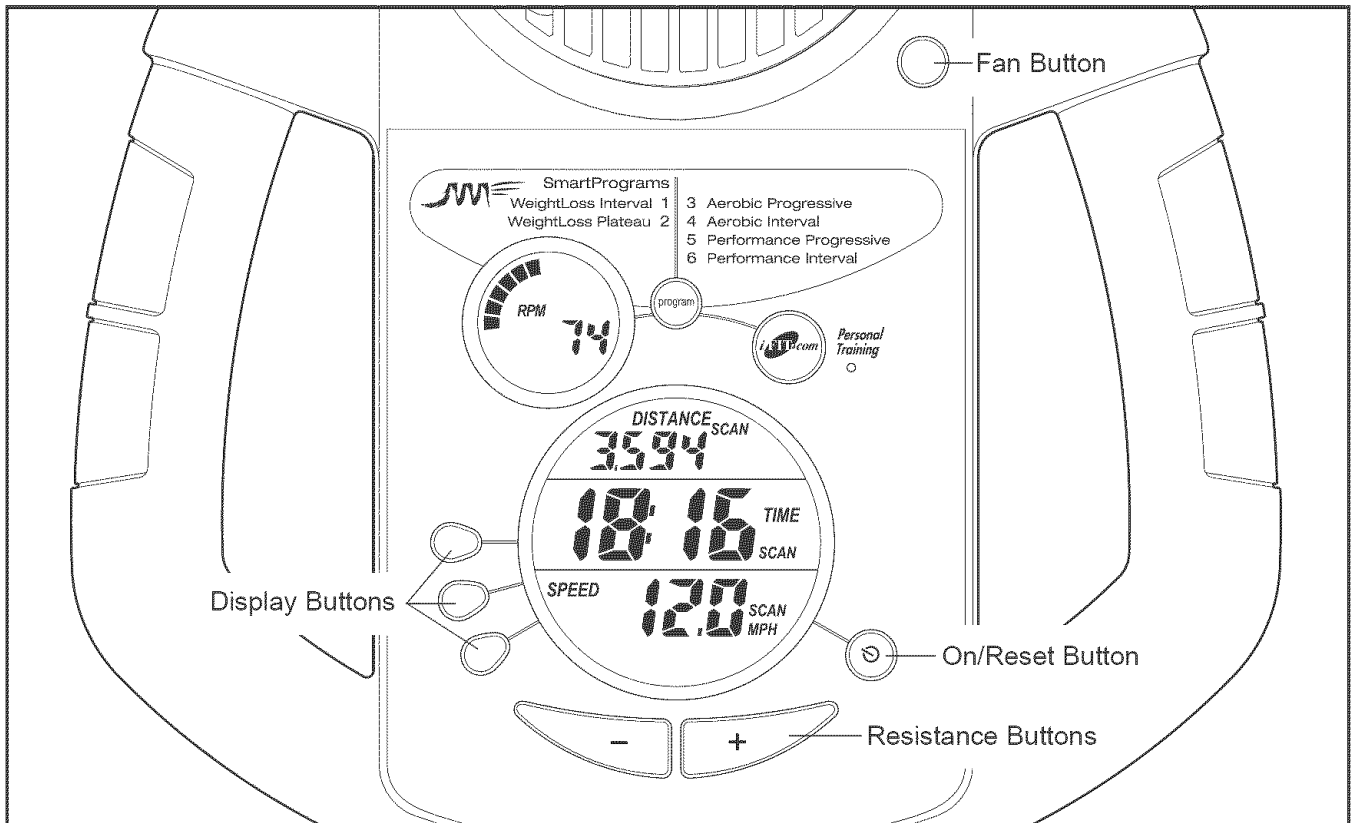

## FEATURES OF THE CONSOLE

The advanced console offers a selection of features designed to make your workouts more enjoyable and effective. When the manual mode of the console is selected, the resistance of the pedals can be changed with the touch of a button. As you pedal, the console will provide continuous exercise feedback. You can even measure your heart rate using the built-in hand-grip pulse sensor.

In addition, the console offers six Smart programs. Each program automatically changes the resistance of the pedals and prompts you to increase or decrease your pace as it guides you through an effective workout.

The console also features iFIT.com interactive technology. Having iFIT.com interactive technology is like having a personal trainer in your home. Using a stereo audio cable (available at electronics stores), you can connect the elliptical crosstrainer to your home stereo,

portable stereo, computer, or VCR and play special iFIT.com CD and video programs (iFIT.com CDs and videocassettes are available separately). iFIT.com CD and video programs automatically control the resistance of the pedals and prompt you to vary your pace as a personal trainer coaches you through every step of your workout. High-energy music provides added motivation. **To purchase iFIT.com CDs and videocassettes, call toll-free 1-800-735-0768.**

With the elliptical crosstrainer connected to your computer, you can also go to our Web site at [www.iFIT.com](http://www.iFIT.com) and access programs directly from the internet. **Explore [www.iFIT.com](http://www.iFIT.com) for more information.**

**To use the manual mode of the console, see page 11. To use a Smart program, see page 13. To use an iFIT.com CD or videocassette, see page 17. To use a program directly from our Web site, see page 18.**

## HOW TO USE THE MANUAL MODE

### 1 Turn on the console.

Note: The console requires four 1.5V “D” batteries (see assembly step 5 on page 7).

To turn on the console, press the On/Reset button or begin pedaling. (See the drawing on page 10 to identify the On/Reset button.)

### 2 Select the manual mode.

Each time the console is turned on, the manual mode will be selected. If a program has been selected, select the manual mode by pressing the Program button repeatedly until the letters RPM appear in the small display.

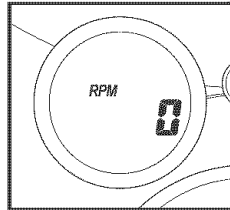

### 3 Begin pedaling and change the resistance of the pedals as desired.

As you pedal, change the resistance of the pedals by pressing the + and – buttons below the large display. There are ten resistance levels—level 10 is the most challenging. Note: After the buttons are pressed, it will take a few seconds for the resistance to reach the selected setting.

### 4 Follow your progress with the small display and the large display.

The small display will show your pedaling pace, in revolutions per minute (RPM). The indicator bar in the small display will increase or decrease in length as you increase or decrease your pedaling pace.

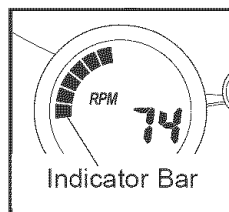

The upper section of the large display will show the distance you have pedaled

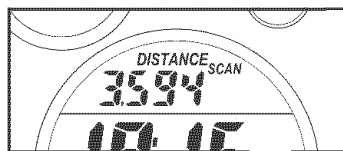

and the numbers of calories and fat calories you have burned (see FAT BURNING on page 20 for an explanation of fat calories). The display will change from one number to the next every few

seconds. If you use the handgrip pulse sensor, the display will also show your heart rate (see step 5 on page 12).

To view only the distance you have pedaled or the number of calories or fat calories you have burned, press the upper button on the left side of the large display until only the word DISTANCE, CALORIES, or FAT CALORIES appears in the upper section of the large display. Make sure that the word SCAN does not appear. To again view the distance you have pedaled and the numbers of calories and fat calories you have burned, press the upper button until the word SCAN reappears.

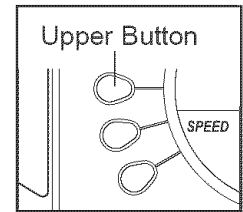

The center of the large display will show the elapsed time and your current pace (pace is shown in minutes per mile). The display will change from one number to the other every few seconds. Note: When a program is selected, the display will show the time remaining in the program instead of the elapsed time.

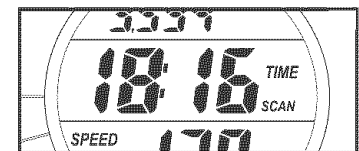

To view only the elapsed time or your pace, press the center button on the left side of the large display until only the word TIME or PACE appears. Make sure that the word SCAN does not appear. To view both the elapsed time and your pace, press the center button until the word SCAN reappears.

The lower section of the large display will show your pedaling speed and the resistance level.

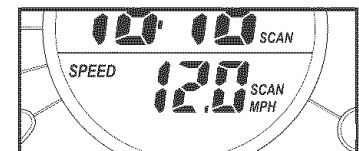

The display will change from one number to the other every few seconds.

To view only your pedaling speed or the resistance level, press the lower button on the left side of the large display until only the word SPEED or RESISTANCE appears. Make sure that the word SCAN does not appear. To view both your pedaling speed and the resistance level, press the lower button until the word SCAN reappears.

To reset the displays, press the On/Reset button.

**Note:** The console can show speed and distance in either miles or kilometers. The letters MPH or KM/H will appear in the lower section of the large display to show which system of measurement is selected. To change the system of measurement, hold down the On/Reset button for about six seconds. Note: When the button is held down, the fan will turn on for a moment. When the batteries are replaced, it may be necessary to reselect the desired system of measurement.



**5 Measure your heart rate if desired.**

If there are thin sheets of plastic on the metal contacts on the handgrips, peel off the plastic. To use the handgrip pulse sensor, hold the handgrips with your palms resting against the metal contacts. **Avoid moving your hands.** When your pulse is detected, the heart-shaped indicator in the large display will flash each time your heart beats. After a moment, two dashes (--) will appear and then your heart rate will be shown.

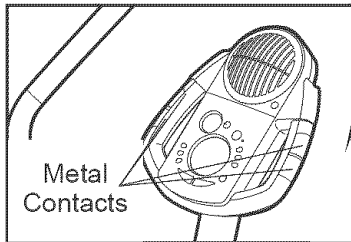

For the most accurate heart rate reading, continue to hold the handgrips for about 30 seconds. Note: When you first hold the handgrips, the large display will show your heart rate continuously for 30 seconds. The display will then show your heart rate along with other feedback modes.

**6 Turn on the fan if desired.**

To turn on the fan at low speed, press the fan button. To turn on the fan at high speed, press the fan button a second time. To turn off the fan, press the fan button a third time.

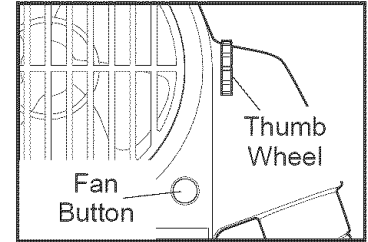

Rotate the thumb wheel on the right side of the console to pivot the fan to the desired angle.

**7 When you are finished exercising, the console will automatically turn off.**

If the pedals are not moved for a few seconds, the displays will pause and the time will flash in the large display.

If the pedals are not moved and the console buttons are not pressed for a few minutes, the console will turn off to conserve the batteries.

## HOW TO USE A SMART PROGRAM

Each Smart program will automatically change the resistance of the pedals and prompt you to increase or decrease your pace as it guides you through an effective workout. Programs 1 and 2 are weight loss programs, programs 3 and 4 are aerobic programs, and programs 5 and 6 are high-performance programs.

Follow the steps below to use a Smart program.

### 1 Turn on the console.

See step 1 on page 11.

### 2 Select one of the Smart programs.

Each time the console is turned on, the manual mode will be selected. To select a Smart program, press the Program button repeatedly until the number 1, 2, 3, 4, 5, or 6 appears in the small display.

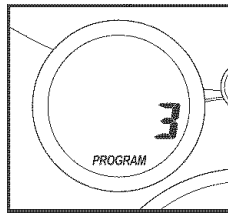

### 3 Begin pedaling to start the program.

To start the program, simply begin pedaling. Each Smart program consists of 20 or 30 one-minute periods. One resistance level and one target pace are programmed for each period. (The same resistance level and/or target pace may be programmed for two or more consecutive periods.)

At the end of each period of the program, the resistance of the pedals will automatically change if a different resistance level is programmed for the next period. Note: If the resistance level is too high or too low, you can change it by pressing the + and – buttons below the large display. However, when the current period is completed, the resistance of the pedals will automatically change if a different resistance level is programmed for the next period.

The target pace for the current period will be shown by the arrows in the small display. To pedal at the target pace, simply

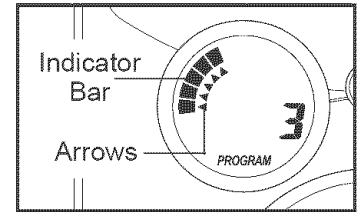

increase or decrease your pace until there is one arrow pointing to each segment of the indicator bar (see the drawing above). At the end of each period, the number of arrows will change if a different target pace is programmed for the next period. When the number of arrows changes, change your pace until there is again one arrow pointing to each segment of the indicator bar.

**Important: The target pace is intended only to provide a goal. Your actual pace may be slower than the target pace, especially during the first few months of your exercise program. Make sure to pedal at a pace that is comfortable for you.**

During the program, the center of the large display will show the time remaining in the program. If you stop pedaling for a few seconds, the displays will pause and the time will flash. If you continue pedaling after the program is completed, the displays will continue to show exercise feedback.

### 4 Follow your progress with the large display.

See step 4 on page 11.

### 5 Measure your heart rate if desired.

See step 5 on page 12.

### 6 Turn on the fan if desired.

See step 6 on page 12.

### 7 When you are finished exercising, the console will automatically turn off.

See step 7 on page 12.

## HOW TO CONNECT YOUR CD PLAYER, VCR, OR COMPUTER

To use iFIT.com CDs, the elliptical crosstrainer must be connected to your portable CD player, portable stereo, home stereo, or computer with CD player. See pages 14 and 15 for connecting instructions. To use iFIT.com videocassettes, the elliptical crosstrainer must be connected to your VCR. See page 16 for connecting instructions. To use iFIT.com programs directly from our Web site, the elliptical crosstrainer must be connected to your computer. See page 15.

## HOW TO CONNECT YOUR PORTABLE CD PLAYER

Note: If your CD player has separate LINE OUT and PHONES jacks, see instruction A below. If your CD player has only one jack, see instruction B.

- A. Plug one end of a 1/8" to 1/8" stereo audio cable (available at electronics stores) into the jack beneath the console. Plug the other end of the cable into the LINE OUT jack on your CD player. Plug your headphones into the PHONES jack.

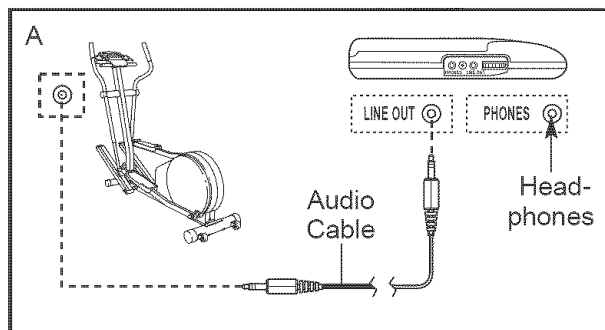

- B. Plug one end of a 1/8" to 1/8" stereo audio cable (available at electronics stores) into the jack beneath the console. Plug the other end of the cable into a 1/8" Y-adapter (available at electronics stores). Plug the Y-adapter into the PHONES jack on your CD player. Plug your headphones into the other side of the Y-adapter.

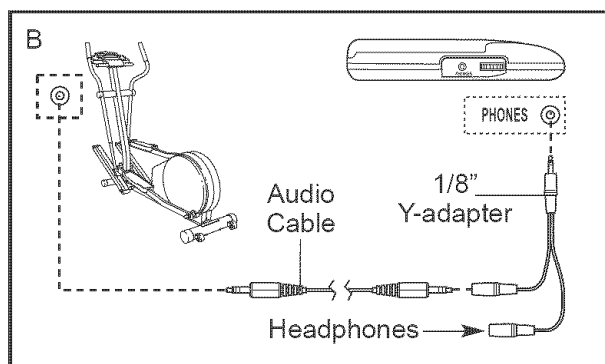

## HOW TO CONNECT YOUR PORTABLE STEREO

Note: If your stereo has an RCA-type AUDIO OUT jack, see instruction A below. If your stereo has a 1/8" LINE OUT jack, see instruction B. If your stereo has only a PHONES jack, see instruction C.

- A. Plug one end of a 1/8" to RCA stereo audio cable (available at electronics stores) into the jack beneath the console. Plug the other end of the cable into the AUDIO OUT jack on your stereo.

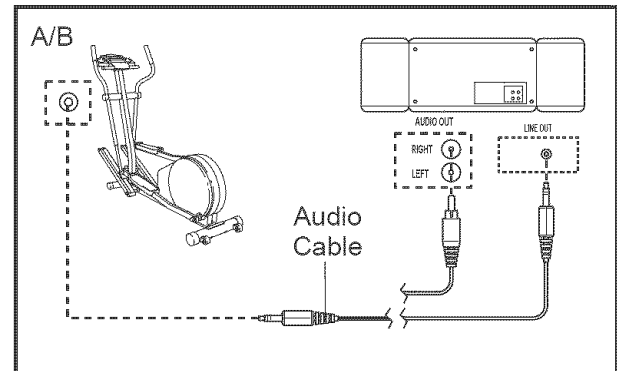

- B. Refer to the drawing above. Plug one end of a 1/8" to 1/8" stereo audio cable (available at electronics stores) into the jack beneath the console. Plug the other end of the cable into the LINE OUT jack on your stereo.

- C. Plug one end of a 1/8" to 1/8" stereo audio cable (available at electronics stores) into the jack beneath the console. Plug the other end of the cable into a 1/8" Y-adapter (available at electronics stores). Plug the Y-adapter into the PHONES jack on your stereo. Plug your headphones into the other side of the Y-adapter.

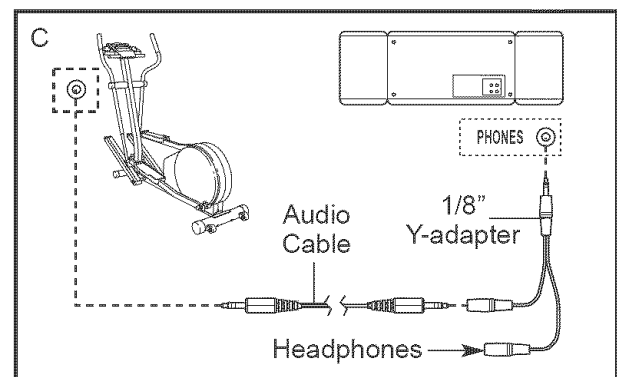

## HOW TO CONNECT YOUR HOME STEREO

**Note:** If your stereo has an unused LINE OUT jack, see instruction A below. If the LINE OUT jack is being used, see instruction B.

- A. Plug one end of a 1/8" to RCA stereo audio cable (available at electronics stores) into the jack beneath the console. Plug the other end of the cable into the LINE OUT jack on your stereo.

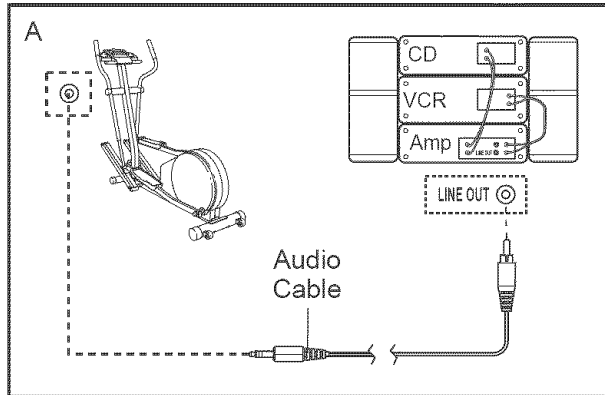

- B. Plug one end of a 1/8" to RCA stereo audio cable (available at electronics stores) into the jack beneath the console. Plug the other end of the cable into an RCA Y-adapter (available at electronics stores). Next, remove the wire that is currently plugged into the LINE OUT jack on your stereo and plug the wire into the unused side of the Y-adapter. Plug the Y-adapter into the LINE OUT jack on your stereo.

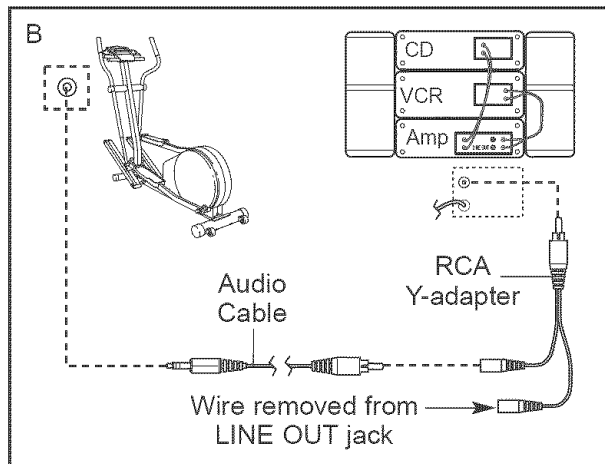

## HOW TO CONNECT YOUR COMPUTER

**Note:** If your computer has a 1/8" LINE OUT jack, see instruction A. If your computer has only a PHONES jack, see instruction B.

- A. Plug one end of a 1/8" to 1/8" stereo audio cable (available at electronics stores) into the jack beneath the console. Plug the other end of the cable into the LINE OUT jack on your computer.

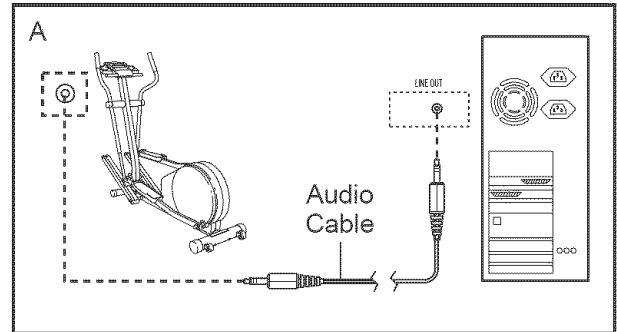

- B. Plug one end of a 1/8" to 1/8" stereo audio cable (available at electronics stores) into the jack beneath the console. Plug the other end of the cable into a 1/8" Y-adapter (available at electronics stores). Plug the Y-adapter into the PHONES jack on your computer. Plug your headphones or speakers into the other side of the Y-adapter.

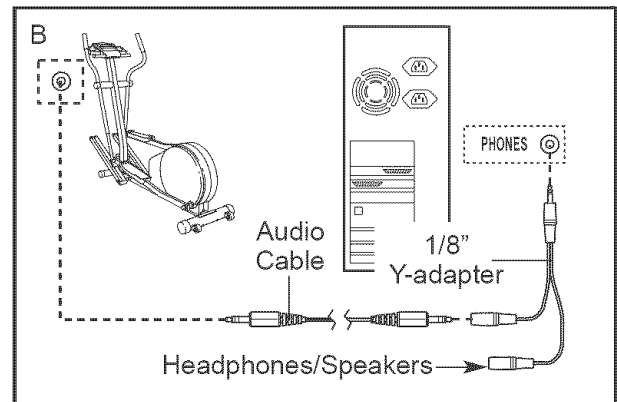

## HOW TO CONNECT YOUR VCR

**Note:** If your VCR has an unused AUDIO OUT jack, see instruction A below. If the AUDIO OUT jack is being used, see instruction B. If you have a TV with a built-in VCR, see instruction B. If your VCR is connected to your home stereo, see HOW TO CONNECT YOUR HOME STEREO on page 15.

- A. Plug one end of a 1/8" to RCA stereo audio cable (available at electronics stores) into the jack beneath the console. Plug the other end of the cable into the AUDIO OUT jack on your VCR.

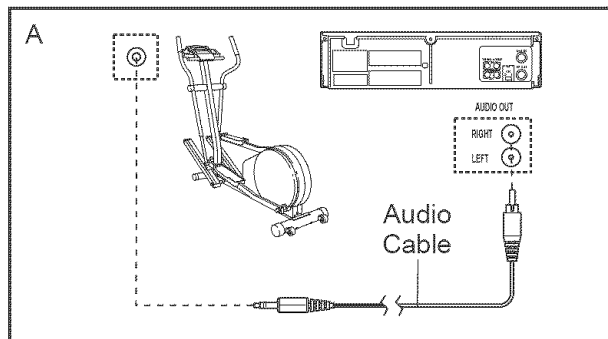

- B. Plug one end of a 1/8" to RCA stereo audio cable (available at electronics stores) into the jack beneath the console. Plug the other end of the cable into an RCA Y-adapter (available at electronics stores). Next, remove the wire that is currently plugged into the AUDIO OUT jack on your VCR and plug the wire into the unused side of the Y-adapter. Plug the Y-adapter into the AUDIO OUT jack on your VCR.

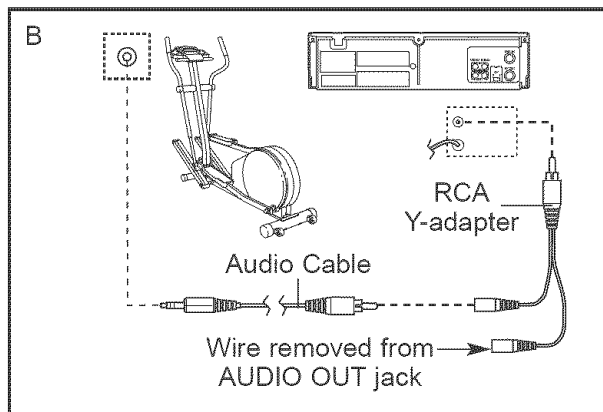



## HOW TO USE iFIT.COM CD AND VIDEO PROGRAMS

To use iFIT.com CDs or videocassettes, the elliptical crosstrainer must be connected to your portable CD player, portable stereo, home stereo, computer with CD player, or VCR. See HOW TO CONNECT YOUR CD PLAYER, VCR, OR COMPUTER on page 14. To purchase iFIT.com CDs and videocassettes, call toll-free 1-800-735-0768.

Follow the steps below to use an iFIT.com CD or video program.

### 1 Turn on the console.

See step 1 on page 11.

### 2 Select the iFIT.com mode.

Each time the console is turned on, the manual mode will be selected. To select the iFIT.com mode, press the iFIT.com button. The indicator near the button will light and the letters IF will appear in the small display.

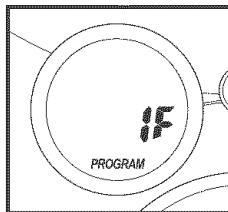

### 3 Insert the iFIT.com CD or videocassette.

If you are using an iFIT.com CD, insert the CD into your CD player. If you are using an iFIT.com videocassette, insert the videocassette into your VCR.

### 4 Press the play button on your CD player or VCR.

A moment after the play button is pressed, your personal trainer will begin guiding you through your workout. Simply follow your personal trainer's instructions.

The program will function in almost the same way as a Smart program (see step 3 on page 13). However, an electronic "chirping" sound will alert you when the resistance level and/or the target pace is about to change.

**Note: If the resistance of the pedals and/or the target pace does not change when a "chirp" is heard:**

- Make sure that the indicator near the iFIT.com button is lit.
- Adjust the volume of your CD player or VCR. If the volume is too high or too low, the console may not detect the program signals.
- Make sure that the audio cable is properly connected and that it is fully plugged in.

### 5 Follow your progress with the large display.

See step 4 on page 11.

### 6 Measure your heart rate if desired.

See step 5 on page 12.

### 7 Turn on the fan if desired.

See step 6 on page 12.

### 8 When you are finished exercising, the console will automatically turn off.

See step 7 on page 12.

## HOW TO USE PROGRAMS DIRECTLY FROM OUR WEB SITE

Our Web site at [www.iFIT.com](http://www.iFIT.com) allows you to play iFIT.com programs directly from the internet. To use programs from our Web site, the elliptical crosstrainer must be connected to your home computer. See HOW TO CONNECT YOUR COMPUTER on page 16. In addition, you must have an internet connection and an internet service provider. A list of specific system requirements will be found on our Web site.

Follow the steps below to use a program from our Web site.

### **1** Turn on the console.

See step 1 on page 11.

### **2** Select the iFIT.com mode.

Each time the console is turned on, the manual mode will be selected. To select the iFIT.com mode, press the iFIT.com button. The indicator near the button will light and the letters IF will appear in the small display.

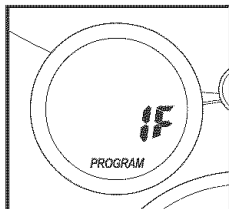

### **3** Go to your computer and start an internet connection.

### **4** Start your Web browser, if necessary, and go to our Web site at [www.iFIT.com](http://www.iFIT.com).

### **5** Follow the desired links on our Web site to select a program.

### **6** Follow the on-line instructions to start the program.

When you start the program, an on-screen countdown will begin.

### **7** Return to the elliptical crosstrainer and begin pedaling.

When the on-screen countdown ends, the program will begin. The program will function in almost the same way as a Smart program (see step 3 on page 13). However, an electronic “chirping” sound will alert you when the resistance level and/or the target pace is about to change.

### **8** Follow your progress with the large display.

See step 4 on page 11.

### **9** Measure your heart rate if desired.

See step 5 on page 12.

### **10** When you are finished exercising, the console will automatically turn off.

See step 7 on page 12.

---

# MAINTENANCE AND TROUBLESHOOTING

Inspect and tighten all parts of the elliptical crosstrainer regularly. Replace any worn parts immediately.

To clean the elliptical crosstrainer, use a damp cloth and a small amount of mild soap. **Important: To avoid damage to the console, keep liquids away from the console and keep the console out of direct sunlight.**

## BATTERY REPLACEMENT

If the console displays become dim, the batteries should be replaced; most console problems are the result of low batteries. Refer to assembly step 5 on page 7 for replacement instructions.

## HOW TO LEVEL THE ELLIPTICAL CROSSTRAINER

After the elliptical crosstrainer has been moved to the location where it will be used, make sure that the ends of both stabilizers are touching the floor. If the elliptical crosstrainer

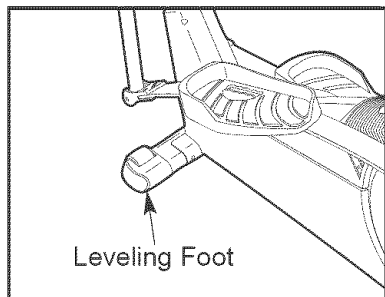

rocks slightly during use, turn one or both of the leveling feet under the front stabilizer until the rocking motion is eliminated.

## HANDGRIP PULSE SENSOR TROUBLESHOOTING

- Avoid moving your hands while using the handgrip pulse sensor. Excessive movement may interfere with heart rate readings.
- Do not hold the metal contacts too tightly; doing so may interfere with heart rate readings.
- For the most accurate heart rate reading, hold the metal contacts for about 30 seconds.
- For optimal performance of the handgrip pulse sensor, keep the metal contacts clean. The contacts can be cleaned with a soft cloth—never use alcohol, abrasives, or chemicals.

# CONDITIONING GUIDELINES



## WARNING:

- Before beginning this or any exercise program, consult your physician. This is especially important for persons over the age of 35 or persons with pre-existing health problems.
- The pulse sensor is not a medical device. Various factors may affect the accuracy of heart rate readings. The pulse sensor is intended only as an exercise aid in determining heart rate trends in general.

The following guidelines will help you to plan your exercise program. Remember that proper nutrition and adequate rest are essential for successful results.

### EXERCISE INTENSITY

Whether your goal is to burn fat or to strengthen your cardiovascular system, the key to achieving the desired results is to exercise with the proper intensity. The proper intensity level can be found by using your heart rate as a guide. The chart below shows recommended heart rates for fat burning, maximum fat burning, and cardiovascular (aerobic) exercise.

165	155	145	140	130	125	115	
145	138	130	125	118	110	103	
125	120	115	110	105	95	90	
20	30	40	50	60	70	80	

To find the proper heart rate for you, first find your age at the bottom of the chart (ages are rounded off to the nearest ten years). Next, find the three numbers above your age. The three numbers are your "training zone." The lower two numbers are recommended heart rates for fat burning; the highest number is the recommended heart rate for aerobic exercise.

### Fat Burning

To burn fat effectively, you must exercise at a relatively low intensity level for a sustained period of time.

During the first few minutes of exercise, your body uses easily accessible carbohydrate calories for energy. Only after the first few minutes of exercise does your body begin to use stored fat calories for energy. If your goal is to burn fat, adjust the intensity of your exercise until your heart rate is near the lowest number in your training zone as you exercise.

For maximum fat burning, adjust the intensity of your exercise until your heart rate is near the middle number in your training zone as you exercise.

### Aerobic Exercise

If your goal is to strengthen your cardiovascular system, your exercise must be "aerobic." Aerobic exercise is activity that requires large amounts of oxygen for prolonged periods of time. This increases the demand on the heart to pump blood to the muscles, and on the lungs to oxygenate the blood. For aerobic exercise, adjust the intensity of your exercise until your heart rate is near the highest number in your training zone as you exercise.

### WORKOUT GUIDELINES

Each workout should include the following three parts:

**A warm-up**, consisting of 5 to 10 minutes of stretching and light exercise (see SUGGESTED STRETCHES on page 21). A proper warm-up increases your body temperature, heart rate, and circulation in preparation for exercise.

**Training zone exercise**, consisting of 20 to 30 minutes of exercising with your heart rate in your training zone. Note: During the first few weeks of your exercise program, do not keep your heart rate in your training zone for longer than 20 minutes.

**A cool-down**, with 5 to 10 minutes of stretching. This will increase the flexibility of your muscles and will help to prevent post-exercise problems.

### EXERCISE FREQUENCY

To maintain or improve your condition, complete three workouts each week, with at least one day of rest between workouts. After a few months of regular exercise, you may complete up to five workouts each week if desired. The key to success is to make exercise a regular and enjoyable part of your everyday life.

## SUGGESTED STRETCHES

The correct form for several basic stretches is shown at the right. Move slowly as you stretch—never bounce.

### 1. Toe Touch Stretch

Stand with your knees bent slightly and slowly bend forward from your hips. Allow your back and shoulders to relax as you reach down toward your toes as far as possible. Hold for 15 counts, then relax. Repeat 3 times. Stretches: Hamstrings, back of knees and back.

### 2. Hamstring Stretch

Sit with one leg extended. Bring the sole of the opposite foot toward you and rest it against the inner thigh of your extended leg. Reach toward your toes as far as possible. Hold for 15 counts, then relax. Repeat 3 times for each leg. Stretches: Hamstrings, lower back and groin.

### 3. Calf/Achilles Stretch

With one leg in front of the other, reach forward and place your hands against a wall. Keep your back leg straight and your back foot flat on the floor. Bend your front leg, lean forward and move your hips toward the wall. Hold for 15 counts, then relax. Repeat 3 times for each leg. To cause further stretching of the achilles tendons, bend your back leg as well. Stretches: Calves, achilles tendons and ankles.

### 4. Quadriceps Stretch

With one hand against a wall for balance, reach back and grasp one foot with your other hand. Bring your heel as close to your buttocks as possible. Hold for 15 counts, then relax. Repeat 3 times for each leg. Stretches: Quadriceps and hip muscles.

### 5. Inner Thigh Stretch

Sit with the soles of your feet together and your knees outward. Pull your feet toward your groin area as far as possible. Hold for 15 counts, then relax. Repeat 3 times. Stretches: Quadriceps and hip muscles.

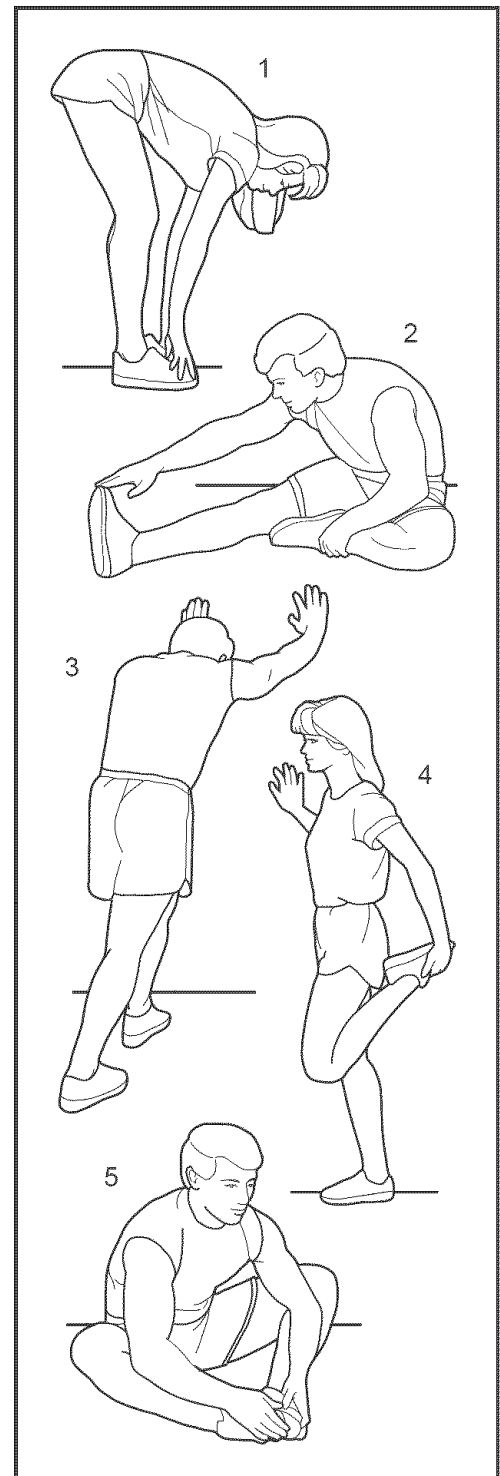

# PART LIST—Model No. PFEL39030

R0603A

Key No.	Qty.	Description	Key No.	Qty.	Description
1	1	Frame	50	4	M8 x 45mm Button Bolt
2	1	Upright	51	4	M6 x 18mm Bolt
3	1	Front Stabilizer	52	1	“C” Magnet Bracket
4	1	Rear Stabilizer	53	2	M10.3 Black Washer
5	1	Console	54	1	“C” Magnet
6	1	Left Side Shield	55	1	Motor
7	1	Right Side Shield	56	1	Belt
8	2	Pedal Disc	57	2	M8 x 33mm Button Bolt
9	1	Left Handlebar	58	12	M6 Washer
10	1	Right Handlebar	59	16	M6 Nylon Locknut
11	2	Foam Grip	60	4	M6 Nut
12	1	Right Pedal	61	4	M5 Nylon Locknut
13	1	Left Pedal	62	4	M5 x 12mm Bolt
14	2	Flex Bar	63	1	M10 x 88mm Button Screw
15	2	Pedal Knob	64	2	M4 x 6mm Self-tapping Screw
16	1	Left Flex Bracket	65	8	M5 x 33mm Screw
17	2	Front Flex Bracket	66	6	M4 x 16mm Screw
18	4	Rear Flex Bushing	67	4	M4 x 25mm Screw
19	12	M6 x 33mm Flat Bolt	68	1	Right Front Endcap
20	2	M10 x 33mm Carriage Bolt	69	1	Reed Switch Clamp
21	4	Snap Ring	70	1	M10 Split Washer
22	2	M8 x 19mm Shoulder Screw	71	2	Handlebar Endcap
23	2	Handlebar Cap	72	2	Leveling Foot
24	4	Handlebar Bushing	73	1	M5 x 16mm Screw
25	2	Handlebar Spacer	74	8	M4 x 19mm Screw
26	2	Upright Spacer	75	2	M6 Eyebolt
27	2	M10 x 78mm Button Bolt	76	1	Spring
28	4	Front Flex Bushing	77	1	Reed Switch
29	6	M10 Nylon Locknut	78	1	Reed Switch Bracket
30	1	Upright Bushing	79	2	Handlebar Leg
31	1	Left Front Endcap	80	1	Side Shield Cover
32	2	Wheel	81	1	“U” Bracket
33	2	M6 x 72mm Button Screw	82	1	Right Flex Bracket
34	4	M10 x 112mm Carriage Bolt	83	1	Frame Spacer
35	2	Rear Stabilizer Endcap	84	4	M4 x 12mm Tap Screw
36	1	Left Crank Arm	85	2	M5 Nut
37	1	Pulley	86	1	Upper Wire Harness
38	6	M10 Washer	87	1	Lower Wire Harness
39	1	Crank	88	2	Flex Bracket Spacer
40	2	Crank Bearing	89	2	M8 x 22mm Button Bolt
41	1	Flywheel	90	4	Motor Washer
42	2	Flywheel Bearing	91	1	Water Bottle Holder
43	1	Magnet	92	4	M8 Nut
44	1	Flywheel Axle	93	2	M4 x 22mm Screw
45	4	M8.5mm Washer	94	1	M6 Large Washer
46	7	M8 Nylon Locknut	#	2	Allen Wrench
47	2	Crank Screw	#	1	Grease
48	1	Right Crank Arm	#	1	User’s Manual
49	1	M6 x 25mm Bolt			

Note: “#” indicates a non-illustrated part. Specifications are subject to change without notice. See the back cover of this manual for information about ordering replacement parts.



---

# HOW TO ORDER REPLACEMENT PARTS

To order replacement parts, simply call our Customer Service Department toll-free at 1-800-999-3756, Monday through Friday, 6 a.m. until 6 p.m. Mountain Time (excluding holidays). To help us assist you, please be prepared to give the following information when calling:

- The MODEL NUMBER of the product (PFEL39030)
- The NAME of the product (PROFORM® 800 CARDIO CROSSTRAINER)
- The SERIAL NUMBER of the product (see the front cover of this manual)
- The KEY NUMBER and DESCRIPTION of the part(s) (see page 22)

## LIMITED WARRANTY

ICON Health & Fitness, Inc. (ICON), warrants this product to be free from defects in workmanship and material, under normal use and service conditions, for a period of ninety (90) days from the date of purchase. This warranty extends only to the original purchaser. ICON's obligation under this warranty is limited to replacing or repairing, at ICON's option, the product through one of its authorized service centers. All repairs for which warranty claims are made must be pre-authorized by ICON. This warranty does not extend to any product or damage to a product caused by or attributable to freight damage, abuse, misuse, improper or abnormal usage or repairs not provided by an ICON authorized service center; products used for commercial or rental purposes; or products used as store display models. No other warranty beyond that specifically set forth above is authorized by ICON.

ICON is not responsible or liable for indirect, special or consequential damages arising out of or in connection with the use or performance of the product or damages with respect to any economic loss, loss of property, loss of revenues or profits, loss of enjoyment or use, costs of removal or installation or other consequential damages of whatsoever nature. Some states do not allow the exclusion or limitation of incidental or consequential damages. Accordingly, the above limitation may not apply to you.

The warranty extended hereunder is in lieu of any and all other warranties and any implied warranties of merchantability or fitness for a particular purpose is limited in its scope and duration to the terms set forth herein. Some states do not allow limitations on how long an implied warranty lasts. Accordingly, the above limitation may not apply to you.

This warranty gives you specific legal rights. You may also have other rights which vary from state to state.

**ICON HEALTH & FITNESS, INC., 1500 S. 1000 W., LOGAN, UT 84321-9813**