

PRO-FORM[®]

1280 S

INTERACTIVE TRAINER

Model No. PFEL13031

Serial No. _____

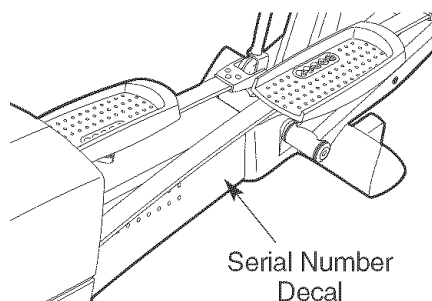

USER'S MANUAL

QUESTIONS?

If you have questions, or if there are missing parts, we will guarantee complete satisfaction through direct assistance from our factory.

TO AVOID DELAYS, PLEASE CALL DIRECT TO OUR TOLL-FREE CUSTOMER HOT LINE. The trained technicians on our customer hot line will provide immediate assistance, free of charge to you.

CUSTOMER HOT LINE:

1-888-533-1333

Mon.-Fri., 6 a.m.-6 p.m. MST

Patent Pending

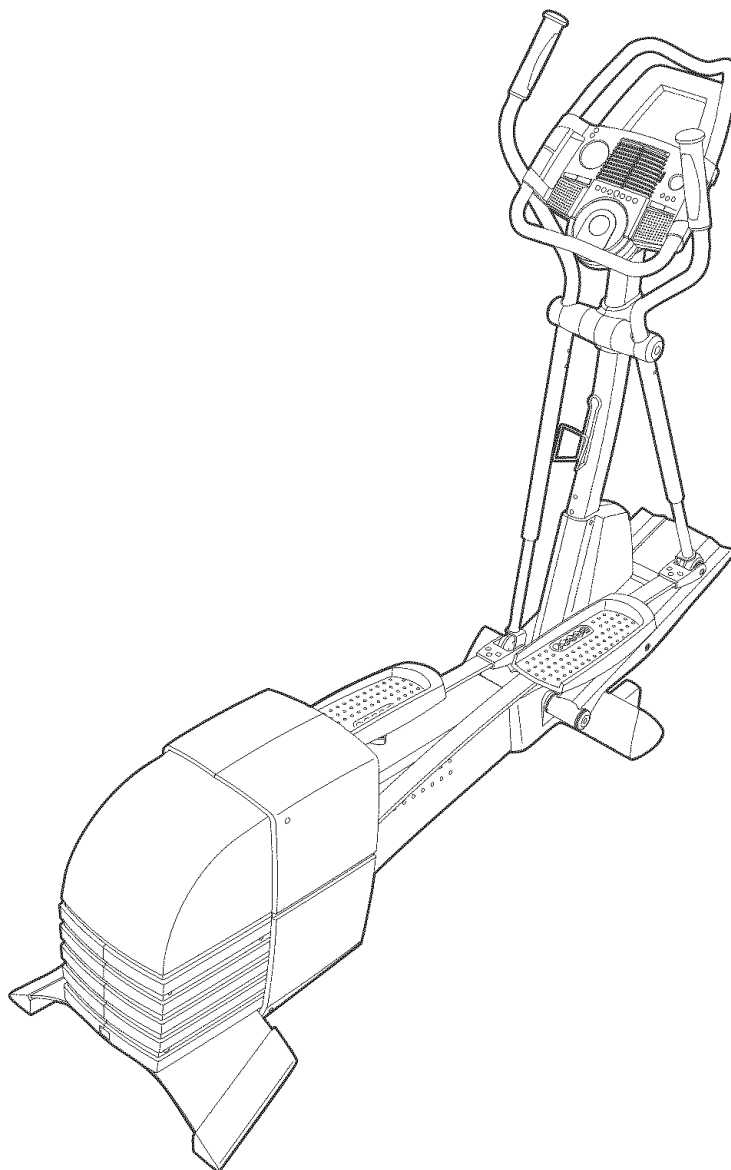

▲ CAUTION

Read all precautions and instructions in this manual before using this equipment. Keep this manual for future reference.



Visit our website at

www.proform.com

*new products, prizes,
fitness tips, and much more!*

PRO-FORM[®] 1280 S INTERACTIVE TRAINER

TABLE OF CONTENTS

IMPORTANT PRECAUTIONS	3
BEFORE YOU BEGIN	4
ASSEMBLY	5
HOW TO USE THE ELLIPTICAL EXERCISER	11
MAINTENANCE AND TROUBLESHOOTING	22
CONDITIONING GUIDELINES	23
PART LIST	24
EXPLODED DRAWING	26
HOW TO ORDER REPLACEMENT PARTS	Back Cover
LIMITED WARRANTY	Back Cover

IMPORTANT PRECAUTIONS

⚠ WARNING: To reduce the risk of serious injury, read the following important precautions before using the elliptical exerciser.

1. Read all instructions in this manual before using the elliptical exerciser.
2. It is the responsibility of the owner to ensure that all users of the elliptical exerciser are adequately informed of all precautions.
3. The elliptical exerciser is intended for home use only. Do not use the elliptical exerciser in a commercial, rental, or institutional setting.
4. Place the elliptical exerciser on a level surface, with a mat beneath it to protect the floor or carpet. Keep the elliptical exerciser indoors, away from moisture and dust.
5. Inspect and properly tighten all parts regularly. Replace any worn parts immediately.
6. Keep children under 12 and pets away from the elliptical exerciser at all times.
7. The elliptical exerciser should not be used by persons weighing more than 250 pounds.
8. Wear appropriate exercise clothes when using the elliptical exerciser. Always wear athletic shoes for foot protection while exercising.
9. Hold the center handlebar or the left and right handlebars while mounting, dismounting, or using the elliptical exerciser.
10. The pulse sensor is not a medical device. Various factors may affect the accuracy of heart rate readings. The pulse sensor is intended only as an exercise aid in determining heart rate trends in general.
11. Keep your back straight when using the elliptical exerciser; do not arch your back.
12. If you feel pain or dizziness while exercising, stop immediately and cool down.
13. When you stop exercising, allow the pedals to slowly come to a complete stop. The elliptical exerciser does not have a free wheel; the pedals will continue to move until the flywheel stops.
14. Always unplug the power cord immediately after use and before cleaning the elliptical exerciser.
15. The decals shown below have been placed on the elliptical exerciser. If a decal is missing or illegible, please call our Customer Service Department toll-free at 1-888-533-1333 and order a free replacement decal. Apply the decal in the location shown.

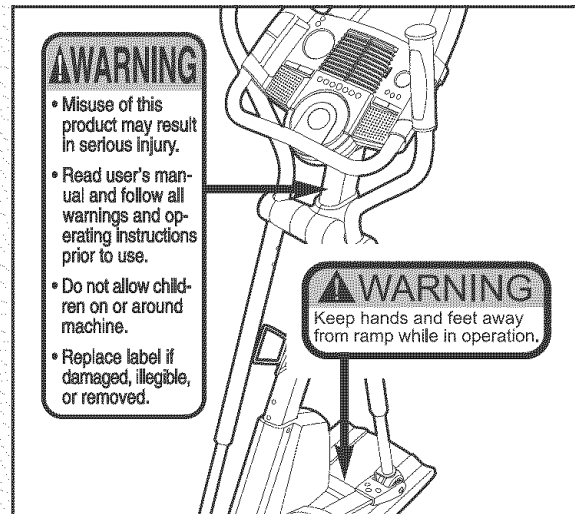

⚠ WARNING: Before beginning this or any exercise program, consult your physician. This is especially important for persons over the age of 35 or persons with pre-existing health problems. Read all instructions before using. ICON assumes no responsibility for personal injury or property damage sustained by or through the use of this product.

BEFORE YOU BEGIN

Thank you for selecting the new PROFORM® 1280 S elliptical exerciser. The PROFORM® 1280 S is an incredibly smooth exerciser that moves your feet in a natural elliptical path, minimizing the impact on your knees and ankles. And the unique 1280 S features adjustable resistance and a state-of-the-art console to help you get the most from your exercise. Welcome to a whole new world of natural, elliptical-motion exercise from PROFORM.



tions after reading this manual, call our Customer Service Department toll-free at 1-888-533-1333, Monday through Friday, 6 a.m. until 6 p.m. Mountain Time (excluding holidays). To help us assist you, please note the product model number and serial number before calling. The model number is PFEL13031. The serial number can be found on a decal attached to the elliptical exerciser (see the front cover of this manual for the location of the decal).

For your benefit, read this manual carefully before you use the elliptical exerciser. If you have ques-

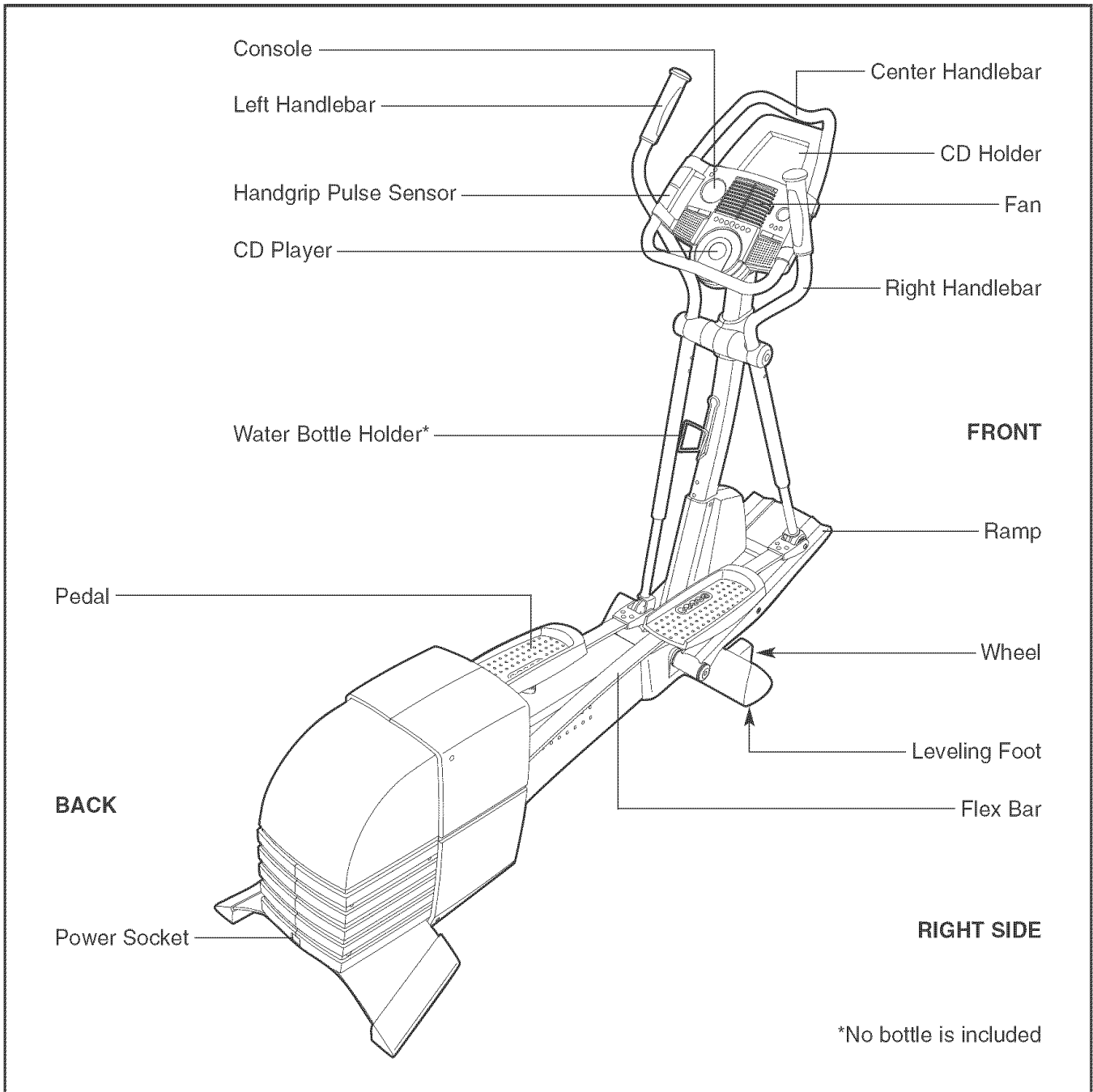
Before reading further, please familiarize yourself with the parts that are labeled in the drawing below.



ASSEMBLY

Assembly requires two persons. Place all parts of the elliptical exerciser in a cleared area and remove the packing materials. Do not dispose of the packing materials until assembly is completed. In addition to the included allen wrenches, assembly requires a phillips screwdriver , an adjustable wrench , and a rubber mallet .

See the drawings below to identify the small parts needed for assembly. The number in parentheses below each drawing is the key number of the part, from the PART LIST on pages 24 and 25. The number following the key number is the quantity needed for assembly. **Note: Some small parts may have been pre-assembled. If a part is not found in the parts bag, check to see if it has been pre-assembled.**

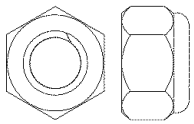

M8 Nylon Locknut (46)–4

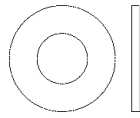

M6 Washer (58)–2

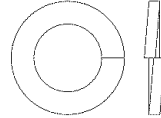

M8 Split Washer (94)–10

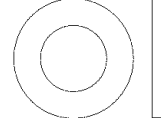

M8.5 Small Washer (53)–2

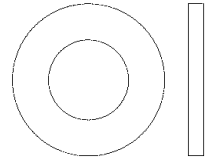

M10 Washer (99)–2

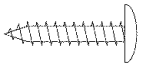

M4 x 16mm Screw (66)–12

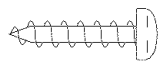

M4 x 16mm Round Head Screw (45)–1

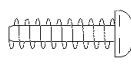

M4 x 14mm Round Head Screw (93)–2

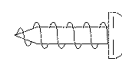

M4 x 12mm Round Head Screw (18)–2

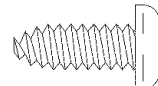

M6 x 16mm Tapered Button Screw (107)–8

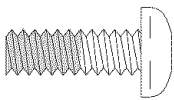

M6 x 18mm Patch Screw (67)–4

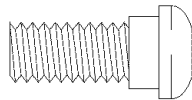

M8 x 19mm Shoulder Screw (22)–2

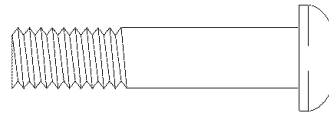

M8 x 38mm Button Screw (70)–2

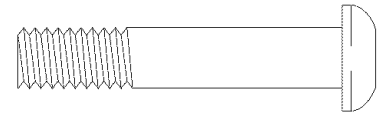

M8 x 43mm Button Bolt (50)–4

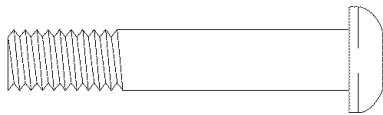

M8 x 45mm Button Screw (102)–4

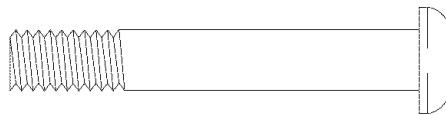

M8 x 54mm Button Screw (33)–4

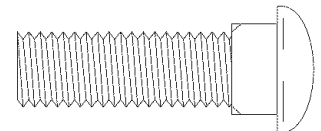

M10 x 35mm Carriage Bolt (20)–2

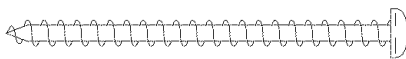

M4 x 52mm Screw (98)–2

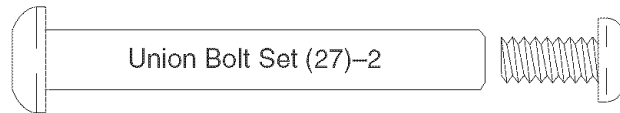

Union Bolt Set (27)–2

1. While another person lifts the front of the Frame (1), thread a Leveling Foot (72) fully into the underside of the Frame.

Next, attach the Front Stabilizer (3) to the front of the Frame (1) with two M8 x 54mm Button Screws (33) and two M8 Split Washers (94).

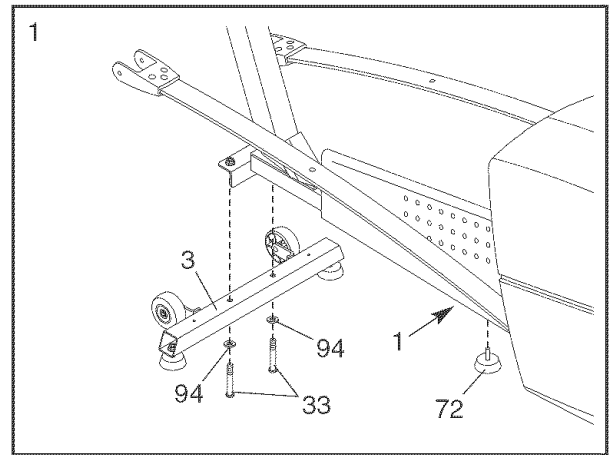

2. Move and lift the left Flex Bar (14) out of the way and slide the Left Stabilizer Cover (31) onto the Front Stabilizer (3). Slide the Right Stabilizer Cover (116) onto the Front Stabilizer in the same way.

While another person lifts the front of the Frame (1), attach the Left and Right Stabilizer Covers (31, 116) to the Front Stabilizer (3) with two M4 x 52mm Screws (98).

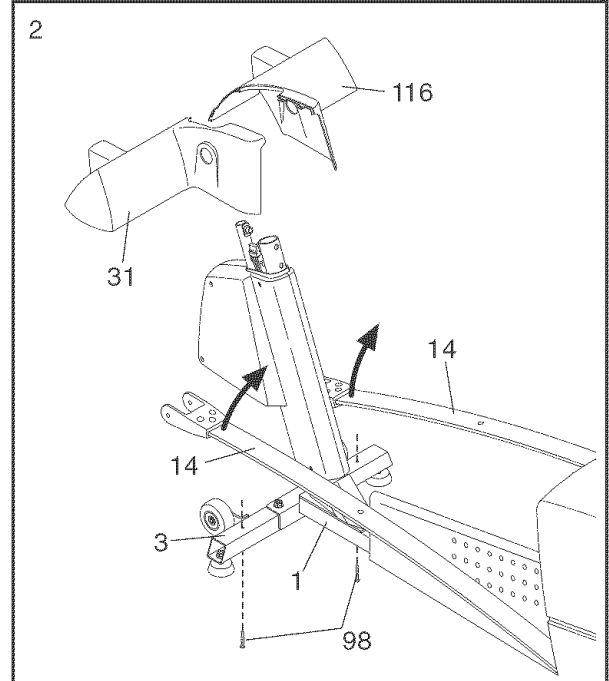

3. With the help of a second person, carefully tip the elliptical exerciser onto one side.

Make sure that the Left and Right Stabilizer Endcaps (35, 92) are on the Rear Stabilizer (4).

Attach the Rear Stabilizer (4) to the Frame (1) with four M8 x 45mm Button Screws (102) and four M8 Split Washers (94). **Note: There are wires (not shown) inside of the Frame. Be careful to avoid damaging the wires with the Button Screws.**

With the help of a second person, carefully tip the elliptical exerciser back to the vertical position.

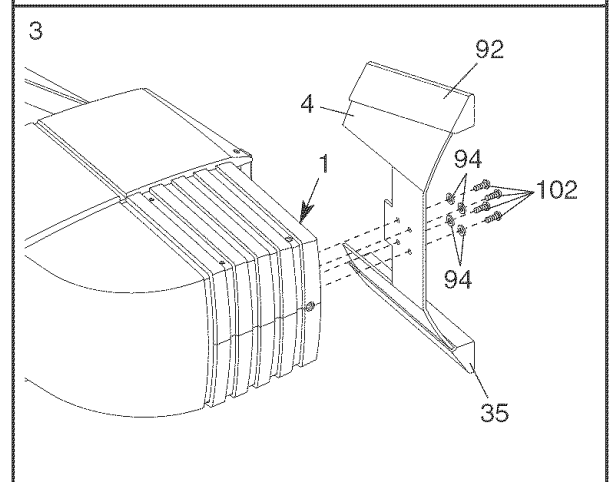

- Identify the Ramp Axle (128), which is the longest axle. Slide a Ramp Axle Cover (132) onto an M6 x 18mm Patch Screw (67) as shown. Tighten the Patch Screw into one end of the Ramp Axle. Apply a small amount of the included grease to the Ramp Axle.

Have a second person hold the two Ramp Spacers (130) against the sides of the Frame (1) so they cover the indicated tubes on the Frame. Lift the Flex Bars (not shown) out of the way and align the round tubes on the Ramp (133) with the Ramp Spacers. **Make sure that the Ramp is turned as shown.** Insert the Ramp Axle (128) into the Ramp, the Ramp Spacers, and the Frame. Note: It may be helpful to use a rubber mallet.

Slide the other Ramp Cover (132) onto an M6 x 18mm Patch Screw (67) as shown. Tighten the Patch Screw into the other end of the Ramp Axle (128).

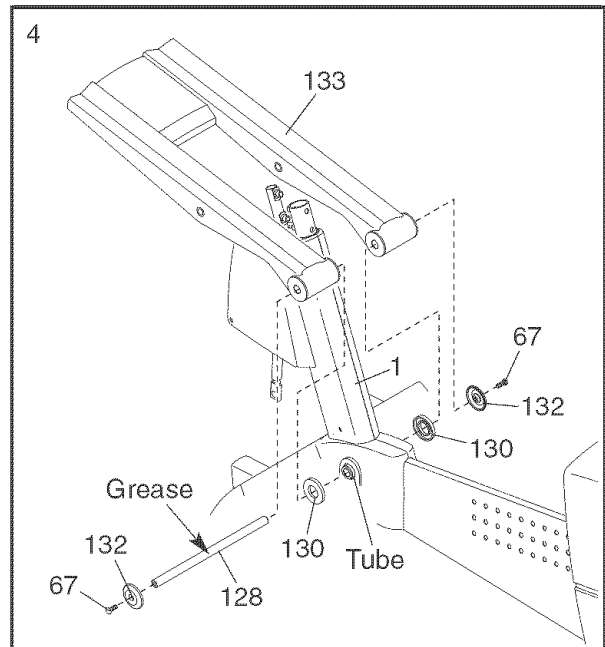

- Identify the Incline Axle (137), which is the longest remaining axle. Slide an M6 Washer (58) onto an M6 x 18mm Patch Screw (67). Tighten the Patch Screw into one end of the Incline Axle. Apply a small amount of grease to the Incline Axle.

Raise the Ramp (133). Insert the Incline Axle (137) into one side of the Ramp, through an Incline Spacer (123), through the motor screw, through the other Incline Spacer, and then into the other side of the Ramp. **As you insert the Incline Axle through the motor screw, make sure that the motor screw does not turn.**

Slide an M6 Washer (58) onto an M6 x 18mm Patch Screw (67). Tighten the Patch Screw into the other end of the Incline Axle (137).

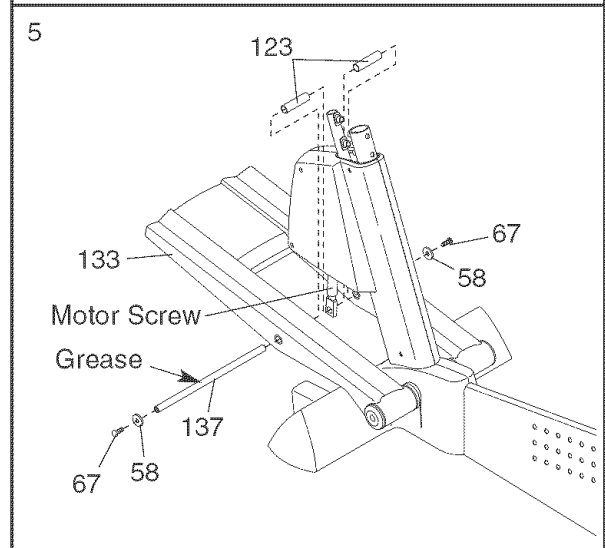

- Have another person hold the Upright (2) near the Frame (1). Connect the Upper Wire Harness (86) to the Lower Wire Harness (87). Next, slide the Upright onto the Frame. **Be careful to avoid disconnecting or pinching the Wire Harnesses.** Attach the Upright with two M8 x 54mm Button Screws (33), two M8 x 38mm Button Screws (70), and four M8 Split Washers (94). **Be careful to avoid damaging the Wire Harnesses with the Button Screws.**

Attach the Water Bottle Holder (91) to the Upright (2) with two M4 x 16mm Screws (66).

Hold the Left and Right Handlebar Covers (26, 29) around the Upright (2) and the indicated tube. Press the Handlebar Covers together and connect them with an M4 x 16mm Round Head Screw (45).

Hold the Left and Right Upright Covers (34, 38) around the Upright (2). Attach the Upright Covers with two M4 x 14mm Round Head Screws (93).

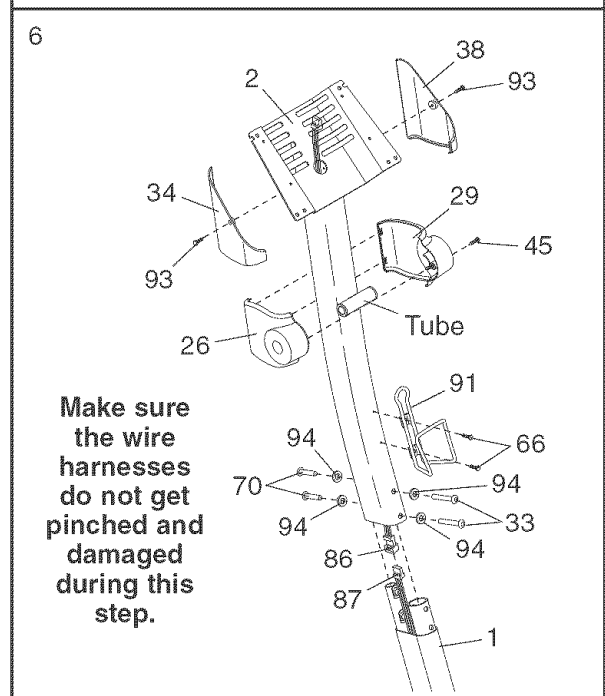

- Identify the Left Handlebar (9), which is marked with a sticker. Insert the Left Handlebar into one of the Handlebar Legs (79); **make sure that the Handlebar Leg is turned so the hexagonal holes are on the indicated side.** Attach the Left Handlebar with two M8 x 43mm Button Bolts (50) and two M8 Nylon Locknuts (46). **Do not tighten the Button Bolts yet. Make sure that the Nylon Locknuts are seated in the hexagonal holes.**

Attach the Right Handlebar (not shown) to the other Handlebar Leg (not shown) in the same way.

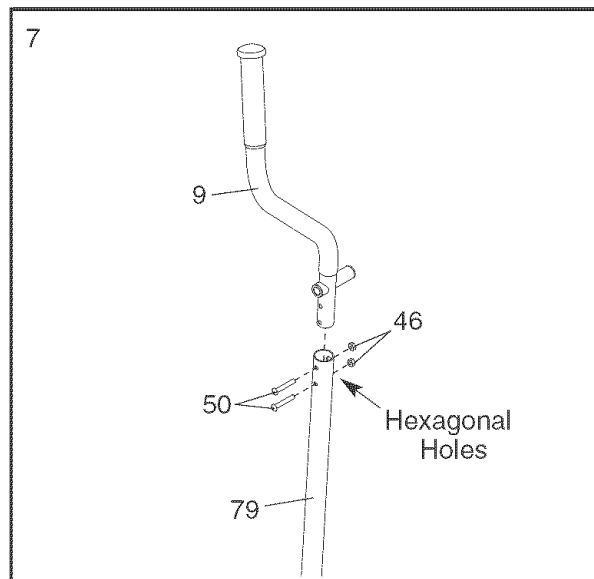

- Apply a generous amount of grease to the Pivot Axle (108) and to the two M8.5 Small Washers (53). Insert the Pivot Axle into the Upright (2) and center it. Reapply grease to both sides of the Pivot Axle.

Identify the Left and Right Handlebars (9, 10), which are marked with stickers. Slide a Handlebar Spacer (25) onto the short tube on each Handlebar, and slide the Handlebars onto the Pivot Axle (108). **Make sure that the Handlebars are on the correct sides.**

Orient the two Handlebar Caps (23) as shown, and press the small tabs on the Handlebar Caps into the two Handlebar Spacers (25). Tighten an M8 x 19mm Shoulder Screw (22) with an M8.5 Small Washer (53) into each end of the Pivot Axle (108).

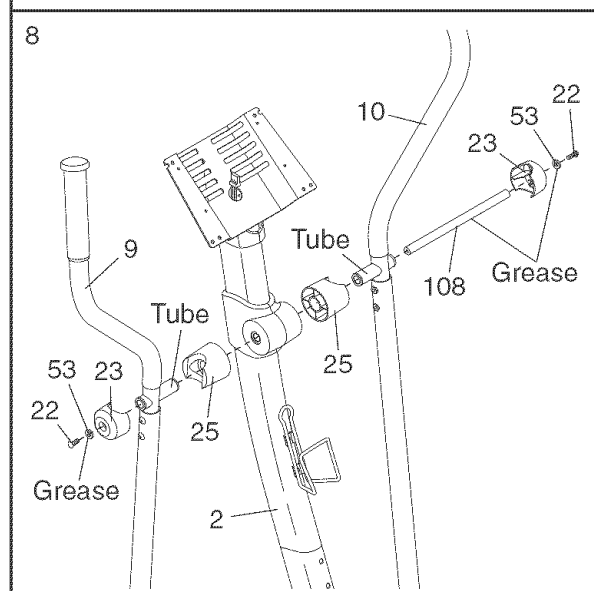

- Remove the Chrome Tube (118) from the left Handlebar Leg (79). Apply a small amount of the included Teflon® lubricant to a paper towel, and rub a thin film of lubricant onto the Chrome Tube. Then, reinsert the Chrome Tube into the Handlebar Leg.

See the drawing at the right and the inset drawing. Apply a thin film of grease to the shaft of a Union Bolt Set (27). Insert the shaft of the Union Bolt Set into the side of the left Flex Bar (14) closest to the Upright (2), and then slide a 4.7mm Spacer (143) onto the shaft. Next, slide the end of the left Chrome Tube (118) onto the shaft and **onto the Spacer**. Then, slide a Wheel Bushing (28), a Ramp Wheel (119), and another Wheel Bushing onto the shaft. **Make sure that all parts are oriented exactly as shown.** Insert the shaft completely through the Flex Bar and tighten the screw of the Union Bolt Set into the shaft.

Repeat this step to attach the right Chrome Tube (118) to the right Flex Bar (14).

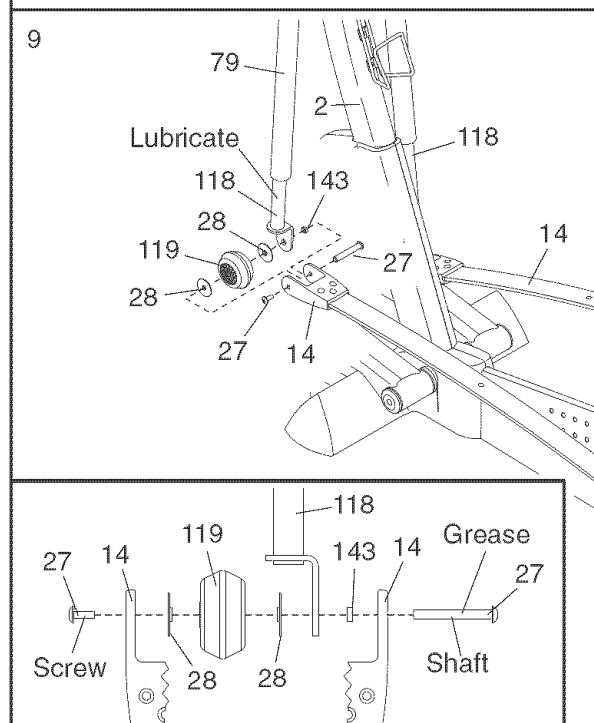

10. Identify the Left Pedal (13). Attach the Left Pedal to the left Flex Bar (14) with an M10 x 35mm Carriage Bolt (20), an M10 Washer (99), and a Pedal Knob (15) as shown. Note: The Left Pedal can be attached in any of five positions (see HOW TO ADJUST THE PEDALS on page 11).

Attach the Right Pedal (12) in the same way. Make sure that both Pedals are in the same position.

See step 7. Tighten the four M8 x 43mm Button Bolts (50).

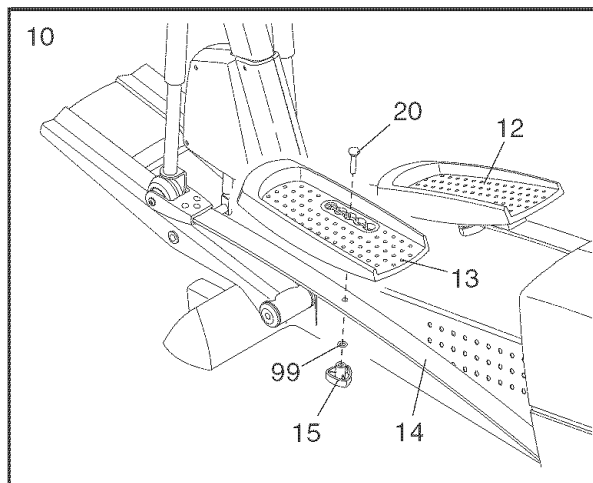

11. Loosen the eight indicated screws (A) in the Center Handlebar (63).

Attach the Center Handlebar (63) to the Upright (2) with eight M6 x 16mm Tapered Button Screws (107). **Do not tighten the Tapered Button Screws yet.**

Retighten the eight screws (A) in the Center Handlebar (63).

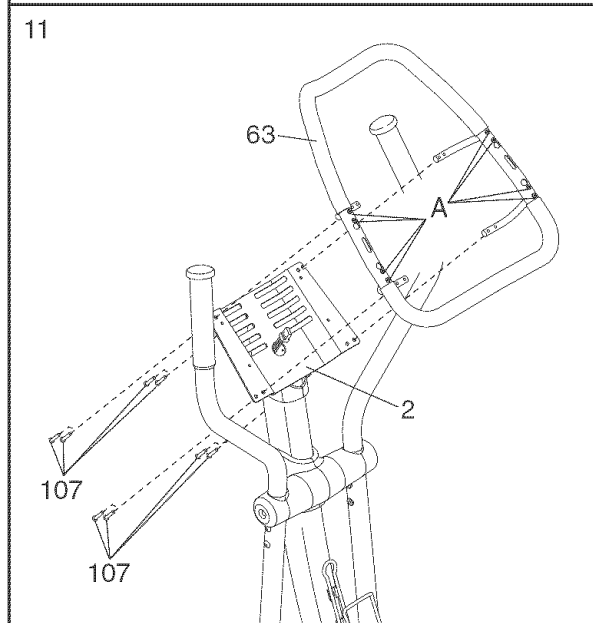

12. See step 13. Remove the six M4 x 16mm Screws (66) and the Left and Right Handlebar Covers (109, 110) from the Console (5).

Attach the CD Holder (114) to the Console (5) with two M4 x 12mm Round Head Screws (18) as shown.

While another person holds the Console (5) in the position shown, connect the wire harness on the Console to the Upper Wire Harness (86). Insert the excess wire harness down into the Upright (2).

Attach the Console (5) to the Upright (2) with four M4 x 16mm Screws (66). **Be careful to avoid pinching the wire harnesses.**

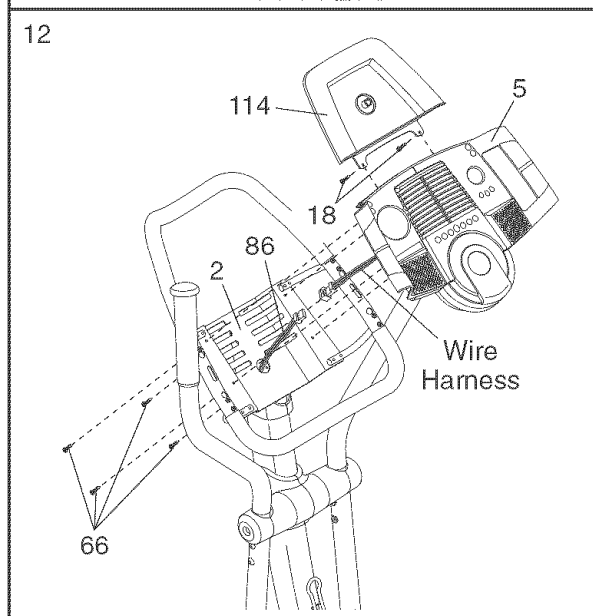

13. Attach the Left Handlebar Cover (109) to the Console (5) with three M4 x 16mm Screws (66). Attach the Right Handlebar Cover (110) in the same way.

See assembly step 11. Tighten the eight M6 x 16mm Tapered Button Screws (107).

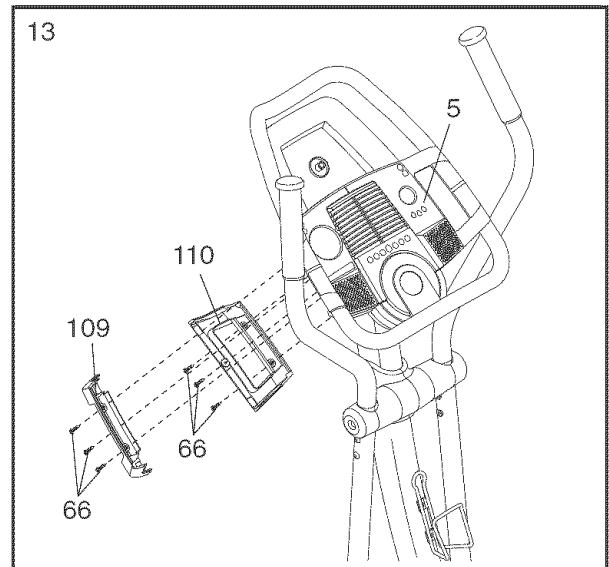

14. Plug the Power Cord (96) into the Power Socket (140) at the rear of the elliptical exerciser.

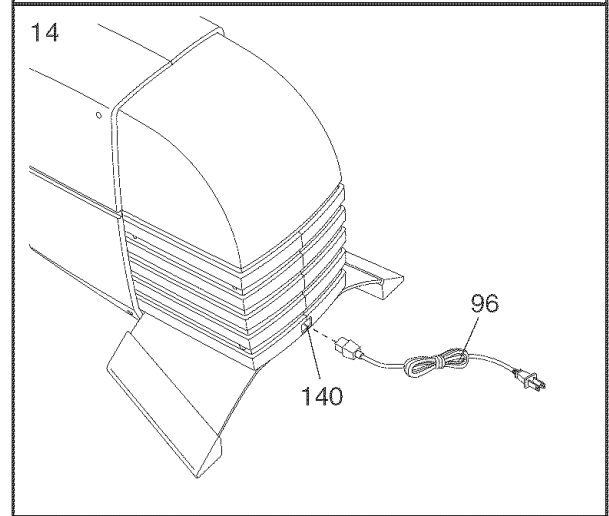

15. **Make sure that all parts of the elliptical exerciser are properly tightened.** Note: Some hardware may be left over after assembly is completed. To protect the floor or carpet from damage, place a mat under the elliptical exerciser.

HOW TO USE THE ELLIPTICAL EXERCISER

HOW TO PLUG IN THE POWER CORD

This product must be grounded. If it should malfunction or break down, grounding provides a path of least resistance for electric current to reduce the risk of electric shock. This product is equipped with a cord having an equipment-grounding conductor and a grounding plug. **Plug the power cord into an appropriate outlet that is properly installed and grounded in accordance with all local codes and ordinances. This product is for use on a nominal 120-volt circuit. Important: The elliptical exerciser is not compatible with GFCI-equipped outlets.**

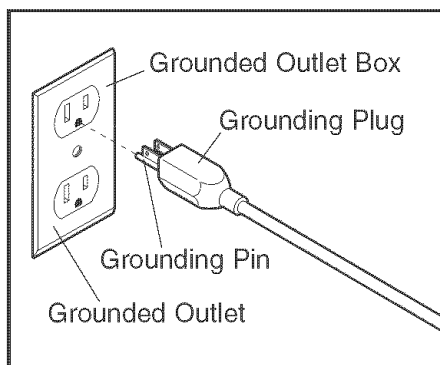

The green-colored rigid ear, lug, or the like extending from the adapter must be connected to a permanent ground such as a properly grounded outlet box cover. Whenever the adapter is used, it must be held in place by a metal screw. **Some 2-pole receptacle outlet box covers are not grounded. Contact a qualified electrician to determine if the outlet box cover is grounded before using an adapter.**

HOW TO ADJUST THE PEDALS

The motion of the pedals is determined by their positions on the flex bars. There are five positions. To adjust each pedal, first loosen the knob beneath the pedal. Next, push the bolt upward, slide the pedal forward or backward to the desired position, and then retighten the knob. Make sure that both pedals are in the same position.

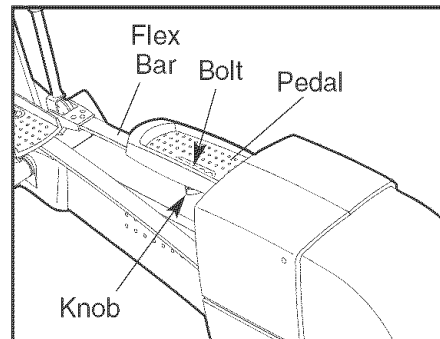

⚠ DANGER: Improper connection of the equipment-grounding conductor can result in an increased risk of electric shock. Check with a qualified electrician or serviceman if you are in doubt as to whether the product is properly grounded. Do not modify the plug provided with the product—if it will not fit the outlet, have a proper outlet installed by a qualified electrician.

HOW TO EXERCISE ON THE ELLIPTICAL EXERCISER

To mount the elliptical exerciser, hold the center handle-bar and step onto the pedal that is in the lowest position. Then, step onto the other pedal. Push the pedals until they begin to move with a continuous motion. **Note: The crank arms (inside of the side shields) can be turned in either direction. It is recommended that you turn the crank arms in the same direction that you pedal a bicycle; however, for variety, you can turn the crank arms in the opposite direction.**

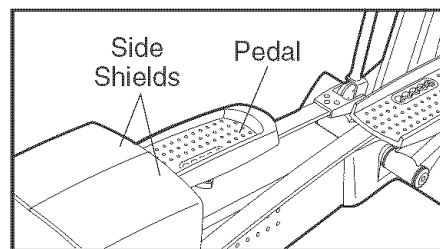

A temporary adapter may be used to connect the power cord to a 2-pole receptacle as shown at the right if a properly grounded outlet is not available. The temporary adapter should be used only until a properly grounded outlet can be installed by a qualified electrician.

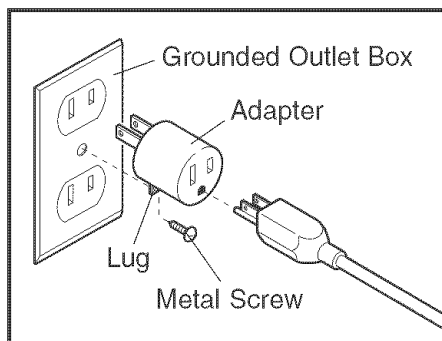

To dismount the elliptical exerciser, wait until the pedals come to a complete stop. **Note: The elliptical exerciser does not have a free wheel; the pedals will continue to move until the flywheel stops.** When the pedals are stationary, step off the highest pedal first. Then, step off the lowest pedal.

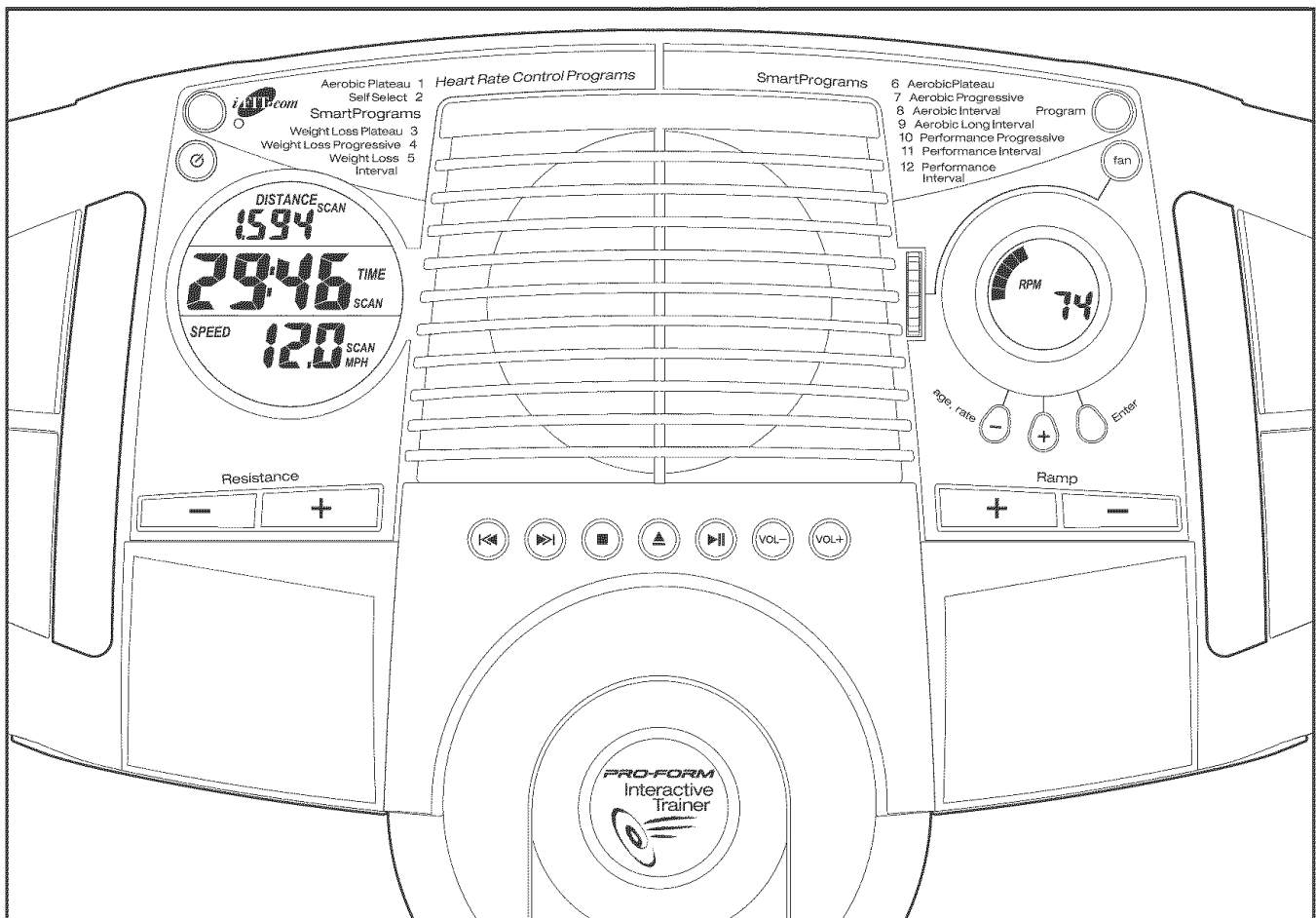

FEATURES OF THE CONSOLE

The advanced console offers a selection of features designed to make your workouts more enjoyable and effective. When the manual mode of the console is selected, the resistance of the pedals and the angle of the ramp can be changed with the touch of a button. As you work out, the console will provide continuous exercise feedback. You can even measure your heart rate using the handgrip pulse sensor.

The console also offers ten Smart programs. Each program automatically changes the resistance of the pedals and prompts you to increase or decrease your pace as it guides you through an effective workout. In addition, the console features two Heart Rate programs that change the resistance of the pedals and prompt you to vary your pace to keep your heart rate near a target heart rate as you exercise.

The console also features iFIT.com interactive technology. Having iFIT.com technology is like having a per-

sonal trainer in your home. Using the built-in CD player, you can play special iFIT.com CD programs. iFIT.com CD programs automatically control the resistance of the pedals and prompt you to vary your pace while a personal trainer coaches you through every step of your workout. High-energy music provides added motivation. **To purchase iFIT.com CDs, call toll-free 1-888-533-1333.**

Using a stereo audio cable (available at electronics stores), you can also connect the elliptical exerciser to your VCR and TV and play iFIT.com video programs. iFIT.com video programs offer the same benefits as iFIT.com CD programs, and allow you to enjoy breathtaking scenery while you exercise. **To purchase iFIT.com videocassettes, call toll-free 1-888-533-1333.**

You can even connect the elliptical exerciser to your home computer, go to our Web site at www.iFIT.com, and access programs directly from our Web site. **Explore www.iFIT.com for more information.**

To use the manual mode of the console, see the instructions below. To use a Smart program, see page 15. To use a Heart Rate program, see page 16. To use an iFIT.com CD program, see page 18. To use an iFIT.com video program, see page 20. To use a program directly from our Web site, see page 21.

HOW TO USE THE MANUAL MODE

1 Turn on the console.

Make sure that the power cord is properly plugged in (see HOW TO PLUG IN THE POWER CORD on page 11).

To turn on the console, press the On/Reset button or begin pedaling. (The On/Reset button is the button just above the large display.)

2 Select the manual mode.

Each time the console is turned on, the manual mode will be selected. If a program has been selected, reselect the manual mode by pressing the Program button repeatedly until the letters RPM appear in the small display.

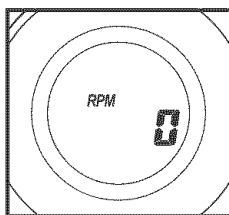

3 Change the resistance of the pedals and the angle of the ramp as desired.

To change the resistance of the pedals, press the Resistance + and – buttons. There are ten resistance levels; level 10 is the most challenging. Note: After the buttons are pressed, it will take a few seconds for the pedals to reach the selected resistance level.

To vary the feel of your exercise on the elliptical exerciser, increase or decrease the angle of the ramp by pressing the Ramp buttons. There are five ramp angles. Note: After the Ramp buttons are pressed, it will take a moment for the ramp to reach the selected angle.

4 Follow your progress with the large display and the small display.

The upper section of the large display will show the distance you have pedaled and the numbers of calories and fat calories you have burned (see FAT BURNING on page 23). The display will change from one number to the next every few seconds. When you use the handgrip pulse sensor, the display will also show your heart rate (see step 5 on page 14).

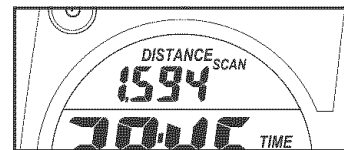

The center of the large display will show the elapsed time and your pedaling pace (in minutes per mile). The display will change from one number to the other every few seconds. Note: When a program is selected (except for Heart Rate program 2), the display will show the time remaining in the program instead of the elapsed time.

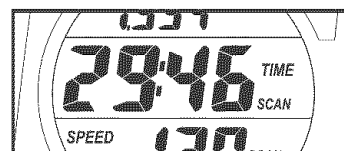

The lower section of the large display will show your pedaling speed, your pedaling pace (in revolutions per minute), and the resistance level. The display will change from one number to the next every few seconds.

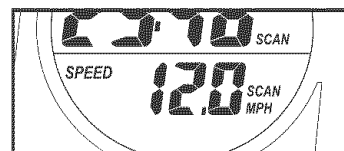

Note: The console can show speed and distance in either miles or kilometers. The letters MPH or KM/H will appear in the lower section of the large display to show which unit of measurement is selected. To change the unit of measurement, first hold down the Program button for a few seconds. An E (for English) or an M (for metric) will appear in the lower section of the large display. Press the Resistance + button to change the unit of measurement. Then, press the On/Reset button.

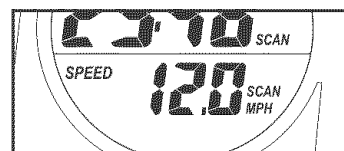

The small display will show your pedaling pace (in revolutions per minute). The indicator bar in the small display will increase or decrease in length as you increase or decrease your pedaling pace. Note: When you use a Heart Rate program, the small display will show your heart rate instead of your pedaling pace.

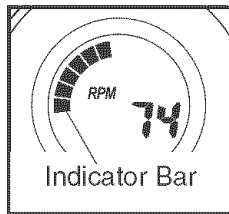

To reset the displays, press the On/Reset button.

5 Measure your heart rate if desired.

If there are thin sheets of plastic on the metal contacts on the hand-grip pulse sensor, peel off the plastic. To use the hand-grip pulse sensor, hold the handgrips with your palms resting against the metal contacts. **Avoid moving your hands or squeezing the handgrips too tightly; excessive movement or pressure may interfere with heart rate readings.** When your pulse is detected, the heart-shaped indicator in the large display will flash each time your heart beats, and your heart rate will be shown.

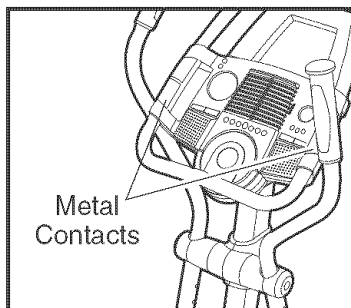

For the most accurate heart rate reading, continue to hold the handgrips for about 30 seconds. Note: When you first hold the handgrips, the large display will show your heart rate continuously for 30 seconds. The display will then show your heart rate along with other feedback modes.

6 Turn on the fan if desired.

To turn on the fan at low speed, press the fan button. To turn on the fan at high speed, press the fan button a second time. To turn off the fan, press the fan button a third time. Note: If the fan is turned on but the pedals are not moved for thirty seconds, the fan will automatically turn off.

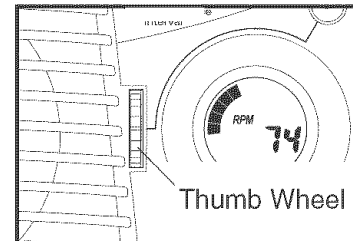

Rotate the thumb wheel on the right side of the fan to pivot the fan to the desired angle.

7 When you are finished exercising, the console will automatically turn off.

If the pedals are not moved for a few seconds, the displays will pause and the time will flash in the large display. If the pedals are not moved and the console buttons are not pressed for a few minutes, the console will turn off.

HOW TO USE A SMART PROGRAM

Each Smart program will automatically change the resistance of the pedals and prompt you to increase or decrease your pace as it guides you through an effective workout. Programs 3, 4, and 5 are weight loss programs; programs 6, 7, 8, and 9 are aerobic programs; and programs 10, 11, and 12 are high-performance programs.

Follow the steps below to use a Smart program.

1 Turn on the console.

See step 1 on page 13.

2 Select one of the Smart programs.

Each time the console is turned on, the manual mode will be selected. To select a Smart program, press the Program button repeatedly until the number 3, 4, 5, 6, 7, 8, 9, 10, 11, or 12 appears in the small display.

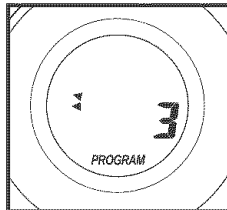

3 Begin pedaling to start the program.

Each Smart program consists of either 20 or 30 one-minute periods. One resistance level and one target pace are programmed for each period. Note: The same resistance level and/or target pace may be programmed for two or more consecutive periods.

When you begin pedaling, the resistance of the pedals will automatically change to the resistance level programmed for the first period. Note: If the resistance level is too high or too low, you can change it by pressing the Resistance buttons.

The target pace for the first period will appear in the small display for a few seconds, and the arrows in the small display will help you to pedal at the target pace—simply increase or decrease

your pace until one segment of the indicator bar appears at the tip of each arrow (see the drawing at the right). Note:

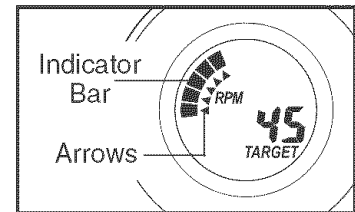

When the word TARGET does not appear in the small display, your actual pedaling pace will be shown.

Important: The target pace is intended only to provide a goal. Your actual pace may be slower than the target pace, especially during the first few months of your exercise program. Make sure to pedal at a pace that is comfortable for you.

During the last three seconds of each period, a series of tones will sound and the time will flash in the large display. The resistance of the pedals will then change if a different resistance level is programmed for the next period. In addition, the number of arrows in the small display will change if a different target pace is programmed for the next period.

During the program, the center of the large display will show the time remaining in the program. If you stop pedaling for a few seconds, the displays will pause and the time will flash. To restart the program, resume pedaling.

4 Follow your progress with the large display.

See step 4 on page 13.

5 Measure your heart rate if desired.

See step 5 on page 14.

6 Turn on the fan if desired.

See step 6 on page 14.

7 When you are finished exercising, the console will automatically turn off.

See step 7 on page 14.

HOW TO USE A HEART RATE PROGRAM

Heart Rate program 1 is designed to keep your heart rate between 65% and 85% of your *maximum heart rate* during your workout. (Your maximum heart rate is estimated by subtracting your age from 220. For example, if you are 25 years old, your maximum heart rate is 195 beats per minute.) Heart Rate program 2 is designed to keep your heart rate near a target heart rate that you select.

Follow the steps below to use a Heart Rate program.

1 Turn on the console.

See step 1 on page 13.

2 Select one of the Heart Rate programs.

Each time the console is turned on, the manual mode will be selected. To select a Heart Rate program, press the Program button repeatedly until the number 1 or 2 appears in the small display.

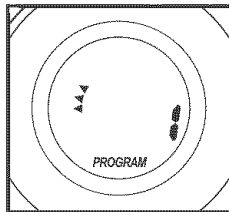

3 Enter your age or a target heart rate.

If **program 1 is selected**, the word AGE and the current age setting will appear in the large display. If you have already entered your age, press the Enter button. If you have not entered your age, press the small + and – buttons to enter your age, and then press the Enter button.

If **program 2 is selected**, the letters PLS and the current target heart rate will appear in the large display. If you do not wish to change the target heart rate, press the Enter button. If you wish to change the target heart rate, press the small + and – buttons, and then press the Enter button.

4 Hold the handgrip pulse sensor.

It is not necessary to hold the handgrip pulse sensor continuously during the program. However, you should hold the handgrips frequently for the program to operate properly. **Each time you hold the handgrips, keep your hands on the metal contacts for at least 30 seconds.**

5 Begin pedaling to start the program.

Heart rate program 1 consists of 20 one-minute periods. One resistance level and one target heart rate are programmed for each period. (Note: The same resistance level and/or target heart rate may be programmed for two or more consecutive periods.) **Heart Rate program 2** is sixty minutes long (you may choose to use only part of the program). The same resistance level and target heart rate are programmed for the entire program.

When you begin pedaling, the resistance of the pedals will automatically change to the resistance level programmed for the first period.

As you pedal, the arrows in the small display will help you to keep your heart rate near the current target heart rate.

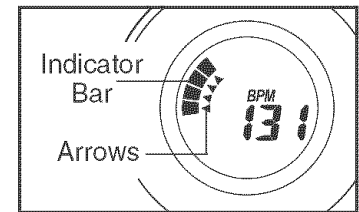

When you hold the handgrip pulse sensor, the console will compare your heart rate to the current target heart rate. If your heart rate is too far above or below the target heart rate, the number of arrows in the small display will change to prompt you to increase or decrease your pace. When the number of arrows changes, change your pace until one segment of the indicator bar appears at the tip of each arrow. **Important: The target pace is intended only to provide a goal. Your actual pace may be slower than the target pace, especially during the first few months of your exercise program. Make sure to pedal at a pace that is comfortable for you.**

During the last three seconds of each period, a series of tones will sound and the time will flash in the large display. The resistance of the pedals will then change if a different resistance level is programmed for the next period. Note: If the resistance level is too high or too low, you can adjust it by pressing the Resistance buttons. However, when the next period begins, the resistance will automatically change if a different resistance level is programmed for the next period.

The program will continue in this way until the large display shows that no time remains in the program. Note: If you stop pedaling for a few seconds, the program will end. To use the program again, reselect it and start it at the beginning.

6 Follow your progress with the large display.

See step 4 on page 13.

7 Turn on the fan if desired.

See step 6 on page 14.

8 When you are finished exercising, the console will automatically turn off.

See step 7 on page 14.

HOW TO USE iFIT.COM CD PROGRAMS

When you use an iFIT.com CD program, a certified personal trainer will guide you through your workout while the program interactively controls the resistance of the pedals and prompts you to increase or decrease your pace. **Note: To purchase iFIT.com CDs, call toll-free 1-888-533-1333.**

Follow the steps below to use an iFIT.com CD program.

1 Turn on the console.

See step 1 on page 13.

2 Select the iFIT.com mode.

Each time the console is turned on, the manual mode will be selected. To use an iFIT.com CD, press the iFIT.com button. The iFIT.com indicator will light and the letters IF will appear in the small display.

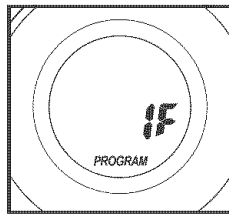

3 Insert an iFIT.com CD into the CD player.

To open the CD player, slide the center button on the CD player upward. Carefully insert an iFIT.com CD into the CD player and then close the lid.

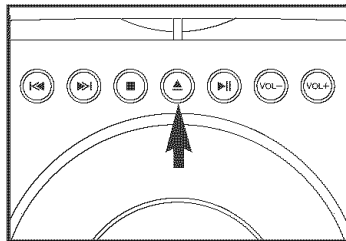

4 Press the Play/Pause button to start the program.

To start the CD program, press the play/pause button on the CD player. A moment after the button is pressed, your personal trainer will begin guiding you through your workout. Simply follow your personal trainer's instructions.

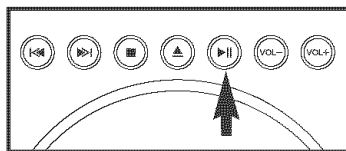

The CD program will function in almost the same way as a Smart program (see step 3 on page 15). However, an electronic "chirping" sound will alert you when the resistance level and/or the target

pace is about to change. **Note: If the resistance level and/or the target pace does not change when a "chirp" is heard, make sure that the iFIT.com indicator is lit. In addition, adjust the volume (see step 5 below). If the volume is too high or too low, the console may not detect the program signals.**

To stop the program at any time, press the play/pause button and stop pedaling. To restart the program, press the play/pause button and begin pedaling.

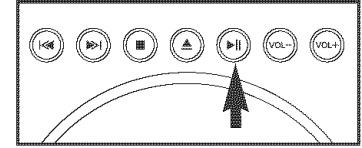

Note: To select a different program on the CD, press the skip/search buttons on the CD player.

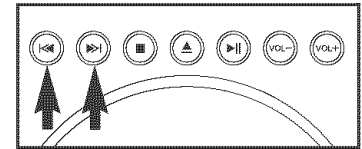

5 Adjust the volume if desired.

To adjust the volume, press the Volume – and + buttons on the CD player.

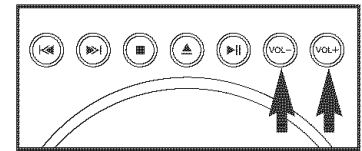

6 Follow your progress with the large display.

See step 4 on page 13.

7 Measure your heart rate if desired.

See step 5 on page 14.

8 Turn on the fan if desired.

See step 6 on page 14.

9 When you are finished exercising, the console will automatically turn off.

See step 7 on page 14.

Note: Always remove iFIT.com CDs from the CD player when you are finished using them.

HOW TO PLAY MUSIC CDS

If desired, you can play your own music CDs in the CD player. Before playing music CDs, select the manual mode of the console (see HOW TO USE THE MANUAL MODE on page 13).

HOW TO CONNECT THE ELLIPTICAL EXERCISER TO YOUR VCR OR COMPUTER

HOW TO CONNECT TO YOUR VCR

Note: If your VCR has an unused AUDIO OUT jack, see instruction A below. If the AUDIO OUT jack is being used, see instruction B. If you have a TV with a built-in VCR, see instruction B.

- A. Plug one end of a 1/8" to RCA stereo audio cable (available at electronics stores) into the jack beneath the console. Plug the other end of the cable into the AUDIO OUT jack on your VCR.

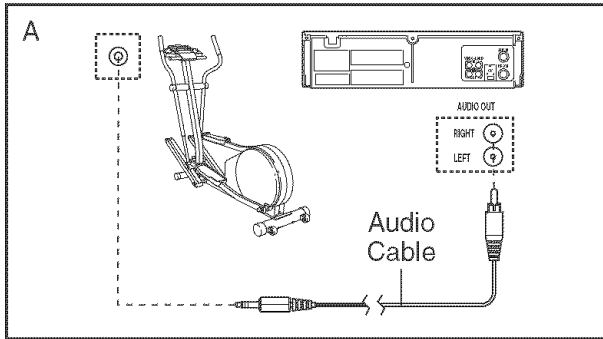

- B. Plug one end of a 1/8" to RCA stereo audio cable (available at electronics stores) into the jack beneath the console. Plug the other end of the cable into an RCA Y-adapter (available at electronics stores). Next, remove the wire that is currently plugged into the AUDIO OUT jack on your VCR and plug the wire into the unused side of the Y-adapter. Plug the Y-adapter into the AUDIO OUT jack on your VCR.

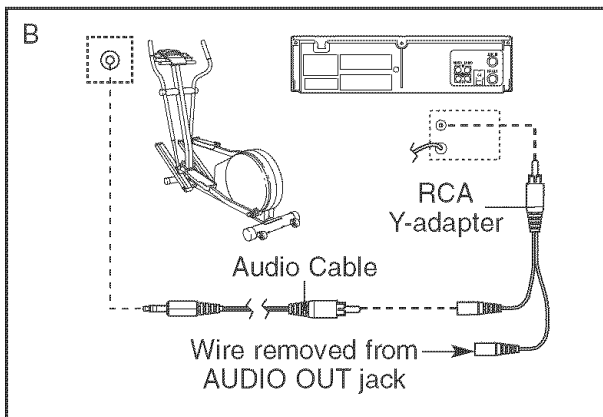

HOW TO CONNECT TO YOUR COMPUTER

Note: If your computer has a 1/8" LINE OUT jack, see instruction A. If your computer has only a PHONES jack, see instruction B.

- A. Plug one end of a 1/8" to 1/8" stereo audio cable (available at electronics stores) into the jack beneath the console. Plug the other end of the cable into the LINE OUT jack on your computer.

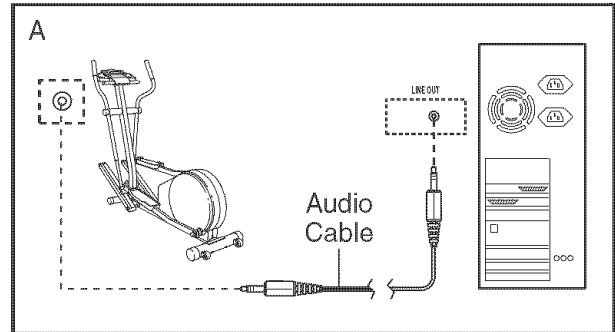

- B. Plug one end of a 1/8" to 1/8" stereo audio cable (available at electronics stores) into the jack beneath the console. Plug the other end of the cable into a 1/8" Y-adapter (available at electronics stores). Plug the Y-adapter into the PHONES jack on your computer. Plug your headphones or speakers into the other side of the Y-adapter.

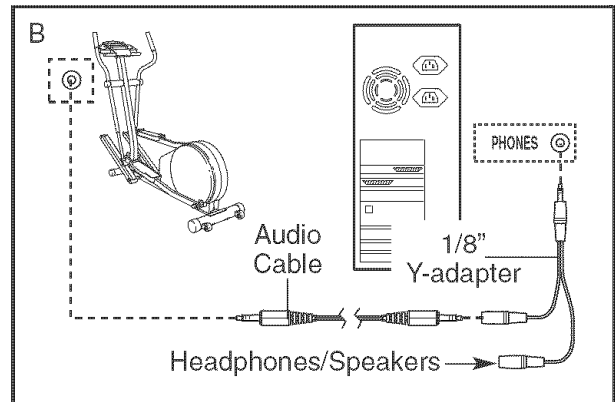

HOW TO USE iFIT.COM VIDEO PROGRAMS

To use iFIT.com videocassettes, the elliptical exerciser must be connected to your VCR. See HOW TO CONNECT TO YOUR VCR on page 19. **To purchase iFIT.com videocassettes, call toll-free 1-888-533-1333.**

Follow the steps below to use an iFIT.com video program.

1 Turn on the console.

See step 1 on page 13.

2 Select the iFIT.com mode.

Each time the console is turned on, the manual mode will be selected. To use an iFIT.com videocassette, press the iFIT.com button. The iFIT.com indicator will light and the letters IF will appear in the small display.

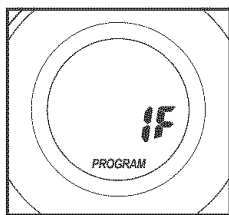

3 Insert the iFIT.com videocassette.

Insert the videocassette into your VCR.

4 Press the play button on your VCR.

A moment after the play button is pressed, your personal trainer will begin guiding you through your workout. Simply follow your personal trainer's instructions.

The video program will function in almost the same way as a Smart program (see step 3 on page 15). However, an electronic "chirping" sound will alert you when the resistance level and/or the target pace is about to change.

Note: If the resistance level and/or the target pace does not change when a "chirp" is heard:

- **Make sure that the iFIT.com indicator is lit.**
- **Adjust the volume of your VCR. If the volume is too high or too low, the console may not detect the program signals.**
- **Make sure that the audio cable is properly connected and that it is fully plugged in.**

To stop the program at any time, stop pedaling and press the pause button on your VCR. To restart the program, press the play button on your VCR and begin pedaling.

5 Follow your progress with the large display.

See step 4 on page 13.

6 Measure your heart rate if desired.

See step 5 on page 14.

7 Turn on the fan if desired.

See step 6 on page 14.

8 When you are finished exercising, the console will automatically turn off.

See step 7 on page 14.

HOW TO USE PROGRAMS DIRECTLY FROM OUR WEB SITE

Our Web site at www.iFIT.com allows you to play iFIT.com programs directly from the internet. To use programs from our Web site, the elliptical exerciser must be connected to your computer. See HOW TO CONNECT TO YOUR COMPUTER on page 19. In addition, you must have an internet connection and an internet service provider. A list of specific system requirements is found on our Web site.

Follow the steps below to use a program from our Web site.

1 Turn on the console.

See step 1 on page 13.

2 Select the iFIT.com mode.

Each time the console is turned on, the manual mode will be selected. To use a program from our Web site, press the iFIT.com button. The iFIT.com indicator will light and the letters IF will appear in the small display.

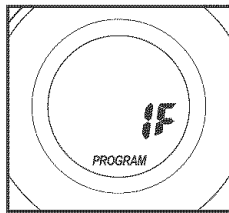

3 Go to your computer and start an internet connection.

4 Start your Web browser, if necessary, and go to our Web site at www.iFIT.com.

5 Follow the desired links on our Web site to select a program.

6 Follow the on-line instructions to start the program.

When you start the program, an on-screen countdown will begin.

7 Return to the elliptical exerciser and begin pedaling.

When the on-screen countdown ends, the program will begin. The program will function in almost the same way as a Smart program (see step 3 on page 15). However, an electronic “chirping” sound will alert you when the resistance level and/or the target pace is about to change.

8 Follow your progress with the large display.

See step 4 on page 13.

9 Measure your heart rate if desired.

See step 5 on page 14.

10 Turn on the fan if desired.

See step 6 on page 14.

11 When you are finished exercising, the console will automatically turn off.

See step 7 on page 14.

MAINTENANCE AND TROUBLESHOOTING

Inspect and properly tighten all parts of the elliptical exerciser regularly. Replace any worn parts immediately.

For smooth operation of the elliptical exerciser, **inspect and clean the ramp regularly** using a soft cloth and mild detergent. Other parts of the elliptical exerciser can also be cleaned in this way. **Keep liquids off the console. Never use abrasives or solvents.**

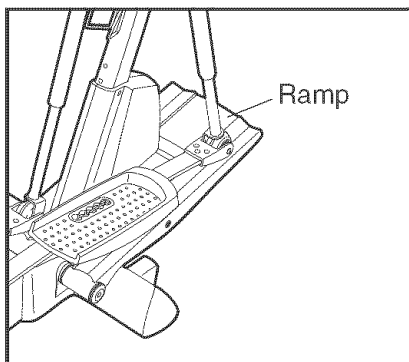

PULSE SENSOR TROUBLESHOOTING

If the handgrip pulse sensor does not function properly, see step 5 on page 14.

HOW TO LEVEL THE ELLIPTICAL EXERCISER

If the elliptical exerciser rocks during use, turn one or both of the leveling feet under the front stabilizer until the rocking motion is eliminated.

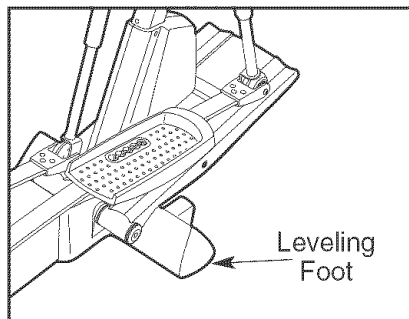

HOW TO MOVE THE ELLIPTICAL EXERCISER

Stand in front of the elliptical exerciser, hold the handlebars firmly, and place one foot against the ramp in the location shown below. Pull the handlebars until the elliptical exerciser can be moved on the front wheels, and carefully move the elliptical exerciser to the desired location. Then, place one foot against the ramp, and lower the elliptical exerciser. **Due to the size and weight of the elliptical exerciser, use extreme caution while moving and lowering it.**

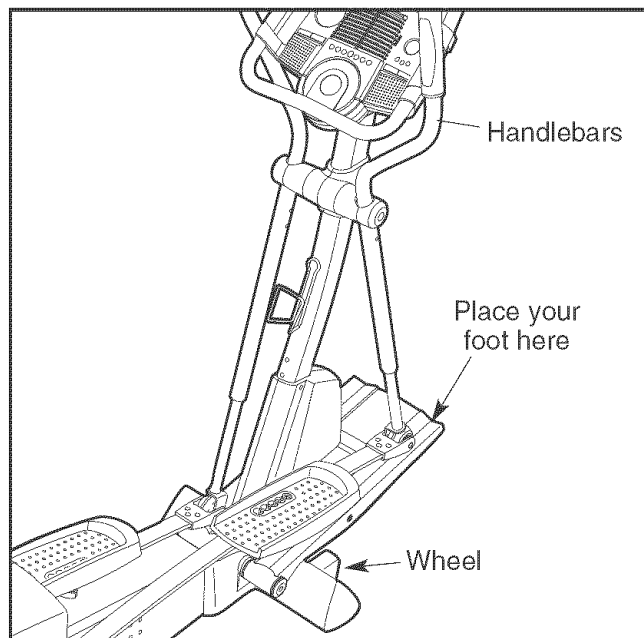

CD PLAYER TROUBLESHOOTING

If the CD player stops working or fails to respond, unplug the power cord and then plug it back in.

CONDITIONING GUIDELINES



WARNING:

- Before beginning this or any exercise program, consult your physician. This is especially important for persons over the age of 35 or persons with pre-existing health problems.
- The pulse sensor is not a medical device. Various factors may affect the accuracy of heart rate readings. The pulse sensor is intended only as an exercise aid in determining heart rate trends in general.

The following guidelines will help you to plan your exercise program. Remember that proper nutrition and adequate rest are essential for successful results.

EXERCISE INTENSITY

Whether your goal is to burn fat or to strengthen your cardiovascular system, the key to achieving the desired results is to exercise with the proper intensity. The proper intensity level can be found by using your heart rate as a guide. The chart below shows recommended heart rates for fat burning, maximum fat burning, and cardiovascular (aerobic) exercise.

165	155	145	140	130	125	115	
145	138	130	125	118	110	103	
125	120	115	110	105	95	90	
<hr/>							
20	30	40	50	60	70	80	

To find the proper heart rate for you, first find your age at the bottom of the chart (ages are rounded off to the nearest ten years). Next, find the three numbers above your age. The three numbers are your “training zone.” The lower two numbers are recommended heart rates for fat burning; the highest number is the recommended heart rate for aerobic exercise.

Fat Burning

To burn fat effectively, you must exercise at a relatively low intensity level for a sustained period of time.

During the first few minutes of exercise, your body uses easily accessible *carbohydrate* calories for energy. Only after the first few minutes of exercise does your body begin to use stored *fat* calories for energy. If your goal is to burn fat, adjust the intensity of your exercise until your heart rate is near the lowest number in your training zone as you exercise.

For maximum fat burning, adjust the intensity of your exercise until your heart rate is near the middle number in your training zone as you exercise.

Aerobic Exercise

If your goal is to strengthen your cardiovascular system, your exercise must be “aerobic.” Aerobic exercise is activity that requires large amounts of oxygen for prolonged periods of time. This increases the demand on the heart to pump blood to the muscles, and on the lungs to oxygenate the blood. For aerobic exercise, adjust the intensity of your exercise until your heart rate is near the highest number in your training zone as you exercise.

WORKOUT GUIDELINES

Each workout should include the following three parts:

A warm-up, consisting of 5 to 10 minutes of stretching and light exercise. A proper warm-up increases your body temperature, heart rate, and circulation in preparation for exercise.

Training zone exercise, consisting of 20 to 30 minutes of exercising with your heart rate in your training zone. Note: During the first few weeks of your exercise program, do not keep your heart rate in your training zone for longer than 20 minutes.

A cool-down, with 5 to 10 minutes of stretching. This will increase the flexibility of your muscles and will help to prevent post-exercise problems.

EXERCISE FREQUENCY

To maintain or improve your condition, complete three workouts each week, with at least one day of rest between workouts. After a few months of regular exercise, you may complete up to five workouts each week if desired. The key to success is to make exercise a regular and enjoyable part of your everyday life.

PART LIST—Model No. PFEL13031

R0204A

Key No.	Qty.	Description	Key No.	Qty.	Description
1	1	Frame	53	2	M8.5 Small Washer
2	1	Upright	54	1	"C" Magnet
3	1	Front Stabilizer	55	1	Motor
4	1	Rear Stabilizer	56	1	Belt
5	1	Console	57	2	M4 x 5mm Screw
6	1	Left Side Shield	58	4	M6 Washer
7	1	Right Side Shield	59	15	M6 Nylon Locknut
8	1	Rear Left Side Shield	60	2	M6 Nut
9	1	Left Handlebar	61	4	M5 Nylon Locknut
10	1	Right Handlebar	62	4	M5 x 14mm Bolt
11	2	Foam Grip	63	1	Center Handlebar
12	1	Right Pedal	64	4	M6 x 32mm Button Screw
13	1	Left Pedal	65	2	M8.5 Large Washer
14	2	Flex Bar	66	21	M4 x 16mm Screw
15	2	Pedal Knob	67	6	M6 x 18mm Patch Screw
16	1	Left Flex Bracket	68	1	Right Rear Side Shield
17	2	Front Flex Bracket	69	1	Reed Switch Clamp
18	3	M4 x 12mm Round Head Screw	70	2	M8 x 38mm Button Screw
19	6	M6 x 26mm Flat Screw	71	2	Handlebar Grip
20	2	M10 x 35mm Carriage Bolt	72	3	Leveling Foot
21	2	Snap Ring	73	3	M5 x 16mm Screw
22	2	M8 x 19mm Shoulder Screw	74	3	M4 x 25mm Round Head Screw
23	2	Handlebar Cap	75	1	Left Inner Shield
24	6	Handlebar Bushing	76	1	Spring
25	2	Handlebar Spacer	77	1	Reed Switch
26	1	Left Handlebar Cover	78	1	Reed Switch Bracket
27	2	Union Bolt Set	79	2	Handlebar Leg
28	4	Wheel Bushing	80	1	Side Shield Cover
29	1	Right Handlebar Cover	81	1	Right Inner Shield
30	1	Center Cover	82	1	Right Flex Bracket
31	1	Left Stabilizer Cover	83	1	Large Frame Spacer
32	2	Wheel	84	16	M4 x 12mm Tap Screw
33	6	M8 x 54mm Button Screw	85	1	Adjustment Cable Assembly
34	1	Left Upright Cover	86	1	Upper Wire Harness
35	1	Left Stabilizer Endcap	87	1	Lower Wire Harness
36	1	Left Crank Arm	88	2	Flex Bracket Spacer
37	1	Pulley	89	2	M8 x 25mm Button Screw
38	1	Right Upright Cover	90	4	Motor Washer
39	1	Crank	91	1	Water Bottle Holder
40	2	Crank Bearing	92	1	Right Stabilizer Endcap
41	1	Flywheel	93	2	M4 x 14mm Round Head Screw
42	2	Flywheel Bearing	94	10	M8 Split Washer
43	1	Magnet	95	1	Front Plate
44	1	Flywheel Axle	96	1	Power Cord
45	5	M4 x 16mm Round Head Screw	97	1	Idler Assembly
46	8	M8 Nylon Locknut	98	3	M4 x 52mm Screw
47	2	Crank Screw	99	2	M10 Washer
48	1	Right Crank Arm	100	2	Small Spacer
49	1	M6 x 38mm Bolt	101	2	Large Spacer
50	4	M8 x 43mm Button Bolt	102	4	M8 x 45mm Button Screw
51	1	M6 x 18mm Bolt	103	1	Alignment Rod
52	1	"C" Magnet Bracket	104	2	M6 Nut

Key No.	Qty.	Description	Key No.	Qty.	Description
105	1	Idler Bolt	127	2	M8 x 48mm Button Bolt
106	1	Idler Adjustment Screw	128	1	Ramp Axle
107	8	M6 x 16mm Tapered Button Screw	129	2	Frame Bushing
108	1	Pivot Axle	130	2	Ramp Spacer
109	1	Left Handlebar Cover	131	4	Ramp Bushing
110	1	Right Handlebar Cover	132	2	Ramp Axle Cover
111	7	M4 x 14mm Screw	133	1	Ramp
112	2	M6 x 30mm Flat Bolt	134	1	Ramp Cover
113	1	Rear Plate	135	4	#8 x 9.5mm Screw
114	1	CD Holder	136	1	Control Box Cover
115	2	M8 x 43mm Button Screw	137	1	Incline Axle
116	1	Right Stabilizer Cover	138	1	Left Motor Cover
117	2	Handlebar Leg Bushing	139	1	Right Motor Cover
118	2	Chrome Tube	140	1	Power Socket
119	2	Ramp Wheel	141	1	Control Box
120	1	Incline Motor	142	1	Control Board
121	1	Incline Sensor	143	2	4.7mm Spacer
122	1	Sensor Cover	#	6	Allen Wrench
123	2	Incline Spacer	#	1	Grease
124	1	Stop Bracket	#	1	Teflon® Lubricant
125	1	Incline Motor Bracket	#	1	User's Manual
126	1	Incline Bolt Set			

Note: “#” indicates a non-illustrated part. Specifications are subject to change without notice. See the back cover of this manual for information about ordering replacement parts.

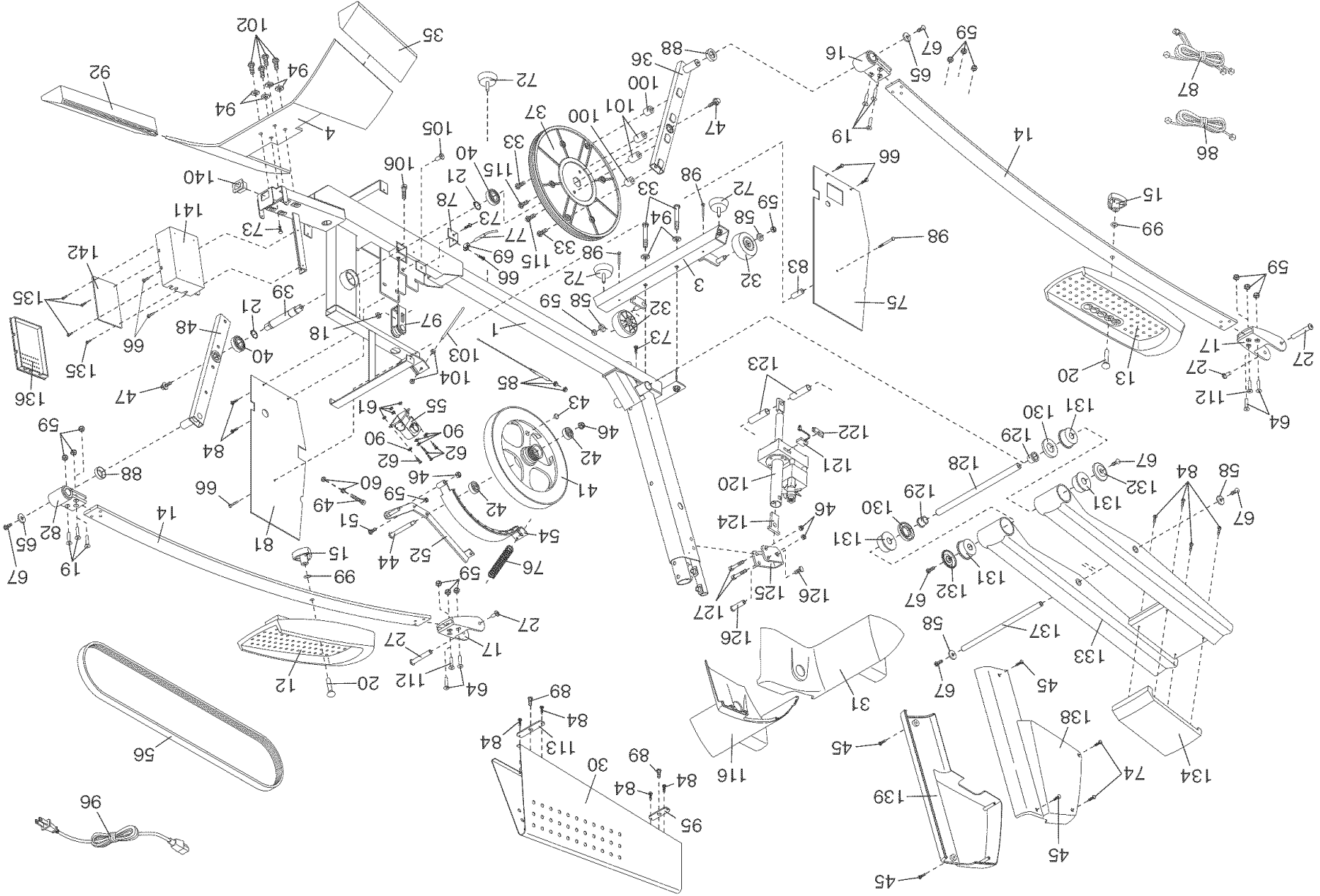

HOW TO ORDER REPLACEMENT PARTS

To order replacement parts, simply call our Customer Service Department toll-free at 1-888-533-1333, Monday through Friday, 6 a.m. until 6 p.m. Mountain Time (excluding holidays). To help us assist you, please be prepared to give the following information when calling:

- The MODEL NUMBER of the product (PFEL13031)
- The NAME of the product (PROFORM® 1280 S elliptical exerciser)
- The SERIAL NUMBER of the product (see the front cover of this manual)
- The KEY NUMBER and DESCRIPTION of the part(s) (see pages 24 and 25)

LIMITED WARRANTY

ICON Health & Fitness, Inc. (ICON), warrants this product to be free from defects in workmanship and material, under normal use and service conditions, for a period of ninety (90) days from the date of purchase. This warranty extends only to the original purchaser. ICON's obligation under this warranty is limited to replacing or repairing, at ICON's option, the product through one of its authorized service centers. All repairs for which warranty claims are made must be pre-authorized by ICON. This warranty does not extend to any product or damage to a product caused by or attributable to freight damage, abuse, misuse, improper or abnormal usage or repairs not provided by an ICON authorized service center; products used for commercial or rental purposes; or products used as store display models. No other warranty beyond that specifically set forth above is authorized by ICON.

ICON is not responsible or liable for indirect, special or consequential damages arising out of or in connection with the use or performance of the product or damages with respect to any economic loss, loss of property, loss of revenues or profits, loss of enjoyment or use, costs of removal or installation or other consequential damages of whatsoever nature. Some states do not allow the exclusion or limitation of incidental or consequential damages. Accordingly, the above limitation may not apply to you.

The warranty extended hereunder is in lieu of any and all other warranties and any implied warranties of merchantability or fitness for a particular purpose is limited in its scope and duration to the terms set forth herein. Some states do not allow limitations on how long an implied warranty lasts. Accordingly, the above limitation may not apply to you.

This warranty gives you specific legal rights. You may also have other rights which vary from state to state.

ICON HEALTH & FITNESS, INC., 1500 S. 1000 W., LOGAN, UT 84321-9813