

# N O R D I C T R A C K<sup>®</sup>

## C2420

Patent Pending

Model No. NTL14950

Serial No. \_\_\_\_\_

Find the serial number in the location shown below. Write the serial number in the space above for reference.

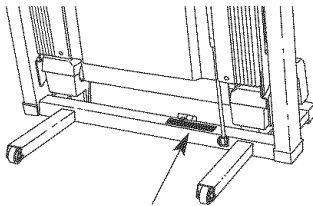

Serial Number Decal

## QUESTIONS?

If you have questions, or if there are missing parts, we will guarantee complete satisfaction through direct assistance from our factory.

**TO AVOID DELAYS, PLEASE CALL DIRECT TO OUR TOLL-FREE CUSTOMER HOT LINE.** The trained technicians on our Customer Hot Line will provide immediate assistance, free of charge to you.

CUSTOMER HOT LINE:

**1-888-825-2588**

Mon.-Fri., 6 a.m.-6 p.m. MST

## CAUTION

Read all precautions and instructions in this manual before using this equipment. Save this manual for future reference.

## USER'S MANUAL

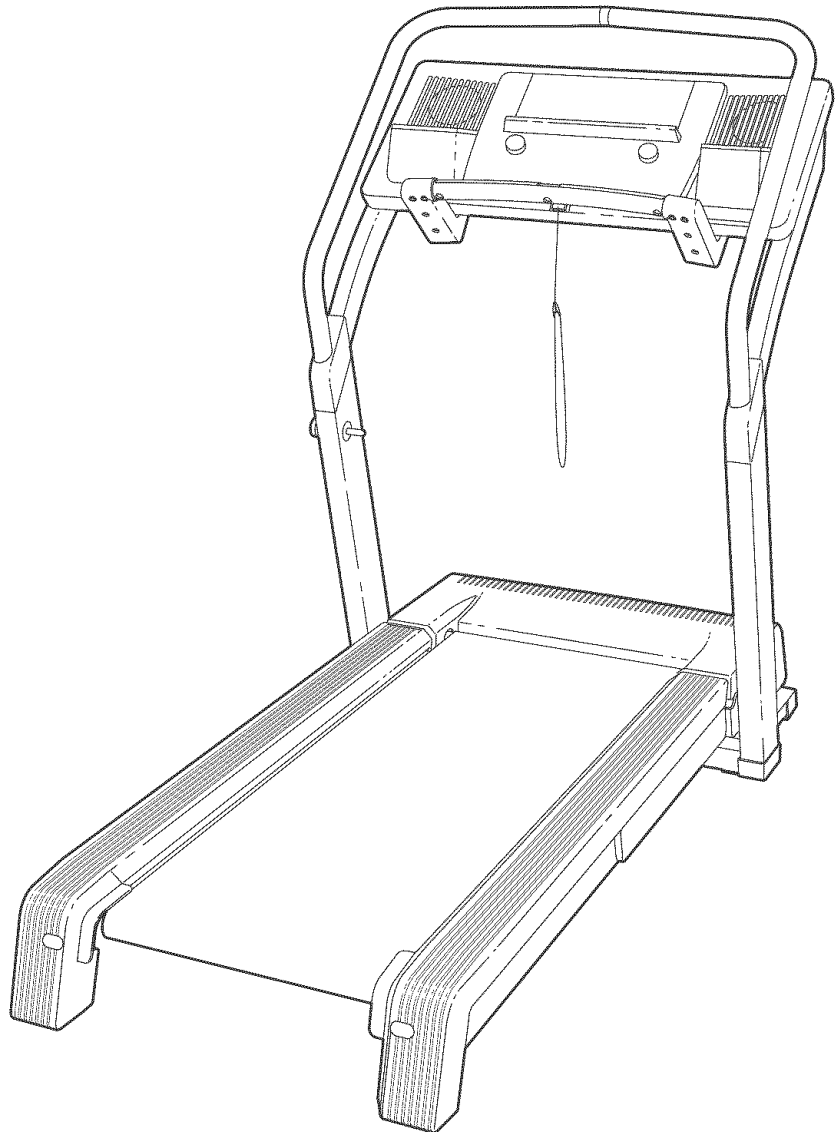

Visit our website at

[www.nordictrack.com](http://www.nordictrack.com)

new products, prizes,  
fitness tips, and much more!

# N O R D I C T R A C K<sup>®</sup>



# C2420

---

## TABLE OF CONTENTS

IMPORTANT PRECAUTIONS .....	3
BEFORE YOU BEGIN .....	5
ASSEMBLY .....	6
OPERATION AND ADJUSTMENT .....	11
HOW TO FOLD AND MOVE THE TREADMILL .....	28
TROUBLESHOOTING .....	30
CONDITIONING GUIDELINES .....	32
PART LIST .....	34
ORDERING REPLACEMENT PARTS .....	35
LIMITED WARRANTY .....	Back Cover

Note: An EXPLODED DRAWING is attached in the center of this manual.

# IMPORTANT PRECAUTIONS

**▲ WARNING:** To reduce the risk of burns, fire, electric shock, or injury to persons, read the following important precautions and information before operating the treadmill.

1. It is the responsibility of the owner to ensure that all users of this treadmill are adequately informed of all warnings and precautions.
2. Use the treadmill only as described.
3. Place the treadmill on a level surface, with at least eight feet of clearance behind it and two feet on each side. Do not place the treadmill on any surface that blocks air openings. To protect the floor or carpet from damage, place a mat under the treadmill.
4. Keep the treadmill indoors, away from moisture and dust. Do not put the treadmill in a garage or covered patio, or near water.
5. Do not operate the treadmill where aerosol products are used or where oxygen is being administered.
6. Keep children under the age of 12 and pets away from the treadmill at all times.
7. The treadmill should not be used by persons weighing more than 350 pounds.
8. Never allow more than one person on the treadmill at a time.
9. Wear appropriate exercise clothes when using the treadmill. Do not wear loose clothes that could become caught in the treadmill. Athletic support clothes are recommended for both men and women. *Always wear athletic shoes. Never use the treadmill with bare feet, wearing only stockings, or in sandals.*
10. When connecting the power cord (see page 11), plug the power cord into a surge suppressor (not included) and plug the surge suppressor into a grounded circuit capable of carrying 15 or more amps. No other appliance should be on the same circuit. Do not use an extension cord.
11. Use only a single-outlet surge suppressor that meets all of the specifications described on page 11. To purchase a surge suppressor, see your local NordicTrack dealer or call 1-888-825-2588 and order part number 146148, or see your local electronics store.
12. Failure to use a properly functioning surge suppressor could result in damage to the control system of the treadmill. If the control system is damaged, the walking belt may change speed, accelerate, or stop unexpectedly, which may result in a fall and serious injury.
13. Keep the power cord and the surge suppressor away from heated surfaces.
14. Never move the walking belt while the power is turned off. Do not operate the treadmill if the power cord or plug is damaged, or if the treadmill is not working properly. (See **BEFORE YOU BEGIN** on page 5 if the treadmill is not working properly.)
15. Never start the treadmill while you are standing on the walking belt. Always hold the handrails while using the treadmill.
16. The treadmill is capable of high speeds. Adjust the speed in small increments to avoid sudden jumps in speed.
17. The pulse sensor is not a medical device. Various factors, including the user's movement, may affect the accuracy of heart rate readings. The pulse sensor is intended only as an exercise aid in determining heart rate trends in general.
18. Never leave the treadmill unattended while it is running. Always remove the key, unplug the power cord, and switch the reset/off circuit breaker to the off position when the treadmill is not in use. (See the drawing on page 5 for the location of the reset/off circuit breaker.)
19. Do not attempt to raise, lower, or move the treadmill until it is properly assembled. (See **ASSEMBLY** on page 6, and **HOW TO FOLD AND MOVE THE TREADMILL** on page 28.) You must be able to safely lift 55 pounds (25 kg) to raise, lower, or move the treadmill.
20. Do not change the incline of the treadmill by placing objects under the treadmill.
21. When folding or moving the treadmill, make sure that the storage latch is fully closed.

22. When using iFIT.com CDs and videos, an electronic “chirping” sound will alert you when the speed and/or incline of the treadmill is about to change. Always listen for the “chirp” and be prepared for speed and/or incline changes. In some instances, the speed and/or incline may change before the personal trainer describes the change.

23. When using iFIT.com CDs and videos, you can manually override the speed and incline settings by pressing the speed and incline buttons. However, when the next “chirp” is heard, the speed and/or incline will change to the next settings of the CD or video program.

24. Always remove iFIT.com CDs and videos from your CD player or VCR and disconnect your MP3 player when you are not using them.

25. Inspect and properly tighten all parts of the treadmill regularly.

26. Never insert or drop any object into any opening.

27. **DANGER:** Always unplug the power cord immediately after use, before cleaning the treadmill, and before performing the maintenance and adjustment procedures described in this manual. Never remove the motor hood unless instructed to do so by an authorized service representative. Servicing other than the procedures in this manual should be performed by an authorized service representative only.

28. The treadmill is intended for in-home use only. Do not use the treadmill in any commercial, rental, or institutional setting.



**⚠ WARNING:** Before beginning this or any exercise program, consult your physician. This is especially important for persons over the age of 35 or persons with pre-existing health problems. Read all instructions before using. ICON assumes no responsibility for personal injury or property damage sustained by or through the use of this product.

## SAVE THESE INSTRUCTIONS

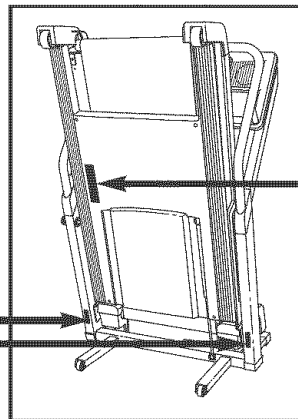
The decals shown here have been placed on your treadmill. If a decal is missing or illegible, please call our Customer Service Department, toll-free, to order a free replacement decal (see ORDERING REPLACEMENT PARTS on page 35). Apply the decal in the location shown. Note: The decals may not be shown at actual size.



**⚠ WARNING:**  
Protect yourself and others from risk of serious injury. Read the user's manual and:

-  •Stand only on the side rails when starting or stopping treadmill.
- Change speed in small increments.
- Hold handrails to prevent falling, and always wear the safety clip while operating treadmill.
- Stop if you feel faint, dizzy, or short of breath.
- Fully engage storage latch before treadmill is moved or stored.
- Reduce incline to its lowest level before folding treadmill into storage position.
-  •Never allow children on or around treadmill.
- Remove key when not in use.
-  •Keep clothing, fingers, and hair away from moving belt.
- Never try to adjust or fix the belt while it is moving.
- Always wear athletic shoes while operating treadmill.

# BEFORE YOU BEGIN

Thank you for selecting the revolutionary NordicTrack® C2420 treadmill. The C2420 treadmill offers a selection of features designed to make your workouts at home more enjoyable and effective. And when you're not exercising, the unique C2420 treadmill can be folded up, requiring less than half the floor space of other treadmills.

**For your benefit, read this manual carefully before using the treadmill.** If you have questions after reading this manual, please call our Customer Service

Department toll-free at 1-888-825-2588, Monday through Friday, 6 a.m. until 6 p.m. Mountain Time (excluding holidays). To help us assist you, please note the product model number and serial number before calling. The model number of the treadmill is NTL14950. The serial number can be found on a decal attached to the treadmill (see the front cover of this manual for the location).

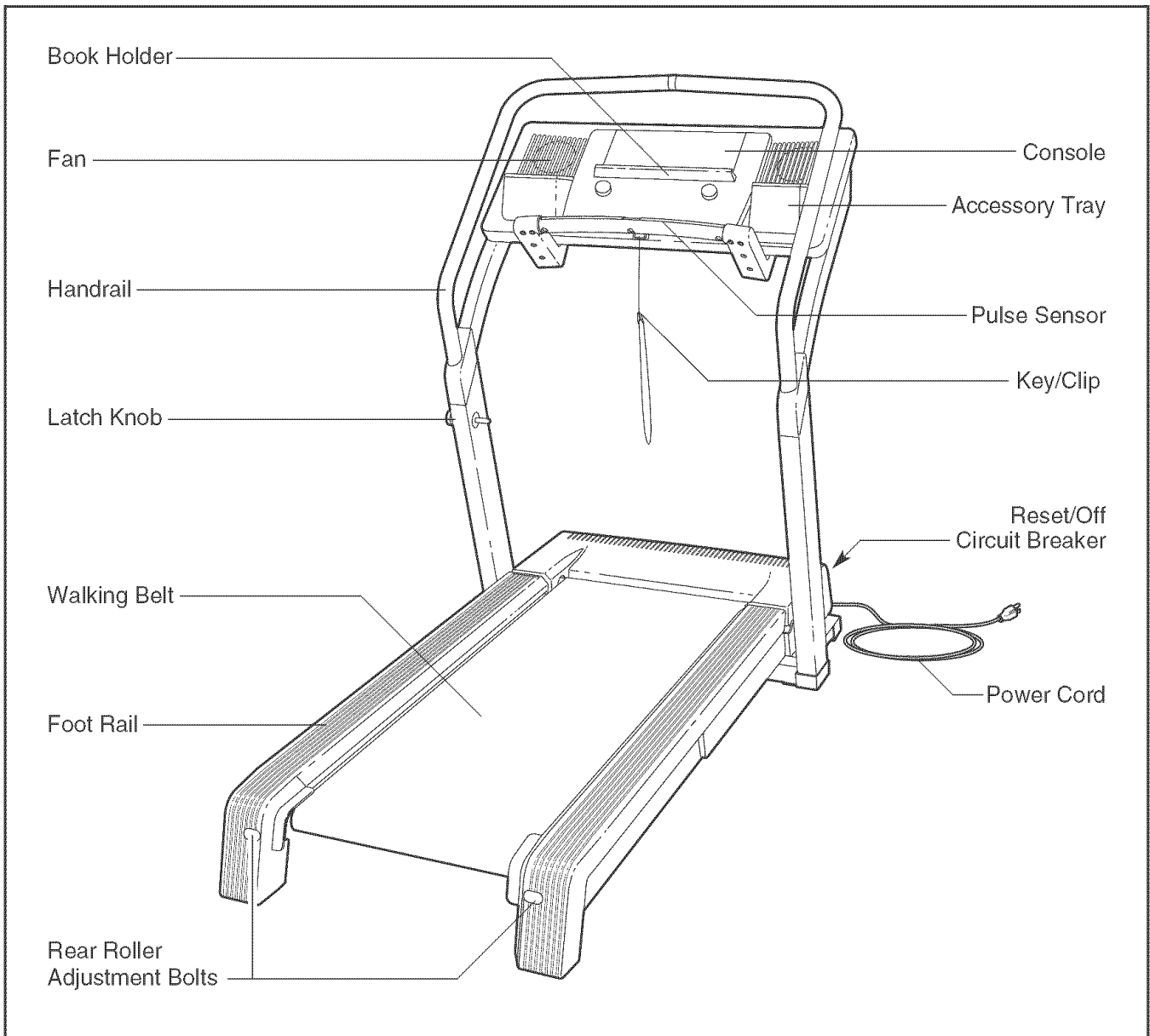

Before reading further, please familiarize yourself with the parts that are labeled in the drawing below.



# ASSEMBLY

**Assembly requires two persons.** Set the treadmill in a cleared area and remove all packing materials. **Do not dispose of the packing materials until assembly is completed.**

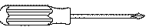
Note: The underside of the treadmill walking belt is coated with high-performance lubricant. During shipping, a small amount of lubricant may be transferred to the top of the walking belt or the shipping carton. This is a normal condition and does not affect treadmill performance. If there is lubricant on top of the walking belt, simply wipe off the lubricant with a soft cloth and a mild, non-abrasive cleaner.

Assembly requires the included allen wrench  and your own phillips screwdriver  and wire cutters . For help identifying the assembly hardware, see the hardware drawings below.

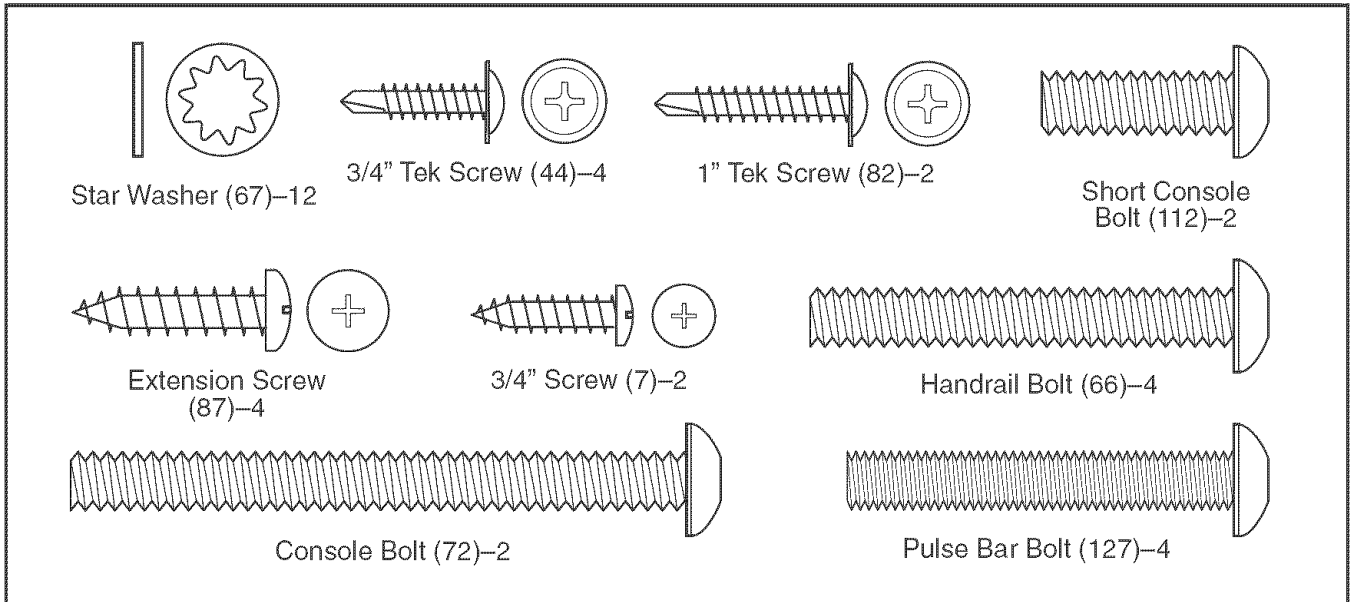

1. **Open parts bag A.** With the help of a second person, carefully raise the Uprights (85) and the Frame (55) to the position shown.

While the other person holds the Uprights (85) and the Frame (55), slide the two Base Extensions (90) onto the two brackets on the base of the Uprights. Make sure that the Base Extensions are turned so the Base Pads (81) are beneath it. Note: It may be helpful to tip the Uprights forward as you insert the Base Extensions.

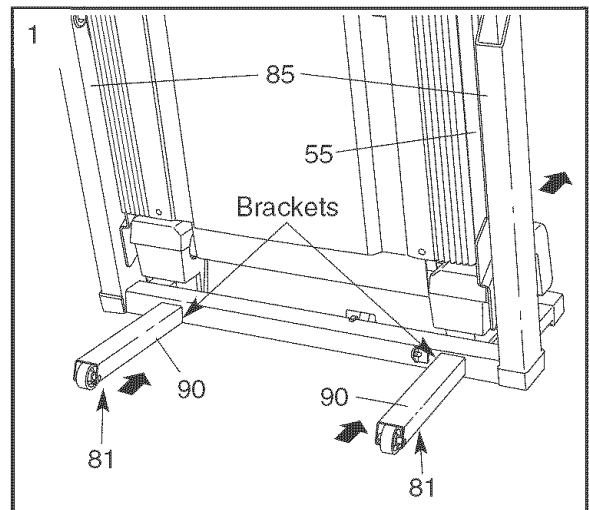

2. With the help of a second person, carefully tip the Frame (55) and the Uprights (85) down to the position shown. **Make sure that the Base Extensions (90) remains in place.**

Carefully slide the Base Cover (92) onto the base of the Uprights (85). Attach the Base Cover with four 3/4" Tek Screws (44); **start all four Tek Screws before tightening them. Be careful not to overtighten the Tek Screws.**

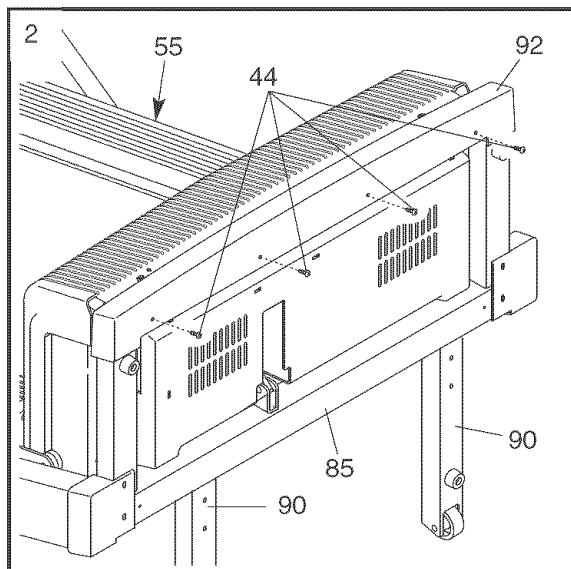

3. Attach the Base Extensions (90) with four Extension Screws (87); **start all four Extension Screws before tightening them.**

Attach the two Thin Base Pads (83) to the base of the Uprights (85) in the locations shown with two 1" Tek Screws (82).

Note: Replacement Base Pads may be included. Use the Base Pads to replace any that becomes worn.

With the help of a second person, carefully tip the Uprights (85) back to the vertical position.

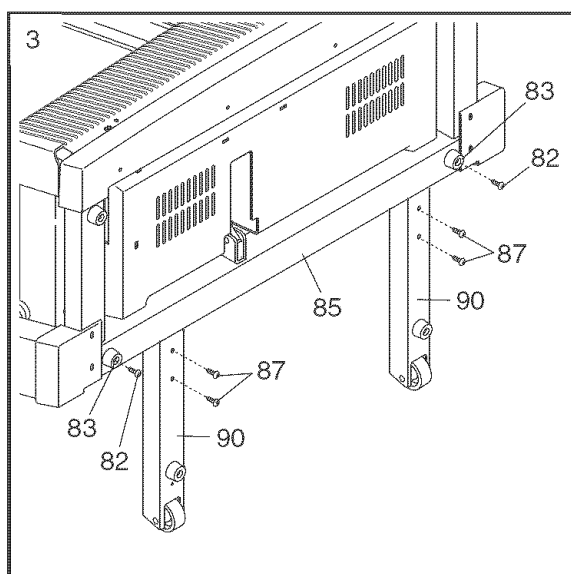

4. With the help of a second person, raise the Frame (55) to the vertical position.

While the other person holds the Frame (55), press the smaller end of the Shock (86) onto the bracket on the base of the Uprights (85). **Make sure to orient the Shock as shown.** Press the other end of the Shock onto the bracket on the Frame. Note: It may be necessary to tip the Frame forward or back to attach the Shock. **Do not tip the Frame forward past the vertical position.**

Carefully lower the Frame (55) to the floor.

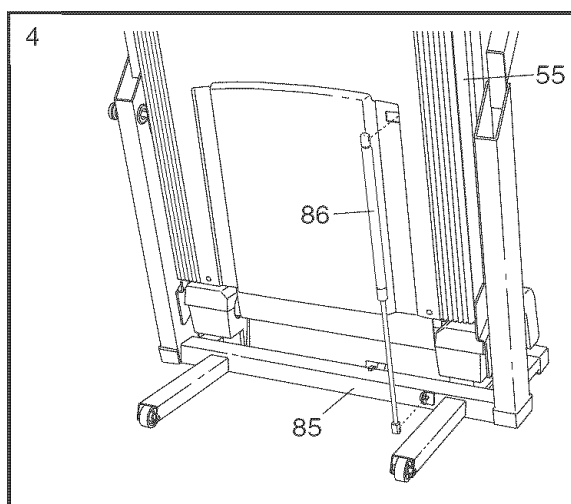

- Cut the tie securing the Pulse Wire (74) to the right Upright (85). Hold the Pulse Bar Assembly (69) near the crossbar on the Uprights. Connect the Pulse Wire to the wire in the Pulse Bar Assembly. **The connectors should slide together easily and snap into place. If they do not, turn one connector and try again.** Insert the wires into the crossbar.

**Open parts bag B.** Attach the Pulse Bar Assembly (69) to the crossbar on the Uprights (85) with four Pulse Bar Bolts (127) and Star Washers (67). Start all four Pulse Bar Bolts before tightening them. **Make sure that no wires are pinched.**

**If you have purchased an optional chest pulse sensor, follow step 6 to install the receiver included with the chest pulse sensor. If you have not, go to step 7.**

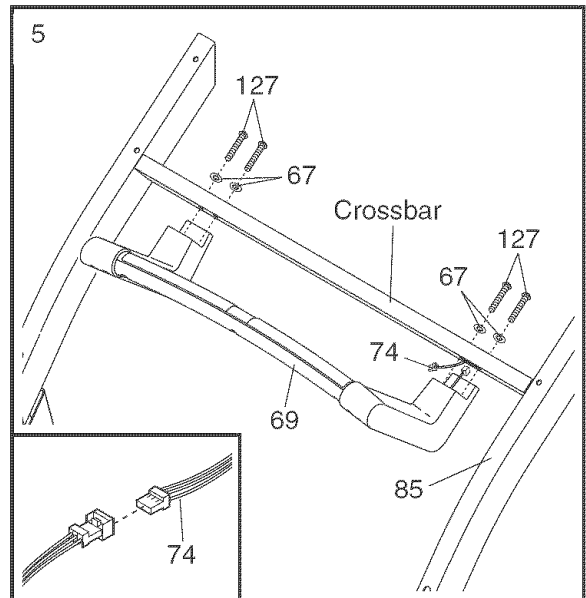

- Place the console assembly face-down. **Be careful not to scratch the face of the console.** Remove the indicated 3/4" Screw (7) and the Access Door (95) from the left side of the Console Back (96).

Connect the wire on the receiver (A) to the indicated wire extending from the Console Back (96). **Hold the receiver so the small cylinder is oriented as shown and is facing the Console Back.** Attach the receiver to the plastic posts on the Access Door (95) with the two included small screws.

**Make sure that no wires are pinched.** Reattach the Access Door (95) with the 3/4" Screw (7). Discard the other wires included with the receiver.

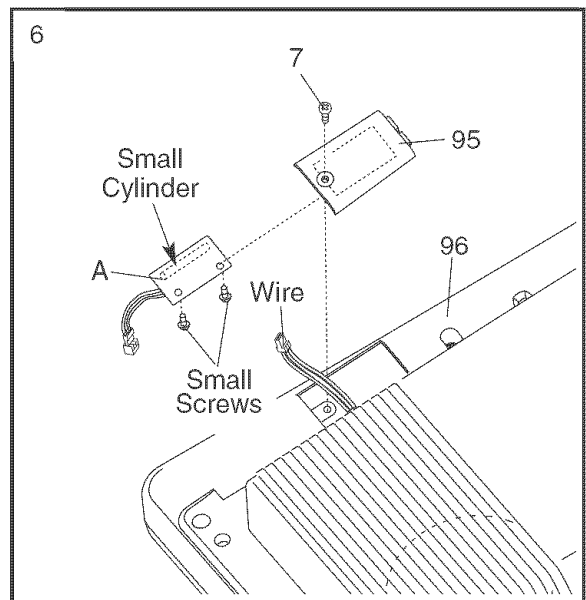

- Cut the tie securing the wires to the right Upright (85). Have a second person hold the console assembly near the Uprights. Connect the Upright Wire Harness (73) and the Pulse Wire (74) to the wires extending from the console assembly. **The connectors should slide together easily and snap into place. If they do not, turn one connector and try again.** Insert the connectors into the console assembly. If necessary, remove the right accessory tray (not shown) from the console assembly.

Connect the Upright Ground Wire (113) to the ground wire extending from the console assembly. Make sure that the wires are fully inserted into each other. Insert the ground wires into the console assembly. Reinsert the right accessory tray (not shown) into the console assembly if necessary.

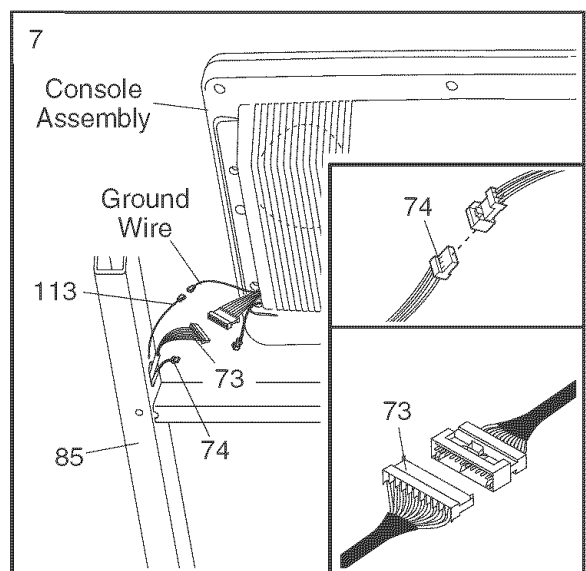



- Set the console assembly on the Uprights (85). **Make sure that no wires are pinched.** Finger tighten a Console Bolt (72) with a Star Washer (67) into the lower hole in each Upright (only one side is shown).

Next, **finger tighten** a Short Console Bolt (112) with a Star Washer (67) into the upper hole in each Upright (85) (only one side is shown). **Be careful not to drop the Short Console Bolts into the Uprights.** Firmly tighten the two Console Bolts (72) and the two Short Console Bolts.

Insert an Upright Endcap (71) into the top of each Upright (85) (only one side is shown). Note: Insert the end of the Upright Endcap indicated by the arrow first; use a rubber mallet if necessary.

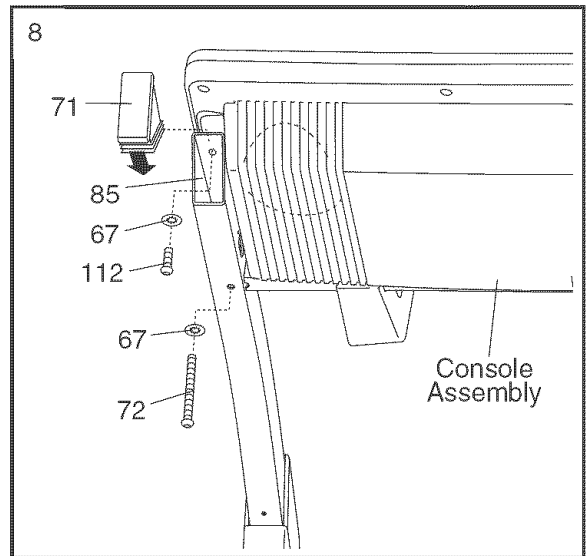

- Slide the two Upright Covers (75) onto the ends of the Handrails (68, 70). Align the holes in the lower ends of the Handrails with the holes in the Uprights (85). Do not drop the Handrails into the Uprights. **Do not cut the indicated tie.**

Loosely thread four Handrail Bolts (66) with four Star Washers (67) into the Handrails (68, 70) and the Uprights (85). **Firmly tighten the four Handrail Bolts.**

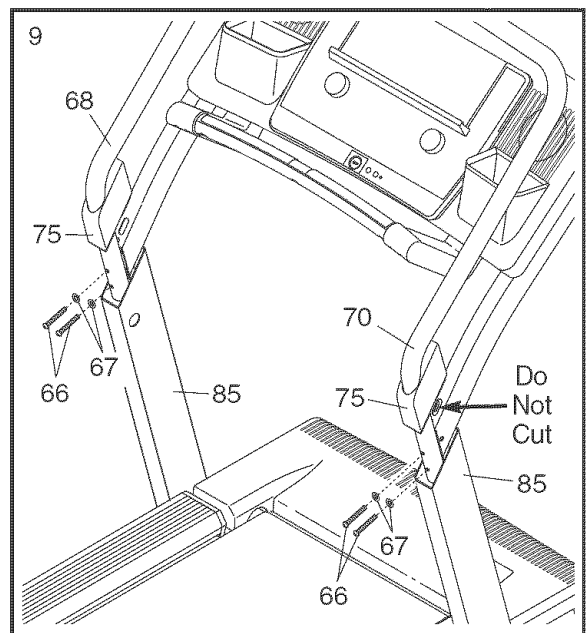

- Press the right Upright Cover (75) onto the right Upright (85). Attach the Upright Cover with a 3/4" Screw (7).

Repeat this step on the other side (not shown).

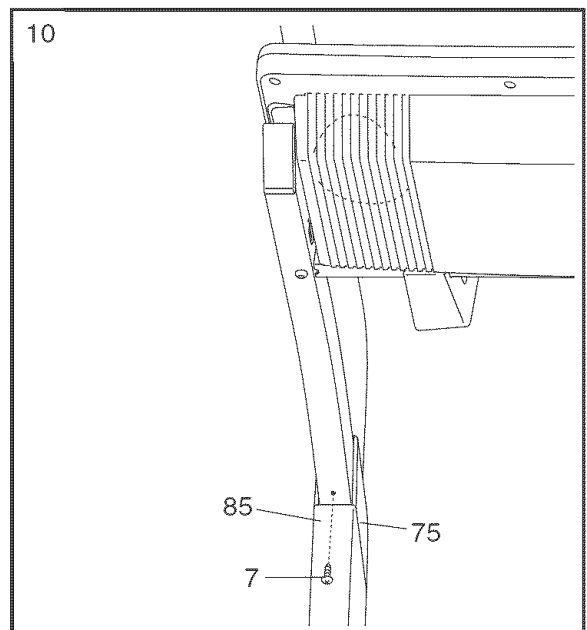

11. Remove the knob from the pin. Make sure that the collar and the spring are on the pin.

Press the Latch Insert (77) into the left Upright (85) as shown. Use a rubber mallet if necessary. Insert the pin through the Latch Insert. Tighten the knob back onto the pin.

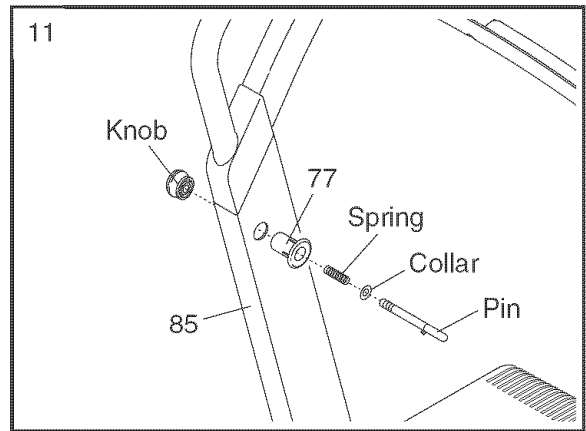

12. **Make sure that all parts are properly tightened before you use the treadmill.** Keep the included allen wrench in a secure place. The allen wrench is used to adjust the walking belt (see page 31). **To protect the floor or carpet from damage, place a mat under the treadmill.**

---

If you purchase the optional chest pulse sensor (see page 27) after the treadmill is assembled, follow the steps below to install the receiver included with the chest pulse sensor.

1. **Make sure that the power cord is unplugged.** Follow assemble steps 8 to 10 in reverse order (begin with step 10).
2. Lift the left side of the console assembly. **Be careful not to pull any wires.** Remove the indicated 3/4" Screw (7) and the Access Door (95) from the left side of the Console Back (96).
3. Connect the wire on the receiver (A) to the indicated wire extending from the Console Back (96). **Hold the receiver so the small cylinder is oriented as shown and is facing the Console Back.** Attach the receiver to the plastic posts on the Access Door (95) with the two included small screws.
4. **Make sure that no wires are pinched.** Reattach the Access Door (95) with the 3/4" Screw (7). Discard the other wires included with the receiver.
5. Repeat assembly steps 8 to 10.

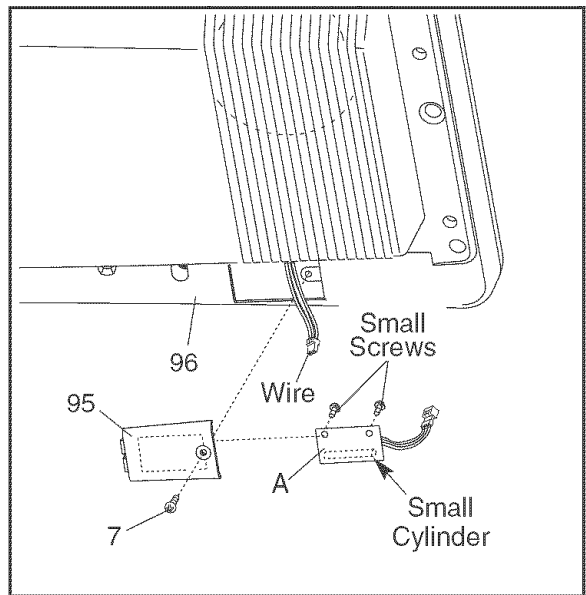

# OPERATION AND ADJUSTMENT

## THE PRE-LUBRICATED WALKING BELT

Your treadmill features a walking belt coated with high-performance lubricant. **IMPORTANT:** Never apply silicone spray or other substances to the walking belt or the walking platform. Such substances will deteriorate the walking belt and cause excessive wear.

## HOW TO PLUG IN THE POWER CORD

**⚠ DANGER:** Improper connection of the equipment-grounding conductor can result in an increased risk of electric shock. Check with a qualified electrician or serviceman if you are in doubt as to whether the product is properly grounded. Do not modify the plug provided with the product—if it will not fit the outlet, have a proper outlet installed by a qualified electrician.

Your treadmill, like any other type of sophisticated electronic equipment, can be seriously damaged by sudden voltage changes in your home's power. Voltage surges, spikes, and noise interference can result from weather conditions or from other appliances being turned on or off. **To decrease the possibility of your treadmill being damaged, always use a surge suppressor with your treadmill (see drawing 1 at the right).** To purchase a surge suppressor, see your local NordicTrack dealer or call 1-888-825-2588 and order part number 146148.

Use only a single-outlet surge suppressor that is UL 1449 listed as a transient voltage surge suppressor (TVSS). The surge suppressor must have a UL suppressed voltage rating of 400 volts or less and a minimum surge dissipation of 450 joules. The surge suppressor must be electrically rated for 120 volts AC and 15 amps. There must be a monitoring light on the surge suppressor to indicate whether it is functioning properly. Failure to use a properly functioning surge suppressor could result in damage to the control system of the treadmill. If the control system is damaged, the walking belt may change speed, accelerate, or stop unexpectedly, which may result in a fall and serious injury.

**This product must be grounded.** If it should malfunction or break down, grounding provides a path of least resistance for electric current to reduce the risk of electric shock. This product is equipped with a cord having

an equipment-grounding conductor and a grounding plug. **Plug the power cord into a surge suppressor, and plug the surge suppressor into an appropriate outlet that is properly installed and grounded in accordance with all local codes and ordinances. Important: The treadmill is not compatible with GFCI-equipped outlets.**

This product is for use on a nominal 120-volt circuit, and has a grounding plug that looks like the plug illustrated in drawing 1 below. A temporary adapter that looks like the adapter illustrated in drawing 2 may be used to connect the surge suppressor to a 2-pole receptacle as shown in drawing 2 if a properly grounded outlet is not available.

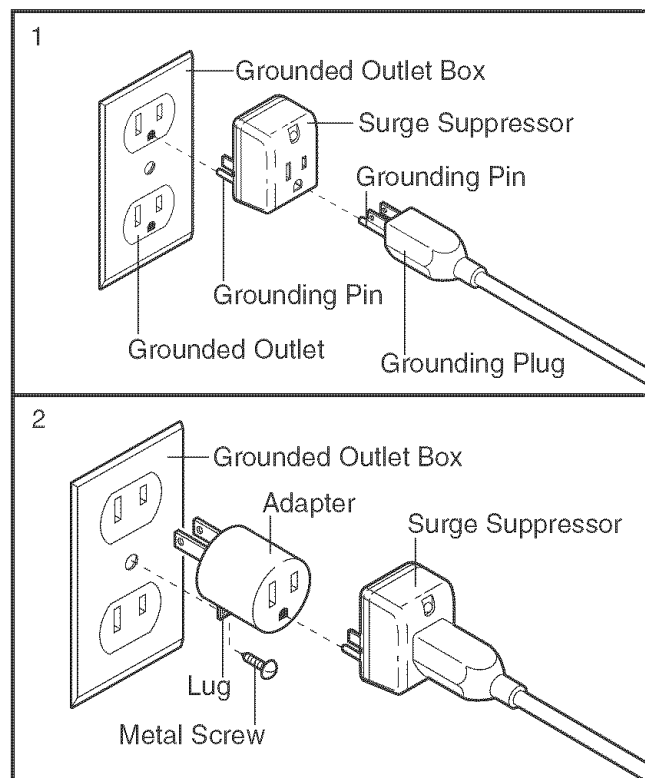

The temporary adapter should be used only until a properly grounded outlet (drawing 1) can be installed by a qualified electrician.

The green-colored rigid ear, lug, or the like extending from the adapter must be connected to a permanent ground such as a properly grounded outlet box cover. Whenever the adapter is used it must be held in place by a metal screw. **Some 2-pole receptacle outlet box covers are not grounded. Contact a qualified electrician to determine if the outlet box cover is grounded before using an adapter.**

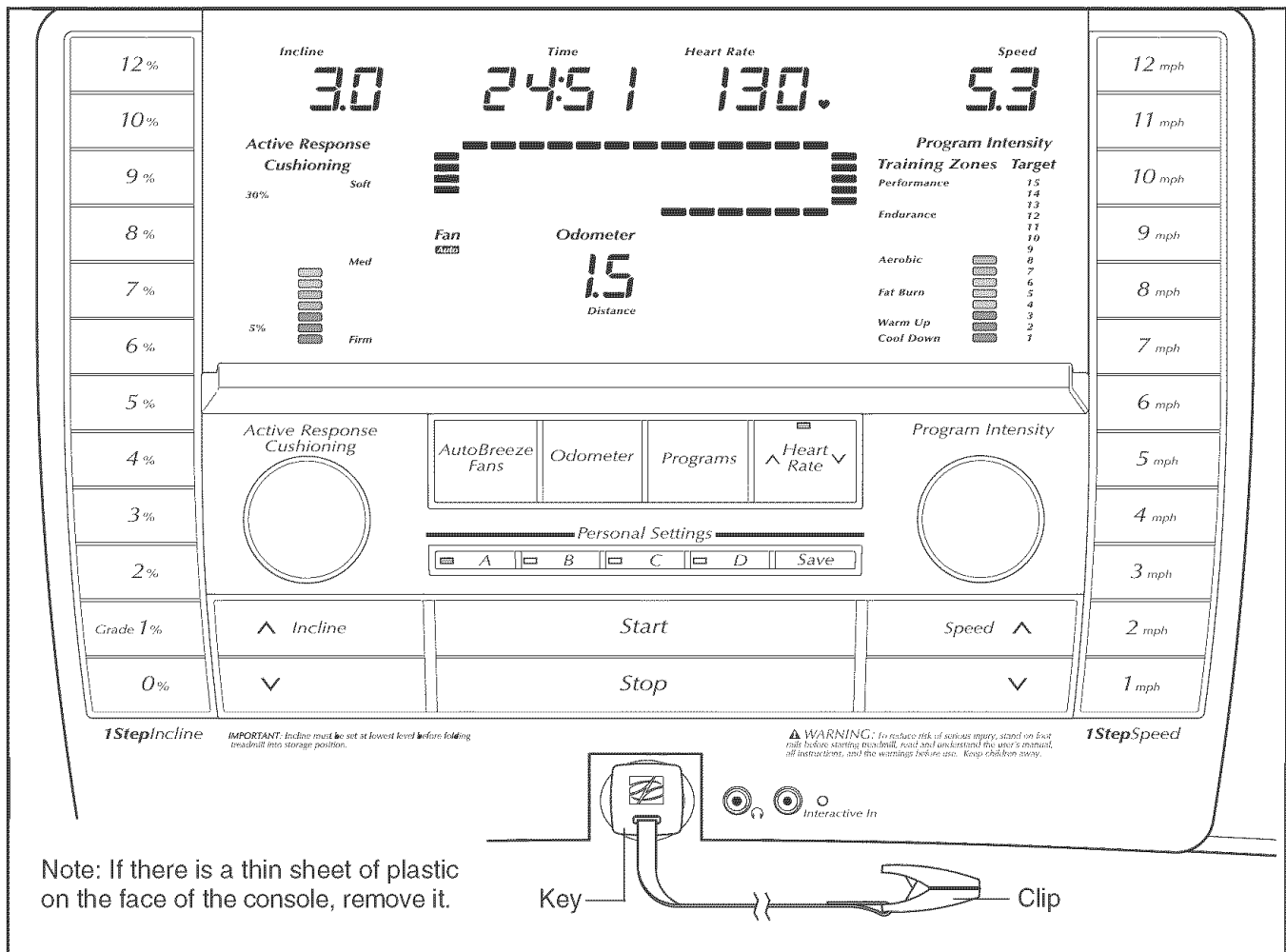

Note: If there is a thin sheet of plastic on the face of the console, remove it.

## FEATURES OF THE CONSOLE

The treadmill console offers an impressive array of features designed to make your workouts more effective and enjoyable. When the manual mode of the console is selected, the speed and incline of the treadmill can be changed with the touch of a button. As you exercise, the console will display continuous exercise feedback. You can even measure your heart rate using the built-in handgrip pulse sensor or the optional chest pulse sensor (see page 27).

In addition, the console features ten preset programs that automatically control the speed and incline of the treadmill as they guide you through effective workouts. You can even create your own custom workout programs and save them in memory for future use. The console also offers four heart rate programs that control the speed and incline of the treadmill to keep your heart rate near a target heart rate during your workouts. Note: You must wear the optional chest pulse sensor to use the heart rate programs.

The console also features iFIT.com interactive technology. Having iFIT.com technology is like having a per-

sonal trainer in your home. Using a stereo audio cable, you can connect the treadmill to your portable stereo, home stereo, computer, or VCR and play special iFIT.com MP3, CD, and video programs (iFIT.com MP3 programs, CDs, and videocassettes are available separately). iFIT.com programs automatically control the speed and incline of the treadmill as a personal trainer guides you through every step of your workout; high-energy music provides added motivation. **To purchase and download iFIT.com MP3 programs, go to [www.iFIT.com](http://www.iFIT.com). To purchase iFIT.com CDs or videocassettes, call toll-free 1-888-825-2588.**

With the treadmill connected to your computer, you can also go to [www.iFIT.com](http://www.iFIT.com) and access iFIT.com programs directly from our Web site. **See [www.iFIT.com](http://www.iFIT.com) for more information.**

**To use the manual mode of the console**, follow the steps beginning on page 13. **To use a preset program**, see page 16. **To create and use a custom program**, see pages 18 and 19. **To use a heart rate program**, see page 20. **To use an iFIT.com MP3, CD, or video program**, see page 24. **To use an iFIT.com program directly from our Web site**, see page 26.

## HOW TO TURN ON THE POWER

**1** Plug in the power cord (see page 11).

**2** Locate the reset/off circuit breaker near the power cord. Make sure that the circuit breaker is in the reset position.

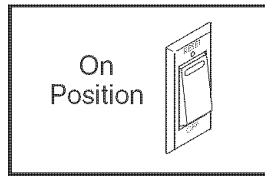

**3** Stand on the foot rails of the treadmill. Find the clip attached to the key (see the drawing on page 12) and attach the clip securely to the waistband of your clothes. Next, insert the key into the console. After a moment, the display will light. Note: When the power is turned on, the program that was selected the last time the Save button was pressed will automatically be reselected. If the Save button has not yet been pressed, the manual mode will be selected.

**Test the clip by carefully taking a few steps backward until the key is pulled from the console. If the key is not pulled from the console, adjust the position of the clip as needed.**

## HOW TO USE THE MANUAL MODE

**1** Insert the key into the console.

See HOW TO TURN ON THE POWER above.

**2** Designate yourself as user A, B, C, or D.

The console can save program settings for up to four different users. To designate yourself as user A, B, C, or D, press one of the Personal Setting buttons labeled A, B, C, and D.

**3** Select the manual mode.

To select the manual mode, press the Programs button repeatedly until a track appears in the center of the display. Make sure that the word "Programs" does not appear below the track.

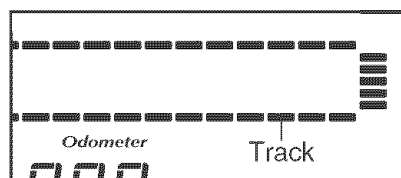

**4** Start the walking belt.

To start the walking belt, press the Start button, the Speed increase button, or one of the twelve 1-Step Speed buttons.

If the Start button or the Speed increase button is pressed, the walking belt will begin to move at 1 mph. As you exercise, change the speed of the walking belt as desired by pressing the Speed increase and decrease buttons. Each time a button is pressed, the speed setting will change in increments of 0.1 mph; if a button is held down, the speed setting will change in increments of 0.5 mph. Note: After the buttons are pressed, it may take a moment for the walking belt to reach the selected speed setting.



If one of the 1-Step Speed buttons is pressed, the walking belt will gradually increase in speed until it reaches the selected speed setting.

To stop the walking belt, press the Stop button. The time will begin to flash in the display. To restart the walking belt, press the Start button, the Speed increase button, or one of the 1-Step Speed buttons.

**5** Change the incline of the treadmill as desired.

To change the incline of the treadmill, press the Incline increase and decrease buttons or one of the twelve 1-Step Incline buttons.

Each time the Incline increase or decrease button is pressed, the incline will change by 0.5%. Note: After the buttons are pressed, it may take a moment for the treadmill to reach the selected incline setting.



If one of the 1-Step Incline buttons is pressed, the incline will gradually increase until it reaches the selected incline setting.

## 6 Adjust the cushioning system as desired.

The treadmill features a cushioning system that reduces the impact as you walk or run on the treadmill. There are fifteen firmness levels. To increase the firmness of the walking platform, turn the Active Response Cushioning knob counterclockwise. To decrease the firmness, turn the knob clockwise. The display will show the selected firmness level. If you wish to save the selected firmness level, press the Save button. Note: A clicking sound may be heard when the cushioning system is being adjusted.

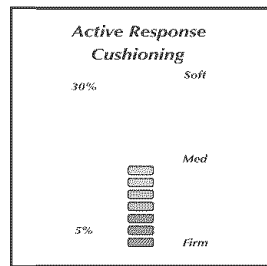

## 7 Follow your progress with the display.

When the manual mode or the iFIT.com mode is selected, the center of the display will show a 1/4-mile track. As you walk or run, the indicators around the track will light in succession until the entire track is lit. The track will then darken and the indicators will again begin to light in succession.

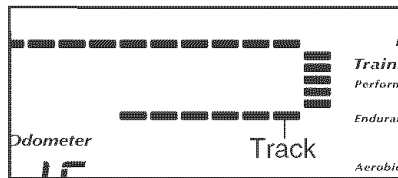

The lower right zone of the display will show a training zone bar that indicates the approximate intensity level of your exercise. If eight indicators in the bar are lit, for example, the bar shows that your pace is ideal for aerobic exercise.

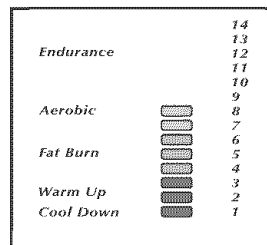

The Incline/Carbs zone of the display will show the incline level of the treadmill and the approximate number of grams of carbs you have burned.



Note: Each time the incline changes, the display will show the incline setting for a few seconds.

The Time zone of the display will show the elapsed time. Note: When a program is selected, the display will show the time remaining in the program instead of the elapsed time.

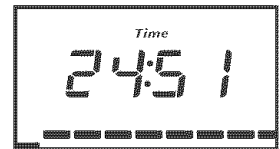

The Heart Rate/Calories zone of the display will show the approximate number of calories you have burned. The display will also show your heart rate when you use the handgrip pulse sensor or the optional chest pulse sensor.



The Pace/Speed zone of the display will show the speed of the walking belt and your pace (pace is measured in minutes per mile).



Note: The console can display speed and distance in either miles or kilometers. To find which unit of measurement is selected, hold down the Stop button while inserting the key into the console. An "E" for English miles or an "M" for metric kilometers will appear in the Pace/Speed zone of the display. Press the Speed increase button to change the unit of measurement. When the desired unit of measurement is selected, remove the key and then reinsert it. **Note: For simplicity, all instructions in this section refer to miles.**

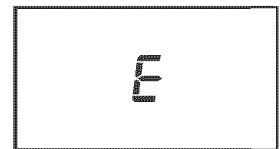

The Odometer zone of the display will show the distance that you have walked or run during your workout.

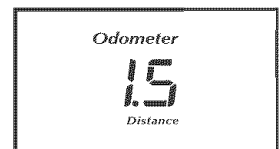

To see the total number of miles that the walking belt has moved since the treadmill was purchased, press the Odometer button; the words "Total Miles" and the total number of miles will appear in the display.

To see the total number of miles that the walking belt has moved during a recent period of time, such as the most recent month, press the Odometer button again; the words "My Miles" and the total number of miles will appear in the display. To reset this number, hold down the Odometer button for a few seconds.

To again see the distance that you have walked or run during your workout, press the Odometer button again.

To reset the display, press the Stop button, remove the key, and then reinsert the key.

### 8 Measure your heart rate if desired.

Note: If you use the handgrip pulse sensor and the optional chest pulse sensor at the same time, the console will

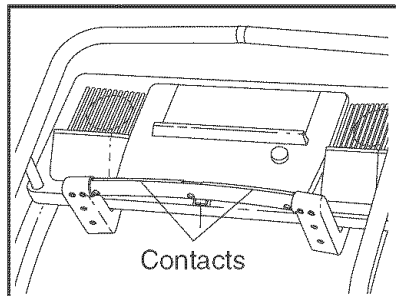

not display your heart rate accurately. Before using the handgrip pulse sensor, remove the clear plastic film from the metal contacts. In addition, make sure that your hands are clean.

To measure your heart rate, **stand on the foot rails** and hold the metal contacts—**avoid moving your hands**. When your pulse is detected, the heart symbol in the Heart Rate/Calories zone of the display will appear, one or two dashes will appear, and then your heart rate will be shown. **For the most accurate heart rate reading, continue to hold the contacts for about 15 seconds.**

### 9 Turn on the fans if desired.

To turn on the fans at low speed, press the AutoBreeze Fans button; the number 1 will appear below the word “Fan” in



the display. To turn on the fans at medium speed, press the button a second time; the number 2 will appear. To turn on the fans at high speed, press the button a third time; the number 3 will appear. To select the Auto mode, press the button again; the word “Auto” will appear. When the auto mode is selected, the speed of the fans will automatically increase and decrease as the speed of the walking belt increases and decreases.

To turn off the fans, press the AutoBreeze Fans button again. Note: A few minutes after the walking belt is stopped, the fans will automatically turn off.

### 10 When you are finished exercising, remove the key.

Step onto the foot rails, press the Stop button, and **adjust the incline of the treadmill to the lowest setting. The incline must be at the lowest setting when the treadmill is folded to the storage position or the treadmill will be damaged.** Next, remove the key from the console and put it in a secure place. **Note: If the display remains lit after the key is removed, the console is in the “demo” mode. See page 27 and turn off the demo mode.**

**When you are finished using the treadmill, switch the reset/off circuit breaker to the off position and unplug the power cord.**

Note: The first time the treadmill is used, observe the alignment of the walking belt, and align the walking belt if necessary (see page 31).

## HOW TO USE A PRESET PROGRAM

### 1 Insert the key into the console.

See HOW TO TURN ON THE POWER on page 13.

### 2 Identify yourself as user A, B, C, or D.

See step 2 on page 13.

### 3 Select one of the preset programs.

To select one of the ten preset programs, press the Programs button repeatedly until the words "Weight Loss," "Aerobic," or "Performance" and the number 1, 2, 3, or 4 appear in the lower center of the display.

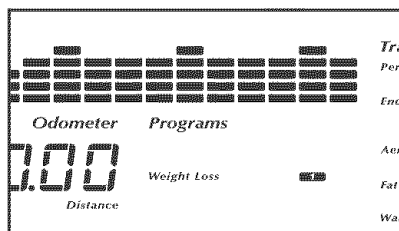

As each preset program is selected, the maximum speed setting of the program and the maximum incline setting of the program will flash in the display for a few seconds. The Time zone of the display will show how long the program will last. A profile of the speed settings of the program will scroll across the matrix in the center of the display.

### 4 Adjust the intensity level of the program if desired.

The lower right zone of the display will show the intensity level of the selected program; there are fifteen intensity levels. If desired, turn the Program Intensity dial to increase or decrease the intensity level of the program. If you change the intensity level, the new maximum speed setting of the program and the new maximum incline setting of the program will flash in the display for a few seconds. In addition, the profile in the matrix will change to show the

Program Intensity	
Training Zones	Target
Performance	15
	14
	13
Endurance	12
	11
	10
Aerobic	9
	8
	7
Fat Burn	6
	5
	4
Warm Up	3
	2
Cool Down	1

new speed settings of the program. If you wish to save the new intensity level of the program for future workouts, press the Save button.

### 5 Press the Start button or the Speed increase button to start the program.

A moment after the button is pressed, the treadmill will automatically adjust to the first speed and incline settings for the program. Hold the handrails and begin walking.

Each program is divided into several one-minute segments. One speed setting and one incline setting are programmed for each segment. Note: The same speed setting and/or incline setting may be programmed for two or more consecutive segments.

The speed setting for the first segment will be shown in the flashing Current Segment

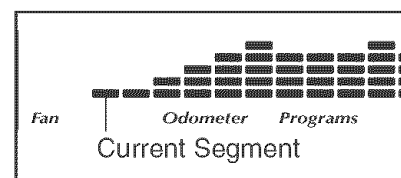

Segment column of the matrix. (The incline settings are not shown in the matrix.) The speed settings for the next twelve segments will be shown in the twelve columns to the right.

When only three seconds remain in the first segment of the program, both the Current Segment column and the column to the right will flash and a series of tones will sound. If the speed and/or incline of the treadmill is about to change, the speed setting and/or incline setting will flash in the display to alert you.

When the first segment is completed, *all speed settings will move one column to the left.* The speed setting for the second segment will then be shown in the flashing Current Segment column and the treadmill will automatically adjust to the speed and incline settings for the second segment. Note: If all seven of the indicators in the Current Segment column are lit, *the speed settings may also move downward* so that only the highest indicators appear in the matrix.

The program will continue in this way until the speed setting for the last segment is shown in the Current Segment column and the last segment ends. The walking belt will then slow to a stop.



If the speed and/or incline settings of the program are too high or too low, you can change the intensity level of the program at any time by turning the Program Intensity dial. If you wish to save the new intensity level of the program for future workouts, press the Save button.

To stop the program at any time, press the Stop button. The time will begin to flash in the display. To restart the program, press the Start button or the Speed increase button. The walking belt will begin to move at 1 mph. When the next segment of the program begins, the treadmill will automatically adjust to the speed and incline settings for the next segment.

**6** Adjust the cushioning system as desired.

See step 6 on page 14.

**7** Follow your progress with the display.

See step 7 on page 14.

**8** Measure your heart rate if desired.

See step 8 on page 15.

**9** Turn on the fans if desired.

See step 9 on page 15.

**10** When you are finished exercising, remove the key from the console.

When the program ends, **make sure that the incline of the treadmill is at the lowest setting.** Next, remove the key from the console and put it in a safe place. **Note: If the display remains lit after the key is removed, the console is in the “demo” mode. See page 27 and turn off the demo mode.**

When you are finished using the treadmill, switch the reset/off circuit breaker to the off position and unplug the power cord.

## HOW TO CREATE A CUSTOM PROGRAM

### 1 Insert the key into the console.

See HOW TO TURN ON THE POWER on page 13.

### 2 Identify yourself as user A, B, C, or D.

See step 2 on page 13.

### 3 Select one of the custom programs.

To select a custom program, press the Programs button repeatedly until the words "My Design" and the number "1" or "2" appear in the display.

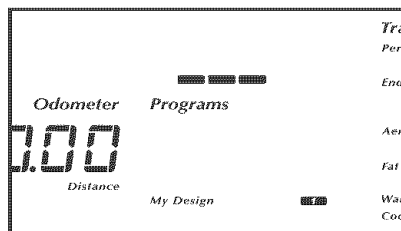

**Note:** If the custom program has not yet been defined, only three columns of indicators will scroll across the matrix in the center of the display. If more than three columns of indicators appear, see HOW TO USE A CUSTOM PROGRAM on page 19.

### 4 Press the Start button or the Speed increase button and program the desired speed and incline settings.

A moment after the button is pressed, the walking belt will begin to move. Hold the handrails and begin walking.

Refer to the matrix. Each custom program is divided into one-minute segments.

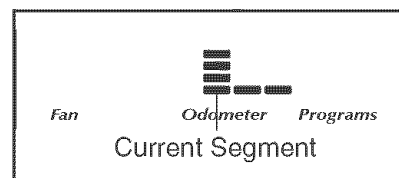

One speed setting and one incline setting can be programmed for each segment. The speed setting for the first segment will be shown in the flashing Current Segment column of the matrix. (The incline settings are not shown in the matrix.) To program a speed setting and an incline setting for the first segment, simply adjust the speed and incline of the treadmill as desired by pressing the Speed and Incline buttons. Every few times a Speed button is pressed, an additional indicator will appear or disappear in the Current Segment column.

When the first segment of the program ends, a series of tones will sound and the current speed setting and the current incline setting will be saved in memory. *The three columns of indicators will then move one column to the left*, and the speed setting for the second segment will be shown in the flashing Current Segment column. Program a speed setting and an incline setting for the second segment as described above.

Continue programming speed and incline settings for as many segments as desired; custom programs can have up to forty segments. When you are finished with your workout, press the Stop button twice. The speed and incline settings that you have programmed and the number of segments that you have programmed will then be saved in memory.

### 5 When you are finished exercising, remove the key from the console.

See step 10 on page 17.

## HOW TO USE A CUSTOM PROGRAM

### 1 Insert the key into the console.

See HOW TO TURN ON THE POWER on page 13.

### 2 Identify yourself as user A, B, C, or D.

See step 2 on page 13.

### 3 Select one of the custom programs.

To select a custom program, press the Programs button repeatedly until the words "My Design" and the number "1" or "2" will appear in the display.

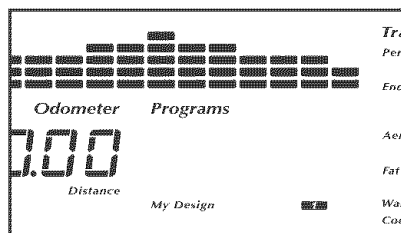

As each custom program is selected, the maximum speed setting of the program and the maximum incline setting of the program will flash in the display for a few seconds. The Time zone of the display will show how long the program will last. A profile of the speed settings of the program will scroll across the matrix in the center of the display. **Note: If only three columns of indicators scroll across the matrix, see HOW TO CREATE A CUSTOM PROGRAM on page 18.**

### 4 Press the Start button or the Speed increase button to start the program.

A moment after the button is pressed, the treadmill will automatically adjust to the first speed and incline settings that you programmed previously. Hold the handrails and begin walking.

Each custom program is divided into several one-minute segments. One speed setting and one incline setting are programmed for each segment. Note: The same speed setting and/or incline setting may be programmed for two or more consecutive segments.

The speed setting for the first segment will be shown in the flashing Current Segment

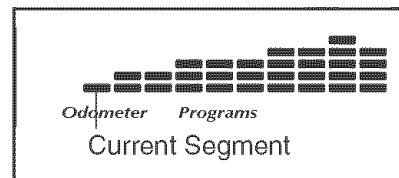

Segment column of the matrix. (The incline settings are not shown in the matrix.) The speed settings for the next nine segments will be shown in the columns to the right.

When only three seconds remain in the first segment of the program, both the Current Segment column and the column to the right will flash and a series of tones will sound. If the speed and/or incline of the treadmill is about to change, the speed setting and/or incline setting will flash in the display to alert you.

When the first segment is completed, *all speed settings will move one column to the left.* The speed setting for the second segment will then be shown in the flashing Current Segment column and the treadmill will automatically adjust to the speed and incline settings for the second segment.

The program will continue in this way until the speed setting for the last segment is shown in the Current Segment column and the last segment ends. The walking belt will then slow to a stop.

If desired, you can redefine the program while using it. **To change the speed or incline setting for the current segment,** simply press the Speed or Incline buttons. When the current segment ends, the new setting will be saved in memory. **To increase the length of the program,** first wait until the program is completed. Then, press the Start button and program speed and incline settings for as many additional segments as desired. When you have added as many segments as desired, press the Stop button twice. **To decrease the length of the program,** press the Stop button twice at any time before the program is completed.

To stop the program at any time, press the Stop button. The time will begin to flash in the display. To restart the program, press the Start button or the Speed increase button. The walking belt will begin to move at 1 mph. When the next segment of the program begins, the treadmill will automatically adjust to the speed and incline settings for the next segment.

**5** Adjust the cushioning system as desired.

See step 6 on page 14.

**6** Follow your progress with the display.

See step 7 on page 14.

**7** Measure your heart rate if desired.

See step 8 on page 15.

**8** Turn on the fans if desired.

See step 9 on page 15.

**9** When you are finished exercising, remove the key from the console.

See step 10 on page 17.

**HOW TO USE A HEART RATE PROGRAM**

**CAUTION:** If you have heart problems, or if you are over 60 years of age and have been inactive, do not use the heart rate programs. If you are taking medication regularly, consult your physician to find whether the medication will affect your exercise heart rate.

Follow the steps below to use a heart rate program.

**1** Put on the optional chest pulse sensor.

You must wear the optional chest pulse sensor (see page 27) to use a heart rate program.

**2** Insert the key into the console.

See HOW TO TURN ON THE POWER on page 13.

**3** Identify yourself as user A, B, C, or D.

See step 2 on page 13.

**4** Select a heart rate program.

To select a heart rate program, press the Programs button repeatedly until the words "Heart Rate" and the number 1, 2, 3, or 4 appear in the lower center of the display.

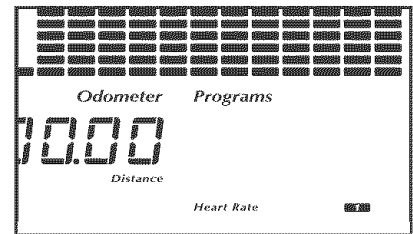

As each heart rate program is selected, a profile of the target heart rate settings of the selected program will scroll across the matrix in the center of the display. Note: If heart rate program 4 is selected, a heart beat symbol instead of a profile will scroll across the matrix.

**5** Enter a maximum target heart rate setting.

When a heart rate program is selected, the words "Heart Rate" will appear in the Heart Rate/Calories zone of the display and the maximum target heart rate setting of the program will flash. If desired, press the Heart Rate increase and decrease buttons to change the maximum target heart rate setting. To save the new maximum target heart rate setting for future workouts, press the Save button. Note: See the heart rate chart on page 32 for heart rate guidelines.

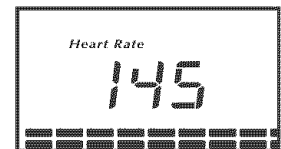

**6** Press the Start button or the Speed increase button to start the program.

A moment after the button is pressed, the treadmill will automatically adjust to the first speed and incline settings of the program. Hold the handrails and begin walking.

Each heart rate program is divided into 20 one-minute segments. One target heart rate setting is programmed for each segment. Note: The same target heart rate setting may be programmed for two or more consecutive segments. If heart rate program 4 is selected, the maximum target heart rate setting is programmed for all segments.

The target heart rate setting for the first segment will be shown in the flashing

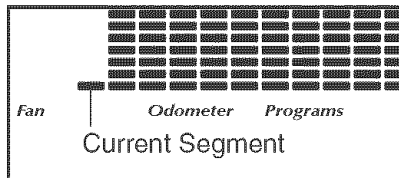

Current Segment column of the matrix. The target heart rate settings for the next twelve segments will be shown in the columns to the right.

If heart rate program 4 is selected, the target heart rate setting will not be shown in the matrix. Instead, a heart beat symbol will scroll across the matrix.

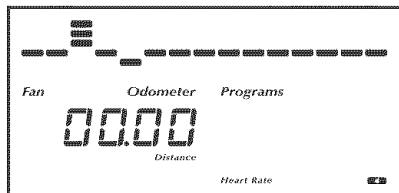

When only three seconds remain in the first segment of the program, both the Current Segment column and the column to the right will flash and a series of tones will sound. In addition, the speed setting and/or incline setting will flash in the display. When the first segment ends, *all target heart rate settings will move one column to the left.* The target heart rate setting for the second segment will then be shown in the flashing Current Segment column.

During each segment, the console will compare your heart rate to the target heart rate setting. If your heart rate is too far below or above the target heart rate setting, the speed of the walking belt will automatically increase or decrease to bring your heart rate closer to the target heart rate setting. If the speed reaches the maximum speed setting of the program (7.5 mph) and your heart rate is still too far below the target heart rate setting, the incline of the treadmill will also increase to bring your heart rate closer to the target heart rate setting.

The program will continue in this way until the target heart rate setting for the last segment is

shown in the Current Segment column and the last segment ends. The walking belt will then slow to a stop.

If the speed and/or incline settings of the program are too high or too low, you can change the intensity level of the program at any time by pressing the Heart Rate increase and decrease buttons to change the maximum target heart rate setting. If you wish to save the new maximum target heart rate setting for future workouts, press the Save button.

If your pulse is not detected during the program, the letters "PLS" will flash in the Heart Rate/Calories zone of the display and the speed and incline of the treadmill may automatically decrease until your pulse is detected. If this occurs, see the instructions included with the optional chest pulse sensor.

To stop the program at any time, press the Stop button. The time will begin to flash in the display. To restart the program, press the Start button or the Speed increase button. The walking belt will begin to move at 1 mph. When the console compares your heart rate to the target heart rate, the speed and/or incline of the treadmill will automatically change to bring your heart rate closer to the target heart rate.

## **7** Adjust the cushioning system as desired.

See step 6 on page 14.

## **8** Follow your progress with the displays.

See step 7 on page 14.

## **9** Turn on the fans if desired.

See step 9 on page 15.

## **10** When you are finished exercising, remove the key.

See step 10 on page 17.

## HOW TO CONNECT THE TREADMILL TO USE IFIT.COM PROGRAMS

To use iFIT.com MP3 or CD programs, the treadmill must be connected to your MP3 player, CD player, portable stereo, home stereo, or computer. See pages 22 and 23 for connecting instructions. To use iFIT.com programs directly from our Web site, the treadmill must be connected to your computer. See page 23 for connecting instructions. To use iFIT.com video programs, the treadmill must be connected to your VCR. See page 24 for connecting instructions.

## HOW TO CONNECT YOUR MP3 PLAYER OR CD PLAYER

- A. Plug one end of the included 1/8" to 1/8" stereo audio cable into the input jack on the console. Plug the other end of the cable into a jack on your MP3 player or CD player. Plug your headphones into the headphone jack on the console.

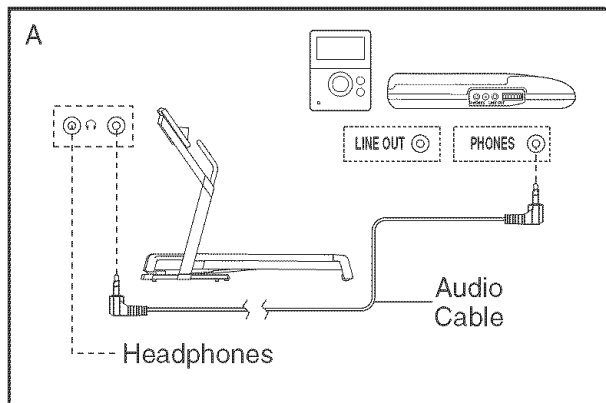

## HOW TO CONNECT YOUR PORTABLE STEREO

Note: If your stereo has an RCA-type AUDIO OUT jack, see instruction A below. If your stereo has a 1/8" LINE OUT jack, see instruction B. If your stereo has only a PHONES jack, see instruction C.

- A. Plug one end of a long 1/8" to RCA stereo audio cable (available at electronics stores) into the input jack on the console. Plug the other end of the cable into the AUDIO OUT jack on your stereo.

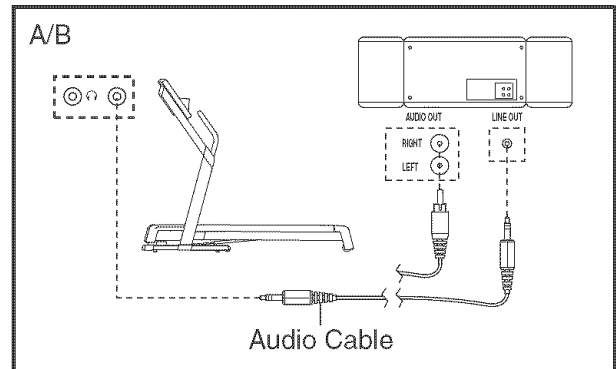

- B. See the drawing above. Plug one end of a long 1/8" to 1/8" stereo audio cable (available at electronics stores) into the input jack on the console. Plug the other end of the cable into the LINE OUT jack on your stereo. Note: While the cable is plugged into the LINE OUT jack, do not plug your headphones into the headphone jack on the console.

- C. Plug one end of a long 1/8" to 1/8" stereo audio cable (available at electronics stores) into the input jack on the console. Plug the other end of the cable into the PHONES jack on your stereo. Plug your headphones into the headphone jack on the console.

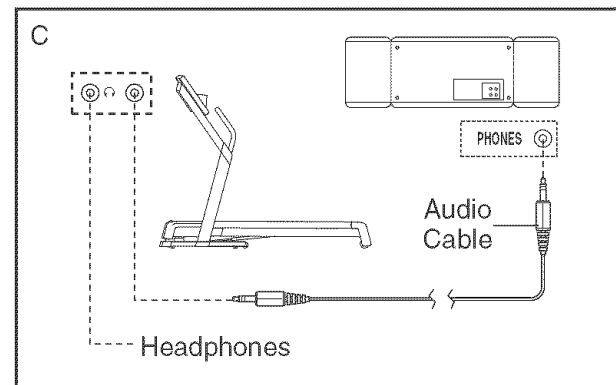

## HOW TO CONNECT YOUR HOME STEREO

**Note:** If your stereo has an unused **LINE OUT** jack, see instruction **A** below. If the **LINE OUT** jack is being used, see instruction **B**.

- A. Plug one end of a long 1/8" to RCA stereo audio cable (available at electronics stores) into the input jack on the console. Plug the other end of the cable into the **LINE OUT** jack on your stereo. Note: While the cable is plugged into the **LINE OUT** jack, do not plug your headphones into the headphone jack on the console.

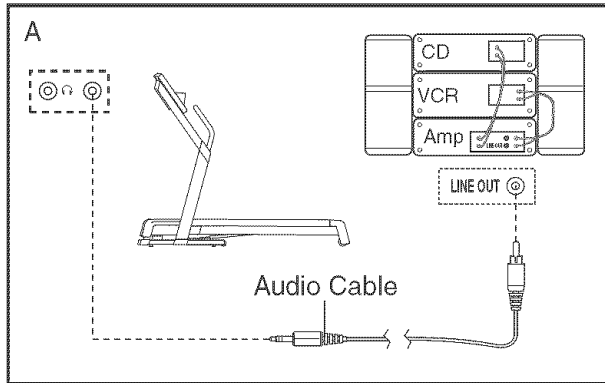

- B. Plug one end of a long 1/8" to RCA stereo audio cable (available at electronics stores) into the input jack on the console. Plug the other end of the cable into an RCA Y-adapter (available at electronics stores). Next, remove the wire that is currently plugged into the **LINE OUT** jack on your stereo and plug the wire into the unused side of the Y-adapter. Plug the Y-adapter into the **LINE OUT** jack on your stereo. Note: While the Y-adapter is plugged into the **LINE OUT** jack, do not plug your headphones into the headphone jack on the console.

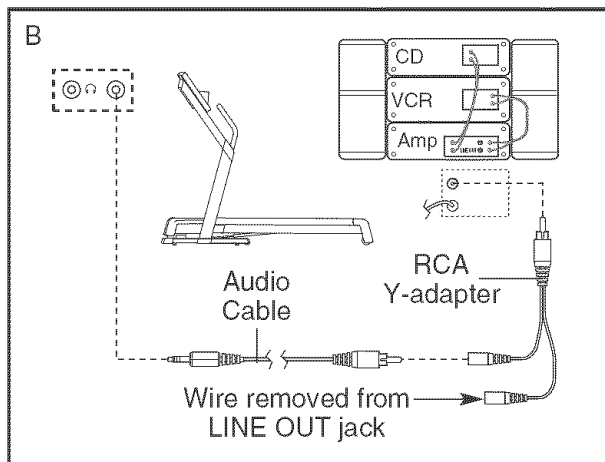

## HOW TO CONNECT YOUR COMPUTER

- A. Plug one end of a long 1/8" to 1/8" stereo audio cable (available at electronics stores) into the input jack on the console. Plug the other end of the cable into the **LINE OUT** jack on your computer. Note: While the cable is plugged into the **LINE OUT** jack, do not plug your headphones into the headphone jack on the console.

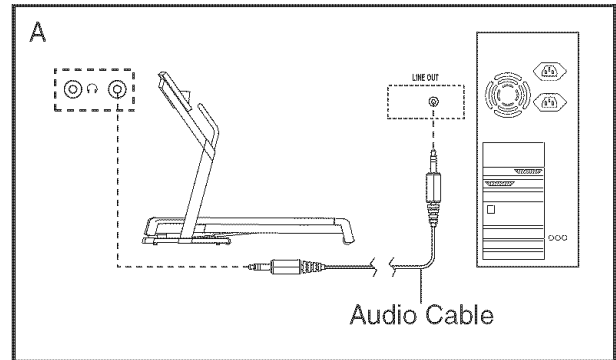

## HOW TO CONNECT YOUR VCR

**Note:** If your VCR has an unused AUDIO OUT jack, see instruction A below. If the AUDIO OUT jack is being used, see instruction B. If you have a TV with a built-in VCR, see instruction B. If your VCR is connected to your home stereo, see **HOW TO CONNECT YOUR HOME STEREO** on page 23.

- A. Plug one end of a long 1/8" to RCA stereo audio cable (available at electronics stores) into the input jack on the console. Plug the other end of the cable into the AUDIO OUT jack on your VCR.

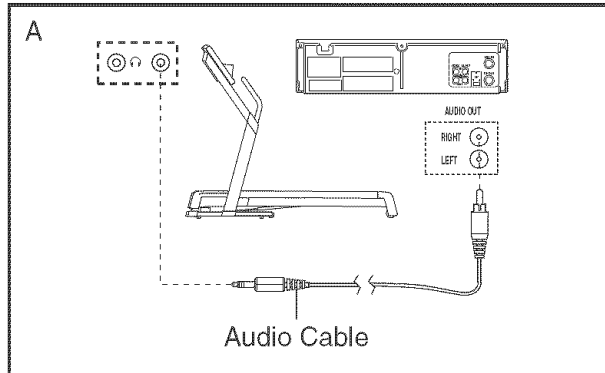

- B. Plug one end of a long 1/8" to RCA stereo audio cable (available at electronics stores) into the input jack on the console. Plug the other end of the cable into an RCA Y-adapter (available at electronics stores). Next, remove the wire that is currently plugged into the AUDIO OUT jack on your VCR and plug the wire into the unused side of the Y-adapter. Plug the Y-adapter into the AUDIO OUT jack on your VCR.

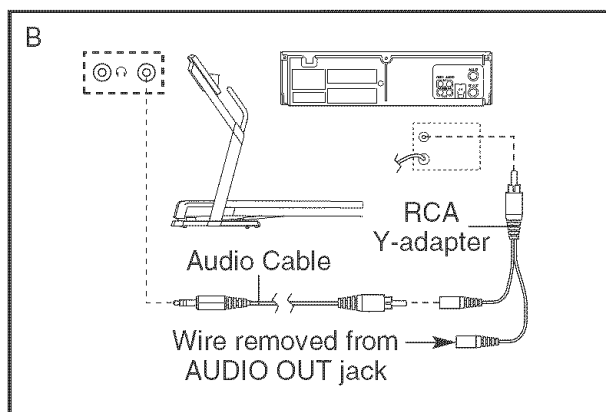

## HOW TO USE AN iFIT.COM MP3, CD, OR VIDEO PROGRAM

To use an iFIT.com MP3, CD, or video program, the treadmill must be connected to your MP3 player, CD player, or VCR. See **HOW TO CONNECT THE TREADMILL TO USE iFIT.COM PROGRAMS** on pages 22 to 24. **To purchase and download iFIT.com MP3 programs, go to [www.iFIT.com](http://www.iFIT.com). To purchase iFIT.com CDs or videocassettes, call toll-free 1-888-825-2588.**

Follow the steps below to use an iFIT.com MP3, CD, or video program.

### 1 Insert the key into the console.

See **HOW TO TURN ON THE POWER** on page 13.

### 2 Identify yourself as user A, B, C, or D.

See step 2 on page 13.

### 3 Select the iFIT.com mode.

To select the iFIT.com mode, press the Programs button until the letters "iFIT" appear in the display.

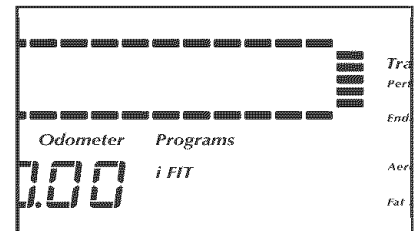

### 4 Press the Play button on your MP3 player, CD player, or VCR.

**Note:** If you are using an iFIT.com CD, insert the CD into your CD player; if you are using an iFIT.com videocassette, insert the videocassette into your VCR.

A moment after the Play button is pressed, your personal trainer will begin guiding you through your workout. Simply follow your personal trainer's instructions. **Note:** If the time is flashing in the display, press the Start button or the Speed increase button on the console. The treadmill will not respond to an MP3, CD, or video program while the time is flashing in the display.



During the program, an electronic “chirping” sound will alert you when the speed and/or incline of the treadmill is about to change. **CAUTION: Always listen for the “chirp” and be prepared for speed and/or incline changes. In some instances, the speed and/or incline may change before your personal trainer describes the change.**

If the speed or incline settings are too high or too low, you can manually override the settings at any time by pressing the Speed or Incline buttons on the console. However, **when the next “chirp” is heard, the speed and/or incline will change to the next settings of the program.**

To stop the walking belt at any time, press the Stop button on the console. The time will begin to flash in the display. To restart the program, press the Start button or the Speed increase button. After a moment, the walking belt will begin to move at 1 mph. **When the next “chirp” is heard, the speed and/or incline will change to the next settings of the program.**

When the program is completed, the walking belt will stop. Note: To use another MP3, CD, or video program, press the Stop button or remove the key and go to step 1 on page 24.

**Note: If the speed and/or incline of the treadmill does not change when a “chirp” is heard:**

- **Make sure that the letters “iFIT” appear in the display and that the time is not flashing in the display. If the time is flashing, press the Start button or the Speed increase button on the console.**

- **Adjust the volume of your MP3 player, CD player, or VCR. If the volume is too high or too low, the console may not detect the program signals.**
- **Make sure that the audio cable is properly connected.**
- **If you are using a portable CD player and the CD skips, set the CD player on the floor or another flat surface instead of on the console.**

**5 Adjust the cushioning system as desired.**

See step 6 on page 14.

**6 Follow your progress with the display.**

See step 7 on page 14.

**7 Measure your heart rate if desired.**

See step 8 on page 15.

**8 Turn on the fans if desired.**

See step 9 on page 15.

**9 When you are finished exercising, remove the key from the console.**

See step 10 on page 17.

**CAUTION: Always remove iFIT.com CDs and videocassettes from your CD player and VCR and disconnect your MP3 player when you are not using them.**

## HOW TO USE AN iFIT.COM PROGRAM DIRECTLY FROM OUR WEB SITE

Our Web site at [www.iFIT.com](http://www.iFIT.com) allows you to access programs directly from the internet. Additional options are soon to be available. See [www.iFIT.com](http://www.iFIT.com) for details.

To use programs from our Web site, the treadmill must be connected to your home computer. See HOW TO CONNECT YOUR COMPUTER on page 23. In addition, you must have an internet connection and an internet service provider. A list of specific system requirements is found on our Web site.

Follow the steps below to use a program from our Web site.

### **1** Insert the key into the console.

See HOW TO TURN ON THE POWER on page 13.

### **2** Identify yourself as user A, B, C, or D.

See step 2 on page 13.

### **3** Select the iFIT.com mode.

See step 3 on page 24.

### **4** Go to your computer and start an internet connection.

### **5** Start your web browser, if necessary, and go to our Web site at [www.iFIT.com](http://www.iFIT.com).

### **6** Follow the desired links on our Web site to select a program.

Read and follow the on-line instructions for using a program.

### **7** Follow the on-line instructions to start the program.

When you start the program, an on-screen countdown will begin.

### **8** Return to the treadmill and stand on the foot rails. Find the clip attached to the key and slide the clip onto the waistband of your clothes.

When the on-screen countdown ends, the program will begin and the walking belt will begin to move.

Hold the handrails, step onto the walking belt, and begin walking. During the program, an electronic “chirping” sound will alert you when the speed and/or incline of the treadmill is about to change.

**CAUTION: Always listen for the “chirp” and be prepared for speed and/or incline changes.**

If the speed or incline settings are too high or too low, you can manually override the settings at any time by pressing the Speed or Incline buttons on the console. **However, when the next “chirp” is heard, the speed and/or incline will change to the next settings for the program.**

To stop the walking belt at any time, press the Stop button on the console. The time will begin to flash in the display. To restart the program, press the Start button or the Speed increase button. After a moment, the walking belt will begin to move at 1.0 mph. **When the next “chirp” is heard, the speed and incline will change to the next settings of the program.**

When the program is completed, the walking belt will stop. Note: To use another program, press the Stop button and go to step 5.

**Note: If the speed and/or incline of the treadmill does not change when a “chirp” is heard, make sure that the letters “iFIT” appear in the display and that the time is not flashing in the display. In addition, make sure that the audio cable is properly connected.**

### **9** Adjust the cushioning system as desired.

See step 6 on page 14.

### **10** Follow your progress with the display.

See step 7 on page 14.

### **11** Measure your heart rate if desired.

See step 8 on page 15.

### **12** Turn on the fans if desired.

See step 9 on page 15.

### **13** When you are finished exercising, remove the key from the console.

See step 10 on page 17.

## THE INFORMATION MODE/DEMO MODE

The console features an information mode that keeps track of the total number of hours that the treadmill has been used and the total number of miles that the walking belt has moved. The information mode also allows you to select miles or kilometers as the unit of measurement for the console, to turn on and turn off the demo mode, and to reset all programs to the original settings.

To select the information mode, hold down the Stop button while inserting the key into the console. When the information mode is selected, the following information will be shown in the display:

The Time zone of the display will show the total number of hours that the treadmill has been used. The Odometer zone will show the total number of miles (or kilometers) that the walking belt has moved. An "E" for English miles or an "M" for metric kilometers will appear in the Pace/Speed zone. Press the Speed increase button to change the unit of measurement if desired.

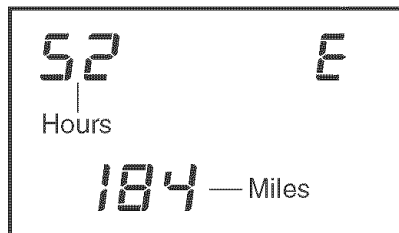

**IMPORTANT:** If a "d" appears in the Heart Rate/Calories zone of the display, the console is in the "demo" mode. This mode is intended to be used only when a treadmill is displayed in a store. When the console is in the demo mode, the power cord can be plugged in, the key can be removed from the console, and the indicators in the display will automatically light in a preset sequence, although the buttons on the console will not operate. **If a "d" appears when the information mode is selected, press the Speed decrease button so the "d" disappears.**

To reset all programs to the original settings, first press the Start button. The word "SAVE" will flash in the Pace/Speed zone of the display. To reset all programs, press the Save button. If you do not wish to reset all programs, press the Stop button.



To exit the information mode, remove the key from the console.

## THE OPTIONAL CHEST PULSE SENSOR

An optional chest pulse sensor offers hands-free operation and allows you to use the console's heart rate programs. **To purchase the optional chest pulse sensor, call toll-free 1-888-825-2588.**

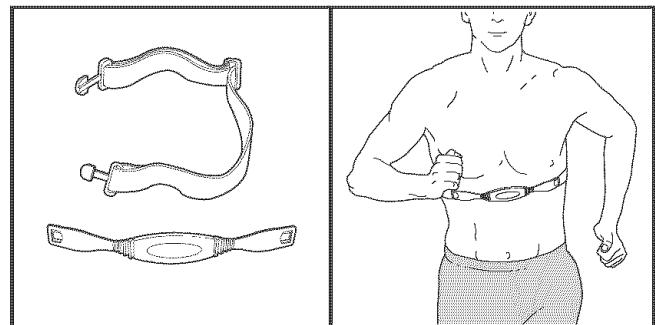

# HOW TO FOLD AND MOVE THE TREADMILL

## HOW TO FOLD THE TREADMILL FOR STORAGE

Before folding the treadmill, adjust the incline to the lowest position. If this is not done, the treadmill may be permanently damaged. Remove the key and unplug the power cord. **CAUTION: You must be able to safely lift 55 pounds (25 kg) to raise, lower, or move the treadmill.**

1. Hold the treadmill with your hands in the location shown by the arrow at the right. **CAUTION: To decrease the possibility of injury, bend your legs and keep your back straight. As you raise the treadmill, make sure to lift with your legs rather than your back.** Raise the treadmill about halfway to the vertical position.

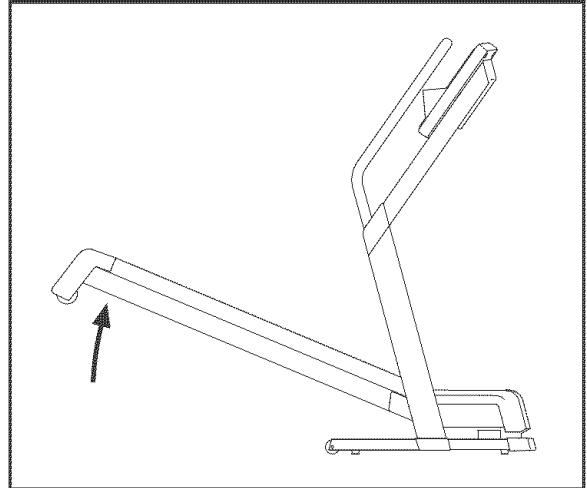

2. Move your right hand to the position shown and hold the treadmill firmly. Using your left hand, pull the latch knob to the left and hold it. Raise the treadmill until the latch pin is aligned with the indicated hole in the frame. Insert the latch pin into the hole. **Make sure that the latch pin is fully inserted into the hole.**

**To protect the floor or carpet from damage, place a mat under the treadmill. Keep the treadmill out of direct sunlight. Do not leave the treadmill in the storage position in temperatures above 85° Fahrenheit.**

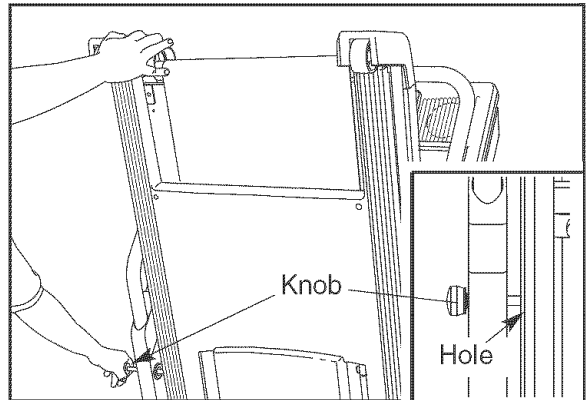

## HOW TO MOVE THE TREADMILL

Before moving the treadmill, convert the treadmill to the storage position as described above. **Make sure that the latch pin is fully inserted into the hole in the side of the treadmill.**

1. Hold the handrails as shown and place one foot against a wheel.
2. Tilt the treadmill back until it rolls freely on the wheels. Carefully move the treadmill to the desired location. **Never move the treadmill without tipping it back. To reduce the risk of injury, use extreme caution while moving the treadmill. Do not attempt to move the treadmill over an uneven surface.**
3. Place one foot on wheel, and carefully lower the treadmill until it is resting in the storage position.

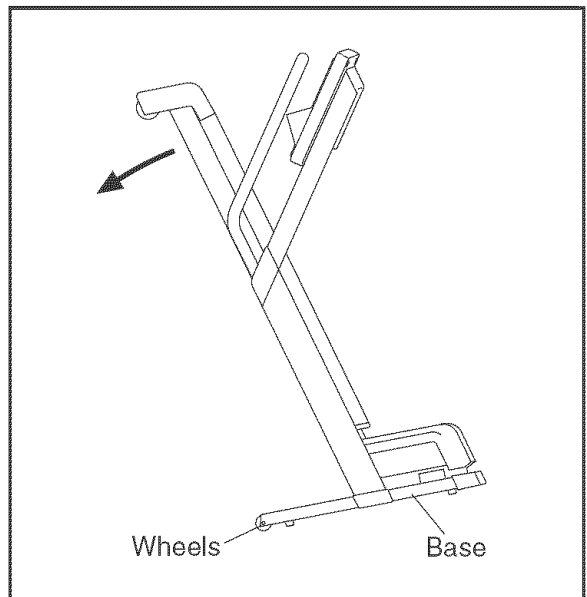

## HOW TO LOWER THE TREADMILL FOR USE

1. Hold the upper end of the treadmill with your right hand as shown. Using your left hand, pull the latch knob to the left and hold it. Pivot the treadmill down until the frame is past the pin on the latch knob.

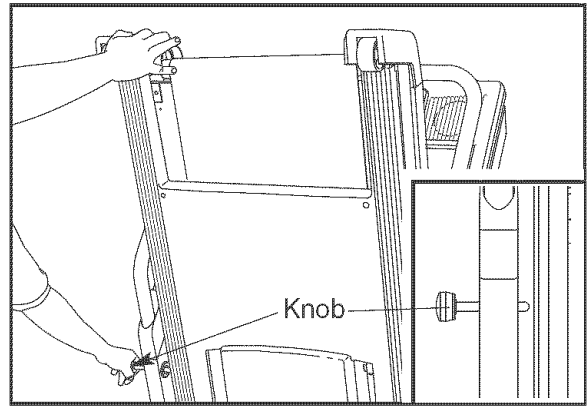

2. Hold the treadmill firmly with both hands, and lower the treadmill to the floor. **To decrease the possibility of injury, bend your legs and keep your back straight.**

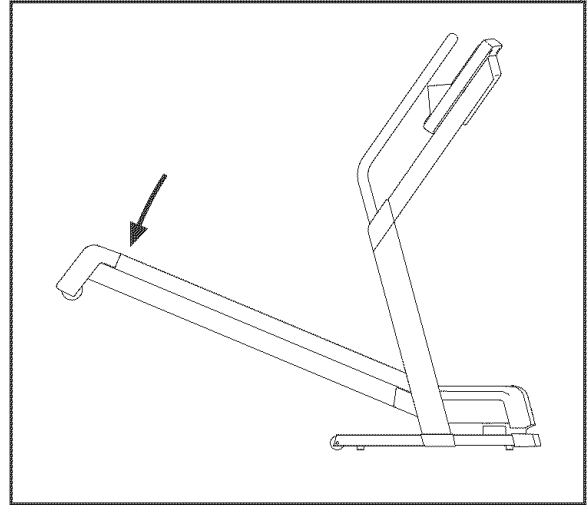

# TROUBLESHOOTING

Most treadmill problems can be solved by following the steps below. Find the symptom that applies, and follow the steps listed. If further assistance is needed, please call our Customer Service Department toll-free at 1-888-825-2588, Monday through Friday, 6 a.m. until 6 p.m. Mountain Time (excluding holidays).

**PROBLEM:** The power does not turn on

**SOLUTION:** a. Make sure that the power cord is plugged into a surge suppressor, and that the surge suppressor is plugged into a properly grounded outlet (see page 11). Use only a single-outlet surge suppressor that meets all of the specifications described on page 11. Important: The treadmill is not compatible with GFCI-equipped outlets.

b. After the power cord has been plugged in, make sure that the key is fully inserted into the console.

c. Check the reset/off circuit breaker located on the treadmill frame near the power cord. If the switch protrudes as shown, the circuit breaker has tripped. To reset the circuit breaker, wait for five minutes and then press the switch to the reset position.

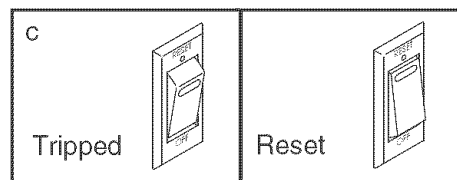

**PROBLEM:** The power turns off during use

**SOLUTION:** a. Check the reset/off circuit breaker (see the drawing above). If the circuit breaker has tripped, wait for five minutes and then press the switch to the reset position.

b. Make sure that the power cord is plugged in. If the power cord is plugged in, unplug it, wait for five minutes, and then plug it back in.

c. Remove the key from the console. Reinsert the key fully into the console.

d. If the treadmill still will not run, please call our Customer Service Department, toll-free.

**PROBLEM:** The displays of the console do not function properly

**SOLUTION:** a. Remove the key from the console and **UNPLUG THE POWER CORD**. Carefully lower the Uprights (85). Remove the two indicated Screws (7). A phillips screw driver with an 8" shaft is needed.

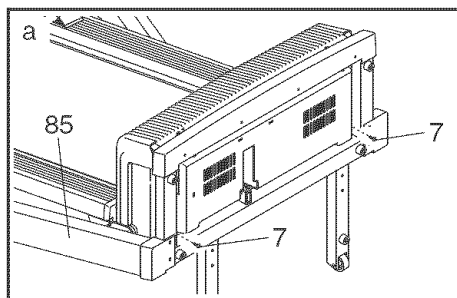

b. Raise the Uprights (85) to the vertical position. Remove the three Screws (7) from the Hood (33), and carefully pivot the Hood off.

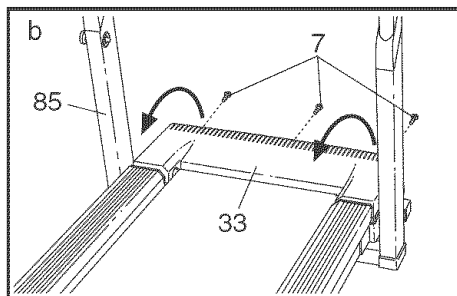

Locate the Reed Switch (22) and the Magnet (18) on the left side of the Pulley (17). Turn the Pulley until the Magnet is aligned with the Reed Switch. **Make sure that the gap between the Magnet and the Reed Switch is about 1/8".** If necessary, use a slotted screwdriver to move the Reed Switch slightly. Reattach the Hood (33), making sure that the Screws (7) are inserted into the same holes from which they were removed. Run the treadmill for a few minutes to check for a correct speed reading.

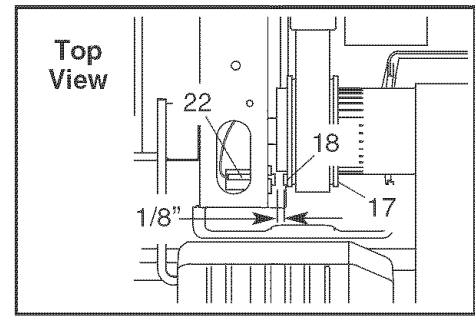

**PROBLEM: The walking belt slows when walked on**

**SOLUTION:** a. Use only a single-outlet surge suppressor that meets all of the specifications described on page 11.

b. If the walking belt is overtightened, treadmill performance may decrease and the walking belt may become damaged. Remove the key and **UNPLUG THE POWER CORD**. Using the allen wrench, turn both rear roller adjustment bolts counterclockwise, 1/4 of a turn. When the walking belt is properly tightened, you should be able to lift each side of the walking belt 3 to 4 inches off the walking platform. Be careful to keep the walking belt centered. Plug in the power cord, insert the key, and run the treadmill for a few minutes. Repeat until the walking belt is properly tightened.

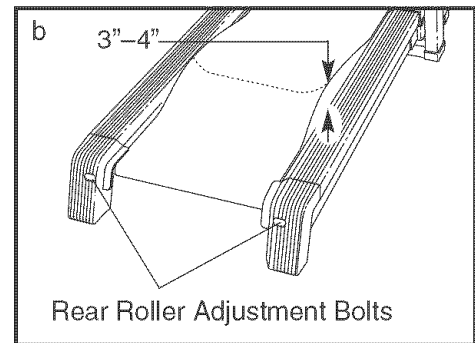

c. If the walking belt still slows when walked on, please call our Customer Service Department, toll-free.

**PROBLEM: The walking belt is off-center or slips when walked on**

**SOLUTION:** a. If the walking belt is off-center, remove the key and **UNPLUG THE POWER CORD**. **If the walking belt has shifted to the left**, use the allen wrench to turn the left rear roller bolt clockwise 1/2 of a turn; **if the walking belt has shifted to the right**, turn the left rear roller bolt counterclockwise 1/2 of a turn. Be careful not to overtighten the walking belt. Plug in the power cord, insert the key, and run the treadmill for a few minutes. Repeat until the walking belt is centered.

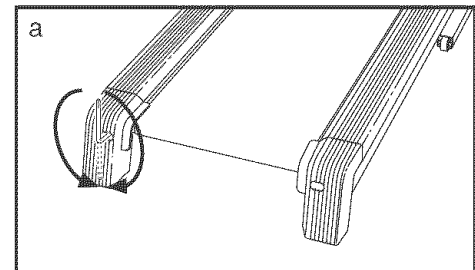

b. If the walking belt slips when walked on, first remove the key and **UNPLUG THE POWER CORD**. Using the allen wrench, turn both rear roller bolts clockwise, 1/4 of a turn. When the walking belt is correctly tightened, you should be able to lift each side of the walking belt 3 to 4 inches off the walking platform. Be careful to keep the walking belt centered. Plug in the power cord, insert the key, and carefully walk on the treadmill for a few minutes. Repeat until the walking belt is properly tightened.

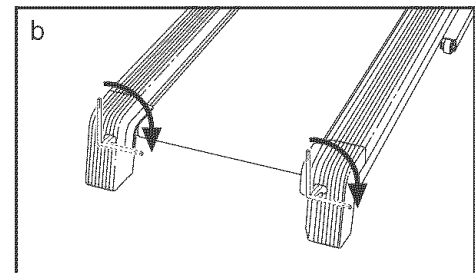

# CONDITIONING GUIDELINES

**⚠ WARNING:** Before beginning this or any exercise program, consult your physician. This is especially important for individuals over the age of 35 or individuals with pre-existing health problems.

The pulse sensor is not a medical device. Various factors, including your movement, may affect the accuracy of heart rate readings. The sensor is intended only as an exercise aid in determining heart rate trends in general.

The following guidelines will help you to plan your exercise program. For more detailed exercise information, obtain a reputable book or consult your physician.

## EXERCISE INTENSITY

Whether your goal is to burn fat or to strengthen your cardiovascular system, the key to achieving the desired results is to exercise with the proper intensity. The proper intensity level can be found by using your heart rate as a guide. The chart below shows recommended heart rates for fat burning and aerobic exercise.

HEART RATE TRAINING ZONES							
AEROBIC	165	155	145	140	130	125	115
MAX FAT BURN	145	138	130	125	118	110	103
FAT BURN	125	120	115	110	105	95	90
Age	20	30	40	50	60	70	80

To find the proper heart rate for you, first find your age near the bottom of the chart (ages are rounded off to the nearest ten years). Next, find the three numbers above your age. The three numbers define your “training zone.” The lower two numbers are recommended heart rates for fat burning; the higher number is the recommended heart rate for aerobic exercise.

To measure your heart rate during exercise, use the pulse sensor on the console.

### Fat Burning

To burn fat effectively, you must exercise at a relatively low intensity level for a sustained period of time. During the first few minutes of exercise, your body uses easily accessible *carbohydrate calories* for en-

ergy. Only after the first few minutes does your body begin to use stored *fat calories* for energy. If your goal is to burn fat, adjust the speed and incline of the treadmill until your heart rate is near the lowest number in your training zone.

For maximum fat burning, adjust the speed and incline of the treadmill until your heart rate is near the middle number in your training zone.

### Aerobic Exercise

If your goal is to strengthen your cardiovascular system, your exercise must be “aerobic.” Aerobic exercise is activity that requires large amounts of oxygen for prolonged periods of time. This increases the demand on the heart to pump blood to the muscles, and on the lungs to oxygenate the blood. For aerobic exercise, adjust the speed and incline of the treadmill until your heart rate is near the highest number in your training zone.

## WORKOUT GUIDELINES

Each workout should include the following three parts:

**A Warm-up**—Start each workout with 5 to 10 minutes of stretching and light exercise. A proper warm-up increases your body temperature, heart rate and circulation in preparation for exercise.

**Training Zone Exercise**—After warming up, increase the intensity of your exercise until your pulse is in your training zone for 20 to 60 minutes. (During the first few weeks of your exercise program, do not keep your pulse in your training zone for longer than 20 minutes.) Breathe regularly and deeply as you exercise—never hold your breath.

**A Cool-down**—Finish each workout with 5 to 10 minutes of stretching to cool down. This will increase the flexibility of your muscles and will help prevent post-exercise problems.

## EXERCISE FREQUENCY

To maintain or improve your condition, complete three workouts each week, with at least one day of rest between workouts. After a few months, you may complete up to five workouts each week if desired. The key to success is to make exercise a regular and enjoyable part of your everyday life.



## SUGGESTED STRETCHES

The correct form for several basic stretches is shown at the right. Move slowly as you stretch—never bounce.

### 1. Toe Touch Stretch

Stand with your knees bent slightly and slowly bend forward from your hips. Allow your back and shoulders to relax as you reach down toward your toes as far as possible. Hold for 15 counts, then relax. Repeat 3 times. Stretches: Hamstrings, back of knees and back.

### 2. Hamstring Stretch

Sit with one leg extended. Bring the sole of the opposite foot toward you and rest it against the inner thigh of your extended leg. Reach toward your toes as far as possible. Hold for 15 counts, then relax. Repeat 3 times for each leg. Stretches: Hamstrings, lower back and groin.

### 3. Calf/Achilles Stretch

With one leg in front of the other, reach forward and place your hands against a wall. Keep your back leg straight and your back foot flat on the floor. Bend your front leg, lean forward and move your hips toward the wall. Hold for 15 counts, then relax. Repeat 3 times for each leg. To cause further stretching of the achilles tendons, bend your back leg as well. Stretches: Calves, achilles tendons and ankles.

### 4. Quadriceps Stretch

With one hand against a wall for balance, reach back and grasp one foot with your other hand. Bring your heel as close to your buttocks as possible. Hold for 15 counts, then relax. Repeat 3 times for each leg. Stretches: Quadriceps and hip muscles.

### 5. Inner Thigh Stretch

Sit with the soles of your feet together and your knees outward. Pull your feet toward your groin area as far as possible. Hold for 15 counts, then relax. Repeat 3 times. Stretches: Quadriceps and hip muscles.

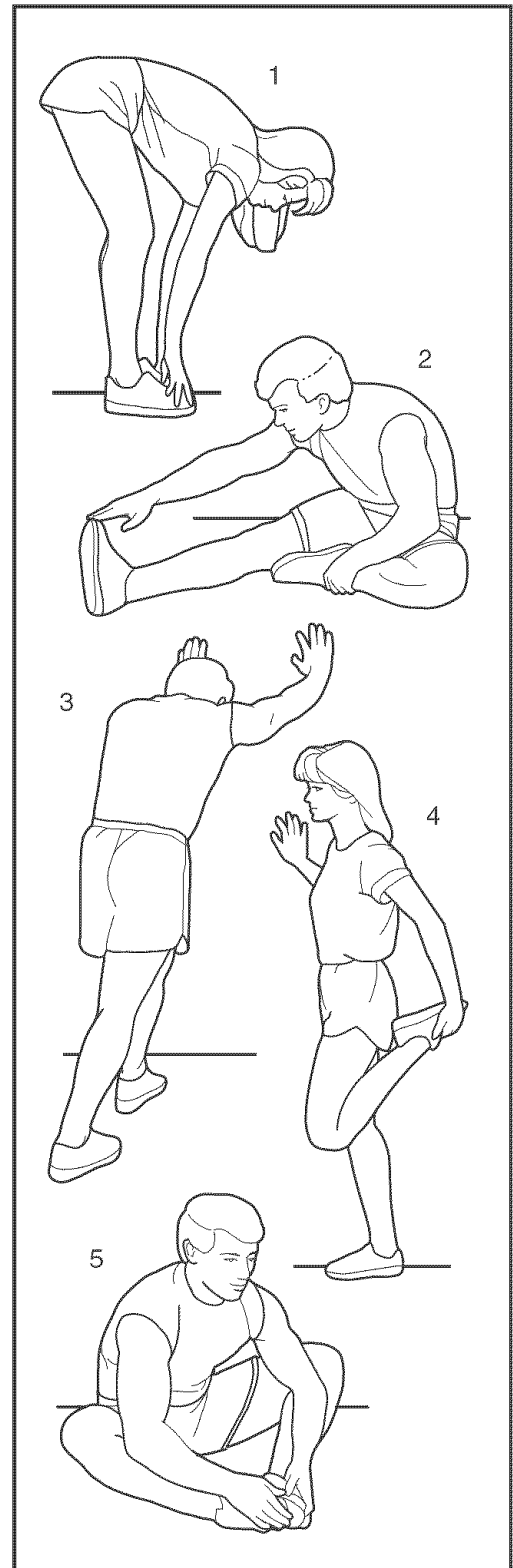

# PART LIST—Model No. NTL14950

R1204B

To locate the parts listed below, see the EXPLODED DRAWING attached in the center of this manual.

Key No.	Qty.	Description	Key No.	Qty.	Description
1	1	Left Foot Rail	52	1	Plastic Tie
2	20	Foot Rail Screw	53	1	Front Right Endcap
3	1	Front Left Endcap	54	1	Right Foot Rail
4	20	Screw	55	1	Frame
5	2	Platform Screw, Front	56	1	Ground Wire
6	1	Latch Warning Decal	57	2	Platform Nut
7	43	3/4" Screw	58	2	Wheel Bolt
8	2	Platform Screw, Rear	59	2	Rear Wheel
9	5	Spring Nut	60	2	Rear Roller Star Washer
10	4	Curved Washer	61	6	Rear Roller Washer/Spring Washer
11	2	Spring Plate	62	2	Rear Roller Bolt
12	2	Belt Guide	63	1	Right Rear Endcap
13	4	Belt Guide Screw	64	1	Rear Roller
14	2	Frame Pivot Bolt	65	1	Left Rear Endcap
15	1	Walking Platform	66	4	Handrail Bolt
16	1	Walking Belt	67	12	Star Washer
17	1	Front Roller	68	1	Left Handrail
18	1	Magnet	69	1	Pulse Bar Assembly
19	2	Frame Spacer	70	1	Right Handrail
20	8	Nut	71	2	Upright Endcap
21	1	Reed Switch Clip	72	2	Console Bolt
22	1	Reed Switch	73	1	Wire Harness
23	13	1/2" Screw	74	1	Pulse Wire
24	1	Cushion Housing, Left	75	2	Upright Cover
25	1	Drive Motor	76	1	Latch Assembly
26	1	Motor Belt	77	1	Latch Insert
27	2	Leaf Spring	78	1	Left Upright Cap
28	1	Controller Wire	79	1	Cushion Housing, Right
29	2	Spring Pad	80	2	Lift Frame Clevis Pin
30	2	Spring Spacer	81	4	Base Pad
31	2	Motor Bolt	82	6	1" Tek Screw
32	8	Platform Bracket	83	2	Thin Base Pad
33	1	Motor Hood	84	2	Caution Decal
34	3	Hood Clip	85	1	Uprights
35	1	Hood Foam, Left	86	1	Shock
36	1	Upper Clevis Pin	87	4	Extension Screw
37	4	Cotter Pin	88	2	Front Wheel Bolt
38	1	Front Roller Adjustment Bolt	89	2	Front Wheel
39*	1	Idler Arm Assembly	90	1	Base Extension
40	1	Incline Motor	91	1	Right Upright Cap
41	1	Lower Pin	92	1	Base Cover
42	1	Transformer	93	1	iFIT Cable
43	1	Controller	94	1	Lift Frame
44	14	3/4" Screw	95	1	Access Door
45	1	Belly Pan	96	1	Console Back
46	1	Power Cord Grommet	97	1	Right Accessory Tray
47	1	Power Cord	98	1	Console Front
48	1	Off/Reset Circuit Breaker	99	1	Left Accessory Tray
49	1	Outlet Bracket	100	2	Fan
50	2	Tie Holder	101	2	Endcap Screw
51	1	Releasable Tie	102	1	Console Base

Key No.	Qty.	Description	Key No.	Qty.	Description
103	1	Key/Clip	133	2	Isolator Top Cap
104	4	Wheel Spacer	134	2	Isolator Spring
105	1	Console Insert	135	2	Isolator
106	1	Console Cover	136	2	Isolator Bottom Cap
107	1	Book Holder	137	2	Front Isolator
108	1	Filter Wire	138	2	Cushion Rod Clips
109	1	Frame Belly Pan	139	1	Cushion Motor Nut
110	1	Hood Foam, Right	140	2	Cushion Adj. Pin
111	1	Allen Wrench	141	2	Cushion Adj. Wheel
112	2	Short Console Bolt	142	1	Cushion Adj. Rod
113	1	Upright Ground Wire	143	2	Cushion Adj. Gear
114	1	Rail Cover, Left	144	10	Belly Pan Clip
115	1	Rail Cover, Right	145	1	Circuit Board Bracket
116	2	Static Decal	146	1	Cushion Sensor
117	1	Pulse Extension Wire	147	1	Magnet Plate
118	2	Idler Pulley Washer	148	1	Circuit Board
119	1	Idler Pulley	149	2	Isolator Screw
120	1	Idler Pulley Bolt	150	1	Cushion Adj. Motor
121	1	Idler Arm Bolt	151	4	Plastic Stand-Off
122	1	Idler Bushing	#	1	22" Blue Wire, M/F
123	1	Idler Arm	#	1	12" Blue Wire, 2F
124	1	Idler Arm Spring	#	1	4" Blue Wire, M/F
125	1	Cushion Motor Bolt	#	1	8" Green Wire, F/Ring
126	1	Handrail Coupler	#	1	8" Black Wire, 2 Ring
127	4	Pulse Bar Bolt	#	1	User's Manual
128	2	Control Knob			
129	1	Cushion Magnet			*Includes all parts shown in box
130	4	Spring Bolt			
131	2	Spring Pad Screw			#These parts are not illustrated
132	2	Gear Rack			Specifications are subject to change without notice.

## ORDERING REPLACEMENT PARTS

To order replacement parts, call our Customer Service Department toll-free at 1-888-825-2588, Monday through Friday, 6 a.m. until 6 p.m. Mountain Time (excluding holidays). When ordering parts, please be prepared to give the following information:

- the MODEL NUMBER OF THE PRODUCT (NTL14950)
- the NAME OF THE PRODUCT (NordicTrack® C2420 treadmill)
- the SERIAL NUMBER OF THE PRODUCT (see the front cover of this manual)
- the KEY NUMBER AND DESCRIPTION OF THE PART(S) (see the PART LIST on pages 34 and 35 and the EXPLODED DRAWING attached in the center of this manual)

**EXPLODED DRAWING—Model No. NTL14950**

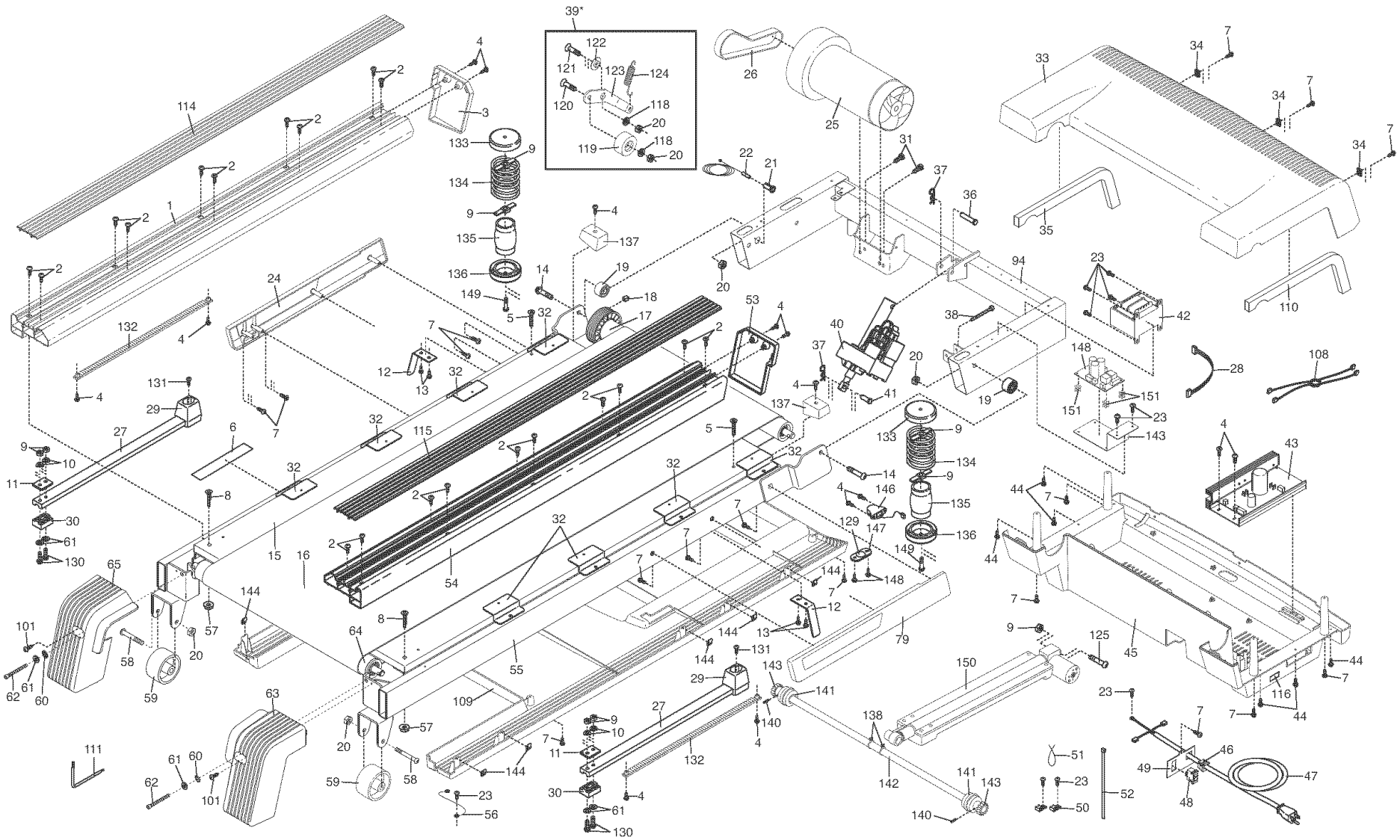

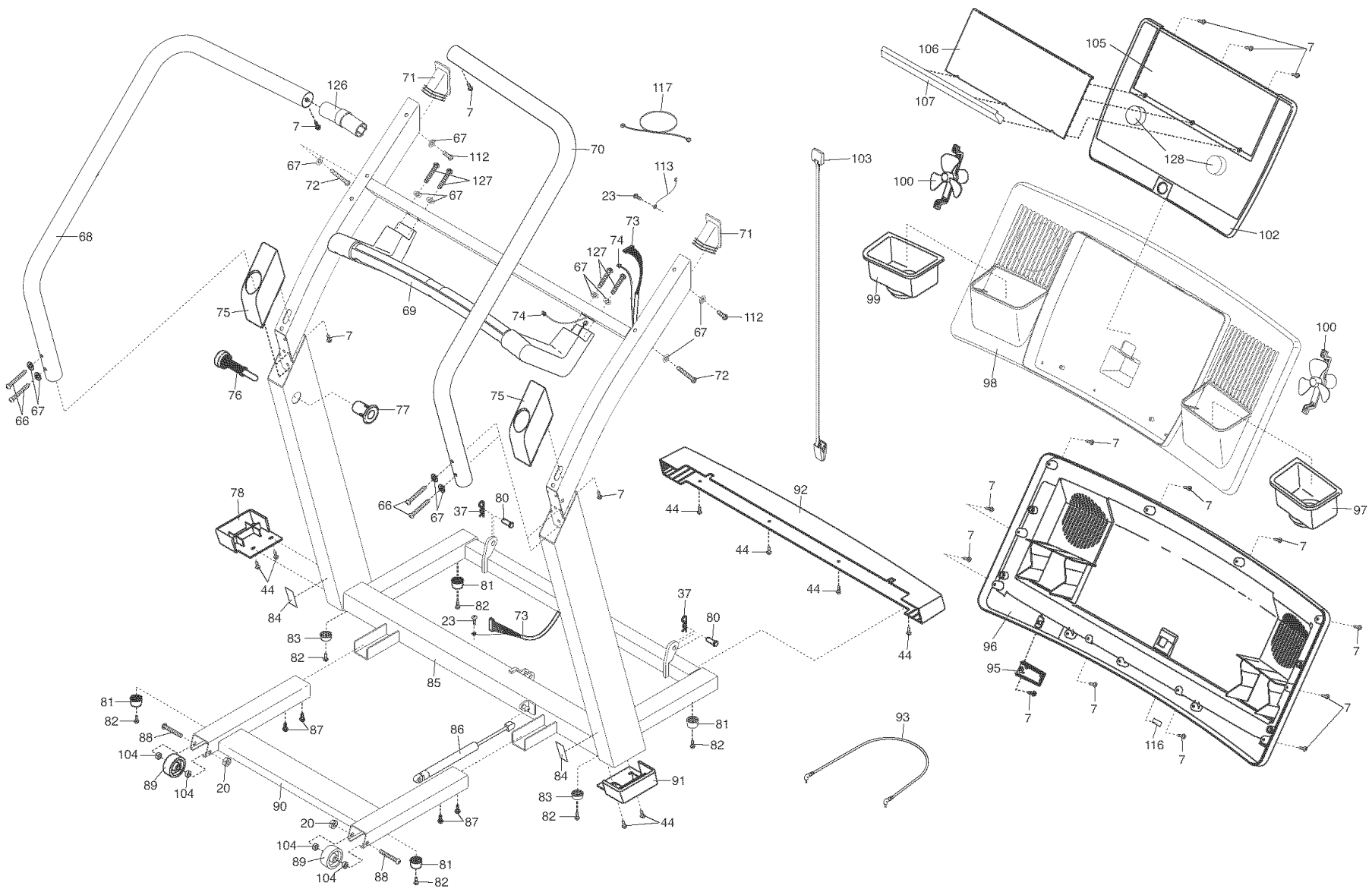

**EXPLODED DRAWING—Model No. NTL14950**

R1204B

## LIMITED WARRANTY

**WHAT IS COVERED**—The entire NordicTrack® C2420 treadmill (“Product”) is warranted to be free of all defects in material and workmanship.

**WHO IS COVERED**—The original purchaser or any person receiving the Product as a gift from the original purchaser.

**HOW LONG IS IT COVERED**—ICON Health & Fitness, Inc. (“ICON”), warrants the drive motor for life. Parts and labor are warranted for one year from the date of purchase.

**WHAT WE DO TO CORRECT COVERED DEFECTS**—We will ship to you, without charge, any replacement part or component, providing the repairs are authorized by ICON first and are performed by an ICON trained and authorized service provider, or, at our option, we will replace the Product.

**WHAT IS NOT COVERED**—Any failures or damage caused by unauthorized service, misuse, accident, negligence, improper assembly or installation, alterations, modifications without our written authorization or by failure on your part to use, operate, and maintain as set out in your User’s Manual (“Manual”). This warranty does not extend to products used for commercial or rental purposes.

**WHAT YOU MUST DO**—Always retain proof of purchase, such as your bill of sale; store, operate, and maintain the Product as specified in the Manual; notify our Customer Service Department of any defect within 10 days after discovery of the defect; as instructed, return any defected part for replacement or, if necessary, the entire product, for repair.

**USER’S MANUAL**—It is VERY IMPORTANT THAT YOU READ THE MANUAL before operating the Product. Remember to do the periodic maintenance requirements specified in the Manual to assure proper operation and your continued satisfaction.

**HOW TO GET PARTS AND SERVICE**—Simply call our Customer Service Department at 1-888-825-2588 and tell them your name and address and the serial number of your Product. They will tell you how to get a part replaced, or if necessary, arrange for service where your Product is located or advise you how to ship the Product for service. Before shipping, always obtain a Return Authorization Number (RA No.) from our Customer Service Department; securely pack your Product (save the original shipping carton if possible); put the RA No. on the outside of the carton and insure the product. Include a letter explaining the product or problem and a copy of your proof of purchase if you believe the service is covered by warranty.

ICON is not responsible or liable for indirect, special or consequential damages arising out of or in connection with the use or performance of the product or damages with respect to any economic loss, loss of property, loss of revenues or profits, loss of enjoyment or use, costs of removal, installation or other consequential damages of whatsoever nature. Some states do not allow the exclusion or limitation of incidental or consequential damages. Accordingly, the above limitation may not apply to you.

The warranty extended hereunder is in lieu of any and all other warranties and any implied warranties of merchantability or fitness for a particular purpose is limited in its scope and duration to the terms set forth herein. Some states do not allow limitations on how long an implied warranty lasts. Accordingly, the above limitation may not apply to you.

No one is authorized to change, modify or extend the terms of this limited warranty.

This warranty gives you specific legal rights and you may have other rights which vary from state to state.

**ICON HEALTH & FITNESS, INC., 1500 S. 1000 W., LOGAN, UT 84321-9813**