

# PRO-FORM XP 800 VF

Model No. 831.295550

Serial No. \_\_\_\_\_

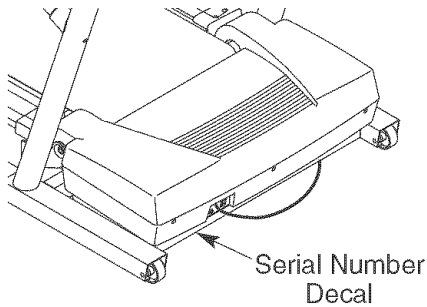

- Assembly
- Operation
- Maintenance
- Part List and Drawing

## **CAUTION**

Read all precautions and instructions in this manual before using this equipment. Save this manual for future reference.

## TREADMILL EXERCISER User's Manual

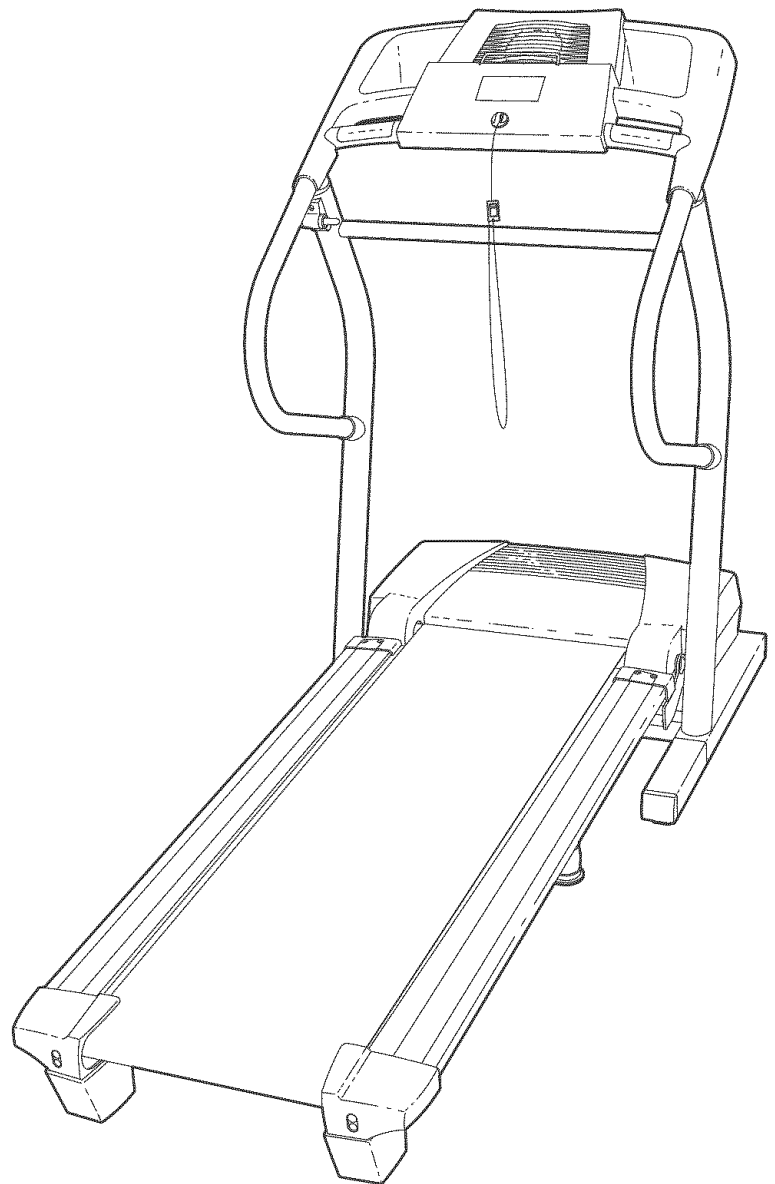

Sears, Roebuck and Co., Hoffman Estates, IL 60179

# PRO-FORM XP 800VF

---

## TABLE OF CONTENTS

IMPORTANT PRECAUTIONS .....	3
BEFORE YOU BEGIN .....	5
ASSEMBLY .....	6
OPERATION AND ADJUSTMENT .....	10
HOW TO FOLD AND MOVE THE TREADMILL .....	23
TROUBLESHOOTING .....	25
CONDITIONING GUIDELINES .....	27
ORDERING REPLACEMENT PARTS .....	Back Cover
FULL 90 DAY WARRANTY .....	Back Cover

Note: An EXPLODED DRAWING and a PART LIST are attached in the center of this manual.

# IMPORTANT PRECAUTIONS

**▲ WARNING:** To reduce the risk of burns, fire, electric shock, or injury to persons, read the following important precautions and information before operating the treadmill.

1. It is the responsibility of the owner to ensure that all users of this treadmill are adequately informed of all warnings and precautions.
2. Use the treadmill only as described.
3. Place the treadmill on a level surface, with at least eight feet of clearance behind it and two feet on each side. Do not place the treadmill on any surface that blocks air openings. To protect the floor or carpet from damage, place a mat under the treadmill.
4. Keep the treadmill indoors, away from moisture and dust. Do not put the treadmill in a garage or covered patio, or near water.
5. Do not operate the treadmill where aerosol products are used or where oxygen is being administered.
6. Keep children under the age of 12 and pets away from the treadmill at all times.
7. The treadmill should be used only by persons weighing 300 pounds or less.
8. Never allow more than one person on the treadmill at a time.
9. Wear appropriate exercise clothes when using the treadmill. Do not wear loose clothes that could become caught in the treadmill. Athletic support clothes are recommended for both men and women. *Always wear athletic shoes. Never use the treadmill with bare feet, wearing only stockings, or in sandals.*
10. When connecting the power cord (see page 10), plug the power cord into a surge suppressor (not included) and plug the surge suppressor into a grounded circuit capable of carrying 15 or more amps. No other appliance should be on the same circuit. Do not use an extension cord.
11. Use only a single-outlet surge suppressor that meets all of the specifications described on page 10. To purchase a surge suppressor, see your local Sears store or call 1-800-366-7278 and order part number 146148, or see your local electronics store.
12. Failure to use a properly functioning surge suppressor could result in damage to the control system of the treadmill. If the control system is damaged, the walking belt may change speed, accelerate, or stop unexpectedly, which may result in a fall and serious injury.
13. Keep the power cord and the surge suppressor away from heated surfaces.
14. Never move the walking belt while the power is turned off. Do not operate the treadmill if the power cord or plug is damaged, or if the treadmill is not working properly. (See TROUBLESHOOTING on page 25 if the treadmill is not working properly.)
15. Never start the treadmill while you are standing on the walking belt. Always hold the handrails while using the treadmill.
16. The treadmill is capable of high speeds. Adjust the speed in small increments to avoid sudden jumps in speed.
17. The pulse sensor is not a medical device. Various factors, including your movement, may affect the accuracy of heart rate readings. The sensor is intended only as an exercise aid in determining heart rate trends in general.
18. Never leave the treadmill unattended while it is running. Always remove the key and unplug the power cord when the treadmill is not in use.
19. Do not attempt to raise, lower, or move the treadmill until it is properly assembled. (See ASSEMBLY on page 6, and HOW TO FOLD AND MOVE THE TREADMILL on page 23.) You must be able to safely lift 45 pounds (20 kg) to raise, lower, or move the treadmill.
20. When folding or moving the treadmill, make sure that the storage latch is fully closed.

21. When using iFIT.com programs, an electronic “chirping” sound will alert you when the speed and/or incline of the treadmill is about to change. Always listen for the “chirp” and be prepared. In some instances, the speed and/or incline may change before the personal trainer describes the change.

22. When using iFIT.com programs, you can manually override the speed and incline settings by pressing the speed and incline buttons. However, when the next “chirp” is heard, the speed and/or incline will change to the next settings of the CD or video program.

23. Remove iFIT.com CDs and videos from your CD player and VCR and disconnect your MP3 player when you are not using them.

24. Inspect and properly tighten all parts of the treadmill regularly.

25. Never insert any object into any opening.

26. **DANGER:** Always unplug the power cord immediately after use, before cleaning the treadmill, and before performing the maintenance and adjustment procedures described in this manual. Never remove the motor hood unless instructed to do so by an authorized service representative. Servicing other than the procedures in this manual should be performed by an authorized service representative only.

27. This treadmill is intended for in-home use only. Do not use this treadmill in a commercial, rental, or institutional setting.

**⚠ WARNING:** Before beginning this or any exercise program, consult your physician. This is especially important for persons over the age of 35 or persons with pre-existing health problems. Read all instructions before using. Sears assumes no responsibility for personal injury or property damage sustained by or through the use of this product.

## SAVE THESE INSTRUCTIONS

The decals shown have been placed on your treadmill. If a decal is missing, or if it is not legible, please call toll-free 1-888-533-1333 and order a free replacement decal (see the front cover of this manual). Apply the decal in the location shown. Note: The decals are not shown at actual size.

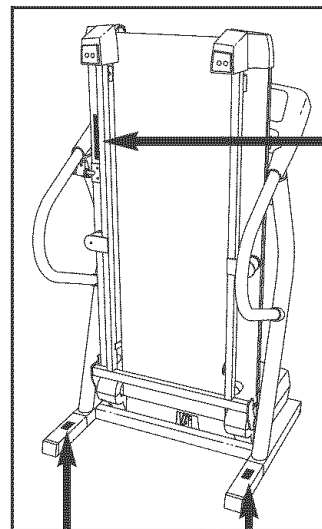
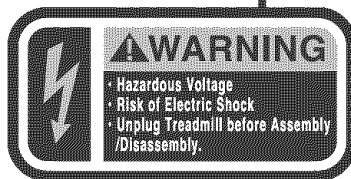
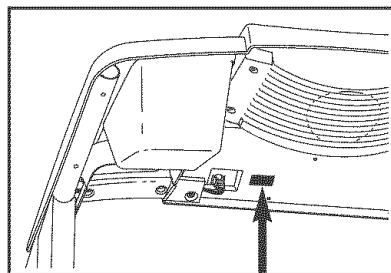

**⚠ WARNING:**  
Protect yourself and others from risk of serious injury. Read the user's manual and:

- Stand only on the side rails when starting or stopping treadmill.
- Change speed in small increments.
- Hold handrails to prevent falling, and always wear the safety clip while operating treadmill.
- Stop if you feel faint, dizzy, or short of breath.
- Fully engage storage latch before treadmill is moved or stored.
- Reduce incline to its lowest level before folding treadmill into storage position.
- Never allow children on or around treadmill.
- Remove key when not in use.
- Keep clothing, fingers, and hair away from moving belt.
- Never try to adjust or fix the belt while it is moving.
- Always wear athletic shoes while operating treadmill.

# BEFORE YOU BEGIN

Congratulations for purchasing the PROFORM® XP 800 VF treadmill. The XP 800 VF treadmill offers a selection of features designed to help you achieve your fitness goals in the convenience of your home. And when you're not exercising, the treadmill can be folded away, taking less than half the floor space of conventional treadmills.

**For your benefit, read this manual carefully before using the treadmill.** If you have questions after reading

this manual, call 1-800-4-MY-HOME® (1-800-469-4663). To help us assist you, please note the product model number and serial number before calling. The model number of the treadmill is 831.295550. The serial number can be found on a decal attached to the treadmill (see the front cover of this manual for the location).

Before reading further, please familiarize yourself with the parts that are labeled in the drawing below.

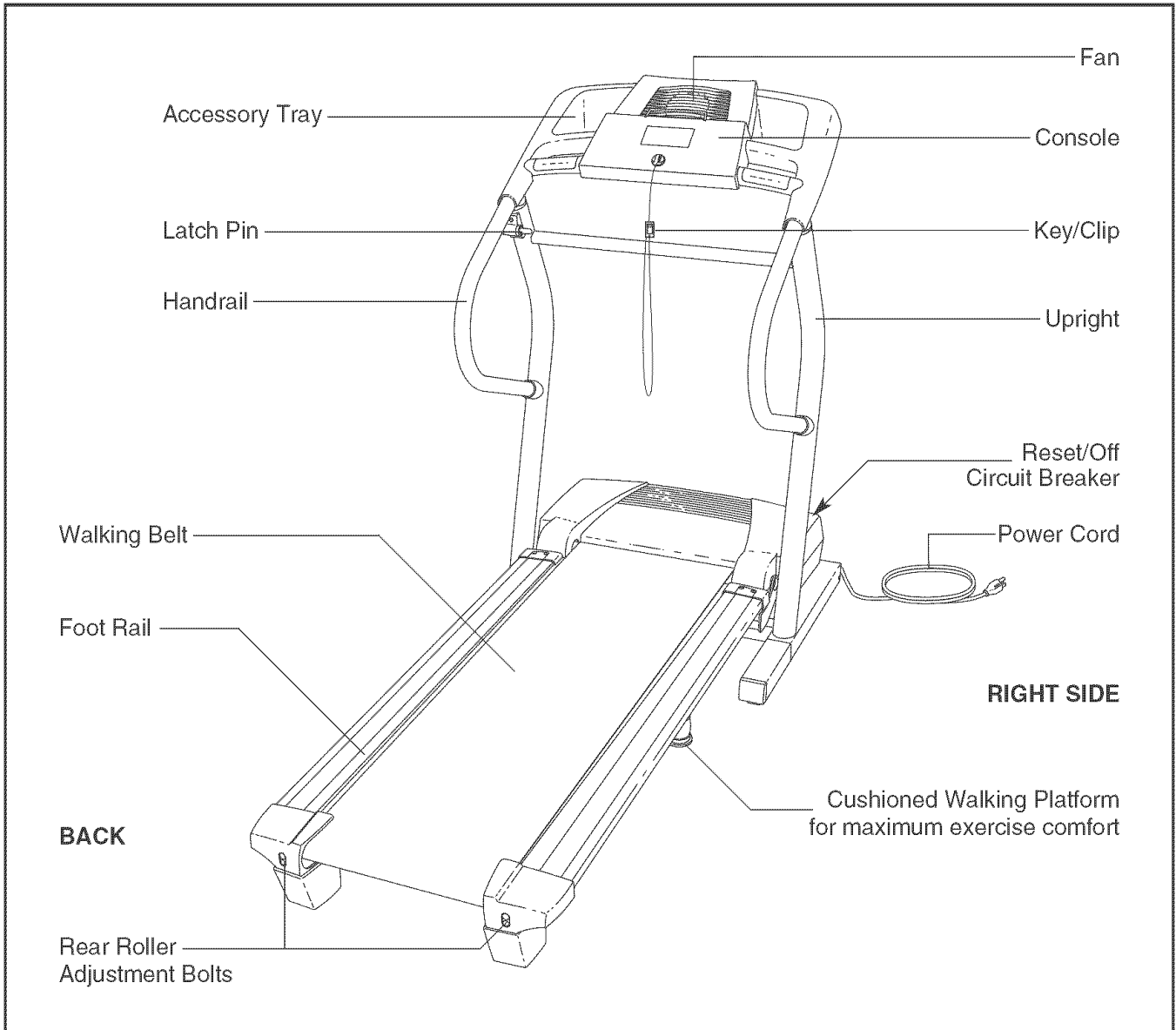

# ASSEMBLY

**Assembly requires two persons.** Set the treadmill in a cleared area and remove all packing materials. Do not dispose of the packing materials until assembly is completed.

Note: The underside of the treadmill walking belt is coated with high-performance lubricant. During shipping, a small amount of lubricant may be transferred to the top of the walking belt or the shipping carton. This is a normal condition and does not affect treadmill performance. If there is lubricant on top of the walking belt, simply wipe off the lubricant with a soft cloth and a mild, non-abrasive cleaner.

Assembly requires the included allen wrenches  and your own phillips screwdriver , rubber mallet , and adjustable wrench .

For help identifying the assembly hardware, see the drawings below. If a part is not in the parts bag, first check to see if it has been pre-assembled. If a part is missing, call toll-free 1-888-533-1333.

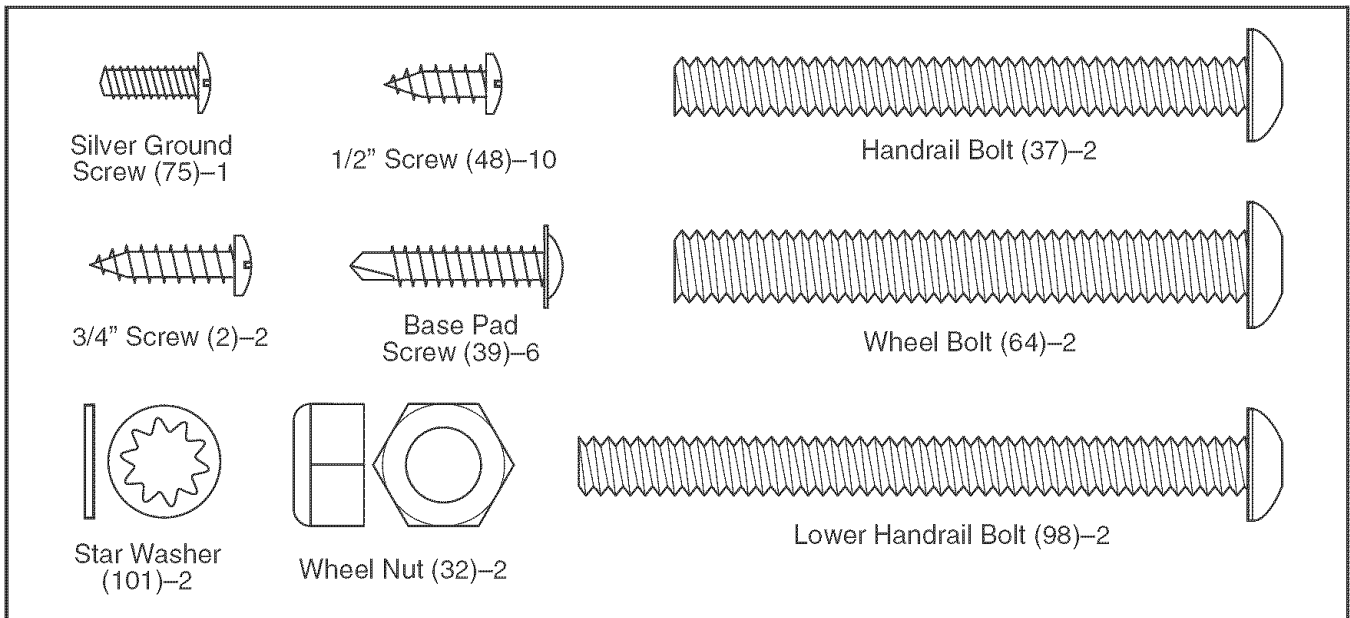

1. Make sure that the power cord is unplugged.



With the help of another person, carefully raise the Uprights (69) to the vertical position. Orient one of the Extension Legs (63) so that the Base Pad (61) is underneath it, and insert the Extension Leg into the treadmill as shown. Note: It may be helpful to tip the Uprights as you insert the Extension Leg.

Insert the other Extension Leg (63) in the same way.

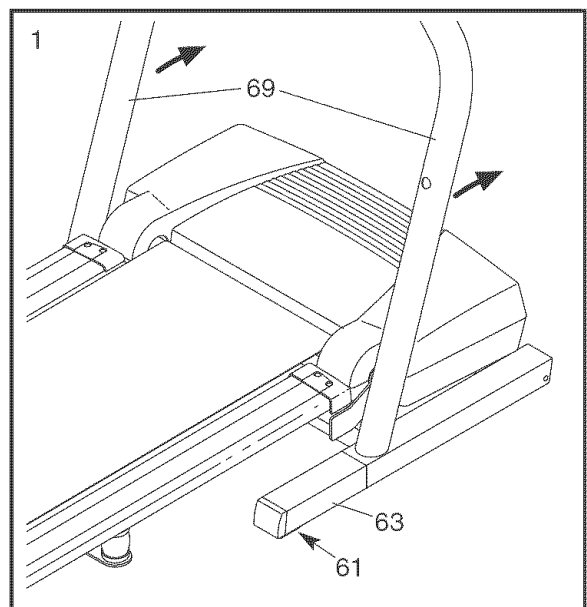

- Attach the Latch Housing (29) to the left Upright (69) with two 3/4" Screws (2). **Note: Make sure the large hole in the Housing is on the indicated side.** Next, remove the knob from the pin. Make sure that the collar and the spring are on the pin. (Note: If there are two collars, place one on each side of the spring.) Insert the pin into the Latch Housing (29), and tighten the knob back onto the pin.

Cut any ties holding the Upright Wire (42) to the the Upright (69). Insert the Upright Wire through an Upright Cap (73). Press the Upright Cap onto the right Upright (69). **Make sure that the ridges on the sides of the Upright Cap slide into the notches in the Upright.**

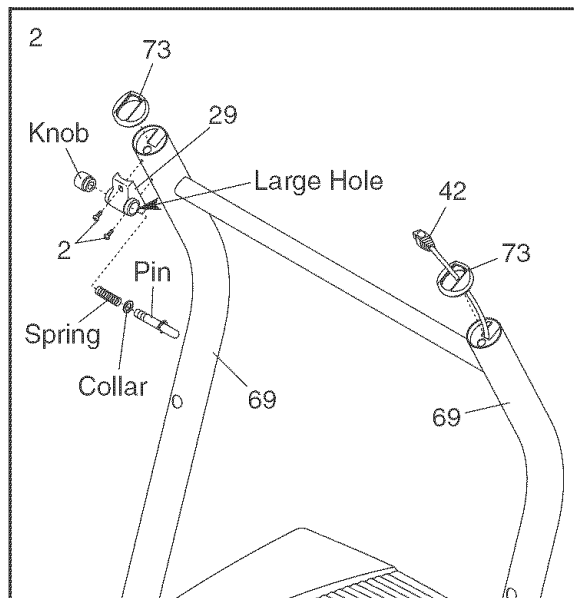

- Identify the Right Handrail (72), which has a large hole in the left side. Feed the Upright Wire (42) into the hole in the bottom of the Right Handrail and out of the large hole in the side. (Note: It may be helpful to use needle-nose pliers to pull the Upright Wire out of the hole.) Next, slide a Handrail Endcap (103) onto the lower end of the Right Handrail, and rotate the Handrail Endcap so that the small pin is at the top.

Attach the upper end of the Right Handrail (72) to the right Upright (69) with a Handrail Bolt (37). **Do not tighten the Handrail Bolt yet.** Attach the lower end of the Right Handrail with a Lower Handrail Bolt (98) and a Star Washer (101). **Tighten both Bolts.**

Attach the Left Handrail (71) as described above. Note: There is not an upright wire on the left side.

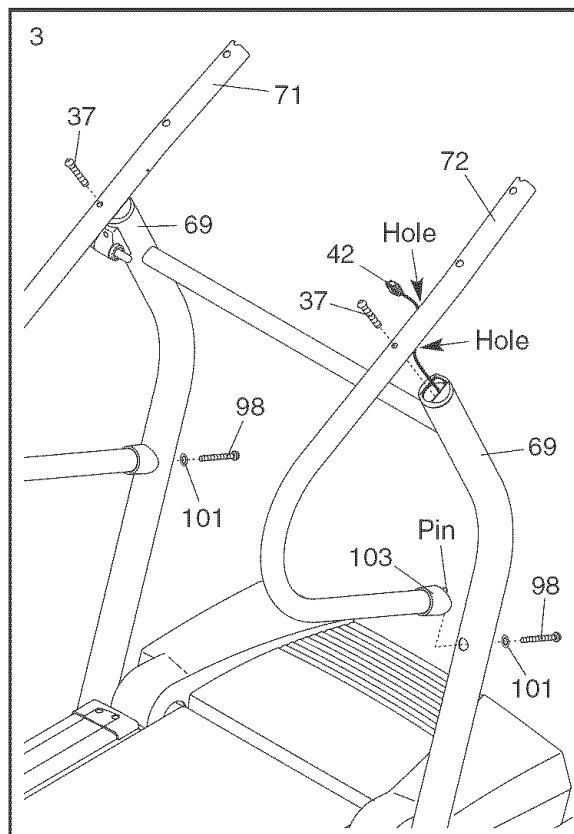

- With the help of another person, carefully lower the Uprights (69) as shown. Note: It may be helpful to place one foot on one of the Extension Legs (63) as you tip the Uprights. **Make sure that the Extension Legs remain in the Uprights.**

Attach each Extension Leg (63) with two Base Pad Screws (39) and a Base Pad (57) as shown. **Attach the lower Base Pad Screw, without the Base Pad, first.**

Attach two Base Pads (57) to the base of the Uprights (69) with two Base Pad Screws (39).

Next, attach the two Wheels (66) with two Wheel Bolts (64), four Wheel Spacers (108), and two Wheel Nuts (32) as shown. **Do not overtighten the Wheel Nuts;** the Wheels should turn freely.

With the help of another person, carefully raise the Uprights (69) to the vertical position.

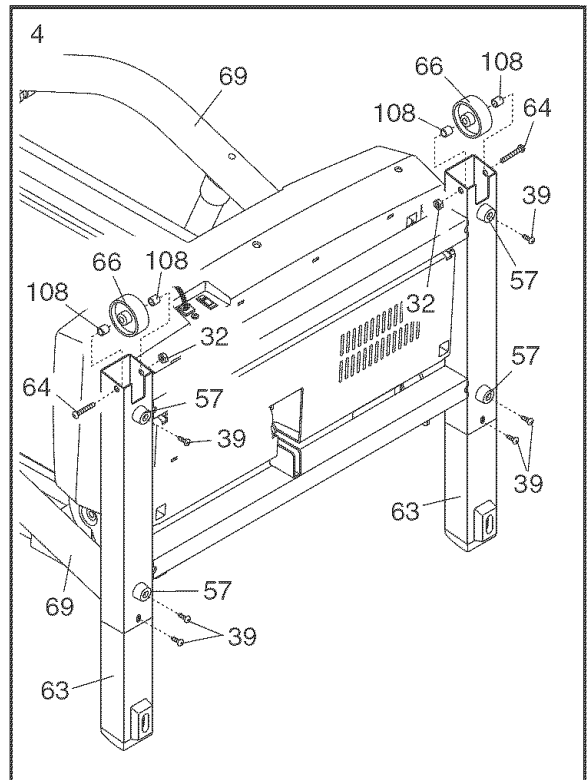

- Hold the Console Base (47) near the Left Handrail (71). Attach the two ground wires on the Console Base to the indicated small hole in the Left Handrail with the Silver Ground Screw (75).

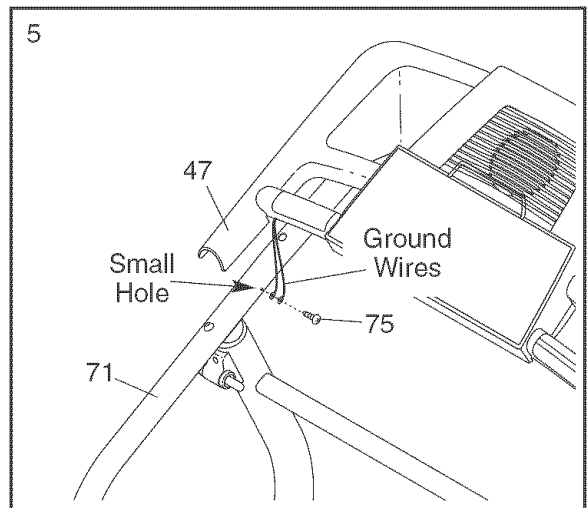

- Set the Console Base (47) on the Right Handrail (72) and the Left Handrail (71). Attach the Console Base with four 1/2" Screws (48). **Start all four Screws before tightening them; do not overtighten the Screws.**

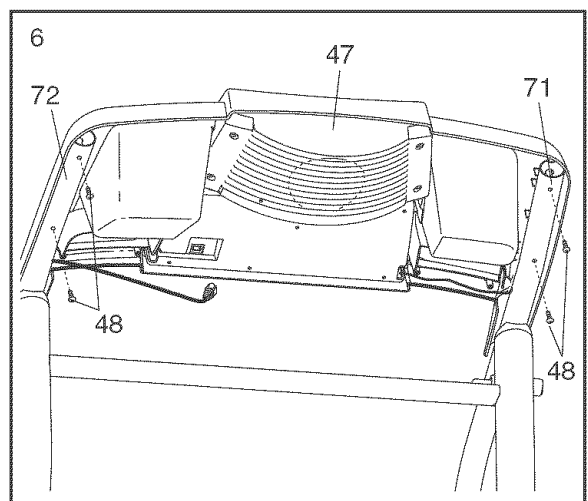



7. **Touch the Right Handrail (72) to discharge any static.** Press the end of the Upright Wire (42) into the socket in the bottom of the Console Base (47). **The connector should slide easily into the socket and snap into place.** If the connector does not slide easily and snap into place, turn the connector and then insert it.

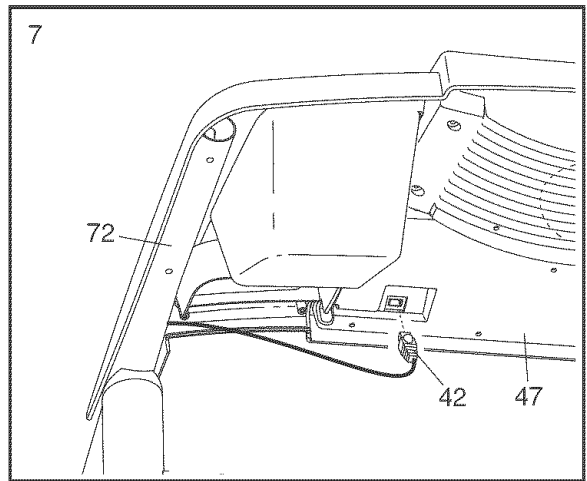

8. Press the Upright Wire (42) into the slot in the underside of the Console Base (47) in the indicated area. Cover the Upright Wire with the Right Grip Plate (36). **Be careful not to pinch the Upright Wire.** Tighten three 1/2" Screws (48) into the Right Grip Plate and the Console Base.

Attach the Left Grip Plate (32) over the ground wires and the other wires with three 1/2" Screws (48). **Be careful not to pinch any of the wires. If necessary, double up the ground wires before attaching the Left Ground Plate.**

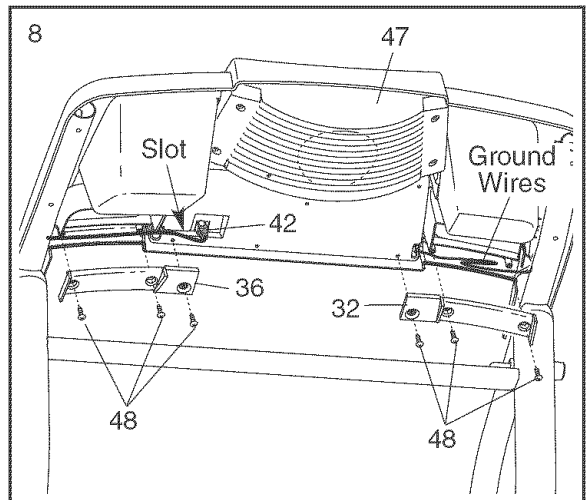

9. **Make sure that all parts are properly tightened before you use the treadmill.** Note: Extra hardware may be included. Keep the included allen wrenches in a secure place. The large allen wrench is used to adjust the walking belt (see page 26). To protect the floor or carpet, place a mat under the treadmill.

# OPERATION AND ADJUSTMENT

## THE PRE-LUBRICATED WALKING BELT

Your treadmill features a walking belt coated with high-performance lubricant. **IMPORTANT: Never apply silicone spray or other substances to the walking belt or the walking platform.** Such substances will deteriorate the walking belt and cause excessive wear.

## HOW TO PLUG IN THE POWER CORD

**▲ DANGER:** Improper connection of the equipment-grounding conductor can result in an increased risk of electric shock. Check with a qualified electrician or serviceman if you are in doubt as to whether the product is properly grounded. Do not modify the plug provided with the product—if it will not fit the outlet, have a proper outlet installed by a qualified electrician.

Your treadmill, like any other type of sophisticated electronic equipment, can be seriously damaged by sudden voltage changes in your home's power. Voltage surges, spikes, and noise interference can result from weather conditions or from other appliances being turned on or off. **To decrease the possibility of your treadmill being damaged, always use a surge suppressor with your treadmill (see drawing 1 at the right).** To purchase a surge suppressor, see your local Sears store or call 1-800-366-7278 and order part number 146148, or see your local electronics store.

Use only a single-outlet surge suppressor that is UL 1449 listed as a transient voltage surge suppressor (TVSS). The surge suppressor must have a UL suppressed voltage rating of 400 volts or less and a minimum surge dissipation of 450 joules. The surge suppressor must be electrically rated for 120 volts AC and 15 amps. There must be a monitoring light on the surge suppressor to indicate whether it is functioning properly. Failure to use a properly functioning surge suppressor could result in damage to the control system of the treadmill. If the control system is damaged, the walking belt may change speed, accelerate, or stop unexpectedly, which may result in a fall and serious injury.

**This product must be grounded.** If it should malfunction or break down, grounding provides a path of least resistance for electric current to reduce the risk of electric shock. This product is equipped with a cord having

an equipment-grounding conductor and a grounding plug. **Plug the power cord into a surge suppressor, and plug the surge suppressor into an appropriate outlet that is properly installed and grounded in accordance with all local codes and ordinances. Important: The treadmill is not compatible with GFCI-equipped outlets.**

This product is for use on a nominal 120-volt circuit, and has a grounding plug that looks like the plug illustrated in drawing 1 below. A temporary adapter that looks like the adapter illustrated in drawing 2 may be used to connect the surge suppressor to a 2-pole receptacle as shown in drawing 2 if a properly grounded outlet is not available.

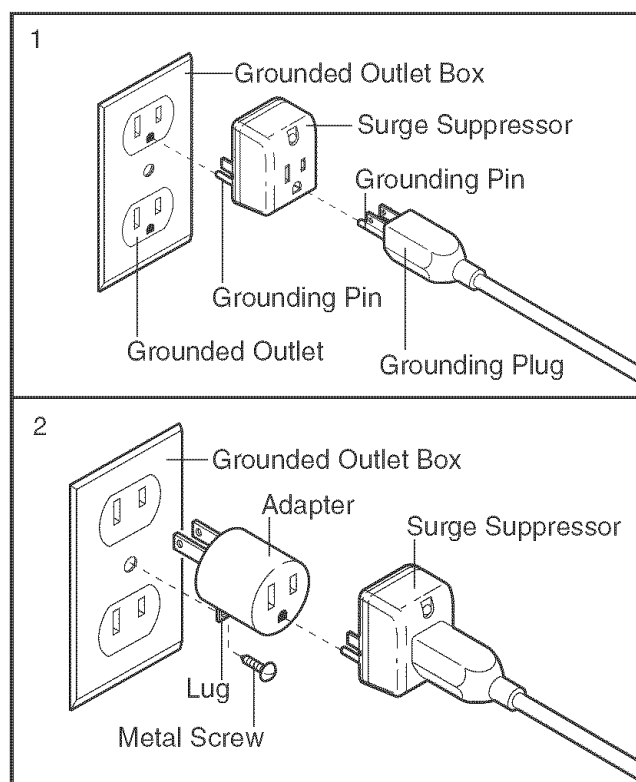

The temporary adapter should be used only until a properly grounded outlet (drawing 1) can be installed by a qualified electrician.

The green-colored rigid ear, lug, or the like extending from the adapter must be connected to a permanent ground such as a properly grounded outlet box cover. Whenever the adapter is used it must be held in place by a metal screw. **Some 2-pole receptacle outlet box covers are not grounded. Contact a qualified electrician to determine if the outlet box cover is grounded before using an adapter.**

## CONSOLE DIAGRAM

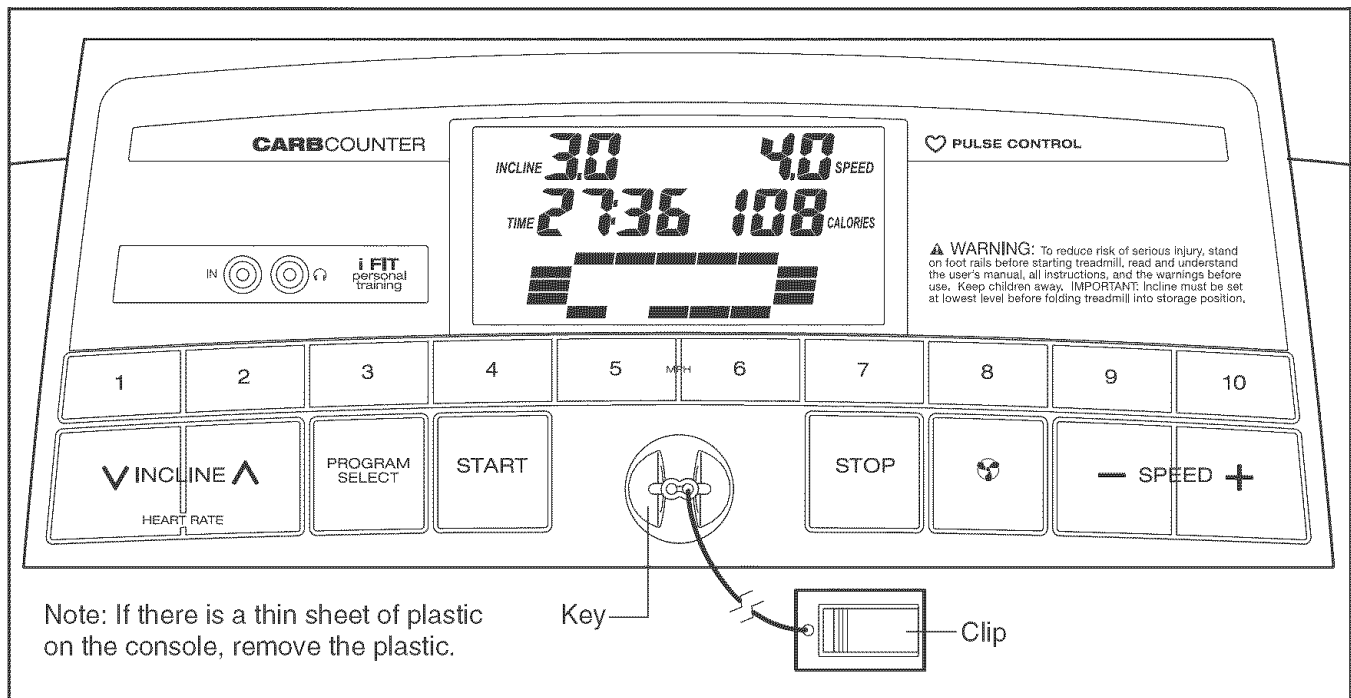

### FEATURES OF THE CONSOLE

The treadmill console offers an impressive array of features designed to help you get the most from your workouts.

When the manual mode of the console is selected, the speed and incline of the treadmill can be changed with the touch of a button. As you exercise, the console will display continuous exercise feedback. You can even measure your heart rate using the built-in handgrip pulse sensor.

In addition, the console features eight preset programs. Each program automatically controls the speed and incline of the treadmill to give you an effective workout. The console also offers two heart rate programs that control the speed and incline of the treadmill to keep your heart rate near a target heart rate during your workouts.

The console also features iFIT.com interactive technology. Having iFIT.com technology is like having a personal trainer in your home. Using a stereo audio cable,

you can connect the treadmill to your portable stereo, home stereo, computer, or VCR and play special iFIT.com MP3, CD, and video programs (iFIT.com MP3 programs, CDs, and videocassettes are available separately). iFIT.com programs automatically control the speed and incline of the treadmill as a personal trainer guides you through every step of your workout; high-energy music provides added motivation. **To download iFIT.com MP3 programs, go to [www.iFIT.com](http://www.iFIT.com). To purchase iFIT.com CDs or videocassettes, call toll-free 1-888-533-1333.**

With the treadmill connected to your computer, you can also go to [www.iFIT.com](http://www.iFIT.com) and access iFIT.com programs directly from our Web site. **See [www.iFIT.com](http://www.iFIT.com) for more information.**

**To use the manual mode of the console**, follow the steps beginning on page 12. **To use a preset program**, see page 14. **To use a heart rate program**, see page 15. **To use an iFIT.com MP3, CD, or video program**, see page 19. **To use an iFIT.com program directly from our Web site**, see page 21.

## HOW TO TURN ON THE POWER

**1** Plug in the power cord (see page 10).

**2** Locate the reset/off circuit breaker near the power cord. Make sure that the circuit breaker is in the reset position.

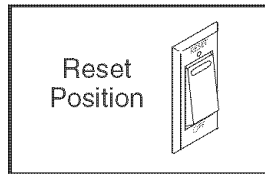

**3** Stand on the foot rails of the treadmill. Find the clip attached to the key (see the drawing on page 11) and slide the clip onto the waistband of your clothes. Next, insert the key into the console. After a moment, the display will light. **Test the clip by carefully taking a few steps backward until the key is pulled from the console. If the key is not pulled from the console, adjust the position of the clip as needed.**

walking belt as desired by pressing the Speed + and – buttons. Each time a button is pressed, the speed setting will change by 0.1 mph; if a button is held down, the speed setting will change in increments of 0.5 mph. Note: After the buttons are pressed, it may take a moment for the walking belt to reach the selected speed setting.

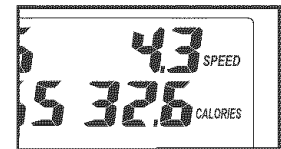

If one of the quick speed buttons is pressed, the walking belt will gradually increase in speed until it reaches the selected speed setting.

To stop the walking belt, press the Stop button. The time will begin to flash in the display. To restart the walking belt, press the Start button, the Speed + button, or one of the quick speed buttons.

Note: The first time the treadmill is used, observe the alignment of the walking belt, and align the walking belt if necessary (see page 26).

## HOW TO USE THE MANUAL MODE

**1** Insert the key into the console.

See HOW TO TURN ON THE POWER above.

**2** Select the manual mode.

When the key is inserted, the manual mode will be selected. If a program has been selected, reselect the manual mode by pressing the Program Select button repeatedly until a track appears in the lower part of the display; make sure that the letters "iFIT" do not appear in the display.

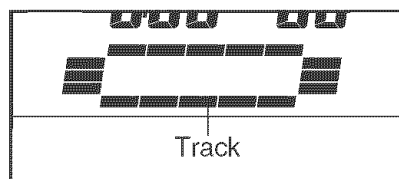

**3** Start the walking belt.

To start the walking belt, press the Start button, the Speed + button, or one of the ten quick speed buttons.

If the Start button or the Speed + button is pressed, the walking belt will begin to move at 1 mph. As you exercise, change the speed of the

**4** Change the incline of the treadmill as desired.

To change the incline of the treadmill, press the Incline increase and decrease buttons. Each time a button is pressed, the incline will change by 0.5%. Note: After the buttons are pressed, it may take a moment for the treadmill to reach the selected incline setting.

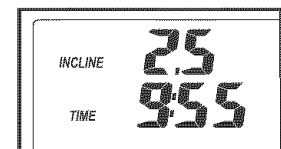

**5** Follow your progress with the display.

When the manual mode or the iFIT.com mode is selected, the lower part of

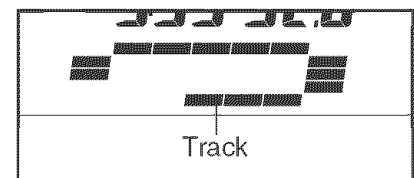

the display will show a 1/4-mile track. As you walk or run, the indicators around the track will appear in succession until the entire track appears. The track will then disappear and the indicators will again begin to appear in succession.

The left side of the display will show the incline level of the treadmill, the elapsed time, the approximate number of grams of carbs you have burned, and the distance you have walked or run. Note: Each time the incline changes, the display will show the incline setting for a few seconds. When a program is selected, the display will show the time remaining in the program instead of the elapsed time.

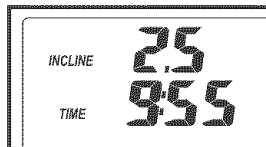

The right side of the display will show the speed of the walking belt, the approximate number of calories you have burned, and your pace (in minutes per mile). The display will also show your heart rate when you use the handgrip pulse sensor.

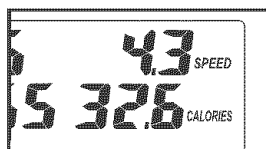

Note: The console can display speed and distance in either miles or kilometers. To determine which unit of measurement is selected, hold down the Stop button while inserting the key into the console. An "E" for English miles or an "M" for metric kilometers will appear in the right side of the display. Press the Speed + button to change the unit of measurement. When the desired unit of measurement is selected, remove the key. **Note: For simplicity, all instructions in this section refer to miles.**

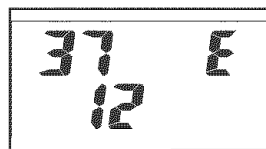

To reset the display, press the Stop button, remove the key, and then reinsert the key.

## 6 Measure your heart rate if desired.

Note: Before using the handgrip pulse sensor, make sure that your hands are clean. If there are

sheets of clear plastic on the metal contacts on the handgrip pulse sensor, remove the plastic.

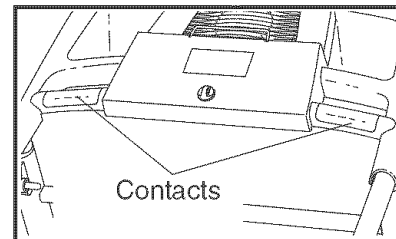

To measure your heart rate, **stand on the foot rails** and hold the metal contacts on the handgrip pulse sensor—**avoid moving your hands**. When your pulse is detected, the heart symbol in the right side of the display will appear, one or two dashes will appear, and then your heart rate will be shown. **For the most accurate heart rate reading, continue to hold the contacts for about 15 seconds.**

## 7 Turn on the fan if desired.

To turn on the fan, press the fan button (the fan button is located beside the Stop button). To turn on the fan at high speed, press the button a second time. To turn off the fan, press the button a third time. Note: A few minutes after the walking belt is stopped, the fan will automatically turn off.

## 8 When you are finished exercising, remove the key.

Step onto the foot rails, press the Stop button, and **adjust the incline of the treadmill to the lowest setting. The incline must be at the lowest setting when the treadmill is folded to the storage position or the treadmill will be damaged.** Next, remove the key from the console and put it in a secure place. **Note: If the display remains lit after the key is removed, the console is in the "demo" mode. See page 22 and turn off the demo mode.**

**When you are finished using the treadmill, switch the reset/off circuit breaker to the "off" position and unplug the power cord.**

## HOW TO USE A PRESET PROGRAM

### 1 Insert the key fully into the console.

See HOW TO TURN ON THE POWER on page 12.

### 2 Select a preset program.

To select one of the eight preset programs, press the Program Select button repeatedly. As

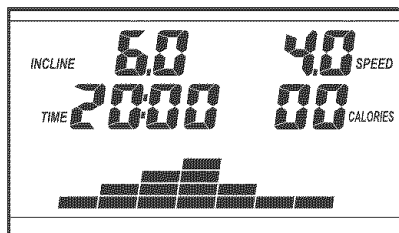

each preset program is selected, the maximum speed setting of the program and the maximum incline setting of the program will flash in the display for a few seconds. The display will also show how long the program will last. The matrix in the lower part of the display will show the first seven speed settings of the program.

### 3 Press the Start button or the Speed + button to start the program.

A moment after the button is pressed, the treadmill will automatically adjust to the first speed and incline settings for the program. Hold the handrails and begin walking.

Each program is divided into either 20 or 30 one-minute segments. One speed setting and one incline setting are programmed for each segment. Note: The same speed setting and/or incline setting may be programmed for two or more consecutive segments.

The speed setting for the first segment will be shown in the flashing Current

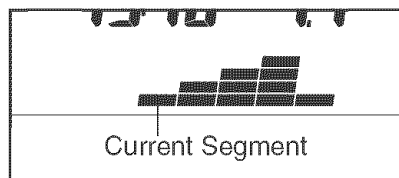

Segment column of the matrix in the lower part of the display. (The incline settings are not shown in the matrix.) The speed settings for the next four segments will be shown in the four columns to the right.

When only three seconds remain in the first segment of the program, both the Current Segment column and the column to the right will flash and a series of tones will sound. If the speed and/or incline of the treadmill is about to change, the speed setting and/or the incline setting will flash in the display to alert you.

When the first segment is completed, *all speed settings will move one column to the left*. The speed setting for the second segment will then be shown in the flashing Current Segment column and the treadmill will automatically adjust to the speed and incline settings for the second segment. Note: If all five of the indicators in the Current Segment column are lit, *the speed settings may move downward* so that only the highest indicators appear in the matrix.

The program will continue in this way until the speed setting for the last segment is shown in the Current Segment column and the last segment ends. The walking belt will then slow to a stop.

If the speed or incline setting for the current segment is too high or too low, you can manually override the setting by pressing the Speed or Incline buttons. Every few times a Speed button is pressed, an additional indicator will appear or disappear in the Current Segment column; if any of the columns to the right of the Current Segment column have the same number of lit indicators as the Current Segment column, an additional indicator may appear or disappear in those columns as well. **Important: When the current segment of the program ends, the treadmill will automatically adjust to the speed and incline settings for the next segment.**

To stop the program at any time, press the Stop button. The time will begin to flash in the display. To restart the program, press the Start button or the Speed + button. The walking belt will begin to move at 1 mph. When the next segment of the program begins, the treadmill will automatically adjust to the speed and incline settings for the next segment.

**4** Follow your progress with the display.

See step 5 on page 12.

**5** Measure your heart rate if desired.

See step 6 on page 13.

**6** Turn on the fan if desired.

See step 7 on page 13.

**7** When you are finished exercising, remove the key from the console.

When the program has ended, **make sure that the incline of the treadmill is at the lowest setting.** Next, remove the key from the console and put it in a safe place. **Note: If the display remains lit after the key is removed, the console is in the “demo” mode. See page 22 and turn off the demo mode.**

When you are finished using the treadmill, **switch the reset/off circuit breaker to the “off” position and unplug the power cord.**

## HOW TO USE A HEART RATE PROGRAM

**⚠ CAUTION:** If you have heart problems, or if you are over 60 years of age and have been inactive, do not use the heart rate programs. If you are taking medication regularly, consult your physician to find whether the medication will affect your exercise heart rate.

**1** Insert the key into the console.

See HOW TO TURN ON THE POWER on page 12.

**2** Select a heart rate program.

To select a heart rate program, press the Program Select button repeatedly. The display will show

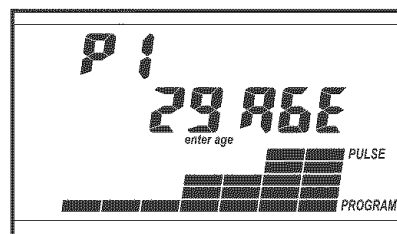

which program (“P1” or “P2”) is selected. When a heart rate program is selected, the matrix in the lower part of the display will show the first seven target heart rate settings of the program.

**3** Enter your age.

When a heart rate program is selected, the word “AGE” will appear in the display and the current age setting will begin to flash. If you have already entered your age, simply press the Start button (the program will not start at this time). If you have not entered your age, press the Speed + and – buttons to enter your age, and then press the Start button.



**4** Enter a maximum speed setting.

After you have entered your age, the letters “SPd” will appear in the display and the maximum speed setting of the program will begin to flash. If desired, press the Speed + and – buttons to change the maximum speed setting. Then, press the Start button (the program will not start at this time).



**5 Enter a maximum target heart rate setting.**

After you have entered a maximum speed setting, the letters "PLS" and the current maximum target heart rate setting of the program will appear in the display. Press the Heart Rate increase and decrease buttons to change the maximum target heart rate setting (see **EXERCISE INTENSITY** on page 27).

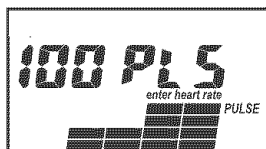

**6 Hold the handgrip pulse sensor.**

To use a heart rate program, you must hold the handgrip pulse sensor. It is not necessary to hold the pulse sensor continuously during the program; however, you should hold the pulse sensor frequently for the program to operate properly. **Each time you hold the pulse sensor, keep your hands on the metal contacts for at least 30 seconds.** Note: When you are not holding the pulse sensor, the letters "PLS" will appear in the display instead of your heart rate.

**7 Press the Start button or the Speed + button to start the program.**

A moment after the button is pressed, the treadmill will automatically adjust to the first speed and incline settings of the program. Hold the handrails and begin walking.

Each heart rate program is divided into either 20 or 30 one-minute segments. One target heart rate is programmed for each segment. Note: The same target heart rate may be programmed for two or more consecutive segments.

The target heart rate setting for the first segment will be shown in the flashing

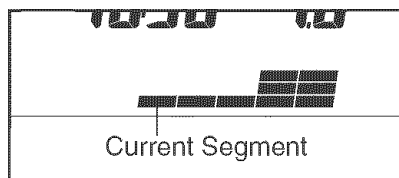

Current Segment column of the matrix. The target heart rate settings for the next four segments will be shown in the columns to the right.

When only three seconds remain in the first segment of the program, both the Current Segment column and the column to the right will flash and a series of tones will sound. In addition, the speed

setting and the incline setting will flash in the display to alert you. When the first segment ends, *all target heart rate settings will move one column to the left.* The target heart rate setting for the second segment will then be shown in the flashing Current Segment column.

During each segment, the console will compare your heart rate to the target heart rate. If your heart rate is too far below or above the target heart rate, the speed of the walking belt will automatically increase or decrease to bring your heart rate closer to the target heart rate. If the speed reaches the maximum speed setting of the program (see step 4 on page 15) and your heart rate is still too far below the target heart rate, the incline of the treadmill will also increase to bring your heart rate closer to the target heart rate.

The program will continue in this way until the target heart rate setting for the last segment is shown in the Current Segment column and the last segment ends. The walking belt will then slow to a stop.

If the speed or incline setting is too high or too low at any time during the program, you can adjust the setting with the Speed or Incline buttons. However, each time the console compares your heart rate to the target heart rate, the speed and/or incline of the treadmill may automatically change to bring your heart rate closer to the target heart rate.

To stop the program at any time, press the Stop button. The time will begin to flash in the display. To restart the program, press the Start button or the Speed + button. The walking belt will begin to move at 1 mph. When the console compares your heart rate to the target heart rate, the speed and/or incline of the treadmill may automatically change.

**8 Follow your progress with the display.**

See step 5 on page 12.

**9 Turn on the fan if desired.**

See step 7 on page 13.

**10 When you are finished exercising, remove the key from the console.**

See step 7 on page 15.



## HOW TO CONNECT THE TREADMILL TO USE IFIT.COM PROGRAMS

To use iFIT.com MP3 or CD programs, the treadmill must be connected to your MP3 player, CD player, portable stereo, home stereo, or computer. See pages 17 and 18 for connecting instructions. To use iFIT.com programs directly from our Web site, the treadmill must be connected to your computer. See page 18 for connecting instructions. To use iFIT.com video programs, the treadmill must be connected to your VCR. See page 19 for connecting instructions.

## HOW TO CONNECT YOUR MP3 PLAYER OR CD PLAYER

- A. Plug one end of the included 1/8" to 1/8" stereo audio cable into the input jack on the console. Plug the other end of the cable into a jack on your MP3 player or CD player. Plug your headphones into the headphone jack on the console.

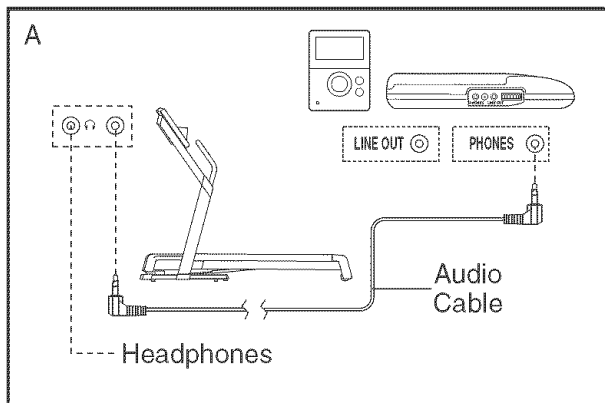

## HOW TO CONNECT YOUR PORTABLE STEREO

Note: If your stereo has an RCA-type AUDIO OUT jack, see instruction A below. If your stereo has a 1/8" LINE OUT jack, see instruction B. If your stereo has only a PHONES jack, see instruction C.

- A. Plug one end of a long 1/8" to RCA stereo audio cable (available at electronics stores) into the input jack on the console. Plug the other end of the cable into the AUDIO OUT jack on your stereo.

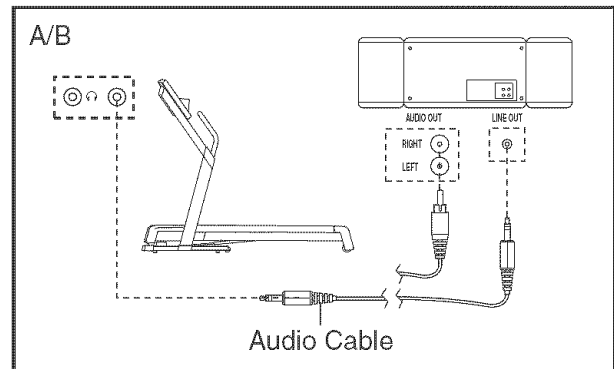

- B. See the drawing above. Plug one end of a long 1/8" to 1/8" stereo audio cable (available at electronics stores) into the input jack on the console. Plug the other end of the cable into the LINE OUT jack on your stereo. Note: While the cable is plugged into the LINE OUT jack, do not plug your headphones into the headphone jack on the console.

- C. Plug one end of a long 1/8" to 1/8" stereo audio cable (available at electronics stores) into the input jack on the console. Plug the other end of the cable into the PHONES jack on your stereo. Plug your headphones into the headphone jack on the console.

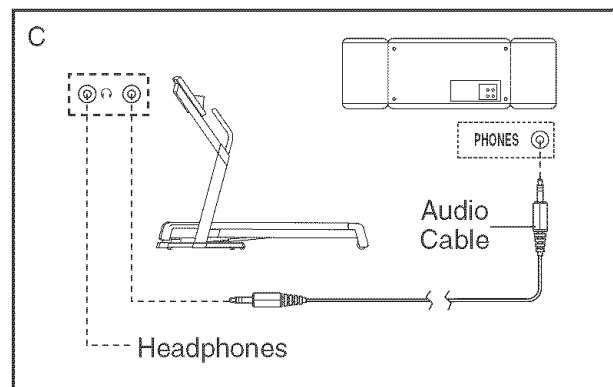

## HOW TO CONNECT YOUR HOME STEREO

**Note:** If your stereo has an unused **LINE OUT** jack, see instruction **A** below. If the **LINE OUT** jack is being used, see instruction **B**.

- A. Plug one end of a long 1/8" to RCA stereo audio cable (available at electronics stores) into the input jack on the console. Plug the other end of the cable into the **LINE OUT** jack on your stereo. Note: While the cable is plugged into the **LINE OUT** jack, do not plug your headphones into the headphone jack on the console.

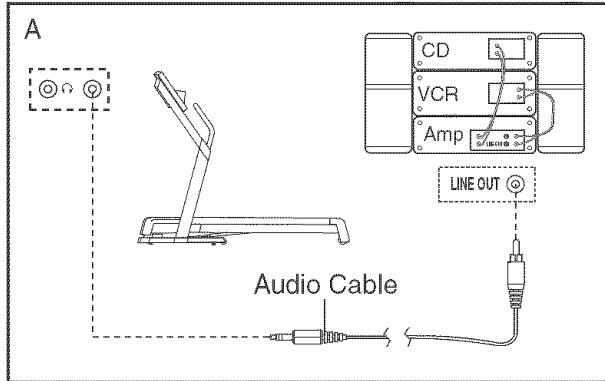

- B. Plug one end of a long 1/8" to RCA stereo audio cable (available at electronics stores) into the input jack on the console. Plug the other end of the cable into an RCA Y-adapter (available at electronics stores). Next, remove the wire that is currently plugged into the **LINE OUT** jack on your stereo and plug the wire into the unused side of the Y-adapter. Plug the Y-adapter into the **LINE OUT** jack on your stereo. Note: While the Y-adapter is plugged into the **LINE OUT** jack, do not plug your headphones into the headphone jack on the console.

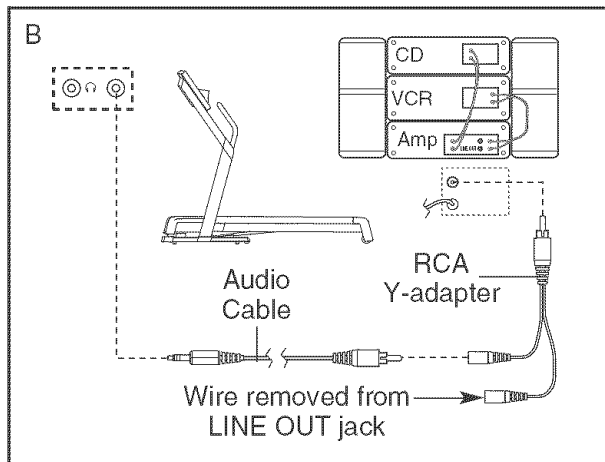

## HOW TO CONNECT YOUR COMPUTER

- A. Plug one end of a long 1/8" to 1/8" stereo audio cable (available at electronics stores) into the input jack on the console. Plug the other end of the cable into the **LINE OUT** jack on your computer. Note: While the cable is plugged into the **LINE OUT** jack, do not plug your headphones into the headphone jack on the console.

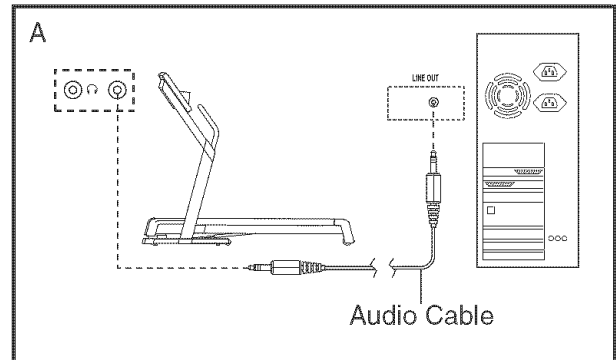

## HOW TO CONNECT YOUR VCR

**Note:** If your VCR has an unused AUDIO OUT jack, see instruction A below. If the AUDIO OUT jack is being used, see instruction B. If you have a TV with a built-in VCR, see instruction B. If your VCR is connected to your home stereo, see **HOW TO CONNECT YOUR HOME STEREO** on page 18.

- A. Plug one end of a long 1/8" to RCA stereo audio cable (available at electronics stores) into the input jack on the console. Plug the other end of the cable into the AUDIO OUT jack on your VCR.

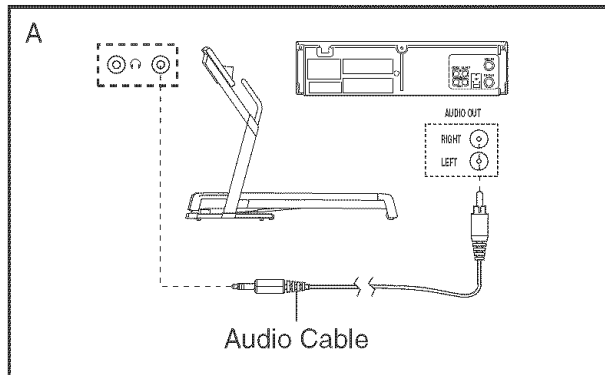

- B. Plug one end of a long 1/8" to RCA stereo audio cable (available at electronics stores) into the input jack on the console. Plug the other end of the cable into an RCA Y-adapter (available at electronics stores). Next, remove the wire that is currently plugged into the AUDIO OUT jack on your VCR and plug the wire into the unused side of the Y-adapter. Plug the Y-adapter into the AUDIO OUT jack on your VCR.

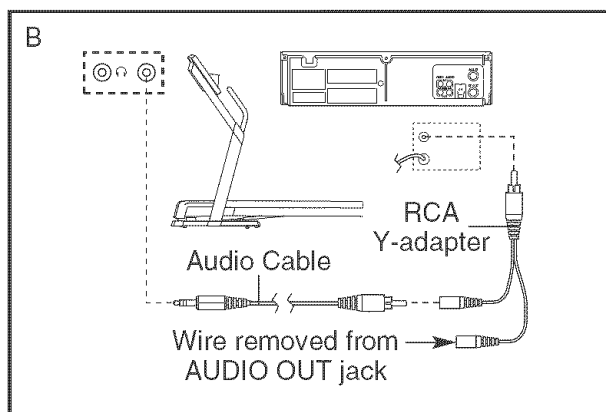

## HOW TO USE AN iFIT.COM MP3, CD, OR VIDEO PROGRAM

To use an iFIT.com MP3, CD, or video program, the treadmill must be connected to your MP3 player, CD player, or VCR. See **HOW TO CONNECT THE TREADMILL TO USE iFIT.COM PROGRAMS** on pages 17 to 19. **To download iFIT.com MP3 programs, go to [www.iFIT.com](http://www.iFIT.com). To purchase iFIT.com CDs or videocassettes, call toll-free 1-888-533-1333.**

Follow the steps below to use an iFIT.com MP3, CD, or video program.

- 1** Insert the key into the console.

See **HOW TO TURN ON THE POWER** on page 12.

- 2** Select the iFIT.com mode.

To select the iFIT.com mode, press the Program Select button repeatedly until the letters "iFIT" appear in the display.

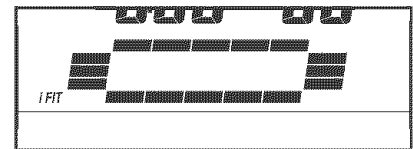

- 3** Press the Play button on your MP3 player, CD player, or VCR.

**Note:** If you are using an iFIT.com CD, insert the CD into your CD player; if you are using an iFIT.com videocassette, insert the videocassette into your VCR.

A moment after the Play button is pressed, your personal trainer will begin guiding you through your workout. Simply follow your personal trainer's instructions. **Note:** If the time is flashing in the display, press the Start button or the Speed + button on the console. The treadmill will not respond to an MP3, CD, or video program while the time is flashing in the display.

During the program, an electronic "chirping" sound will alert you when the speed and/or incline of the treadmill is about to change. **CAUTION: Always listen for the "chirp" and be prepared for speed and/or incline changes. In some instances, the speed and/or incline may change before your personal trainer describes the change.**

If the speed or incline settings are too high or too low, you can manually override the settings at any time by pressing the Speed or Incline buttons on the console. However, **when the next “chirp” is heard, the speed and/or incline will change to the next settings of the program.**

To stop the walking belt at any time, press the Stop button on the console. The time will begin to flash in the display. To restart the program, press the Start button or the Speed + button. After a moment, the walking belt will begin to move at 1.0 mph. **When the next “chirp” is heard, the speed and/or incline will change to the next settings of the program.**

When the program is completed, the walking belt will stop. Note: To use another MP3, CD, or video program, press the Stop button or remove the key and go to step 1 on page 19.

**Note: If the speed and/or incline of the treadmill does not change when a “chirp” is heard:**

- **Make sure that the letters “iFIT” appear in the display and that the time is not flashing in the display. If the time is flashing, press the Start button or the Speed + button on the console.**
- **Adjust the volume of your MP3 player, CD player, or VCR. If the volume is too high or too low, the console may not detect the program signals.**

- **Make sure that the audio cable is properly connected.**
- **If you are using a portable CD player and the CD skips, set the CD player on the floor or another flat surface instead of on the console.**
- **See the instructions at the bottom of page 27.**

**4 Follow your progress with the display.**

See step 5 on page 12.

**5 Measure your heart rate if desired.**

See step 6 on page 13.

**6 Turn on the fan if desired.**

See step 7 on page 13.

**7 When you are finished exercising, remove the key from the console.**

See step 7 on page 15.

**CAUTION: Always remove iFIT.com CDs and videocassettes from your CD player and VCR and disconnect your MP3 player when you are not using them.**

## HOW TO USE AN iFIT.COM PROGRAM DIRECTLY FROM OUR WEB SITE

Our Web site at [www.iFIT.com](http://www.iFIT.com) allows you to access basic programs, audio programs, and video programs directly from the internet. Additional options are soon to be available. See [www.iFIT.com](http://www.iFIT.com) for details.

To use programs from our Web site, the treadmill must be connected to your home computer. See HOW TO CONNECT YOUR COMPUTER on page 18. In addition, you must have an internet connection and an internet service provider. A list of specific system requirements is found on our Web site.

Follow the steps below to use a program from our Web site.

### 1 Insert the key into the console.

See HOW TO TURN ON THE POWER on page 12.

### 2 Select the iFIT.com mode.

To select the iFIT.com mode, press the Program Select button repeatedly until the letters "iFIT" appear in the display.

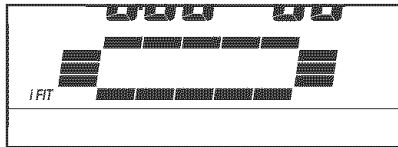

### 3 Go to your computer and start an internet connection.

### 4 Start your web browser, if necessary, and go to our Web site at [www.iFIT.com](http://www.iFIT.com).

### 5 Follow the desired links on our Web site to select a program.

Read and follow the on-line instructions for using a program.

### 6 Follow the on-line instructions to start the program.

When you start the program, an on-screen countdown will begin.

### 7 Return to the treadmill and stand on the foot rails. Find the clip attached to the key and slide the clip onto the waistband of your clothes.

When the on-screen countdown ends, the program will begin and the walking belt will begin to move. Hold the handrails, step onto the walking belt, and begin walking. During the program, an electronic "chirping" sound will alert you when the speed and/or incline of the treadmill is about to change. **CAUTION: Always listen for the "chirp" and be prepared for speed and/or incline changes.**

If the speed or incline settings are too high or too low, you can manually override the settings at any time by pressing the Speed or Incline buttons on the console. **However, when the next "chirp" is heard, the speed and/or incline will change to the next settings for the program.**

To stop the walking belt at any time, press the Stop button on the console. The time will begin to flash in the display. To restart the program, press the Start button or the Speed + button. After a moment, the walking belt will begin to move at 1.0 mph. **When the next "chirp" is heard, the speed and incline will change to the next settings of the program.**

When the program is completed, the walking belt will stop. Note: To use another program, press the Stop button and go to step 5.

**Note: If the speed and/or incline of the treadmill does not change when a "chirp" is heard, make sure that the letters "iFIT" appear in the display and that the time is not flashing in the display. In addition, make sure that the audio cable is properly connected.**

### 8 Follow your progress with the display.

See step 5 on page 12.

### 9 When you are finished exercising, remove the key from the console.

See step 7 on page 15.

## THE INFORMATION MODE/DEMO MODE

The console features an information mode that keeps track of the total number of hours that the treadmill has been operated and the total number of miles that the walking belt has moved. The information mode also allows you to select miles or kilometers as the unit of measurement and to turn on and turn off the demo mode.

To select the information mode, hold down the Stop button while inserting the key into the console. When the information mode is selected, the following information will be shown in the display:

The left side of the display will show the total number of miles (or kilometers) that the walking belt has moved and the total number of hours

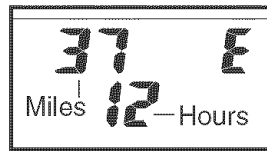

that the treadmill has been used. An “E” for English miles or an “M” for metric kilometers will appear in the right side of the display. Press the Speed + button to change the unit of measurement.

**IMPORTANT:** If a “d” appears in the right side of the display, the console is in the “demo” mode. This mode is intended to be used only when a treadmill is displayed in a store. When the console is in the demo mode, the power cord can be plugged in, the key can be removed from the console, and the indicators in the display will automatically appear in a preset sequence, although the buttons on the console will not operate. **If a “d” appears when the information mode is selected, press the Speed – button so “d” disappears.**

To exit the information mode, remove the key from the console.

# HOW TO FOLD AND MOVE THE TREADMILL

## HOW TO FOLD THE TREADMILL FOR STORAGE

Before folding the treadmill, adjust the incline to the lowest position. If this is not done, the treadmill may be permanently damaged. Next, unplug the power cord. **CAUTION:** You must be able to safely lift 45 pounds (20 kg) to raise, lower, or move the treadmill.

1. Hold the treadmill with your hands in the locations shown by the arrow at the right. **To decrease the possibility of injury, bend your legs and keep your back straight. As you raise the treadmill, make sure to lift with your legs rather than your back.** Raise the treadmill about halfway to the vertical position.
2. Move your right hand to the position shown and hold the treadmill firmly. Using your left hand, pull the latch knob to the left and hold it. Raise the treadmill until the frame is past the latch pin. Slowly release the latch knob. **Make sure that the frame is securely held by the latch pin.**

**To protect the floor or carpet from damage, place a mat under the treadmill. Keep the treadmill out of direct sunlight. Do not leave the treadmill in the storage position in temperatures above 85° Fahrenheit.**

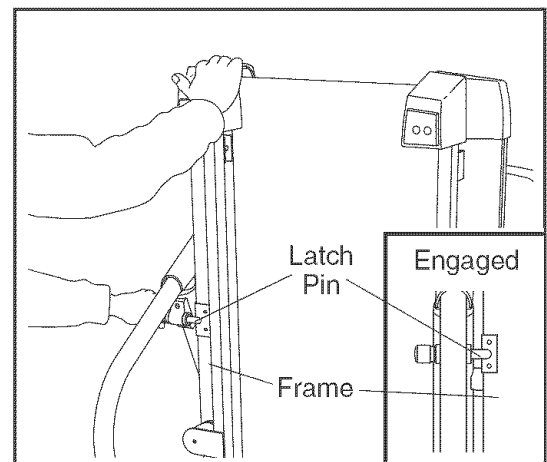
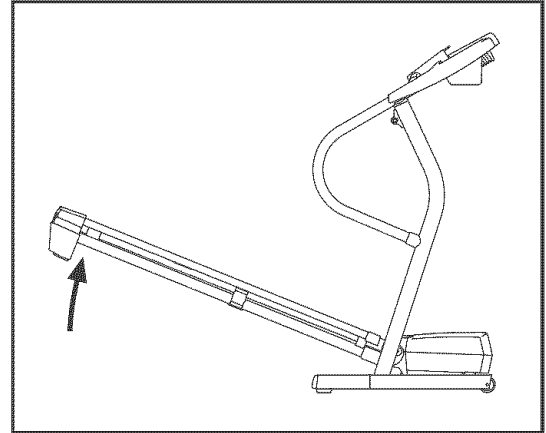

## HOW TO MOVE THE TREADMILL

Before moving the treadmill, convert the treadmill to the storage position as described above. **Make sure that the frame is securely held by the storage latch.**

1. Hold the upper ends of the handrails. Place one foot on a front wheel.
2. Tilt the treadmill back until it rolls freely on the front wheels. Carefully move the treadmill to the desired location. **To reduce the risk of injury, use extreme caution while moving the treadmill. Do not move the treadmill over an uneven surface.**
3. Place one foot on the base, and carefully lower the treadmill until it is resting in the storage position.

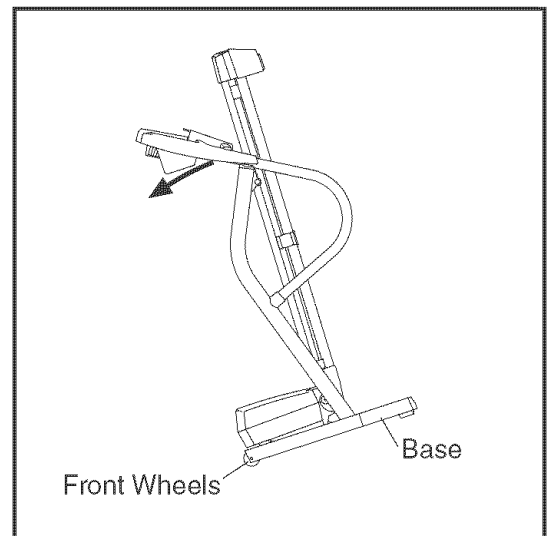

## HOW TO LOWER THE TREADMILL FOR USE

1. Hold the upper end of the treadmill with your right hand. Pull the latch knob to the left and hold it. Pivot the treadmill down until the catch is past the latch pin.

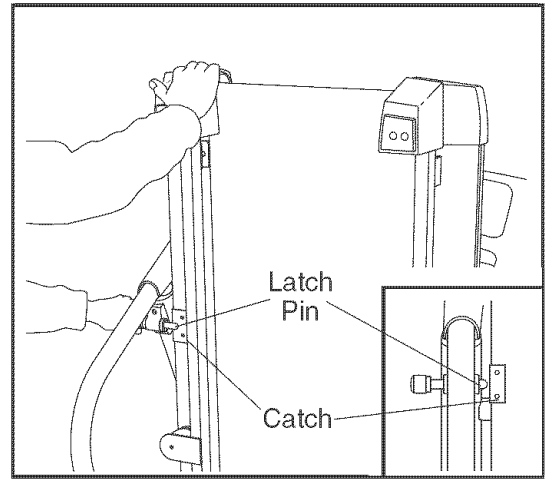

2. Hold the treadmill firmly with both hands, and lower the treadmill to the floor. **Do not drop the treadmill frame to the floor. To decrease the possibility of injury, bend your legs and keep your back straight.**

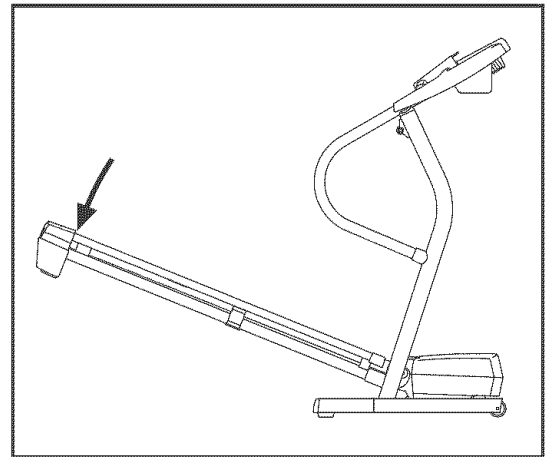



# TROUBLESHOOTING

Most treadmill problems can be solved by following the simple steps below. Find the symptom that applies, and follow the steps listed. If further assistance is needed, call toll-free 1-800-4-MY-HOME® (1-800-469-4663).

**PROBLEM: The power does not turn on**

**SOLUTION:** a. Make sure that the power cord is plugged into a surge suppressor, and that the surge suppressor is plugged into a properly grounded outlet (see page 10). Use only a single-outlet surge suppressor that meets all of the specifications described on page 10. Important: The treadmill is not compatible with GFCI-equipped outlets.

b. After the power cord has been plugged in, make sure that the key is fully inserted into the console.

c. Check the reset/off circuit breaker located on the treadmill frame near the power cord. If the switch protrudes as shown, the circuit breaker has tripped. To reset the circuit breaker, wait for five minutes and then press the switch back in.

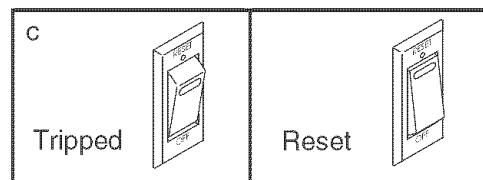

**PROBLEM: The power turns off during use**

**SOLUTION:** a. Check the circuit breaker located on the treadmill frame near the power cord (see the drawing above). If the circuit breaker has tripped, wait for five minutes and then press the switch back in.

b. Make sure that the power cord is plugged in. If the power cord is plugged in, unplug it, wait for five minutes, and then plug it back in.

c. Remove the key from the console. Reinsert the key fully into the console.

d. If the treadmill still will not run, please call toll-free 1-800-4-MY-HOME® (1-800-469-4663).

**PROBLEM: The displays of the console do not function properly**

**SOLUTION:** a. Remove the key from the console and **UNPLUG THE POWER CORD**. Remove the Screws (49) from the Hood (1), and carefully pivot the Hood off.

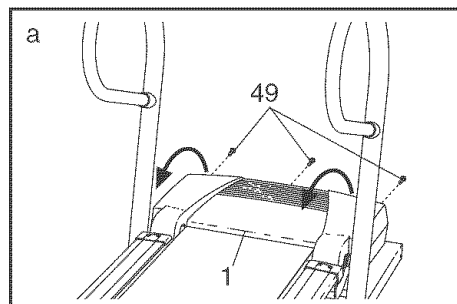

Locate the Reed Switch (10) and the Magnet (18) on the left side of the Pulley (17). Turn the Pulley until the Magnet is aligned with the Reed Switch. **Make sure that the gap between the Magnet and the Reed Switch is about 1/8"**. If necessary, loosen the Screw (58), move the Reed Switch slightly, and then retighten the Screw. Reattach the Hood, and run the treadmill for a few minutes to check for a correct speed reading.

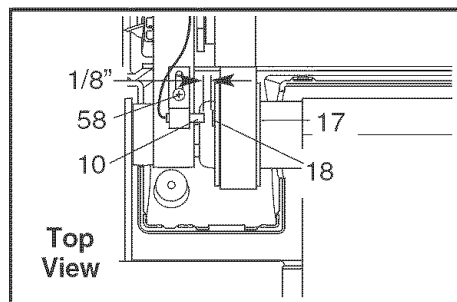

**PROBLEM: The walking belt slows when walked on**

**SOLUTION:** a. Use only a single-outlet surge suppressor that meets all of the specifications described on page 10.

b. If the walking belt is overtightened, treadmill performance may decrease and the walking belt may become damaged. Remove the key and **UNPLUG THE POWER CORD**. Using the allen wrench, turn both rear roller adjustment bolts counterclockwise, 1/4 of a turn. When the walking belt is properly tightened, you should be able to lift each side of the walking belt 2 to 3 inches off the walking platform. Be careful to keep the walking belt centered. Plug in the power cord, insert the key, and run the treadmill for a few minutes. Repeat until the walking belt is properly tightened.

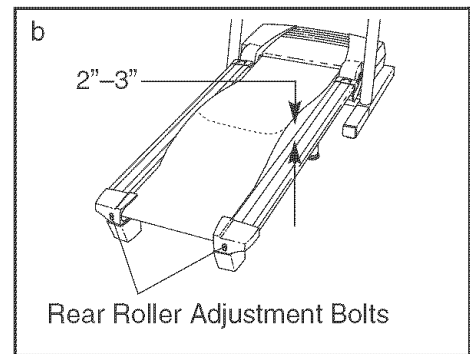

c. If the walking belt still slows when walked on, please call toll-free 1-800-4-MY-HOME® (1-800-469-4663).

**PROBLEM: The walking belt is off-center or slips when walked on**

**SOLUTION:** a. If the walking belt is off-center, first remove the key and **UNPLUG THE POWER CORD**. If the walking belt has shifted to the left, use the allen wrench to turn the left rear roller bolt clockwise 1/2 of a turn; if the walking belt has shifted to the right, turn the left bolt counterclockwise 1/2 of a turn. Be careful not to overtighten the walking belt. Plug in the power cord, insert the key, and run the treadmill for a few minutes. Repeat until the walking belt is centered.

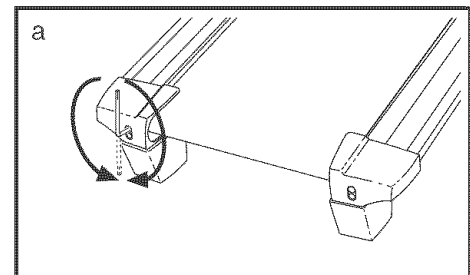

b. If the walking belt slips when walked on, first remove the key and **UNPLUG THE POWER CORD**. Using the allen wrench, turn both rear roller bolts clockwise, 1/4 of a turn. When the walking belt is correctly tightened, you should be able to lift each side of the walking belt 2 to 3 inches off the walking platform. Be careful to keep the walking belt centered. Plug in the power cord, insert the key, and carefully walk on the treadmill for a few minutes. Repeat until the walking belt is properly tightened.

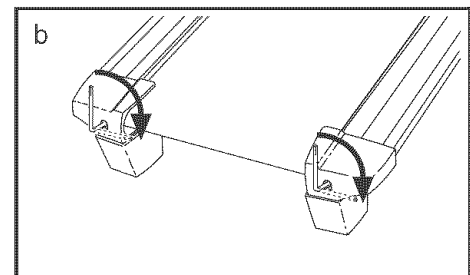

# CONDITIONING GUIDELINES

**⚠ WARNING:** Before beginning this or any exercise program, consult your physician. This is especially important for individuals over the age of 35 or individuals with pre-existing health problems.

The pulse sensor is not a medical device. Various factors, including your movement, may affect the accuracy of heart rate readings. The sensor is intended only as an exercise aid in determining heart rate trends in general.

The following guidelines will help you to plan your exercise program. For more detailed exercise information, obtain a reputable book or consult your physician.

## EXERCISE INTENSITY

Whether your goal is to burn fat or to strengthen your cardiovascular system, the key to achieving the desired results is to exercise with the proper intensity. The proper intensity level can be found by using your heart rate as a guide. The chart below shows recommended heart rates for fat burning and aerobic exercise.

AEROBIC	165	155	145	140	130	125	115
MAX FAT BURN	145	138	130	125	118	110	103
FAT BURN	125	120	115	110	105	95	90
Age	20	30	40	50	60	70	80

To find the proper heart rate for you, first find your age near the bottom of the chart (ages are rounded off to the nearest ten years). Next, find the three numbers above your age. The three numbers define your “training zone.” The lower two numbers are recommended heart rates for fat burning; the higher number is the recommended heart rate for aerobic exercise.

To measure your heart rate during exercise, use the pulse sensor.

## Fat Burning

To burn fat effectively, you must exercise at a relatively low intensity level for a sustained period of time. During the first few minutes of exercise, your body uses easily accessible *carbohydrate calories* for en-

ergy. Only after the first few minutes does your body begin to use stored *fat calories* for energy. If your goal is to burn fat, adjust the speed and incline of the treadmill until your heart rate is near the lowest number in your training zone.

For maximum fat burning, adjust the speed and incline of the treadmill until your heart rate is near the middle number in your training zone.

## Aerobic Exercise

If your goal is to strengthen your cardiovascular system, your exercise must be “aerobic.” Aerobic exercise is activity that requires large amounts of oxygen for prolonged periods of time. This increases the demand on the heart to pump blood to the muscles, and on the lungs to oxygenate the blood. For aerobic exercise, adjust the speed and incline of the treadmill until your heart rate is near the highest number in your training zone.

## WORKOUT GUIDELINES

Each workout should include the following three parts:

**A Warm-up**—Start each workout with 5 to 10 minutes of stretching and light exercise. A proper warm-up increases your body temperature, heart rate and circulation in preparation for exercise.

**Training Zone Exercise**—After warming up, increase the intensity of your exercise until your pulse is in your training zone for 20 to 60 minutes. (During the first few weeks of your exercise program, do not keep your pulse in your training zone for longer than 20 minutes.) Breathe regularly and deeply as you exercise—never hold your breath.

**A Cool-down**—Finish each workout with 5 to 10 minutes of stretching to cool down. This will increase the flexibility of your muscles and will help prevent post-exercise problems.

## EXERCISE FREQUENCY

To maintain or improve your condition, complete three workouts each week, with at least one day of rest between workouts. After a few months, you may complete up to five workouts each week if desired. The key to success is to make exercise a regular and enjoyable part of your everyday life.

# PART LIST—Model No. 831.295550

R0105C

Key No.	Qty.	Description	Key No.	Qty.	Description	Key No.	Qty.	Description
1	1	Hood	43	1	Console	86	1	Frame
2	27	3/4" Screw	44	1	Latch assembly	87	1	Walking Platform
3	1	Motor Belt	45	2	Front Isolator	88	1	Ground Wire
4	1	Idler Nut	46	1	Book Holder	89	2	Cable Tie Clamp
5	2	Idler Washer	47	1	Console Base	90	1	Outlet Plate
6	1	Idler Pulley	48	6	1/2" Screw	91	1	Sensor Clip
7	1	Idler Pulley Bolt	49	11	Hood Screw/ Endcap Screw	92	2	Rear Roller Adjustable Bolt
8	1	Drive Motor	50	1	Key/Clip	93	1	Right Rear Endcap
9	1	Idler Pivot Bolt	51	1	Incline Motor	94	1	Allen Wrench
10	1	Reed Switch	52	1	Incline Bracket	95	1	Right Rear Endcap Pad
11	1	Latch Warning Decal	53	1	Incline Motor Bolt, Lower	96	1	Walking Belt
12	2	Frame Spacer	54	3	Incline Pivot Bolt	97	1	Small Bolt
13	7	Frame Pivot Nut	55	4	Extension Screw	98	2	Handrail Bolt
14	2	Platform Nut	56	1	Motor Controller Wire	99	1	Filter Wire
15	4	Walking Platform Screw	57	4	Base Pad	100	1	Pulse Plate, Left
16	2	Foot Rail	58	9	3/4" Tek Screw	101	2	Star Washer
17	1	Front Roller/Pulley	59	1	Controller	102	3	Power Bracket Screw/ Plate Screw
18	1	Magnet	60	1	Lift Frame	103	2	Handrail Endcap
19	1	Idler Arm	61	2	Base Pad	104	1	Pulse Plate, Right
20	2	Motor Bolt	62	2	Warning Decal	105	1	Optic Disk
21	1	Right Foot Rail Endcap	63	2	Extension Leg	106	1	Small Nut
22	3	Belly Pan Clip	64	2	Wheel Bolt	107	1	Photo Switch
23	1	Front Roller Adjustment Bolt	65	2	Base Endcap	108	4	Wheel Spacer
24	1	Left Rear Endcap	66	2	Wheel	109	2	Isolator Cap (Top)
25	4	Ground Screw	67	2	U-Nut	110	2	Large Isolator
26	2	Walking Platform Screw, Rear	68	4	8" Cable Tie	111	2	Isolator Bolt
27	1	Fan Grill, Back	69	1	Upright	112	2	Foot Rail Cover
28	1	Idler Spring	70	1	Grommet	113	1	5/32" Allen Wrench
29	1	Latch Housing	71	1	Left Handrail	114	2	Isolator Cap (Bottom)
30	1	Catch	72	1	Right Handrail	115	1	Incline Sensor Wire
31	1	Left Rear Endcap Pad	73	2	Upright Cap	#	1	8" Black Wire, 2 Ring
32	2	Wheel Nut	74	1	Left Foot Rail Endcap	#	1	4" Black Wire, M/F
33	2	Static Decal	75	1	Silver Ground Screw	#	1	4" Blue Wire, 2F
34	1	Left Grip Plate	76	1	iFIT.com Cable	#	1	8" Green Wire, F/R
35	1	Small Star Washer	77	2	Wire Tie Screw	#	1	User's Manual
36	1	Right Grip Plate	78	1	Reset/Off Circuit Breaker			
37	2	3" Bolt	79	1	Power Cord			*Includes all parts shown in the box.
38	2	Washer	80	1	Power Cord Grommet			#These parts are not illustrated.
39	6	1" Tek Screw	81	1	Belly Pan			
40	1	Flat Nut	82	2	Belt Guide			<b>If a part is missing, call toll-free</b>
41	1	iFIT.com Wire	83	4	Belt Guide Screw			<b>1-888-533-1333.</b>
42	1	Upright Wire	84	1	Fan			
			85	1	Rear Roller			

# EXPLODED DRAWING—Model No. 831.295550

R0105C

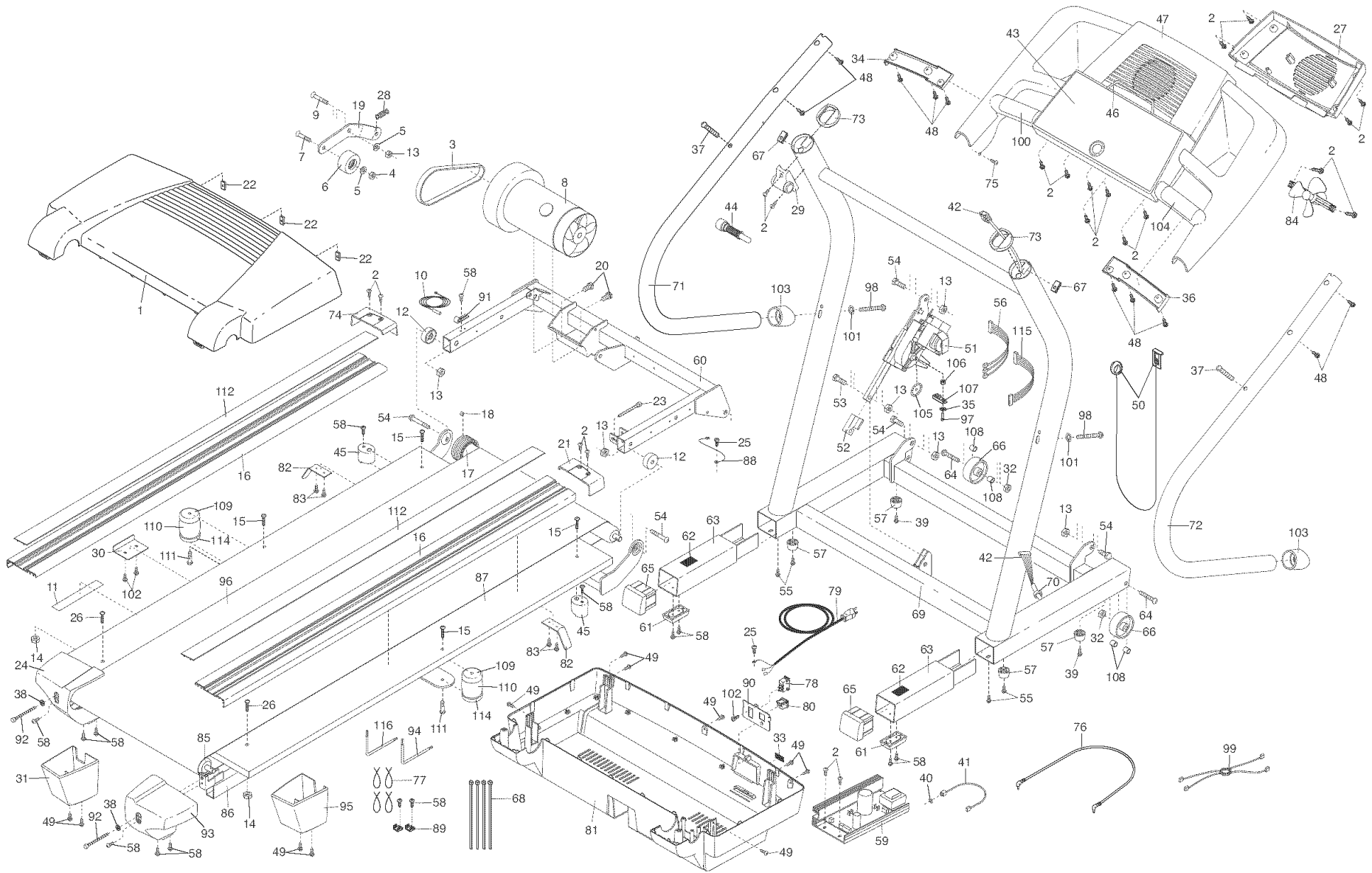

## Get it fixed, at your home or ours!

### Your Home

For repair – **in your home** – of **all** major brand appliances, lawn and garden equipment, or heating and cooling systems, **no matter who made it, no matter who sold it!**

For the replacement parts, accessories, and user's manuals that you need to do-it-yourself.

For Sears professional installation of home appliances and items like garage door openers and water heaters.

**1-800-4-MY-HOME®**

(1-800-469-4663)

[www.sears.com](http://www.sears.com)

Anytime, day or night

(U.S.A. and Canada)

[www.sears.ca](http://www.sears.ca)

---

### Our Home

For repair of carry-in products like vacuums, lawn equipment, and electronics, **call or go on-line for the location of your nearest Sears Parts and Repair Center.**

**1-800-488-1222** Anytime, day or night (U.S.A. only)

[www.sears.com](http://www.sears.com)

---

To purchase a protection agreement (U.S.A.) or maintenance agreement (Canada) on a product serviced by Sears:

**1-800-827-6655** (U.S.A.)

**1-800-361-6665** (Canada)

---

Para pedir servicio de reparación a domicilio, y para ordenar piezas:

**1-888-SU-HOGAR<sup>SM</sup>** (1-888-784-6427)

# SEARS

® Registered Trademark / ™ Trademark / ™ Service Mark of Sears, Roebuck and Co.  
® Marca Registrada / ™ Marca de Fábrica / ™ Marca de Servicio de Sears, Roebuck and Co.

## FULL 90 DAY WARRANTY

For 90 days from the date of purchase, if failure occurs due to defect in material or workmanship in this Sears Treadmill Exerciser, contact the nearest Sears Service Center throughout the United States and Sears will repair or replace the Treadmill Exerciser, free of charge. The drive motor is warranted for ten (10) years from the date of purchase.

This warranty does not apply when the Treadmill Exerciser is used commercially or for rental purposes.

This warranty gives you specific legal rights, and you may also have other rights which vary from state to state.

**Sears, Roebuck and Co., Dept. 817WA, Hoffman Estates, IL 60179**