

PRO-FORM[®]

CROSSXOVER

ELLIPTICAL TRAINER

Model No. 831.159950

Serial No. _____

Write the serial number in the space above for future reference.

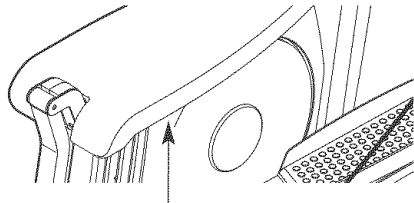

Serial Number Decal (Under Seat)

- Assembly
- Adjustments
- Troubleshooting
- Part List and Drawing

▲ CAUTION

Read all precautions and instructions in this manual before using this equipment. Save this manual for future reference.

ELLIPTICAL TRAINER EXERCISER

User's Manual

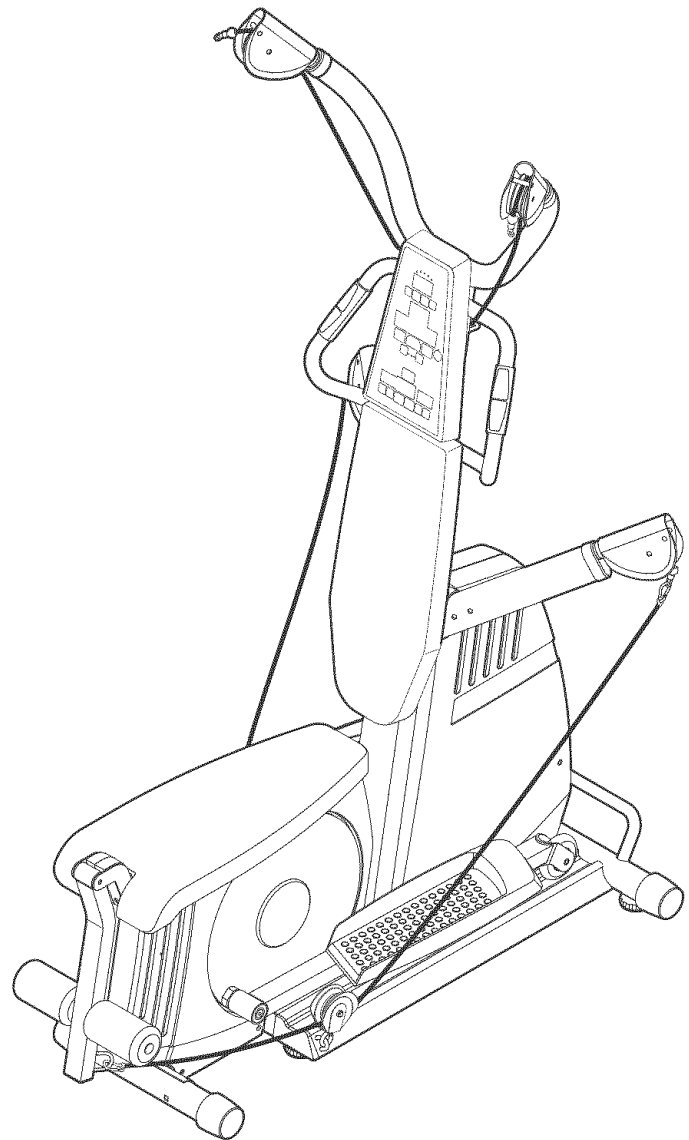

Sears, Roebuck and Co., Hoffman Estates, IL 60179

TABLE OF CONTENTS

WARNING DECAL PLACEMENT	2
IMPORTANT PRECAUTIONS	3
BEFORE YOU BEGIN	4
ASSEMBLY	5
ADJUSTMENTS	11
CONSOLE OPERATION	14
EXERCISE GUIDELINES	22
ORDERING REPLACEMENT PARTS	Back Cover
FULL 90-DAY WARRANTY	Back Cover

Note: A PART IDENTIFICATION CHART and a PART LIST/EXPLODED DRAWING are attached in the center of this manual. Remove the PART IDENTIFICATION CHART and PART LIST/EXPLODED DRAWING before beginning assembly.

WARNING DECAL PLACEMENT

The decal shown here has been placed on the elliptical trainer. If the decal is missing or illegible, please call toll-free 1-888-533-1333, Monday through Friday, 6 a.m. until 6 p.m. Mountain Time, and order a free replacement decal. Apply the decal in the location shown.

▲ WARNING

- To prevent damage, ONLY use the high pulley station when the seat is in the closest position to the upright.
- Maximum user weight is 250 lbs.

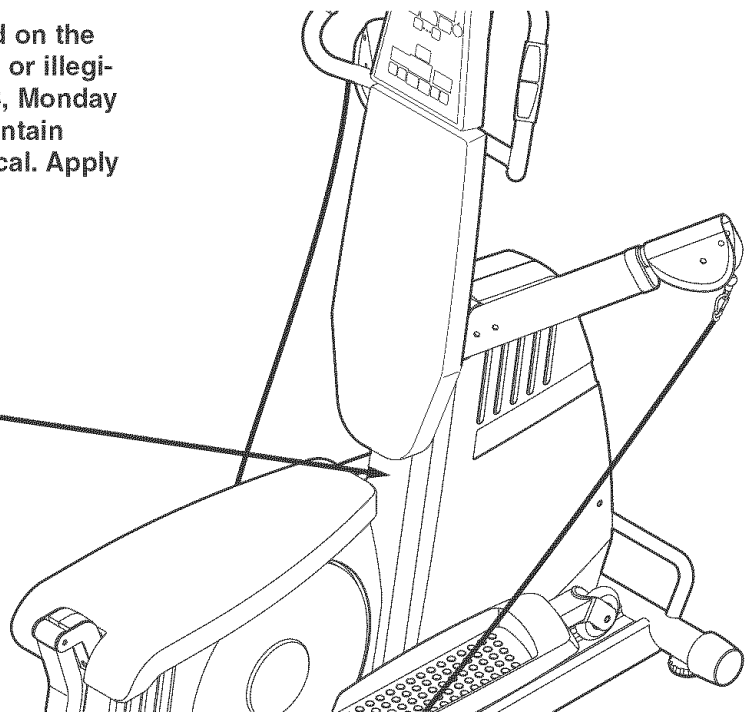

IMPORTANT PRECAUTIONS

▲ WARNING: To reduce the risk of serious injury, read the following important precautions before using the elliptical trainer.

1. Read all instructions in this manual before using the elliptical trainer. Use the elliptical trainer only as described in this manual.
2. It is the responsibility of the owner to ensure that all users of the elliptical trainer are adequately informed of all precautions.
3. The elliptical trainer is intended for home use only. Do not use the elliptical trainer in any commercial, rental, or institutional setting.
4. Use the elliptical trainer only on a level surface. Cover the floor beneath the elliptical trainer to protect the floor.
5. Keep the elliptical trainer indoors, away from moisture and dust. Do not put the elliptical trainer in a garage or covered patio, or near water.
6. Make sure that all parts are properly tightened each time the elliptical trainer is used. Replace any worn parts immediately.
7. Keep children under 12 and pets away from the elliptical trainer at all times.
8. Keep hands and feet away from moving parts.
9. Wear appropriate clothes when exercising; do not wear loose clothes that could become caught on the elliptical trainer. Always wear athletic shoes for foot protection while exercising.
10. The pulse sensor is not a medical device. Various factors, including the user's movement, may affect the accuracy of heart rate readings. The pulse sensor is intended only as an exercise aid in determining heart rate trends in general.
11. The elliptical trainer is designed to support a maximum user weight of 250 pounds.
12. The elliptical trainer is designed to be used with the included resistance. Do not use the elliptical trainer with dumbbells or any other type of weight to increase the resistance.
13. Make sure that the cables remain on the pulleys at all times. If the cables bind as you are exercising, stop immediately and make sure that the cables are on the pulleys. Replace all cables at least every two years.
14. Hold the handles when mounting, dismounting, or using the elliptical trainer's elliptical station.
15. Always keep your back straight when using the elliptical trainer; do not arch your back.
16. When you stop using the elliptical station, allow the pedals to slowly come to a stop. The elliptical trainer does not have a free-wheel; the pedals will continue to move until the flywheel stops.
17. Make sure that all electrical connections are complete before connecting the elliptical trainer to a power source.
18. Always unplug the power cord immediately after use and before cleaning the elliptical trainer.
19. Use the high pulley station only when the seat base is collapsed and secured next to the upright base.
20. If you feel pain or dizziness at any time while exercising, stop immediately and begin cooling down.

▲ WARNING: Before beginning this or any exercise program, consult your physician. This is especially important for persons over the age of 35 or persons with pre-existing health problems. Read all instructions before using. Sears assumes no responsibility for personal injury or property damage sustained by or through the use of this product.

BEFORE YOU BEGIN

Thank you for selecting the versatile PROFORM® CROSSOVER ELLIPTICAL TRAINER. The elliptical trainer offers a selection of weight stations designed to develop every major muscle group of the body. Whether your goal is to tone your body, build dramatic muscle size and strength, or improve your cardiovascular system, the elliptical trainer will help you to achieve the specific results you want.

For your benefit, read this manual carefully before using the elliptical trainer. If you have questions

after reading this manual, call 1-800-4-MY-HOME® (1-800-469-4663). To help us assist you, please note the product model number and serial number before calling. The model number is 831.159950. The serial number can be found on a decal attached to the elliptical trainer (see the front cover of this manual).

Before reading further, please review the drawing below and familiarize yourself with the parts that are labeled.

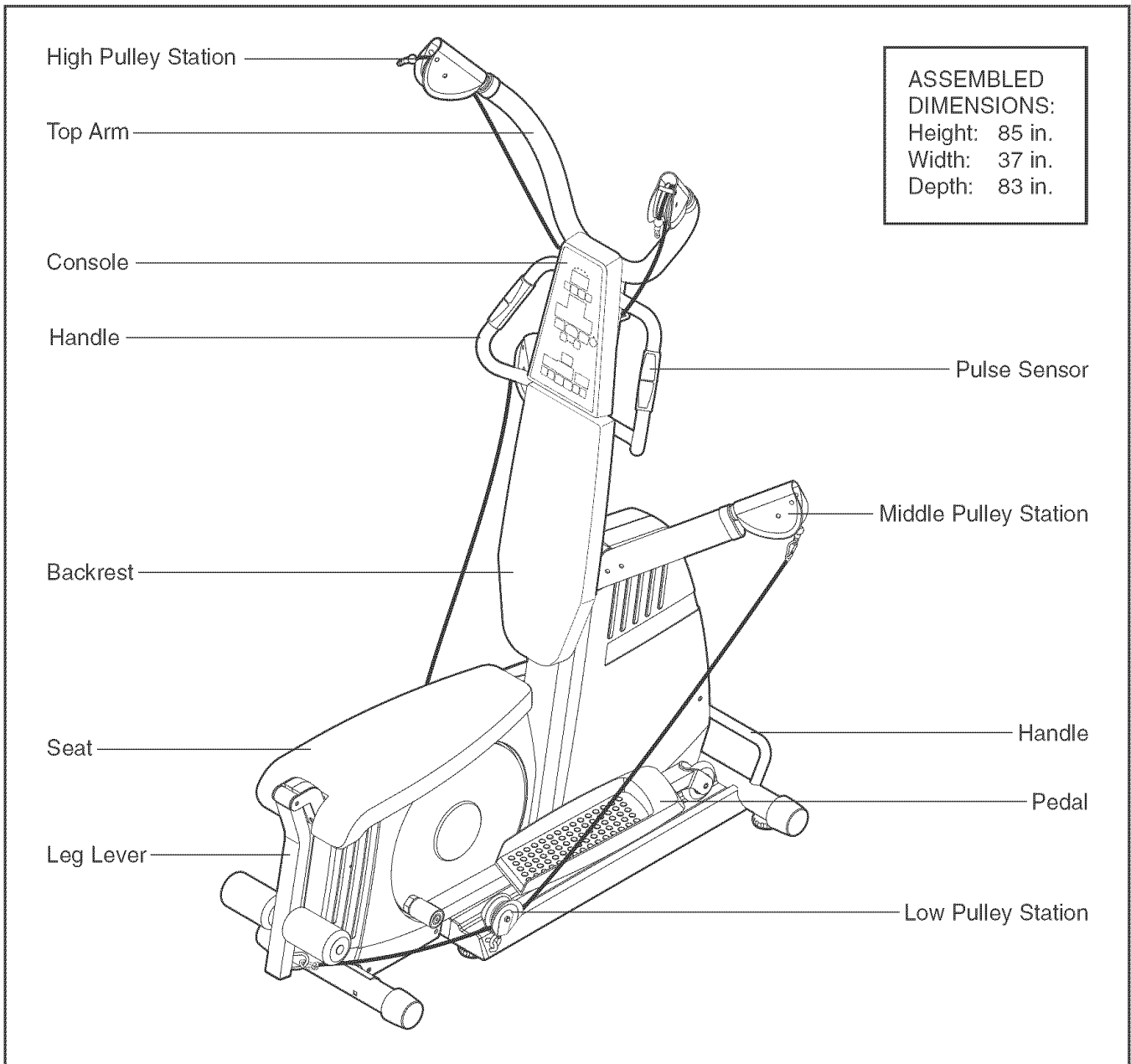

ASSEMBLY

Make Things Easier for Yourself



Everything in this manual is designed to ensure that the elliptical trainer can be assembled successfully by anyone. However, it is important to realize that the versatile elliptical trainer has many parts and that the assembly process will take time. Most people find that by setting aside plenty of time, assembly will go smoothly.

Before beginning assembly, carefully read the following information and instructions:

- Assembly requires two persons.
- Place all parts in a cleared area and remove the packing materials. Do not dispose of the packing materials until assembly is completed.
- Tighten all parts as you assemble them, unless instructed to do otherwise.

- As you assemble the elliptical trainer, make sure all parts are oriented as shown in the drawings.
- For help identifying small parts, use the PART IDENTIFICATION CHART.

The following tools (not included) are required for assembly:

- Two adjustable wrenches 
- One rubber mallet 
- One Phillips screwdriver 
- Lubricant, such as grease or petroleum jelly, and soapy water.

Assembly will be more convenient if you have a socket set, a set of open-end or closed-end wrenches, or a set of ratchet wrenches.

1. Remove the sheath covering the Rope (162).

Attach the Right Arm (12) to the Upright Base (1) with an M10 x 25mm Button Screw (87), an M10 x 54mm Button Bolt (90), an M10 Split Washer (114), three M10 Large Black Washers (186), and an M10 Nylon Locknut (81).

Attach the Left Arm (13 [not shown]) in the same manner.

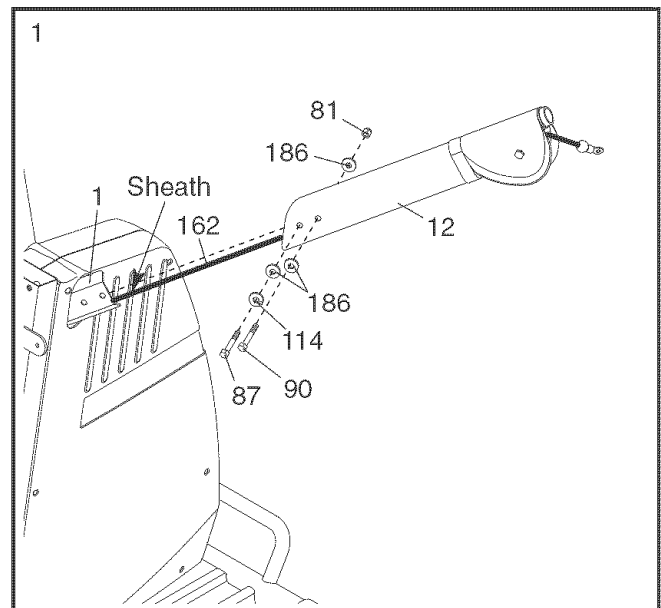

2. Attach the Seat Stabilizer (9) to the Seat Base (2) with two M10 x 78mm Carriage Bolts (149) and two M10 Nylon Locknuts (81).

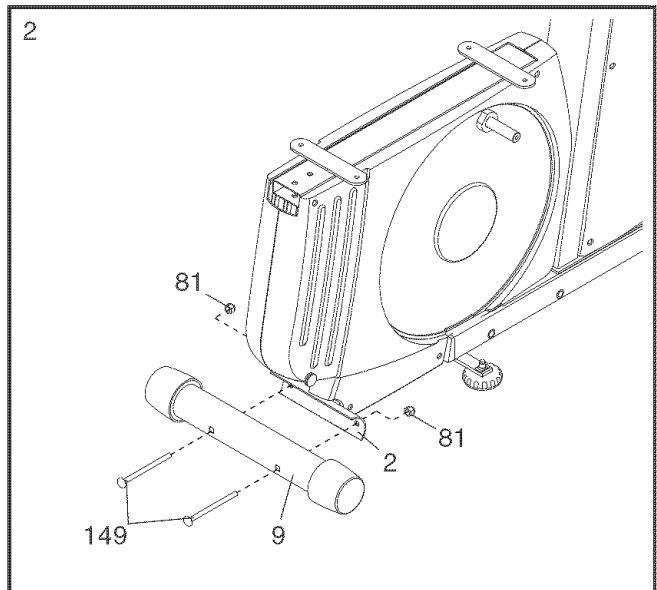

3. Attach the Upright Stabilizer (10) to the Upright Base (1) with two M10 x 78mm Button Screws (101) and two M10 Split Washers (114).

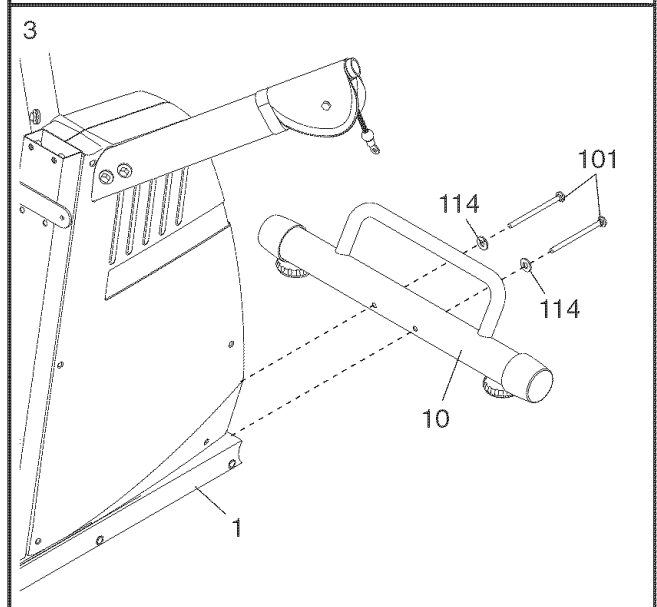

4. Identify the Right Rail (6). Carefully tip the Upright Base (1) and the Seat Base (2) onto the left side. Attach the Right Rail to the Upright Base with four M10 x 25mm Screws (86) and four M10 Large Zinc Washers (82).

Turn the Base Knob (44 [not shown]) out and attach the Left Rail (5 [not shown]) in the same manner.

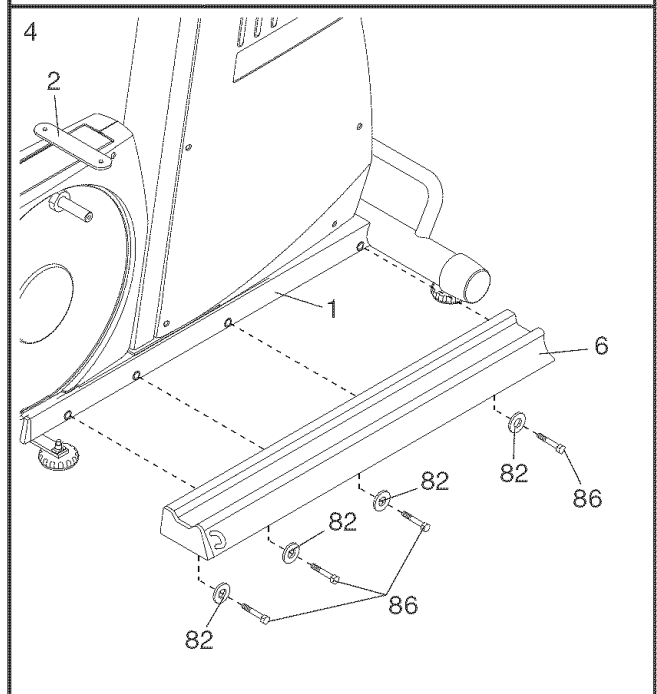

5. Insert the connector of the Upper Wire Harness (188) into the socket of the Middle Wire Harness (37). Next, connect the two Wire Harnesses (159) together in the same manner. **Note: The Upper Wire Harness connector is wider than the Wire Harness connectors.**

The connectors should slide easily into the sockets and snap into place. If a connector does not slide easily and snap into place, turn it over and then insert it. **IF THE CONNECTOR IS NOT INSERTED PROPERLY, THE CONSOLE MAY BE DAMAGED WHEN THE POWER IS TURNED ON.**

Pull the Upper Wire Harness (188) and the Wire Harness (159) in the indicated location to remove slack. Slide the Upright (3) into the Upright Base (1). **Be careful not to pinch the Wire Harnesses.** Attach the Upright to the Upright Base with four M10 x 25mm Patch Screws (135).

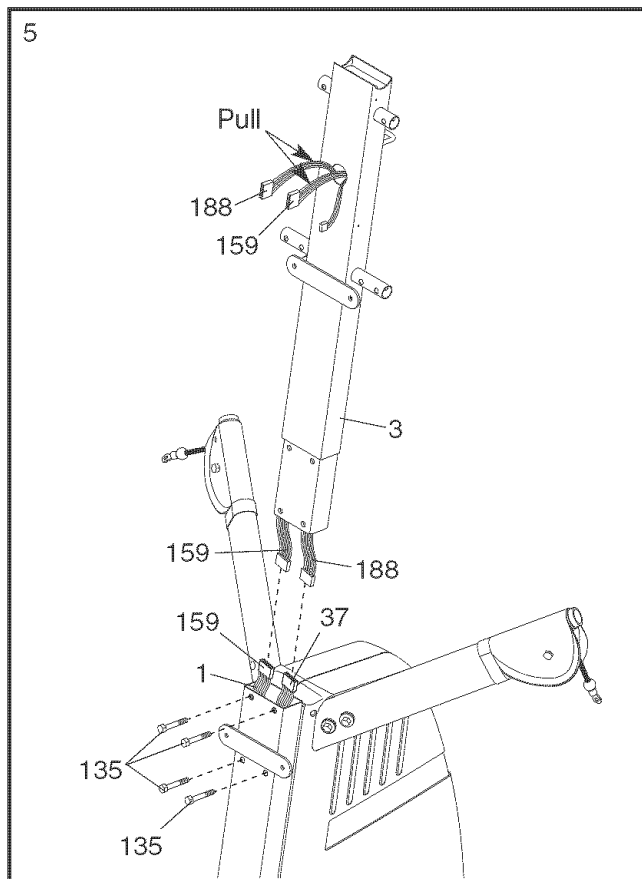

6. Hold the Right Handle (16) near the Upright (3). Connect the Pulse Sensor Wire (54) to the Sensor Wire Harness (187). Push the excess wire into the Upright.

The connector should slide easily into the socket and snap into place. If the connector does not slide easily and snap into place, turn it over and then insert it. **IF THE CONNECTOR IS NOT INSERTED PROPERLY, THE CONSOLE MAY BE DAMAGED WHEN THE POWER IS TURNED ON.**

Attach the Right Handle (16) to the Upright (3) with three M8 x 36mm Button Bolts (103) and three M8 Nylon Locknuts (102). **Make sure that the Locknuts sit inside of the hexagonal holes in the Right Handle.** Be careful not to pinch the wires with the Bolts.

Note: Make sure that the Long Handgrip (184) is pushed up against the Pulse Sensor (54).

Repeat this step with the Left Handle (17).

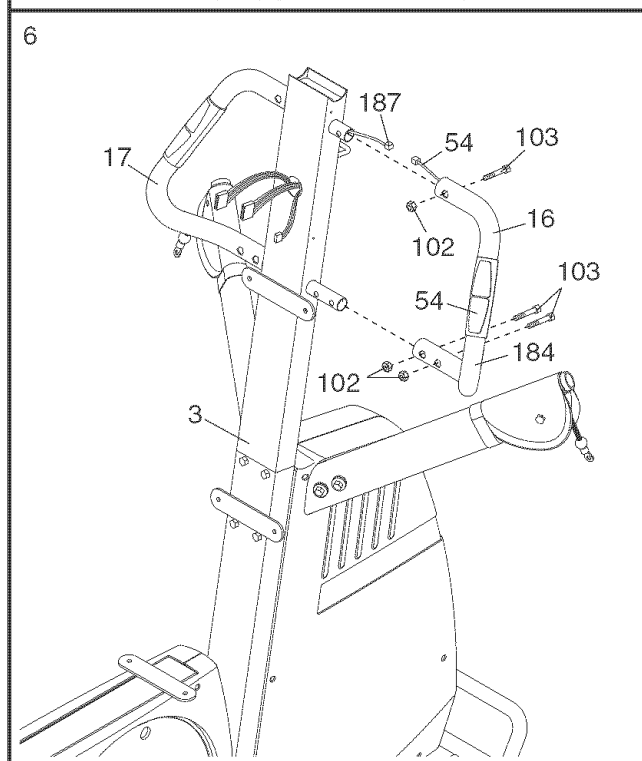

7. Attach the Backrest (22) to the Upright (3) and the Upright Base (1) with four M6 x 16mm Screws (130).

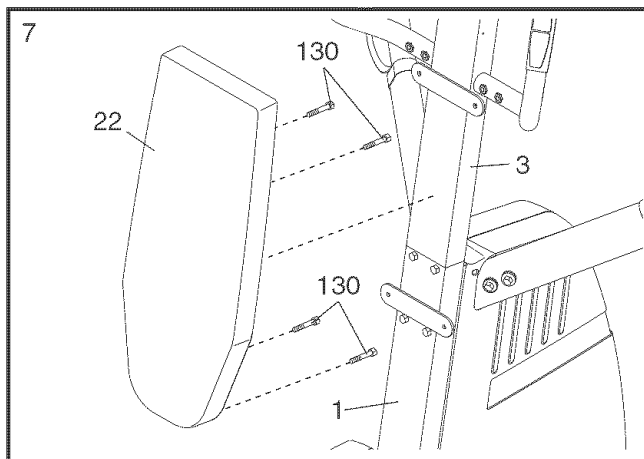

8. Connect the Sensor Wire Harness (187), the Wire Harness (159), and the Upper Wire Harness (188) to the Console (71). **Push the excess wire into the Upright (3).**

The connector should slide easily into the socket and snap into place. If a connector does not slide easily and snap into place, turn it over and then insert it. **IF THE CONNECTOR IS NOT INSERTED PROPERLY, THE CONSOLE MAY BE DAMAGED WHEN THE POWER IS TURNED ON.**

Attach the Console (71) to the Upright (3) with four M4 x 16mm Screws (85). **Make sure that the wires do not get pinched.**

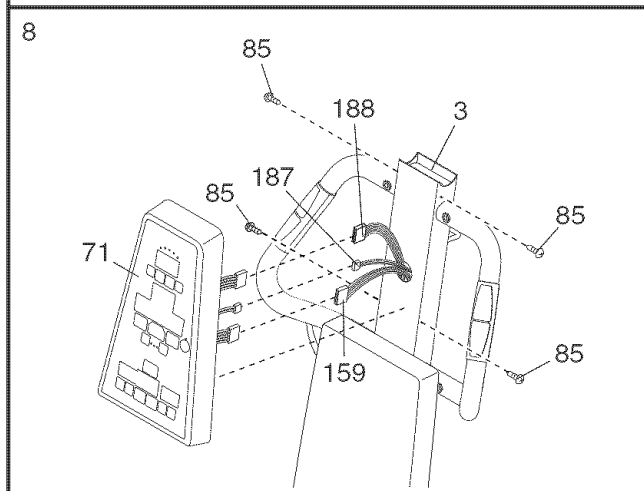

9. Attach the two Swivel Arms (58) to the Top Arm (11) with two M4 x 5mm Screws (131).

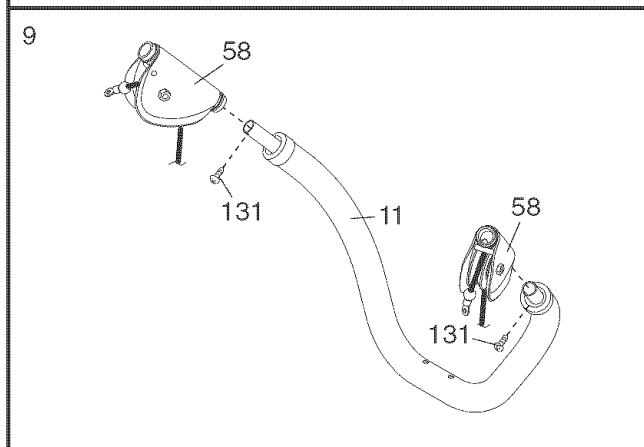

10. Attach the Top Arm (11) to the Upright (3) with two M10 x 75mm Patch Screws (99).

Route the Short Cables (163) through the bracket on the back of the Upright (3).

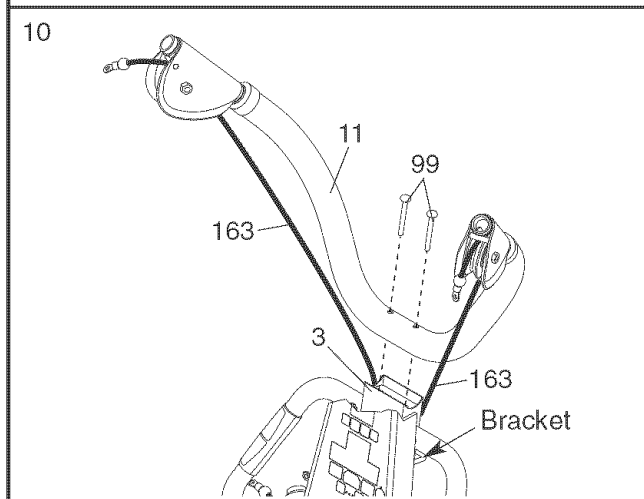

11. Attach the Leg Lever Bracket (14) to the Seat Base (2) with two M8 x 40mm Button Screws (142) and two M8 Split Washers (140).

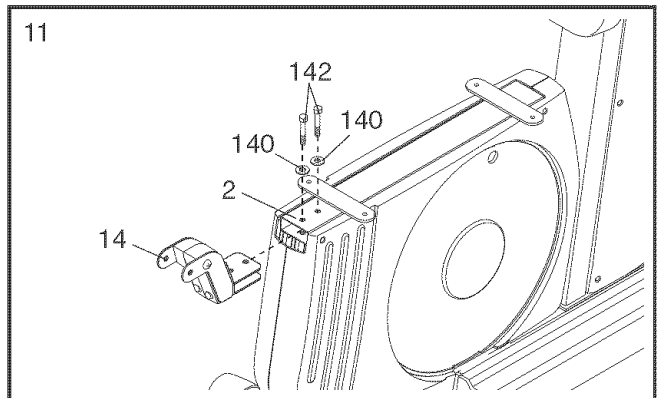

12. Grease an M10 x 75mm Button Bolt (129). Attach the Leg Lever (4) to the Leg Lever Bracket (14) with the Bolt and an M10 Nylon Locknut (81). **Do not overtighten the Locknut; the Leg Lever must be able to pivot easily.**

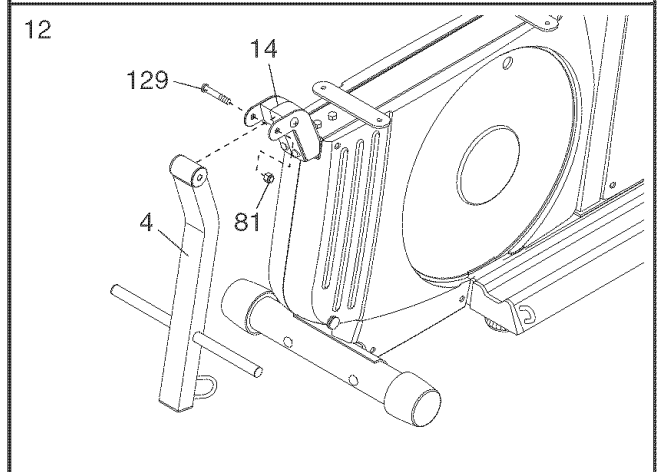

13. Attach the Right Pedal (28) to the Right Pedal Leg (8) with two M8 x 51mm Button Screws (98), two M8 Split Washers (140), and two M8 Washers (139).

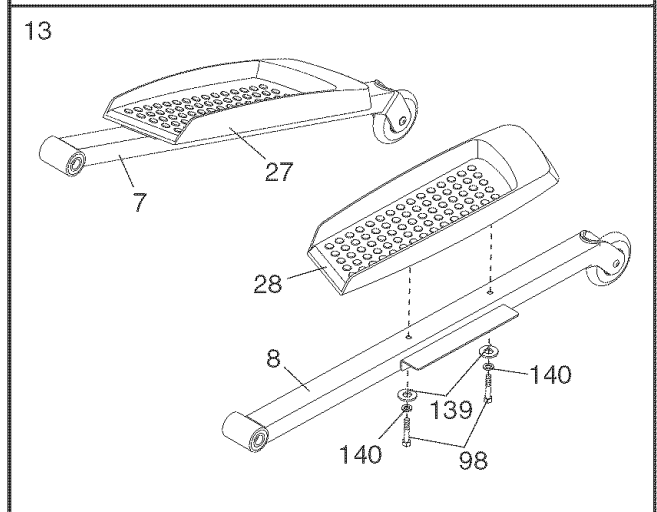

Repeat this step with the Left Pedal (27) and the Left Pedal Leg (7).

14. Slide a Plastic Spacer (180) onto the right Crank Shaft (68). Orient the Right Pedal Leg (8) as shown. Attach the Right Pedal Leg to the Crank Shaft with an M8 x 19mm Button Screw (94) and an M8 Large Zinc Washer (74).

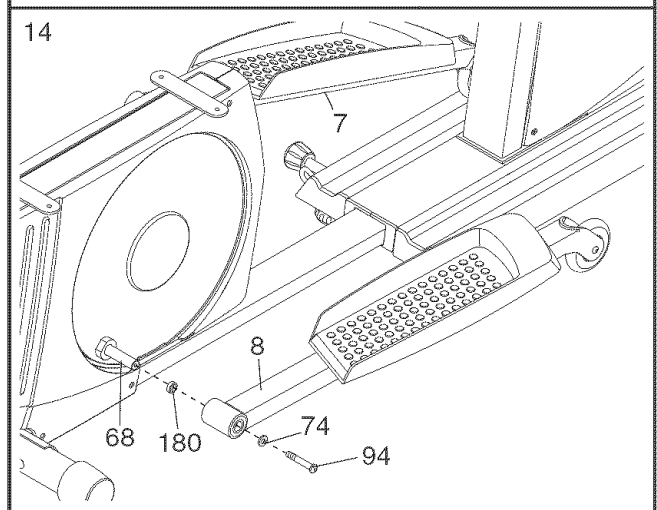

Repeat this step with the Left Pedal Leg (7).

15. Attach the Seat (23) to the Seat Base (2) with four M6 x 16mm Screws (130).

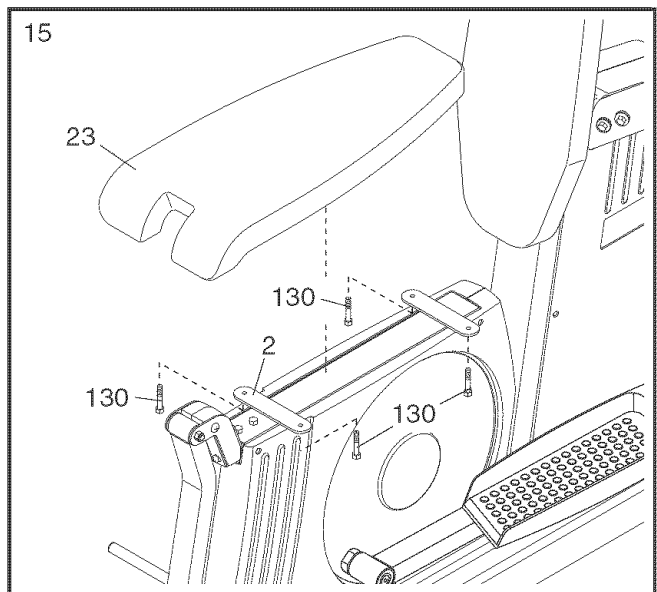

16. Slide the two Foam Pads (64) onto the Leg Lever (4).

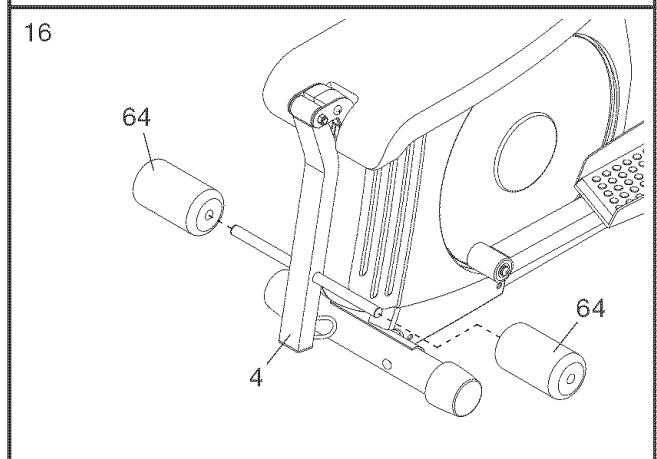

17. Adjust the Feet (48) under the Upright Stabilizer (10) to steady the elliptical trainer.

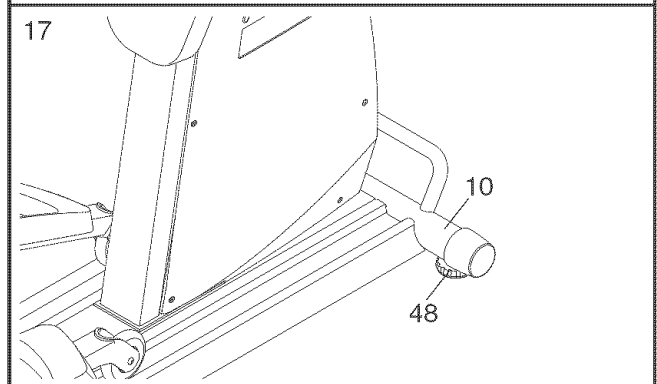

18. Make sure that all parts have been properly tightened. The use of the remaining parts will be explained in ADJUSTMENTS, beginning on the following page.

ADJUSTMENTS

This section explains how to adjust the elliptical trainer. See the EXERCISE GUIDELINES on page 22 for important information about how to get the most benefit from your exercise program. Also, refer to the accompanying exercise guide to see the correct form for each exercise.

Make sure that all parts are properly tightened each time the elliptical trainer is used. Replace any worn parts immediately. The elliptical trainer can be cleaned with a damp cloth and a mild, non-abrasive detergent. Do not use solvents.

ATTACHING THE SHORT CABLES

To use a high pulley station, attach the indicated end of a Short Cable (163), the end without the ball, to the Rope (162) with a Cable Clip (157).

When not using the high pulley stations, store the lower ends of the Short Cables (163) in the indicated bracket on the back of the Upright (3 [not shown]).

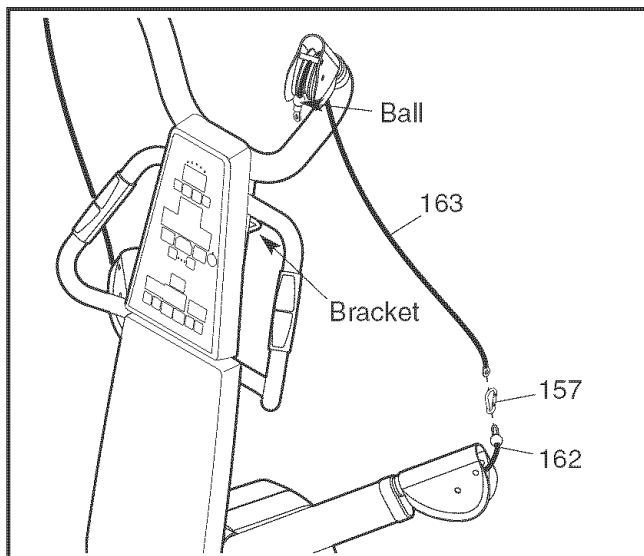

ATTACHING THE LOW PULLEY STATION

To use the low pulley station, attach the Long Cable (164) to the Rope (162) with a Cable Clip (157). Slide the hook on the Pulley Housing (105) onto the hook on the Left Rail (6). Attach the Long Cable to the appropriate attachment (see ATTACHING THE HAND STRAPS below, or ATTACHING THE LEG LEVER on page 12).

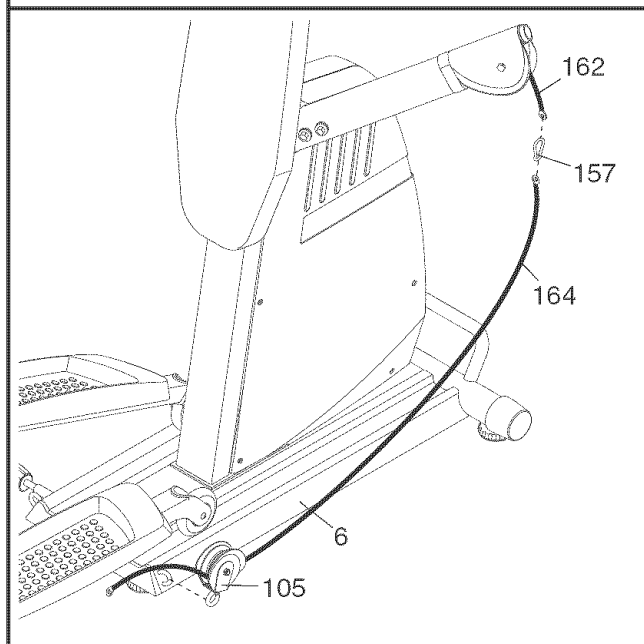

ATTACHING THE HAND STRAPS

To use a Hand Strap (160), connect it to a Short Cable (163) with a Cable Clip (157). For some exercises, an Extension Strap (175) should be attached between the Short Cable and the Hand Strap with two Cable Clips.

The Hand Straps (160) or the Ankle Strap (not shown) can be attached at any pulley stations in the same manner.

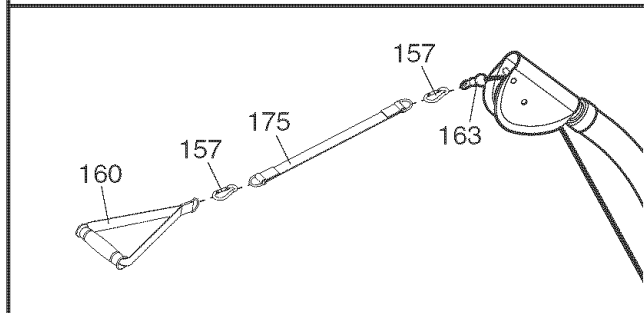

ATTACHING THE LEG LEVER

To use the Leg Lever (4), first attach the low pulley station (see ATTACHING THE LOW PULLEY STATION on page 11). Then, attach the Long Cable (164) to the Leg Lever (4) with a Cable Clip (157). **Always attach both Long Cables to the Leg Lever before using the Leg Lever. Note: The elliptical trainer must be in the collapsed position while the leg lever is used.**

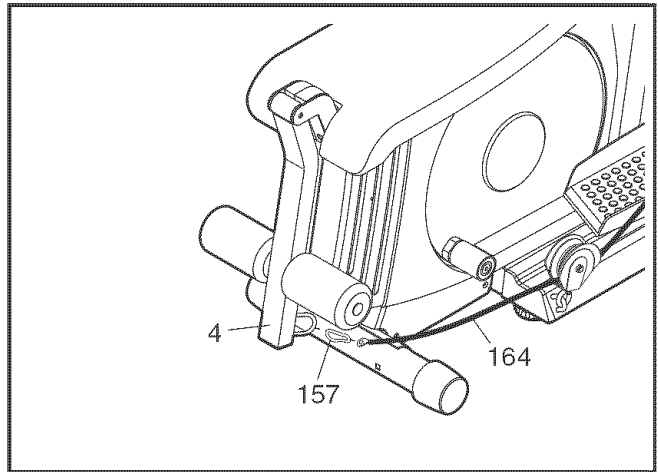

EXTENDING THE SEAT BASE

To use the Pedal Legs (7, 8), turn the Base Knob (44) to loosen it. Extend the elliptical trainer by pulling the Seat Base (2) away from the Upright Base (1) until it stops. Retighten the Base Knob into the Seat Base. Collapse the elliptical trainer in the same manner. **Always make sure the Base Knob is fully tightened before using the elliptical trainer.**

If it is difficult to extend the elliptical trainer, see ADJUSTING THE FEET on page 13.

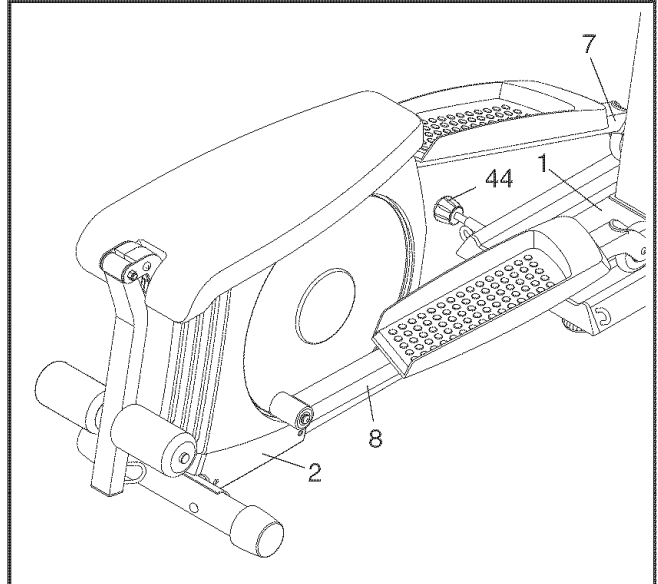

TIGHTENING THE ROPE

The type of rope used on the resistance system can stretch slightly when it is first used. If there is slack in the rope before resistance is felt, the rope should be tightened.

To tighten the Rope (162), first set the elliptical trainer resistance level to 100 pounds. Locate the end of the Rope with the Clamps (193, 194) and pull it out until the Rope is tight. Then, measure the distance between the Rope Cover (191) and the Swivel Arm (58).

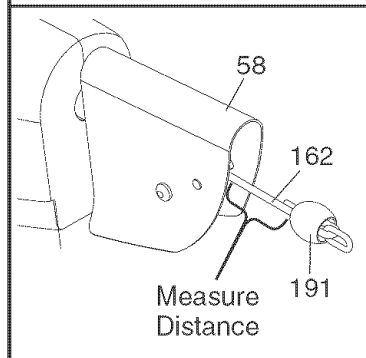

Set the elliptical trainer resistance to the lowest level. Have a second person pull the Rope (162) out and hold it while the Rope is adjusted. Push the Rope Cover (191) down the Rope and loosen the two M5 x 21mm Flat Head Screws (195). Pull the Rope through the Link (192) and the Rope Clamps (193, 194) to shorten the Rope by the measured amount. Then, retighten the two Screws and cover the Rope Clamps with the Rope Cover.

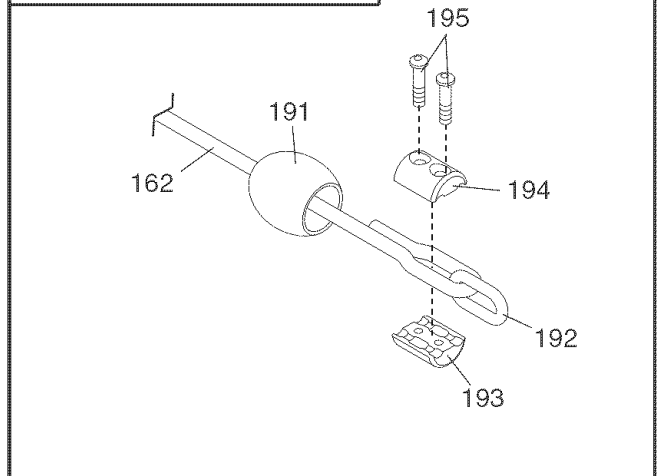

WARNING: Always make sure the two M5 x 21mm Flat Head Screws (195) are fully tightened before the elliptical trainer is used.

MOVING THE ELLIPTICAL TRAINER

To move the elliptical trainer, first unplug the Transformer (not shown) from the 120-volt outlet and secure the elliptical trainer in the collapsed position (see EXTENDING THE SEAT BASE on page 12). Then, using the handle on the Upright Stabilizer (10), tilt the elliptical trainer onto the Stabilizer Wheels (47). Finally, move the elliptical trainer to the new location.

⚠ WARNING: The elliptical trainer is heavy; lift with your knees to prevent injury to your back. Moving the elliptical trainer may require two persons.

⚠ CAUTION: When lifting the elliptical trainer, do not allow the upper swivel arms to touch the ceiling.

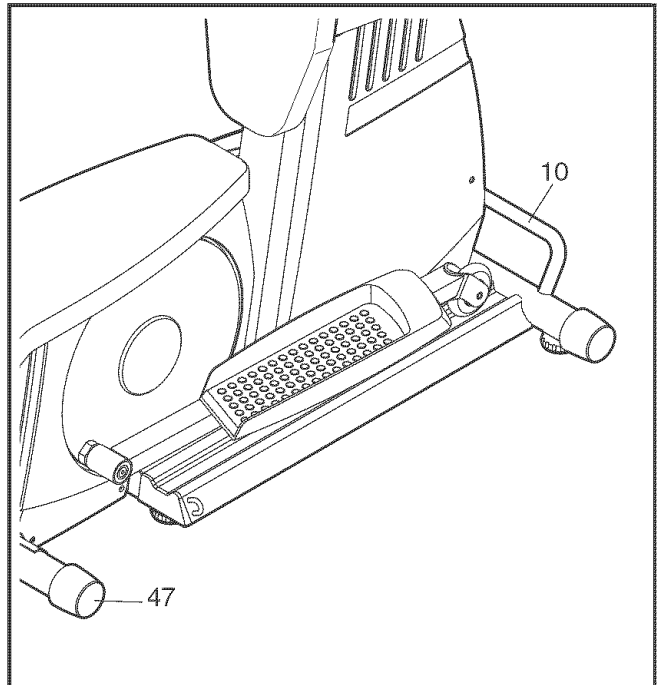

ADJUSTING THE FEET

If extending the elliptical trainer is difficult, adjust the Feet (48) so that the Seat Base (2) is parallel to the Upright Base (1). Adjust the Feet (A) all of the way into the Upright Base. Adjust the Feet (B) so that the Upright Stabilizer (10) is raised slightly.

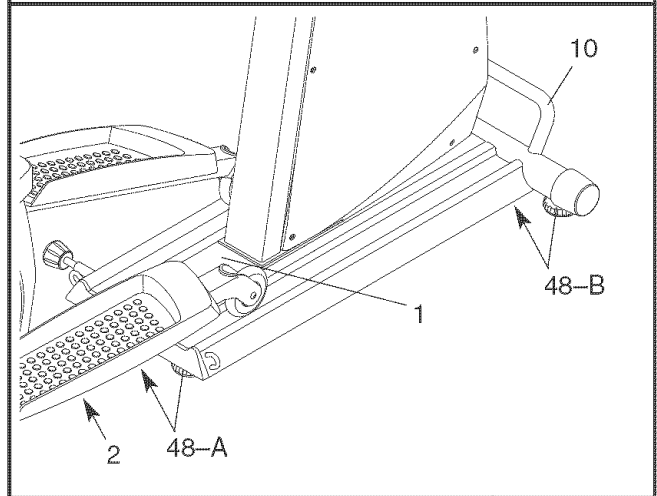

EXERCISING ON THE ELLIPTICAL STATION

To mount the elliptical station, firmly hold the Handles (16, 17) and carefully step onto the Pedal (27 or 28) that is in the lowest position. Next, step onto the other Pedal. Push the Pedals until they begin to move with a continuous motion. **Note: The Belt Pulley Covers (29) can turn in either direction. It is recommended that you turn the Belt Pulley Covers in the direction shown by the arrow below; however, for variety, you may turn the Belt Pulley Covers in the opposite direction.**

To dismount the elliptical station, allow the Pedals (27 or 28) to come to a complete stop. **Note: The elliptical trainer does not have a free wheel; the Pedals will continue to move until the flywheel stops.** When the pedals are stationary, step off the highest Pedal first. Then, step off the lowest Pedal.

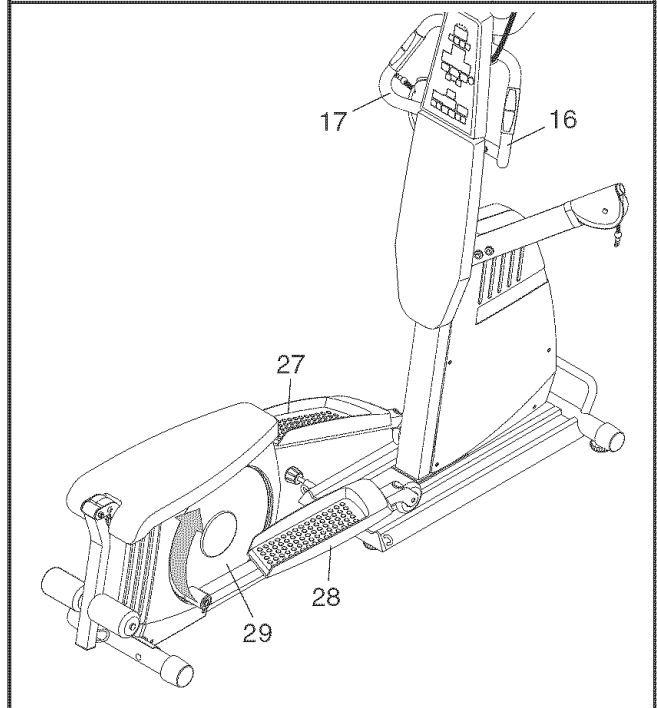

CONSOLE OPERATION

FEATURES OF THE CONSOLE

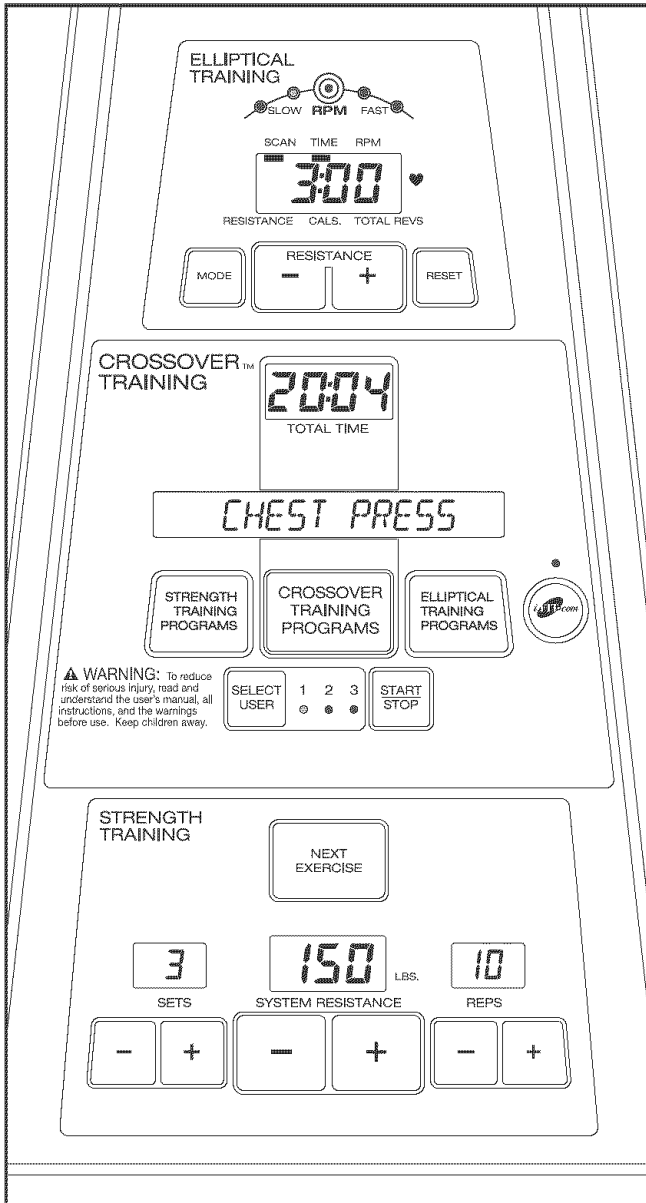

The heart of the elliptical trainer is the digital resistance training console, offering an impressive array of features designed to make your workouts more effective. When the manual mode of the console is selected, you can change the resistance of the elliptical trainer with the touch of a button. As you exercise, the console will display instant exercise feedback. You can even monitor your heart rate using the integrated pulse sensor.

The console also features six elliptical training programs and six strength training programs. Each program will guide you through an effective cardiovascular, weight loss, strength, or toning workout.

Ten crossover training programs are also offered. Each crossover training program combines elliptical exercise with strength training exercises to give you a combined cardiovascular and strength workout.

The console also features iFIT.com interactive technology. Having iFIT.com technology is like having a personal trainer in your home. Using a stereo audio cable (available at electronics stores), you can connect the elliptical trainer to your home stereo, portable stereo, computer, or VCR and play special iFIT.com CD and video programs (iFIT.com CDs and videocassettes are available separately). iFIT.com CD and video programs automatically control the resistance of the elliptical trainer and prompt you to vary your pace as a personal trainer coaches you through every step of your elliptical workout. High-energy music provides added motivation. **To purchase iFIT.com CDs and videocassettes, call toll-free 1-888-533-1333.**

With the elliptical trainer connected to your computer, you can also go to our Web site at www.iFIT.com and access programs directly from the internet. **Explore www.iFIT.com for more information.**

PLUGGING IN THE ELLIPTICAL TRAINER

Plug the indicated end of the transformer into the jack in the left mech cover. Plug the other end of the transformer into a 120-volt outlet. All indicators and displays on the console will flash once; the console will then be ready for use. The motor may be heard while the elliptical trainer calibrates itself. **Important: Always plug in the transformer when using the elliptical trainer.** Note: When the power is on, the words MANUAL MODE will appear in the CROSSOVER TRAINING display. If the buttons are not pressed, the cables are not pulled, and the pedals are not moved for ten minutes, the console will go to sleep. Press any button to resume exercising.

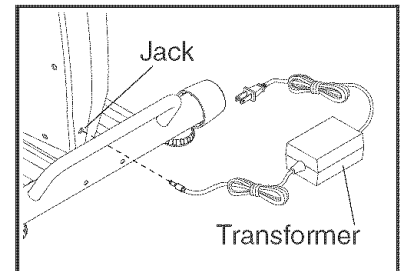

The motor may be heard while the elliptical trainer calibrates itself. **Important: Always plug in the transformer when using the elliptical trainer.** Note: When the power is on, the words MANUAL MODE will appear in the CROSSOVER TRAINING display. If the buttons are not pressed, the cables are not pulled, and the pedals are not moved for ten minutes, the console will go to sleep. Press any button to resume exercising.

To use the elliptical training features, see ELLIPTICAL TRAINING on pages 15 and 16. To use the strength training features, see STRENGTH TRAINING on pages 16 and 17. To use a crossover training program, see CROSSOVER TRAINING on page 18.

ELLIPTICAL TRAINING

MANUAL OPERATION

1. Plug In the Transformer.

See PLUGGING IN THE ELLIPTICAL TRAINER on page 14. **Important: Always plug in the transformer when using the elliptical trainer.**

2. Extend the Seat Base.

See EXTENDING THE SEAT BASE on page 12.

3. Select the Manual Mode.

When the transformer is plugged in, the manual mode will be selected. If you have already selected a program, press the ELLIPTICAL TRAINING PROGRAMS button repeatedly until the words MANUAL MODE reappear in the CROSSOVER TRAINING display.

4. Begin Pedaling and Select a Resistance Level.

When you begin pedaling, the TOTAL TIME display will be started. This display can be started and stopped with the START/STOP button.

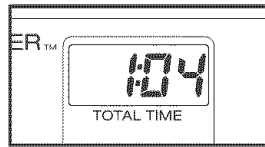

The resistance of the pedals can be set at any of ten levels. To select a resistance level, press the RESISTANCE + and - buttons. The selected resistance level will be displayed in the ELLIPTICAL TRAINING display.

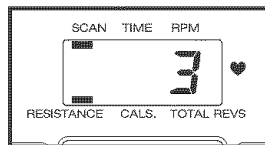

5. Select a Display Mode.

When the SCAN indicator appears, the ELLIPTICAL TRAINING display will show six display modes in succession: RPM, TIME, PULSE, RESISTANCE, CALORIES, and TOTAL REVOLUTIONS.

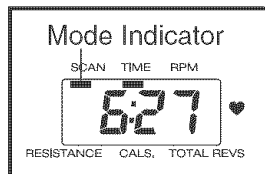

To select a single display mode, press the MODE button repeatedly until the desired mode indicator appears; make sure that the SCAN indicator does not appear. To reselect the SCAN display mode, press the MODE button until the SCAN indicator appears.

To reset the display modes to their default settings, press the RESET button. The SCAN display mode will be selected.

6. Measure Your Heart Rate if Desired.

If there are thin sheets of plastic on the metal contacts on the pulse sensors, peel off the plastic. Place your hands on the pulse sensors, with your palms on the metal contacts. **Avoid moving your hands.** When your pulse is detected, two or three dashes (---) will appear in the ELLIPTICAL TRAINING display and then your heart rate will be shown. For the most accurate heart rate reading, continue to hold the pulse sensors for about 30 seconds. Note: If you continue to hold the pulse sensors, the display will show your heart rate for 30 seconds. The display will then show your heart rate along with the other display modes.

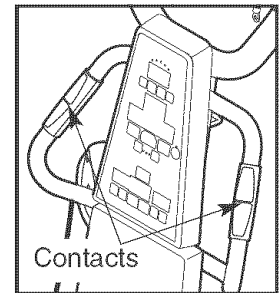

If your heart rate is not shown, make sure that your hands are positioned as described. Avoid moving your hands excessively or squeezing the metal contacts too tightly. For optimal performance, periodically clean the metal contacts using a soft cloth; **never use alcohol, abrasives, or chemicals.**

7. Unplug the Transformer.

When you finish your workout, unplug the transformer from the 120-volt outlet.

PROGRAM OPERATION

The console offers a level 1 (beginning) elliptical training program, two level 2 (intermediate) programs, and three level 3 (advanced) programs. **To use an elliptical training program, first follow steps 1 and 2 at the left. Then, follow the steps below.**

3. Select an elliptical training program.

To select one of the six elliptical training programs, press the ELLIPTICAL TRAINING

PROGRAMS button repeatedly. When an elliptical training program is selected, the name of the selected program will appear in the CROSSOVER TRAINING display. The ELLIPTICAL TRAINING display will show how long the program will last.

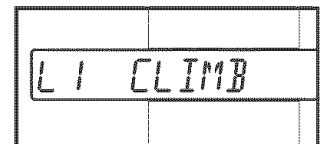

4. Begin Pedaling or Press the START/STOP Button to Start the Program.

When you begin pedaling, the TOTAL TIME display will be started. This display and the program can be started and stopped with the START/STOP button.

Each program consists of several time periods of different lengths. One resistance setting and one target pace are programmed for each segment.

At the end of each period of the program, a tone will sound. If a different resistance setting is programmed for the next period, the resistance setting will flash in the ELLIPTICAL TRAINING display, a series of tones will sound, and the resistance of the pedals will change. Note: You can override the resistance setting, if desired, by pressing the RESISTANCE + and – buttons. However, when the next period begins, the resistance will change if a different resistance setting is programmed for the next period.

5. Use the RPM Pace Guide.

During elliptical training programs, the RPM pace guide above the ELLIPTICAL TRAINING display will indicate whether you are pedaling at the target pace.

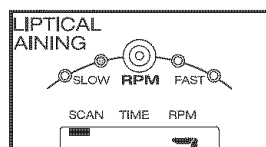

When one of the lights on the left side of the pace guide lights, increase your pedaling pace. When one of the lights on the right side of the pace guide lights, decrease your pace. When the center light is lit, maintain your current pace.

Important: The target pace is intended only to provide a goal. Make sure to pedal at a pace that is comfortable for you.

6. Select a Display Mode and Measure Your Heart Rate if Desired.

See steps 5 and 6 on page 15.

7. Unplug the Transformer.

When you complete your workout, unplug the transformer from the 120-volt outlet.

IFIT.COM PROGRAM OPERATION

To use an iFIT.com program with the elliptical trainer, see IFIT.COM ELLIPTICAL TRAINING on page 19.

STRENGTH TRAINING

MANUAL OPERATION

1. Plug In the Transformer.

See PLUGGING IN THE ELLIPTICAL TRAINER on page 14. **Important: Always plug in the transformer when using the elliptical trainer.**

2. Collapse the Seat Base.

See EXTENDING THE SEAT BASE on page 12.

3. Select the Manual Mode.

When the transformer is plugged in, the manual mode will be selected. If you have already selected a program, press the STRENGTH TRAINING PROGRAMS button repeatedly until the words MANUAL MODE reappear in the CROSSOVER TRAINING display.

4. Select a Resistance Setting for the First Exercise that You Plan to Do.

The current resistance setting will appear in the SYSTEM RESISTANCE display. To change the resistance setting, first **make sure that no cables are being pulled.**



Next, press the SYSTEM RESISTANCE + and – buttons. Each time a button is pressed, the resistance setting will change by 1 pound. To change the resistance setting quickly, hold down one of the buttons.

Note: While the resistance setting is changing, the motor will be heard. **To prevent damage to the motor, do not pull any of the cables while the resistance setting is changing.** If a cable is pulled, the words RELEASE HANDLES AND READJUST RESISTANCE AS DESIRED may appear in the CROSSOVER TRAINING display.

5. Enter the Numbers of Sets and Repetitions that You Plan to Do.

To enter the number of sets that you plan to do, press the SETS + and – buttons. To enter the number of repetitions that you plan to do, press the REPS + and – buttons.

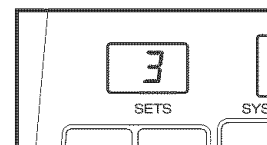

Note: If you do not enter the numbers of sets and repetitions that you plan to do, the console will count the total number of repetitions that you do during your workout.

6. Perform the Exercise.

When you begin exercising, the TOTAL TIME display will be started. This display can be started and stopped with the START/STOP button.

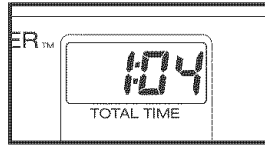

If you have entered numbers of sets and repetitions, the console will count down the repetitions and sets you have completed.

Note: The elliptical trainer uses progressive resistance. As the ends of the cable begin to be pulled, the resistance will increase gradually. As the cable ends are pulled farther, the resistance will increase rapidly.

When you complete the exercise, repeat steps 4 to 6 for each exercise that you wish to do.

7. Unplug The Transformer.

When you complete your workout, unplug the transformer from the 120-volt outlet.

PROGRAM OPERATION

The console offers two ab and back strength training programs, two upper body programs, and two lower body programs. **To use a strength training program, first follow steps 1 and 2 on page 16. Then, follow the steps below.**

3. Designate Yourself as User 1, 2, or 3.

During strength training and crossover training programs, a resistance setting is programmed for each strength exercise. If you change the resistance setting, the console will remember your setting and use it the next time you use the program. The console can remember settings for three different users.

To designate yourself as user 1, 2, or 3, press the SELECT USER button. Make sure to select the same user number each time you use a strength training or crossover training program.

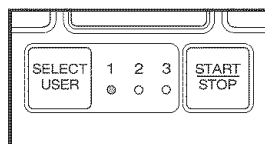

4. Select a Strength Training Program.

To select one of the six strength training programs, press the STRENGTH TRAINING PROGRAMS button

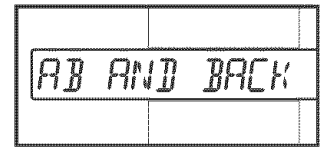

repeatedly. When a strength training program is selected, the name of the selected program will appear in the CROSSOVER TRAINING display for a few seconds. The name of the first exercise in the program will then be displayed.

5. Perform the Exercise.

The resistance setting and the numbers of sets and repetitions for the first exercise will appear in the SYSTEM RESISTANCE, SETS, and REPS displays. The resistance setting and the numbers of sets and repetitions may be too high or too low for you, depending on such factors as your body size and your physical condition. If desired, adjust the resistance setting and the numbers of sets and repetitions by pressing the buttons below the three displays.

When you begin exercising, the TOTAL TIME display will be started. This display and the program can be started and stopped with the START/STOP button.

As you perform the exercise, the console will count down the sets and repetitions you have completed. A tone will sound each time a repetition is performed, and two tones will sound when all of the sets for the exercise are completed.

After you have completed the exercise, press the NEXT button; the name of the next exercise in the program will appear in the CROSSOVER TRAINING display. **Repeat this step for the next exercise.**

When you complete the program, the words WORKOUT COMPLETE will appear in the main display.

6. Unplug the Transformer.

When you complete your workout, unplug the transformer from the 120-volt outlet.

CROSSOVER TRAINING

The console offers ten crossover training programs that combine elliptical exercise with strength training exercises. **To use a crossover training program, follow the steps below.**

1. Plug In the Transformer.

See PLUGGING IN THE ELLIPTICAL TRAINER on page 14. **Important: Always plug in the transformer when using the elliptical trainer.**

2 Designate Yourself as User 1, 2, or 3.

See step 3 on page 17.

3. Select a Crossover Training Program.

To select one of the ten crossover training programs, press the CROSSOVER TRAINING PROGRAMS button

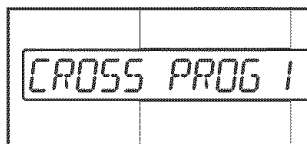

repeatedly. When a crossover training program is selected, the number of the selected program will appear in the CROSSOVER TRAINING display.

4. Press the START/STOP Button to Start the Program.

When the program is started, the TOTAL TIME display will be started. This display and the program can be started and stopped with the START/STOP button.

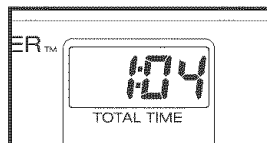

When the program begins, the word ELLIPTICAL and a time period of 3 or 4 minutes will appear in the CROSSOVER TRAINING display. Extend the seat base and begin pedaling. Continue to pedal while the time is counted down in the display.

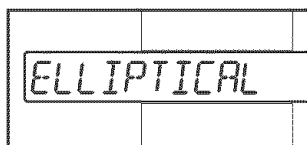

When the time in the CROSSOVER TRAINING display reaches 00:00, the name of the first strength exercise and a time period of 2 minutes will appear in the display. Collapse the seat base, and perform as many repetitions of the exercise as you can while the time is counted down in the display. Note: If desired, change the resistance setting by pressing the SYSTEM RESISTANCE + and – buttons.

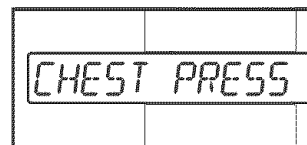

When the time in the CROSSOVER TRAINING display reaches 00:00, the name of the next strength exercise and a time period of 1 minute will appear in the display. Perform as many repetitions of the next exercise as you can while the time is counted down in the display.

After you have performed strength exercises, the word ELLIPTICAL and a time period will again appear in the CROSSOVER TRAINING display. Extend the seat base and begin pedaling. Continue pedaling while the time is counted down in the display.

The program will continue in this way. When you complete the program, the words WORKOUT COMPLETE will appear in the main display.

5. Unplug the Transformer.

When you complete your workout, unplug the transformer from the 120-volt outlet.

IFIT.COM CD AND VIDEO PROGRAMS

To use iFIT.com CDs or videocassettes, the elliptical trainer must be connected to your portable CD player, portable stereo, home stereo, computer with CD player, or VCR. See HOW TO CONNECT YOUR CD PLAYER, VCR, OR COMPUTER on pages 20 and 21. **To purchase iFIT.com CDs and videocassettes, call toll-free 1-833-533-1333. Follow the steps below to use an iFIT.com CD or video program.**

1. Plug In the Transformer.

See PLUGGING IN THE ELLIPTICAL TRAINER on page 14. **Important: Always plug in the transformer when using the elliptical trainer.**

2. Extend the Seat Base.

See EXTENDING THE SEAT BASE on page 12.

3. Select the iFIT.com Mode.

To select the iFIT.com mode, press the iFIT.com button. The indicator above the button will light, and the words IFIT MODE will appear in the CROSSOVER TRAINING display.

4. Insert the iFIT.com CD or Videocassette.

If you are using an iFIT.com CD, insert the CD into your CD player. If you are using an iFIT.com videocassette, insert the videocassette into your VCR.

5. Press the Play Button on Your CD Player or VCR.

A moment after the play button is pressed, your personal trainer will begin guiding you through your workout. Simply follow your personal trainer's instructions.

The program will function in almost the same way as an elliptical training program. However, an electronic "chirping" sound will alert you when the resistance of the pedals and/or the target pace is about to change.

Note: If the resistance of the pedals and/or the RPM pace guide does not change when a "chirp" is heard:

- Make sure that the iFIT.com indicator is lit.

- Adjust the volume of your CD player or VCR. If the volume is too high or too low, the console may not detect the program signals.

- Make sure that the audio cable is properly connected and that it is fully plugged in.

6. Unplug the Transformer.

When you complete your workout, unplug the transformer from the 120-volt outlet.

IFIT.COM INTERNET PROGRAMS

Our Web site at www.iFIT.com allows you to play iFIT.com programs directly from the internet. To use programs from our Web site, the elliptical trainer must be connected to your home computer. See HOW TO CONNECT YOUR COMPUTER on page 21. In addition, you must have an internet connection and an internet service provider. A list of specific system requirements is found on our Web site. **To use an iFIT.com program from our Web site, first follow steps 1 to 3 at the left. Then, follow the steps below.**

4. Go to Your Computer and Start an Internet Connection.

5. Start Your Web Browser, if Necessary, and Go to Our Web Site at www.iFIT.com.

6. Follow the Desired Links on Our Web Site to Select a Program.

Read and follow the on-line instructions for using a program.

7. Follow the On-line Instructions to Start the Program.

When you start the program, an on-screen countdown will begin.

8. Begin Exercising on the Elliptical Trainer.

When the on-screen countdown ends, the program will begin. The program will function in almost the same way as an elliptical training program. However, an electronic "chirping" sound will alert you when the resistance of the pedals and/or the target pace is about to change.

9. Unplug the Transformer.

When you complete your workout, unplug the transformer from the 120-volt outlet.

HOW TO CONNECT YOUR CD PLAYER, VCR, OR COMPUTER

To use iFIT.com programs, a stereo audio cable must be plugged into the iFIT jack on the back of the console.

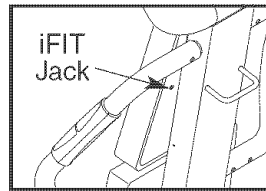

To use iFIT.com CDs, the elliptical trainer must be connected to your portable CD player, portable stereo, home stereo, or computer with CD player. See pages 20 and 21 for connecting instructions. To use iFIT.com videocassettes, the elliptical trainer must be connected to your VCR. See page 21 for connecting instructions. To use iFIT.com programs directly from our Web site, the elliptical trainer must be connected to your home computer. See page 21 for connecting instructions.

HOW TO CONNECT YOUR PORTABLE CD PLAYER

Note: If your CD player has separate LINE OUT and PHONES jacks, see instruction A below. If your CD player has only one jack, see instruction B.

A. Plug one end of a 1/8" to 1/8" stereo audio cable (available at electronics stores) into the console iFIT jack. Plug the other end of the cable into the LINE OUT jack on your CD player. Plug your headphones into the PHONES jack.

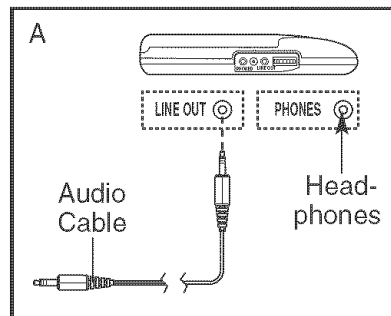

B. Plug one end of a 1/8" to 1/8" stereo audio cable (available at electronics stores) into the console iFIT jack. Plug the other end of the cable into a 1/8" Y-adapter (available at electronics stores). Plug the Y-adapter into the PHONES jack on your CD player. Plug your headphones into the other side of the Y-adapter.

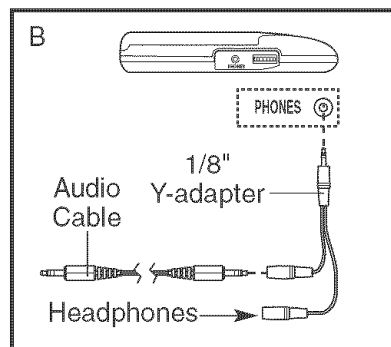

HOW TO CONNECT YOUR PORTABLE STEREO

Note: If your stereo has an RCA-type AUDIO OUT jack, see instruction A below. If your stereo has a 1/8" LINE OUT jack, see instruction B. If your stereo has only a PHONES jack, see instruction C.

A. Plug one end of a 1/8" to RCA stereo audio cable (available at electronics stores) into the console iFIT jack. Plug the other end of the cable into the AUDIO OUT jack on your stereo.

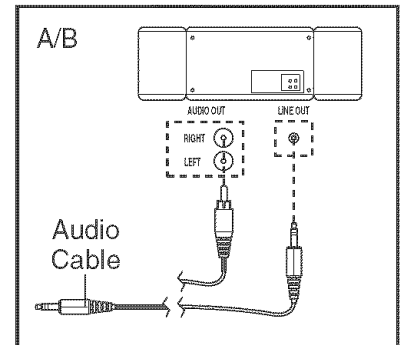

B. See the drawing above. Plug one end of a 1/8" to 1/8" stereo audio cable (available at electronics stores) into the console iFIT jack. Plug the other end of the cable into the LINE OUT jack on your stereo.

C. Plug one end of a 1/8" to 1/8" stereo audio cable (available at electronics stores) into the console iFIT jack. Plug the other end of the cable into a 1/8" Y-adapter (available at electronics stores). Plug the Y-adapter into the PHONES jack on your stereo. Plug your headphones into the other side of the Y-adapter.

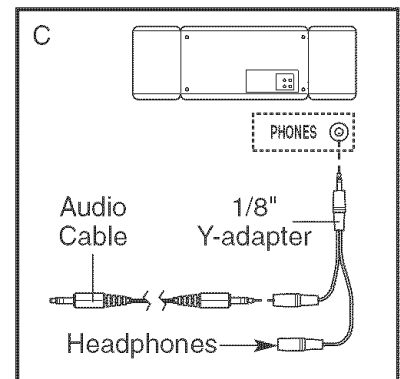

HOW TO CONNECT YOUR HOME STEREO

Note: If your stereo has an unused **LINE OUT** jack, see instruction A below. If the **LINE OUT** jack is being used, see instruction B.

A. Plug one end of a 1/8" to RCA stereo audio cable (available at electronics stores) into the console iFIT jack. Plug the other end of the cable into the **LINE OUT** jack on your stereo.

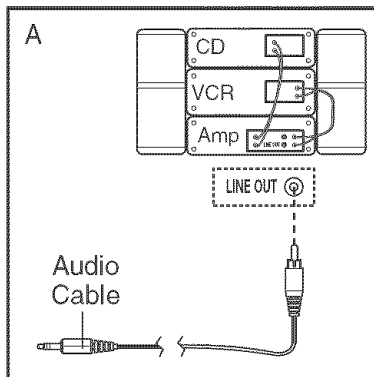

B. Plug one end of a 1/8" to RCA stereo audio cable (available at electronics stores) into the console iFIT.com jack. Plug the other end of the cable into an RCA Y-adapter (available at electronics stores). Next, remove the wire that is currently plugged into the **LINE OUT** jack on your stereo and plug the wire into the unused side of the Y-adapter. Plug the Y-adapter into the **LINE OUT** jack on your stereo.

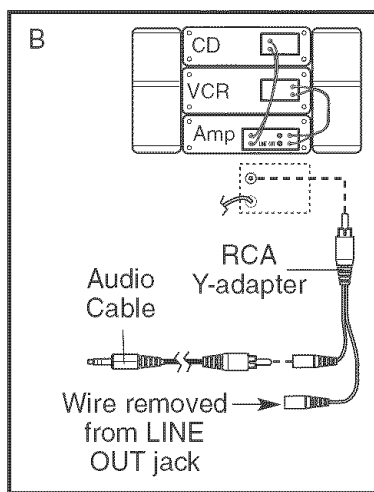

B. Plug one end of a 1/8" to 1/8" stereo audio cable (available at electronics stores) into the jack beneath the console. Plug the other end of the cable into a 1/8" Y-adapter (available at electronics stores). Plug the Y-adapter into the **PHONES** jack on your computer. Plug your headphones or speakers into the other side of the Y-adapter.

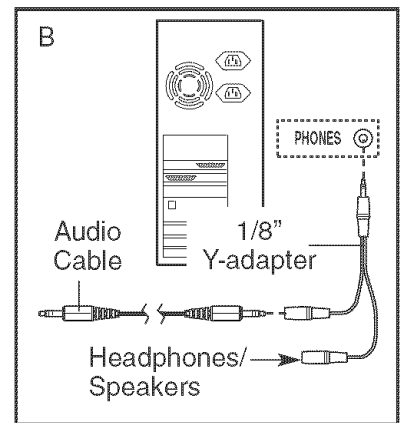

HOW TO CONNECT YOUR VCR

Note: If your VCR has an unused **AUDIO OUT** jack, see instruction A below. If the **AUDIO OUT** jack is being used, see instruction B. If you have a TV with a built-in VCR, see instruction B. If your VCR is connected to your home stereo, see **HOW TO CONNECT YOUR HOME STEREO** on page 20.

A. Plug one end of a 1/8" to RCA stereo audio cable (available at electronics stores) into the console iFIT.com jack. Plug the other end of the cable into the **AUDIO OUT** jack on your VCR.

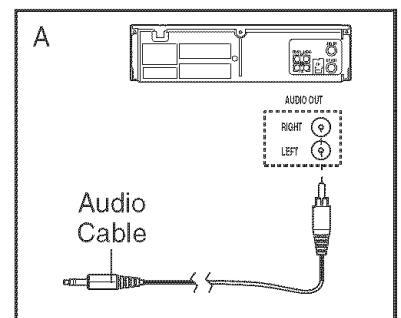

B. Plug one end of a 1/8" to RCA stereo audio cable (available at electronics stores) into the console iFIT.com jack. Plug the other end of the cable into an RCA Y-adapter (available at electronics stores). Next, remove the wire that is currently plugged into the **AUDIO OUT** jack on your VCR and plug the wire into the unused side of the Y-adapter. Plug the Y-adapter into the **AUDIO OUT** jack on your VCR.

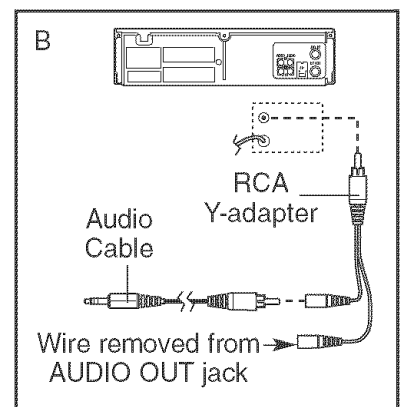

HOW TO CONNECT YOUR COMPUTER

Note: If your computer has a 1/8" **LINE OUT** jack, see instruction A. If your computer has only a **PHONES** jack, see instruction B.

A. Plug one end of a 1/8" to 1/8" stereo audio cable (available at electronics stores) into the jack beneath the console. Plug the other end of the cable into the **LINE OUT** jack on your computer.

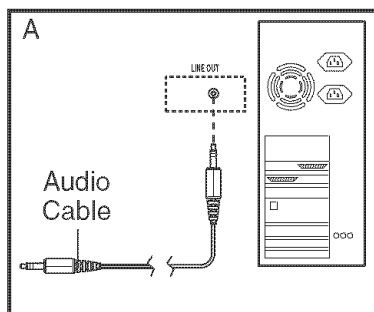

EXERCISE GUIDELINES

THE FOUR BASIC TYPES OF WORKOUTS

Muscle Building

To increase the size and strength of your muscles, push them close to their maximum capacity. Your muscles will continually adapt and grow as you progressively increase the intensity of your exercise. You can adjust the intensity level of an individual exercise in two ways:

- by changing the amount of resistance used.
- by changing the number of repetitions or sets performed. (A “repetition” is one complete cycle of an exercise, such as one sit-up. A “set” is a series of repetitions.)

The proper amount of resistance for each exercise depends upon the individual user. You must gauge your limits and select the amount of resistance that is right for you. Begin with 3 sets of 8 repetitions for each exercise you perform. Rest for 3 minutes after each set. When you can complete 3 sets of 12 repetitions without difficulty, increase the amount of resistance.

Toning

You can tone your muscles by pushing them to a moderate percentage of their capacity. Select a moderate amount of resistance and increase the number of repetitions in each set. Complete as many sets of 15 to 20 repetitions as possible without discomfort. Rest for 1 minute after each set. Work your muscles by completing more sets rather than by using high amounts of resistance.

Weight Loss

To lose weight, use a low amount of resistance and increase the number of repetitions in each set. Exercise for 20 to 30 minutes, resting for a maximum of 30 seconds between sets.

Cross Training

Cross training is an efficient way to get a complete and well-balanced fitness program. An example of a balanced program is:

- Plan strength training workouts on Monday, Wednesday, and Friday.
- Plan 20 to 30 minutes of aerobic exercise, such as running on a treadmill or riding an elliptical exerciser or exercise cycle, on Tuesday and Thursday.
- Rest from both strength training and aerobic exercise for at least one full day each week to give your body time to regenerate.

The combination of strength training and aerobic exercise will reshape and strengthen your body, plus develop your heart and lungs.

PERSONALIZING YOUR EXERCISE PROGRAM

Determining the exact length of time for each workout, as well as the number of repetitions or sets completed, is an individual matter. It is important to avoid overdoing it during the first few months of your exercise program. You should progress at your own pace and be sensitive to your body’s signals. If you experience pain or dizziness at any time while exercising, stop immediately and begin cooling down. Find out what is wrong before continuing. Remember that adequate rest and a proper diet are important factors in any exercise program.

WARMING UP

Begin each workout with 5 to 10 minutes of stretching and light exercise to warm up. Warming up prepares your body for more strenuous exercise by increasing circulation, raising your body temperature and delivering more oxygen to your muscles.

WORKING OUT

Each workout should include 6 to 10 different exercises. Select exercises for every major muscle group, emphasizing areas that you want to develop most. To give balance and variety to your workouts, vary the exercises from session to session.

Schedule your workouts for the time of day when your energy level is the highest. Each workout should be followed by at least one day of rest. Once you find the schedule that is right for you, stick with it.

EXERCISE FORM

Maintaining proper form is an essential part of an effective exercise program. This requires moving through the full range of motion for each exercise, and moving only the appropriate parts of the body. Exercising in an uncontrolled manner will leave you feeling exhausted. On the exercise guide accompanying this manual you will find photographs showing the correct form for several exercises, and a list of the muscles affected. See the muscle chart on the next page to find the names of the muscles.

The repetitions in each set should be performed smoothly and without pausing. The exertion stage of each repetition should last about half as long as the return stage. Proper breathing is important. Exhale during the exertion stage of each repetition and inhale during the return stroke. Never hold your breath.

Rest for a short period of time after each set. The ideal resting periods are:

- Rest for three minutes after each set for a muscle building workout.
- Rest for one minute after each set for a toning workout.
- Rest for 30 seconds after each set for a weight loss workout.

Plan to spend the first couple of weeks familiarizing yourself with the equipment and learning the proper form for each exercise.

COOLING DOWN

End each workout with 5 to 10 minutes of stretching. Include stretches for both your arms and legs. Move

slowly as you stretch and do not bounce. Ease into each stretch gradually and go only as far as you can without strain. Stretching at the end of each workout is an effective way to increase flexibility.

STAYING MOTIVATED

For motivation, keep a record of each workout. List the date, the exercises performed, the resistance used, and the numbers of sets and repetitions completed. Record your weight and key body measurements at the end of every month. Remember, the key to achieving the greatest results is to make exercise a regular and enjoyable part of your everyday life.

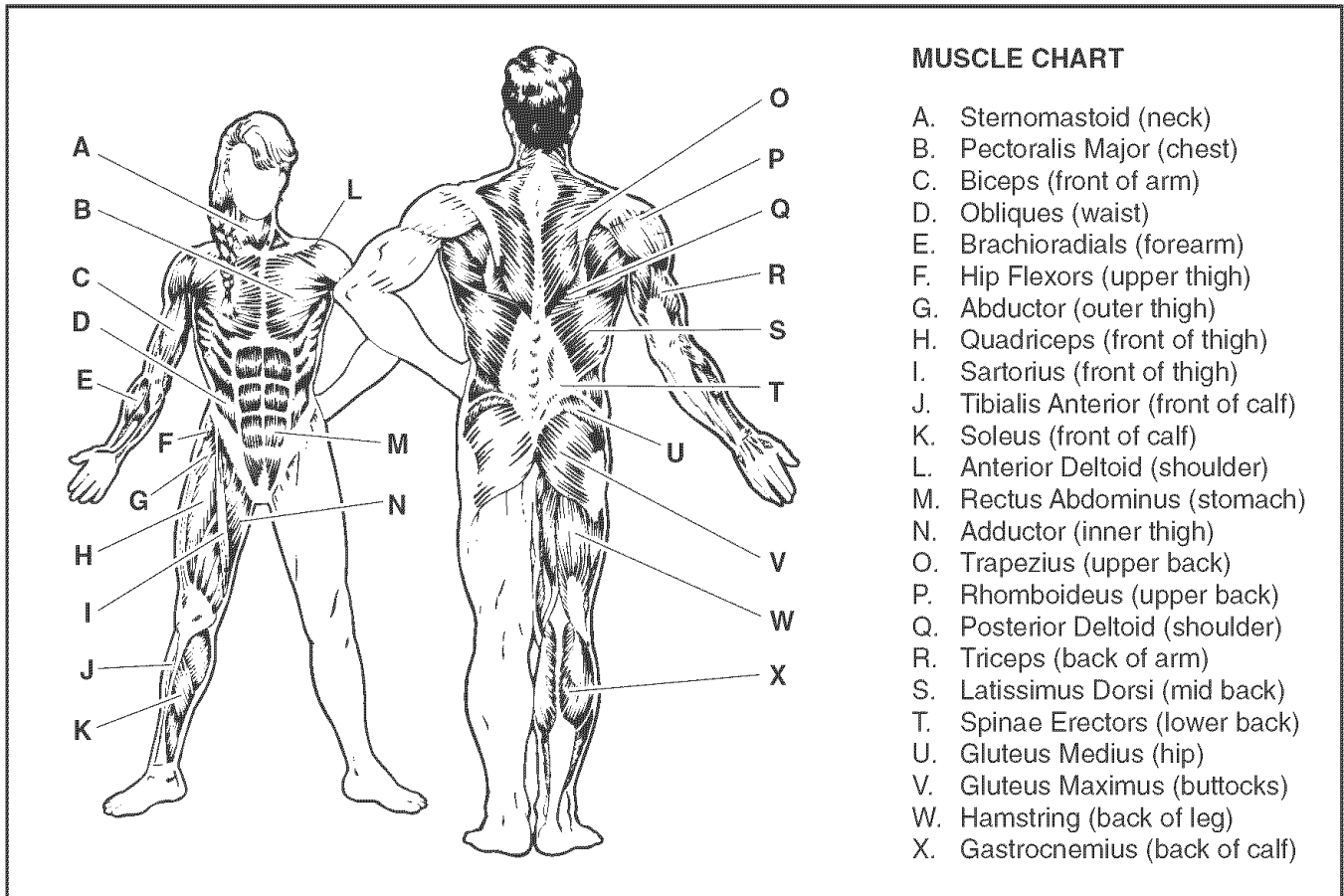

PART IDENTIFICATION CHART

See the drawings below to identify small parts used in assembly. The number in parentheses by each drawing is the key number of the part, from the PART LIST in the center of this manual. **Note: Some small parts may have been pre-attached for shipping purposes. If you cannot find a part in the parts bag, check to see if it has been pre-attached. If a part is missing, call toll-free 1-877-992-5999.**

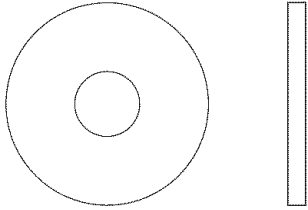

M8 Large Zinc Washer (74)

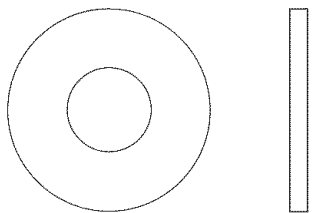

M10 Large Zinc/Black Washer (82, 186)

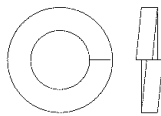

M8 Split Washer (140)



M4 x 5mm Screw (131)



M4 x 16mm Screw (85)

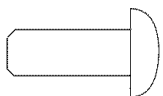

M6 x 16mm Screw (130)

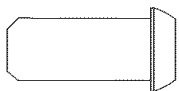

M8 x 19mm Button Screw (94)

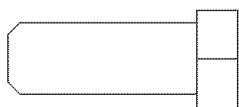

M10 x 25mm Screw (86)

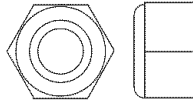

M8 Nylon Locknut (102)

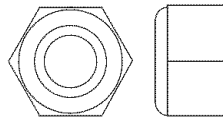

M10 Nylon Locknut (81)

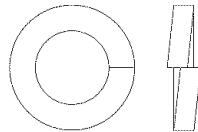

M10 Split Washer (114)

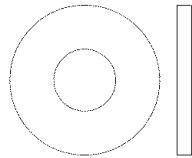

M8 Washer (139)

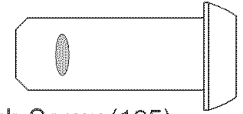

M10 x 25mm Patch Screw (135)

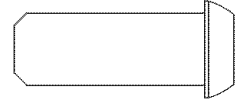

M10 x 25mm Button Screw (87)

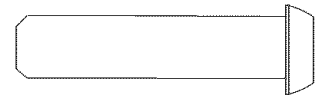

M8 x 36mm Button Bolt (103)

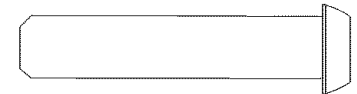

M8 x 40mm Button Screw (142)

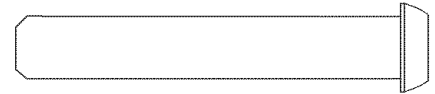

M8 x 51mm Button Screw (98)

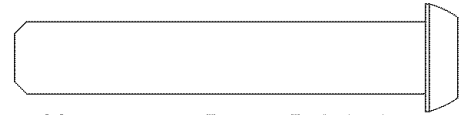

M10 x 54mm Button Bolt (90)

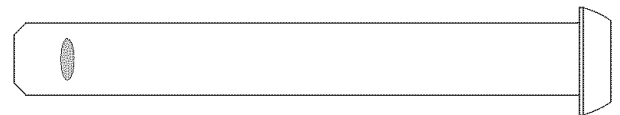

M10 x 75mm Patch Screw (99)

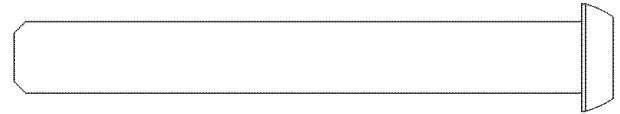

M10 x 75mm Button Bolt (129)

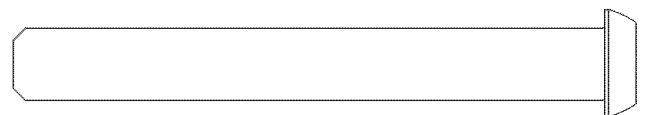

M10 x 78mm Button Screw (101)

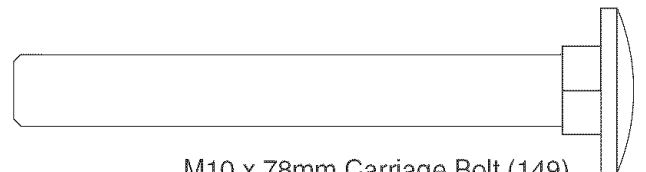

M10 x 78mm Carriage Bolt (149)

PART LIST—Model No. 831.159950

R1204A

Key No.	Qty.	Description	Key No.	Qty.	Description
1	1	Upright Base	55	7	3 1/2" Pulley
2	1	Seat Base	56	2	Band Wheel
3	1	Upright	57	2	Flange Spacer
4	1	Leg Lever	58	4	Swivel Arm
5	1	Left Rail	59	1	Rep Counter
6	1	Right Rail	60	3	Limit Switch
7	1	Left Pedal Leg	61	2	Mech Arm Plate
8	1	Right Pedal Leg	62	1	Bungee Cord
9	1	Seat Stabilizer	63	1	Resistance Motor
10	1	Upright Stabilizer	64	2	Foam Pad
11	1	Top Arm	65	10	Small Base Wheel
12	1	Right Arm	66	2	Disk Hub
13	1	Left Arm	67	2	Double Locknut
14	1	Leg Lever Bracket	68	2	Crank Shaft
15	1	Mech Frame	69	1	System Wire Harness
16	1	Right Handle	70	4	M6 x 12mm Flat Head Screw
17	1	Left Handle	71	1	Console
18	1	Large Belt Pulley	72	2	M8 x 51mm Bolt Set
19	1	Fly Wheel	73	1	Right Rail Cap
20	1	Left Mech Cover	74	2	M8 Large Zinc Washer
21	1	Right Mech Cover	75	2	Arm Cap
22	1	Backrest	76	1	Mech Arm
23	1	Seat	77	1	Motor Assm.
24	1	"C"-magnet	78	2	M10 x 30mm Button Screw
25	1	Right Side Shield	79	1	Lower Pulley Plate
26	1	Left Side Shield	80	2	2 3/4" Pulley
27	1	Left Pedal	81	13	M10 Nylon Locknut
28	1	Right Pedal	82	8	M10 Large Zinc Washer
29	2	Belt Pulley Cover	83	14	Wheel Snap Ring
30	2	Disk Cap	84	2	Flange Screw
31	1	Crank	85	32	M4 x 16mm Screw
32	1	Idler	86	8	M10 x 25mm Screw
33	1	Return Spring	87	2	M10 x 25mm Button Screw
34	1	Guide Rod	88	1	M10 x 89mm Button Bolt
35	1	Resistance Cable	89	2	M10 x 49mm Button Bolt
36	1	Bushing Bracket	90	6	M10 x 54mm Button Bolt
37	1	Middle Wire Harness	91	1	M10 x 48mm Button Bolt
38	1	Leg Lever Bumper	92	6	M3 x 19mm Screw
39	2	Leg Lever Bushing	93	4	M5 x 16mm Screw
40	2	19mm Round Inner Cap	94	2	M8 x 19mm Button Screw
41	1	38mm x 50mm Inner Cap	95	6	Pedal Leg Bearing
42	2	Top Arm Cap	96	2	33mm Spacer
43	2	Pedal Wheel	97	1	Right Base Bushing
44	1	Base Knob	98	4	M8 x 51mm Button Screw
45	1	Left Rail Cap	99	2	M10 x 75mm Patch Screw
46	2	Seat Stabilizer Cap	100	6	M3 Nut
47	2	Stabilizer Wheel	101	2	M10 x 78mm Button Screw
48	4	Foot	102	7	M8 Nylon Locknut
49	1	Left Base Bushing	103	6	M8 x 36mm Button Bolt
50	8	Swivel Bearing	104	2	M6 x 16mm Flat Head Screw
51	5	1 3/4" Pulley	105	2	Pulley Housing
52	4	"V"-pulley	106	3	16mm Spacer
53	2	Resistance Band	107	1	Upper Pulley Plate
54	2	Pulse Sensor/Wire	108	3	M5 Nut

Key No.	Qty.	Description	Key No.	Qty.	Description
109	4	Short Wheel Axle	155	2	Crank Snap Ring
110	4	Wheel Bearing	156	1	Flywheel Snap Ring
111	2	98mm Spacer	157	6	Cable Clip
112	3	51mm Spacer	158	1	Ankle Strap
113	3	Long Wheel Axle	159	2	Wire Harness
114	4	M10 Split Washer	160	2	Hand Strap
115	1	Push Link	161	6	M10 Washer
116	2	Spring	162	1	Rope
117	2	M4 x 25mm Screw	163	2	Short Cable
118	2	Pulley Strap	164	2	Long Cable
119	4	M4 x 12mm Screw	165	1	Transformer
120	1	Power Plug-in	166	1	M4 x 35mm Screw
121	1	M10 x 58mm Button Bolt	167	4	Finger Guard
122	1	M10 x 32mm Button Bolt	168	9	M10 Jam Nut
123	2	13mm Spacer	169	1	M4 Nylon Locknut
124	1	76mm Spacer	170	1	Reed Sensor
125	4	M8 x 15mm Screw	171	2	M6 x 25mm Screw
126	2	Clamp	172	2	15mm Spacer
127	8	M6 Nylon Locknuts	173	1	11mm Spacer
128	4	M5 Nylon Locknut	174	1	Extended Hub Pulley
129	1	M10 x 75mm Button Bolt	175	2	Extension Strap
130	8	M6 x 16mm Screw	176	2	Plastic Washer
131	4	M4 x 5mm Screw	177	2	M10 Split Zinc Washer
132	2	M6 x 90mm Bolt	178	1	Pulley Zinc Washer
133	2	M6 x 112mm Bolt	179	2	M5 x 20mm Screw
134	1	M10 x 116mm Button Bolt	180	2	Plastic Spacer
135	6	M10 x 25mm Patch Screw	181	1	Reed Switch Plate
136	4	M10 x 112mm Button Bolt	182	4	M5 Washer
137	2	M4 x 7mm Screw	183	2	Short Handgrip
138	2	M10 x 16mm Button Screw	184	2	Long Handgrip
139	6	M8 Washer	185	1	Belt
140	6	M8 Split Washer	186	6	M10 Large Black Washer
141	4	Pedal Leg Bushing	187	1	Sensor Wire Harness
142	2	M8 x 40mm Button Screw	188	1	Upper Wire Harness
143	4	M6 x 29mm Flat Head Screw	189	1	M10 x 83mm Bolt Set
144	1	M8 x 37mm Button Screw	190	1	98mm Large Spacer
145	1	Reed Switch	191	2	Rope Cover
146	1	Magnet	192	1	Link
147	4	M6 x 10mm Button Screw	193	1	Lower Clamp
148	1	M8 x 58mm Button Screw	194	1	Upper Clamp
149	2	M10 x 78mm Carriage Bolt	195	2	M5 x 21mm Flat Head Screw
150	1	M6 x 35mm Bolt	#	1	User's Manual
151	2	M6 Nut	#	1	Exercise Guide
152	1	Lower Wire Harness	#	1	Exercise Video
153	4	8mm Spacer	#	2	Allen Wrench
154	2	Upright Stabilizer Cap			

Note: “#” indicates a non-illustrated part. Specifications are subject to change without notice. See the back cover of this manual for information about ordering replacement parts. If a part is missing, call toll-free 1-888-533-1333.

EXPLODED DRAWING—Model No. 831.159950

R1204A

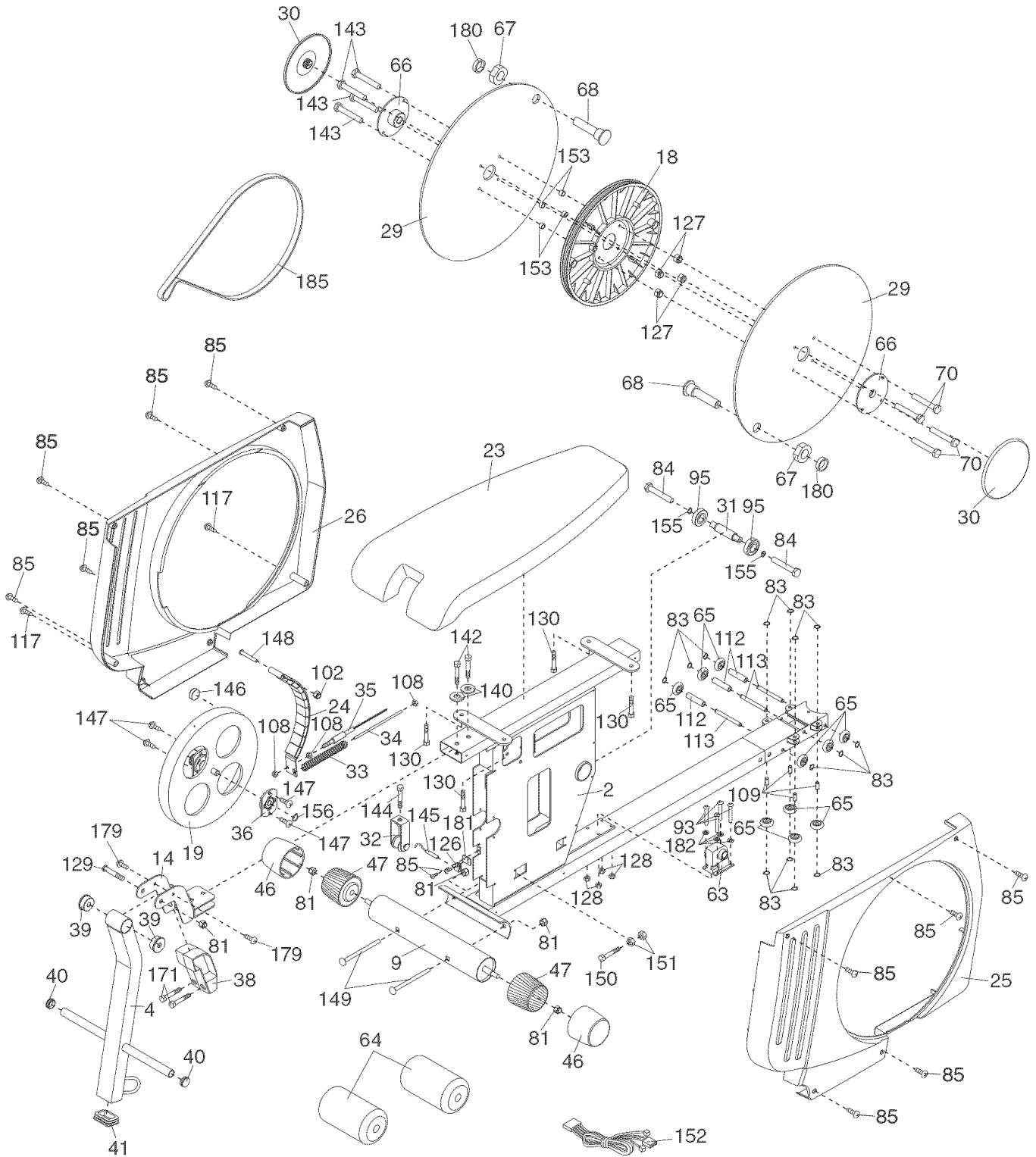

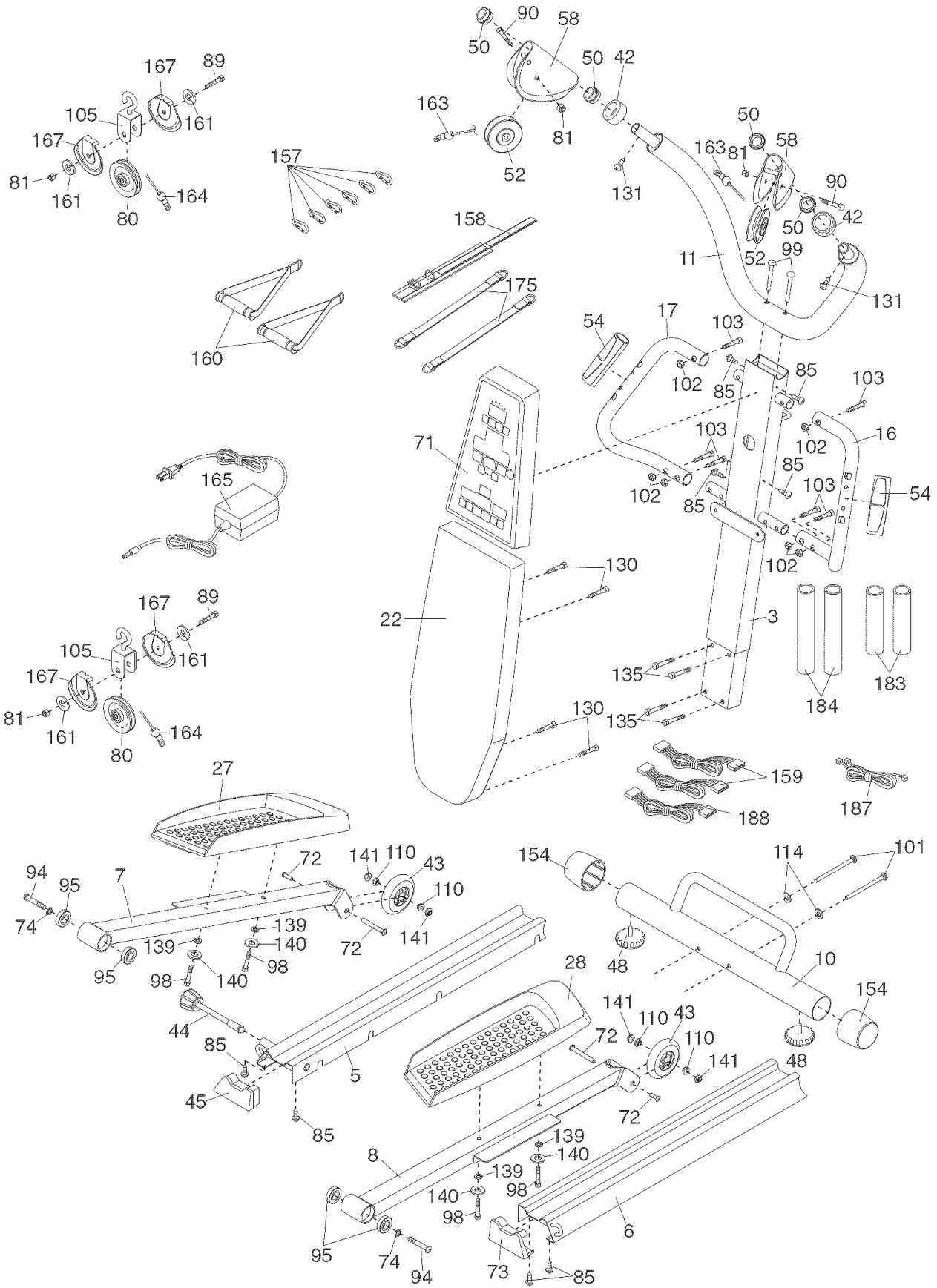

EXPLODED DRAWING—Model No. 831.159950

R1204A

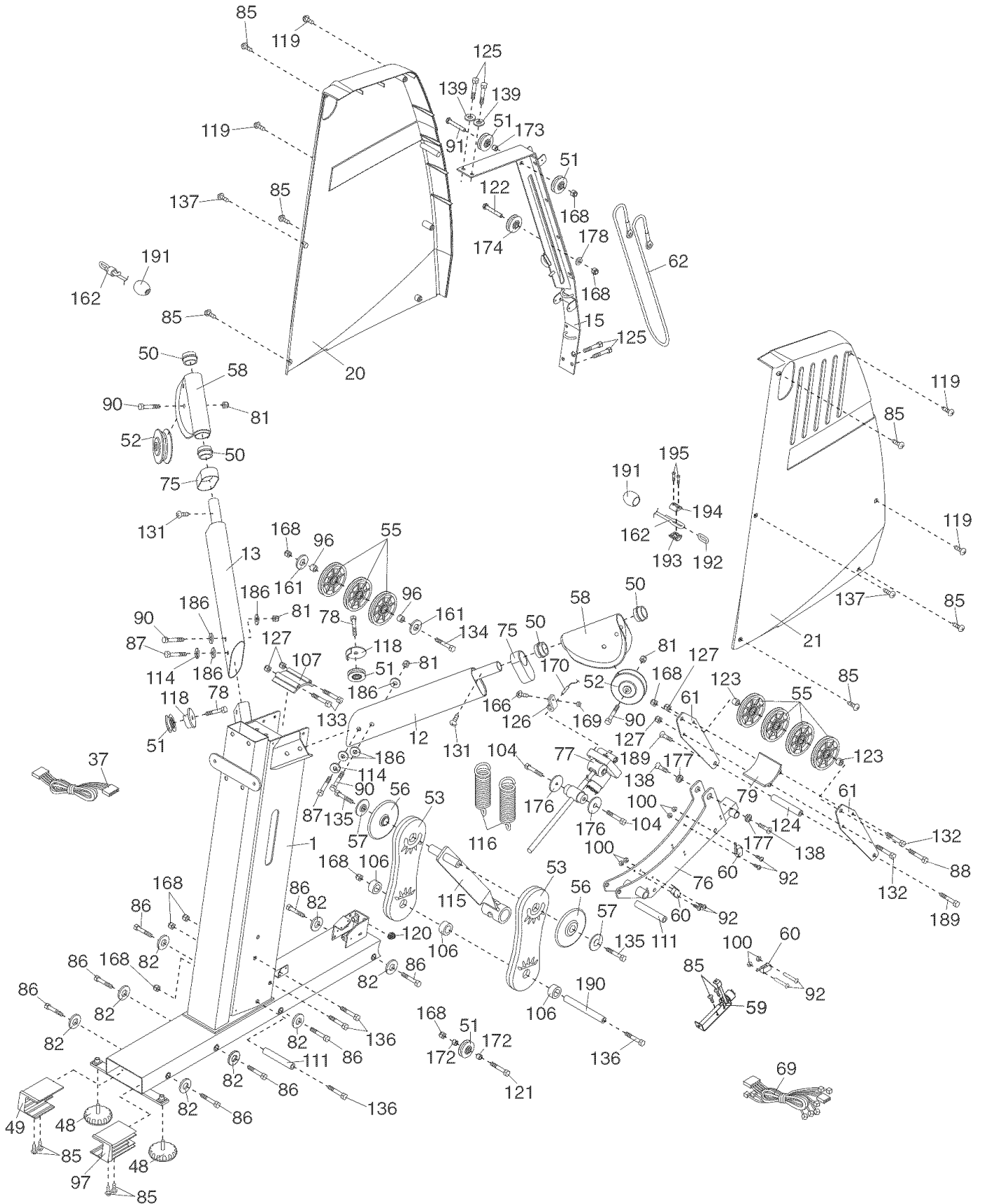

Get it fixed, at your home or ours!

Your Home

For repair – **in your home** – of **all** major brand appliances, lawn and garden equipment, or heating and cooling systems, **no matter who made it, no matter who sold it!**

For the replacement parts, accessories, and user's manuals that you need to do-it-yourself.

For Sears professional installation of home appliances and items like garage door openers and water heaters.

1-800-4-MY-HOME®

(1-800-469-4663)

www.sears.com

Anytime, day or night

(U.S.A. and Canada)

www.sears.ca

Our Home

For repair of carry-in products like vacuums, lawn equipment, and electronics, call or go on-line for the location of your nearest **Sears Parts and Repair Center.**

1-800-488-1222 Anytime, day or night (U.S.A. only)

www.sears.com

To purchase a protection agreement (U.S.A.) or maintenance agreement (Canada) on a product serviced by Sears:

1-800-827-6655 (U.S.A.)

1-800-361-6665 (Canada)

Para pedir servicio de reparación a domicilio, y para ordenar piezas:

1-888-SU-HOGARSM (1-888-784-6427)

SEARS

® Registered Trademark / ™ Trademark / ™ Service Mark of Sears, Roebuck and Co.
© Marca Registrada / ™ Marca de Fábrica / ™ Marca de Servicio de Sears, Roebuck and Co.

FULL 90-DAY WARRANTY

For 90 days from the date of purchase, if failure occurs due to defect in material or workmanship in this ELLIPTICAL TRAINER EXERCISER, contact the nearest Sears Service Center throughout the United States and Sears will repair or replace the ELLIPTICAL TRAINER EXERCISER, free of charge.

This warranty does not apply when the ELLIPTICAL TRAINER EXERCISER is used commercially or for rental purposes.

This warranty gives you specific legal rights, and you may also have other rights which vary from state to state.

Sears, Roebuck and Co., Dept 817WA, Hoffman Estates, IL 60179