

Operator's Manual

CRAFTSMAN®

2-Cycle

GAS TRIMMER

Model No. 316.791810

INCREDI-PULL™
UNIQUE STARTING BASE™

with **MAX FIRE™ IGNITION**



CAUTION: Before using this product, read this manual and follow all safety rules and operating instructions.

- SAFETY
- ASSEMBLY
- OPERATION
- MAINTENANCE
- PARTS LIST

Sears, Roebuck and Co., Hoffman Estates, IL 60179, U.S.A.
Visit our website: www.sears.com/craftsman

769-01697

TABLE OF CONTENTS

Warranty	Page 2	Specifications	Page 18
Safety Rules	Pages 3 - 6	Parts List	Pages 19 - 20
Assembly	Page 7	Notes (Intentionally Blank)	Page 21
Oil and Fuel Information	Page 8	CARB / EPA Warranty Information	Page 22
Starting/Stopping Instructions	Page 9	Repair Protection Agreement	Page 23
Operation	Pages 10 - 12	Service Numbers	Back Cover
Maintenance and Repair	Pages 13 - 16		
Troubleshooting	Page 17		

WARRANTY STATEMENT

TWO YEAR LIMITED WARRANTY ON CRAFTSMAN GAS TRIMMER

For two years from the date of purchase, when this Trimmer is used and maintained according to the operator's manual, Sears will repair any defect in material or workmanship free of charge.

This warranty excludes cutting line, spark plug and air filter, which are expendable parts that can wear out from normal use in less than two years.

If this Gas Trimmer is used for commercial or rental purposes, this warranty applies for 30 days from the date of purchase.

WARRANTY SERVICE IS AVAILABLE BY RETURNING THIS TRIMMER TO THE NEAREST SEARS STORE OR SEARS PARTS & REPAIR CENTER IN THE UNITED STATES.

This warranty gives you specific legal rights, and you may also have other rights which vary from state to state.

Sears, Roebuck and Co., Dept. 817 WA, Hoffman Estates, IL 60179

CALIFORNIA PROPOSITION 65 WARNING

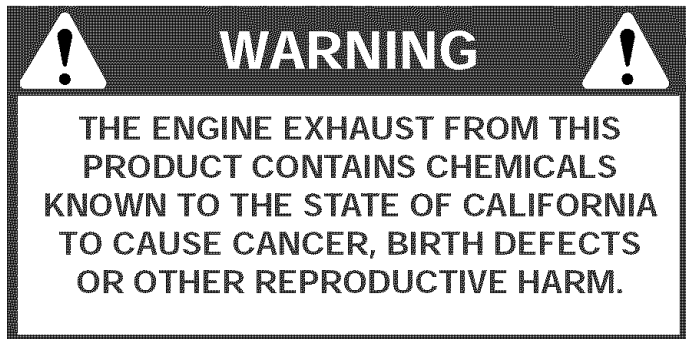

SPARK ARRESTOR NOTE

NOTE: For users on U.S. Forest Land and in the states of California, Maine, Oregon and Washington. All U.S. Forest Land and the state of California (Public Resources Codes 4442 and 4443), Oregon and Washington require, by law that certain internal combustion engines operated on forest brush and/or grass-covered areas be equipped with a spark arrestor, maintained in effective working order, or the engine be constructed, equipped and maintained for the prevention of fire. Check with your state or local authorities for regulations pertaining to these requirements. Failure to follow these requirements could subject you to liability or a fine. **This unit is factory equipped with a spark arrestor.** If it requires replacement, ask a Sears or other qualified service dealer to install the **Accessory Part #753-04689 Spark Arrestor Kit.**

RULES FOR SAFE OPERATION

The purpose of safety symbols is to attract your attention to possible dangers. The safety symbols, and their explanations, deserve your careful attention and understanding. The safety warnings do not by themselves eliminate any danger. The instructions or warnings they give are not substitutes for proper accident prevention measures.

SYMBOL	MEANING
--------	---------

	SAFETY ALERT: Indicates danger, warning or caution. Attention is required in order to avoid serious personal injury. May be used in conjunction with other symbols or pictographs.
---	---

NOTE: Advises you of information or instructions vital to the operation or maintenance of the equipment.

Read the Operator's Manual(s) and follow all warnings and safety instructions.

Failure to do so can result in serious injury to the operator and/or bystanders.

SYMBOL	MEANING
--------	---------

	DANGER: Failure to obey a safety warning will result in serious injury to yourself or to others. Always follow the safety precautions to reduce the risk of fire, electric shock and personal injury.
---	--

	WARNING: Failure to obey a safety warning can result in injury to yourself and others. Always follow the safety precautions to reduce the risk of fire, electric shock and personal injury.
---	--

	CAUTION: Failure to obey a safety warning may result in property damage or personal injury to yourself or to others. Always follow the safety precautions to reduce the risk of fire, electric shock and personal injury.
---	--

• IMPORTANT SAFETY INSTRUCTIONS •

READ ALL INSTRUCTIONS BEFORE OPERATING

	WARNING: When using the unit, you must follow the safety rules. Please read these instructions before operating the unit in order to ensure the safety of the operator and any bystanders. Please keep these instructions for later use.
---	---

- Read the instructions carefully. Be familiar with the controls and proper use of the unit.
- Do not operate this unit when tired, ill or under the influence of alcohol, drugs or medication.
- Children must not operate the unit. Teens must be accompanied and guided by an adult.
- Inspect the unit before use. Replace damaged parts. Check for fuel leaks. Make sure all fasteners are in place and secure. Replace cutting attachment parts that are cracked, chipped or damaged in any way. Make sure the cutting attachment is properly installed and securely fastened. Be sure that the cutting attachment shield is properly attached, and positioned as recommended. Failure to do so can result in personal injury to the operator and bystanders, as well as damage to the unit.
- Use only Hassle Free III™ XTRA QUIET Spiral Line. Never use metal-reinforced line, wire, chain or rope. These can break off and become dangerous projectiles.

- Be aware of risk of injury to the head, hands and feet.
- Clear the area to be cut before each use. Remove rocks, broken glass, nails, wire, string and other objects which may be thrown or become entangled in the cutting attachment. Clear the area of children, bystanders and pets; keep them outside a 50-foot (15 m.) radius, at a minimum. Even then, they are still at risk from thrown objects. Encourage bystanders to wear eye protection. If you are approached, stop the unit immediately.
- Squeeze the throttle control and check that it returns automatically to the idle position. Make all adjustments or repairs before using the unit.
- This unit was not designed to be used as a brushcutter. Do not attach or operate this unit with any type of brushcutting blade or brushcutting attachment.

FUEL SAFETY WARNINGS

	WARNING: Gasoline is highly flammable, and its vapors can explode if ignited. Take the following precautions:
---	--

- Store fuel only in containers specifically designed and approved for the storage of such materials.
- Always stop the engine and allow it to cool before filling the fuel tank. Never remove the fuel tank cap or add fuel when the engine is hot. Never operate the unit without the fuel cap securely in place. Loosen the fuel tank cap slowly to relieve any pressure in the tank.

RULES FOR SAFE OPERATION

- Mix and add fuel in a clean, well-ventilated outdoor area where there are no sparks or flames. Remove the fuel cap slowly, and only after the engine stops. Do not smoke while fueling or mixing fuel. Wipe up any spilled fuel from the unit immediately.
- Avoid creating a source of ignition for spilled fuel. Do not start the engine until fuel vapors dissipate.
- Move the unit at least 30 feet (9.1 m) from the fueling source and site before starting the engine. Do not smoke. Keep sparks and open flames away from the area while adding fuel or operating the unit.

WHILE OPERATING

- Never start or run the unit inside a closed room or building. Breathing exhaust fumes can be fatal. Operate this unit only in a well-ventilated outdoor area.
- Wear safety glasses or goggles that meet ANSI Z87.1 standards and are marked as such. Wear ear/hearing protection when operating this unit. Wear a face or dust mask if the operation is dusty.
- Wear heavy long pants, boots, gloves and a long sleeve shirt. Do not wear loose clothing, jewelry, short pants, sandals or go barefoot. Secure hair above shoulder level.
- The cutting attachment shield must always be in place while operating the unit. Do not operate unit without both trimming lines extended, and the proper line installed. Do not extend the trimming line beyond the length of the shield.
- This unit has a clutch. The cutting attachment remains stationary when the engine is idling. If it does not, take the unit to a Sears or other qualified service dealer for an adjustment.
- Adjust the D-handle to your size in order to provide the best grip.
- Be sure the cutting attachment is not in contact with anything before starting the unit.
- Use the unit only in daylight or good artificial light.
- Avoid accidental starting. Be in the starting position whenever pulling the starter rope. The operator and unit must be in a stable position while starting. Refer to *Starting/Stopping Instructions*.
- Use the right tool. Only use this tool for its intended purpose.
- Do not overreach or use on unstable surfaces such as ladders, trees, steep slopes, rooftops, etc. Always keep proper footing and balance.
- Always hold the unit with both hands when operating. Keep a firm grip on both handles or grips.
- Keep hands, face, and feet away from all moving parts. Do not touch or try to stop the cutting attachment when it rotates.
- Keep outside surfaces free from oil and fuel.
- Do not touch the engine, gear housing or muffler. These parts get extremely hot from operation, even after the unit is turned off.

- Do not operate the engine faster than the speed needed to cut, trim or edge. Do not run the engine at high speed when not cutting.
- Always stop the engine when cutting is delayed or when walking from one cutting location to another.
- If you strike or become entangled with a foreign object, stop the engine immediately and check for damage. Do not operate before repairing damage. Do not operate the unit with loose or damaged parts.
- Turn the engine to off and disconnect the spark plug for maintenance or repair.
- Use only replacement parts or accessories recommended for this tool that are sold by Sears or a Craftsman outlet. Use of any replacement parts or accessories purchased elsewhere may be hazardous, and will also void your warranty.
- Keep unit clean of vegetation and other materials. They may become lodged between the cutting attachment and shield.
- To reduce fire hazard, replace a faulty muffler and spark arrestor. Keep the engine and muffler free from grass, leaves, excessive grease or carbon build up.

OTHER SAFETY WARNINGS

- Never store the unit, with fuel in the tank, inside a building where fumes may reach an open flame (pilot lights, etc.) or sparks (switches, electrical motors, etc.).
- Allow the engine to cool before storing or transporting. Be sure to secure the unit while transporting.
- Store the unit in a dry place, secured or at a height to prevent unauthorized use or damage. Keep out of the reach of children.
- Never douse or squirt the unit with water or any other liquid. Keep handles dry, clean and free from debris. Clean after each use, see *Cleaning and Storage* instructions.
- Keep these instructions. Refer to them often and use them to instruct other users. If you loan this unit to others, also loan them these instructions.
- **SPECIAL NOTE:** Exposure to vibrations through prolonged use of gasoline- powered hand tools could cause blood vessel or nerve damage in the fingers, hands, and joints of people prone to circulation disorders or abnormal swelling. Prolonged use in cold weather has been linked to blood vessel damage in otherwise healthy people. If symptoms occur such as numbness, pain, loss of strength, change in skin color or texture, or loss of feeling in the fingers, hands or joints, discontinue use of this tool and seek medical attention. A reduced vibration system does not guarantee avoidance of these problems. Users who operate power tools on a regular basis must closely monitor their physical condition and the condition of this tool.

**SAVE THESE
INSTRUCTIONS**

RULES FOR SAFE OPERATION

SAFETY AND INTERNATIONAL SYMBOLS

This operator's manual describes safety and international symbols and pictographs that may appear on this product. Read the operator's manual for complete safety, assembly, operating and maintenance and repair information.

SYMBOL



MEANING

- **SAFETY ALERT SYMBOL**

Indicates danger, warning, or caution. May be used in conjunction with other symbols or pictographs.



- **READ OPERATOR'S MANUAL**

WARNING: Read the Operator's Manual(s) and follow all warnings and safety instructions. Failure to do so can result in serious injury to the operator and/or bystanders.



- **WEAR EYE AND HEARING PROTECTION**

WARNING: Thrown objects and loud noise can cause severe eye injury and hearing loss. Wear eye protection meeting ANSI Z87.1-1989 standards and ear protection when operating this unit. Use a full face shield when needed.



- **KEEP BYSTANDERS AWAY**

WARNING: Keep all bystanders, especially children and pets, at least 50 feet (15 m.) from the operating area.



- **UNLEADED FUEL**

Always use clean, fresh unleaded fuel.

SYMBOL



MEANING

- **THROWN OBJECTS AND ROTATING CUTTER CAN CAUSE SEVERE INJURY**

WARNING: Do not operate without the cutting attachment shield in place. Keep away from the rotating cutting attachment.



- **ON/OFF STOP CONTROL**

ON / START / RUN



- **ON/OFF STOP CONTROL**

OFF or STOP



- **HOT SURFACE WARNING**

Do not touch a hot muffler or cylinder. You may get burned. These parts get extremely hot from operation, even after the unit is turned off.



- **OIL**

Refer to operator's manual for the proper type of oil.

RULES FOR SAFE OPERATION

KNOW YOUR TRIMMER

APPLICATIONS

- Cutting grass and light weeds
- Edging
- Decorative trimming around trees, fences, etc.

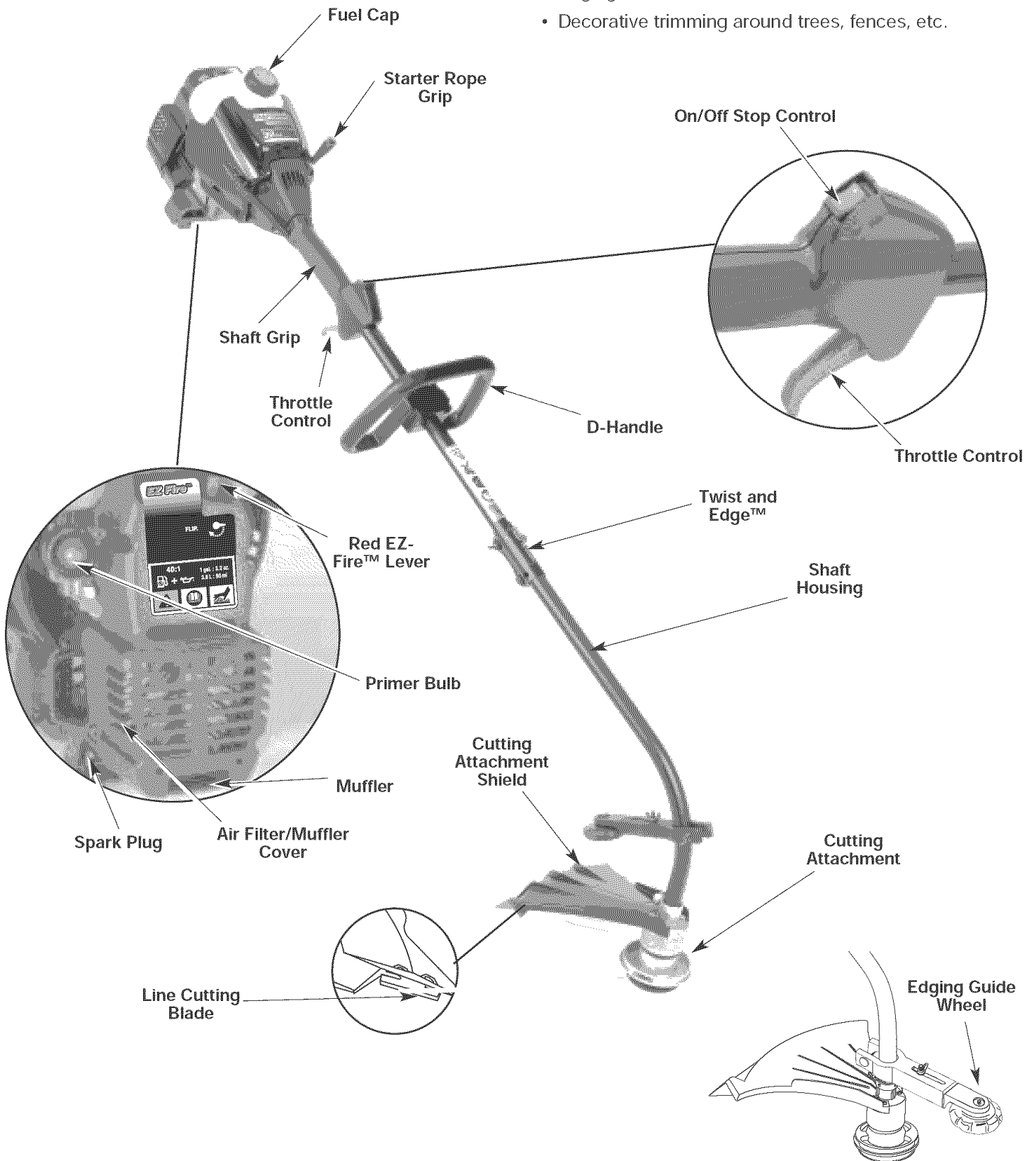

ASSEMBLY INSTRUCTIONS

INSTALL AND ADJUST THE D-HANDLE

Install

1. Place the D-handle down on to the shaft housing and the bottom clamp so that the handle slants towards the shaft grip (Fig. 1). Place handle and clamp a minimum of 6 inches from the end of the shaft grip.
2. Start screws with a large Flat-head or T-25 Torx screwdriver. Do not tighten until you make the handle adjustment.

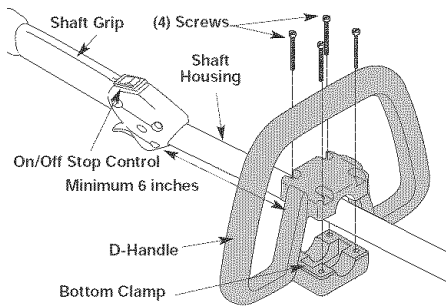

Fig. 1

Adjust

3. While holding the unit in the operating position, position the D-handle to the location that provides you the best grip.
4. Tighten the clamp screws evenly until the D-handle is secure.

INSTALL THE CUTTING ATTACHMENT SHIELD



WARNING: Never operate the trimmer without the cutting attachment shield in place to prevent serious personal injury.

Use the following instructions if the cutting attachment shield on your unit is not installed.

1. Place the cutting attachment shield onto the shaft housing above the clamp assembly (Fig. 2).
2. Lower the cutting attachment shield down to the top of the cutting attachment assembly and then rotate the cutting attachment shield until the screw holes align and the guard fits into the recessed pocket (Fig. 3).

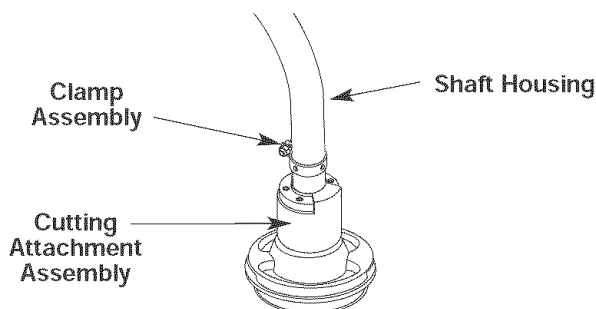

Fig. 2

3. Install the screws with a Phillips screwdriver (Fig. 4).

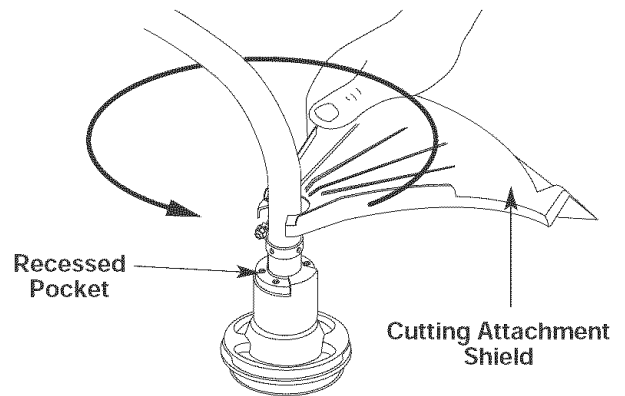

Fig. 3

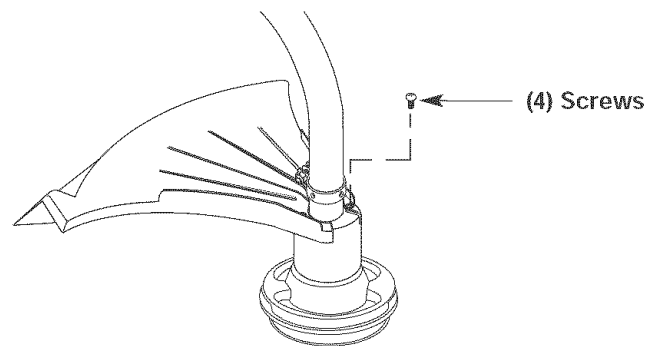

Fig. 4

EDGE GUIDE WHEEL

1. Push edge guide wheel onto the shaft just above the cutting attachment shield (Fig. 5). Some force may be required. The depth adjustment nut must be on top.
2. Install the bolt, washer and wing nut. Tighten securely.
3. Adjust the edging depth by loosening the depth adjustment nut. Then move the guide wheel along the path shown by the arrows (Fig. 5) until the wheel reaches the desired position and then tighten securely.

For instructions on how to operate the edge guide wheel, refer to page 11.

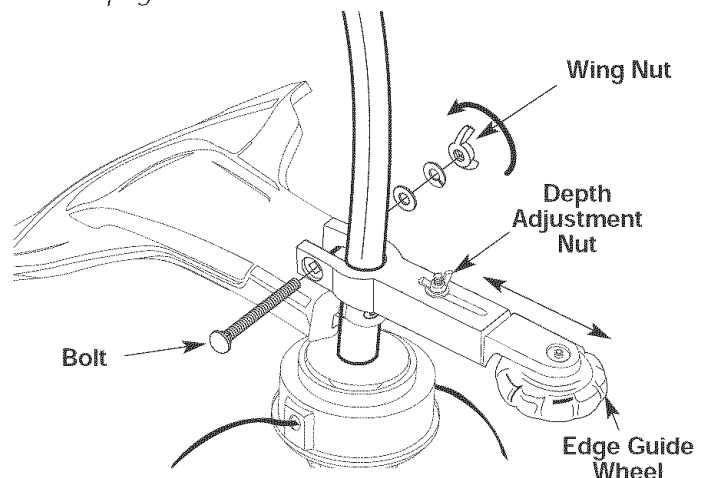

Fig. 5

OIL AND FUEL INFORMATION

OIL AND FUEL MIXING INSTRUCTIONS

Old and/or improperly mixed fuel are the main reasons for the unit not running properly. Be sure to use fresh (less than 60 days old), clean unleaded fuel. Follow the instructions carefully for the proper fuel/oil mixture.

Definition of Blended Fuels

Today's fuels are often a blend of gasoline and oxygenates such as ethanol, methanol, or MTBE (ether). Alcohol-blended fuel absorbs water. As little as 1% water in the fuel can make fuel and oil separate and leads to formation of acids during storage. When using alcohol-blended fuel, use fresh fuel.

Using Blended Fuels

If you choose to use a blended fuel, or its use is unavoidable, follow recommended precautions:

- Always use the fresh fuel mix explained in your operator's manual
- Always shake the fuel mix before fueling the unit
- Drain the tank and run the engine dry before storing the unit

Using Fuel Additives

The bottle of 2-cycle oil that came with your unit contains a fuel additive which will help inhibit corrosion and minimize the formation of gum deposits. It is recommended that you always use Craftsman 2-cycle oil with this unit.

If Craftsman 2-cycle oil is unavailable, use a good 2-cycle oil designed for air-cooled engines along with a fuel additive, such as STA-BIL® Gas Stabilizer or an equivalent. Add 0.8 oz. (23 ml.) of fuel additive per gallon of fuel according to the instructions on the container. NEVER add fuel additives directly to the unit's fuel tank.



	CAUTION: For proper engine operation and maximum reliability, pay strict attention to the oil and fuel mixing instructions on the 2-cycle oil container. Using improperly mixed fuel can severely damage the engine.
---	---

To Obtain Correct Fuel Mix:

Thoroughly mix the proper ratio of 2-cycle engine oil with unleaded gasoline in a separate fuel can. Use a 40:1 fuel/oil ratio. Do not mix them directly in the engine fuel tank. See the Fuel Mixture Table for specific gas and oil mixing ratios.

NOTE: One gallon (3.8 liters) of unleaded gasoline mixed with one 3.2 oz. (95 ml.) bottle of 2-cycle oil makes a 40:1 fuel/oil ratio.

FUEL MIXTURE TABLE

	+	
UNLEADED GAS		2 CYCLE OIL
1 GALLON US (3.8 LITERS)		3.2 FL. OZ. (95 ml)
1 LITER		25 ml

MIXING RATIO - 40:1

	WARNING: Gasoline is extremely flammable. Ignited vapors may explode. Always stop the engine and allow it to cool before filling the fuel tank. Do not smoke while filling the tank. Keep sparks and open flames at a distance from the area.
---	--

	WARNING: Remove fuel cap slowly to avoid injury from fuel spray. Never operate the unit without the fuel cap securely in place.
---	--

	WARNING: Add fuel in a clean, well-ventilated outdoor area. Wipe up any spilled fuel immediately. Avoid creating a source of ignition for spilled fuel. Do not start the engine until fuel vapors dissipate.
---	---

NOTE: Dispose of the old fuel/oil mix in accordance to Federal, State and Local regulations.

STARTING/STOPPING INSTRUCTIONS



WARNING: Operate this unit only in a well-ventilated outdoor area. Carbon monoxide exhaust fumes can be lethal in a confined area.



WARNING: Avoid accidental starting. Make sure you are in the starting position when pulling the starter rope (Fig. 8). To avoid serious injury, the operator and unit must be in a stable position while starting.

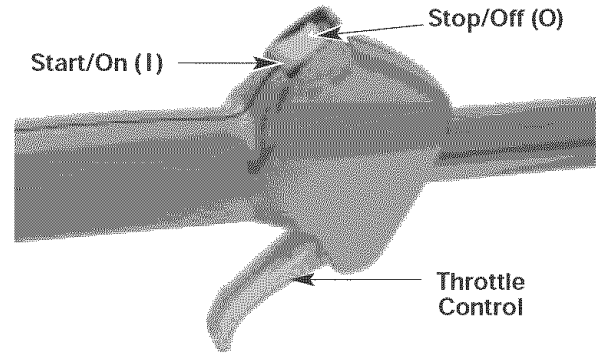

Fig. 6

STARTING INSTRUCTIONS

1. Mix gas with oil. Fill fuel tank with fuel/oil mixture. See *Oil and Fuel Mixing Instructions*.
2. Make sure the On/Off Stop Control is in the **ON [I]** position (Fig. 6).
3. Fully press and release the primer bulb 10 times, slowly. Some amount of **fuel should be visible in the primer bulb** and fuel lines (Fig. 7). If you can't see fuel in the bulb, press and release the bulb as many times as it takes before you can see fuel in it.
4. Push the red EZ-Fire™ Lever towards the primer bulb until it clicks and locks into place (Fig. 7).

NOTE: The unit uses the **Incredi-Pull™** starting system with **MAX FIRE IGNITION™**, which significantly reduces the effort required to start the engine. You must pull the starter rope out far enough to hear the engine attempt to start. There is no need to pull the rope briskly-- there is no harsh resistance when pulling. Be aware that this starting method is vastly different from (and much easier than) what you may be used to.

5. Crouch in the starting position and **do not squeeze the throttle control** (Fig. 8). Pull the starter rope out with a **controlled and steady motion** up to 10 times, until the engine starts.
6. When the engine starts, squeeze the throttle control for 15 to 30 seconds. This will warm up the unit. **The red EZ-Fire™ lever will click off automatically** when you squeeze the throttle control.

IF... The engine does not start, go back to step 3.

IF... The engine stops *while* you are squeezing the throttle, go back to step 4.

IF... The engine stops *before* you squeeze the throttle control, hold the throttle control and pull the starter rope until the trimmer starts.

NOTE: If you are having trouble starting the unit or are operating in extreme temperatures (below 40° F, above 90° F), refer to the *Troubleshooting* section.

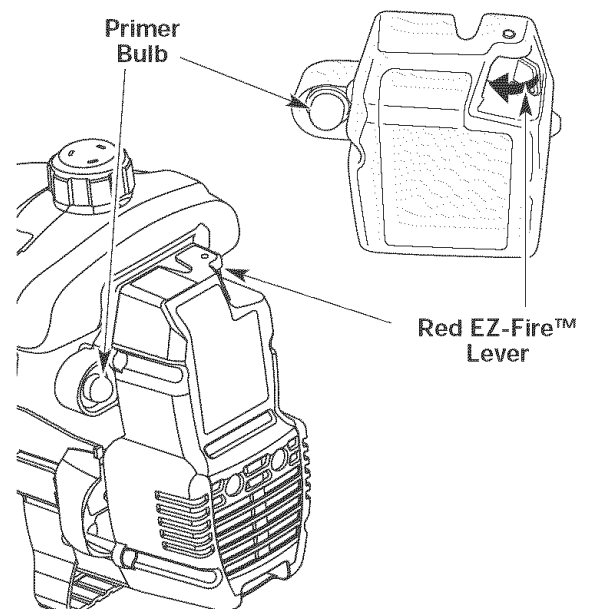

Fig. 7

STOPPING INSTRUCTIONS

1. Release your finger from the throttle control. Allow the engine to cool down by idling.
2. Put the On/Off Stop Control in the OFF (O) position (Fig. 6).

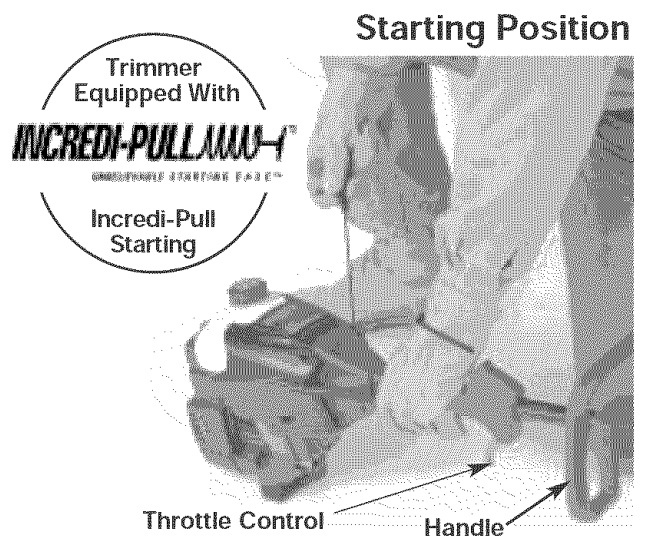

Fig. 8

OPERATING INSTRUCTIONS

HOLDING THE TRIMMER



WARNING: Always wear eye, hearing, foot and body protection to reduce the risk of injury when operating this unit.

Before operating the unit, stand in the operating position (Fig. 9). Check for the following:

- The operator is wearing eye protection and proper clothing
- With a slightly-bent right arm, the operator's hand is holding the shaft grip
- The operator's left arm is straight, the left hand holding the D-handle
- The unit is at waist level
- The cutting attachment is parallel to the ground and easily contacts the grass without the need to bend over

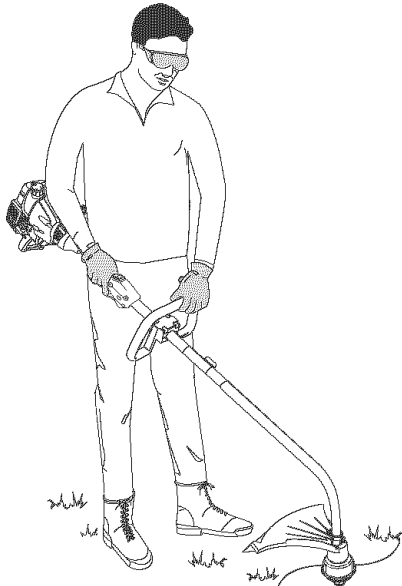

Fig. 9

LINE REPLACEMENT

for Hassle-Free III™ Cutting Head

Always use Craftsman Hassle-Free III™ XTRA QUIET Spiral Line.

Choose the line size best suited for the job at hand. Red colored line is designed for cutting grass and small weeds. Black colored line is designed for cutting larger weeds and light brush.

NOTE: Before inserting new line into the holes in the cutting head, identify the proper holes. Follow directions as shown on the line glide plate. **Do Not** attempt to remove the cutting head from the unit when replacing line.

1. Remove the old line and line glide plate from the cutting head.
2. Clean entire surface of cutting head.
3. Reinstall line glide plate (Fig. 10). Align arrow with:
A- when using medium (red) or large (black) line
B- when using lines with diameters smaller than medium (red) line

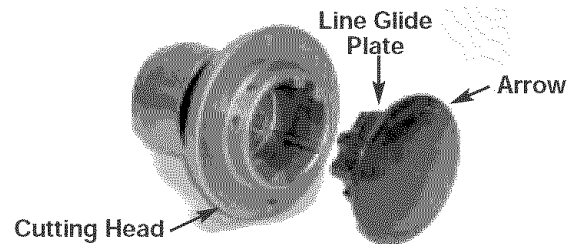

Fig. 10

NOTE: Line glide plate must be reinstalled in cutting head before inserting new line.

4. Insert both ends of your line through the proper holes in the side of the cutting head (Fig. 11).

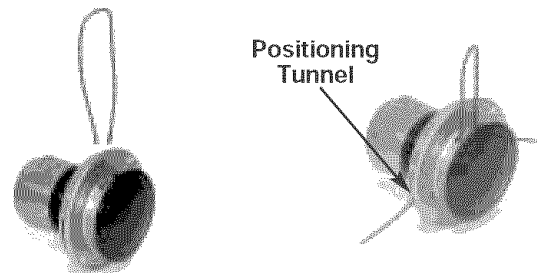

Fig. 11

5. Pull the line and make sure the line is against the hub and is fully extended through the positioning tunnels (Fig. 12).

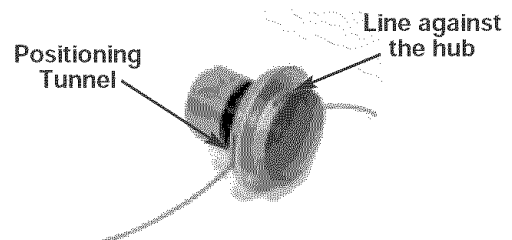

Fig. 12

6. Correctly installed line will be the same length on both sides.

OPERATING INSTRUCTIONS

NOTE: Do not rest the Hassle-Free III™ Cutting Head on the ground while the unit is running.

Some line breakage will occur from:

- Entanglement with foreign matter
- Normal line fatigue
- Attempting to cut thick, stalky weeds
- Forcing the line into objects such as walls or fence posts



WARNING: Do not remove or alter the line cutting blade assembly. Excessive line length will make the clutch overheat. This may lead to serious personal injury or damage to the unit.

TIPS FOR BEST TRIMMING RESULTS

- Keep the cutting attachment parallel to the ground.
- Do not force the cutting attachment. Allow the tip of the line to do the cutting, especially along walls. Cutting with more than the tip will reduce cutting efficiency and may overload the engine.
- Cut grass over 8 inches (200 mm) by working from top to bottom in small increments to avoid premature line wear or engine drag.
- Cut from right to left whenever possible. Cutting to the right improves the unit's cutting efficiency. Clippings are thrown away from the operator.
- Slowly move the trimmer in and out of the cutting area at the desired height. Move either in a forward-backward or side-to-side motion. Cutting shorter lengths produces the best results.
- Trim only when grass and weeds are dry.
- The life of your cutting line is dependent upon:
 - Following the trimming techniques
 - What vegetation is being cut
 - Where vegetation is cut

For example, the line will wear faster when trimming against a foundation wall as opposed to trimming around a tree.

DECORATIVE TRIMMING

Decorative trimming is accomplished by removing all vegetation around trees, posts, fences and more.

Rotate the whole unit so that the cutting attachment is at a 30° angle to the ground (Fig. 13).

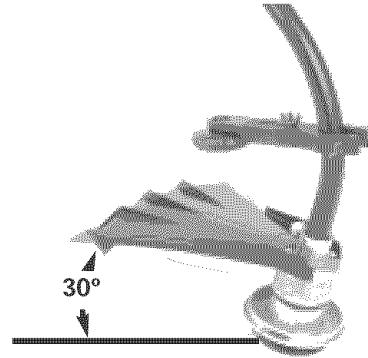

Fig. 13

USING THE TWIST AND EDGE™ FEATURE

You can use the Twist and Edge™ coupler to convert the unit to edge grass:

1. Make sure the unit is turned completely off.
2. Turn the knob counterclockwise to loosen.
3. Grasp the boom below the coupler and firmly twist it 90° in either direction (depending on which way you want to edge).
4. Turn the knob clockwise to tighten (Fig. 14).

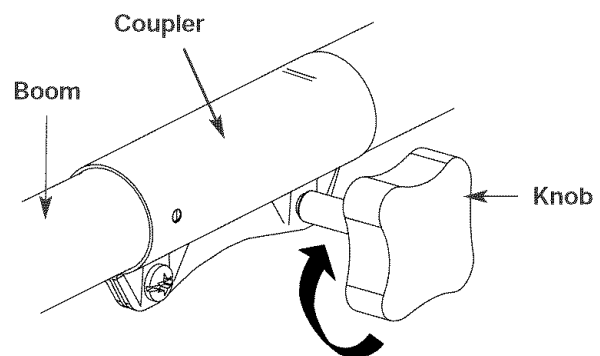

Fig. 14

5. Rotate the edge guide. Accomplish this by loosening its wing nut slightly and turning the guide to the left (when facing the unit away from the engine) Turn the guide about 90° (Fig. 15) or until it is in the position shown in Figure 16.

OPERATING INSTRUCTIONS

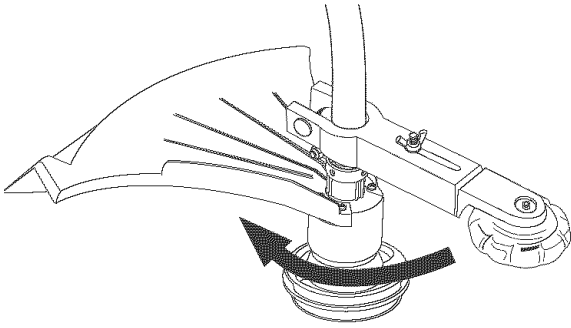

Fig. 15

6. Start the unit following the instructions described in *Starting/Stopping Instructions*.
7. Hold the shaft grip with your right hand and the D-handle with your left (Fig. 16).
8. Line up the cutting line with the edge of the sidewalk. The edge guide wheel will run parallel to the cutting line and roll a couple inches from the end of the sidewalk.
9. Squeeze the throttle control. The cutting attachment will trim the grass at the location where the two surfaces meet, producing a cleanly trimmed edge.
10. When you are done using the edger, move it out of the way. Loosen its wing nut and rotate the edger 180° from its position shown in Figure 15. The edger will rest above the cutting attachment guard. Re-tighten the wing nut and operate the trimmer normally. When you are finished, return to the trimming mode.



Fig. 16

USING THE EDGER AS A DEPTH GUIDE

The edge guide is also effective as a depth guide when trimming next to solid structures like walls, block fences or foundations (Fig. 17).

To adjust the guide's length, loosen the depth adjustment wing nut that is located on top of the guide (Fig. 17). Next, pull the guide out as far as it will go. This length is equal to the length of the trimming line. Tighten the wing nut.

Using the edge guide in this manner will greatly reduce line wear. Without it, trimming line will wear away more quickly as it repeatedly hits the structure you're trimming near.

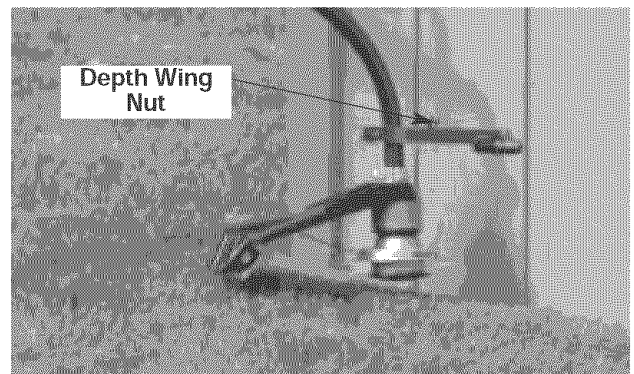

Fig. 17

MAINTENANCE AND REPAIR INSTRUCTIONS

MAINTENANCE SCHEDULE

Perform these required maintenance procedures at the frequency stated in the table. These procedures should also be a part of any seasonal tune-up.

NOTE: Some maintenance procedures may require special tools or skills. If you are unsure about these procedures, take your unit to a Sears or other qualified service dealer. Call 1-800-4-MY-HOME® for more information.

	<p>WARNING: To prevent serious injury, never perform maintenance or repairs with unit running. Always service and repair a cool unit. Disconnect the spark plug wire to ensure that the unit cannot start.</p>
---	---

NOTE: Maintenance, replacement, or repair of the emission control devices and system may be performed by a Sears or other qualified service dealer. Call 1-800-4-MY-HOME® for more information.

In order to assure peak performance of your engine, inspection of the engine exhaust port may be necessary after 50 hours of operation. If you notice lost RPM, poor performance or general lack of acceleration, this service may be required. If you feel your engine is in need of this inspection, refer service to a Sears or other qualified service dealer. Call 1-800-4-MY-HOME® for more information. **DO NOT** attempt to perform this process yourself as engine damage may result from contaminants involved in the cleaning process for the port.

FREQUENCY	MAINTENANCE REQUIRED	REFER TO
Before starting engine	Fill fuel tank with fresh fuel	Page 8
Every 10 hours	Clean and re-oil air filter	Page 14
Every 25 hours	Check and clean spark arrestor Check spark plug condition and gap	Page 15 Page 16
Every 50 hours	Inspect exhaust port and spark arrestor screen for clogging or obstruction to assure maximum performance levels	Page 15

MAINTENANCE AND REPAIR INSTRUCTIONS

AIR FILTER MAINTENANCE

Removing the Air Filter/Muffler Cover



WARNING: To avoid serious personal injury, always turn your unit off and allow it to cool before you clean or service it.

1. Remove the four (4) screws securing the air filter/muffler cover (Fig. 18). Use a flat blade or T20 Torx bit screwdriver.
2. Pull the cover from the engine. Do not force.

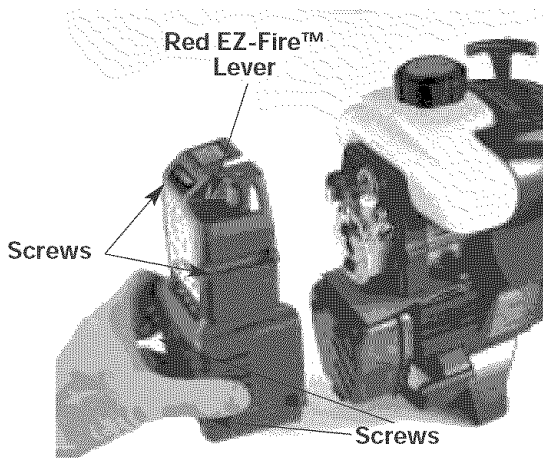

Fig. 18

Cleaning the Air Filter

Clean and re-oil the air filter every 10 hours of operation. It is an important item to maintain. Failure to maintain your air filter properly can result in poor performance or can cause permanent damage to your engine.

1. Remove air filter/muffler cover. Refer to *Removing the Air Filter/Muffler Cover*.
2. Turn cover over and look inside to locate the air filter. Remove the air filter from inside the air filter/muffler cover (Fig. 19).
3. Wash the filter in detergent and water (Fig. 20). Rinse the filter thoroughly. Squeeze out excess water. Allow it to dry completely.
4. Apply enough clean SAE 30 oil to lightly coat the filter (Fig. 21).
5. Squeeze the filter to spread and remove excess oil (Fig. 22).

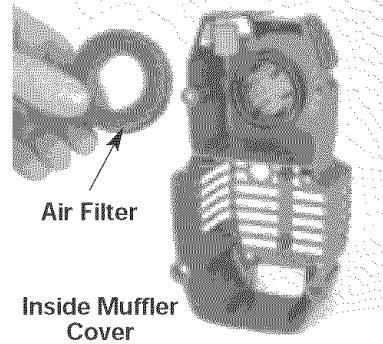

Fig. 19

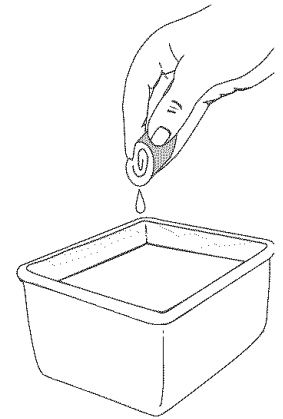

Fig. 20

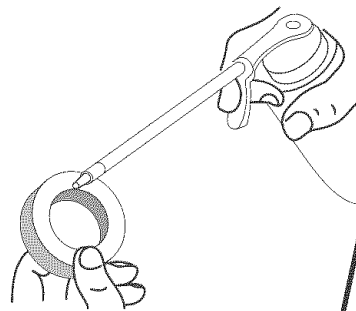

Fig. 21

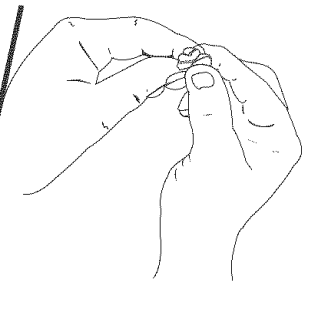

Fig. 22

6. Replace the air filter inside the air filter/muffler cover (Fig. 19).

NOTE: Operating the unit without the air filter and air filter/muffler cover assembly will VOID the warranty.

Reinstalling the Air Filter/Muffler Cover

1. Place the air filter/muffler cover over the back of the carburetor and muffler. Align the screw holes.
2. Insert the four (4) screws into the holes in the air filter/muffler cover (Fig. 18) and tighten.

Do not over tighten.

NOTE: Make sure the red EZ-Fire™ Lever is positioned away from the primer bulb.

MAINTENANCE AND REPAIR INSTRUCTIONS

SPARK ARRESTOR MAINTENANCE

NOTE: Please let engine cool. The exhaust can only flow in one direction: AWAY from the engine. Pay close attention when disassembling the muffler so you can put it back together correctly. Failure to do so will damage the unit and may cause serious personal injury.

1. Remove air filter/muffler cover. Refer to *Removing the Air Filter/Muffler Cover*.
2. Locate the muffler, but do not remove it. Find the two (2) screws on the bottom of the muffler (Fig. 23). These two screws hold the Spark Arrestor Hood Assembly and the spark arrestor screen to the bottom of the muffler. Remove the two (2) screws using either a Torx T20 or flat blade screwdriver.
3. Using a small flat blade screwdriver, carefully pry up the spark arrestor screen from the recessed hole, taking care to notice that the "raised" part of the spark arrestor screen is inside the recessed hole. Remove the spark arrestor screen from the muffler.
4. Clean the spark arrestor screen with a wire brush. Replace it if it is damaged, or if you are unable to clean it thoroughly.
5. Reinstall the spark arrestor screen by putting the "raised" portion of the screen inside the recessed hole of the muffler. Make sure that the spark arrestor screen fits flat against the muffler.
6. Place the spark arrestor plate on top of the spark arrestor screen with the raised side up and the opening facing toward the engine (Fig. 23).
7. Place the spark arrestor hood on top of the spark arrestor plate with the "raised" side up and the opening facing AWAY from the engine (Fig. 23). Verify that the exhaust will be directed AWAY from the engine.

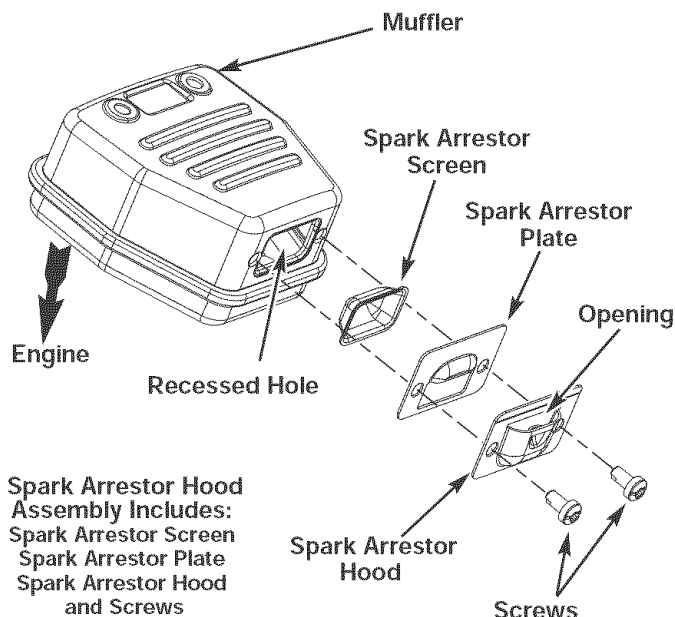

Fig. 23

8. Replace the two screws you removed in Step 2 and tighten them securely.
9. Reinstall the air filter/muffler cover (Fig. 18).



WARNING: If the exhaust deflector assembly is not tightened securely, it could fall off causing damage to the unit and possible serious personal injury.

CARBURETOR ADJUSTMENT

The idle speed of the engine is adjustable through the air filter/muffler cover (Fig. 24).

NOTE: Careless adjustments can seriously damage your unit. Contact a Sears or other qualified service dealer to make carburetor adjustments. Call 1-800-4-MY-HOME® for more information.

Check Fuel Mixture

Old and/or improperly mixed fuel is usually the reason for improper unit performance. Drain and refill the tank with fresh, properly-mixed fuel prior to making any adjustments. Refer to *Oil and Fuel Information*.

Clean Air Filter

The condition of the air filter is important to the operation of the unit. A dirty air filter will restrict air flow and change the air/fuel mixture. This is often mistaken for an out of adjustment carburetor. Check the condition of the air filter before adjusting the idle speed screw. Refer to *Air Filter Maintenance*.

Adjust Idle Speed Screw

If, after checking the fuel mixture and cleaning the air filter, the engine still will not idle, adjust the idle speed screw as follows:

1. Start the engine and let it run at a high idle for a minute to warm up. Refer to *Starting/Stopping Instructions*.



WARNING: The cutting attachment may spin during idle speed adjustments. Wear protective clothing and observe all safety instructions to prevent serious personal injury.

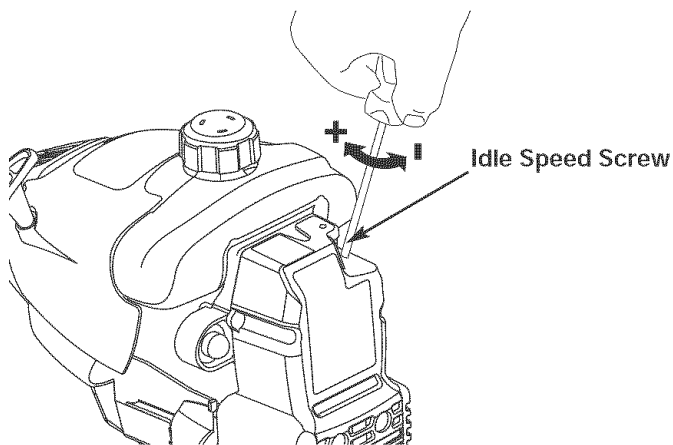

Fig. 24

MAINTENANCE AND REPAIR INSTRUCTIONS

2. Release the throttle trigger and let the engine idle. If the engine stops, insert a small phillips or flat blade screwdriver into the hole in the air filter/muffler cover (Fig. 24). Turn the idle speed screw in, **clockwise**, 1/8 of a turn at a time (as needed) until the engine idles smoothly.
3. If the engine appears to be idling too fast, turn the idle speed screw **counterclockwise** 1/8 of a turn at a time (as needed), to reduce idle speed.

Checking the fuel mixture, cleaning the air filter, and adjusting the idle speed should solve most engine problems. If not and all of the following are true:

- the engine will not idle
- the engine hesitates or stalls on acceleration
- there is a loss of engine power

Have the carburetor adjusted by a Sears or other qualified service dealer. Call 1-800-4-MY-HOME® for more information.

REPLACING THE SPARK PLUG

Use a Champion RDJ7Y spark plug, or equivalent. The correct air gap is **0.020 inch (0.5 mm)**. Remove the plug after every 25 hours of operation and check its condition.

1. Stop the engine and allow it to cool. Grasp the plug wire firmly and pull it from the spark plug.
2. Clean around the spark plug. Remove the spark plug from the cylinder head by turning a 5/8-inch socket counterclockwise.
3. Replace a cracked, fouled or dirty spark plug. Set the air gap at **0.020 in. (0.5 mm)** using a feeler gauge (Fig. 25).



WARNING: Do not sand blast, scrape or clean electrodes. Grit in the engine could damage the cylinder.

4. Install a correctly-gapped spark plug in the cylinder head. Tighten by turning the 5/8-inch socket clockwise until snug.

If using a torque wrench torque to **110-120 in. •lb. (12.3-13.5 N•m)**. **Do not over tighten.**

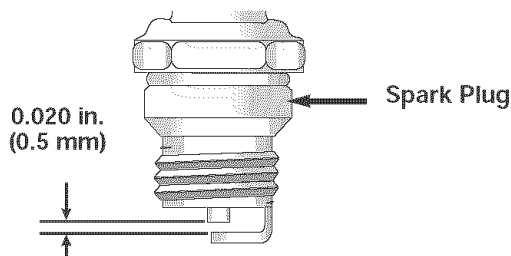

Fig. 25

TRANSPORTING

- Allow the engine to cool before transporting.
- Drain fuel from unit.
- Tighten fuel cap before transporting.
- Secure the unit while transporting.

CLEANING



WARNING: To avoid serious personal injury, always turn your trimmer off and allow it to cool before you clean or maintain it.

Use a small brush to clean off the outside of the unit. Do not use strong detergents. Household cleaners that contain aromatic oils such as pine and lemon, and solvents such as kerosene, can damage plastic housing or handle. Wipe off any moisture with a soft cloth.

STORAGE

- Never store a fueled unit where fumes may reach an open flame or spark.
- Allow the engine to cool before storing.
- Store the unit locked up to prevent unauthorized use or damage.
- Store the unit in a dry, well-ventilated area.
- Store the unit out of the reach of children.

LONG TERM STORAGE

If you plan on storing the unit for an extended time, use the following storage procedure:

1. Carefully drain the fuel tank by running the unit dry or remove fuel cap and tip the motor housing over and drain oil/gas fuel into a container with the same 2-cycle fuel mixture. Do not use fuel that has been stored for more than 60 days.



CAUTION: Dispose of the old fuel/oil mixture in accordance with all Federal, State, and Local regulations.

2. Start the engine and allow it to run until it stalls. This ensures that all fuel has been drained from the carburetor.
3. Allow the engine to cool. Remove the spark plug and put 1 oz. (30 ml) of any high quality motor oil or 2-cycle oil into the cylinder. Pull the starter rope slowly to distribute the oil. Reinstall the spark plug.

NOTE: Remove the spark plug and drain all of the oil from the cylinder before attempting to start the trimmer after storage.



CAUTION: Dispose of the old oil in accordance with all Federal, State, and Local regulations.

4. Thoroughly clean the unit and inspect it for any loose or damaged parts. Repair or replace damaged parts and tighten loose screws, nuts or bolts. The unit is ready for storage.

TROUBLESHOOTING

ENGINE WILL NOT START

CAUSE

1. Empty fuel tank
2. Primer bulb wasn't pressed enough
3. Engine is flooded
4. Old or improperly mixed fuel
5. Fouled spark plug
6. Plugged spark arrestor
7. Red EZ-Fire™ lever wasn't flipped/set
8. The outside temperature is below 40° F
9. The outside temperature is above 90° F

ACTION

1. Fill fuel tank with properly mixed fuel
2. Press primer bulb fully and slowly 10 times
3. Squeeze the trigger and pull the starter rope
4. Drain gas tank and add fresh fuel mixture
5. Replace or clean the spark plug
6. Clean or replace spark arrestor
7. Move lever to the starting position
8. Pull the starter rope up to 10-15 times
9. Squeeze the throttle control and pull the starter rope without moving the Red EZ-Fire™ lever

ENGINE WILL NOT IDLE

CAUSE

1. Air filter is plugged
2. Old or improperly mixed fuel
3. Improper carburetor adjustment

ACTION

1. Replace or clean the air filter
2. Drain gas tank and add fresh fuel mixture
3. Adjust according to the *Carburetor Adjustments*

ENGINE WILL NOT ACCELERATE

CAUSE

1. Old or improperly mixed fuel
2. Improper carburetor adjustment
3. Cutting attachment bound with grass
4. Dirty air filter
5. Plugged spark arrestor

ACTION

1. Drain gas tank and add fresh fuel mixture
2. Take to a Sears or other qualified service dealer for an adjustment
3. Stop the engine and clean the cutting attachment
4. Clean or replace the air filter
5. Clean or replace spark arrestor

ENGINE LACKS POWER OR STALLS WHEN CUTTING

CAUSE

1. Old or improperly mixed fuel
2. Air filter is plugged
3. Improper carburetor adjustment
4. Fouled spark plug
5. Plugged spark arrestor

ACTION

1. Drain gas tank and add fresh fuel mixture
2. Replace or clean air filter
3. Take to a Sears or other qualified service dealer for an adjustment
4. Replace or clean the spark plug
5. Clean or replace spark arrestor

NOTE: For repairs beyond the minor adjustments listed above, contact your nearest Sears Parts & Repair center (1-800-4-MY-HOME®) or other qualified service dealer for an adjustment.

SPECIFICATIONS

ENGINE*

Engine Type.....	Air-Cooled, 2-Cycle
Displacement.....	31.5 cc (1.95 cu in.)
Idle Speed RPM.....	2,800 - 3,600 rpm
Operating RPM.....	7,200+ rpm
Ignition Type.....	Electronic-MAX FIRE IGNITION™
Ignition Switch.....	Rocker Switch
Spark Plug Gap.....	0.020 in. (0.5 mm)
Lubrication.....	Fuel/Oil Mixture
Fuel/Oil Ratio.....	40:1
Carburetor.....	Diaphragm, All-Position
Starter.....	Incredi-Pull™ Starting Auto Rewind
Muffler.....	Baffled with Guard
Throttle.....	Manual Spring Return
Fuel Tank Capacity.....	13 oz. (384 ml)

DRIVE SHAFT & CUTTING ATTACHMENT*

Drive Shaft Housing.....	Steel Tube (Twist and Edge™)
Throttle Control.....	Finger-Tip Trigger
Approximate Unit Weight (No fuel, with cutting attachment, shield, edge guide and D-handle).....	13.5 lbs. (6 kg)
Cutting Mechanism.....	Hassle-Free III™ Head
Trimming Line Diameter.....	Hassle Free III™ XTRA QUIET Spiral Line
Cutting Path Diameter.....	14 inches (35.56 cm)

*All specifications are based on the latest product information available at the time of printing. We reserve the right to make changes at any time without notice.

PARTS LIST

ENGINE PARTS - MODEL 791810 2-CYCLE GAS TRIMMER

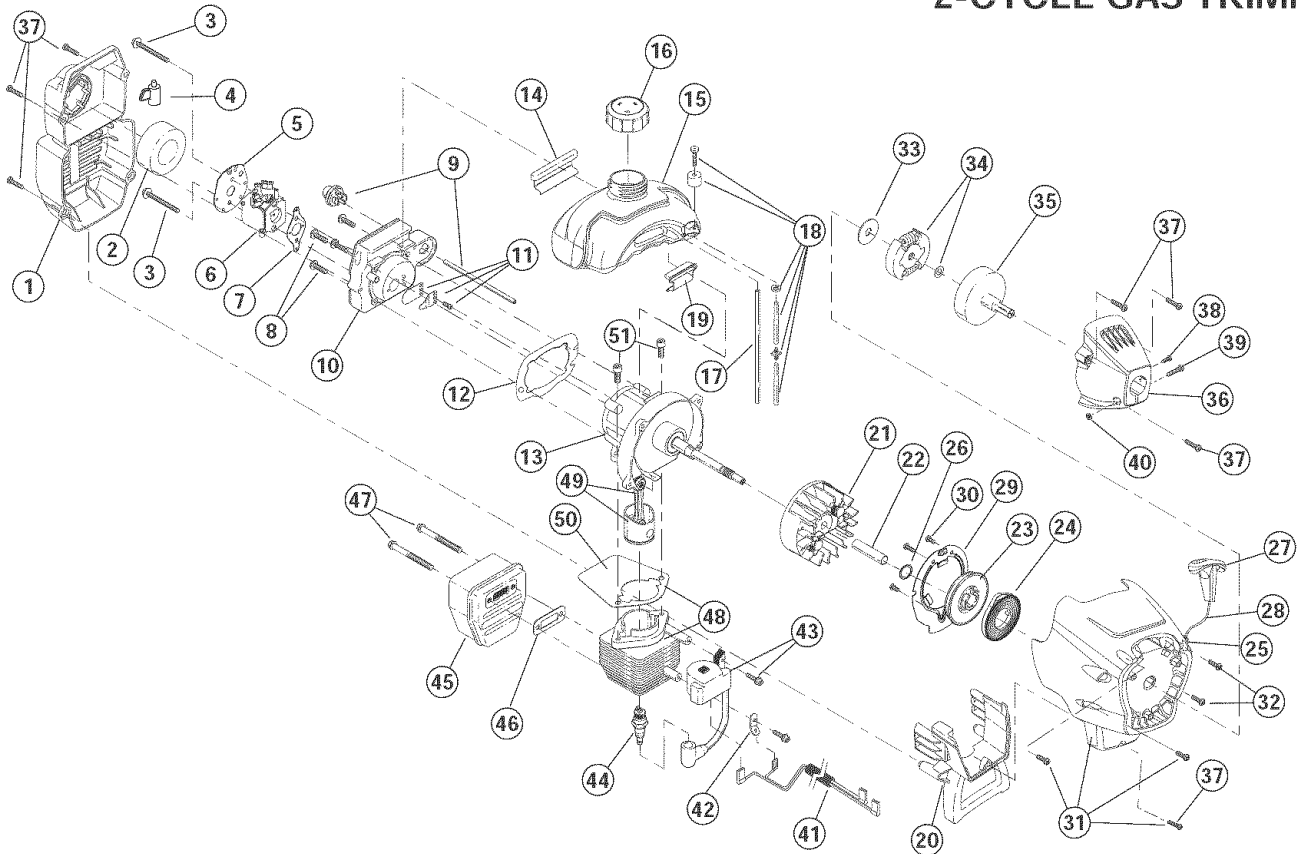

Item	Part No.	Description	Item	Part No.	Description
1	753-04810	Air Cleaner Assembly (includes 2 & 37)	31	753-05049	Starter Housing Assembly (includes 23-30, 32 & 37)
2	791-180350B	Air Cleaner Filter	32	791-181862	Housing Screw
3	791-180351	Carburetor Mounting Screw Assembly	33	791-182396	Clutch Washer
4	753-04227	Choke Extension	34	791-182369	Clutch Rotor Assembly
5	753-1194	Choke Plate	35	791-153592	Clutch Drum Assembly
6	753-04338	Carburetor Assembly (includes 7 & 18)	36	753-04497	Clutch Cover Assembly (includes 37-40)
7	791-610675	Carburetor Gasket	37	791-181345	Cover Screw
8	791-181860	Carb Mount Screw	38	791-182519	Anti-Rotation Screw
9	791-683974B	Primer and Hose Assembly	39	753-04003	Clamping Screw
10	753-1196	Carb Mount Assembly (includes 8, 11 & 12)	40	791-180217	Clamping Nut
11	791-684451	Reed Assembly	41	753-04792	Wire Leads and Sleeve
12	753-1208	Carburetor Mount Gasket	42	791-611063	Ground Tab
13	753-04401	Crank Case Service Assembly (includes 8)	43	753-05012	Module Assembly (includes 42)
14	791-612134	Rear Mounting Pad	44	791-610311B	Spark Plug
15	753-04606	Fuel Tank Assembly (includes 16-18)	45	753-04618	Muffler Assembly (includes 46 & 47)
16	791-181803	Fuel Cap Assembly	46	753-04619	Exhaust Gasket
17	791-181086	Fuel Return Line	47	753-04620	Muffler Mounting Bolt Assembly
18	791-683398	Fuel Line Assembly	48	753-04814	Cylinder Assembly (includes 50 & 51)
19	791-145308	Front Mounting Pad	49	753-04367	Piston and Rod Assembly
20	753-04702	Shroud Extension & Stand (includes 37)	50	753-04182	Cylinder Gasket
21	791-182736	Flywheel Assembly	51	791-182723	Cylinder Bolt
22	791-181525	Spacer	*	753-04689	Spark Arrestor
23	753-04459	Recoil Pulley Assembly (includes 26)	*	753-1209	Piston Ring Set
24	753-04286	Recoil Spring	*	753-04812	Short Block Assembly (includes 13, 44 & 48-51)
25	753-1200	Rope Guide	*	791-181599	Clutch Springs (Qty. 2)
26	753-04288	Palnut			
27	753-05011	Pull Handle			
28	791-613103	Rope			
29	753-04417	Pressure Plate Assembly (includes 30)			
30	753-1202	Plate Screw			
			*		Items Not Shown

PARTS LIST

BOOM & TRIMMER PARTS - MODEL 791810 2-CYCLE GAS TRIMMER

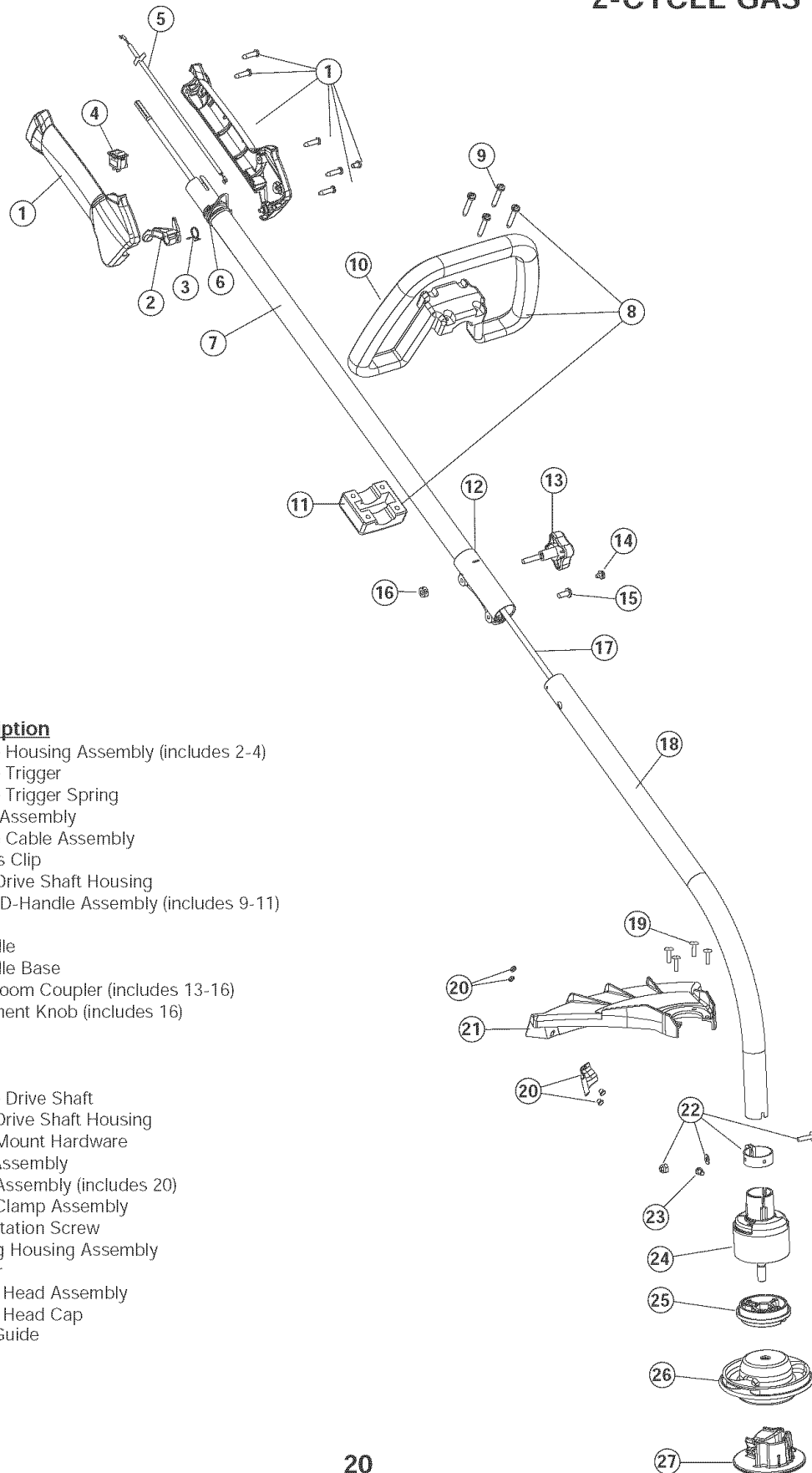

Item	Part No.	Description
1	753-04234	Throttle Housing Assembly (includes 2-4)
2	753-04119	Throttle Trigger
3	791-182690	Throttle Trigger Spring
4	791-182405	Switch Assembly
5	753-04405	Throttle Cable Assembly
6	791-610327	Harness Clip
7	753-05022	Upper Drive Shaft Housing
8	791-180869	Deluxe D-Handle Assembly (includes 9-11)
9	791-181070	Screw
10	791-182167	D-Handle
11	791-182168	D-Handle Base
12	753-05029	Twist Boom Coupler (includes 13-16)
13	791-181981	Adjustment Knob (includes 16)
14	791-182057	Screw
15	791-181617	Bolt
16	753-04386	Nut
17	753-05030	Flexible Drive Shaft
18	753-05031	Lower Drive Shaft Housing
19	791-180531	Shield Mount Hardware
20	753-05033	Blade Assembly
21	753-05032	Shield Assembly (includes 20)
22	791-153597	Lower Clamp Assembly
23	791-145569	Anti-Rotation Screw
24	753-05050	Bushing Housing Assembly
25	753-05034	Adapter
26	753-05035	Cutting Head Assembly
26	753-05036	Cutting Head Cap
*	753-05039	Edger Guide

* Items Not Shown

NOTES

California / EPA Emission Control Warranty Statement

Your Warranty Rights and Obligations

The California Air Resources Board, The Environmental Protection Agency and Sears are pleased to explain the emission control system warranty on your 2000 and later small off-road engine. New small off-road engines must be designed, built and equipped to meet stringent anti-smog standards. SEARS must warrant the emission control system on your small off-road engine for the periods of time listed below provided there has been no abuse, neglect or improper maintenance of your small off-road engine.

Your Emission control system may include parts such as the carburetor or fuel-injection system, the ignition system, and catalytic converter. Also included may be hoses, belts, connectors and other emission-related assemblies.

Where a warrantable condition exists, Sears will repair your small off-road engine at no cost to you including diagnosis, parts and labor.

The 2000 and later small off-road engines are warranted for two years. If any emission-related part on your engine is defective, the part will be repaired or replaced by Sears.

Owner's Warranty Responsibilities

- As the small off-road engine owner, you are responsible for the performance of the required maintenance listed in your operator's manual. Sears recommends that you retain all receipts covering maintenance on your small off-road engine, but Sears cannot deny warranty solely for the lack of receipts or for your failure to ensure the performance of all scheduled maintenance.
- As the small off-road engine owner, you should however be aware that Sears may deny you warranty coverage if your small off-road engine or a part has failed due to abuse, neglect, improper maintenance or unapproved modifications.
- You are responsible for presenting your small off-road engine to a Sears authorized service center as soon as problem exists. The warranty repairs should be completed in a reasonable amount of time, not to exceed 30 days.

If you have any questions regarding your warranty rights and responsibilities, you should call 1-800-4-MY-HOME®.

Manufacturer's Warranty Coverage

- The warranty period begins on the date the engine or equipment is delivered to the retail purchaser.
- The manufacturer warrants to the initial owner and each subsequent purchaser, that the engine is free from defects in material and workmanship which cause the failure of a warranted part for a period of two years.
- Repair and replacement of warranted part will be performed at no charge to the owner at an authorized Sears service center. For the nearest location please contact Sears at: 1-800-4-MY-HOME®.
- Any warranted part which is not scheduled for replacement, as required maintenance or which is scheduled only for regular inspection to the effect of "Repair or Replace as Necessary" is warranted for the period. Any warranted part which is scheduled for replacement as required maintenance will be warranted for the period of time up to the first scheduled replacement point for that part.
- The owner will not be charged for diagnostic labor which leads to the determination that a warranted part is defective, if the diagnostic work is performed at an authorized Sears Service Center.
- The manufacturer is liable for damages to other engine components caused by the failure of a warranted part still under warranty.
- Failures caused by abuse, neglect or improper maintenance are not covered under warranty.
- The use of add-on or modified parts can be grounds for disallowing a warranty claim. The manufacturer is not liable to cover failures of warranted parts caused by the use of add-on or modified parts.
- In order to file a claim, go to your nearest authorized Sears Service Center. Warranty service or repairs will be provided at all authorized Sears Service Centers.
- Any manufacturer approved replacement part may be used in the performance of any warranty maintenance or repair of emission related parts and will be provided without charge to the owner. Any replacement part that is equivalent in performance or durability may be used in non-warranty maintenance or repair and will not reduce the warranty obligations of the manufacturer.
- The following components are included in the emission related warranty: engine, air filter, carburetor, primer, fuel lines, fuel pick up/fuel filter, ignition module, spark plug and muffler.

Repair Protection Agreements

Congratulations on making a smart purchase. Your new Craftsman® product is designed and manufactured for years of dependable operation. But like all products, it may require repair from time to time. That's when having a Repair Protection Agreement can save you money and aggravation.

Purchase a Repair Protection Agreement now and protect yourself from unexpected hassle and expense.

Here's what's included in the Agreement:

- ☑ **Expert service** by our 12,000 professional repair specialists
- ☑ **Unlimited service and no charge** for parts and labor on all covered repairs
- ☑ **Product replacement** if your covered product can't be fixed
- ☑ **Discount of 10%** from regular price of service and service-related parts not covered by the agreement; also, 10% off regular price of preventive maintenance check
- ☑ **Fast help by phone** – phone support from a Sears technician on products requiring in-home repair, plus convenient repair scheduling

Once you purchase the Agreement, a simple phone call is all that it takes for you to schedule service. You can call anytime day or night, or schedule a service appointment online.

Sears has over 12,000 professional repair specialists, who have access to over 4.5 million quality parts and accessories. That's the kind of professionalism you can count on to help prolong the life of your new purchase for years to come. Purchase your Repair Protection Agreement today!

Some limitations and exclusions apply.
For prices and additional information call 1-800-827-6655.

Sears Installation Service

For Sears professional installation of home appliances, garage door openers, water heaters, and other major home items, in the U.S.A. call 1-800-4-MY-HOME®

Get it fixed, at your home or ours!

Your Home

For repair – **in your home** – of **all** major brand appliances, lawn and garden equipment, or heating and cooling systems, **no matter who made it, no matter who sold it!**

For the replacement parts, accessories and owner's manuals that you need to do-it-yourself.

For Sears professional installation of home appliances and items like garage door openers and water heaters.

1-800-4-MY-HOME® (1-800-469-4663)

Call anytime, day or night (U.S.A. and Canada)

www.sears.com www.sears.ca

Our Home

For repair of carry-in items like vacuums, lawn equipment, and electronics, call or go on-line for the location of your nearest

Sears Parts & Repair Center.

1-800-488-1222

Call anytime, day or night (U.S.A. only)

www.sears.com

To purchase a protection agreement (U.S.A.) or maintenance agreement (Canada) on a product serviced by Sears:

1-800-827-6655 (U.S.A.)

1-800-361-6665 (Canada)

Para pedir servicio de reparación a domicilio, y para ordenar piezas:

1-888-SU-HOGARSM

(1-888-784-6427)

Au Canada pour service en français:

1-800-LE-FOYER^{MC}

(1-800-533-6937)

www.sears.ca

