

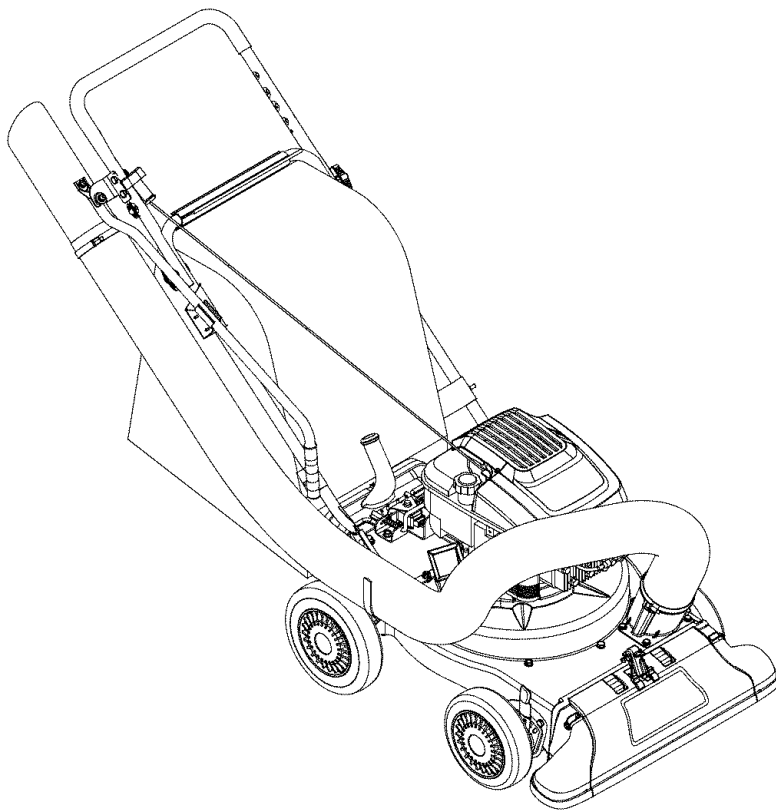

# Operator's Manual



**Yard Vacuum  
Chipper/Shredder/  
Vacuum/Hose**  
Model Number  
24B-060F766

## **IMPORTANT: READ SAFETY RULES AND INSTRUCTIONS CAREFULLY**

**Warning:** This unit is equipped with an internal combustion engine and should not be used on or near any unimproved forest-covered, brush-covered or grass-covered land unless the engine's exhaust system is equipped with a spark arrester meeting applicable local or state laws (if any). If a spark arrester is used, it should be maintained in effective working order by the operator. In the State of California the above is required by law (Section 4442 of the California Public Resources Code). Other states may have similar laws. Federal laws apply on federal lands. A spark arrester for the muffler is available through your nearest engine authorized service dealer or contact the service department, P.O. Box 361131 Cleveland, Ohio 44136-0019.

**TROY-BILT LLC P.O. BOX 361131 CLEVELAND, OHIO 44136-0019**

PRINTED IN U.S.A.

FORM NO. 769-00835A  
(5/04)

## TABLE OF CONTENTS

Content	Page	Content	Page
Important Safe Operation Practices	3	Maintaining Your Yard Vacuum	10
Assembling Your Yard Vacuum	5	Trouble Shooting	13
Know Your Yard Vacuum	7	Illustrated Parts List	14
Operating Your Yard Vacuum	8	Warranty	20

## FINDING MODEL NUMBER

This Operator's Manual is an important part of your new Yard Vacuum. It will help you assemble, prepare and maintain the unit for best performance. Please read and understand what it says.



**Before you start assembling your new equipment**, please locate the model plate on the equipment and copy the information from it in the space provided below. A sample model plate is also given below. You can locate the model plate by looking down at the rear of the Yard Vacuum. This information will be necessary to use the manufacturer's web site and/or help from the Customer Support Department or an authorized service dealer.



Copy the model number here: \_\_\_\_\_

Copy the serial number here: \_\_\_\_\_

## CUSTOMER SUPPORT

**Please do NOT return the unit to the retailer from where it was purchased, without first contacting Customer Support.**

If you have difficulty assembling this product or have any questions regarding the controls, operation or maintenance of this unit, you can seek help from the experts. Choose from the options below:

	<p>Visit <b>troybilt.com</b> for many useful suggestions. Click on Customer Support button and you will get the four options reproduced here. Click on the appropriate button and help is immediately available.</p> <div style="display: flex; justify-content: space-between; align-items: center;"> <div style="width: 45%; text-align: center;"> <p><i>The answer you are looking for could be just a mouse click away!</i></p> </div> <div style="width: 10%; text-align: center;"> </div> <div style="width: 45%; text-align: center;"> <p><i>The answer you are looking for could be just a mouse click away!</i></p> </div> </div>
	<p>If you prefer to reach a Customer Support Representative, please call <b>1-800-520-5520</b>.</p>
	<p>The <b>engine</b> manufacturer is responsible for all engine-related issues with regards to performance, power-rating, specifications, warranty and service. Please refer to the engine manufacturer's Owner's/Operator's Manual, packed separately with your unit, for more information.</p>

---

## SECTION 1: IMPORTANT SAFE OPERATION PRACTICES



**WARNING:** This symbol points out important safety instructions which, if not followed, could endanger the personal safety and/or property of yourself and others. Read and follow all instructions in this manual before attempting to operate this machine. Failure to comply with these instructions may result in personal injury. When you see this symbol - **heed its warning**.



**WARNING:** Engine Exhaust, some of its constituents, and certain vehicle components contain or emit chemicals known to State of California to cause cancer and birth defects or other reproductive harm.

**DANGER:** This machine was built to be operated according to the rules for safe operation in this manual. As with any type of power equipment, carelessness or error on the part of the operator can result in serious injury. This machine is capable of amputating hands and feet and throwing objects. Failure to observe the following safety instructions could result in serious injury or death.

### TRAINING

1. Read, understand, and follow all instructions on the machine and in the manual(s) before attempting to assemble and operate. Keep this manual in a safe place for future and regular reference and for ordering replacement parts.
  2. Be familiar with all controls and their proper operation. Know how to stop the machine and disengage them quickly.
  3. Never allow children under 16 years old to operate this machine. Children 16 years old and over should read and understand the operation instructions and safety rules in this manual and should be trained and supervised by a parent.
  4. Never allow adults to operate this machine without proper instruction.
  5. Keep bystanders, helpers, pets, and children at least 75 feet from the machine while it is in operation. Stop machine if anyone enters the area.
  6. Never run an engine indoors or in a poorly ventilated area. Engine exhaust contains carbon monoxide, an odorless and deadly gas.
  7. Do not put hands and feet near rotating parts or in the feeding chambers and discharge opening. Contact with the rotating impeller can amputate fingers, hands, and feet.
  8. Never attempt to unclog either the feed intake or discharge opening, remove or empty vacuum bag, or inspect and repair the machine while the engine is running. Shut the engine off and wait until all moving parts have come to a complete stop. Disconnect the spark plug wire and ground it against the engine.
2. Always wear safety glasses or safety goggles during operation or while performing an adjustment or repair, to protect eyes. Thrown objects which ricochet can cause serious injury to the eyes.
  3. Wear sturdy, rough-soled work shoes and close-fitting slacks and shirts. Loose fitting clothes or jewelry can be caught in movable parts. Never operate this machine in bare feet or sandals. Wear leather work gloves when feeding material in the chipper chute.
  4. Before starting, check all bolts and screws for proper tightness to be sure the machine is in safe working condition. Also, visually inspect machine for any damage at frequent intervals.
  5. Maintain or replace safety and instructions labels, as necessary.
  6. To avoid personal injury or property damage use extreme care in handling gasoline. Gasoline is extremely flammable and the vapors are explosive. Serious personal injury can occur when gasoline is spilled on yourself or your clothes which can ignite. Wash your skin and change clothes immediately.
    - a. Use only an approved gasoline container.
    - b. Extinguish all cigarettes, cigars, pipes, and other sources of ignition.
    - c. Never fuel machine indoors.
    - d. Never remove gas cap or add fuel while the engine is hot or running.
    - e. Allow engine to cool at least two minutes before refueling.
    - f. Never over fill fuel tank. Fill tank to no more than 1/2 inch below bottom of filler neck to provide space for fuel expansion.
    - g. Replace gasoline cap and tighten securely.
    - h. If gasoline is spilled, wipe it off the engine and equipment. Move machine to another area. Wait 5 minutes before starting the engine.

### PREPARATION

1. Thoroughly inspect the area where the equipment is to be used. Remove all rocks, bottles, cans, or other foreign objects which could be picked up or thrown and cause personal injury or damage to the machine.

- i. Never store the machine or fuel container inside where there is an open flame, spark, or pilot light (e.g. furnace, water heater, space heater, clothes dryer, etc.)
- j. To reduce a fire hazard, keep machine free of grass, leaves, or other debris build-up. Clean up oil or fuel spillage and remove any fuel soaked debris.
- k. Allow machine to cool at least 5 minutes before storing.

## OPERATION

1. Do not put hands and feet near rotating parts or in the feeding chambers and discharge opening. Contact with the rotating impeller can amputate fingers, hands, and feet.
2. Before starting the machine, make sure the chipper chute, feed intake, and cutting chamber are empty and free of all debris.
3. Thoroughly inspect all material to be shredded and remove any metal, rocks, bottles, cans, or other foreign objects which could cause personal injury or damage to the machine.
4. If the impeller strikes a foreign object or if your machine should start making an unusual noise or vibration, immediately shut the engine off. Allow the impeller to come to a complete stop. Disconnect the spark plug wire, ground it against the engine and perform the following steps:
  - a. Inspect for damage.
  - b. Repair or replace any damaged parts.
  - c. Check for any loose parts and tighten to assure continued safe operation.
5. Do not allow an accumulation of processed material to build up in the discharge area. This can prevent proper discharge and result in kickback of material through the feed opening.
6. Do not attempt to shred or chip material larger than specified on the machine or in this manual. Personal injury or machine damage could result.
7. Never attempt to unclog either the feed intake or discharge opening while the engine is running. Shut the engine off, wait until all moving parts have stopped, disconnect the spark plug wire and ground it against the engine before clearing debris.
8. Never operate without vacuum bag and discharge chute properly attached to the machine. Never empty or change vacuum bag while the engine is running. Zippered end of vacuum bag must be kept closed at all times during operation.

9. Never operate without either the inlet nozzle or optional hose attachment properly attached to the machine. Never attempt to attach or change either attachment while the engine is running.
10. Keep all guards, deflectors and safety devices in place and operating properly.
11. Keep your face and body back and to the side of the chipper chute while feeding material into the machine to avoid accidental kickback injuries.
12. Never operate this machine without good visibility or light. Always be sure of your footing and keep a firm hold on the handles.
13. Do not operate this machine on a gravel surface.
14. Do not operate this machine while under the influence of alcohol or drugs.
15. Muffler and engine become hot and can cause a burn. Do not touch.
16. Never pick up or carry machine while the engine is running.

## MAINTENANCE AND STORAGE

1. Never tamper with safety devices. Check their proper operation regularly.
2. Check bolts and screws for proper tightness at frequent intervals to keep the machine in safe working condition. Also, visually inspect machine for any damage and repair, if needed.
3. Before cleaning, repairing, or inspecting, stop the engine and make certain the impeller and all moving parts have stopped. Disconnect the spark plug wire and ground it against the engine to prevent unintended starting.
4. Do not change the engine governor settings or overspeed the engine. The governor controls the maximum safe operating speed of the engine.
5. Maintain or replace safety and instruction labels, as necessary.
6. Follow this manual for safe loading, unloading, transporting, and storage of this machine.
7. Never store the machine or fuel container inside where there is an open flame, spark or pilot light such as a water heater, furnace, clothes dryer, etc.
8. Always refer to the operator's manual for proper instructions on off-season storage.
9. If the fuel tank has to be drained, do this outdoors.
10. Observe proper disposal laws and regulations for gas, oil, etc. to protect the environment.



**WARNING - YOUR RESPONSIBILITY:** Restrict the use of this power machine to persons who read, understand and follow the warnings and instructions in this manual and on the machine.

**NOTE:** Not all safety labels may apply to your Yard Vacuum.

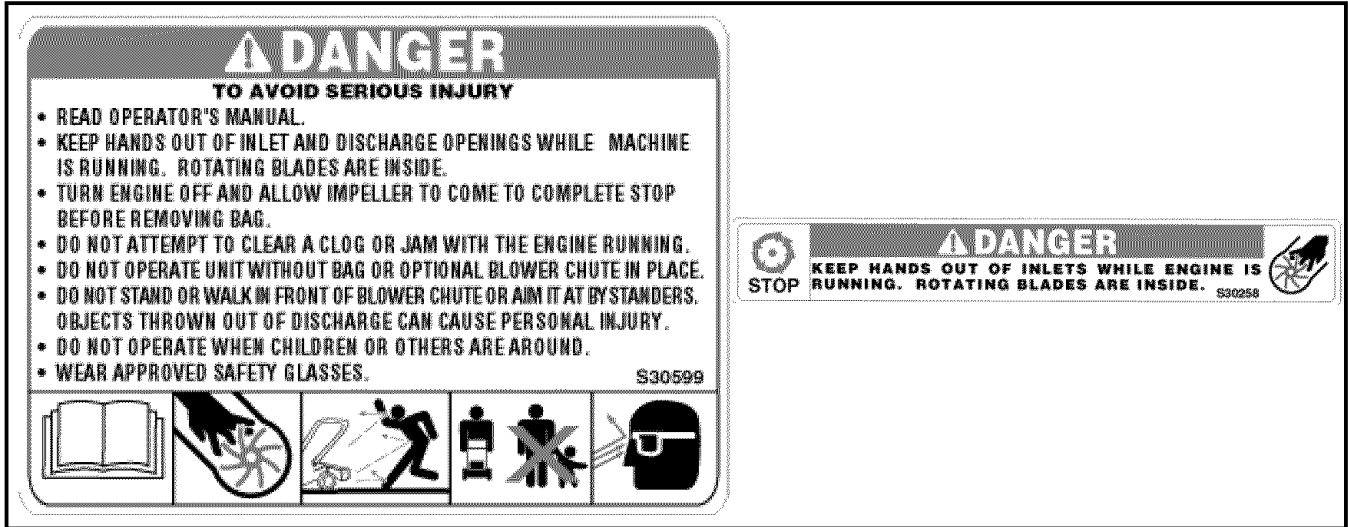

## SECTION 2: ASSEMBLING YOUR YARD VACUUM

**IMPORTANT:** This unit is shipped without gasoline or oil in the engine. Be certain to service engine with gasoline and oil as instructed in the separate engine manual before operating your machine.

**NOTE:** Reference to right or left hand side of the Yard Vacuum is observed from the operating position.

### Removing Unit From Carton

- Remove staples, break glue on top flaps, or cut tape at carton end and peel along top flap to open carton.
- Remove loose parts if included with unit (i.e., operator's manual, etc.)
- Cut along corners, lay carton down flat, and remove packing material.
- Roll or slide unit out of carton and check carton thoroughly for loose parts.

### Loose Parts In Carton (See Figure 1)

- Handle Assembly
- Bag
- Blower Chute (If Equipped)
- Hose Assembly

### Disconnecting Spark Plug Wire

Before setting up your Yard Vacuum, disconnect the spark plug wire from the spark plug and ground to a stud on the engine.

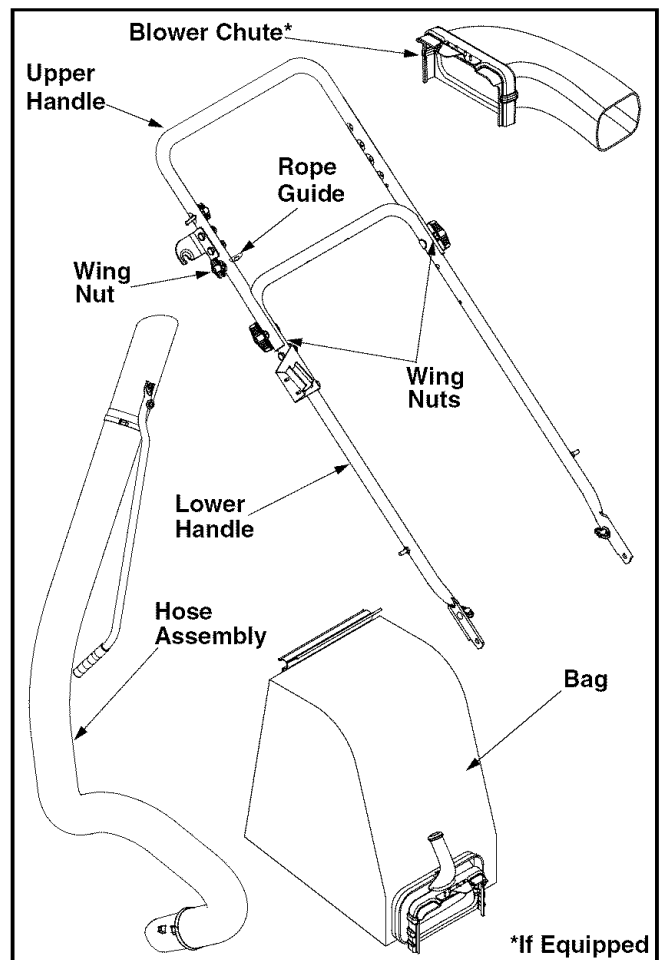

Figure 1

## Attaching The Handle

- Unfold the upper handle until it aligns with the lower handle.
- Secure the two handles by tightening the wing nuts (carriage bolts must be seated properly into the handle). See Figure 1.
- Remove the hairpin clips from the handle brackets on the Yard Vacuum and remove the carriage bolts and wing nuts from the lower handle. See Figure 2.
- Place the bottom holes in lower handle over pins on handle brackets and secure with hairpin clips.
- Insert carriage bolts through upper hole in lower handle from the outside and secure with wing nuts.

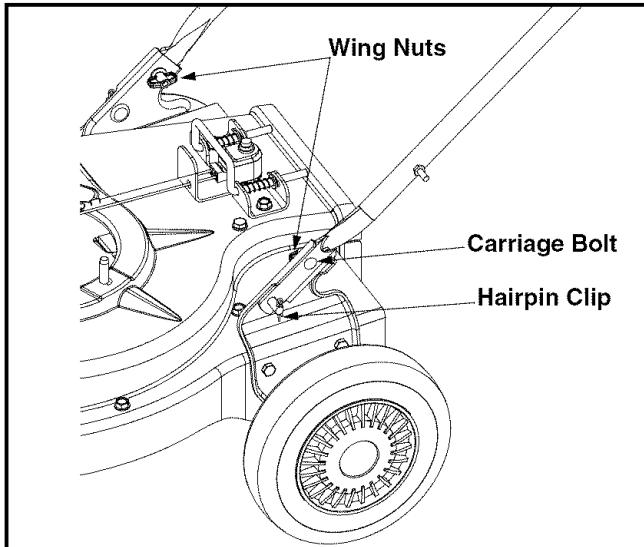

Figure 2

- Loosen the wing nut that secures the rope guide to the right side of upper handle.
- Pull the starter rope out of the engine slowly and slip the starter rope into the rope guide. Tighten the wing nut.

## Attaching The Hose Assembly

- Slide hose adapter of hose assembly into the base adapter located on the left front of the Yard Vacuum. See Figure 3.
- Pull spring loaded pin out on the base and align pin with the first hole in the hose adapter.
- Release the pin to lock the hose in place.
- Connect the hose handle near nozzle end of hose to the handle bracket on the upper handle. Refer to Figure 6.
- Snap hose handle into the nozzle handle clip on the lower handle to secure in place and lay hose tubing on side hanger bracket next to chipper chute. Refer to Figure 6.

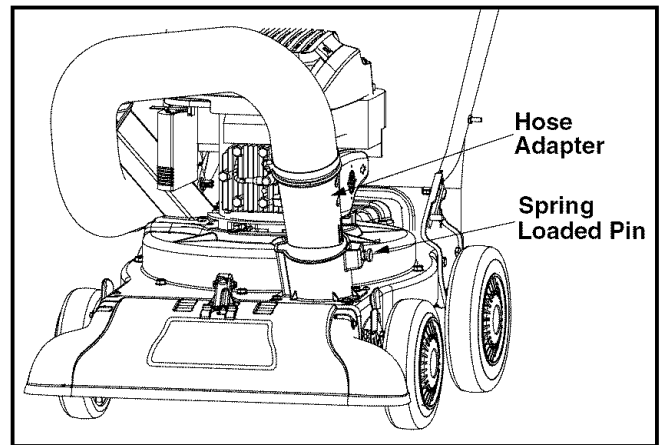

Figure 3

## Attaching The Bag

- Grasp bag handle with one hand and slide locking rod on mounting bracket with other hand toward engine. Use the end of mounting bracket as leverage when sliding the locking rod. See Figure 4.
- Slip bag over the rim of the discharge opening and release locking rod to secure bag in place.
- Place the straps on the bag **over** the lower handle, hooking them on the studs.
- Snap bag clip to the top of the lower handle.

**NOTE:** The safety switch button attached to the mounting bracket must be fully depressed by the front tab on the bag handle when securing the bag or the engine will not start. See Figure 4.

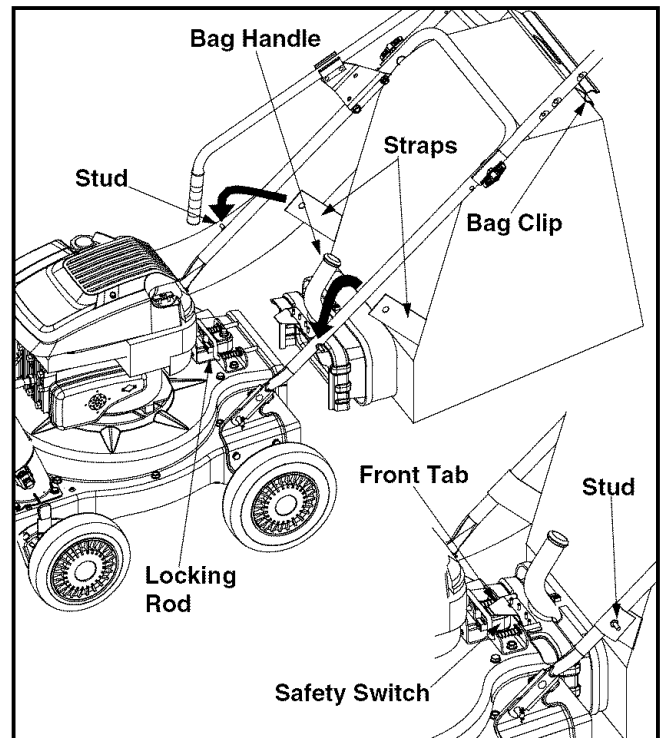

Figure 4

## Attaching The Blower Chute (If Equipped)

**NOTE:** The blower chute is an optional feature on some model yard vacuums. It is NOT standard equipment. If your unit is not equipped with a blower chute, contact Customer Support as instructed on page 2 for information regarding price and availability.

- Grasp blower chute with one hand and slide locking rod on mounting bracket with other hand toward engine. Use end of mounting bracket as leverage when sliding the locking rod. See Figure 5.
- Slip blower chute over rim of the discharge opening and release locking rod to secure chute in place. Make sure the safety switch button is fully depressed by the front tab on the blower chute.
- Raise the nozzle height to the highest setting when using the blower chute. Refer to nozzle height adjustment in the OPERATION section.

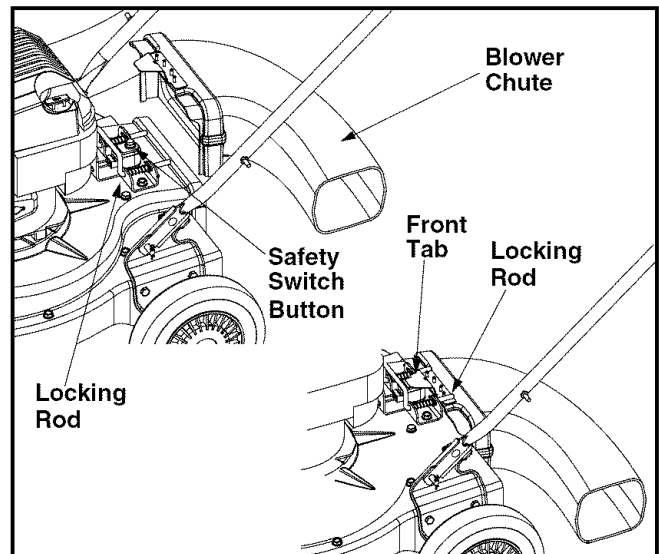

Figure 5

## SECTION 3: KNOW YOUR YARD VACUUM

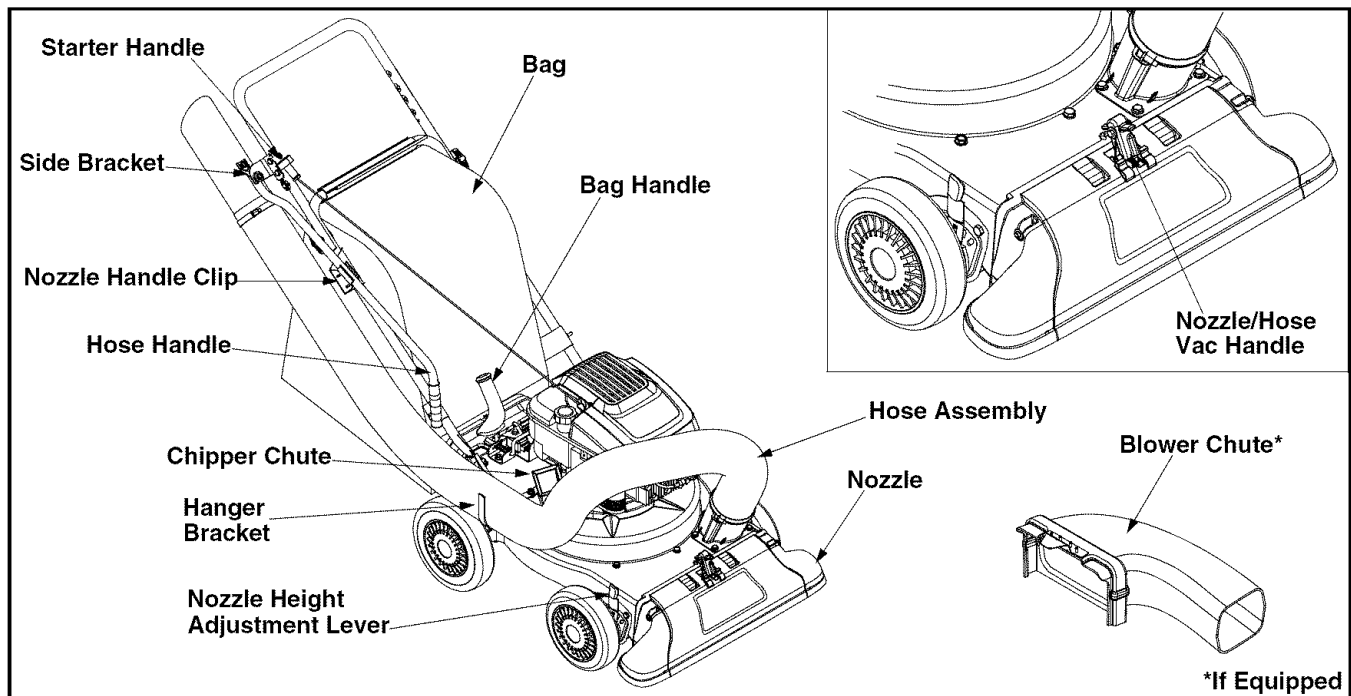

Figure 6

Read this operator's manual and safety rules before operating your Yard Vacuum. Compare the illustrations in Figure 6 with your unit to familiarize yourself with the location of various controls and adjustments.



**WARNING:** The operation of any Yard Vacuum can result in foreign objects being thrown into the eyes, which can result in severe eye damage. Always wear safety glasses, provided with the Yard Vacuum, for operating this equipment or while performing any adjustments or repairs on it.

### Starter Handle

The starter handle is attached to the right upper handle. Stand behind unit and pull the starter handle to start engine.

### Bag

Collects shredded material fed through the chipper chute or vacuumed through the nozzle or hose.

### Bag Handle

Used to grasp bag in order to assist in attaching, removing, and emptying bag.

### Chipper Chute

Allow twigs and small branches up to 1 1/2" in diameter to be fed into the impeller for chipping.

### Blower Chute (If Equipped)

When attached to unit the blower chute is used to blow or scatter yard waste such as leaves, pine needles, or small twigs across yard.

### Nozzle Height Adjustment Lever

Used to adjust the nozzle ground clearance ranging approximately 5/8" to 4 1/8".

### Nozzle

Yard waste such as leaves or pine needles can be vacuumed up through the nozzle for shredding.

### Hose Assembly

Used as an alternative to the nozzle to vacuum yard waste such as leaves or pine needles in hard to reach places.

### Hose Handle

Used to guide hose assembly when vacuuming.

### Nozzle/Hose Vac Handle

The nozzle/hose vac handle is located on top of the nozzle and it is used to regulate the vacuum between the nozzle and the hose assembly.

### Throttle Control Lever (Not Shown)

The throttle control lever is located on the engine. It controls the engine's speed and stops the engine. See separate engine manual packed with unit for details.

### Engine Controls

See the separate engine manual for the location and function of the controls on the engine.

---

## SECTION 4: OPERATING YOUR YARD VACUUM



**WARNING:** The operation of the Yard Vacuum can result in foreign objects being thrown into the eyes, which can damage your eyes severely. Always wear the safety glasses provided with this unit or eye shields before chipping or blowing and while performing any adjustments or repairs.

### Gas And Oil Fill-Up

Service the engine with gasoline and oil as instructed in the separate engine manual packed with your Yard Vacuum. Read instructions carefully.



**WARNING:** Never fill fuel tank indoors with engine running or until the engine has been allowed to cool for at least two minutes after running.

### Starting Engine

- Attach spark plug wire to spark plug. Make certain the metal cap on the end of the spark plug is fastened securely over the metal tip on the spark plug.
- Make sure safety switch wire is connected to engine and properly grounded.
- **Engines with choke lever:** Move choke lever on engine to CHOKE position. (A warm engine may not require choking).
- **Engines with primer:** Prime engine as instructed in separate engine manual.

- The throttle control is located on the engine. Move engine throttle control lever to FAST or ON position.
- Stand behind unit, grasp starter handle and pull rope out slowly until engine reaches start of compression cycle (rope will pull slightly harder at this point).
- Pull rope with a rapid, continuous, full arm stroke. Keep a firm grip on starter handle. Let rope rewind slowly.
- Repeat previous steps until engine fires. When engine starts, move choke control (if equipped) gradually to RUN position.



**WARNING:** Never run the engine indoors or in a poorly ventilated area. Engine exhaust contains carbon monoxide, an odorless and deadly gas.

### Stopping Engine

- Move throttle control lever to STOP or OFF position.
- Disconnect spark plug wire from spark plug and ground against the engine.

### To Empty Bag

- Unhook bag straps from the lower handle and unsnap bag clip from the top of lower handle. See Figure 7.
- Grasp bag handle with one hand and pull lock rod on mounting bracket with other hand toward engine to release.
- Remove bag from rim of the discharge opening. Refer to Figure 4.



- Twist the two buttons on the back of the bag to unlock and empty contents. See Figure 7.
- Hold bag handle and bag clip while emptying the contents.
- Compress bag opening and fold inner flap over opening.
- Fold outer flap over inner flap and insert buttons on the bag through metal outlets.
- Twist the buttons to lock bag.

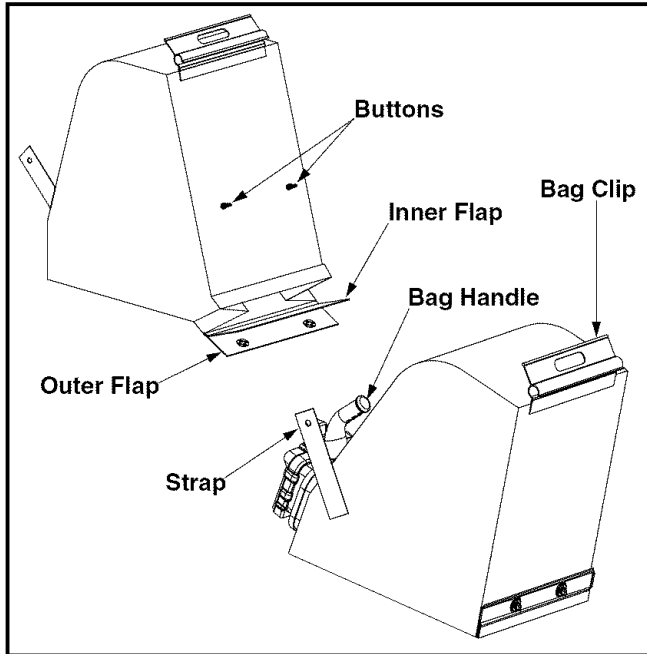

Figure 7

### To Remove Blower Chute (if Equipped)

- Grasp blower chute with one hand and pull lock rod on mounting bracket with other hand toward engine to release. Refer to Figure 5.
- Remove blower chute from rim of the discharge opening.

### Using the Nozzle Vacuum

- Place nozzle/hose vac handle in the top position on the nozzle to vacuum through nozzle. See Figure 8.
- The spring loaded pin must be in the first hole of the hose adapter to operate the nozzle vac.
- Place both hands on top of upper handle to push unit over yard waste.

Yard waste such as leaves and pine needles can be vacuumed up through the nozzle for shredding. After material has been shredded by the flail blades on the impeller assembly, it will be discharged into catcher bag or through blower chute (if equipped). Do not attempt to shred or chip any material other than vegetation found in a normal yard (i.e. branches, leaves, twigs, etc.) Avoid fibrous plants such as tomato vines until they are thoroughly dried out. Materials such as stalks or heavy branches up to 1 1/2" in diameter may be fed into the chipper chute.

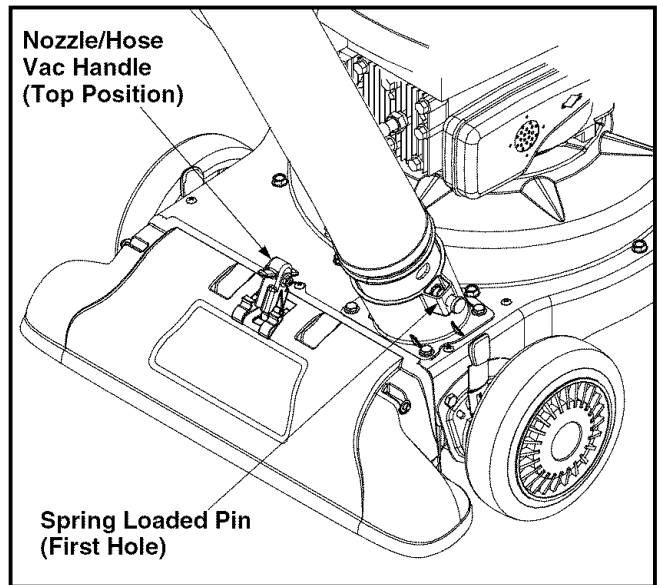

Figure 8

**IMPORTANT:** The flail screen is located inside the housing in the discharge area. If the flail screen becomes clogged, remove and clean as instructed in SECTION 5: MAINTAINING YOUR YARD VACUUM. For best performance, it is also important to keep the chipper blade sharp.



**WARNING:** Do not at any time make any adjustments without first stopping engine and disconnecting spark plug wire.

### Using the Hose Assembly

- Place nozzle/hose vac handle in the bottom position on the nozzle to redirect vacuum to the hose assembly. See Figure 9.
- The spring loaded pin must be in the second hole of the hose adapter to operate the hose assembly.
- Unhook the hose from upper handle bracket and grasp the hose handle to guide while vacuuming yard waste such as leaves or pine needles in hard to reach places.

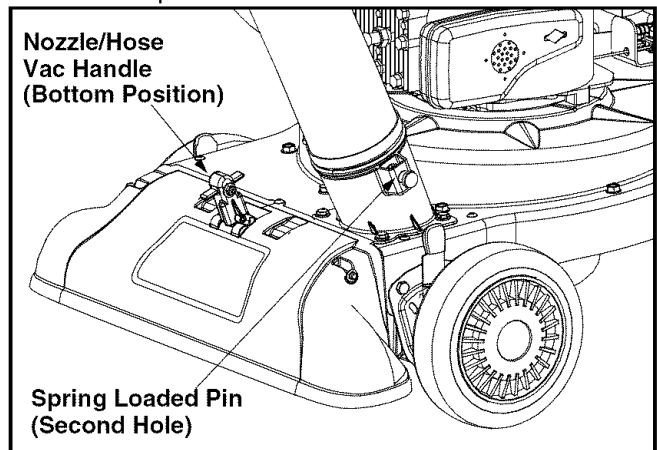

Figure 9

## Nozzle Height Adjustment

The nozzle can be adjusted to any six positions, ranging from 5/8" to 4 1/8" ground clearance. The nozzle height has to be adjusted according to the conditions. Move the height adjustment levers forward or backward to adjust the nozzle upwards or downwards. Make sure both levers are in the same position. See Figure 10.

**NOTE:** In general, raise the nozzle height to vacuum a thick layer of leaves or to operate with the blower chute (if equipped) and lower the nozzle height for smoother surfaces.

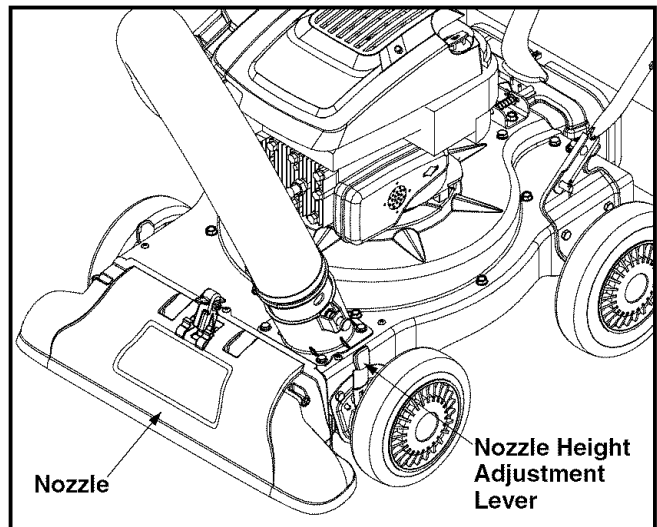

Figure 10

## SECTION 5: MAINTAINING YOUR YARD VACUUM

### Customer Responsibilities

MAINTENANCE SCHEDULE		Before each Use	Every 25 hours	Every 50 hours	Every 100 hours	Once a season	Before storage	SERVICE DATES						
PRODUCT	Lubricate Wheels					✓								
	Lubricate Nozzle Levers					✓								
	Lubricate Locking Rod					✓								
	Lubricate Nozzle/Hose Handle					✓								
	Check Chipper Blade		✓			✓								
ENGINE	Change Oil		✓				✓							
	Check Air Filter		✓			✓								
	Clean Engine	✓					✓							
	Check Spark Plug			✓		✓								



**WARNING:** Always stop engine and disconnect spark plug wire before cleaning, lubricating or doing any kind of maintenance on your machine.

### Lubrication

**Wheels:** Lubricate each wheel shoulder screw once a season with light oil. Refer to Figure 6.

**Nozzle height adjustment levers:** Lubricate the pivot points of the nozzle height adjustment levers once a season with light oil. Refer to Figure 6.

**Locking Rod:** Lubricate the locking rod with light oil to ease the application of attaching on or removing bag or blower chute (if equipped). Refer to Figure 6.

**Nozzle/Hose Vac Handle:** Lubricate the nozzle/hose vac handle on top of nozzle once a season with light oil. Refer to Figure 6.

**Engine:** Follow the separate engine manual packed with your unit for lubrication instructions.

# Maintenance

## Engine

Refer to the separate engine manual for all engine maintenance instructions.

- Check **engine oil level** before each use as instructed in the separate engine manual packed with your unit. Read and follow instructions carefully.
- Clean **air cleaner** every 25 hours under normal conditions or once a season. Clean every few hours under extremely dusty conditions. To service the air cleaner, refer to the separate engine manual packed with your unit.
- The **spark plug** should be cleaned and the gap reset once a season. Check engine manual for correct plug type and gap specifications.

## Removing The Flail Screen

If the discharge area becomes clogged, remove the flail screen and clean area as follows:

- Stop the engine and make certain the Yard Vacuum has come to a complete stop.
- Disconnect spark plug wire from spark plug and ground against the engine.
- Remove the bag or blower chute (if equipped) from the unit as instructed in the OPERATION section to obtain access to flail screen. See Figure 11.

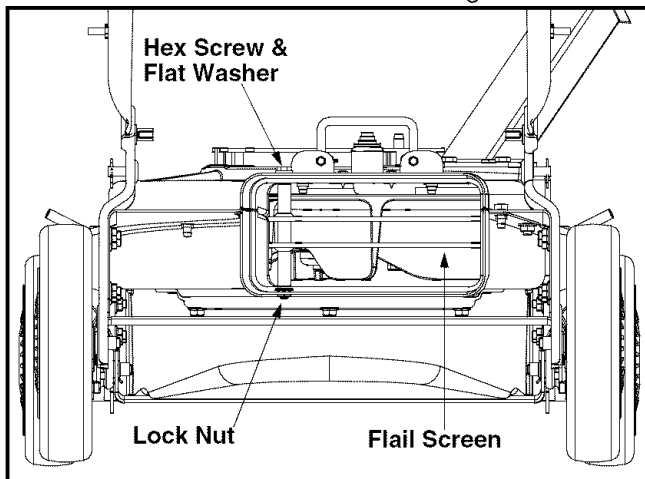

Figure 11

- Remove self-tapping screw on right side of unit that attaches to the flail screen. It may be necessary to remove the hose bracket hanger to get access to the hex screw. See Figure 12.
- Remove hex screw on top of rear housing mounting bracket and the flange lock nut that secures flail screen. See Figure 11.
- Remove and clean the screen by scraping or washing with water. Reinstall the flail screen.

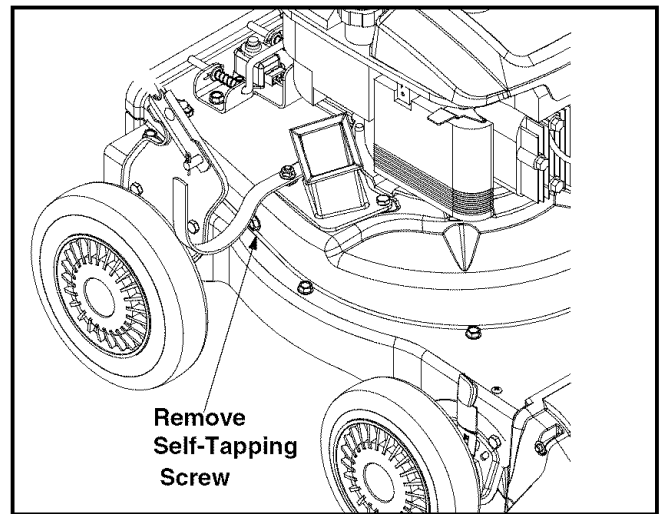

Figure 12

## Sharpening Or Replacing Chipper Blade

Because the engine on this unit has a tapered crankshaft, a special impeller tool (part number 753-0900) is required to remove the impeller assembly. For further assistance, contact your local service dealer.

**NOTE:** When tipping the unit, empty the fuel tank and keep spark plug side up.

- Disconnect the spark plug wire and ground it away from the spark plug.
- Remove the front hubcaps, flange lock nuts, front wheels, and wave washers that attach to the pivot arm assemblies. See Figure 13.

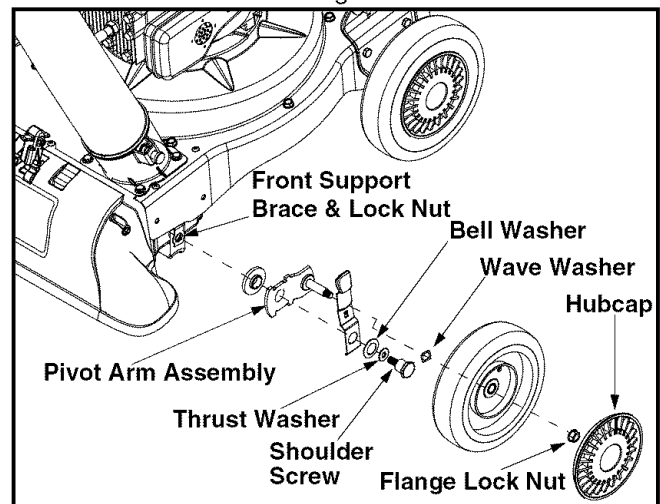
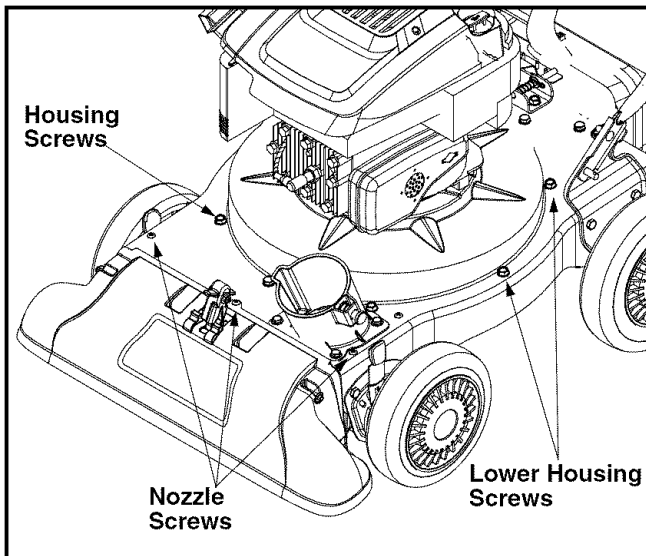

Figure 13

- Remove the shoulder screws, thrust and bell washers that go through the pivot arms to the front support brace. The front support brace and lock nut can be removed at this time as well.
- Remove the three screws on the upper housing that secure the nozzle cover and the nine screws that secure the lower housing to the upper housing. See Figure 14.



**Figure 14**

- Remove flange lock nut that secures flail screen to the lower housing. The flail screen does not have to be removed. Refer to Figure 11.
- Remove the hex bolt, lock washer, and flat washer that secure the impeller assembly to the crankshaft. See Figure 15.

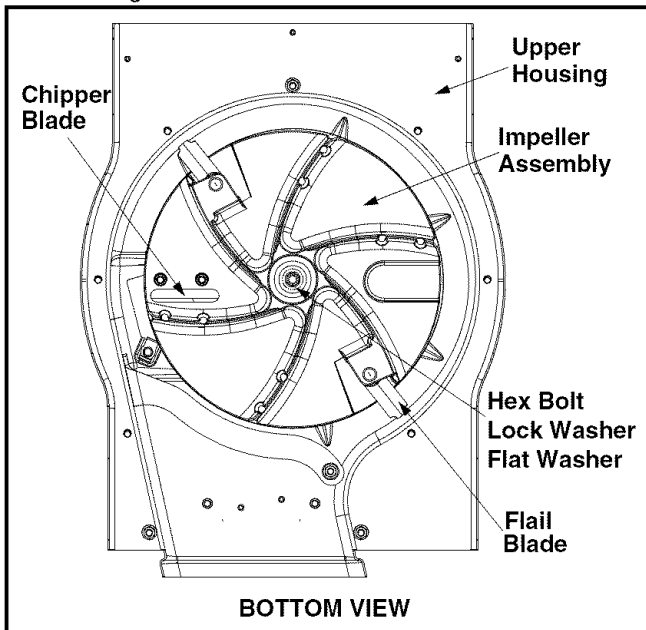

**Figure 15**

- Apply lubricant to the threads of impeller removal tool and then thread the tool into the crankshaft. Stop when the impeller assembly can move on the crankshaft.
- Remove the impeller assembly from the crankshaft. Unthread the impeller removal tool from the impeller assembly.
- Remove the blade using a 3/16" allen wrench on the outside of the blade and 1/2" wrench on the impeller assembly.
- Replace or sharpen chipper blade.
- When sharpening blade, protect hands by using gloves and follow the original angle of grind.
- Reassemble by performing the previous steps in reverse order.
- Tighten blade screws to 210-250 in-lbs. Tighten impeller bolt to 375-425 in-lbs.

**NOTE:** Make certain chipper blade is reassembled with the sharp edge facing upward. See Figure 16.

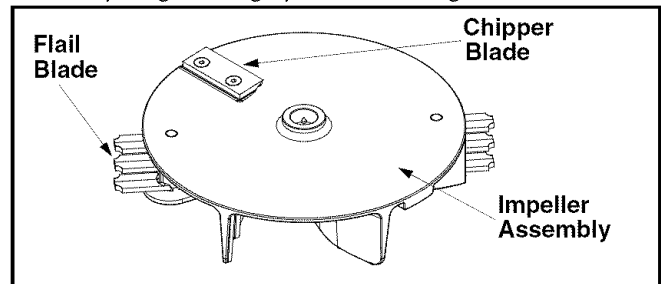

**Figure 16**

## Storing Your Yard Vacuum

- Clean the equipment thoroughly.
- Wipe equipment with a oiled rag to prevent rust.
- Refer to engine manual for correct engine storage instructions.
- Store unit in a clean, dry area. Do not store next to corrosive materials such as fertilizer.

## SECTION 6: TROUBLESHOOTING

Problem	Cause	Remedy
Engine fails to start	<ol style="list-style-type: none"> <li>1. Spark plug wire disconnected.</li> <li>2. Fuel tank empty or stale fuel.</li> <li>3. Throttle control lever not in correct starting position.</li> <li>4. Choke not in CHOKE position. (If Equipped)</li> <li>5. Engine (if equipped with a primer) not primed properly.</li> <li>6. Blocked fuel line.</li> <li>7. Faulty spark plug.</li> </ol>	<ol style="list-style-type: none"> <li>1. Connect wire to spark plug.</li> <li>2. Fill tank with clean, fresh gasoline.</li> <li>3. Move throttle lever to FAST position.</li> <li>4. Move choke to CHOKE position.</li> <li>5. Prime engine.</li> <li>6. Clean fuel line.</li> <li>7. Clean, adjust gap, or replace.</li> </ol>
Engine runs erratic	<ol style="list-style-type: none"> <li>1. Spark plug wire loose.</li> <li>2. Unit running on CHOKE. (If Equipped)</li> <li>3. Blocked fuel line or stale fuel.</li> <li>4. Water or dirt in fuel system.</li> <li>5. Dirty air cleaner.</li> <li>6. Carburetor out of adjustment.</li> </ol>	<ol style="list-style-type: none"> <li>1. Connect and tighten spark plug wire.</li> <li>2. Move choke lever to OFF position.</li> <li>3. Clean fuel line; fill tank with clean, fresh gasoline.</li> <li>4. Drain fuel tank. Refill with fresh fuel.</li> <li>5. Clean or replace air cleaner.</li> <li>6. See authorized service dealer.</li> </ol>
Too much vibration	<ol style="list-style-type: none"> <li>1. Loose parts or damaged impeller.</li> </ol>	<ol style="list-style-type: none"> <li>1. See authorized service dealer.</li> </ol>
Engine overheats	<ol style="list-style-type: none"> <li>1. Engine oil level low.</li> <li>2. Dirty air cleaner.</li> <li>3. Carburetor not adjusted properly.</li> </ol>	<ol style="list-style-type: none"> <li>1. Fill crankcase with proper oil.</li> <li>2. Clean or replace air cleaner.</li> <li>3. See authorized service dealer.</li> </ol>
Occasional skip (hesitates) at high speed	<ol style="list-style-type: none"> <li>1. Spark plug gap too close.</li> </ol>	<ol style="list-style-type: none"> <li>1. Adjust gap to .030".</li> </ol>
Unit does not discharge	<ol style="list-style-type: none"> <li>1. Discharge chute clogged.</li> <li>2. Foreign object lodged in impeller.</li> <li>3. Low engine RPM</li> <li>4. Vacuum bag is full.</li> </ol>	<ol style="list-style-type: none"> <li>1. Stop engine immediately and disconnect spark plug wire. Clean flail screen and inside of discharge opening.</li> <li>2. Stop engine and disconnect spark plug wire. Remove lodged object.</li> <li>3. Always run engine at full throttle.</li> <li>4. Empty bag.</li> </ol>
Rate of discharge slows considerably or composition of discharged material changes.	<ol style="list-style-type: none"> <li>1. Low engine RPM.</li> <li>2. Chipper blade dull.</li> </ol>	<ol style="list-style-type: none"> <li>1. Always run engine at full throttle.</li> <li>2. Replace chipper blade or see your authorized service dealer.</li> </ol>

**NOTE:** For repairs beyond the minor adjustments listed above, contact your nearest authorized service dealer.

# SECTION 7: PARTS LIST FOR MODEL 24B-060F766

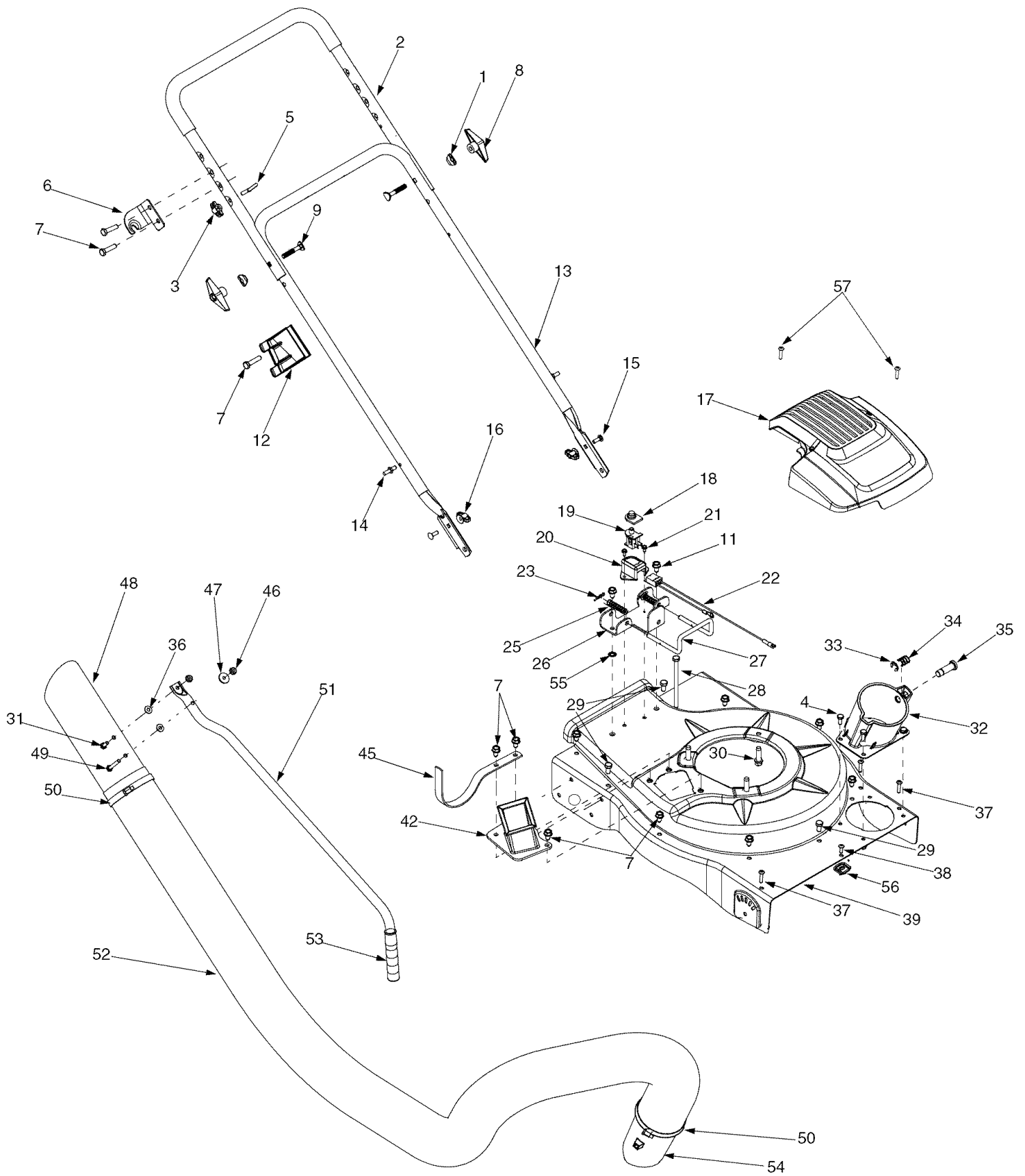

# Model 24B-060F766

Ref. No.	Part No.	Part Description	Ref. No.	Part No.	Part Description
1.	736-0451	Saddle Washer, .320 x.93	29.	710-3025	Hex Cap Screw 5/16-18 x.625
2.	749-04172	Upper Handle	30.	710-0502A	Hex Washer Screw 3/8-16 x 1.25
3.	720-0279	Knob	31.	710-0751	Hex Cap Screw 1/4-20 x.620
4.	710-0599	Screw, 1/4-20 x.500	32.	731-2484	Hose Base Adapter
5.	710-1205	Eye Bolt	33.	716-0104	E Ring.500 Dia
6.	781-1056	Upper Handle Bracket	34.	732-3035	Compression Spring
7.	710-0726	Hex Cap Screw 5/16-12 x.750	35.	711-1571	Clevis Pin
8.	720-0241	Handle Knob 5/16-18	36.	736-3020	Flat Washer.271 ID x.630 OD
9.	710-1174	Carriage Bolt	37.	710-1220	Screw, #12-16 x.750
12.	731-04911	Nozzle Handle Clip	38.	710-0351	Screw #10 - 16 x.500
13.	749-04165	Lower Handle	39.	781-04071	Upper Flail Housing
14.	711-1293	Studs	42.	681-0122	Chipper Chute Assembly
15.	710-0703	Carriage Screw 1/4-20 x.75	45.	781-1058	Hose Hanger Bracket
16.	712-0397	Wing Nut 1/4-20	46.	712-04064	Flange Lock Nut, 1/4-20
17.	751B699869	Shroud	47.	748-0457	Spacer
18.	725-1700	Switch Cover	48.	731-2478	Hose Nozzle
19.	725-3166	Safety Switch	49.	710-3288	Hex Cap Screw 1/4-20 x 2.625
20.	731-1613	Safety Switch Cover	50.	723-0295	Adjustment Clamp
21.	710-0224	Hex Washer Screw #10-16 x.50	51.	749-1270	Nozzle Handle
22.	629-0920A	Wire Harness	52.	764-0648	Vacuum Hose
23.	714-0104	Cotter Pin	53.	07071	Handle Grip
25.	732-0962	Compression Spring	54.	731-2292	Hose Adapter
26.	781-0778A	Mounting Bracket	55.	736-0607	External L-Washer 5/16
27.	747-1153	Lock Rod	56.	726-0139	Speed Nut
28.	710-3195	Hex Cap Screw 5/16-18 x 4.5	57.	710-1256	Hex Screw, #8-18 x 1.25

# Model 24B-060F766

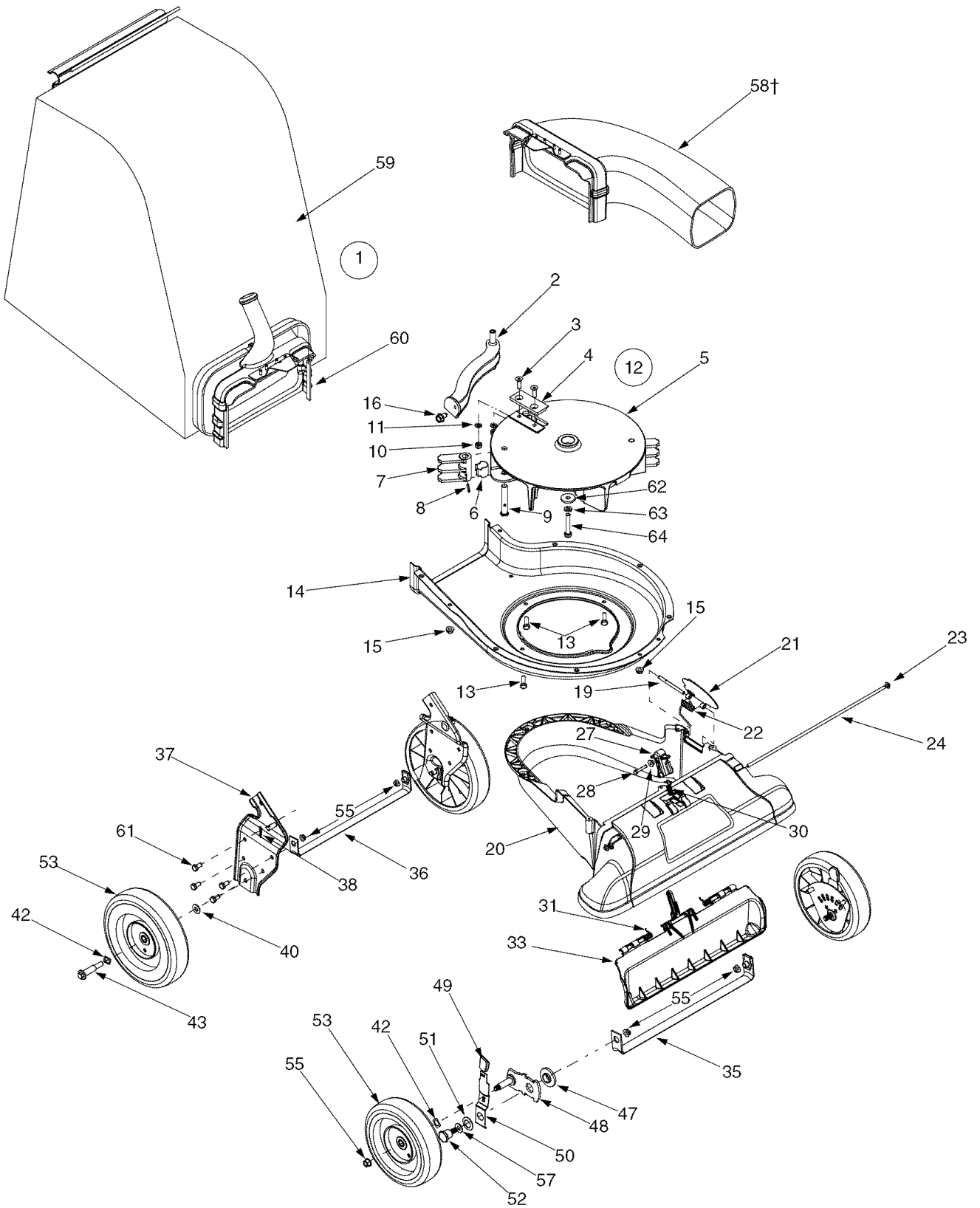

† If Equipped



# Model 24B-060F766

Ref. No.	Part No.	Part Description	Ref. No.	Part No.	Part Description
1.	664-0095	Bag Assembly	31.	732-1151A	Nozzle Door Torsion Spring
2.	681-0154	Screen Assembly	33.	731-2294A	Nozzle Door
3.	710-1054	Hex Screw 5/16-24 x 1.0	35.	781-04082	Front Wheel Support Brace
4.	781-0490	Chipper Blade	36.	781-04081	Rear Wheel Support Brace
5.	719-0530A	Impeller	37.	681-0156A	Handle Bracket Ass'y RH
6.	781-0735	Pin Clip		681-0155A	Handle Brkt Ass'y LH (Not Shown)
7.	719-0329	Flail	38.	714-0104	Cotter Pin
8.	715-0166	Spiral Pin	40.	736-0105	Bell Washer.401 ID x.870 OD
9.	711-1401	Clevis Pin	42.	736-0232	Wave Washer.531 ID x.781 OD
10.	712-0411	Lock Nut, 5/16-24	43.	738-1015	Shoulder Screw 3/8-16
11.	736-0119	Lock Washer, 5/16	47.	741-0751	Height Adjustment Bearing
12.	681-0152	Impeller Assembly (Incl. Ref 3 – Ref. 11)	48.	687-02094	Pivot Arm Assembly
13.	710-1650	Shoulder Screw, #12-24 x.30 x.46	49.	720-0426	Height Adjustment Knob
14.	781-0721B	Lower Flail Housing	50.	732-1026	Spring Lever
15.	712-04063	Flange Lock Nut 5/16-18	51.	736-0741	Bell Washer.760 ID x.25 OD
16.	710-0607	Screw, 5/16-18 x.500	52.	738-1172	Shoulder Screw,.750 x.500
19.	747-04297	Hinge Pin	53.	734-04033	Wheel 8 x 2
20.	731-2293A	Nozzle	55.	712-04065	Flange Lock Nut, 3/8-16
21.	781-1064	Base Adapter Door	57.	736-0314	Thrust Washer.375 ID x.70 OD
22.	732-1156	Torsion Spring	58.	OEM-290-012†	Blower Chute
23.	726-0106	Cap Speed Nut 1/4	59.	764-0632A	Bag
24.	711-1551	Pivot Rod	60.	631-0083	Chute Assembly
27.	731-2485A	Nozzle Door Lever	61.	710-0726	Hex Index Screw, 5/16-12 x.750
28.	710-1256	Hex Screw, #8-18 x 1.25	62.	736-0247	Flat Washer.375 ID x 1.25 OD
29.	750-1294	Shoulder Spacer	63.	736-0217	Lock Washer 3/8
30.	732-3118	Extension Spring	64.	710-0818	Hex Cap Screw 3/8-24 x 2.0
			—	723-0400	Safety Glasses (Not Shown)

†If Equipped

## NOTES

## NOTES

# MANUFACTURER'S LIMITED WARRANTY FOR:



The limited warranty set forth below is given by Troy-Bilt LLC with respect to new merchandise purchased and used in the United States, its possessions and territories.

"Troy-Bilt" warrants this product against defects in material and workmanship for a period of two (2) years commencing on the date of original purchase and will, at its option, repair or replace, free of charge, any part found to be defective in materials or workmanship. This limited warranty shall only apply if this product has been operated and maintained in accordance with the Operator's Manual furnished with the product, and has not been subject to misuse, abuse, commercial use, neglect, accident, improper maintenance, alteration, vandalism, theft, fire, water, or damage because of other peril or natural disaster. Damage resulting from the installation or use of any part, accessory or attachment not approved by Troy-Bilt for use with the product(s) covered by this manual will void your warranty as to any resulting damage.

Normal wear parts are warranted to be free from defects in material and workmanship for a period of thirty (30) days from the date of purchase. Normal wear parts include, but are not limited to items such as: batteries, belts, blades, blade adapters, grass bags, rider deck wheels, seats, snow thrower skid shoes, shave plates, auger spiral rubber and tires.

**HOW TO OBTAIN SERVICE:** Warranty service is available, WITH PROOF OF PURCHASE, through your local authorized service dealer. To locate the dealer in your area, check your Yellow Pages, or contact Troy-Bilt LLC at P.O. Box 361131, Cleveland, Ohio 44136-0019, or call 1-800-520-5520 or 1-330-558-7220, or log on to our Web site at [www.troybilt.com](http://www.troybilt.com).

This limited warranty does not provide coverage in the following cases:

- a. The engine or component parts thereof. These items may carry a separate manufacturer's warranty. Refer to applicable manufacturer's warranty for terms and conditions.
- b. Log splitter pumps, valves, and cylinders have a separate one year warranty.
- c. Routine maintenance items such as lubricants, filters, blade sharpening, tune-ups, brake adjustments, clutch adjustments, deck adjustments, and normal deterioration of the exterior finish due to use or exposure.
- d. Service completed by someone other than an authorized service dealer.
- e. Troy-Bilt does not extend any warranty for products sold or exported outside of the United States, its possessions and territories, except those sold through Troy-Bilt's authorized channels of export distribution.
- f. Replacement parts that are not genuine Troy-Bilt parts.
- g. Transportation charges and service calls.

**No implied warranty, including any implied warranty of merchantability of fitness for a particular purpose, applies after the applicable period of express written warranty above as to the parts as identified. No other express warranty, whether written or oral, except as mentioned above, given by any person or entity, including a dealer or retailer, with respect to any product, shall bind Troy-Bilt. During the period of the warranty, the exclusive remedy is repair or replacement of the product as set forth above.**

**The provisions as set forth in this warranty provide the sole and exclusive remedy arising from the sale. Troy-Bilt shall not be liable for incidental or consequential loss or damage including, without limitation, expenses incurred for substitute or replacement lawn care services or for rental expenses to temporarily replace a warranted product.**

Some states do not allow the exclusion or limitation of incidental or consequential damages, or limitations on how long an implied warranty lasts, so the above exclusions or limitations may not apply to you.

In no event shall recovery of any kind be greater than the amount of the purchase price of the product sold. **Alteration of safety features of the product shall void this warranty.** You assume the risk and liability for loss, damage, or injury to you and your property and/or to others and their property arising out of the misuse or inability to use the product.

This limited warranty shall not extend to anyone other than the original purchaser or to the person for whom it was purchased as a gift.

**HOW STATE LAW RELATES TO THIS WARRANTY:** This limited warranty gives you specific legal rights, and you may also have other rights which vary from state to state.

**IMPORTANT:** Owner must present Original Proof of Purchase to obtain warranty coverage.