

Owner's Manual



# LAWN TRACTOR

15.5 HP, 38" Mower

Electric Start

5 Speed Transaxle

Model No.

**917.277252**

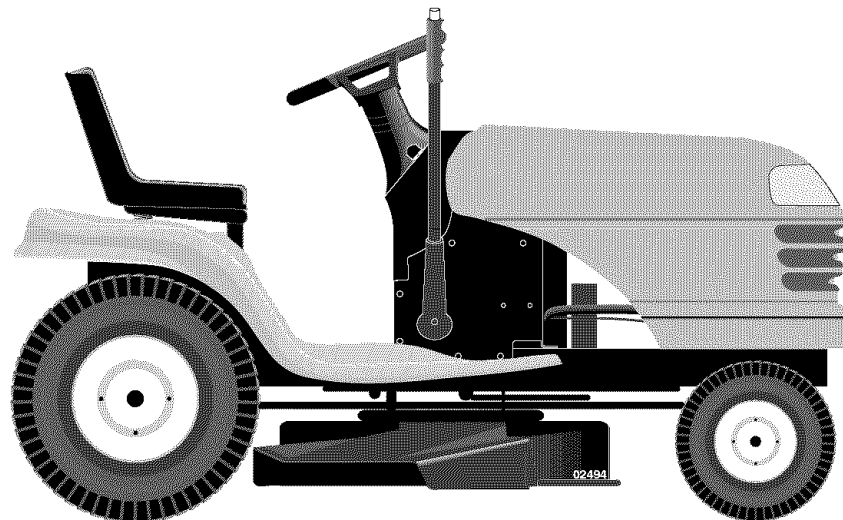

**This product has a low emission engine which operates differently from previously built engines. Before you start the engine, read and understand this Owner's Manual.**

## **IMPORTANT:**

Read and follow all Safety Rules and Instructions before operating this equipment.

For answers to your questions about this product, Call:

**1-800-659-5917**  
Sears Craftsman Help Line  
5 am - 5 pm, Mon - Sat

Sears, Roebuck and Co., Hoffman Estates, IL 60179 U.S.A.

Visit our Craftsman website: [www.sears.com/craftsman](http://www.sears.com/craftsman)

## TABLE OF CONTENTS

Warranty .....	2	Maintenance .....	17
Safety Rules .....	3	Service and Adjustments.....	21
Product Specifications .....	6	Storage .....	27
Assembly/Pre-Operation .....	8	Troubleshooting .....	28
Operation.....	11	Repair Parts.....	32
Maintenance Schedule .....	17	Sears Service .....	Back Cover

## WARRANTY

### LIMITED WARRANTY ON CRAFTSMAN RIDING EQUIPMENT

For two (2) years from the date of purchase, if this Craftsman Riding Equipment is maintained, lubricated and tuned up according to the instructions in the owner's manual, Sears will repair or replace free of charge any parts that are found to be defective in material or workmanship according to the guidelines of coverage listed below. Sears will also provide free labor for these applicable warranted parts for the two full years. During the first 30 days of purchase, there will be no charges to service the product at your home for issues covered by this warranty. (See exclusions below). For your convenience, IN HOME warranty service will still be available after the first 30 days of purchase, but a trip charge will apply. This charge will be waived if the Craftsman product is dropped off at an authorized Sears location. For the nearest authorized Sears location, please call 1-800-4-MY-HOME®. This warranty applies only while this product is within the United States.

This Warranty does not cover:

- Expendable items which become worn during normal use, including but not limited to blades, spark plugs, air cleaners, belts, and oil filters.  
Standard Maintenance Servicing, oil changes, or tune-ups
- Tire replacement or repair caused by punctures from outside objects, such as nails, thorns, stumps, or glass.
- Repairs necessary because of operator abuse, including but not limited to, damage caused by towing objects beyond the capability of the riding equipment, impacting objects that bend the frame or crankshaft, or over-speeding the engine.
- Repairs necessary because of operator negligence, including but not limited to, electrical and mechanical damage caused by improper storage, failure to use the proper grade and amount of engine oil, failure to keep the deck clear of flammable debris, or failure to maintain the equipment according to the instructions contained in the owner's manual.
- Engine (fuel system) cleaning or repairs caused by fuel determined to be contaminated or oxidized (stale). In general, fuel should be used within 30 days of its purchase date.
- Normal deterioration and wear of the exterior finishes, or product label replacement.
- Riding equipment used for commercial or rental purposes.

### LIMITED WARRANTY ON BATTERY

For ninety (90) days from date of purchase, if any battery included with this riding equipment proves defective in material or workmanship and our testing determines the battery will not hold a charge, Sears will replace the battery at no charge. During the first 30 days of purchase, there will be no charges to replace the battery at your HOME. After the first 30 days, for your convenience, IN-HOME warranty service will still be available but a trip charge will apply. This charge will be waived if the Craftsman product is dropped off at an authorized Sears location. For the nearest authorized Sears location, please call 1-800-4-MY-HOME®.

This battery warranty applies only while this product is within the United States.

This warranty gives you specific legal rights, and you may also have other rights, which vary, from state to state.

Sears, Roebuck and Co., Dept. 817WA, Hoffman Estates, IL 60179

# SAFETY RULES

**IMPORTANT:** This cutting machine is capable of amputating hands and feet and throwing objects. Failure to observe the following safety instructions could result in serious injury or death.

 **WARNING:** In order to prevent accidental starting when setting up, transporting, adjusting or making repairs, always disconnect spark plug wire and place wire where it cannot contact spark plug.

 **WARNING:** Do not coast down a hill in neutral, you may lose control of the tractor.

 **WARNING:** Tow only the attachments that are recommended by and comply with specifications of the manufacturer of your tractor. Use common sense when towing. Operate only at the lowest possible speed when on a slope. Too heavy of a load, while on a slope, is dangerous. Tires can lose traction with the ground and cause you to lose control of your tractor.

 **WARNING:** Engine exhaust, some of its constituents, and certain vehicle components contain or emit chemicals known to the State of California to cause cancer and birth defects or other reproductive harm.

 **WARNING:** Battery posts, terminals and related accessories contain lead and lead compounds, chemicals known to the State of California to cause cancer and birth defects or other reproductive harm.  
**Wash hands after handling.**

## I. GENERAL OPERATION

- Read, understand, and follow all instructions on the machine and in the manual before starting.
- Do not put hands or feet near rotating parts or under the machine. Keep clear of the discharge opening at all times.
- Only allow responsible adults, who are familiar with the instructions, to operate the machine.
- Clear the area of objects such as rocks, toys, wire, etc., which could be picked up and thrown by the blades.
- Be sure the area is clear of bystanders before operating. Stop machine if anyone enters the area.
- Never carry passengers.

- Do not mow in reverse unless absolutely necessary. Always look down and behind before and while backing.
- Never direct discharged material toward anyone. Avoid discharging material against a wall or obstruction. Material may ricochet back toward the operator. Stop the blades when crossing gravel surfaces.
- Do not operate machine without the entire grass catcher, discharge guard, or other safety devices in place and working.
- Slow down before turning.
- Never leave a running machine unattended. Always turn off blades, set parking brake, stop engine, and remove keys before dismounting.
- Disengage blades when not mowing. Shut off engine and wait for all parts to come to a complete stop before cleaning the machine, removing the grass catcher, or unclogging the discharge guard.
- Operate machine only in daylight or good artificial light.
- Do not operate the machine while under the influence of alcohol or drugs.
- Watch for traffic when operating near or crossing roadways.
- Use extra care when loading or unloading the machine into a trailer or truck.
- Always wear eye protection when operating machine.
- Data indicates that operators, age 60 years and above, are involved in a large percentage of riding mower-related injuries. These operators should evaluate their ability to operate the riding mower safely enough to protect themselves and others from serious injury.
- Follow the manufacturer's recommendation for wheel weights or counterweights.
- Keep machine free of grass, leaves or other debris build-up which can touch hot exhaust / engine parts and burn. Do not allow the mower deck to plow leaves or other debris which can cause build-up to occur. Clean any oil or fuel spillage before operating or storing the machine. Allow machine to cool before storage.

# SAFETY RULES

## II. SLOPE OPERATION

Slopes are a major factor related to loss of control and tip-over accidents, which can result in severe injury or death. Operation on all slopes requires extra caution. If you cannot back up the slope or if you feel uneasy on it, do not mow it.

- Mow up and down slopes, not across.
- Watch for holes, ruts, bumps, rocks, or other hidden objects. Uneven terrain could overturn the machine. Tall grass can hide obstacles.
- Choose a low ground speed so that you will not have to stop or shift while on the slope.
- Do not mow on wet grass. Tires may lose traction.

Always keep the machine in gear when going down slopes. Do not shift to neutral and coast downhill.

- Avoid starting, stopping, or turning on a slope. If the tires lose traction, disengage the blades and proceed slowly straight down the slope.
- Keep all movement on the slopes slow and gradual. Do not make sudden changes in speed or direction, which could cause the machine to roll over.
- Use extra care while operating machine with grass catchers or other attachments; they can affect the stability of the machine. Do not use on steep slopes.
- Do not try to stabilize the machine by putting your foot on the ground.
- Do not mow near drop-offs, ditches, or embankments. The machine could suddenly roll over if a wheel is over the edge or if the edge caves in.

## III. CHILDREN

Tragic accidents can occur if the operator is not alert to the presence of children. Children are often attracted to the machine and the mowing activity. Never assume that children will remain where you last saw them.

- Keep children out of the mowing area and in the watchful care of a responsible adult other than the operator.
- Be alert and turn machine off if a child enters the area.
- Before and while backing, look behind and down for small children.

- Never carry children, even with the blades shut off. They may fall off and be seriously injured or interfere with safe machine operation. Children who have been given rides in the past may suddenly appear in the mowing area for another ride and be run over or backed over by the machine.
- Never allow children to operate the machine.
- Use extra care when approaching blind corners, shrubs, trees, or other objects that may block your view of a child.

## IV. TOWING

- Tow only with a machine that has a hitch designed for towing. Do not attach towed equipment except at the hitch point.
- Follow the manufacturer's recommendation for weight limits for towed equipment and towing on slopes.
- Never allow children or others in or on towed equipment.
- On slopes, the weight of the towed equipment may cause loss of traction and loss of control.
- Travel slowly and allow extra distance to stop.

## V. SERVICE

### SAFE HANDLING OF GASOLINE

To avoid personal injury or property damage, use extreme care in handling gasoline. Gasoline is extremely flammable and the vapors are explosive.

- Extinguish all cigarettes, cigars, pipes, and other sources of ignition.
- Use only approved gasoline container.
- Never remove gas cap or add fuel with the engine running. Allow engine to cool before refueling.
- Never fuel the machine indoors.
- Never store the machine or fuel container where there is an open flame, spark, or pilot light such as on a water heater or other appliances.
- Never fill containers inside a vehicle or on a truck or trailer bed with plastic liner. Always place containers on the ground away from your vehicle when filling.

# SAFETY RULES

- Remove gas-powered equipment from the truck or trailer and refuel it on the ground. If this is not possible, then refuel such equipment with a portable container, rather than from a gasoline dispenser nozzle.
- Keep the nozzle in contact with the rim of the fuel tank or container opening at all times until fueling is complete. Do not use a nozzle lock-open device.
- If fuel is spilled on clothing, change clothing immediately.
- Never overfill fuel tank. Replace gas cap and tighten securely.
- Check their proper operation regularly.
- Keep machine free of grass, leaves, or other debris build-up. Clean oil or fuel spillage and remove any fuel-soaked debris. Allow machine to cool before storing.
- If you strike a foreign object, stop and inspect the machine. Repair, if necessary, before restarting.
- Never make any adjustments or repairs with the engine running.
- Check grass catcher components and the discharge guard frequently and replace with manufacturer's recommended parts, when necessary.
- Mower blades are sharp. Wrap the blade or wear gloves, and use extra caution when servicing them.
- Check brake operation frequently. Adjust and service as required.
- Maintain or replace safety and instruction labels, as necessary.

## GENERAL SERVICE

- Never operate machine in a closed area.
- Keep all nuts and bolts tight to be sure the equipment is in safe working condition.
- Never tamper with safety devices.

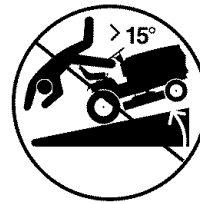

- Be sure the area is clear of bystanders before operating. Stop machine if anyone enters the area.
- Never carry passengers.
- Do not mow in reverse unless absolutely necessary. Always look down and behind before and while backing.
- Never carry children, even with the blades shut off. They may fall off and be seriously injured or interfere with safe machine operation. Children who have been given rides in the past may suddenly appear in the mowing area for another ride and be run over or backed over by the machine.
- Keep children out of the mowing area and in the watchful care of a responsible adult other than the operator.
- Be alert and turn machine off if a child enters the area.
- Before and while backing, look behind and down for small children.
- Mow up and down slopes (15° Max), not across.
- Choose a low ground speed so that you will not have to stop or shift while on the slope.
- Avoid starting, stopping, or turning on a slope. If the tires lose traction, disengage the blades and proceed slowly straight down the slope.
- If machine stops while going uphill, disengage blades, shift into reverse and back down slowly.
- Do not turn on slopes unless necessary, and then, turn slowly and gradually downhill, if possible.

## PRODUCT SPECIFICATIONS

Gasoline Capacity and Type:	1.25 Unleaded Regular
Oil Type (API-SG-SL):	SAE 30 (above 32°F) SAE 5W-30(below 32°F)
Oil Capacity:	3.0 Pints
Spark Plug: (Gap: .030")	Champion RC12YC
Ground Speed (MPH):	Forward: 1st 1.1 2nd 2.2 3rd 3.3 4th 4.4 5th 4.9 Reverse: 1.4
Tire Pressure:	Front: 14 PSI Rear: 12 PSI
Charging System:	3 Amps Battery 5 Amps Headlights
Battery:	Amp/Hr: 28 Min. CCA: 230 Case Size: U1R
Blade Bolt Torque:	27-35 Ft. Lbs.

**CONGRATULATIONS** on your purchase of a new tractor. It has been designed, engineered and manufactured to give you the best possible dependability and performance. Should you experience any problem you cannot easily remedy, please contact a Sears or other qualified service center. We have competent, well-trained technicians and the proper tools to service or repair this tractor. Please read and retain this manual. The instructions will enable you to assemble and maintain your tractor properly. Always observe the "SAFETY RULES".

### CUSTOMER RESPONSIBILITIES

- Read and observe the safety rules.
- Follow a regular schedule in maintaining, caring for and using your tractor.
- Follow the instructions under "Maintenance" and "Storage" sections of this owner's manual.

**⚠ WARNING:** This tractor is equipped with an internal combustion engine and should not be used on or near any unimproved forest-covered, brush-covered or grass-covered land unless the engine's exhaust system is equipped with a spark arrester meeting applicable local or state laws (if any). If a spark arrester is used, it should be maintained in effective working order by the operator.

In the state of California the above is required by law (Section 4442 of the California Public Resources Code). Other states may have similar laws. Federal laws apply on federal lands. A spark arrester for the muffler is available through your nearest Sears service center (See REPAIR PARTS section of this manual).

## REPAIR PROTECTION AGREEMENTS

Congratulations on making a smart purchase. Your new Craftsman® product is designed and manufactured for years of dependable operation. But like all products, it may require repair from time to time. That's when having a Repair Protection Agreement can save you money and aggravation. *Purchase a Repair Protection Agreement now and protect yourself from unexpected hassle and expense.*

Here's what's included in the Agreement:

- Expert service by our 12,000 professional repair specialists.
- Unlimited service and no charge for parts and labor on all covered repairs.
- Product replacement if your covered product can't be fixed.
- Discount of 10% from regular price of service and service-related parts not covered by the agreement; also, 10% off regular price of preventive maintenance check.
- Fast help by phone – phone support from a Sears technician on products requiring in-home repair, plus convenient repair scheduling.

Once you purchase the Agreement, a simple phone call is all that it takes for you to schedule service. You can call anytime day or night, or schedule a service appointment online.

Sears has over 12,000 professional repair specialists, who have access to over 4.5 million quality parts and accessories. That's the kind of professionalism you can count on to help prolong the life of your new purchase for years to come. Purchase your Repair Protection Agreement today! **Some limitations and exclusions apply. For prices and additional information call 1-800-827-6655.**

## SEARS INSTALLATION SERVICE

*For Sears professional installation of home appliances, garage door openers, water heaters, and other major home items, in the U.S.A. call 1-800-4-MY-HOME®*

# UNASSEMBLED PARTS

## Steering Wheel

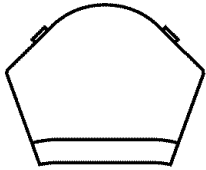

Steering Wheel Insert

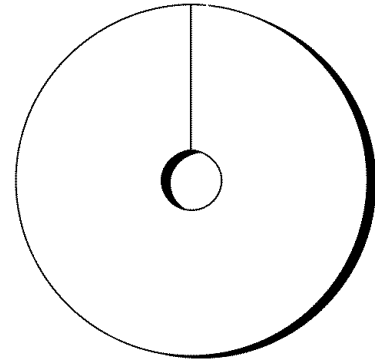
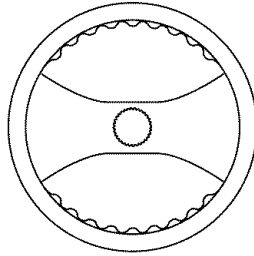

(1) Large Flat Washer

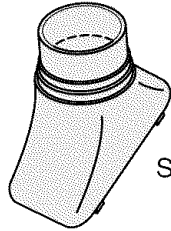

Steering Boot

(1) 5/16 Lock Washer



Steering Extension Shaft

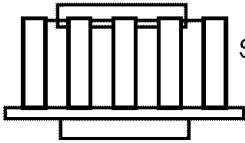

Steering Wheel Adapter

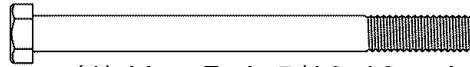

(1) Hex Bolt 5/16-18 x 4

## Seat

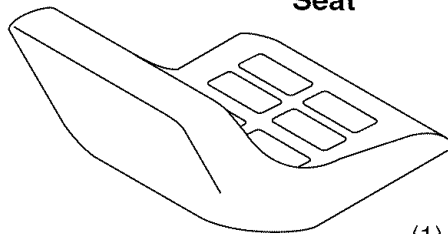

(1) Washer  
17/32 x 1-3/16 x 12 Gauge



(1) Knob

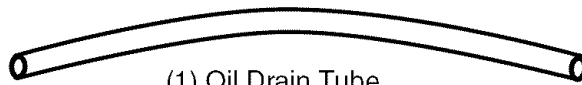

(1) Oil Drain Tube  
For Future Use

## Keys

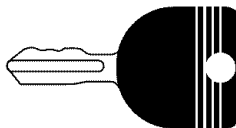

(2) Keys

## Slope Sheet

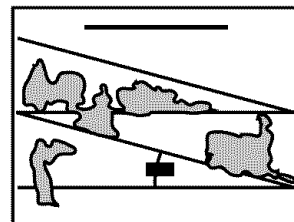

## ASSEMBLY/PRE-OPERATION

Your new tractor has been assembled at the factory with the exception of those parts left unassembled for shipping purposes. To ensure safe and proper operation of your tractor all parts and hardware you assemble must be tightened securely. Use the correct tools as necessary to insure proper tightness.

### TOOLS REQUIRED FOR ASSEMBLY

A socket wrench set will make assembly easier. Standard wrench sizes you need are listed below.

- (1) 3/4" wrench
- (1) Pliers
- (2) 7/16" wrench
- (1) Utility knife
- (1) Tire pressure gauge

When right or left hand is mentioned in this manual, it means when you are in the operating position (seated behind the steering wheel).

### TO REMOVE TRACTOR FROM CARTON

#### UNPACK CARTON

1. Remove all accessible loose parts and parts boxes from carton.
2. Cut along dotted lines on all four panels of carton. Remove end panels and lay side panels flat.
3. Check for any additional loose parts or cartons and remove.

### BEFORE REMOVING TRACTOR FROM SKID

#### ATTACH STEERING WHEEL

#### ASSEMBLE EXTENSION SHAFT AND BOOT

1. Slide extension shaft onto lower steering shaft.
2. Place tabs of steering boot over tab slots in dash and push down to secure.

#### INSTALL STEERING WHEEL

3. Position front wheels of the tractor so they are pointing straight forward.
4. Remove steering wheel adapter from steering wheel and slide adapter onto steering shaft extension.
5. Position steering wheel so cross bars are horizontal (left to right) and slide inside boot and onto adapter.
6. Assemble large flat washer, 5/16 lock washer, 5/16 hex bolt and tighten securely.
7. Snap steering wheel insert into center of steering wheel.
8. Remove protective materials from tractor hood and grill.

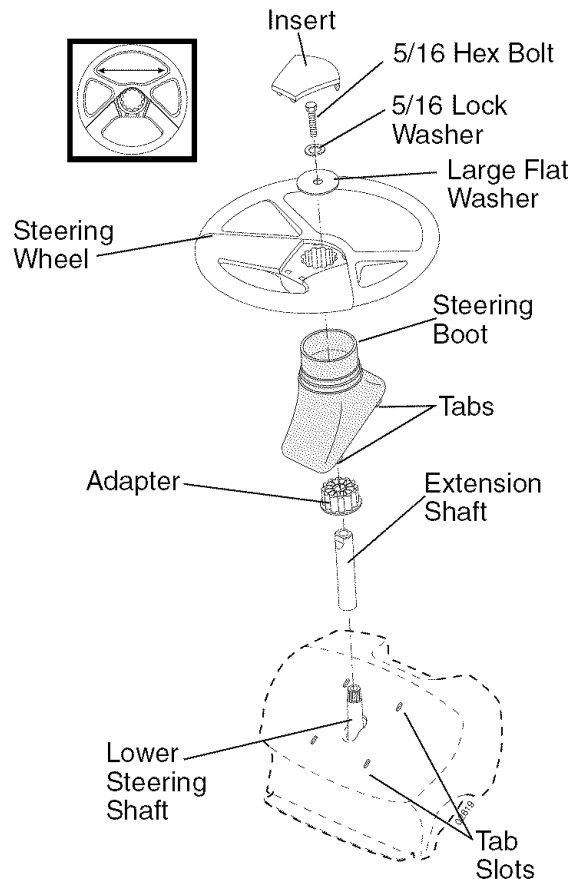

**IMPORTANT:** Check for and remove any staples in skid that may puncture tires where tractor is to roll off skid.

#### INSTALL SEAT

Adjust seat before tightening adjustment knob.

1. Remove adjustment knob and flat washer securing seat to cardboard packing and set aside for assembly of seat to tractor.
2. Pivot seat upward and remove from the cardboard packing. Remove the cardboard packing and discard.
3. Place seat on seat pan so head of shoulder bolt is positioned over large slotted hole in pan.
4. Push down on seat to engage shoulder bolt in slot and pull seat towards rear of tractor.



5. Pivot seat and pan forward and assemble adjustment knob and flat washer loosely. Do not tighten.
6. Lower seat into operating position and sit in seat.
7. Slide seat until a comfortable position is reached which allows you to press clutch/brake pedal all the way down.
8. Get off seat without moving its adjusted position.
9. Raise seat and tighten adjustment knob securely.

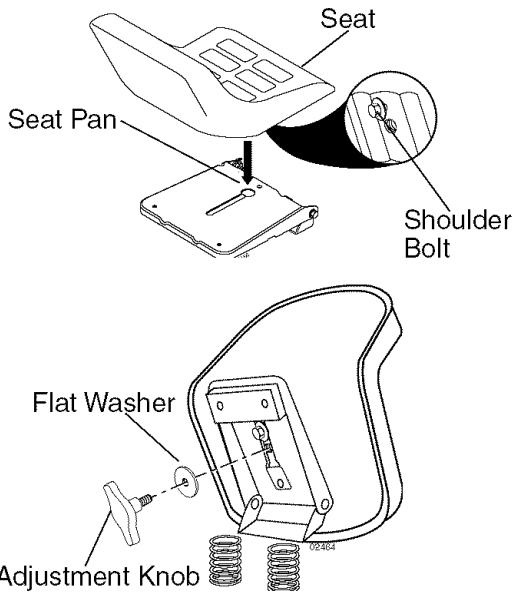

## CONNECT BATTERY

**CAUTION:** Do not short battery terminals by allowing a wrench or any other object to contact both terminals at the same time. Before connecting battery, remove metal bracelets, wristwatch bands, rings, etc.

Positive terminal must be connected first to prevent sparking from accidental grounding.

- Lift seat pan to raised position.
- Remove terminal protective caps and discard.
- If this battery is put into service after month and year indicated on label (label located between terminals) charge battery for minimum of one hour at 6-10 amps. (See "BATTERY" in the Maintenance section of this manual for charging instructions).
- First connect RED battery cable to positive (+) terminal with hex bolt and keps nut as shown. Tighten securely. Slide terminal cover over terminal.
- Connect BLACK grounding cable to negative (-) terminal with remaining hex bolt and keps nut. Tighten securely.

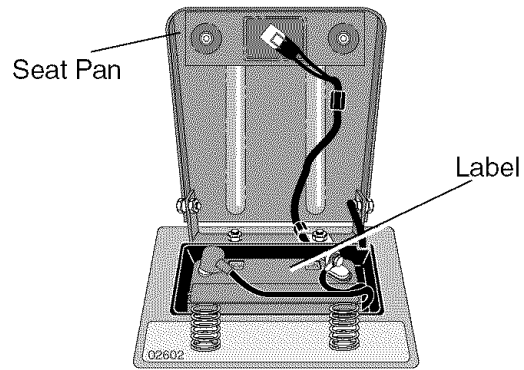
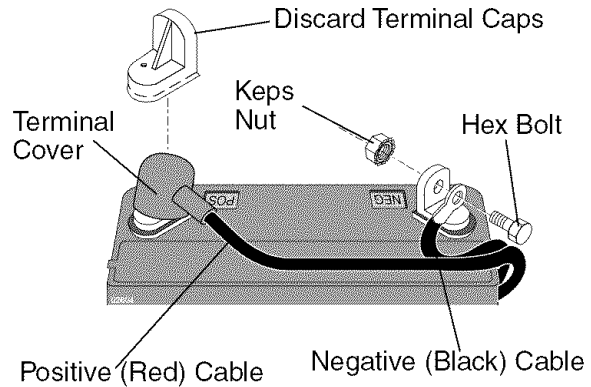

**NOTE:** You may now roll or drive your tractor off the skid. Follow the appropriate instruction below to remove the tractor from the skid.

## TO ROLL TRACTOR OFF SKID (See Operation section for location and function of controls)

1. Press lift lever plunger and raise attachment lift lever to its highest position.
2. Release parking brake by depressing clutch/brake pedal.
3. Place gearshift lever in neutral (N) position.
4. Roll tractor forward off skid.
5. Remove banding holding deflector shield up against tractor.

## **TO DRIVE TRACTOR OFF SKID (See Operation section for location and function of controls)**

**⚠ WARNING:** Before starting, read, understand and follow all instructions in the Operation section of this manual. Be sure tractor is in a well-ventilated area. Be sure the area in front of tractor is clear of other people and objects.

1. Be sure all the above assembly steps have been completed.
2. Check engine oil level and fill fuel tank with gasoline.
3. Sit on seat in operating position, depress clutch/brake pedal and set the parking brake.
4. Place gear shift lever in neutral (N) position.
5. Press lift lever plunger and raise attachment lift lever to its highest position.
6. Start the engine. After engine has started, move throttle control to idle position.
7. Depress clutch/brake pedal into full "BRAKE" position and hold. Move gearshift lever to 1st gear.
8. Slowly release clutch/brake pedal and slowly drive tractor off skid.
9. Apply brake to stop tractor, set parking brake and place gearshift lever in neutral position.
10. Turn ignition key to "STOP" position. Continue with the instructions that follow.

## **CHECK TIRE PRESSURE**

The tires on your tractor were overinflated at the factory for shipping purposes. Correct tire pressure is important for best cutting performance.

- Reduce tire pressure to PSI shown in "PRODUCT SPECIFICATIONS" section of this manual.

## **CHECK DECK LEVELNESS**

For best cutting results, mower housing should be properly leveled. See "TO LEVEL MOWER HOUSING" in the Service and Adjustments section of this manual.

## **CHECK FOR PROPER POSITION OF ALL BELTS**

See the figures that are shown for replacing motion and mower blade drive belts in the Service and Adjustments section of this manual. Verify that the belts are routed correctly.

## **CHECK BRAKE SYSTEM**

After you learn how to operate your tractor, check to see that the brake is properly adjusted. See "TO ADJUST BRAKE" in the Service and Adjustments section of this manual.

## **✓ CHECKLIST**

Before you operate and enjoy your new tractor, we wish to assure that you receive the best performance and satisfaction from this Quality Product.

Please review the following checklist:

- ✓ All assembly instructions have been completed.
- ✓ No remaining loose parts in carton.
- ✓ Battery is properly prepared and charged. (Minimum 1 hour at 6 amps).
- ✓ Seat is adjusted comfortably and tightened securely.
- ✓ All tires are properly inflated. (For shipping purposes, the tires were overinflated at the factory).
- ✓ Be sure mower deck is properly leveled side-to-side/front-to-rear for best cutting results. (Tires must be properly inflated for leveling).
- ✓ Check mower and drive belts. Be sure they are routed properly around pulleys and inside all belt keepers.
- ✓ Check wiring. See that all connections are still secure and wires are properly clamped.

While learning how to use your tractor, pay extra attention to the following important items:

- ✓ Engine oil is at proper level.
- ✓ Fuel tank is filled with fresh, clean, regular unleaded gasoline.
- ✓ Become familiar with all controls - their location and function. Operate them before you start the engine.
- ✓ Be sure brake system is in safe operating condition.

# OPERATION

These symbols may appear on your tractor or in literature supplied with the product. Learn and understand their meaning.

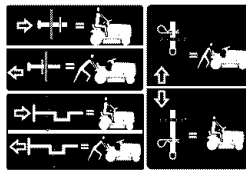
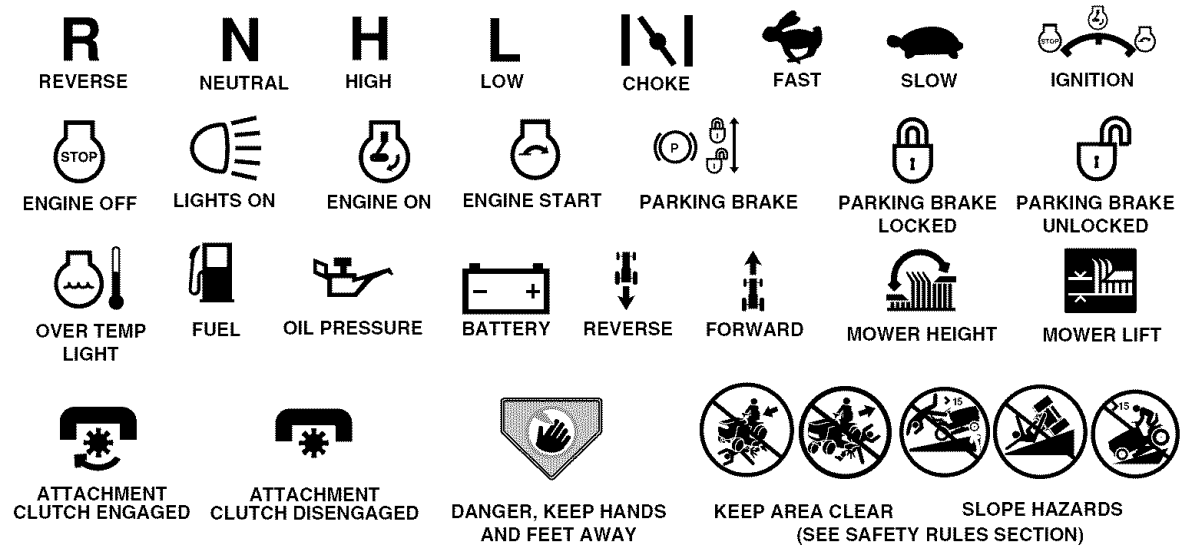

**FREE WHEEL**  
(Automatic Models only)



Failure to follow instructions could result in serious injury or death. The safety alert symbol is used to identify safety information about hazards which can result in death, serious injury and/or property damage.



**DANGER** indicates a hazard which, if not avoided, will result in death or serious injury.



**WARNING** indicates a hazard which, if not avoided, could result in death or serious injury.



**CAUTION** indicates a hazard which, if not avoided, might result in minor or moderate injury.

**CAUTION** when used **without** the alert symbol, indicates a situation that **could result in damage to the tractor and/or engine.**



**HOT SURFACES** indicates a hazard which, if not avoided, **could result in death, serious injury and/or property damage.**



**FIRE** indicates a hazard which, if not avoided, **could result in death, serious injury and/or property damage.**

## KNOW YOUR TRACTOR

### READ THIS OWNER'S MANUAL AND SAFETY RULES BEFORE OPERATING YOUR TRACTOR

Compare the illustrations with your tractor to familiarize yourself with the locations of various controls and adjustments. Save this manual for future reference.

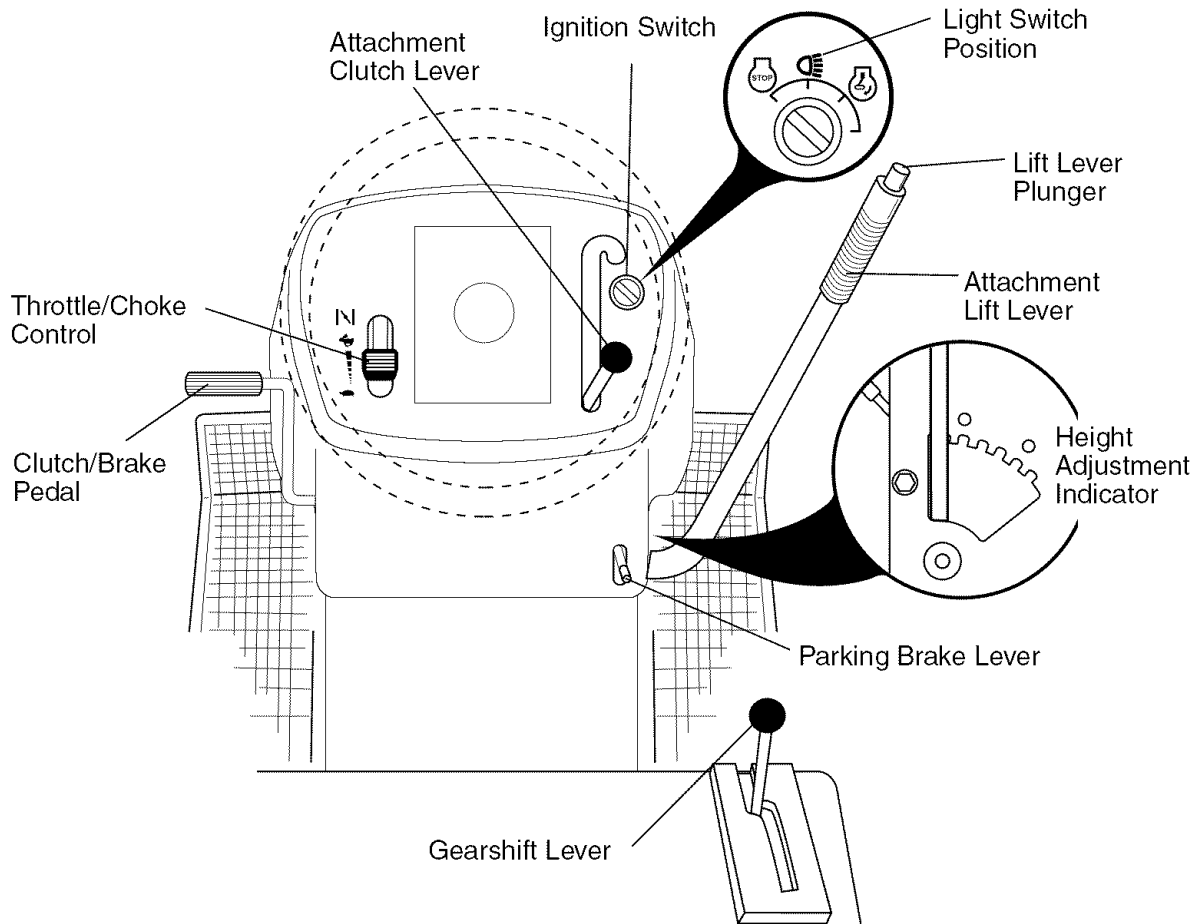

---

Our tractors conform to the safety standards of the American National Standards Institute.

---

**ATTACHMENT CLUTCH LEVER** - Used to engage the mower blades, or other attachments mounted to your tractor.

**ATTACHMENT LIFT LEVER** - Used to raise, lower, and adjust the mower deck or other attachments mounted to your tractor.

**CLUTCH/BRAKE PEDAL** - Used for declutching and braking the tractor and starting the engine.

**GEARSHIFT LEVER** - Selects the speed and direction of tractor.

**IGNITION SWITCH** - Used for starting and stopping the engine.

**LIFT LEVER PLUNGER** - Used to release attachment lift lever when changing its position.

**LIGHT SWITCH POSITION** - Turns the headlights on and off.

**PARKING BRAKE LEVER** - Locks clutch/brake pedal into the brake position.

**THROTTLE/CHOKE CONTROL** - Used for starting and controlling engine speed.



The operation of any tractor can result in foreign objects thrown into the eyes, which can result in severe eye damage. Always wear safety glasses or eye shields while operating your tractor or performing any adjustments or repairs. We recommend a wide vision safety mask over spectacles or standard safety glasses.

## HOW TO USE YOUR TRACTOR TO SET PARKING BRAKE

Your tractor is equipped with an operator presence sensing switch. When engine is running, any attempt by the operator to leave the seat without first setting the parking brake will shut off the engine.

1. Depress clutch/brake pedal all the way down and hold.
2. Pull parking brake lever up and release pressure from clutch/brake pedal. Pedal should remain in brake position. Make sure parking brake will hold tractor secure.

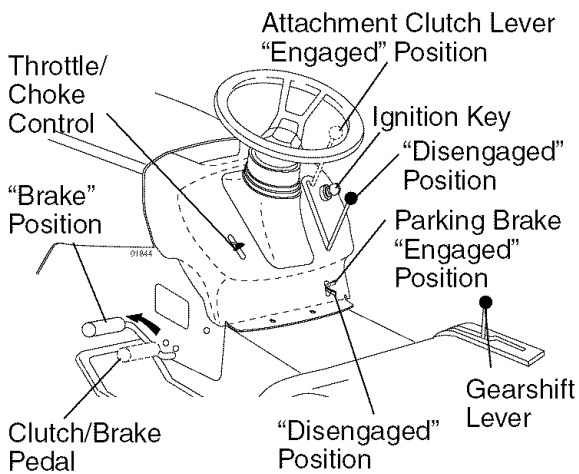

## STOPPING

### MOWER BLADES -

- To stop mower blades, move attachment clutch lever to "DISENGAGED" position.

### GROUND DRIVE -

- To stop ground drive, depress clutch/brake pedal all the way down.
- Move gearshift lever to neutral (N) position.

### ENGINE -

- Move throttle control between half and full speed (fast) position.

**NOTE:** Failure to move throttle control between half and full speed (fast) position, before stopping, may cause engine to "backfire".

- Turn ignition key to "STOP" position and remove key. Always remove key when leaving tractor to prevent unauthorized use.
- Never use choke to stop engine.

**IMPORTANT:** Leaving the ignition switch in any position other than "STOP" will cause the battery to discharge and go dead.

**NOTE:** Under certain conditions when tractor is standing idle with the engine running, hot engine exhaust gases may cause "browning" of grass. To eliminate this possibility, always stop engine when stopping tractor on grass areas.

**CAUTION:** Always stop tractor completely, as described above, before leaving the operator's position.

## TO USE THROTTLE CONTROL

Always operate engine at full throttle.

- Operating engine at less than full throttle reduces the battery charging rate.
- Full throttle offers the best bagging and mower performance.

## TO MOVE FORWARD AND BACKWARD

The direction and speed of movement is controlled by the gearshift lever.

1. Start tractor with clutch/brake pedal depressed and gearshift lever in neutral (N) position.
2. Move gearshift lever to desired position.
3. Slowly release clutch/brake pedal to start movement.

**IMPORTANT:** Bring tractor to a complete stop before shifting or changing gears. Failure to do so will shorten the useful life of your transaxle.

## TO ADJUST MOWER CUTTING HEIGHT

The position of the attachment lift lever determines the cutting height.

- Grasp lift lever.
- Press plunger with thumb and move lever to desired position.

The cutting height range is approximately 1-1/2 to 4". The heights are measured from the ground to the blade tip with the engine not running. These heights are approximate and may vary depending upon soil conditions, height of grass and types of grass being mowed.

- The average lawn should be cut to approximately 2-1/2 inches during the cool season and to over 3 inches during hot months. For healthier and better looking lawns, mow often and after moderate growth.
- For best cutting performance, grass over 6 inches in height should be mowed twice. Make the first cut relatively high; the second to desired height.

## TO OPERATE MOWER

Your tractor is equipped with an operator presence sensing switch. Any attempt by the operator to leave the seat with the engine running and the attachment clutch engaged will shut off the engine. You must remain fully and centrally positioned in the seat to prevent the engine from hesitating or cutting off when operating your equipment on rough, rolling terrain or hills.

1. Select desired height of cut.
2. Start mower blades by engaging attachment clutch control.

TO STOP MOWER BLADES - disengage attachment clutch control.

**CAUTION:** Do not operate the mower without either the entire grass catcher, on mowers so equipped, or the deflector shield in place.

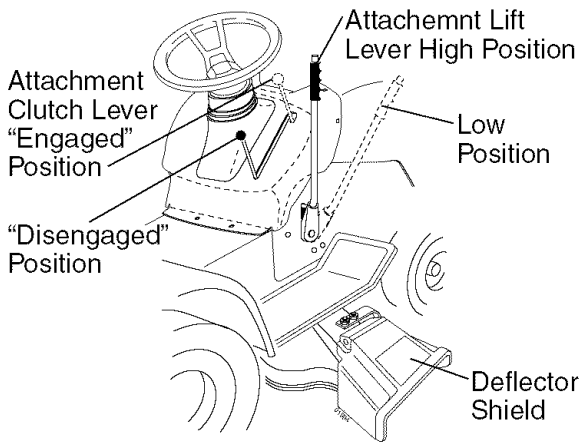

## TO OPERATE ON HILLS

**WARNING:** Do not drive up or down hills with slopes greater than 15° and do not drive across any slope. Use the slope guide at the back of this manual.

- Choose the slowest speed before starting up or down hills.
- Avoid stopping or changing speed on hills.

- If slowing is necessary, move throttle control lever to slower position.
- If stopping is absolutely necessary, push clutch/brake pedal quickly to brake position and engage parking brake.
- Move gearshift lever to 1st gear. Be sure you have allowed room for tractor to roll slightly as you restart movement.
- To restart movement, slowly release parking brake and clutch/brake pedal.
- Make all turns slowly.

## TO TRANSPORT

- Raise attachment lift to highest position with attachment lift control.
- When pushing or towing your tractor, be sure gearshift lever is in neutral (N) position.
- Do not push or tow tractor at more than five (5) MPH.

**NOTE:** To protect hood from damage when transporting your tractor on a truck or a trailer, be sure hood is closed and secured to tractor. Use an appropriate means of tying hood to tractor (rope, cord, etc.).

## TOWING CARTS AND OTHER ATTACHMENTS

Tow only the attachments that are recommended by and comply with specifications of the manufacturer of your tractor. Use common sense when towing. Too heavy of a load, while on a slope, is dangerous. Tires can lose traction with the ground and cause you to lose control of your tractor.

## BEFORE STARTING THE ENGINE CHECK ENGINE OIL LEVEL

The engine in your tractor has been shipped, from the factory, already filled with summer weight oil.

1. Check engine oil with tractor on level ground.
  2. Remove oil fill cap/dipstick and wipe clean, reinsert the dipstick and screw cap tight, wait for a few seconds, remove and read oil level. If necessary, add oil until "FULL" mark on dipstick is reached. Do not overfill.
- For cold weather operation you should change oil for easier starting (See the oil viscosity chart in the Maintenance section of this manual).
  - To change engine oil, see the Maintenance section in this manual.

## ADD GASOLINE

- Fill fuel tank to bottom of filler neck. Do not overfill. Use fresh, clean, regular unleaded gasoline with a minimum of 87 octane. (Use of leaded gasoline will increase carbon and lead oxide deposits and reduce valve life). Do not mix oil with gasoline. Purchase fuel in quantities that can be used within 30 days to assure fuel freshness.

 **CAUTION:** Wipe off any spilled oil or fuel. Do not store, spill or use gasoline near an open flame.

**IMPORTANT:** When operating in temperatures below 32°F (0°C), use fresh, clean winter grade gasoline to help insure good cold weather starting.

**CAUTION:** Alcohol blended fuels (called gasohol or using ethanol or methanol) can attract moisture which leads to separation and formation of acids during storage. Acidic gas can damage the fuel system of an engine while in storage. To avoid engine problems, the fuel system should be emptied before storage of 30 days or longer. Drain the gas tank, start the engine and let it run until the fuel lines and carburetor are empty. Use fresh fuel next season. See Storage Instructions for additional information. Never use engine or carburetor cleaner products in the fuel tank or permanent damage may occur.

## TO START ENGINE

When starting the engine for the first time or if the engine has run out of fuel, it will take extra cranking time to move fuel from the tank to the engine.

1. Sit on seat in operating position, depress clutch/brake pedal and set parking brake.
2. Place gear shift lever in neutral (N) position.
3. Move attachment clutch to disengaged position.
4. Move throttle control to choke position.

**NOTE:** Before starting, read the warm and cold starting procedures below.

5. Insert key into ignition and turn key clockwise to start position and release key as soon as engine starts. Do not run starter continuously for more than fifteen seconds per minute. If the engine does not start after several attempts, move throttle control to fast position, wait a few minutes and try again. If engine still does not start, move the throttle control back to the choke position and retry.

**WARM WEATHER STARTING (50° F and above)**

6. When engine starts, move the throttle control to the fast position.
- The attachments and ground drive can now be used. If the engine does not accept the load, restart the engine and allow it to warm up for one minute using the choke as described above.

**COLD WEATHER STARTING ( 50° F and below)**

6. When engine starts, leave throttle control in choke position until engine warms up and begins to run roughly. Once rough running begins, immediately move the throttle control to the fast position. Engine warm-up may take from several seconds to several minutes (the colder the temperature, the longer the warm-up).
- The attachments can also be used during the engine warm-up period.

**NOTE:** If at a high altitude (above 3000 feet) or in cold temperatures (below 32 F) the carburetor fuel mixture may need to be adjusted for best engine performance (see "TO ADJUST CARBURETOR" in the Service and Adjustments section of this manual).

## MOWING TIPS

- Mower should be properly leveled for best mowing performance. See “TO LEVEL MOWER HOUSING” in the Service and Adjustments section of this manual.
  - The left hand side of mower should be used for trimming.
  - Drive so that clippings are discharged onto the area that has already been cut. Have the cut area to the right of the tractor. This will result in a more even distribution of clippings and more uniform cutting.
  - When mowing large areas, start by turning to the right so that clippings will discharge away from shrubs, fences, driveways, etc. After one or two rounds, mow in the opposite direction making left hand turns until finished.
- If grass is extremely tall, it should be mowed twice to reduce load and possible fire hazard from dried clippings. Make first cut relatively high; the second to the desired height.
  - Do not mow grass when it is wet. Wet grass will plug mower and leave undesirable clumps. Allow grass to dry before mowing.
  - **Always operate engine at full throttle when mowing** to assure better mowing performance and proper discharge of material. Regulate ground speed by selecting a low enough gear to give the mower cutting performance as well as the quality of cut desired.
  - When operating attachments, select a ground speed that will suit the terrain and give best performance of the attachment being used.

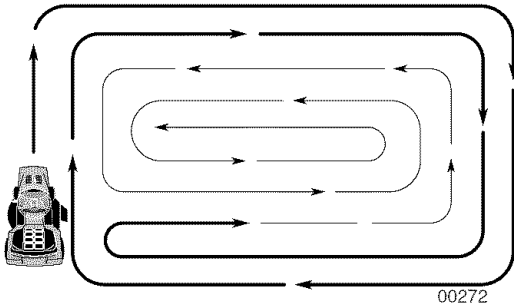



# MAINTENANCE

MAINTENANCE SCHEDULE		BEFORE EACH USE					SERVICE DATES			
FILL IN DATES AS YOU COMPLETE REGULAR SERVICE		BEFORE EACH USE	EVERY 8 HOURS	EVERY 25 HOURS	EVERY 50 HOURS	EVERY 100 HOURS	EVERY SEASON	BEFORE STORAGE		
<b>T R A C T O R</b>	Check Brake Operation	✓	✓							
	Check Tire Pressure	✓	✓							
	Check Operator Presence and Interlock Systems	✓								
	Check for Loose Fasteners	✓				✓ <sub>5</sub>	✓			
	Sharpen/Replace Mower Blades			✓ <sub>3</sub>						
	Lubrication Chart			✓ <sub>3</sub>			✓			
	Check Battery Level			✓ <sub>4</sub>						
	Clean Battery and Terminals			✓			✓			
	Check Transaxle Cooling			✓						
	Check V-Belts					✓				
<b>E N G I N E</b>	Check Engine Oil Level	✓	✓							
	Change Engine Oil (with oil filter)				✓ <sub>1,2</sub>		✓			
	Change Engine Oil (without oil filter)			✓ <sub>1,2</sub>			✓			
	Clean Air Filter			✓ <sub>2</sub>						
	Clean Air Screen			✓ <sub>2</sub>						
	Inspect Muffler/Spark Arrester				✓					
	Replace Oil Filter (If equipped)					✓ <sub>1,2</sub>				
	Clean Engine Cooling Fins					✓ <sub>2</sub>				
	Replace Spark Plug					✓	✓			
	Replace Air Filter Paper Cartridge					✓ <sub>2</sub>				
	Replace Fuel Filter						✓			

1 - Change more often when operating under a heavy load or in high ambient temperatures.  
 2 - Service more often when operating in dirty or dusty conditions.

3 - Replace blades more often when mowing in sandy soil.  
 4 - Not required if equipped with maintenance-free battery.  
 5 - Tighten front axle pivot bolt to 35 ft.-lbs. maximum. Do not overtighten.

## GENERAL RECOMMENDATIONS

The warranty on this tractor does not cover items that have been subjected to operator abuse or negligence. To receive full value from the warranty, operator must maintain tractor as instructed in this manual.

Some adjustments will need to be made periodically to properly maintain your tractor.

At least once a season, check to see if you should make any of the adjustments described in the Service and Adjustments section of this manual.

- At least once a year you should replace the spark plug, clean or replace air filter, and check blades and belts for wear. A new spark plug and clean air filter assure proper air-fuel mixture and help your engine run better and last longer.

## BEFORE EACH USE

- Check engine oil level.
- Check brake operation.
- Check tire pressure.
- Check operator presence and interlock systems for proper operation.
- Check for loose fasteners.

## LUBRICATION CHART

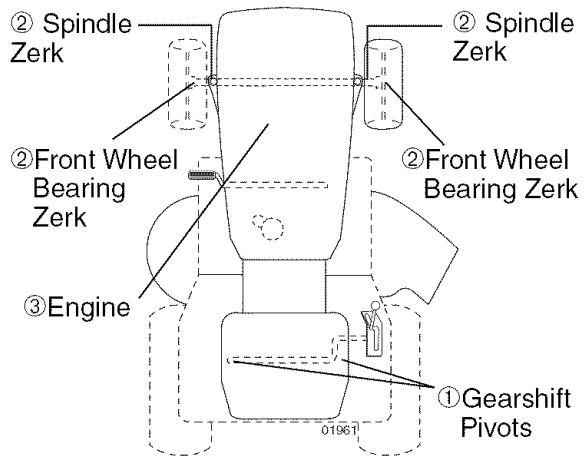

- SAE 30 or 10w30 Motor Oil
- General Purpose Grease
- Refer to Maintenance "ENGINE" Section

**IMPORTANT:** Do not oil or grease the pivot points which have special nylon bearings. Viscous lubricants will attract dust and dirt that will shorten the life of the self-lubricating bearings. If you feel they must be lubricated, use only a dry, powdered graphite type lubricant sparingly.

## TRACTOR

Always observe safety rules when performing any maintenance.

### BRAKE OPERATION

If tractor requires more than five (5) feet to stop at highest speed in highest gear on a level, dry concrete or paved surface, then brake must be checked and adjusted. (See "TO ADJUST BRAKE" in the Service and Adjustments section of this manual).

### TIRES

- Maintain proper air pressure in all tires (See "PRODUCT SPECIFICATIONS" section of this manual).
- Keep tires free of gasoline, oil, or insect control chemicals which can harm rubber.
- Avoid stumps, stones, deep ruts, sharp objects and other hazards that may cause tire damage.

**NOTE:** To seal tire punctures and prevent flat tires due to slow leaks, tire sealant may be purchased from your local parts dealer. Tire sealant also prevents tire dry rot and corrosion.

### OPERATOR PRESENCE SYSTEM

Be sure operator presence and interlock systems are working properly. If your tractor does not function as described, repair the problem immediately.

- The engine should not start unless the clutch/brake pedal is fully depressed and attachment clutch control is in the disengaged position.
- When the engine is running, any attempt by the operator to leave the seat without first setting the parking brake should shut off the engine.
- When the engine is running and the attachment clutch is engaged, any attempt by the operator to leave the seat should shut off the engine.
- The attachment clutch should never operate unless the operator is in the seat.

### BLADE CARE

For best results mower blades must be kept sharp. Replace bent or damaged blades.

### BLADE REMOVAL

1. Raise mower to highest position to allow access to blades.
2. Remove blade bolt, lock washer and flat washer securing blade.
3. Install new or resharpened blade with trailing edge up towards deck as shown.

**IMPORTANT:** To ensure proper assembly, center hole in blade must align with star on mandrel assembly.

4. Reassemble blade bolt, lock washer and flat washer in exact order as shown.
5. Tighten blade bolt securely (27-35 Ft. Lbs. torque).

**IMPORTANT:** Blade bolt is heat treated. If bolt needs replacing, replace only with approve bolt shown in the Repair Parts.

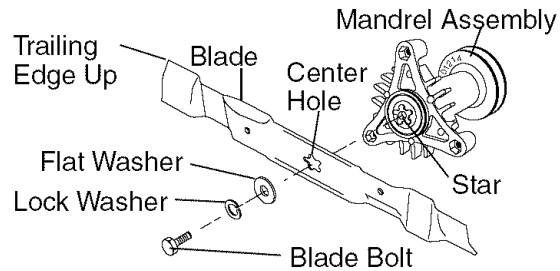

### TO SHARPEN BLADE

**NOTE:** We do not recommend sharpening blade - but if you do, be sure the blade is balanced.

Care should be taken to keep the blade balanced. An unbalanced blade will cause excessive vibration and eventual damage to mower and engine.

- The blade can be sharpened with a file or on a grinding wheel. Do not attempt to sharpen while on the mower.
- To check blade balance, you will need a 5/8" diameter steel bolt, pin, or a cone balancer. (When using a cone balancer, follow the instructions supplied with balancer.)

**NOTE:** Do not use a nail for balancing blade. The lobes of the center hole may appear to be centered, but are not.

- Slide blade on to an unthreaded portion of the steel bolt or pin and hold the bolt or pin parallel with the ground. If blade is balanced, it should remain in a horizontal position. If either end of the blade moves downward, sharpen the heavy end until the blade is balanced.

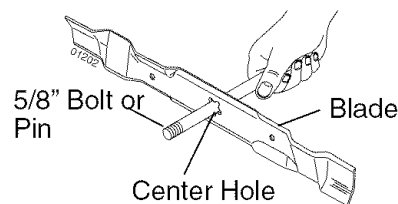

### BATTERY

Your tractor has a battery charging system which is sufficient for normal use. However, periodic charging of the battery with an automotive charger will extend its life.

- Keep battery and terminals clean.
- Keep battery bolts tight.
- Keep small vent holes open.
- Recharge at 6-10 amperes for 1 hour.

**NOTE:** The original equipment battery on your tractor is maintenance free. Do not attempt to open or remove caps or covers. Adding or checking level of electrolyte is not necessary.

#### TO CLEAN BATTERY AND TERMINALS

Corrosion and dirt on the battery and terminals can cause the battery to “leak” power.

1. Disconnect BLACK battery cable first then RED battery cable and remove battery from tractor.
2. Rinse the battery with plain water and dry.
3. Clean terminals and battery cable ends with wire brush until bright.
4. Coat terminals with grease or petroleum jelly.
5. Reinstall battery (See “REPLACING BATTERY” in the SERVICE AND ADJUSTMENTS section of this manual).

#### TRANSAXLE COOLING

Keep transaxle free from build-up of dirt and chaff which can restrict cooling.

#### V-BELTS

Check V-belts for deterioration and wear after 100 hours of operation and replace if necessary. The belts are not adjustable. Replace belts if they begin to slip from wear.

#### ENGINE

##### LUBRICATION

Only use high quality detergent oil rated with API service classification SG-SL. Select the oil’s SAE viscosity grade according to your expected operating temperature.

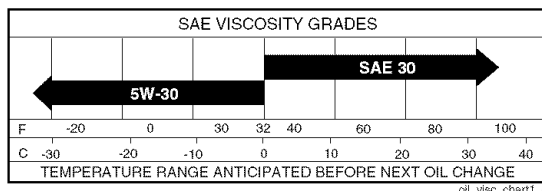

**NOTE:** Although multi-viscosity oils (5W30, 10W30 etc.) improve starting in cold weather, the oils will result in increased oil consumption when used above 32°F. Check your engine oil level more frequently to avoid possible engine damage from running low on oil.

Change the oil after every 25 hours of operation or at least once a year if the tractor is not used for 25 hours in one year. Check the crankcase oil level before starting the engine and after each eight (8)

hours of operation. Tighten oil fill cap/dipstick securely each time you check the oil level.

#### TO CHANGE ENGINE OIL

Determine temperature range expected before oil change. All oil must meet API service classification SG-SL.

- Be sure tractor is on level surface.
  - Oil will drain more freely when warm.
  - Catch oil in a suitable container.
1. Remove oil fill cap/dipstick. Be careful not to allow dirt to enter the engine when changing oil.
  2. Remove yellow cap from end of drain valve and install the drain tube onto the fitting.

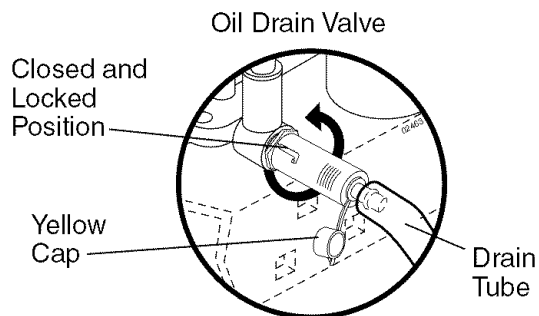

3. Unlock drain valve by pushing inward slightly and turning counterclockwise.
4. To open, pull out on the drain valve.
5. After oil has drained completely, close and lock the drain valve by pushing inward and turning clockwise until the pin is in the locked position as shown.
6. Remove the drain tube and replace the cap onto the end of the drain valve.
7. Refill engine with oil through oil fill dipstick tube. Pour slowly. Do not overfill. For approximate capacity see “PRODUCT SPECIFICATIONS” section of this manual.
8. Use gauge on oil fill cap/dipstick for checking level. For accurate reading, tighten dipstick cap securely onto the tube before removing dipstick. Keep oil at “FULL” line on dipstick. Tighten cap onto the tube securely when finished.

#### ENGINE OIL FILTER

Replace the engine oil filter every season or every other oil change if the tractor is used more than 100 hours in one year.

#### AIR FILTER

Your engine will not run properly using a dirty air filter. Replace pre-cleaner after every 25 hours of operation or every season. Service paper cartridge every 100 hours of operation or every season,

whichever occurs first.  
Service air cleaner more often under dusty conditions.

1. Pull up on air filter cover handle and rotate towards engine.
2. Remove cover.
3. Carefully remove air filter cartridge and pre-cleaner from base.
4. Clean base carefully to prevent debris from falling into carburetor.

**NOTE:** If very dirty or damaged, replace cartridge.

5. Place new pre-cleaner and cartridge firmly in base.
6. Align tabs on cover with slots in blower housing and replace cover.
7. Hook handle on cover and push down on handle to close.

**IMPORTANT:** Petroleum solvents, such as kerosene, are not to be used to clean the cartridge. They may cause deterioration of the cartridge. Do not oil cartridge. Do not use pressurized air to clean cartridge.

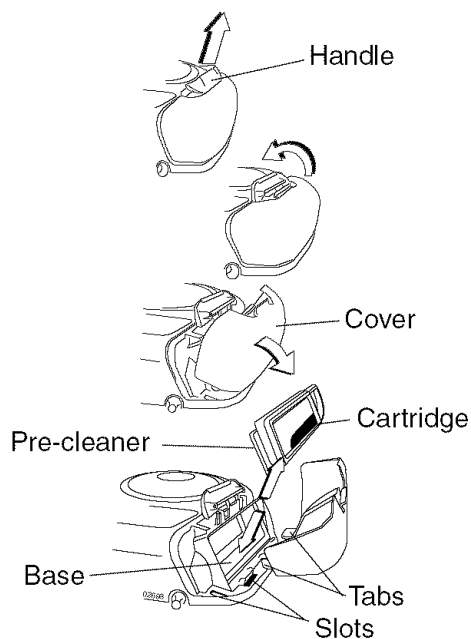

### CLEAN AIR SCREEN

Air screen must be kept free of dirt and chaff to prevent engine damage from overheating. Clean with a wire brush or compressed air to remove dirt and stubborn dried gum fibers.

### ENGINE COOLING SYSTEM

Debris may clog the engine's air cooling system. Remove blower housing and clean area shown to prevent overheating and engine damage.

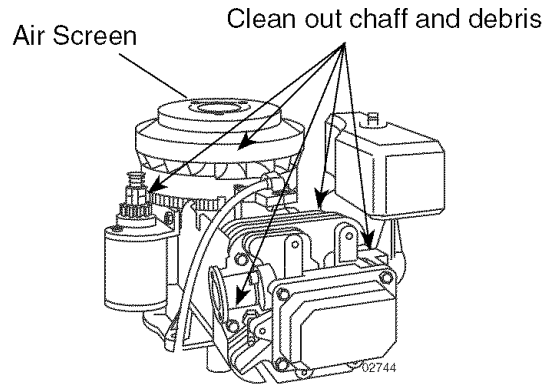

### MUFFLER

Inspect and replace corroded muffler and spark arrester (if equipped) as it could create a fire hazard and/or damage.

### SPARK PLUG(S)

Replace spark plug(s) at the beginning of each mowing season or after every 100 hours of operation, whichever occurs first. Spark plug type and gap setting are shown in "PRODUCT SPECIFICATIONS" section of this manual.

### IN-LINE FUEL FILTER

The fuel filter should be replaced once each season. If fuel filter becomes clogged, obstructing fuel flow to carburetor, replacement is required.

1. With engine cool, remove filter and plug fuel line sections.
2. Place new fuel filter in position in fuel line with arrow pointing towards carburetor.
3. Be sure there are no fuel line leaks and clamps are properly positioned.
4. Immediately wipe up any spilled gasoline.

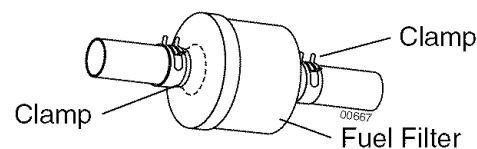

### CLEANING

- Clean engine, battery, seat, finish, etc. of all foreign matter.
- Keep finished surfaces and wheels free of all gasoline, oil, etc.
- Protect painted surfaces with automotive type wax.

We do not recommend using a garden hose or pressure washer to clean your tractor unless the engine and transmission are covered to keep water out. Water in engine or transmission will shorten the useful life of your tractor. Use compressed air or a leaf blower to remove grass, leaves and trash from tractor and mower.

# SERVICE AND ADJUSTMENTS



## WARNING: TO AVOID SERIOUS INJURY, BEFORE PERFORMING ANY SERVICE OR ADJUSTMENTS:

1. Depress clutch/brake pedal fully and set parking brake.
2. Place gearshift lever in neutral (N) position.
3. Place attachment clutch in "DISENGAGED" position.
4. Turn ignition key to "STOP" and remove key.
5. Make sure the blades and all moving parts have completely stopped.
6. Disconnect spark plug wire from spark plug and place wire where it cannot come in contact with plug.

## TRACTOR

### TO REMOVE MOWER

Mower will be easier to remove from the right side of tractor.

1. Place attachment clutch in "DISENGAGED" position.
2. Move attachment lift lever forward to lower mower to its lowest position.
3. Roll belt off engine pulley.
4. Remove small retainer spring, and remove clutch spring off pulley bolt.
5. Remove large retainer spring, slide collar off and push housing guide out of bracket.
6. Disconnect anti-sway bar from chassis bracket by removing retainer spring.

7. Disconnect suspension arms from rear deck brackets by removing retainer springs.
8. Disconnect front links from deck by removing retainer springs.
9. Raise lift lever to raise suspension arms. Slide mower out from under tractor.

**IMPORTANT:** If an attachment other than the mower deck is to be mounted on the tractor, remove the front links and hook the clutch spring into square hole in frame.

### TO INSTALL MOWER

1. Raise attachment lift lever to its highest position.

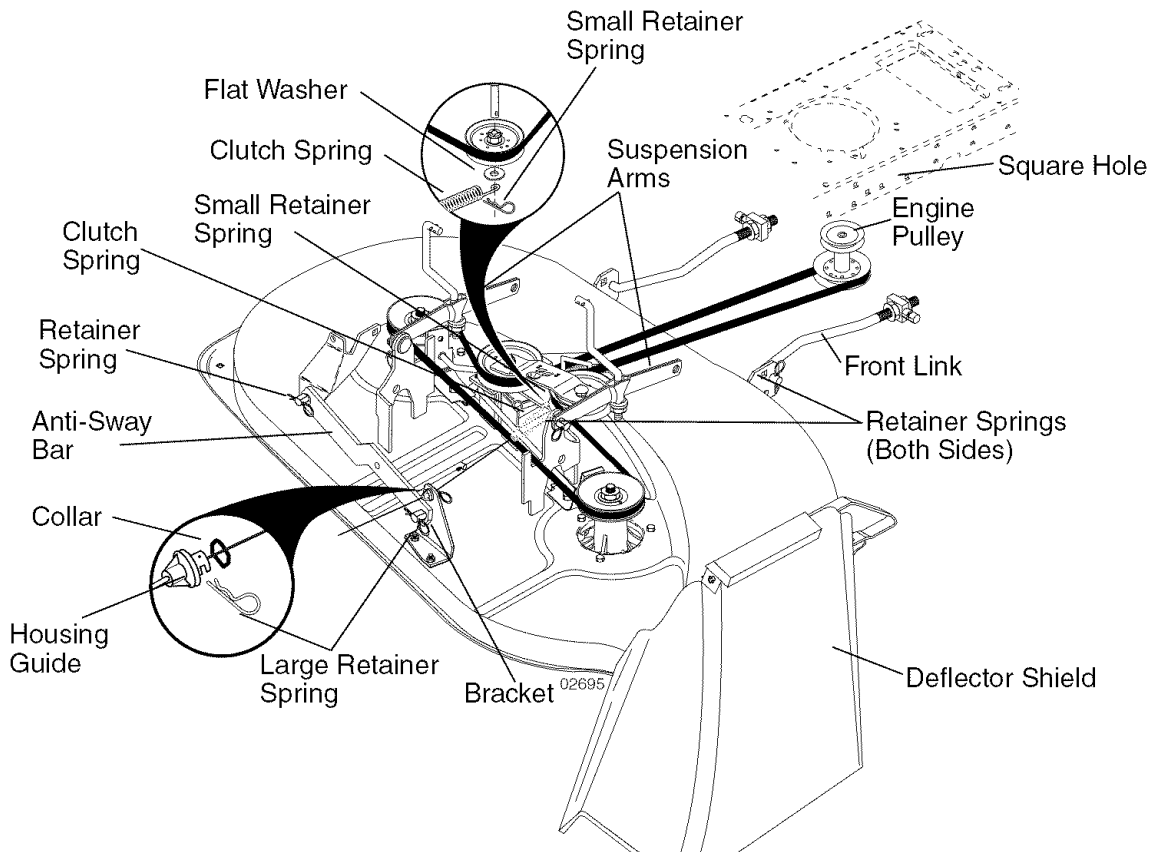

2. Slide mower under tractor with deflector shield to right side of tractor.
3. Lower lift lever to its lowest position.
4. Connect front links to mower deck and secure with retainer springs.
5. Connect suspension arms to rear deck brackets and secure with retainer springs.
6. Connect anti-sway bar to chassis bracket and secure with retainer spring.
7. Push clutch cable housing guide into bracket, slide collar onto guide and secure with large retainer spring.
8. Place flat washer and clutch spring on idler pulley bolt and secure with small retainer spring.
9. Install belt onto engine pulley.

### TO LEVEL MOWER HOUSING

Adjust the mower while tractor is parked on level ground or driveway. Make sure tires are properly inflated (See "PRODUCT SPECIFICATIONS" section of this manual). If tires are over or underinflated, you will not properly adjust your mower.

#### SIDE-TO-SIDE ADJUSTMENT

- Raise mower to its highest position.
- At the midpoint of both sides of mower, measure height from bottom edge of mower to ground. Distance "A" on both sides of mower should be the same or within 1/4" of each other.
- If adjustment is necessary, make adjustment on one side of mower only.
- To raise one side of mower, tighten lift link adjustment nut on that side.
- To lower one side of mower, loosen lift link adjustment nut on that side.

**NOTE:** Each full turn of adjustment nut will change mower height about 1/8".

- Recheck measurements after adjusting.

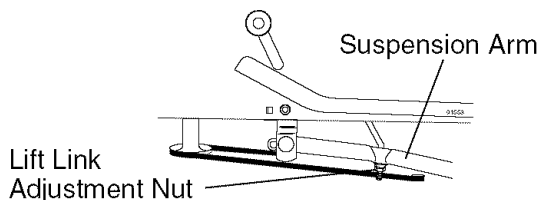
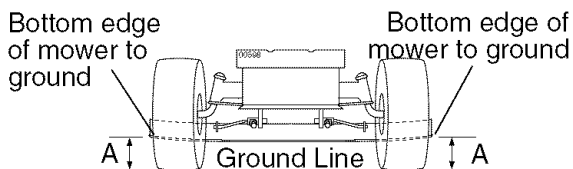

#### FRONT-TO-BACK ADJUSTMENT

**IMPORTANT:** Deck must be level side-to-side. If the following front-to-back adjustment is necessary, be sure to adjust both front links equally so mower will stay level side-to-side.

To obtain the best cutting results, the mower housing should be adjusted so that the front is approximately 1/8" to 1/2" lower than the rear when the mower is in its highest position.

Check adjustment on right side of tractor. Measure distance "D" directly in front and behind the mandrel at bottom edge of mower housing as shown.

- Before making any necessary adjustments, check that both front links are equal in length.
- If links are not equal in length, adjust one link to same length as other link.
- To lower front of mower loosen nut "E" on both front links an equal number of turns.
- When distance "D" is 1/8" to 1/2" lower at front than rear, tighten nuts "F" against trunnion on both front links.
- To raise front of mower, loosen nut "F" from trunnion on both front links. Tighten nut "E" on both front links an equal number of turns. The two front links must remain equal in length.
- When distance "D" is 1/8" to 1/2" lower at front than rear, tighten nut "F" against trunnion on both front links.
- Recheck side-to-side adjustment.

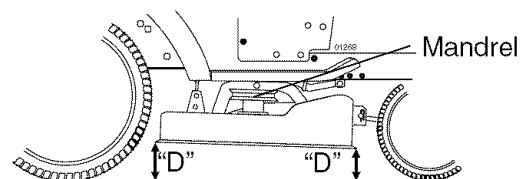

Both Front Links Should be Equal in Length

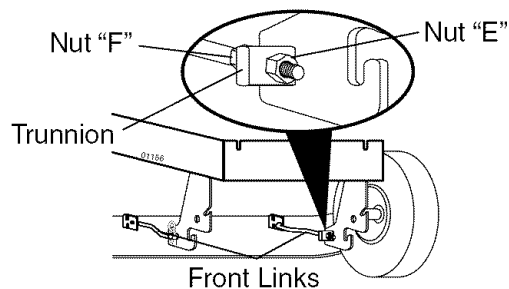
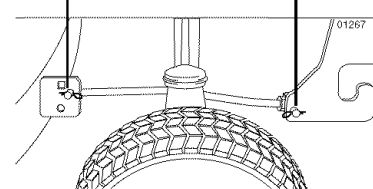

### TO REPLACE MOWER BLADE DRIVE BELT

The mower blade drive belt may be replaced without tools. Park the tractor on level surface. Engage parking brake.

## BELT REMOVAL -

1. Place attachment clutch in "DISENGAGED" position.
2. Move attachment lift lever forward to lower mower to its lowest position.
3. Roll belt off engine pulley.
4. Disconnect R.H. suspension arm from rear deck bracket by removing retainer spring.
5. Work belt off both mandrel pulleys and idler pulleys.
6. Pull belt away from mower.

## BELT INSTALLATION -

1. Work new belt around both mandrel pulleys and idler pulleys.
2. Install new belt into engine pulley groove.
3. Reconnect R.H. suspension arm and secure with retainer spring.
4. Make sure belt is in all pulley grooves and inside all belt guides.

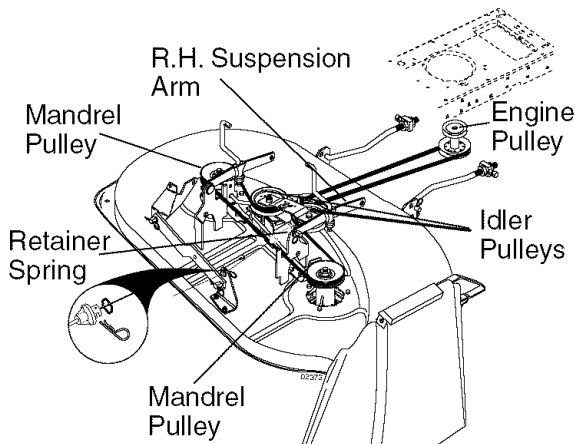

## TO CHECK AND ADJUST BRAKE

Your tractor is equipped with an adjustable brake system which is mounted on the right side of the transaxle.

If tractor requires more than five (5) feet to stop at highest speed in highest gear on a level, dry concrete or paved surface, then brake must be checked and adjusted.

## TO CHECK BRAKE

1. Park tractor on a level, dry concrete or paved surface, depress clutch/brake pedal all the way down and engage parking brake.
2. Place gear shift lever in neutral (N) position.

The rear wheels must lock and skid when you try to manually push the tractor forward. If the rear wheels rotate, the brake needs to be adjusted or the pads need to be replaced.

## TO ADJUST BRAKE

1. Depress clutch/brake pedal all the way down and engage parking brake.

2. Measure distance between brake operating arm and nut "A" on brake rod.
3. If distance is other than 1-1/2", loosen jam nut and turn nut "A" until distance becomes 1-1/2". Retighten jam nut against nut "A".
4. Road test tractor for proper stopping distance as stated above. Readjust if necessary. If stopping distance is still greater than five (5) feet in highest gear, further maintenance is necessary. Replace brake pads or contact a Sears or other qualified service center.

## With Parking Brake "Engaged"

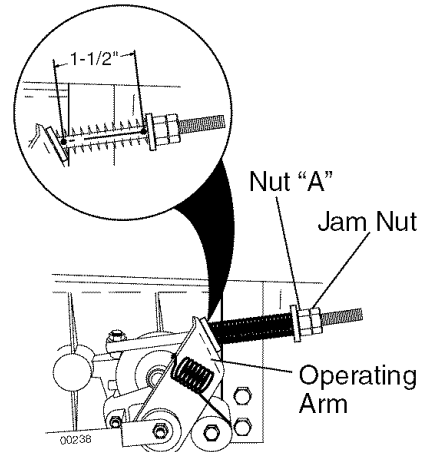

## TO REPLACE MOTION DRIVE BELT

Park the tractor on level surface. Engage parking brake. For assistance, there is a belt installation guide decal on bottom side of left footrest.

## BELT REMOVAL -

1. Remove mower (See "TO REMOVE MOWER" in this section of manual).
- NOTE:** Observe entire motion drive belt and position of all belt guides and keepers.
2. Remove belt from stationary idler and clutching idler.
  3. Remove belt downward from around engine pulley.
  4. Pull belt slack toward rear of tractor. Remove belt upwards from transaxle pulley by deflecting belt keepers.
  5. Remove belt from center span keeper and pull belt away from tractor.

## BELT INSTALLATION -

1. Carefully work new belt down between transaxle belt keepers and onto the input pulley.
2. Slide belt into the center span keeper.
3. Pull belt toward front of tractor and roll around the top groove of engine pulley.
4. Install belt through stationary idler and clutching idler.

5. Make sure belt is in all pulley grooves and inside all belt guides and keepers.
6. Install mower (See "TO INSTALL MOWER" in this section of manual).

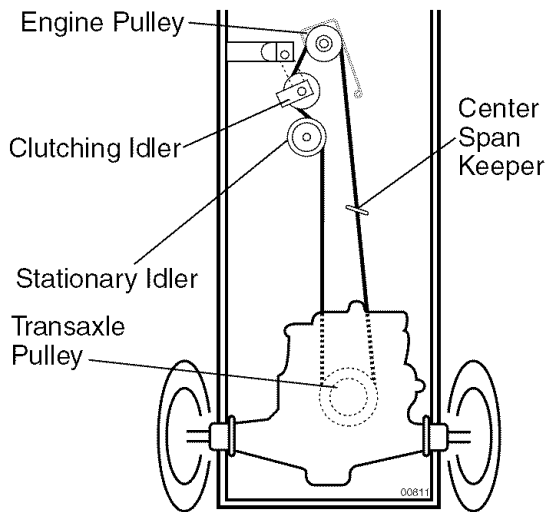

### TRANSAXLE GEAR SHIFT LEVER NEUTRAL ADJUSTMENT

The transaxle should be in neutral when the gear shift lever is in neutral (N) (lock gate) position. The adjustment is preset at the factory; however, if adjustment is needed, proceed as follows:

1. Make sure transaxle is in neutral (N).
- NOTE:** When the tractor rear wheels move freely, the transaxle is in neutral.
2. Loosen adjustment bolt in front of the right rear wheel.
3. Position the gear shift lever in the neutral (N) position.
4. Tighten adjustment bolt securely.

**NOTE:** If additional clearance is needed to get to adjustment bolt, move mower deck height to the lowest position.

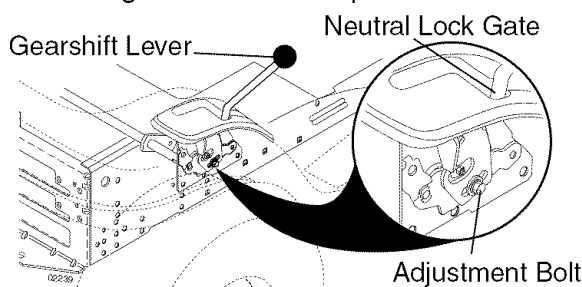

### TO ADJUST STEERING WHEEL ALIGNMENT

If steering wheel crossbars are not horizontal (left to right) when wheels are positioned straight forward, remove steering wheel and reassemble with crossbars horizontal. Tighten securely.

### FRONT WHEEL TOE-IN/CAMBER

The front wheel toe-in and camber are not adjustable on your tractor. If damage has occurred to affect the front wheel toe-in or camber, contact a Sears or other qualified service center.

### TO REMOVE WHEEL FOR REPAIRS

1. Block up axle securely.
2. Remove axle cover, retaining ring and washers to allow wheel removal (rear wheels have a square key - Do not lose).

3. Repair tire and reassemble.

**NOTE:** On rear wheels only: align grooves in rear wheel hub and axle. Insert square key.

4. Replace washers and snap retaining ring securely in axle groove.

5. Replace axle cover.

**NOTE:** To seal tire punctures and prevent flat tires due to slow leaks, purchase and use tire sealant from Sears. Tire sealant also prevents tire dry rot and corrosion.

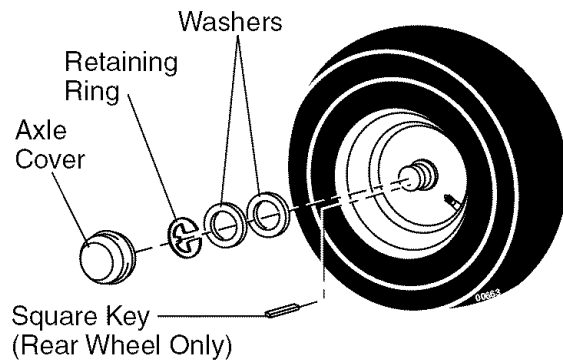

### TO START ENGINE WITH A WEAK BATTERY

**WARNING:** Lead-acid batteries generate explosive gases. Keep sparks, flame and smoking materials away from batteries. Always wear eye protection when around batteries.

If your battery is too weak to start the engine, it should be recharged. (See "BATTERY" in the MAINTENANCE section of this manual).

If "jumper cables" are used for emergency starting, follow this procedure:

**IMPORTANT:** Your tractor is equipped with a 12 volt system. The other vehicle must also be a 12 volt system. Do not use your tractor battery to start other vehicles.

### TO ATTACH JUMPER CABLES -

1. Connect one end of the RED cable to the POSITIVE (+) terminal of each battery(A-B), taking care not to short against tractor chassis.



2. Connect one end of the BLACK cable to the NEGATIVE (-) terminal (C) of fully charged battery.
3. Connect the other end of the BLACK cable (D) to good chassis ground, away from fuel tank and battery.

**TO REMOVE CABLES, REVERSE ORDER -**

1. BLACK cable first from chassis and then from the fully charged battery.
2. RED cable last from both batteries.

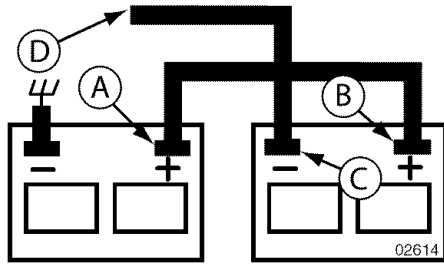

Weak or Dead Battery

Fully Charged Battery

**TO REPLACE HEADLIGHT BULB**

1. Raise hood.
2. Pull bulb holder out of the hole in the backside of the grill.
3. Replace bulb in holder and push bulb holder securely back into the hole in the backside of the grill.
4. Close hood.

**INTERLOCKS AND RELAYS**

Loose or damaged wiring may cause your tractor to run poorly, stop running, or prevent it from starting.

- Check wiring. See electrical wiring diagram in the Repair Parts section.

**TO REPLACE FUSE**

Replace with 20 amp automotive-type plug-in fuse. The fuse holder is located behind the dash.

**TO REMOVE HOOD AND GRILL ASSEMBLY**

1. Raise hood.
2. Unsnap headlight wire connector.
3. Stand in front of tractor. Grasp hood at sides, tilt toward engine and lift off of tractor.
4. When replacing hood, be sure to re-connect the headlight wire connector.

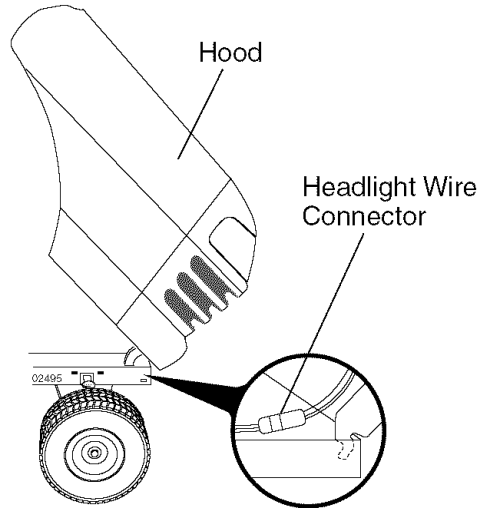

## ENGINE

Maintenance, repair, or replacement of the emission control devices and systems, which are being done at the customer's expense, may be performed by any non-road engine repair establishment or individual. Warranty repairs must be performed by an authorized engine manufacturer's service outlet.

### TO ADJUST THROTTLE CONTROL CABLE

The throttle control has been preset at the factory and adjustment should not be necessary. Check adjustment as described below before loosening cable. If adjustment is necessary, proceed as follows:

1. With engine not running, move throttle control lever from slow to choke position. Slowly move lever from choke to fast position.
2. Check that holes "A" in governor control lever and hole in governor plate line-up. If holes "A" are not aligned, loosen clamp screw and move throttle cable until holes are aligned. Tighten clamp screw securely.

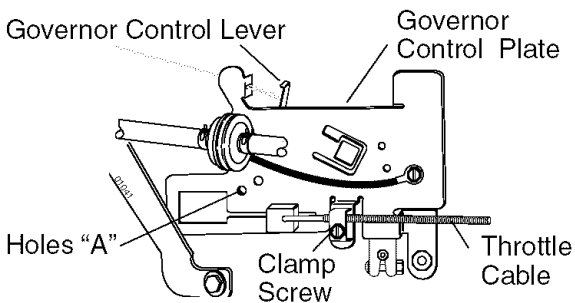

### TO ADJUST CARBURETOR

**NOTE:** The carburetor on this engine is low emission. It is equipped with an idle fuel adjusting needle with a limiter cap, which allows some adjustment within the limits allowed by the cap. Do not attempt to remove the limiter cap. The limiter cap cannot be removed without breaking the adjusting needle.

The carburetor has been preset at the factory and adjustment should not be necessary. However, minor adjustment may be required to compensate for differences in fuel, temperature, altitude or load. If the carburetor does need adjustment, proceed as follows:

In general, turning idle mixture valve **in** (clockwise) decreases the supply of fuel to the engine giving a leaner fuel/air mixture. Turning the idle mixture valve **out** (counterclockwise) increases the supply of fuel to the engine giving a richer fuel/air mixture.

**IMPORTANT:** Damage to the needle valve and the seat in carburetor may result if screw is turned in too tight.

### PRELIMINARY SETTING -

1. Air cleaner assembly must be assembled to the carburetor when making carburetor adjustments.
2. Be sure the throttle control cable is adjusted properly (see above).

### FINAL SETTING -

1. Start engine and allow to warm for five minutes. Make final adjustments with engine running and shift/motion control lever in neutral (**N**) position.
2. Move throttle control lever to slow position. With finger, rotate and hold throttle lever against idle speed screw. Turn idle speed screw to attain 1750 RPM.
3. While still holding throttle lever against idle speed screw, turn idle mixture valve full travel clockwise then counterclockwise until engine runs rough. Turn valve to a point midway between those two positions. Release throttle lever.

### ACCELERATION TEST -

4. Move throttle control lever from slow to fast position. If engine hesitates or dies, turn idle mixture valve **out** (counterclockwise) 1/8 turn. Repeat test and continue to adjust, if necessary, until engine accelerates smoothly.

High speed stop is factory adjusted. Do not adjust - damage may result.

**IMPORTANT:** Never tamper with the engine governor, which is factory set for proper engine speed. Overspeeding the engine above the factory high speed setting can be dangerous. If you think the engine-governed high speed needs adjusting, contact a Sears or other qualified service center, which has proper equipment and experience to make any necessary adjustments.

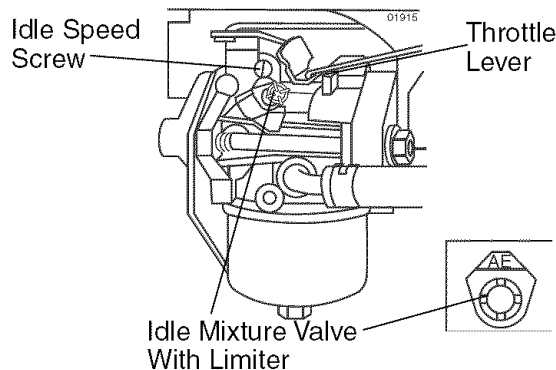

# STORAGE

Immediately prepare your tractor for storage at the end of the season or if the tractor will not be used for 30 days or more.

**⚠️ WARNING:** Never store the tractor with gasoline in the tank inside a building where fumes may reach an open flame or spark. Allow the engine to cool before storing in any enclosure.

## TRACTOR

Remove mower from tractor for winter storage. When mower is to be stored for a period of time, clean it thoroughly, remove all dirt, grease, leaves, etc. Store in a clean, dry area.

1. Clean entire tractor (See “CLEANING” in the Maintenance section of this manual).
2. Inspect and replace belts, if necessary (See belt replacement instructions in the Service and Adjustments section of this manual).
3. Lubricate as shown in the Maintenance section of this manual.
4. Be sure that all nuts, bolts and screws are securely fastened. Inspect moving parts for damage, breakage and wear. Replace if necessary.
5. Touch up all rusted or chipped paint surfaces; sand lightly before painting.

## BATTERY

- Fully charge the battery for storage.
- After a period of time in storage, battery may require recharging.
- To help prevent corrosion and power leakage during long periods of storage, battery cables should be disconnected and battery cleaned thoroughly (see “TO CLEAN BATTERY AND TERMINALS” in the Maintenance section of this manual).
- After cleaning, leave cables disconnected and place cables where they cannot come in contact with battery terminals.
- If battery is removed from tractor for storage, do not store battery directly on concrete or damp surfaces.

## ENGINE

### FUEL SYSTEM

**IMPORTANT:** It is important to prevent gum deposits from forming in essential fuel system parts such as carburetor, fuel hose, or tank during storage. Also, alcohol

blended fuels (called gasohol or using ethanol or methanol) can attract moisture which leads to separation and formation of acids during storage. Acidic gas can damage the fuel system of an engine while in storage.

- Empty the fuel tank by starting the engine and letting it run until the fuel lines and carburetor are empty.
- Never use engine or carburetor cleaner products in the fuel tank or permanent damage may occur.
- Use fresh fuel next season.

**NOTE:** Fuel stabilizer is an acceptable alternative in minimizing the formation of fuel gum deposits during storage. Add stabilizer to gasoline in fuel tank or storage container. Always follow the mix ratio found on stabilizer container. Run engine at least 10 minutes after adding stabilizer to allow the stabilizer to reach the carburetor. Do not empty the gas tank and carburetor if using fuel stabilizer.

### ENGINE OIL

Drain oil (with engine warm) and replace with clean engine oil. (See “ENGINE” in the Maintenance section of this manual).

### CYLINDER(S)

1. Remove spark plug(s).
2. Pour one ounce of oil through spark plug hole(s) into cylinder(s).
3. Turn ignition key to “START” position for a few seconds to distribute oil.
4. Replace with new spark plug(s).

### OTHER

- Do not store gasoline from one season to another.
- Replace your gasoline can if your can starts to rust. Rust and/or dirt in your gasoline will cause problems.
- If possible, store your tractor indoors and cover it to give protection from dust and dirt.
- Cover your tractor with a suitable protective cover that does not retain moisture. Do not use plastic. Plastic cannot breathe which allows condensation to form and will cause your tractor to rust.

**IMPORTANT:** Never cover tractor while engine and exhaust areas are still warm.

## TROUBLESHOOTING CHART:

See appropriate section in manual unless directed to Sears service center

PROBLEM	CAUSE	CORRECTION
<b>Will not start</b>	<ol style="list-style-type: none"> <li>1. Out of fuel.</li> <li>2. Engine not "CHOKED" properly.</li> <li>3. Engine flooded.</li> <li>4. Bad spark plug.</li> <li>5. Dirty air filter.</li> <li>6. Dirty fuel filter.</li> <li>7. Water in fuel.</li> <li>8. Loose or damaged wiring.</li> <li>9. Carburetor out of adjustment.</li> <li>10. Engine valves out of adjustment.</li> </ol>	<ol style="list-style-type: none"> <li>1. Fill fuel tank.</li> <li>2. See "TO START ENGINE" in Operation section.</li> <li>3. Wait several minutes before attempting to start.</li> <li>4. Replace spark plug.</li> <li>5. Clean/replace air filter.</li> <li>6. Replace fuel filter.</li> <li>7. Empty fuel tank and carburetor, refill tank with fresh gasoline and replace fuel filter.</li> <li>8. Check all wiring.</li> <li>9. See "To Adjust Carburetor" in Service and Adjustments section.</li> <li>10. Contact a Sears or other qualified service center.</li> </ol>
<b>Hard to start</b>	<ol style="list-style-type: none"> <li>1. Dirty air filter.</li> <li>2. Bad spark plug.</li> <li>3. Weak or dead battery.</li> <li>4. Dirty fuel filter.</li> <li>5. Stale or dirty fuel.</li> <li>6. Loose or damaged wiring.</li> <li>7. Carburetor out of adjustment.</li> <li>8. Engine valves out of adjustment.</li> </ol>	<ol style="list-style-type: none"> <li>1. Clean/replace air filter.</li> <li>2. Replace spark plug.</li> <li>3. Recharge or replace battery.</li> <li>4. Replace fuel filter.</li> <li>5. Empty fuel tank and refill tank with fresh, clean gasoline.</li> <li>6. Check all wiring.</li> <li>7. See "To Adjust Carburetor" in Service and Adjustments section.</li> <li>8. Contact a Sears or other qualified service center.</li> </ol>
<b>Engine will not turn over</b>	<ol style="list-style-type: none"> <li>1. Clutch/brake pedal not depressed.</li> <li>2. Attachment clutch is engaged.</li> <li>3. Weak or dead battery.</li> <li>4. Blown fuse.</li> <li>5. Corroded battery terminals.</li> <li>6. Loose or damaged wiring.</li> <li>7. Faulty ignition switch.</li> <li>8. Faulty solenoid or starter.</li> <li>9. Faulty operator presence switch(es).</li> </ol>	<ol style="list-style-type: none"> <li>1. Depress clutch/brake pedal.</li> <li>2. Disengage attachment clutch.</li> <li>3. Recharge or replace battery.</li> <li>4. Replace fuse.</li> <li>5. Clean battery terminals.</li> <li>6. Check all wiring.</li> <li>7. Check/replace ignition switch.</li> <li>8. Check/replace solenoid or starter.</li> <li>9. Contact a Sears or other qualified service center.</li> </ol>
<b>Engine clicks but will not start</b>	<ol style="list-style-type: none"> <li>1. Weak or dead battery.</li> <li>2. Corroded battery terminals.</li> <li>3. Loose or damaged wiring.</li> <li>4. Faulty solenoid or starter.</li> </ol>	<ol style="list-style-type: none"> <li>1. Recharge or replace battery.</li> <li>2. Clean battery terminals.</li> <li>3. Check all wiring.</li> <li>4. Check/replace solenoid or starter.</li> </ol>

## TROUBLESHOOTING CHART:

See appropriate section in manual unless directed to Sears service center

PROBLEM	CAUSE	CORRECTION
<b>Loss of power</b>	<ol style="list-style-type: none"> <li>Cutting too much grass/too fast.</li> <li>Throttle in "CHOKE" position.</li> <li>Build-up of grass, leaves and trash under mower.</li> <li>Dirty air filter.</li> <li>Low oil level/dirty oil.</li> <li>Faulty spark plug.</li> <li>Dirty fuel filter.</li> <li>Stale or dirty fuel.</li> <li>Water in fuel.</li> <li>Spark plug wire loose.</li> <li>Dirty engine air screen/fins.</li> <li>Dirty/clogged muffler.</li> <li>Loose or damaged wiring.</li> <li>Carburetor out of adjustment.</li> <li>Engine valves out of adjustment.</li> </ol>	<ol style="list-style-type: none"> <li>Raise cutting height/reduce speed.</li> <li>Adjust throttle control.</li> <li>Clean underside of mower housing.</li> <li>Clean/replace air filter.</li> <li>Check oil level/change oil.</li> <li>Clean and regap or change spark plug.</li> <li>Replace fuel filter.</li> <li>Empty fuel tank and refill tank with fresh, clean gasoline.</li> <li>Empty fuel tank and carburetor, refill tank with fresh gasoline and replace fuel filter.</li> <li>Connect and tighten spark plug wire.</li> <li>Clean engine air screen/fins.</li> <li>Clean/replace muffler.</li> <li>Check all wiring.</li> <li>See "To Adjust Carburetor" in Service and Adjustments section.</li> <li>Contact a Sears or other qualified service center.</li> </ol>
<b>Excessive vibration</b>	<ol style="list-style-type: none"> <li>Worn, bent or loose blade.</li> <li>Bent blade mandrel.</li> <li>Loose/damaged part(s).</li> </ol>	<ol style="list-style-type: none"> <li>Replace blade. Tighten blade bolt.</li> <li>Contact a Sears or other qualified service center.</li> <li>Tighten loose part(s). Replace damaged parts.</li> </ol>
<b>Engine continues to run when operator leaves seat with attachment clutch engaged</b>	<ol style="list-style-type: none"> <li>Faulty operator-safety presence control system.</li> </ol>	<ol style="list-style-type: none"> <li>Check wiring, switches and connections. If not corrected, contact Sears or other qualified service center.</li> </ol>
<b>Poor cut - uneven</b>	<ol style="list-style-type: none"> <li>Worn, bent or loose blade.</li> <li>Mower deck not level.</li> <li>Buildup of grass, leaves, and trash under mower.</li> <li>Bent blade mandrel.</li> <li>Clogged mower deck vent holes from buildup of grass, leaves, and trash around mandrels.</li> </ol>	<ol style="list-style-type: none"> <li>Replace blade. Tighten blade bolt.</li> <li>Level mower deck.</li> <li>Clean underside of mower housing.</li> <li>Contact a Sears or other qualified service center.</li> <li>Clean around mandrels to open vent holes.</li> </ol>

**TROUBLESHOOTING CHART:**

See appropriate section in manual unless directed to Sears service center

<b>PROBLEM</b>	<b>CAUSE</b>	<b>CORRECTION</b>
<b>Mower blades will not rotate</b>	<ol style="list-style-type: none"> <li>1. Obstruction in clutch mechanism.</li> <li>2. Worn/damaged mower drive belt.</li> <li>3. Frozen idler pulley.</li> <li>4. Frozen blade mandrel.</li> </ol>	<ol style="list-style-type: none"> <li>1. Remove obstruction.</li> <li>2. Replace mower drive belt.</li> <li>3. Replace idler pulley.</li> <li>4. Contact a Sears or other qualified service center.</li> </ol>
<b>Poor grass discharge</b>	<ol style="list-style-type: none"> <li>1. Engine speed too slow.</li> <li>2. Travel speed too fast.</li> <li>3. Wet grass.</li> <li>4. Mower deck not level.</li> <li>5. Low/uneven tire air pressure.</li> <li>6. Worn, bent or loose blade.</li> <li>7. Buildup of grass, leaves and trash under mower.</li> <li>8. Mower drive belt worn.</li> <li>9. Blades improperly installed.</li> <li>10. Improper blades used.</li> <li>11. Clogged mower deck vent holes from buildup of grass, leaves, and trash around mandrels.</li> </ol>	<ol style="list-style-type: none"> <li>1. Place throttle control in "FAST" position.</li> <li>2. Shift to slower speed.</li> <li>3. Allow grass to dry before mowing.</li> <li>4. Level mower deck.</li> <li>5. Check tires for proper air pressure.</li> <li>6. Replace/sharpen blade. Tighten blade bolt.</li> <li>7. Clean underside of mower housing.</li> <li>8. Replace mower drive belt.</li> <li>9. Reinstall blades sharp edge down.</li> <li>10. Replace with blades listed in this manual.</li> <li>11. Clean around mandrels to open vent holes.</li> </ol>
<b>Headlight(s) not working (if so equipped)</b>	<ol style="list-style-type: none"> <li>1. Switch is "OFF".</li> <li>2. Bulb(s) or lamp(s) burned out.</li> <li>3. Faulty light switch.</li> <li>4. Loose or damaged wiring.</li> <li>5. Blown fuse.</li> </ol>	<ol style="list-style-type: none"> <li>1. Turn switch "ON".</li> <li>2. Replace bulb(s) or lamp(s).</li> <li>3. Check/replace light switch.</li> <li>4. Check wiring and connections.</li> <li>5. Replace fuse.</li> </ol>
<b>Battery will not charge</b>	<ol style="list-style-type: none"> <li>1. Bad battery cell(s).</li> <li>2. Poor cable connections.</li> <li>3. Faulty regulator (if so equipped).</li> <li>4. Faulty alternator.</li> </ol>	<ol style="list-style-type: none"> <li>1. Replace battery.</li> <li>2. Check/clean all connections.</li> <li>3. Replace regulator.</li> <li>4. Replace alternator.</li> </ol>
<b>Engine "backfires" when turning engine "OFF"</b>	<ol style="list-style-type: none"> <li>1. Engine throttle control not set between half and full speed (fast) position before stopping engine.</li> </ol>	<ol style="list-style-type: none"> <li>1. Move throttle control between half and full speed (fast) position before stopping engine.</li> </ol>

# TRACTOR -- MODEL NUMBER 917.277252

## SCHEMATIC

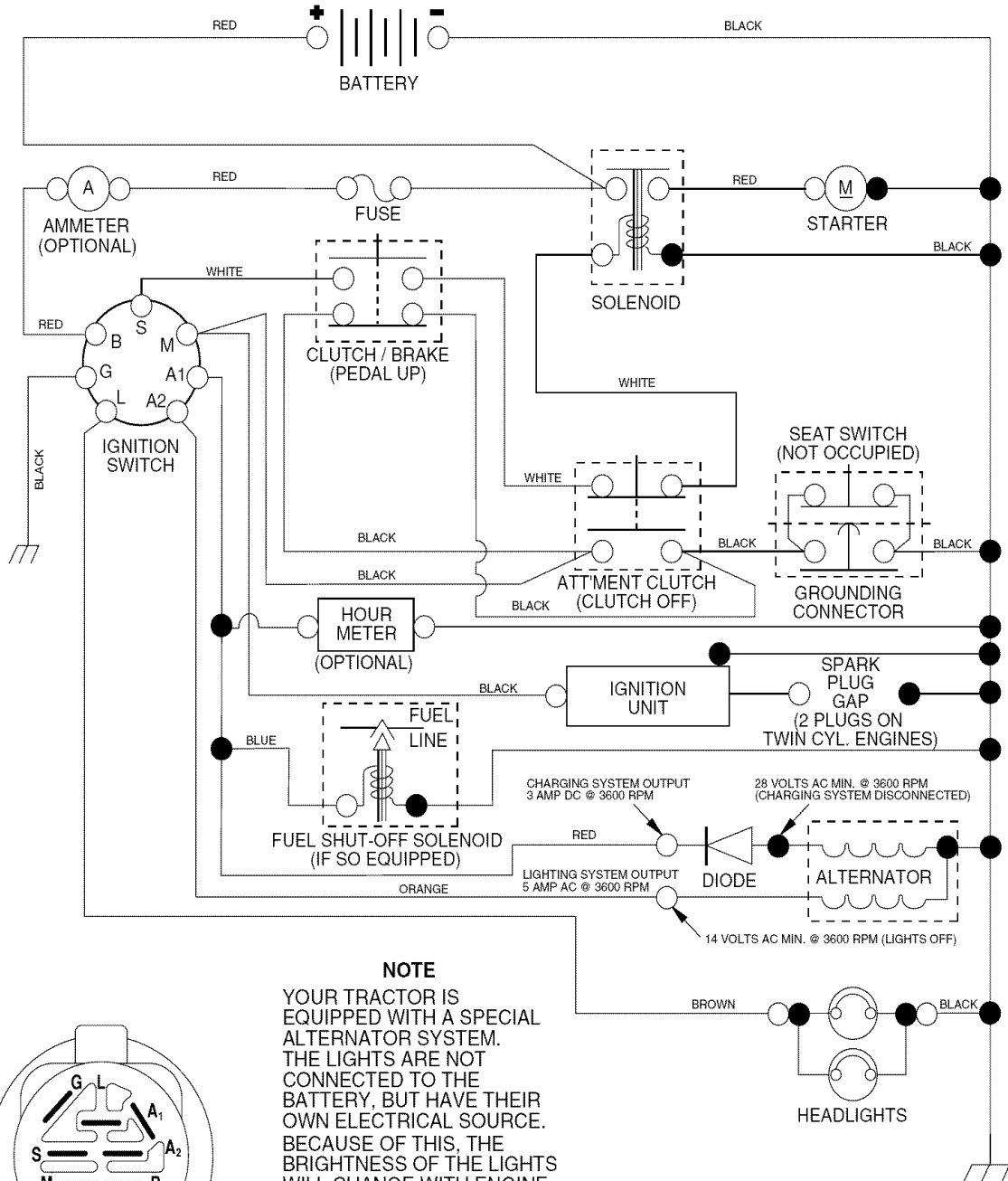

### NOTE

YOUR TRACTOR IS EQUIPPED WITH A SPECIAL ALTERNATOR SYSTEM. THE LIGHTS ARE NOT CONNECTED TO THE BATTERY, BUT HAVE THEIR OWN ELECTRICAL SOURCE. BECAUSE OF THIS, THE BRIGHTNESS OF THE LIGHTS WILL CHANGE WITH ENGINE SPEED. AT IDLE THE LIGHTS WILL DIM. AS THE ENGINE IS SPEEDED UP, THE LIGHTS WILL BECOME THEIR BRIGHTEST.

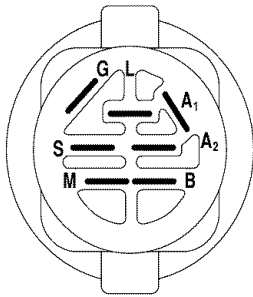

**IGNITION SWITCH**

POSITION	CIRCUIT	"MAKE"
OFF	M+G+A1	NONE
RUN/LIGHT	B+A1	A2+L
RUN	B+A1	NONE
START	B + S + A1	NONE

### WIRING INSULATED CLIPS

**NOTE:** IF WIRING INSULATED CLIPS WERE REMOVED FOR SERVICING OF UNIT, THEY SHOULD BE REPLACED TO PROPERLY SECURE YOUR WIRING.

02363

NON-REMOVABLE CONNECTIONS

REMOVABLE CONNECTIONS





# ELECTRICAL

## TRACTOR - - MODEL NUMBER 917.277252

KEY NO.	PART NO.	DESCRIPTION
1	163465	Battery
2	74760412	Bolt Hex Hd 1/4-20 unc x 3/4
8	176689	Box Battery Fender
16	176138	Switch, Interlock
21	183759	Harness Asm Light W/4152j
22	4152J	Bulb Light #1156
24	4799J	Cable Battery 6 Ga. 11" red
25	146147	Cable Battery 6 Ga. w/16 wire red
26	175158	Fuse 20 AMP
27	73510400	Nut, Keps Hex 1/4-20 unc
28	4207J	Cable Ground 6 Ga. 12" black
29	121305X	Switch Plunger Nc Gray
30	175566	Switch Ign
33	140403	Key Ign Molded Craftsman
40	179720	Harness Ign
41	71110408	Bolt Blk. Fin Hex 1/4-20 unc x 1/2
42	131563	Cover Terminal Red
43	192507	Solenoid
48	140844	Ammeter Adapter
52	141940	Protection Wire Loop
90	180449	Cover Battery Terminal

**NOTE:** All component dimensions give in U.S. inches  
1 inch = 25.4 mm

# TRACTOR - - MODEL NUMBER 917.277252

## CHASSIS AND ENCLOSURES

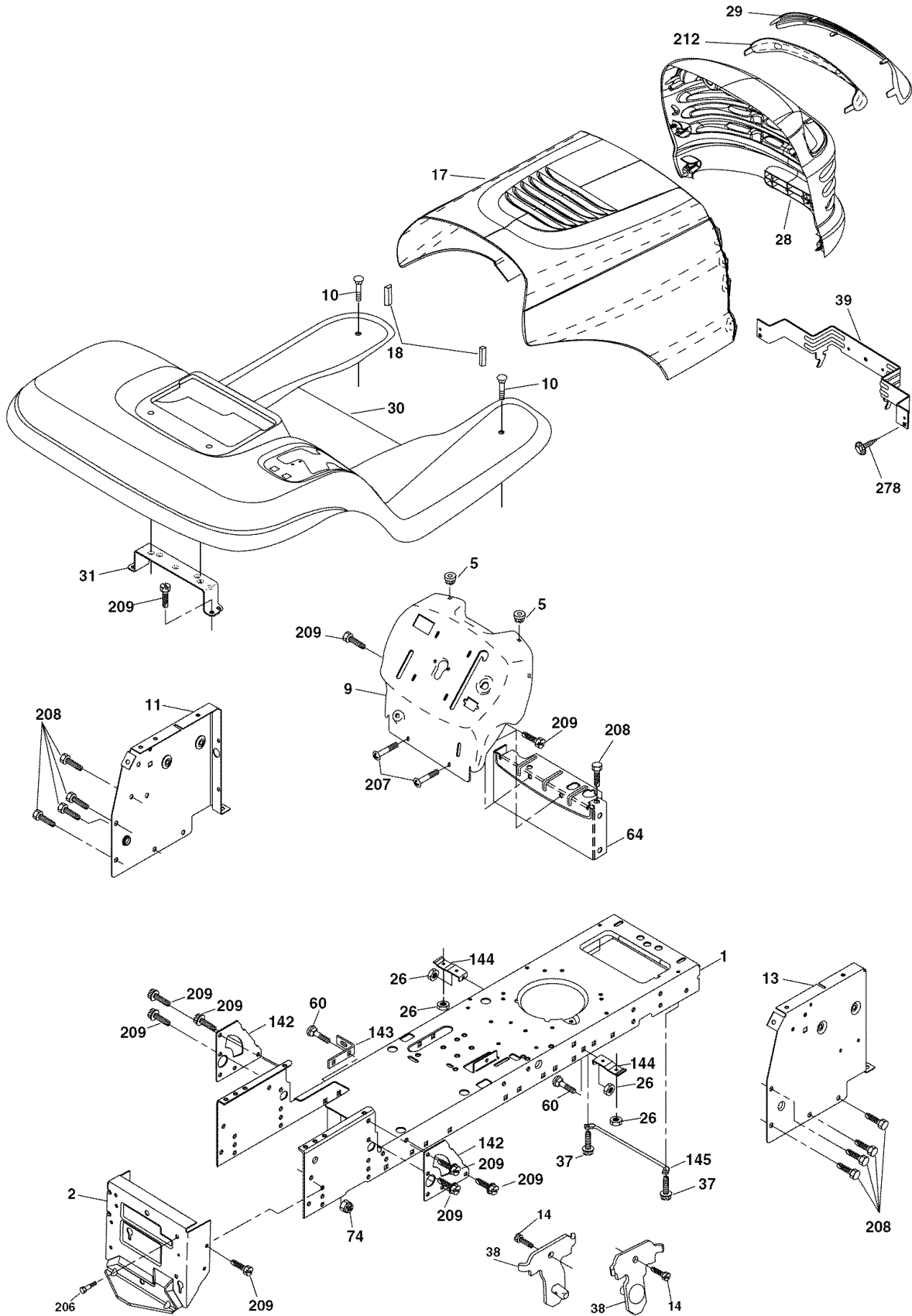

chassis-Laser -lt.stlt\_27

**TRACTOR - - MODEL NUMBER 917.277252**  
**CHASSIS AND ENCLOSURES**

<b>KEY NO.</b>	<b>PART NO.</b>	<b>DESCRIPTION</b>
1	174619	Chassis Stamping
2	176554	Drawbar
5	155272	Bumper Hood/Dash
9	193510X012	Dash
10	STD533710	Bolt, Carriage 3/8-16 x 1
11	174996	Panel, Dash, L.H.
13	172105X010	Panel, Dash, R.H.
14	17490608	Screw Thdrol 3/8-16 x 1/2
17	185682X558	Hood Assembly Laser
18	184921	Bumper Extrusion
26	STD541437	Nut
28	188636	Grille Lens Asm Laser (Includes Key Nos. 29 and 212)
29	174332X599	Lens, Laser
30	192394X558	Fend/Ftrest Pnt STL
31	139976	Bracket, Fender Support
37	17490508	Screw Thdrol 5/16-18 x 1/2 Tyt
38	175710	Bracket Asm. Pivot Mower Rear
39	174714	Bracket Pivot Laser
60	72140606	Bolt Rdhd Sqnk 3/8-16 unc x 3/4
64	154798	Dash Lower STL
74	73680600	Nut Crownlock 3/8-16 unc
142	175702	Plate Reinforcement STL
143	186689	Bracket Swaybar Chassis
144	175582	Bracket Pnt Footrest STL
145	156524	Rod Pivot Chassis/Hood
206	170165	Bolt Shoulder 5/16 -18 TT
207	17670508	Screw Thdrol 5/16-18 x 1/2 TYTT
208	17670608	Screw Thdrol 3/8-16 x 1/2
209	17000612	Screw Thdrol 3/8-16 x 3/4
212	175143	Insert Lens Reflective
278	191611	Screw 10 x 3/4 Single Lead-Hex
--	5479J	Plug, Button
--	187801	Plug, Domed Plastic
--	193640X428	Plug Light Switch

**NOTE:** All component dimensions give in U.S. inches  
1 inch = 25.4 mm

# TRACTOR -- MODEL NUMBER 917.277252

## GROUND DRIVE

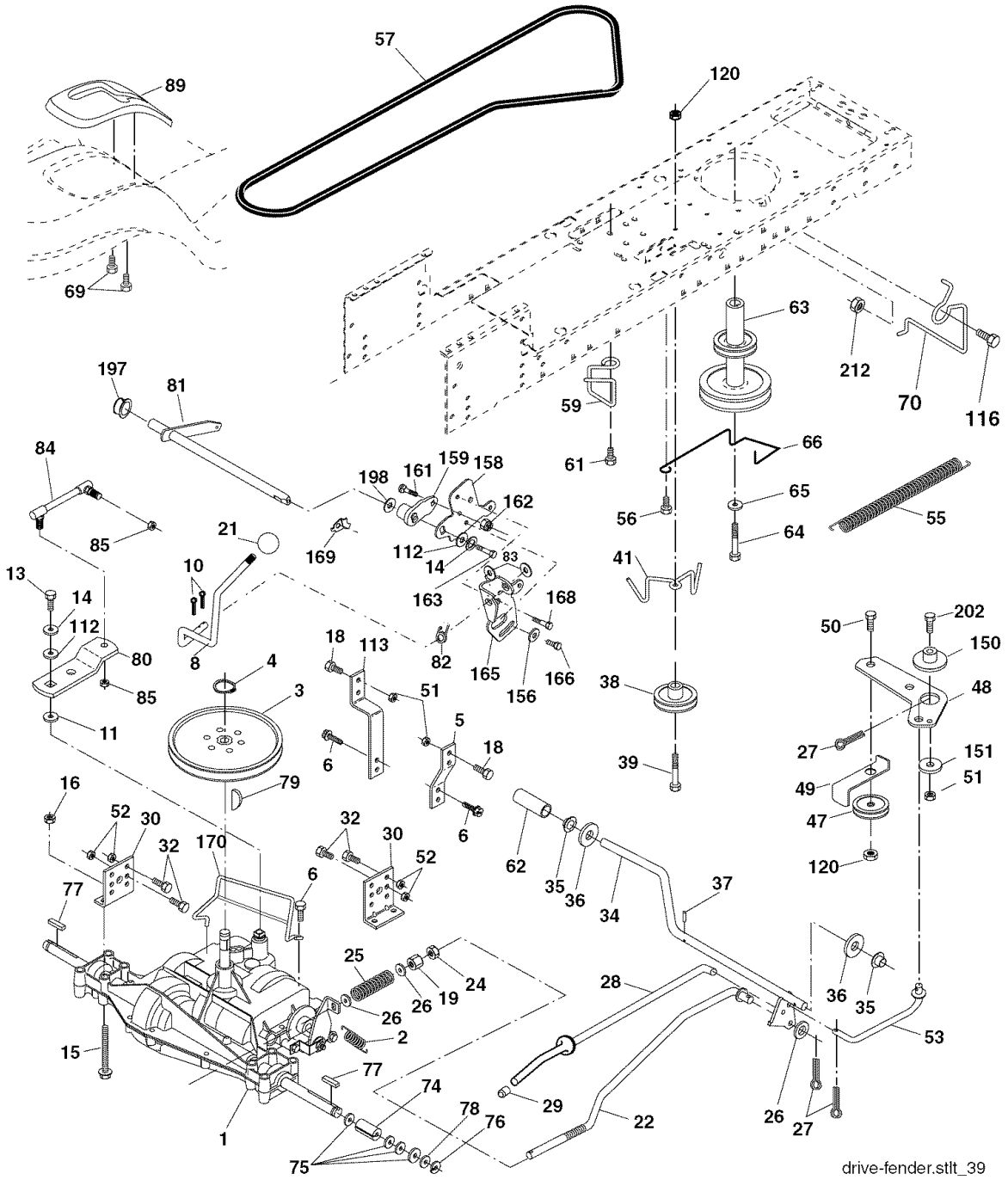

drive-fender.stlt\_39

## TRACTOR - - MODEL NUMBER 917.277252

### GROUND DRIVE

KEY NO.	PART NO.	DESCRIPTION	KEY NO.	PART NO.	DESCRIPTION
1	-----	Transaxle Peerless 205-544C (See Breakdown)	62	8883R	Cover, Pedal
2	146682	Spring Brake Return	63	175410	Pulley, Engine
3	123666X	Pulley Transaxle	64	173937	Bolt Hex 7/16-20 x 4 x Gr. 5
4	12000028	Ring Retainer	65	STD551143	Washer
5	121520X	Strap Torque 30 Degrees	66	154778	Keeper Belt Engine Hydro
6	17060512	Screw 5/16-18 x 3/4	69	142432	Screw Hex Wsh Hi-Lo 1/4-1/2 unc
8	192502	Rod Shift Fender Adjust	70	134683	Keeper Belt Engine
10	STD561210	Pin Cotter 1/8 x 1 CAD	74	137057	Spacer
11	105701X	Washer Plate Shift	75	121749X	Washer 25/32 x 1-1/4 x 16 Ga.
13	74550412	Bolt 1/4-28unf Gr. 8 W/Patch	76	STD581075	E-Ring
14	10040400	Washer Lock Hvy Helical	77	123583X	Key, Square
15	74490544	Bolt Hex FLGHD 5/16-18 x Gr. 5	78	121748X	Washer 25/32 x 1-5/8 x 16 Ga.
16	STD541431	Nut Lock Hex W/Ins. 5/16-18 unc	79	2228M	Key Woodruff
18	74780616	Bolt Fin Hex 3/8-16 x 1 Gr. 5	80	131486	Arm Shift
19	STD541437	Nut Lock Hex W/Wsh 3/8-16 unc	81	165594	Shaft Asm Cross Tapered
21	106933X	Knob	82	165711	Spring Torsion
22	130804	Rod, Brake	83	19171216	Washer 17/32 x 3/4 x 16 Ga.
24	73350600	Nut, Hex Jam 3/8-16 unc	84	166228	Link Transaxle
25	106888X	Spring, Brake Rod	85	150360	Nut Lock Center 1/4-20
26	STD551037	Washer 13/32 x 13/16 Ga.	89	192389X428	Console, Shift
27	STD561210	Pin Cotter 1/8 x 3/4 CAD.	96	4497H	Retainer Spring 1" Zinc/Cad
28	175765	Rod, Parking Brake	99	17000512	Screw 5/16-18 x 3/4
29	71673	Cap, Parking Brake	112	19091210	Washer 9/32 x 3/4 x 10 Ga.
30	174973	Bracket, Transaxle	113	127285X	Strap Torque 90 Degrees
32	74760512	Bolt Hex Hd 5/16-18 unc x 3/4	116	72140608	Bolt Rdhd Sqneck 3/8-16 x 1.25
34	175578	Shaft, Foot Pedal	120	73900600	Nut Lock Flg 3/8-16
35	120183X	Bearing, Nylon	150	175456	Spacer Retainer
36	19211616	Washer	151	19133210	Washer 13/32 x 2 x 10 Ga.
37	1572H	Pin, Roll	156	166002	Washer Srrted 5/16 ID x 1.125
38	179114	Pulley, Composite, Flat	158	165589	Bracket Shift Mount
39	72110622	Bolt Rdhd 3/8-16 unc x 2-3/4 Gr. 5	159	183900	Hub Shift
41	175556	Keeper, Belt Idler	161	72140406	Bolt Rdhd Sqnk 1/4-20 x 3/4 Gr. 5
47	127783	Pulley, Idler, V-Groove	162	73680400	Nut Crownlock 1/4-20 unc
48	154407	Bellcrank, Clutch	163	74780416	Bolt Hex Fin 1/4-20 unc x 1 Gr. 5
49	123205X	Retainer, Belt	165	165623	Bracket Pivot Lever
50	72110612	Bolt Carr 3/8-16 x 1-1/2	166	17490510	Screw 5/16-18 x 5/8
51	STD541437	Nut Crownlock 3/8-16 unc	168	165492	Bolt Shoulder 5/16-18 x .561
52	STD541431	Nut, Crownlock 5/16-18 unc	169	165580	Plate Fastening
53	105710X	Link, Clutch	170	187414	Keeper Belt T/A
55	105709X	Spring, Return, Clutch	197	169613	Nyliner Snap-In 5/8"ID
56	17060620	Screw 3/8-16 x 1-1/4	198	169593	Washer Nyl 7/8 ID x .105" Hyd
57	130801	V-Belt	202	72110614	Bolt Carr Sh 3/8-16 x 1-3/4 Gr. 5
59	169691	Keeper, Center Span	212	145212	Nut Hex Flg. Lock
61	17120614	Screw . 3/8-16 x .875			

NOTE: All component dimensions given in U.S. inches  
1 inch = 25.4 mm

# TRACTOR - - MODEL NUMBER 917.277252

## STEERING ASSEMBLY

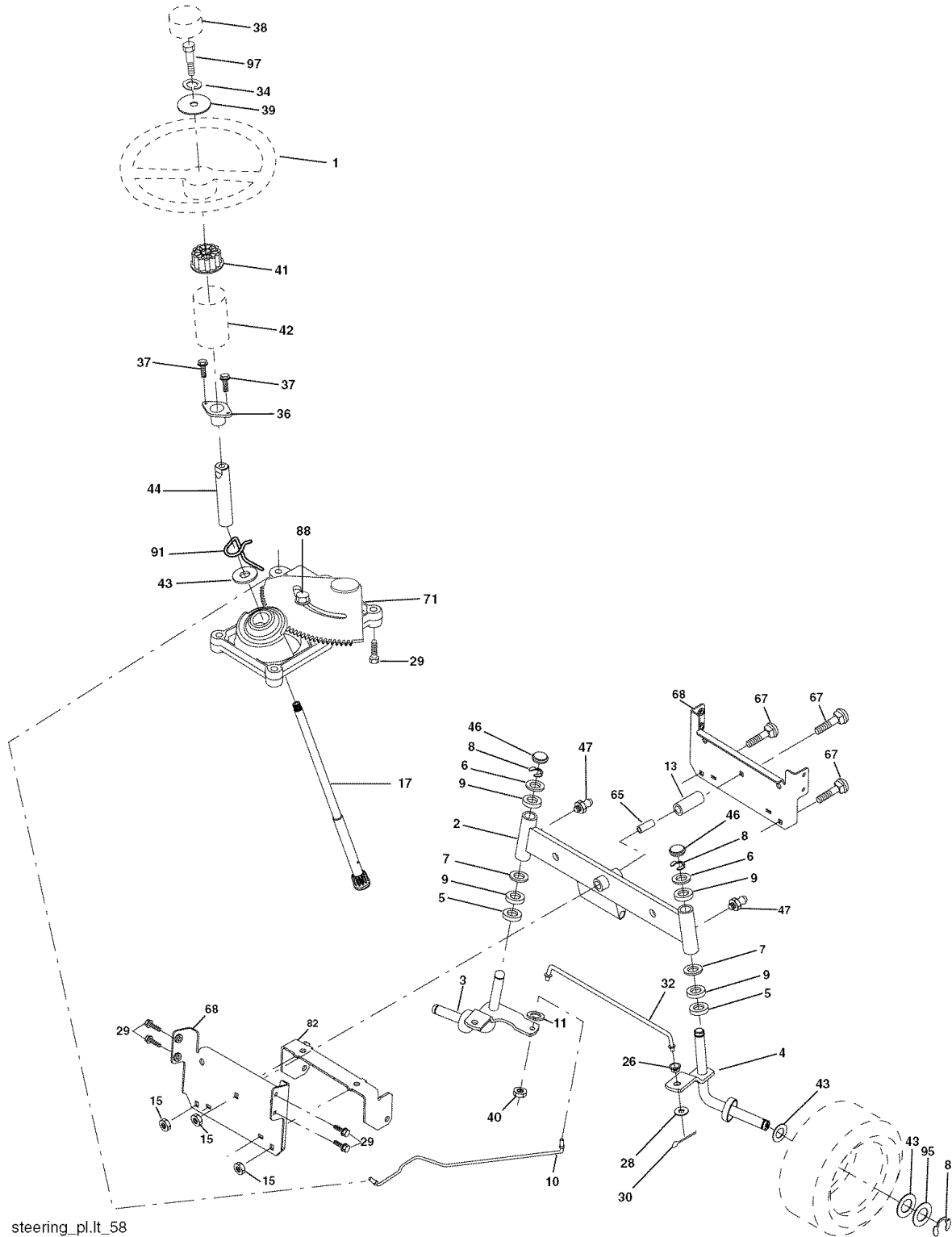

steering\_pl.lt\_58

**TRACTOR - - MODEL NUMBER 917.277252**  
**STEERING ASSEMBLY**

KEY PART NO.	NO.	DESCRIPTION
1	186780	Steering Wheel
2	175131	Axle Assembly STMP Dropped STL
3	169840	Spindle Assembly, L.H.
4	169839	Spindle Assembly, R.H.
5	6266H	Bearing, Race, Thrust, Hardened
6	121748X	Washer 25/32 x 1-5/8 x 16 Ga.
7	19272016	Washer 27/32 x 1-1/4 x 16 Ga.
8	12000029	Ring, Klip
9	3366R	Bearing, Steering Column
10	175121	Draglink
11	10040600	Washer, Lock
13	136518	Spacer Brg Axle Front
15	145212	Nut, Hexflange Lock
17	190753	Shaft Assembly, Steering
26	126847X	Bushing, Link, Drag
28	19131416	Washer 13/32 x 7/8 x 16 Ga.
29	17000612	Screw 3/8-16 x 3/4
30	STD561210	Pin
32	192757	Rod, Tie
34	10040500	Washer Lock Hvy Hlcl Spr 5/16
36	155099	Bushing, Steering
37	152927	Screw
38	186781	Insert, Steering Wheel
39	19113812	Washer 11/32 ID x 2-3/8 OD x 12 Ga.
40	73540600	Nut Crownlock 3/8-24
41	186737	Adaptor, Steering Wheel
42	145054x428	Boot, Steering Shaft
43	121749X	Washer 25/32 x 1-1/4 x 16 Ga.
44	190752	Extension Shaft Steering
46	121232X	Cap, Spindle
47	183226	Fitting, Grease
65	160367	Spacer Brace Axle
67	72110618	Bolt Rdhd Sqnk 3/8-16 x 2-1/4
68	169827	Axle, Brace
71	175146	Steering Asm
82	169835	Bracket Susp Chassis Front
88	175118	Bolt Shoulder 7/16-20
91	175553	Clip Steering
95	188967	Washer Harden .793 x 1.637 x .060
97	74780564	Bolt 5/16-18 unc x 4"L Gr. 5

**NOTE:** All component dimensions given in U.S. inches  
1 inch = 25.4 mm

# TRACTOR - - MODEL NUMBER 917.277252

## ENGINE

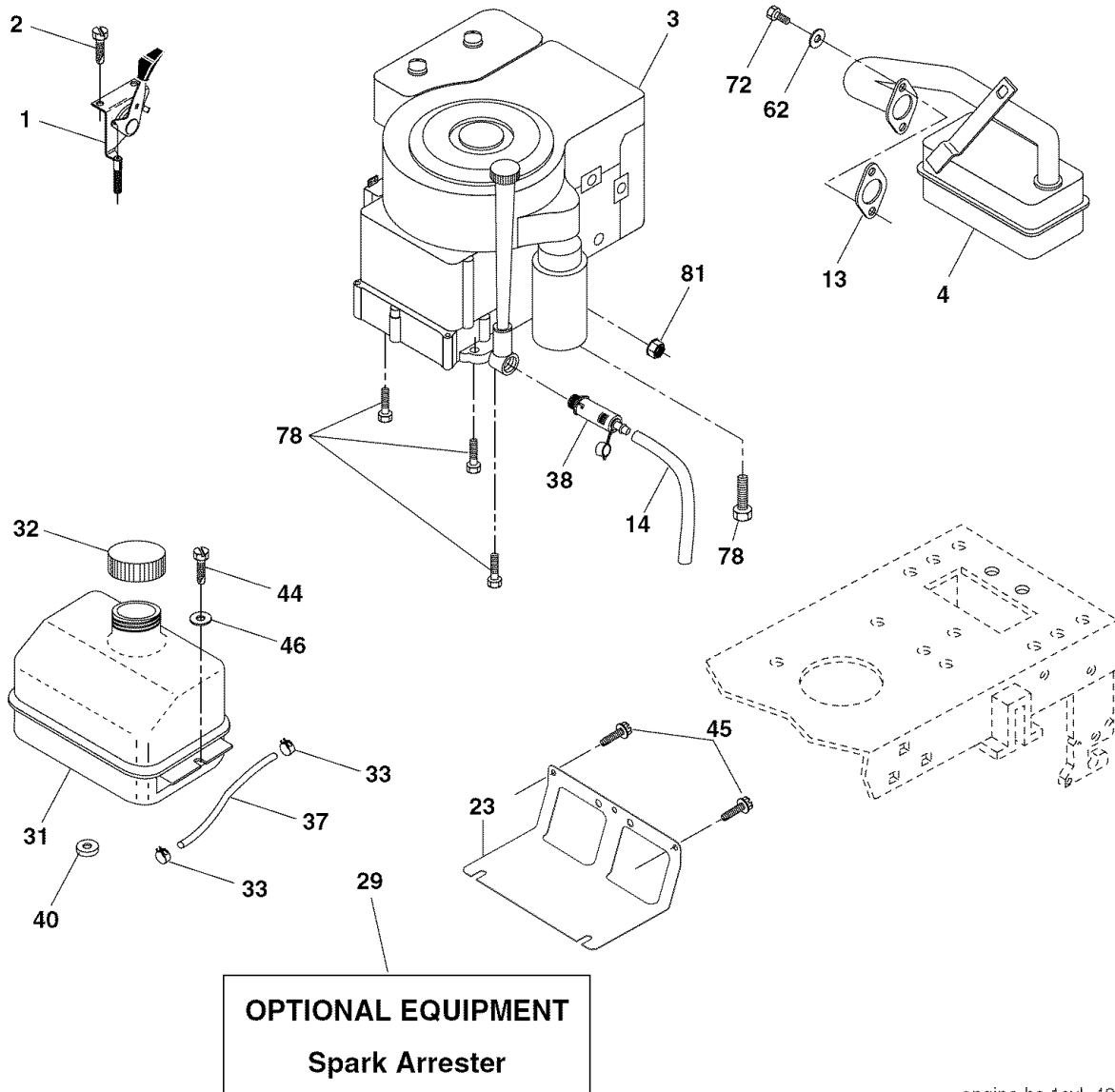

engine-bs.1cyl\_49

KEY PART NO.	PART NO.	DESCRIPTION
1	170551	Control, Throttle/Choke
2	17720408	Screw, Hex Head, Thread Cutting 1/4-20 x 5/8
3	-----	Engine, Briggs Model No. 282H07-0231-E1 (See Breakdown)
4	137352	Muffler
13	165291	Gasket
14	148456	Tube Drain Oil Easy
23	169837	Shield Brn/Dbr Guard
29	137180	Arrestor, Spark
31	187750	Tank, Fuel
32	140527	Cap Assembly Fuel
33	123487X	Clamp, Hose
37	137040	Line, Fuel

### OPTIONAL EQUIPMENT

#### Spark Arrester

KEY PART NO.	PART NO.	DESCRIPTION
38	181654	Plug, Drain Oil Easy
40	124028X	Bushing Snap
44	17670412	Screw, Hex Washer Head, Thd., Roll. 1/4-20 x 3/4
45	17000612	Screw Hex Wsh Thdr 3/8-16 x 3/4
46	19091416	Washer 9/32 x 7/8 x 16 Ga.
62	10010500	Washer Split
72	71070512	Screw Hex Cap 5/16-18 x 3/4
78	17060620	Screw 3/8-16 x 1-1/4
81	73510400	Nut Keps Hex 1/4-20 unc

**NOTE:** All component dimensions given in U.S. inches  
1 inch = 25.4 mm



**TRACTOR - - MODEL NUMBER 917.277252**  
**SEAT ASSEMBLY**

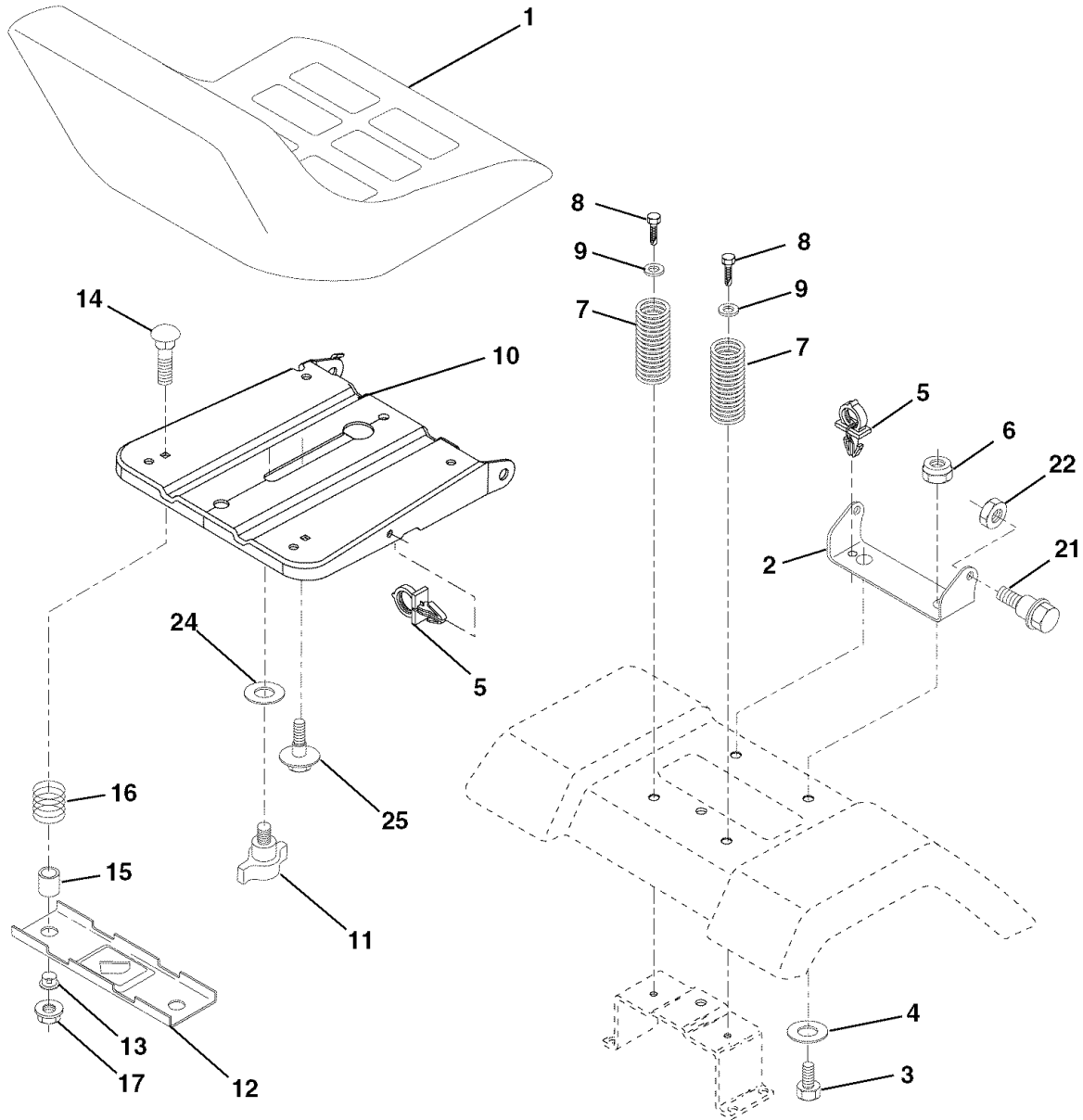

seat\_lt.knob\_13

KEY PART NO.	NO.	DESCRIPTION
1	175389	Seat
2	140551	Bracket, Pivot, Seat
3	71110616	Bolt
4	19131610	Washer 13/32 x 1 x 10 Ga.
5	145006	Clip, Push-In Hinged
6	STD541437	Nut
7	124181X	Spring, Seat
8	17000616	Screw 3/8-16 x 1-1/2
9	19131614	Washer 13/32 x 1 x 14 Ga.
10	182493	Pan, Seat
11	166369	Knob Seat
12	121246X	Bracket, Switch Mounting

KEY PART NO.	NO.	DESCRIPTION
13	121248X	Bushing, Snap
14	72050412	Bolt, Carriage 1/4-20 x 1-1/2
15	134300	Spacer, Split .28 x .88
16	121250X	Spring
17	123976X	Locknut, Flange 1/4 Gr. 5
21	171852	Bolt, Shoulder 5/16-18 unc
22	STD541431	Nut
24	19171912	Washer 17/32 x 1-3/16 x 12 Ga.
25	127018X	Bolt Shoulder 5/16-18 x .62

**NOTE:** All component dimensions given in U.S. inches  
 1 inch = 25.4 mm

# TRACTOR - - MODEL NUMBER 917.277252

## DECALS

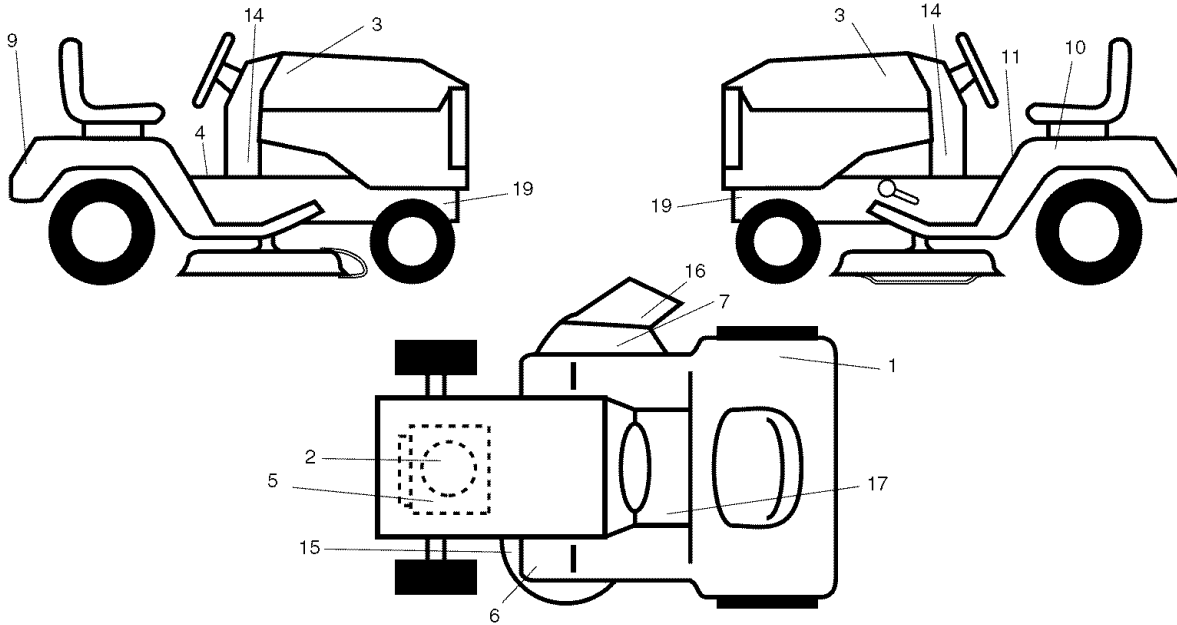

### KEY PART NO. NO.

KEY PART NO.	NO.	DESCRIPTION
1	168869	Decal, Tick Mark
2	198045	Decal, HP Engine
3	171704	Decal, Hood
4	140837	Decal, Brake Parking
5	196841	Decal, Engine Wrng. Symbols
6	197490	Decal, V-Belt Drive Sch
7	196357	Decal, Dflctr Warning Ctfnger Sym
9	163204	Decal, Fender
10	145005	Decal, Battery, Dngr/Psn Eng

### KEY PART NO. NO.

KEY PART NO.	NO.	DESCRIPTION
11	145498	Decal, Read Owner's Manual
14	181685	Decal, Panel Dash
15	136832	Decal, V-Belt Sch
16	182166	Decal, Cutfinger
17	159737	Decal, Brake/Clutch Symbol
19	159736	Decal, Chassis Hot Muffler
--	162598	Decal Drawbar Load Limit
--	138311	Decal, Lift Handle
--	184310X428	Pad Footrest LH STLT
--	184311X428	Pad Footrest RH STLT
--	198133	Manual Owner's English

## WHEELS & TIRES

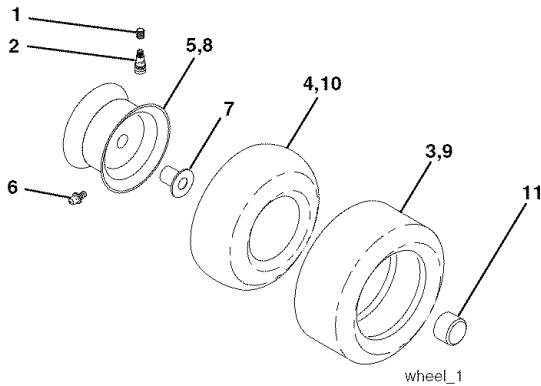

### KEY PART NO. NO.

KEY PART NO.	NO.	DESCRIPTION
1	59192	Valve Cap, Tire
2	65139	Stem, Valve
3	106222X	Tire, Front
4	59904	Tube, Front Tire (Not Provided, Service Item Only)
5	106732X624	Rim, Front
6	278H	Fitting, Grease (Front Wheel Only)
7	9040H	Bearing, Flange (Front Wheel Only)
8	106108X624	Rim, Rear
9	124635X	Tire, Rear
10	7152J	Tube, Rear Tire (Not Provided, Service Item Only)
11	104757X428	Cap, Axle
--	144334	Sealant, Tire 10 oz.

**NOTE:** All component dimensions given in U.S. inches  
1 inch = 25.4 mm

# TRACTOR - - MODEL NUMBER 917.277252

## LIFT ASSEMBLY

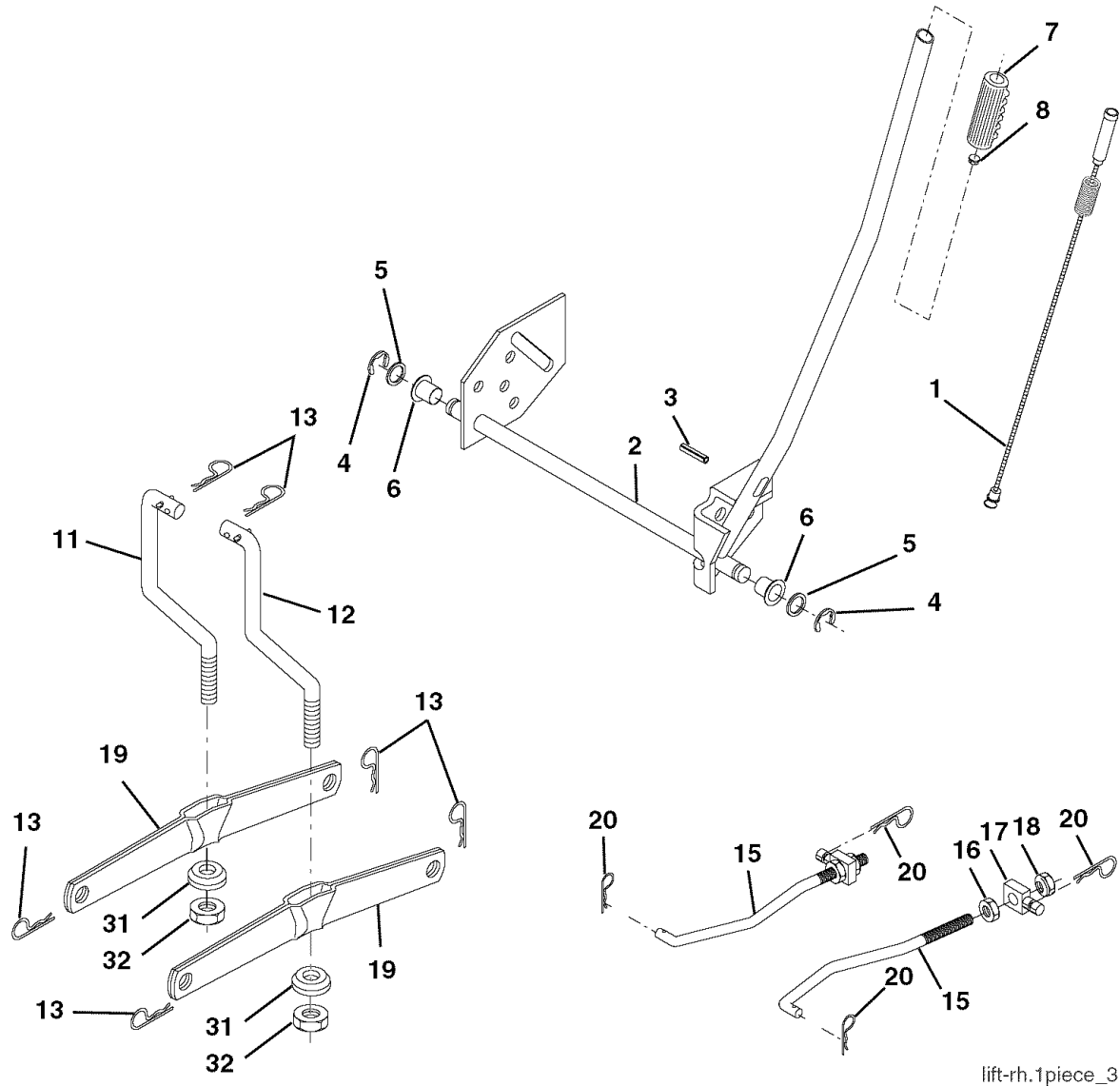

lift-rh.1piece\_3

KEY PART NO.	PART NO.	DESCRIPTION
1	159460	Lift Lever Inner Wire Assembly
2	159471	Shaft Assembly, Lift
3	105767X	Pin, Groove
4	12000002	E-Ring
5	19211621	Washer 21/32 x 1 x 21 Ga.
6	120183X	Bearing, Nylon
7	125631X	Grip, Handle, Fluted
8	122365X	Button, Plunger, Red
11	139865	Link, Lift, L.H.
12	139866	Link, Lift, R.H.
13	STD624008	Retainer Spring

KEY PART NO.	PART NO.	DESCRIPTION
15	173288	Link, Front
16	73350800	Nut, Hex, Jam 1/2-13 unc
17	175689	Trunnion
18	73800800	Locknut, Hex, with Washer Insert 1/2-13 unc
19	139868	Arm, Suspension, Rear
20	163552	Retainer Spring
31	169865	Bearing, Pvt, Lift
32	73540600	Nut, Crownlock 3/8-24

**NOTE:** All component dimensions given in U.S. inches  
1 inch = 25.4 mm

# TRACTOR - - MODEL NUMBER 917.277252

## MOWER DECK

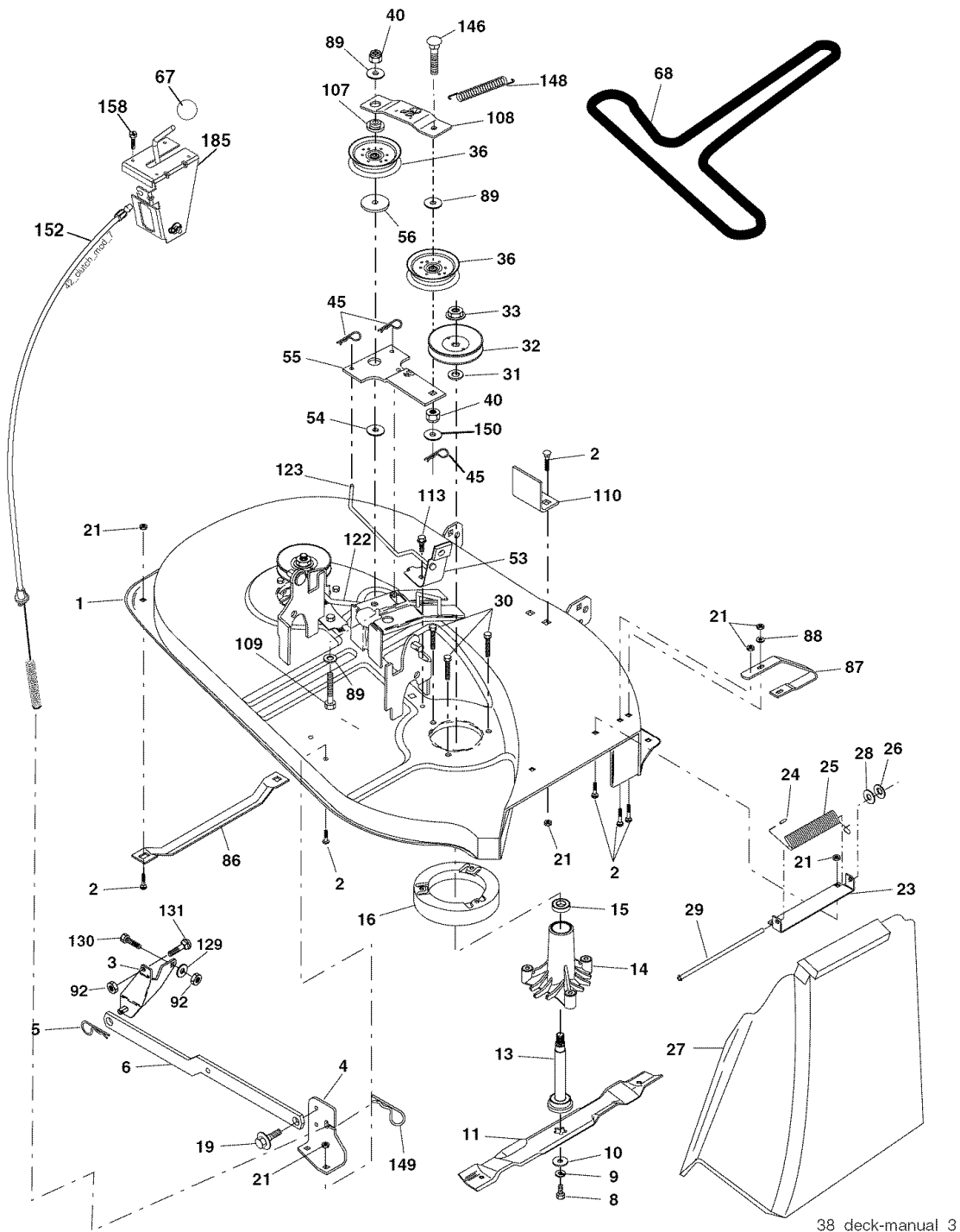

# TRACTOR - - MODEL NUMBER 917.277252

## MOWER DECK

KEY PART NO. NO.	DESCRIPTION	KEY PART NO. NO.	DESCRIPTION
1	170280	56	165723
2	72140506	67	149846
3	138017	68	144200
4	169970	86	7631J
5	4939M	87	128772
6	178024	88	19111216
8	850857	89	19131311
9	10030600	92	73800600
10	140296	107	133502
		108	133503
11	134148	109	74760640
13	137645	110	142587
		113	17060512
14	128774	122	131289
15	110485X	123	169971
16	174493	129	19131312
19	132827	130	74780616
21	73680500	131	72140608
23	137607	146	165891
24	105304X	148	169022
25	123713X	149	165898
26	110452X	150	19091210
27	106736X428	152	172758
28	19111016	158	17720408
29	106735X	185	188234
30	173984	--	130794
31	187690		
32	153532		
33	178342		
36	131494	--	171591
40	73680600		
45	4497H		
53	130840		
54	178515		
55	133840		

**NOTE:** All component dimensions given in U.S. inches  
1 inch = 25.4 mm

**TRACTOR - - MODEL NUMBER 917.277252**  
**PEERLESS TRANSAXLE - - MODEL NUMBER 205-544C**

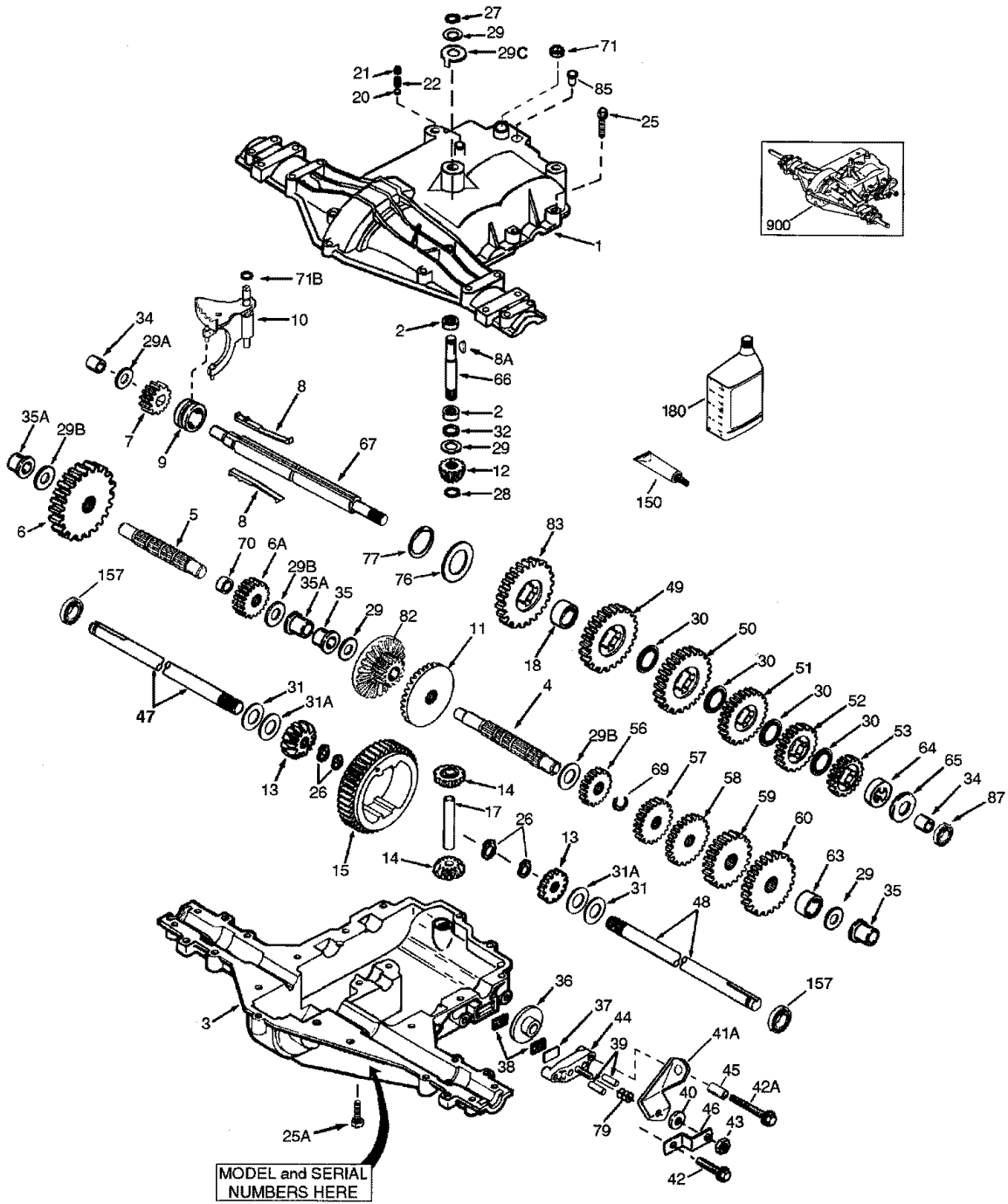

**TRACTOR - - MODEL NUMBER 917.277252**  
**PEERLESS TRANSAXLE - - MODEL NUMBER 205-544C**

KEY NO.	PART NO.	DESCRIPTION	KEY NO.	PART NO.	DESCRIPTION
1	772147	Transaxle Cover	39	786026	Dowel Pin
2	780086A	Needle Bearing 5 / 8"	40	792076A	Flat Washer .312 ID x .059W
3	770128	Transaxle Case	41A	790079	Brake Lever
4	776395	Countershaft	42	792073A	Screw 1 / 4 - 20 x 1 - 1 / 4"
5	776409	Output Shaft	42A	792085A	Screw 1 / 4 - 20 x 2 - 1 / 4"
6	778364	Spur Gear (38 teeth)	43	792075	Locknut 5 / 16 - 24
6A	778369	Spur Gear (15 teeth)	44	790025	Brake Pad Holder
7	778330	Spur Gear (11 teeth)	45	786066	Spacer .2625 x 1.0
8	792180	Shift Key	46	786086	Brake Lever Bracket
8A	792047	Woodruff Key #9	47	774690	Axle (11 - 15 / 16 " long)
9	784352	Shift Collar	48	774691	Axle (16 - 1 / 2" long)
10	784378	Shift Rod & Fork	49	778356	Spur Gear (29 teeth)
11	778334	Bevel Gear (30 teeth)	50	778354	Spur Gear (23 teeth)
12	778309	Input Bevel Pinion (13 teeth)	51	778352	Spur Gear (19 teeth)
13	778368	Bevel Gear (13 teeth) (Include. 14)	52	778350	Spur Gear (16 teeth)
14	778368	Bevel Pinion (13 teeth) (Include 13)	53	778346	Spur Gear (15 teeth)
15	778370	Ring Gear (43 teeth)	53	778346	Spur Gear (15 teeth - steel)
17	786188	Drive Pin	56	778355	Spur Gear (11 teeth)
18	786102	Spacer 1.130 x .695	57	778353	Spur Gear (17 teeth)
20	792077A	Ball 5 / 6" dia	58	778351	Spur Gear (21 teeth)
21	792078	Set Screw 3 / 8-16 x 3 / 8"	59	778349	Spur Gear (24 teeth)
22	792079	Spring .310 OD x .625 L	60	778345	Spur Gear (25 teeth)
25	792073A	Screw 1/4 - 20 x 1-1 / 4"	63	786071	Countershaft Spacer 1 - 1 / 8" x 3 / 8"
25A	792177	Screw 1 / 4 - 20 x 1 - 3 / 8"	64	786072	Brake Shaft Spacer 1 - 3 / 8" x 3 / 8"
26	792125	Retaining Ring (pkg of 2)	65	780189	Flat Washer .563 ID x .062W
27	792035	Retaining Ring	66	776422	Input shaft
28	788040	Retaining Ring	67	776396	Shifter & Brake shaft
29	780072	Thrust Washer .627 ID x .031W	69	792170	Retaining Ring
29A	780160	Thrust Washer .563 ID x .031W	70	786187	Spacer .890
29B	780051	Thrust Washer .762 ID x .031W	71	788069	Square Cut Ring
29C	780199	Anti -Rotation Washer .632	71B	788092	"O" Ring
30	780108	Cup Washer 1.127 ID x .032W	76	780090	Flat Washer 1.128 ID x .058W
31	780001	Flat Washer .750 ID x .056 (Use as Needed)	77	788078A	Inverted Retaining Ring
31A	780195	Flat Washer .750 ID x .062W	79	792144	Spring .430 OD x .5000 L
32	788083	Oil Seal 5 / 8"	82	778333	Bevel & Spur Gear (30 & 13 teeth)
34	780194	Bushing .563	83	778338	Spur Gear (27 teeth)
35	780193	Flanged Bushing 5 / 8" ID	85	792154	Oill Fill Plug
35A	780197	Flanged Bushing .751	87	788089A	Oil Seal 9 / 16"
36	790075	Brake Disk	150	788093A	Liquid Gasket RTV Silicone
37	790007	Brake Pad Plate	157	788088A	Oil Seal 3 / 4"
38	799021	Brake Pad (pkg of 2)	180	730229A	Gear Oil 80W90
			900	794711	Replacement MST-205-544C Transaxle

NOTE: All component dimensions given in U.S. inches  
1 inch = 25.4 mm

**TRACTOR - - MODEL NUMBER 917.277252  
BRIGGS ENGINE-MODEL NUMBER 282H07, TYPE NUMBER 0231-E1**

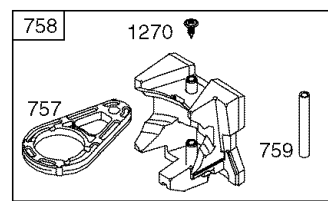
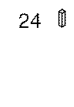
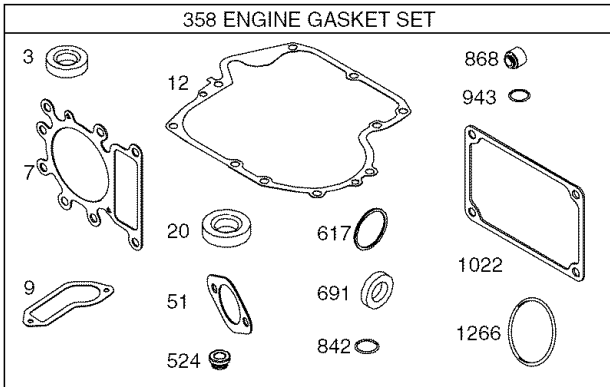
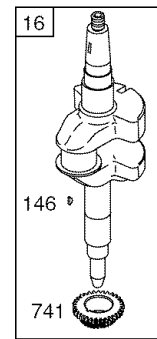
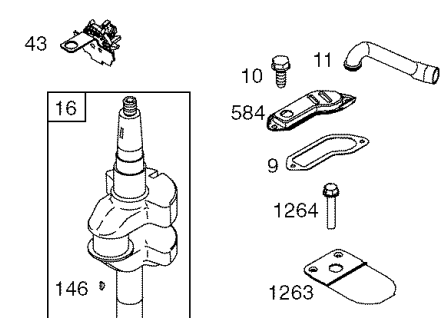
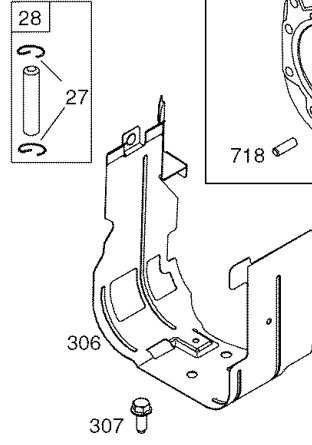
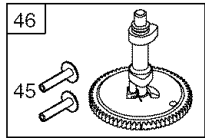
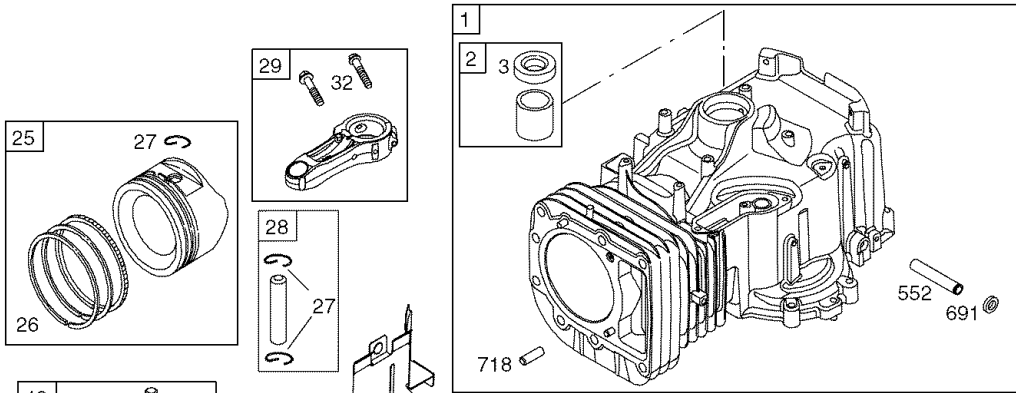

1019 LABEL KIT

1058 OWNER'S MANUAL

1036 EMISSION LABEL

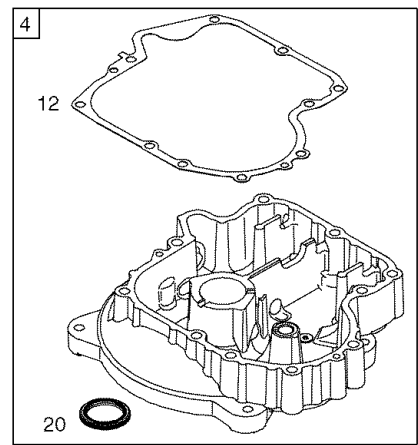

282H07-0231-E1



**TRACTOR - - MODEL NUMBER 917.277252**  
**BRIGGS ENGINE-MODEL NUMBER 282H07, TYPE NUMBER 0231-E1**

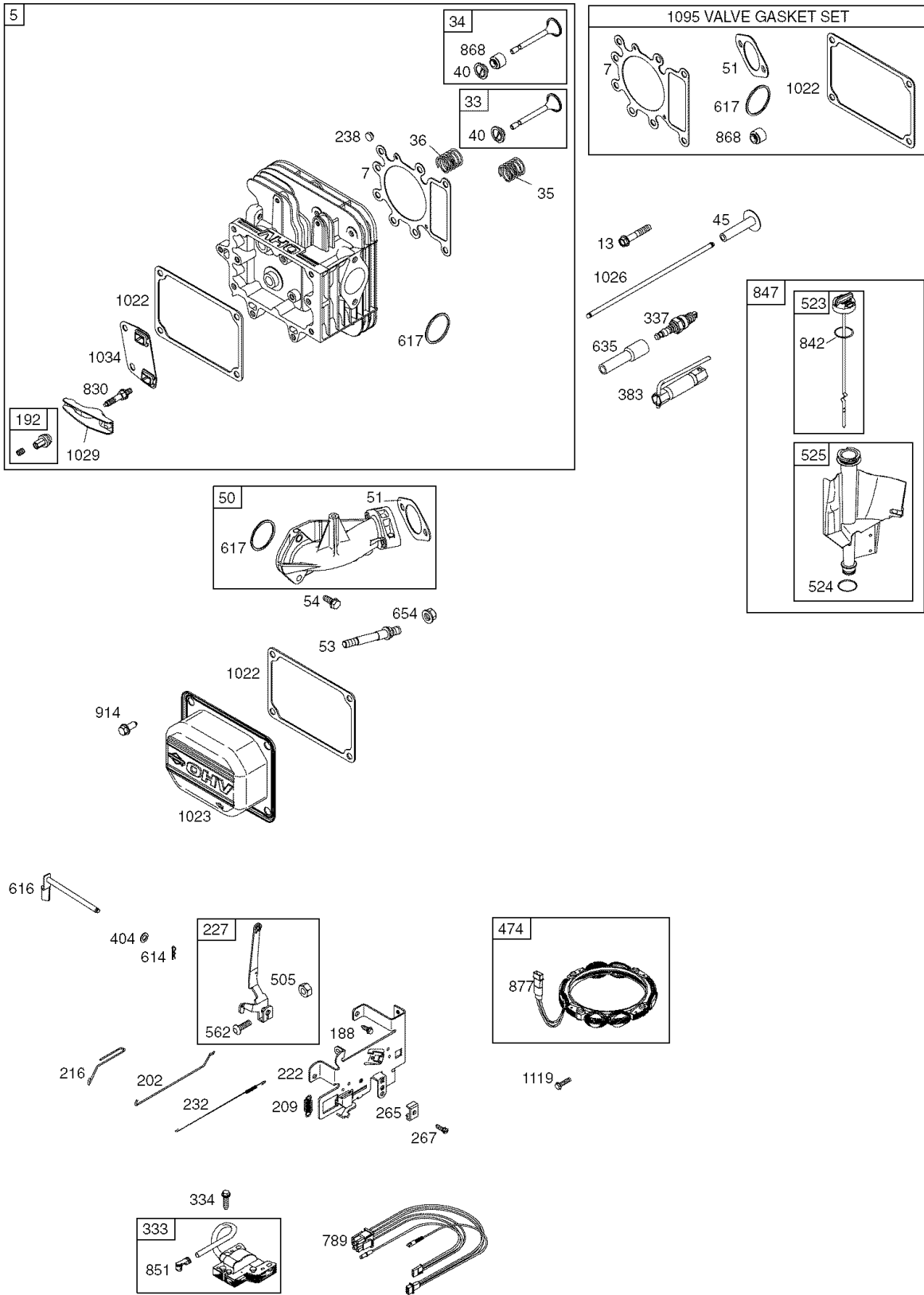

282H07-0231-E1

**TRACTOR - - MODEL NUMBER 917.277252  
BRIGGS ENGINE-MODEL NUMBER 282H07, TYPE NUMBER 0231-E1**

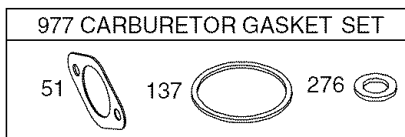
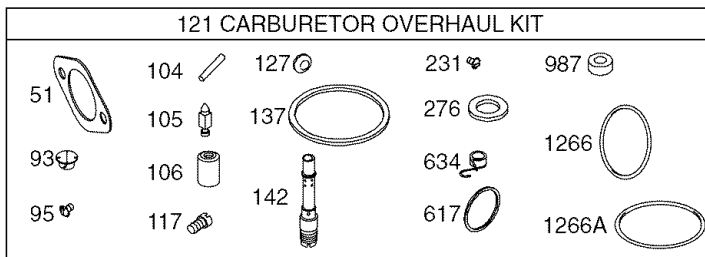
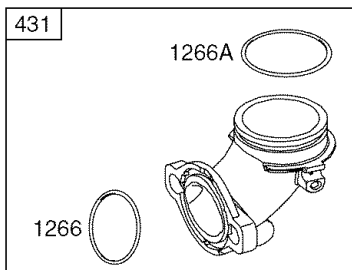
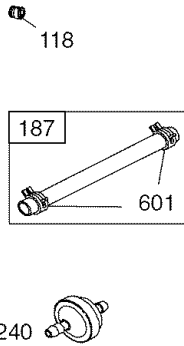
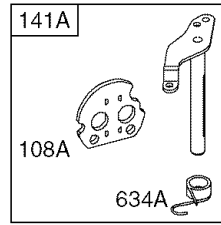
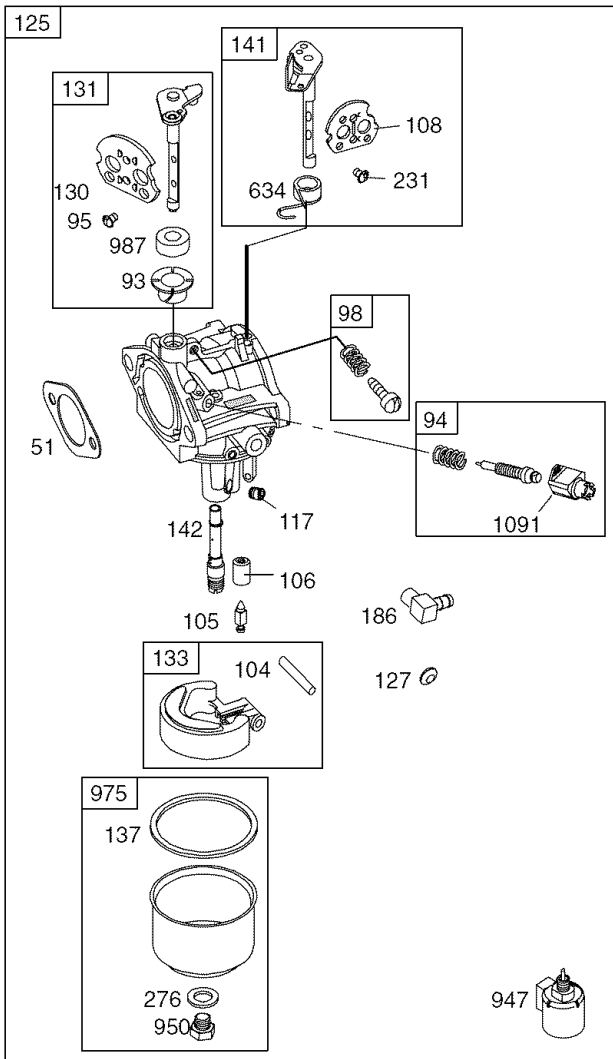

**TRACTOR - - MODEL NUMBER 917.277252  
BRIGGS ENGINE-MODEL NUMBER 282H07, TYPE NUMBER 0231-E1**

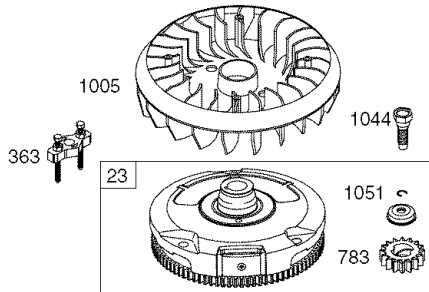
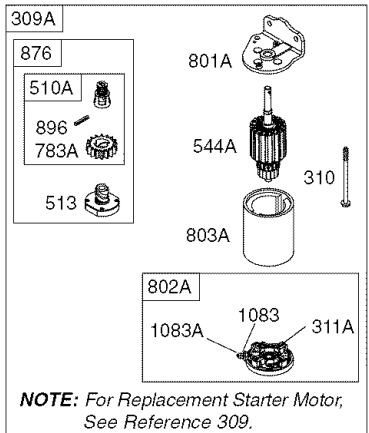
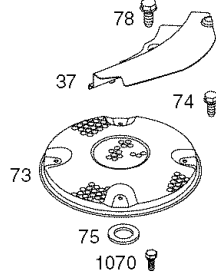
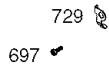
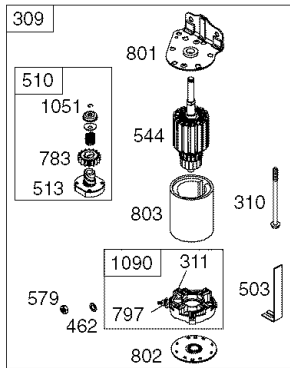
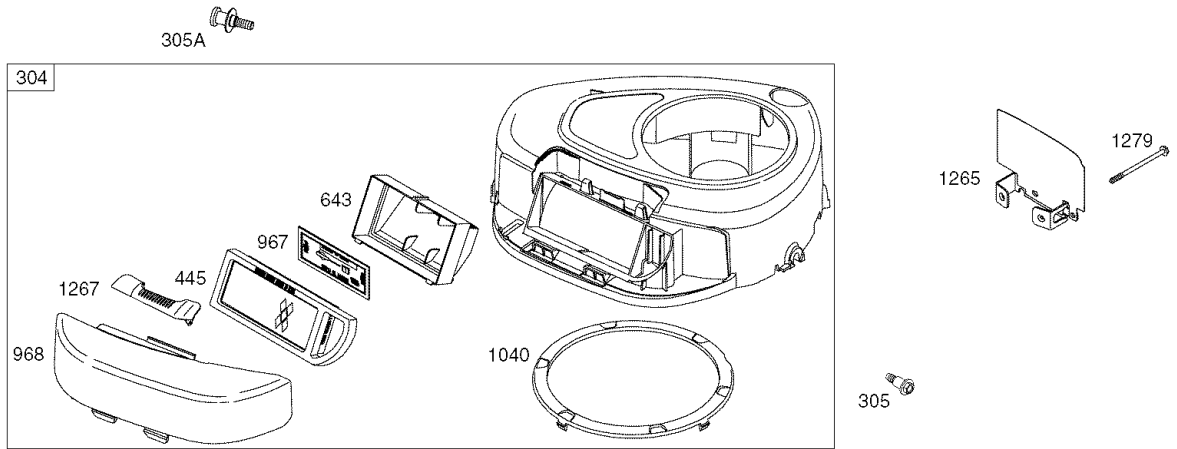

282H07-0231-E1

**TRACTOR - - MODEL NUMBER 917.277252**  
**BRIGGS ENGINE-MODEL NUMBER 282H07, TYPE NUMBER 0231-E1**

KEY NO.	PART NO.	DESCRIPTION	KEY NO.	PART NO.	DESCRIPTION
1	697132	Cylinder Assembly	137	281165	Ø± Gasket-Float Bowl
2	399265	Kit-Bushing/Seal (Magneto Side)	141	495097	Kit-Choke Shaft (Manual Choke)
3	391086	• Seal-Oil (Magneto Side)	141A	495931	Kit-Choke Shaft (Choke A Matic)
4	697106	Sump-Engine	142	697140	Ø Nozzle-Carburetor
5	698148	Head-Cylinder	146	691639	Key-Timing
7	273280	•+ Gasket-Cylinder Head	186	692317	Connector-Hose
9	697109	• Gasket-Breather	187	691050	Line-Fuel (Cut to Required Length)
10	697157	Screw (Breather Assembly)	188	691693	Screw (Control Bracket)
11	697113	Tube-Breather	192	691986	Adjuster-Rocker Arm
12	697110	• Gasket-Crankcase	202	691841	Link-Mechanical Governor
13	690360	Screw (Cylinder Head)	209	692208	Spring-Governor
15	690946	Plug-Oil Drain	216	691840	Link-Choke
16	697127	Crankshaft	222	694042	Bracket-Control
20	690947	• Seal-Oil (PTO Side)	227	691374	Lever-Governor Control
22	692125	Screw (Crankcase Cover/Sump)	231	691636	Screw (Choke Valve)
23	693557	Flywheel	232	691842	Spring-Governor
24	222698	Key-Flywheel	238	691843	Cap-Valve
25	697114	Piston Assembly (Standard)	240	394358	Filter-Fuel
	697116	Piston Assembly (.010" Over-size)	265	691024	Clamp-Casing
	697117	Piston Assembly (.020" Over-size)	267	695134	Screw (Casing Clamp)
	697118	Piston Assembly (.030" Over-size)	276	692255	Ø± Washer-Sealing
26	697115	Ring Set (Standard)	304	698402	Housing-Blower
	697119	Ring Set (.010" Oversize)	305	697102	Screw (Blower Housing)
	697120	Ring Set (.020" Oversize)	305A	697103	Screw (Blower Housing)
	697121	Ring Set (.030" Oversize)	306	697107	Shield-Cylinder
27	697100	Lock-Piston Pin	307	691003	Screw (Cylinder Shield)
28	697099	Pin-Piston	309	693551	Motor-Starter
29	697126	Rod-Connecting (Standard)	309A	---	Motor-Starter (For Replacement Starter)
32	692852	Screw (Connecting Rod)	310	690323	Motor, See Reference 309)
33	495856	Valve-Exhaust	311	497608	Bolt (Starter Motor)
34	495857	Valve-Intake	311A	395538	Brush Set
35	691279	Spring-Valve (Intake)	333	492341	Brush Set
36	691279	Spring-Valve (Exhaust)	334	691061	Armature-Magneto
37	697352	Guard-Flywheel	337	491055	Screw (Magneto Armature)
40	691752	Retainer-Valve	358	697151	Plug-Spark
43	691968	Slinger-Governor/Oil	363	19203	Gasket Set-Engine
45	690564	Tappet-Valve	383	89838	Flywheel Puller
46	697687	Camshaft	404	691691	Wrench-Spark Plug
48	697761	Short Block (31C707-0230-E2 Replacement Engine-art not available)	431	697122	Washer (Governor Crank)
50	690193	Manifold-Intake	445	698083	Elbow-Intake
51	692137	•Ø±+ Gasket-Intake	462	691261	Filter-Air Cleaner Cartridge
53	690227	Stud (Carburetor)	474	696459	Washer (Starter Cable)
54	691148	Screw (Intake Manifold)	503	691532	Alternator
73	697384	Screen-Rotating	505	691251	Strap-Starter
74	697987	Screw (Rotating Screen)	510	693699	Nut (Governor Control Lever)
75	690582	Washer (Flywheel)	510A	497606	Drive-Starter
78	691003	Screw (Flywheel Guard)	513	692024	Drive-Starter
93	690602	Ø Bushing-Throttle Shaft	513	692024	Clutch-Drive
94	498030	Kit-Idle Mixture	523	697086	Dipstick
95	691636	Screw (Throttle Valve)	524	691032	• Seal-Dipstick Tube
98	495800	Kit-Idle Speed	525	697184	Tube-Dipstick
104	690525	Ø Pin-Float Hinge			RPM Settings: Low Speed: 1900-2100
105	231855	Ø Valve-Float Needle			High Speed: 3000-3200
106	690577	Ø Seat-Inlet			
108	690464	Valve-Choke (Manual Choke)	•		Included in Engine Gasket Set, Key. No. 358
108A	692344	Valve-Choke (Choke A Matic)	Ø		Included in Carburetor Overhaul Kit, Key. No. 121
117	694352	Ø Jet-Main (Standard)	±		Included in Carburetor Gasket Set, Key. No. 977
118	697492	Jet-Main (High Altitude)	+		Included in Valve Gasket Set, Key. No. 1095
121	697241	Kit-Carburetor Overhaul			
125	697190	Carburetor			
127	695005	Plug-Welch			
130	691750	Valve-Throttle			
131	494379	Kit-Throttle Shaft			
133	494381	Float-Carburetor			

**NOTE:** All component dimensions given in U.S. inches  
1 inch = 25.4 mm

**TRACTOR - - MODEL NUMBER 917.277252  
BRIGGS ENGINE-MODEL NUMBER 282H07, TYPE NUMBER 0231-E1**

KEY NO.	PART NO.	DESCRIPTION	KEY NO.	PART NO.	DESCRIPTION
544	692034	Starter-Armature	968	698403	Cover-Air Cleaner
544A	390837	Starter-Armature	975	495933	Bowl-Float
552	697144	Bushing-Governor Crank	977	690192	Gasket Set-Carburetor
562	691119	Bolt (Governor Control Lever)	987	691326	ØSeal-Throttle Shaft
579	691029	Nut (Starter Cable)	1005	697853	Fan-Flywheel
584	697112	Cover-Breather Passage	1019	697143	Kit-Label
601	95162	Clamp-Hose	1022	272475	•+Gasket-Rocker Cover
614	691620	Pin-Cotter	1023	692492	Cover-Rocker Arm
616	692012	Crank-Governor	1026	692003	Rod-Push (Intake)
617	692138	Ø • Seal-O Ring (Intake Manifold)	692011		Rod-Push (Exhaust)
634	690801	ØSpring/Seal Assembly (Manual Choke)	1029	691751	Arm-Rocker
			1034	690822	Guide-Push Rod
634A	690802	ØSpring/Seal Assembly (Choke A Matic)	1036	695700	Label-Emission
			1040	698368	Plate-Trim
635	691909	Boot-Spark Plug	1044	691658	Screw (Flywheel)
643	698401	Retainer-Air Filter	1051	691265	Ring-Retaining
654	690958	Nut (Carburetor)	1058	275038	Owner's Manual
691	692407	• Seal-Governor Shaft	1070	690372	Screw (Flywheel Fan)
697	690372	Screw (Drive Cap)	1083	691626	Nut (Starter Terminal)
718	690959	Pin-Locating	1083A	690958	Nut (Starter Terminal)
729	691224	Clip-Wire	1090	691293	Retainer-Brush
741	697128	Gear-Timing	1091	691333	Cap-Limiter
757	697607	Link-Counterweight	1095	691581	Gasket Set-Valve
758	697134	Counterweight	1119	691183	Screw (Alternator)
759	697392	Pin-Counterweight	1263	697124	Reed-Breather
783	693713	Gear-Pinion	1264	697104	Screw (Breather Reed)
783A	693059	Gear-Pinion	1265	697125	Support-Blower Housing
789	698329	Harness-Wiring	1266	691917	•ØSeal-O Ring (Intake Elbow)
797	693167	Nut (Brush Retainer)	1266A	697123	ØSeal-O Ring (Intake Elbow)
801	691283	Cap-Drive	1267	697575	Latch-Blower Housing
801A	394856	Cap-Drive	1270	697156	Plug-AVS Counterweight
802	691286	Cap-End	1279	690960	Screw (Blower Housing Support)
802A	395537	Cap-End			
803	693757	Housing-Starter			RPM Settings: Low Speed: 1900-2100
803A	398159	Housing-Starter			High Speed: 3000-3200
830	691095	Stud (Rocker Arm)			
842	691031	• Seal-O Ring (Dipstick Tube)			• Included in Engine Gasket Set, Key. No. 358
847	697611	Dipstick/Tube Assembly	Ø		Included in Carburetor Overhaul Kit, Key. No. 121
851	692424	Terminal-Spark Plug	‡		Included in Carburetor Gasket Set, Key. No. 977
868	690968	•+Seal-Valve	+		Included in Valve Gasket Set, Key. No. 1095
876	495877	Kit-Pinion Spring			
877	393456	Wire-Connector/Alternator			
896	691641	Pin-Drive Retainer			
914	690960	Screw (Rocker Cover)			
947	694393	Solenoid-Fuel			
950	691657	Screw (Float Bowl)			
967	697015	Filter-Pre Cleaner			

**NOTE:** All component dimensions given in U.S. inches  
1 inch = 25.4 mm

## SERVICE NOTES

## SUGGESTED GUIDE FOR SIGHTING SLOPES FOR SAFE OPERATION

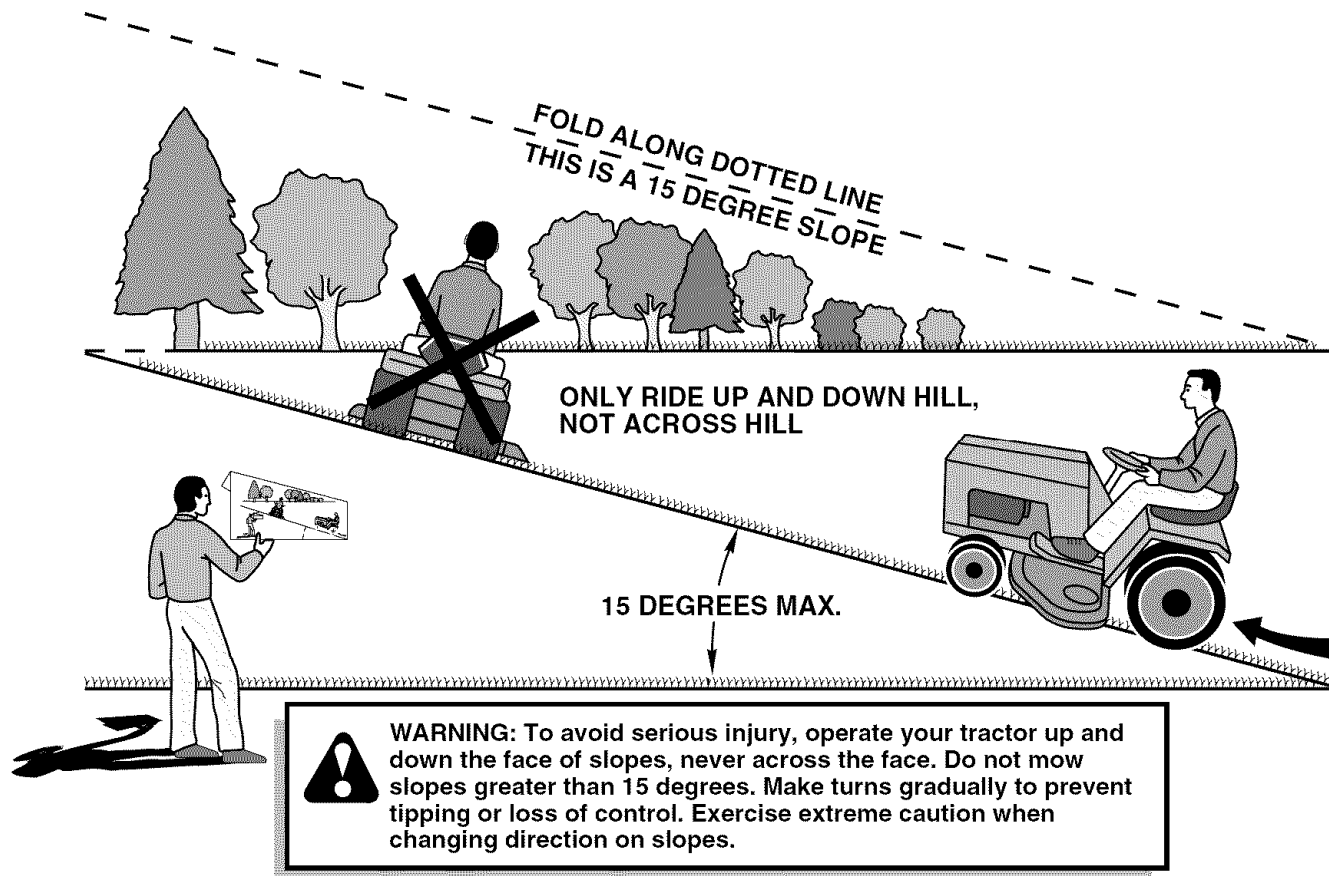

1. Fold this page along dotted line indicated above.
2. Hold page before you so that its left edge is vertically parallel to a tree trunk or other upright structure.
3. Sight across the fold in the direction of hill slope you want to measure.
4. Compare the angle of the fold with the slope of the hill.

# Get it fixed, at your home or ours!

## Your Home

For repair – **in your home** – of **all** major brand appliances, lawn and garden equipment, or heating and cooling systems, **no matter who made it, no matter who sold it!**

For the replacement parts, accessories and owner's manuals that you need to do-it-yourself.

For Sears professional installation of home appliances and items like garage door openers and water heaters.

**1-800-4-MY-HOME<sup>®</sup>** Anytime, day or night  
(1-800-469-4663) (U.S.A. and Canada)  
[www.sears.com](http://www.sears.com) [www.sears.ca](http://www.sears.ca)

## Our Home

For repair of carry-in products like vacuums, lawn equipment, and electronics, call or go on-line for the nearest **Sears Parts and Repair Center.**

**1-800-488-1222** Anytime, day or night (U.S.A. only)  
[www.sears.com](http://www.sears.com)

To purchase a protection agreement (U.S.A.)  
or maintenance agreement (Canada) on a product serviced by Sears:

**1-800-827-6655** (U.S.A.) **1-800-361-6665** (Canada)

Para pedir servicio de reparación  
a domicilio, y para ordenar piezas:

**1-888-SU-HOGAR<sup>SM</sup>**  
(1-888-784-6427)

Au Canada pour service en français:

**1-800-LE-FOYER<sup>MC</sup>**  
(1-800-533-6937)  
[www.sears.ca](http://www.sears.ca)

# SEARS

02410

© Sears, Roebuck and Co.

® Registered Trademark / ™ Trademark / <sup>SM</sup> Service Mark of Sears, Roebuck and Co.

® Marca Registrada / ™ Marca de Fábrica / <sup>SM</sup> Marca de Servicio de Sears, Roebuck and Co.

<sup>MC</sup> Marque de commerce / <sup>MD</sup> Marque déposée de Sears, Roebuck and Co.