

Operators Manual

CRAFTSMAN®

5.5 H.P.

SOFT TOP VAC SYSTEM AND CART

Model No. 486.245041

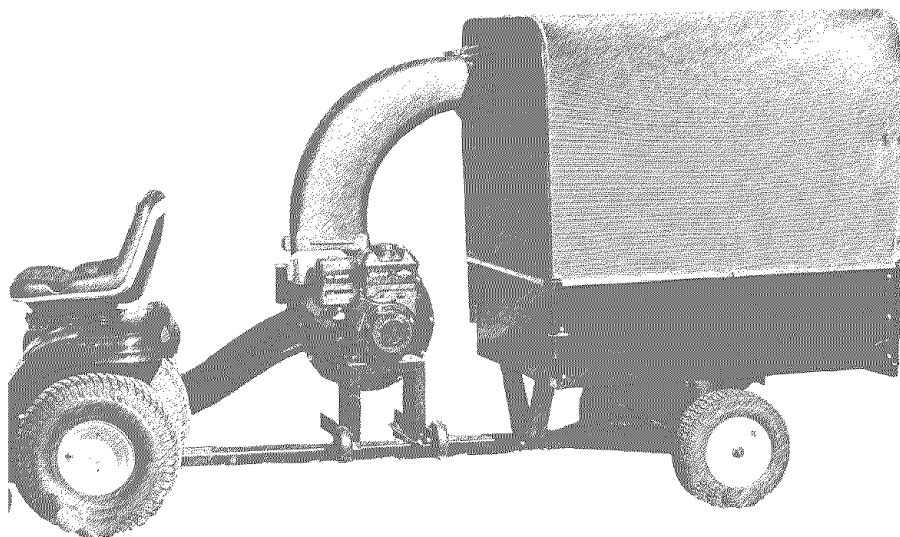

CAUTION:

Before using this product, read this manual and follow all Safety Rules and Operating Instructions.

- Safety
- Assembly
- Operation
- Maintenance
- Parts

IMPORTANT - READ THIS FIRST!!!

For Missing Parts or Assembly Questions

Please Call 866-576-8388

Mon.-Fri. 7 am - 5 pm CST.

FAX 217-728-2032 or e-mail info@agri-fab.com

Missing parts will be sent UPS in 24 hours directly to your home.

SEARS, ROEBUCK AND CO., HOFFMAN ESTATES, IL 60179 U.S.A.
WWW.SEARS.COM/CRAFTSMAN

TABLE OF CONTENTS

WARRANTY	2	MAINTENANCE	20
SAFETY RULES.....	3	STORAGE	21
ACCESSORIES AND ATTACHMENTS	5	TROUBLESHOOTING.....	21
FULL SIZE HARDWARE CHART	6	REPAIR PARTS ILLUSTRATIONS	23,24,26
CARTON CONTENTS.....	8	REPAIR PARTS LISTS	23,25,26
ASSEMBLY.....	9	SLOPE GUIDE	27
OPERATION.....	18	PARTS ORDERING/SERVICE	Rear Cover

WARRANTY

LIMITED WARRANTY ON CRAFTSMAN POWERED TRACTOR ATTACHMENTS

For one (1) year from the date of purchase, if this Craftsman Equipment is maintained, lubricated and tuned up according to the instructions in the owner's manual, Sears will repair or replace free of charge any parts found to be defective in material or workmanship. Warranty service is available free of charge by returning your Craftsman equipment to your nearest Sears Service Center. In-home warranty service is available but a trip charge will apply. This Warranty applies only while this product is in the United States.

This Warranty does not cover:

- Expendable items which become worn during normal use, such as spark plugs, air cleaners, belts, and oil filters.
- Tire replacement or repair caused by punctures from outside objects, such as nails, thorns, stumps, or glass.
- Repairs necessary because of operator abuse, including but not limited to, damage caused by impacting objects that bend the frame or crankshaft, or over-speeding the engine.
- Repairs necessary because of operator negligence, including but not limited to, electrical and mechanical damage caused by improper storage, failure to use the proper grade and amount of engine oil, or failure to maintain the equipment according to the instructions contained in the owner's manual.
- Engine (fuel system) cleaning or repairs caused by fuel determined to be contaminated or oxidized (stale). In general, fuel should be used **within 30 days** of its purchase date.
- Equipment used for commercial or rental purposes.

LIMITED WARRANTY ON BATTERY

For ninety (90) days from date of purchase, if any battery included with the equipment proves defective in material or workmanship and our testing determines the battery will not hold a charge, Sears will replace the battery at no charge. Warranty service is available free of charge by returning your Craftsman equipment to your nearest Sears Service Center. In-home warranty service is available but a trip charge will apply. This Warranty applies only while this product is in the United States.

TO LOCATE THE NEAREST SEARS SERVICE CENTER OR TO SCHEDULE SERVICE,
SIMPLY CONTACT SEARS AT 1-800-4-MY-HOME.

This warranty gives you specific legal rights, and you may also have other rights, which vary from state to state.



SAFETY



Any power equipment can cause injury if operated improperly or if the user does not understand how to operate the equipment. Exercise caution at all times when using power equipment.

- Read and follow all instructions in this manual before attempting to assemble or operate this equipment. Failure to comply with these instructions may result in personal injury. Keep this manual in a safe place for future reference and for ordering replacement parts.
- Read this operating and service instruction manual carefully. Be thoroughly familiar with the controls and proper use of this power vacuum.
- Read the vehicle owners manual and vehicle safe operation rules before using this equipment.
- Never allow children under 16 to operate this Vac System. Children 16 years and older should only operate under close parental supervision.
- Do not allow anyone to operate this equipment without proper instructions.
- Do not allow passengers to ride on this equipment or on the towing vehicle.
- Keep the area of operation clear of all persons, particularly small children. Also keep area clear of pets.
- Check fuel before starting engine. Do not fill fuel tank indoors, or when engine is running, or while engine is hot. Wipe off any spilled fuel before starting engine.
- Engine and muffler get hot. Do not touch! To avoid fire hazard, keep clean of debris and other accumulations.
- Never store Vac System with fuel in tank. Allow engine to cool before storing in any enclosure.
- Do not change engine governor settings.
- Do not operate engine if air cleaner or cover is removed, except for adjustment. Removal of these parts could create a fire hazard.
- Keep hands, feet, face, long hair and clothing out of inlet and discharge area. There are ROTATING BLADES inside these openings.
- Before cleaning, repairing or inspecting, make certain all moving parts come to a complete stop. Disconnect spark plug wire and keep wire away from plug to prevent accidental starting. Keep throttle control lever in stop position.
- If the Vac System should become blocked with debris at any point, shut engine off and wait until the impeller comes to a complete stop before attempting to remove the obstruction. Disconnect spark plug wire to prevent accidental starting.
- If the cutting mechanism strikes a foreign object, or if your Mow-n-vac should start to vibrate abnormally, stop the engine immediately, disconnect the spark plug wire and move the wire away from the spark plug. Allow the machine to stop and take the following steps.
 - a. Inspect for damage.
 - b. Repair or replace any damaged parts.
 - c. Check for loose parts and tighten to assure continued safe operation.
- Check all bolts for tightness at frequent intervals to help insure safe operation.
- Check top cover frequently for wear. Replace if worn or damaged.
- Never operate Mow-N-Vac unless deck adapter, hose, hose adapter (nozzle), discharge chute (elbow), and top cover are properly attached in their place.
- Do not remove top cover or attempt to empty contents of cart while engine is running.
- Never attempt to change hose adapter (nozzle) or to install remote hose attachment when engine is running.
- Keep all shields and guards (e.g. discharge chute (elbow) and hose adapter (nozzle) in place and securely attached.
- Always wear safety glasses or other suitable eye protection when operating or maintaining this equipment.
- Do not stand behind cart in exhaust discharge area while engine is running.
- Do not operate this equipment while intoxicated or while taking drugs or medication that impairs the senses and reactions.
- When using this equipment, start with the vehicle transmission in first (low) gear and then gradually increase speed only as conditions permit.
- Operate this equipment at reduced speed on rough terrain, along creeks and ditches and on slopes to prevent tipping or loss of control. Do not drive too close to a creek or ditch.
- Vehicle braking and stability are affected by the addition of this equipment. Do not fill the Mow-N-Vac to its full capacity without checking the capability of the towing vehicle to safely pull and stop with the Mow-N-Vac attached.
- Before operating on any grade (hill) refer to the safety rules in the vehicle owner's manual concerning safe operation on slopes. Also refer to the SLOPE GUIDE on page 27 of this owner's manual. Do not operate on slopes in excess of 10 degrees. **STAY OFF STEEP SLOPES.**
- Follow the maintenance instructions outlined in this manual.



Look for this symbol to point out important safety precautions. It means--**Attention!! Become alert!! Your safety is involved.**



DANGER: This Vac System was built to be operated according to the rules for safe operation in this manual. As with any type of power equipment, carelessness or error on the part of the operator can result in serious injury. This unit is capable of amputating fingers and hands and throwing objects. Failure to observe the following safety instructions could result in serious injury or death.

WARNING

TO AVOID SERIOUS INJURY

- Read Owner's Manual and all safety labels on machine before starting and using machine.
- Do Not remove top cover or attempt to empty contents of cart while engine is running.
- Do Not stand behind cart in exhaust discharge area while engine is running.
- Keep hands, feet, face, long hair and clothing out of chipper inlet, vac inlet, and discharge area. There are ROTATING BLADES inside these openings.
- Wear approved safety glasses and gloves. Avoid loose fitting clothes.
- Keep the area of operation clear of all persons, particularly small children and pets.
- Keep all shields and guards (e.g. upper chipper chute extension, discharge chute, nozzle assembly) in place and securely attached.
- Check discharge boot frequently for wear. Replace if worn or damaged.
- If unit becomes clogged or jammed, shut off engine right away. Do Not attempt to clear clog or jam with engine running.
- Muffler and engine get hot and can cause burns. Do Not Touch. To avoid a fire hazard, keep leaves, grass and other combustible debris off hot muffler and engine.
- Do Not attempt to remove or attach vac nozzle or optional Hose Kit with engine running.
- Do Not operate unit unless nozzle or optional Hose Kit is secured in place.
- Do Not fill gas tank while engine is running. Allow engine to cool at least 2 minutes before refueling.

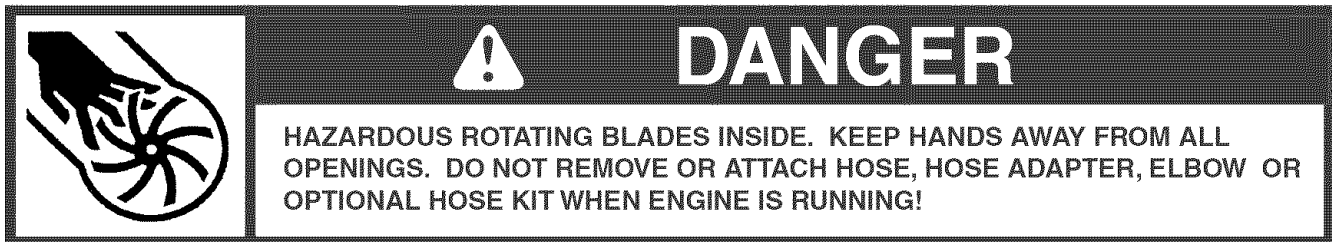

WARNING

This unit is equipped with an internal combustion engine and should not be used on or near unimproved forest-covered, or grass-covered land unless the engine's exhaust system is equipped with a spark arrester meeting applicable local or state laws (if any). If a spark arrester is used, it should be maintained in effective working order by the operator.

In the State of California the above is required by law (Section 4442 of the California Public Resources Code). Other states may have similar laws. Federal laws apply on federal lands. A spark arrester muffler is available at your nearest engine authorized service center.

ACCESSORIES AND ATTACHMENTS

THESE ACCESSORIES WERE AVAILABLE WHEN THE UNIT WAS PURCHASED. THEY ARE ALSO AVAILABLE AT MOST SEARS RETAIL OUTLETS AND SERVICE CENTERS. MOST SEARS STORES CAN ORDER REPAIR PARTS FOR YOU WHEN YOU PROVIDE THE MODEL NUMBERS OF YOUR TRACTOR AND VAC SYSTEM.

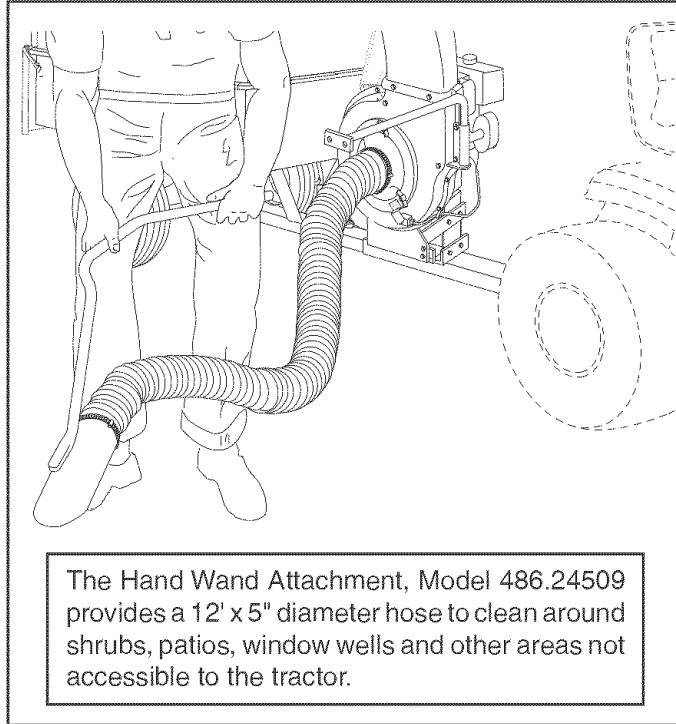

The model and serial numbers will be found on a decal attached to the engine base.

You should record both the serial number and the date of purchase and keep in a safe place for future reference.

MODEL NUMBER: 486.245041

SERIAL NUMBER: _____

DATE OF PURCHASE: _____

HARDWARE PACKAGE CONTENTS

SHOWN FULL SIZE

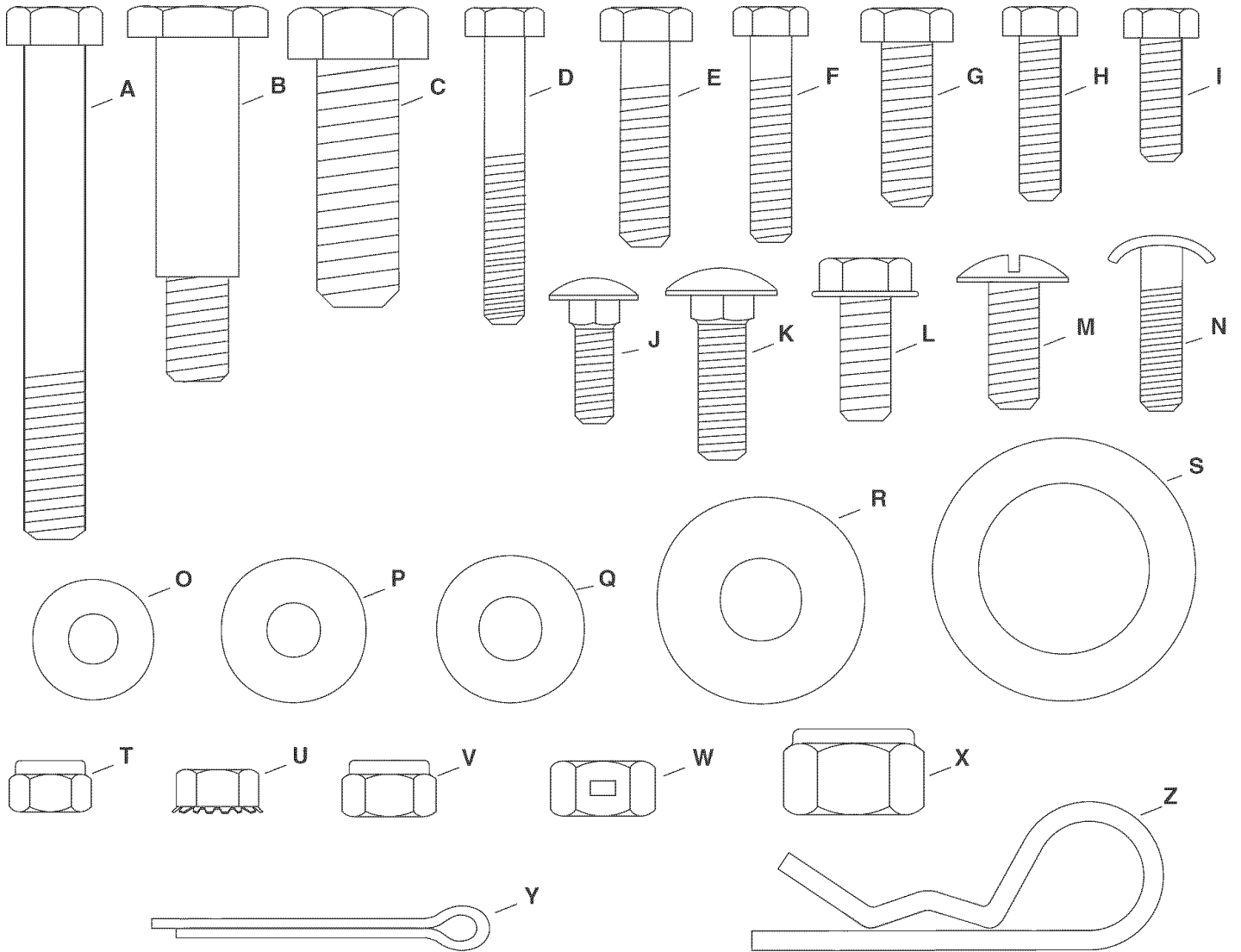

NOT SHOWN FULL SIZE

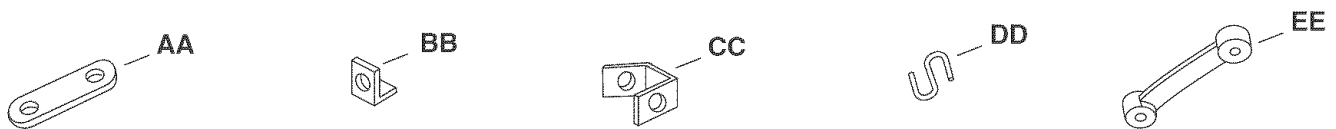

ATTENTION! Keep contents of each hardware package separate for easier assembly.

CONTENTS OF LARGE VAC HARDWARE PACKAGE

Ref.	Qty.	Description	Ref.	Qty.	Description
A	3	Hex Bolt, 3/8" x 3"	O	2	Flat Washer, 1/4"
B	2	Shoulder Bolt	P	4	Nylon Washer
C	1	Hex Bolt, 1/2" x 1-1/2"	R	1	Flat Washer, 7/16"
D	2	Hex Bolt, 1/4" x 1-3/4"	S	4	Flat Washer, 1"
F	4	Hex Bolt, 1/4" x 1-1/4"	T	35	Nylock Nut, 1/4"
G	4	Hex Bolt, 5/16" x 1"	U	2	Hex Nut, 1/4" (SEMS)
I	25	Hex Bolt, 1/4" x 3/4"	V	16	Nylock Nut, 5/16"
J	4	Carriage Bolt, 1/4" x 3/4"	W	5	Hex Lock Nut, 3/8"
L	4	Hex Bolt, 5/16" x 3/4" Thread Forming	X	1	Nylock Nut, 1/2"
M	12	Bolt, Truss Head 5/16" x 3/4"	Y	2	Pin, Cotter 1/8" x 1-1/2"
N	2	Bolt, Curved Head 1/4" x 1"	Z	1	Hair Cotter Pin, 1/8"

CONTENTS OF SMALL DECK ADAPTER HARDWARE PACKAGE

Not all parts in this bag will be used.

Ref.	Qty.	Description
E	2	Hex Bolt, 5/16" x 1-1/4"
F	2	Hex Bolt, 1/4" x 1-1/4"
H	4	Hex Bolt, 1/4" x 1"
K	2	Carriage Bolt, 5/16" x 1"
O	4	Flat Washer, 1/4"
P	5	Nylon Washer
Q	12	Flat Washer, 5/16"
T	4	Nylock Nut, 1/4"
V	3	Nylock Nut, 5/16"
AA	1	Mounting Strap
BB	1	Angle Bracket
CC	1	Mounting Bracket
DD	2	"S" Hook
EE	2	Tarp Strap

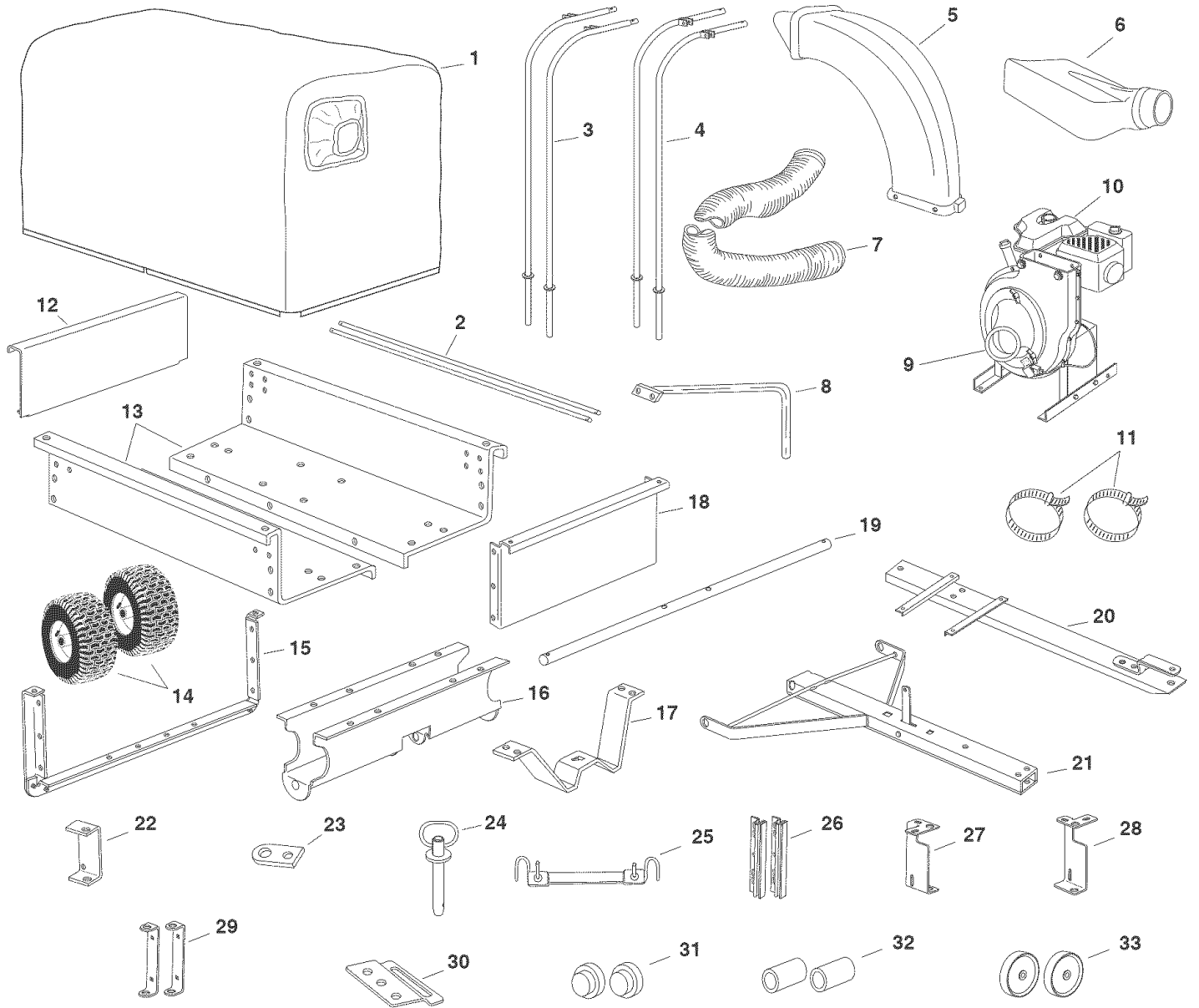

CARTON CONTENTS

Ref.	Qty.	Description	Ref.	Qty.	Description
1	1	Cover	17	1	Latch Stand Bracket
2	2	Top Connecting Tube	18	1	Front Panel
3	2	Support Tube, R.H.	19	1	Axle
4	2	Support Tube, L.H.	20	1	Front Tongue
5	1	Elbow (Discharge Chute)	21	1	Rear Tongue
6	2	Deck Adapter	22	1	Hose Hanger Bracket
7	1	Hose2	23	1	Hitch Plate
8	1	Hose Hanger Rod Assembly	24	1	Hitch Pin
9	1	Hose Adapter (Nozzle)	25	1	Rubber Strap
10	1	Engine	26	2	Tailgate Guide
11	2	Hose Clamps	27	1	Front Tube Support Bracket, R.H.
12	1	Tailgate	28	1	Front Tube Support Bracket, L.H.
13	2	Cart Bodies	29	2	Rear Tube Support Bracket
14	2	Wheels	30	1	Deck Adapter Bracket
15	1	Tailgate Reinforcement Bracket	31	2	Hub Caps
16	1	Wheel Support	32	2	Wheel Spacers
			33	2	Plastic Wheels

ASSEMBLY

This unit is shipped WITHOUT GASOLINE or OIL. After assembly, see separate engine manual for proper fuel and engine oil recommendations.

TOOLS REQUIRED FOR ASSEMBLY

- (1) Screwdriver
- (1) Pliers
- (1) 3/8" Wrench
- (2) 7/16" Wrenches
- (2) 1/2" Wrenches
- (2) 9/16" Wrenches
- (1) 3/4" Wrench (2) if hitch plate in fig. 21 is used

REMOVAL OF PARTS FROM CARTONS

- Remove the hardware packs and all loose parts from the cartons.
- Lay out and identify parts shown in carton contents.
- Lay out and identify parts in the hardware packs.
- Keep contents of each hardware package separate for easier assembly.

ASSEMBLING THE MOW-N-VAC

- Place cart body halves upright on a smooth level surface such as a garage floor or a paved driveway. See figure 1.



CAUTION: Do not leave the cart unattended in upright position during assembly. A falling cart can cause personal injury! Pay close attention to the stability of the cart while it remains in an upright position. For best stability, assemble on a smooth level surface.

- Assemble cart body halves together using three 1/4" x 3/4" hex bolts and 1/4" nylock nuts as shown in figure 1. **Do not tighten yet.**

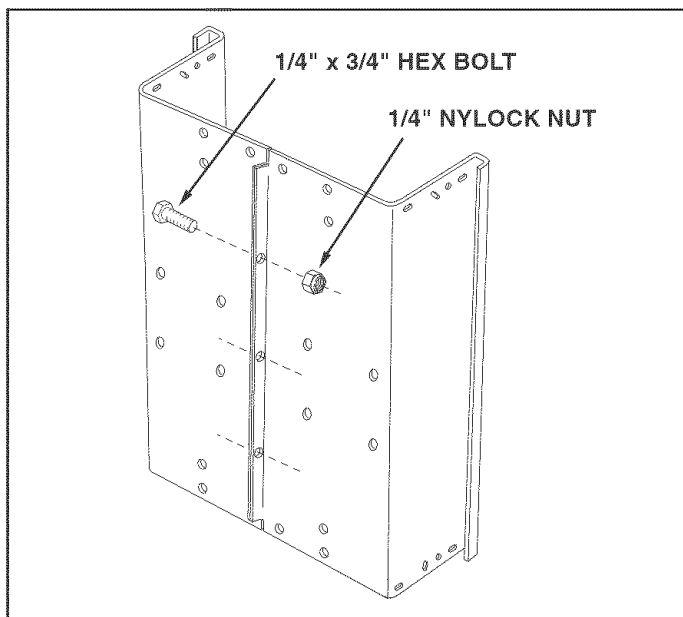

FIGURE 1

- Fit the tailgate reinforcement bracket around the end of the cart body. Fasten it to the top flanges of the cart body using two 1/4" x 3/4" hex bolts and 1/4" nylock nuts. **Do not tighten yet.** See figure 2.
- Fasten the tailgate reinforcement bracket to the bottom of the cart body using four 5/16" x 3/4" truss head bolts and 5/16" nylock nuts as shown in figure 2. **Do not tighten yet.**
- Position the tailgate guides on the inside of the cart bodies with the guide channels to the front as shown in figure 2. Fasten using six 1/4" x 3/4" hex bolts and 1/4" nylock nuts. See figure 2. **Do not tighten yet.**

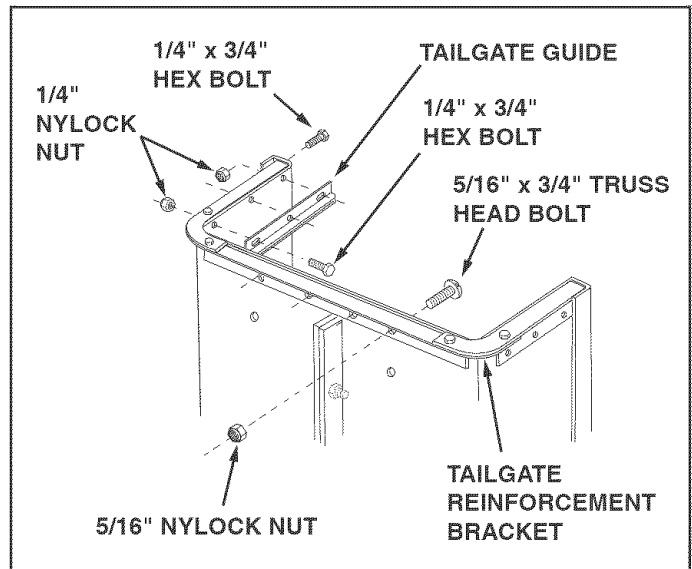

FIGURE 2

- Assemble the Rear Tube Support Brackets to the tailgate reinforcement bracket using four 1/4" x 3/4" carriage bolts and 1/4" nylock nuts. **Do not tighten yet.** See figure 3.

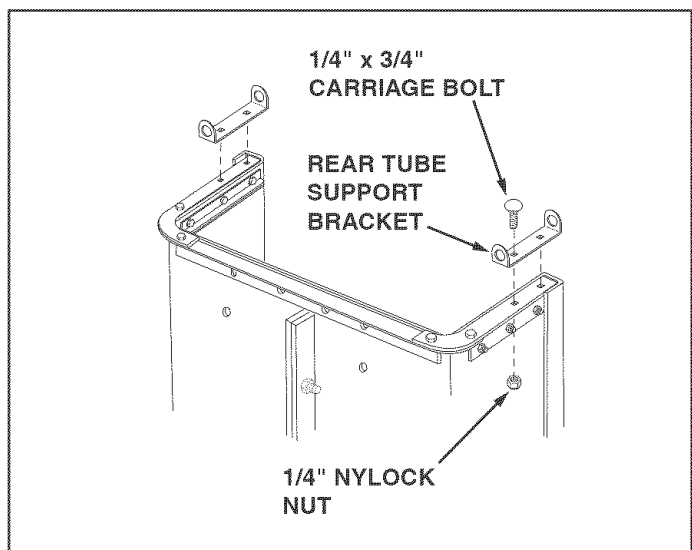

FIGURE 3

- Pull the cart body halves together.
- **Tighten** the four truss head bolts.
Tighten the six hex bolts in the sides of the cart.
Tighten the three hex bolts in the bottom of the cart, keeping the bottom aligned.
- Assemble the wheel support to the bottom of the cart using eight 5/16" x 3/4" truss head bolts and 5/16" nylock nuts as shown in figure 4. Heads of bolts go on the inside of cart. **Tighten**.

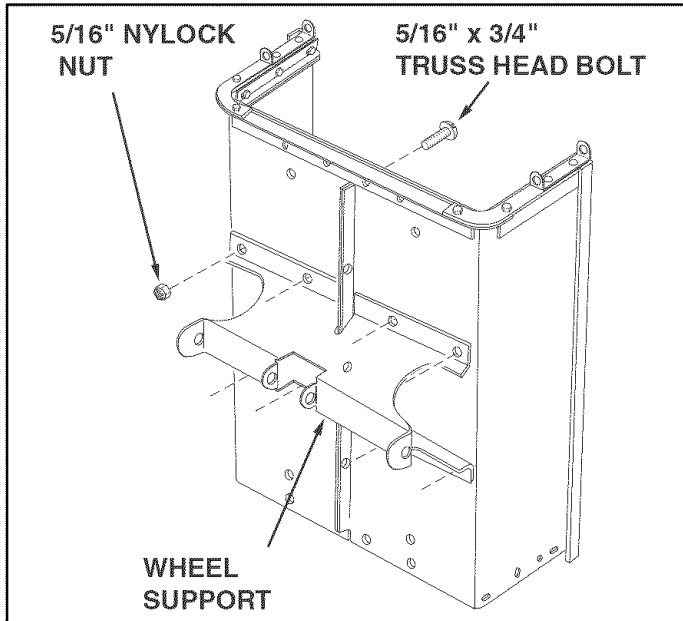

FIGURE 4

- Lay the cart down onto its top flanges.
- Align the latch stand bracket so that the tab is at the rear. Fasten the bracket to the **rear** set of holes at the front of the cart, leaving the front holes empty for now. Use two 1/4" x 3/4" hex bolts, 1/4" flat washers and 1/4" nylock nuts. Use the 1/4" flat washers as shims between the bracket and the cart bed. **Make only finger tight** at this time. See figure 5.

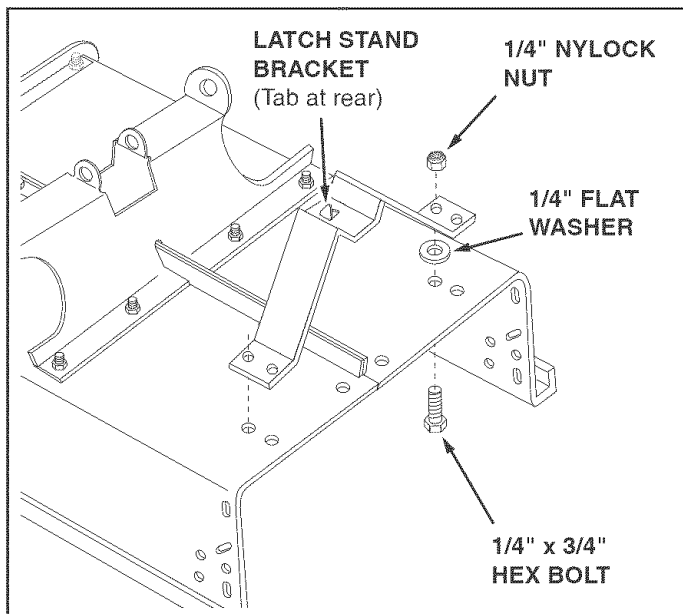

FIGURE 5

- Place the rear tongue onto the wheel support and the latch stand bracket. Assemble the axle through the wheel support and the tongue. Fasten the axle to the wheel support using two 1/4" x 1-3/4" hex bolts and 1/4" nylock nuts. See Figure 6.

IMPORTANT: Make sure the tongue is securely locked to the latch stand bracket by the latch lock lever.

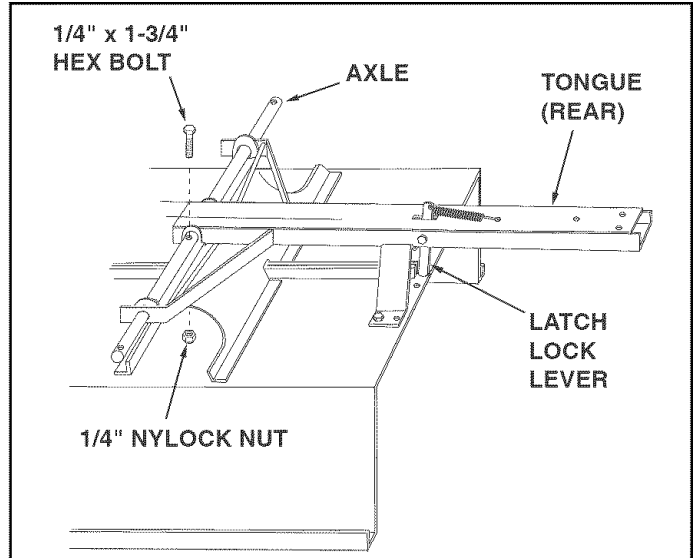

FIGURE 6

- Assemble a spacer tube onto each end of the axle as shown in figure 7.
- Assemble a 1" flat washer, a wheel (valve stem facing out), and another 1" flat washer onto the axle as shown in figure 7. Secure the wheel with a 1/8" x 1-1/2" cotter pin, spreading the ends so that a hub cap will fit over the pin. Assemble the hub cap by pressing it onto the flat washer. Repeat on other end of axle.

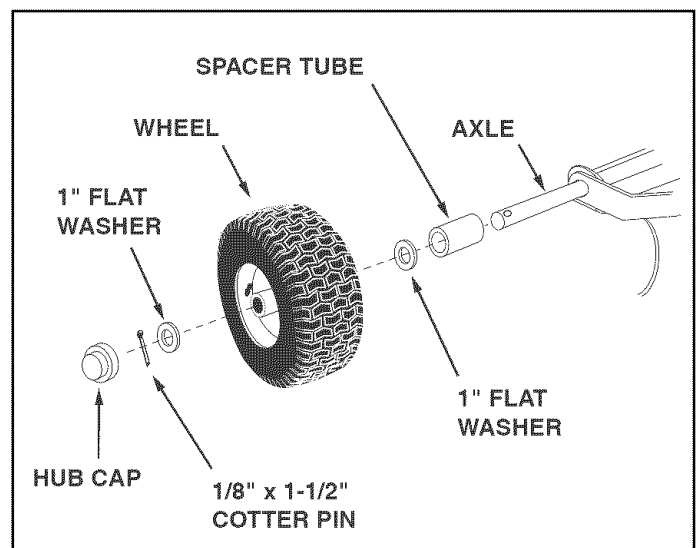

FIGURE 7

- Flip the cart over so that it rests on its wheels.
- Assemble the front tongue on top of the rear tongue using three 3/8" x 3" hex bolts and 3/8" hex lock nuts. See figure 8.

HINT: For easier assembly, support the rear tongue with a block of wood.

- Assemble the hitch pin to the hitch bracket and tongue, securing it with the 1/8" hair cotter pin. See figure 8.

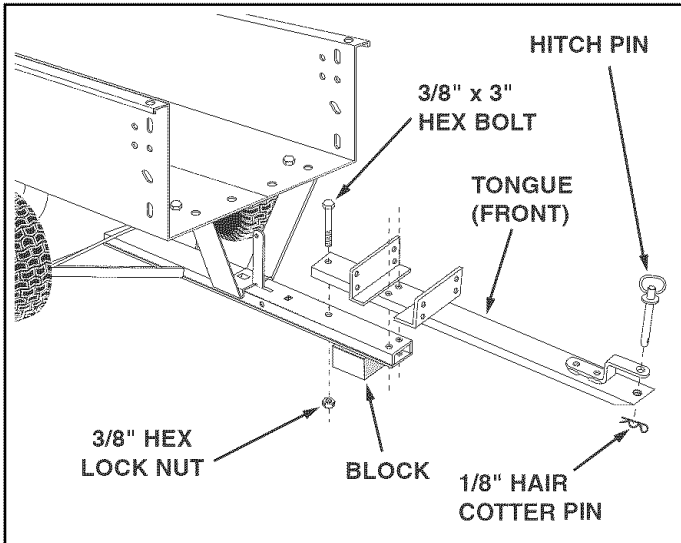

FIGURE 8

- Release the latch lock lever and tilt the cart bed back. See figure 9.
- Assemble the front panel to the cart, sliding the bottom lip of the panel between the cart and the latch stand bracket. Secure with six 1/4" x 3/4" hex bolts and 1/4" nylock nuts. Leave the upper holes on the sides empty. **Do not tighten yet.** See figure 9.

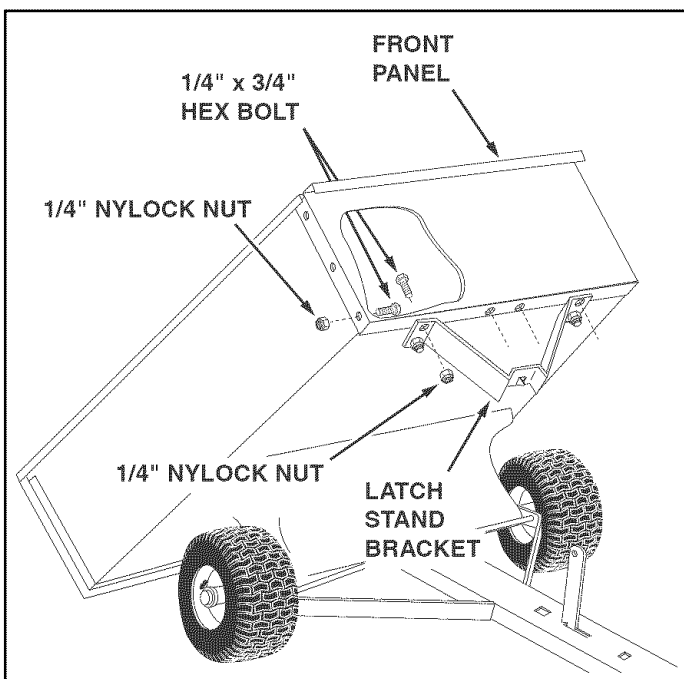

FIGURE 9

- Place the R.H. Front Tube Support Bracket under the top flanges of the cart, as shown in figure 10. Fasten the bracket to the cart using three 1/4" x 3/4" hex bolts and 1/4" nylock nuts. **Do not tighten yet.**
- Repeat for the L.H. Front Tube Support Bracket.
- **Tighten** all loose bolts and nuts.

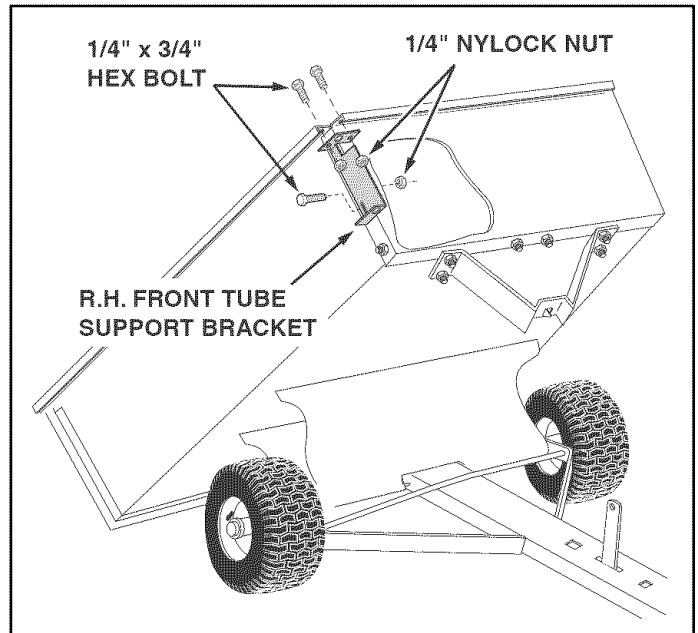

FIGURE 10

- Assemble the reduced ends of the R.H. support tubes into the ends of the L.H. support tubes. Fasten the tubes together using two 1/4" x 1" curved head bolts, inserted from the top, and two 1/4" (SEMS) hex nuts. See figure 11.

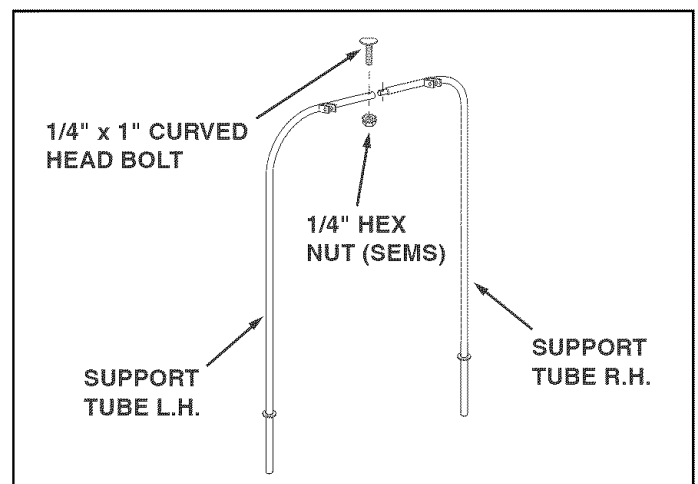

FIGURE 11

- Place the support tubes down into the front and rear tube support brackets, with the tube's welded brackets facing the center of the cart.
- Assemble the top connecting tubes to the support tubes using four 1/4" x 1-1/4" hex bolts and 1/4" nylock nuts. **Tighten** until the end of the bolt extends through the nut. See Figure 12.

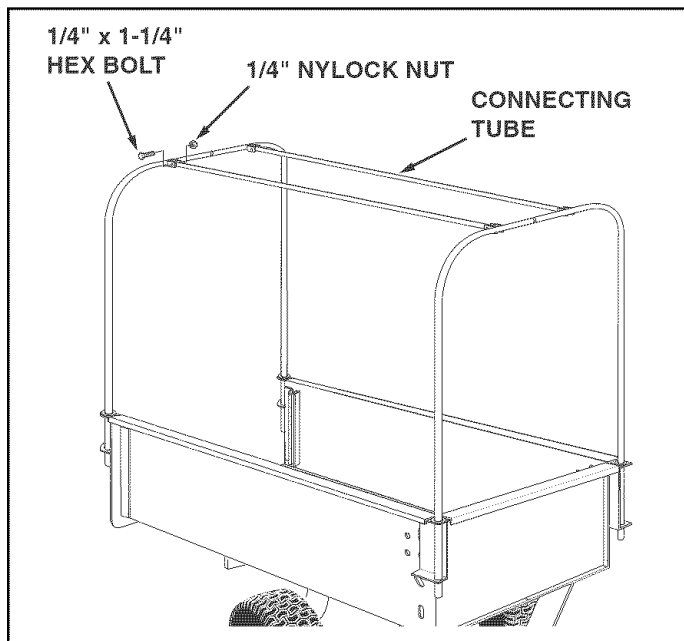

FIGURE 12

- To install the fabric cart cover:
 1. Unzip the cover's rear flap and place cover on top of the support tubes, making sure that the zippered flap is at rear of cart.
 2. Pull the front of the cover down over the front support tubes and hook the cover's plastic channel under the cart's front flange.
 3. Pull the sides of the cover down and hook the cover's plastic channel under the cart's side flanges.
 4. Swing the rear flap up onto the top of the cover. Starting at the top, secure the cover to the rear support tubes with the three velcro straps on each side. Tighten the straps so that the zipper is pulled around behind the support tubes. The zipper should close easily.
 5. Unzip the rear flap to place the tailgate down into the tailgate guides. See Figure 13.

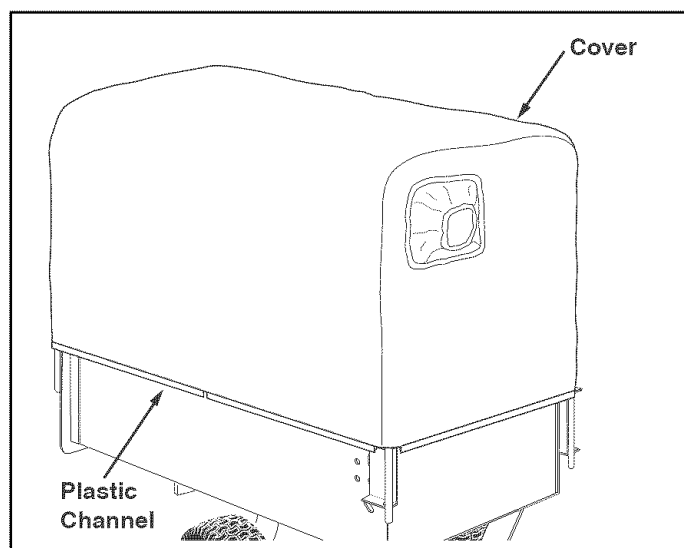

FIGURE 13

- Assemble a plastic wheel to each engine mount bracket using a 3/8" shoulder bolt and 3/8" hex lock nut. See Figure 14.

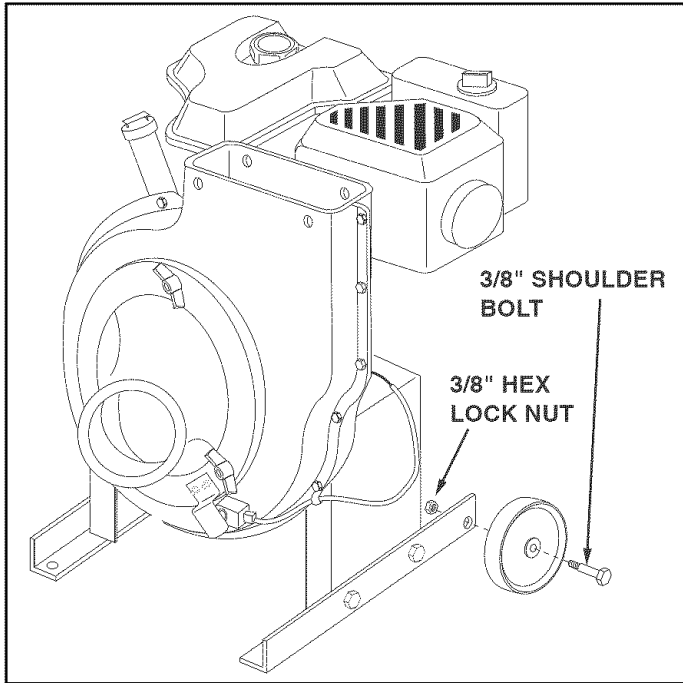

FIGURE 14

- Attach the vac tongue to your tractor's draw bar for easier mounting of the engine base assembly.
- Align the engine base with the tongue's welded angles. Tilt the engine base back on its wheels so that the ends of the mount brackets rest on the tongue, **underneath** the welded angles. Lift up on the engine base and slide the engine mount brackets **underneath** the welded angles. Fasten the mount brackets to the welded angles using four 5/16" x 1" hex bolts and 5/16" nylock nuts. **Tighten** the bolts securely. See figure 15.

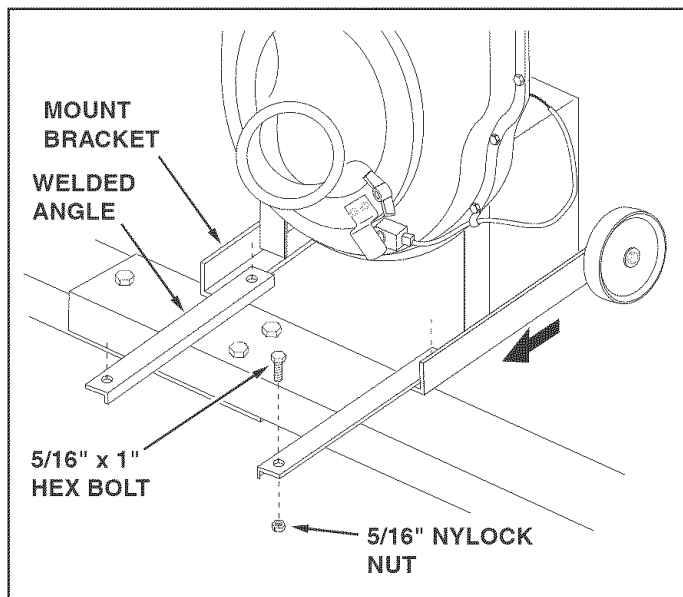

FIGURE 15

- Remove the hex bolts, lock washers and hex lock nuts from the two holes in the impeller housing as shown in figure 16. Assemble the hose hanger bracket to the two holes using the bolts, lock washers and lock nuts which you removed.

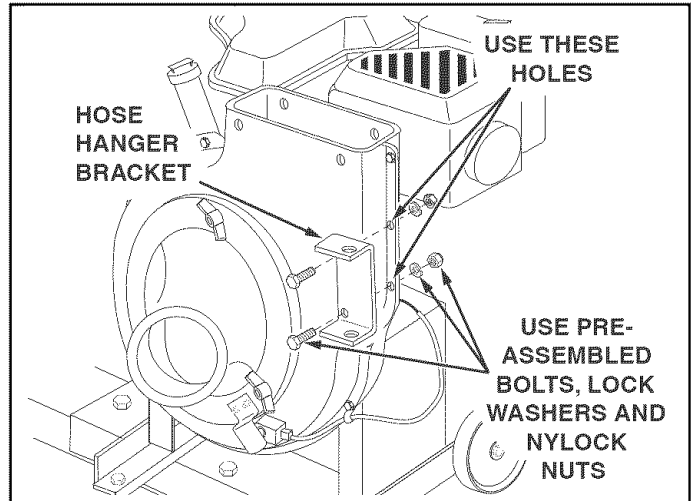

FIGURE 16

- Assemble the elbow to the impeller housing using four 5/16" x 3/4" thread forming bolts and four nylon washers. Push while turning to help start the bolts into the unthreaded holes. **Tighten**. See figure 17.
- If the elbow does not align with the cover opening:
 - Step 1** Loosen the four bolts shown and adjust the position of the engine base. Retighten the bolts.
 - Step 2** Loosen (about 1/4 turn) the four bolts shown. Push against the elbow to center it in the opening. Retighten the bolts.
- Pull the boot onto the end of the elbow and tighten the draw string.

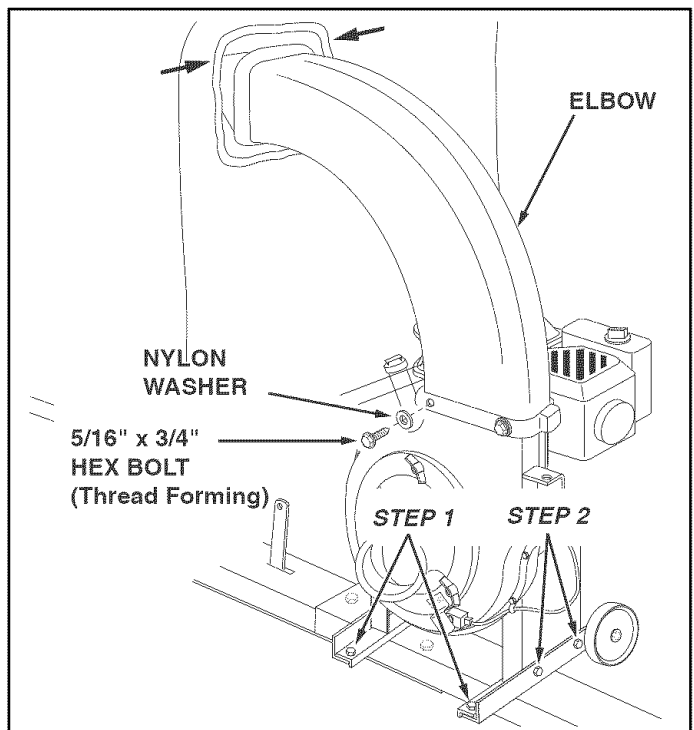

FIGURE 17

- Place the hose hanger rod assembly down into the hose hanger bracket on the impeller housing assembly. See figure 18.

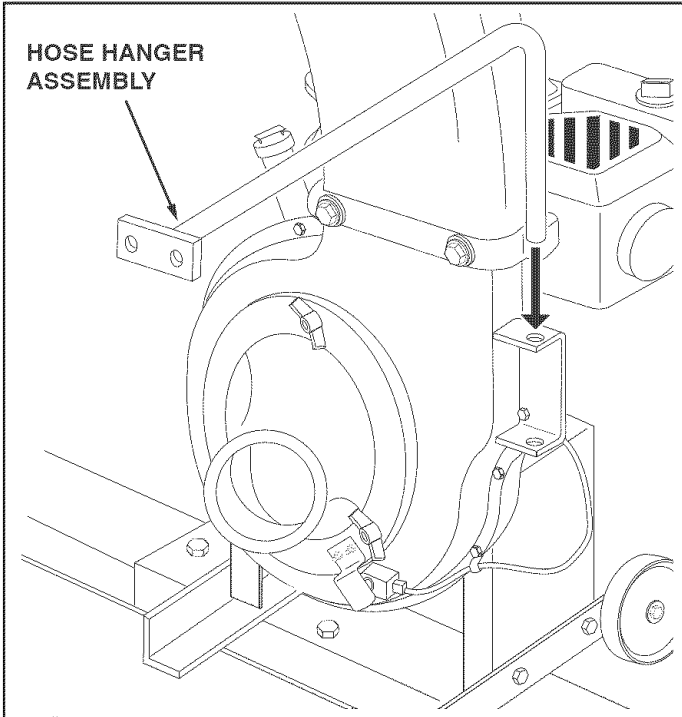

FIGURE 18

- Loop the 25" tarp strap under the hose. Fasten the hooks to the hose hanger rod assembly. See figure 20.

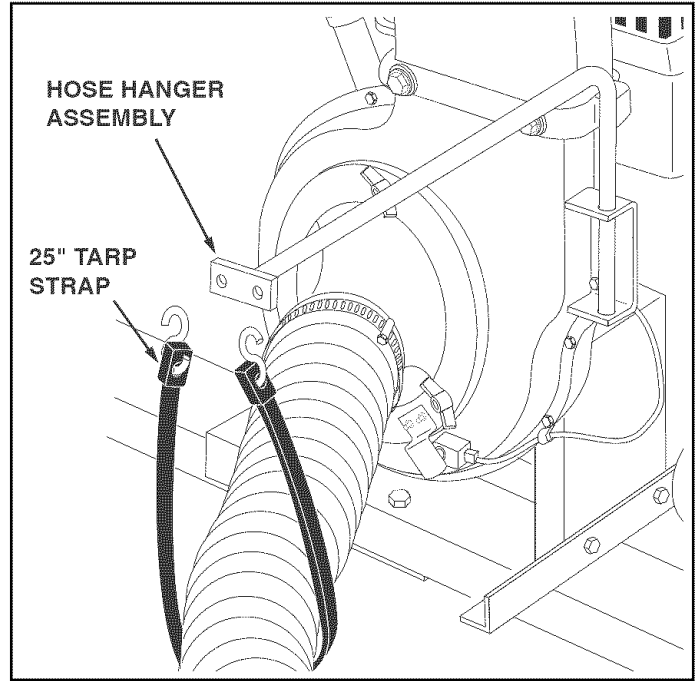

FIGURE 20

- Place a hose clamp onto the end of the hose. Push the hose onto the hose adapter (nozzle). Tighten the hose clamp onto the hose and hose adapter. **Do not collapse the hose adapter when tightening the clamp.** See figure 19.
- The remaining hose clamp will be used later to fasten the hose to the deck adapter.

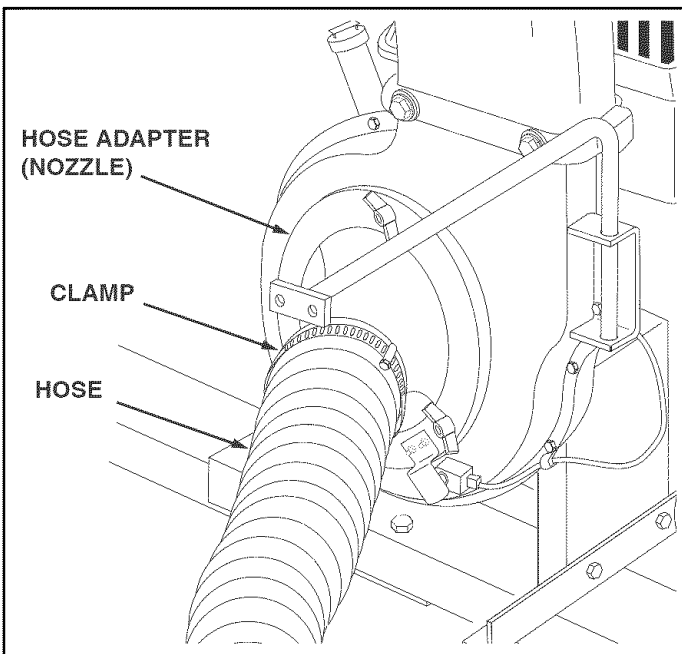

FIGURE 19

- Assemble the hitch plate to the tractor hitch if:
 - Your tractor has a square (straight) hitch frame, to help prevent binding.
 - Your tractor has a lightweight hitch frame that needs reinforcement for towing.
 Use a 1/2" x 1-1/2" hex bolt, a 7/16" flat washer and a 1/2" nylock nut. See figure 21.

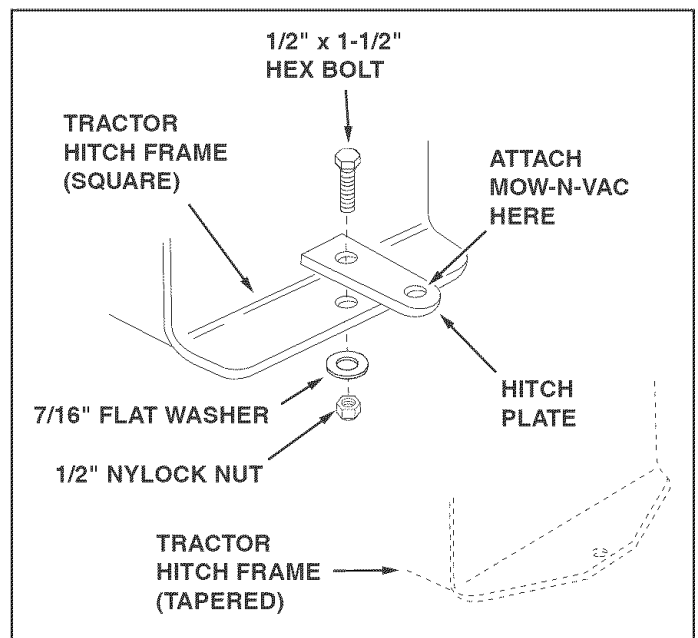

FIGURE 21

ASSEMBLING THE #62468 DECK ADAPTER TO THE MOWER DECK

NOTE: Not all of the parts in the deck adapter hardware package will be used for any one particular fit up.

- Remove the mower discharge deflector from your mower deck. Save the deflector and hardware for remounting deflector.



CAUTION: Mower deflector must be replaced when Vac System deck adapter is removed. Do Not operate mower unless adapter or deflector is in place and properly mounted.

FITTING TO SEARS TRACTORS

The **yellow** fold out sheet contains the templates for Sears tractors only. (The white fold out sheets include all templates, including other tractor brands.)

If you have a Murray brand tractor with a 38", 40" or 46" deck, go directly to the instructions on pages 16 and 17.

- Identify and cut out the template for your **brand and size** mower deck. If there is no template included for your deck size, you can make your own template by marking around a piece of cardboard held against the edge of the deck's discharge opening.
- FOLLOW THE INSTRUCTIONS PRINTED ON THE TEMPLATE.** If there are no instructions, use the following instructions as a general guide.
- Tape the template to the face of the adapter, about 1/2" from front and 1/4" down from top for deeper decks. For shallow decks, position template low enough that adapter will not extend below bottom of deck. Mark outline of template on face of adapter using white crayon, nail or scribe. Drill a starting hole inside the outline, then use a saber saw or key hole saw to cut out the opening. See figure 22.

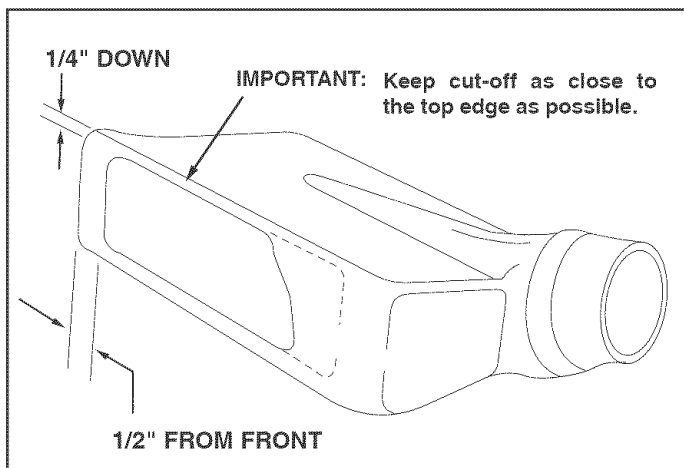

FIGURE 22

- Position the adapter over the deck opening, and check for fit of cutout as shown in figure 23. Trim cutout, if necessary, to allow tilting of adapter, keeping the fit as close as possible for best vacuum suction.

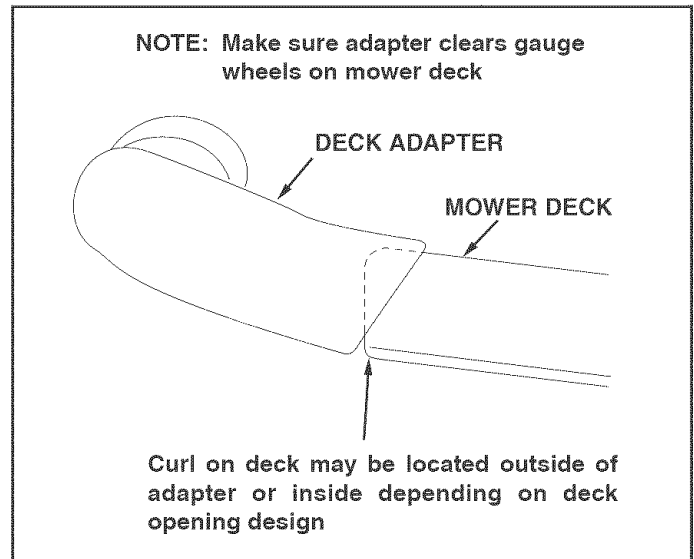

FIGURE 23

- Holding the adapter bracket and the deck adapter together, position the deck adapter on the mower deck. Keeping the edge of deck adapter as close as possible to the offset in the adapter bracket, see if the slot in the adapter bracket can be aligned with one or two of the deflector holes in your mower deck's discharge opening. If the bracket can not be located correctly using existing holes, it will be necessary to drill one or two 5/16" diameter holes in the deck. See figure 24.

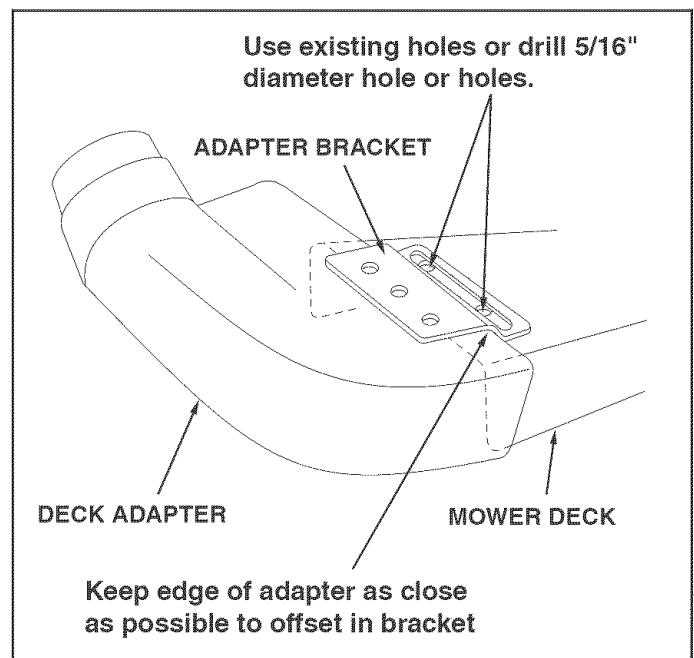

FIGURE 24

- Assemble the adapter bracket to the deck using two 5/16" x 1-1/4" hex bolts, 5/16" flat washers and 5/16" nylock nuts. See figure 25.

NOTE: It may be necessary to use extra 5/16" flat washers to shim under the bracket next to the deck surface. Ten extra washers have been furnished as shims. See figure 25.

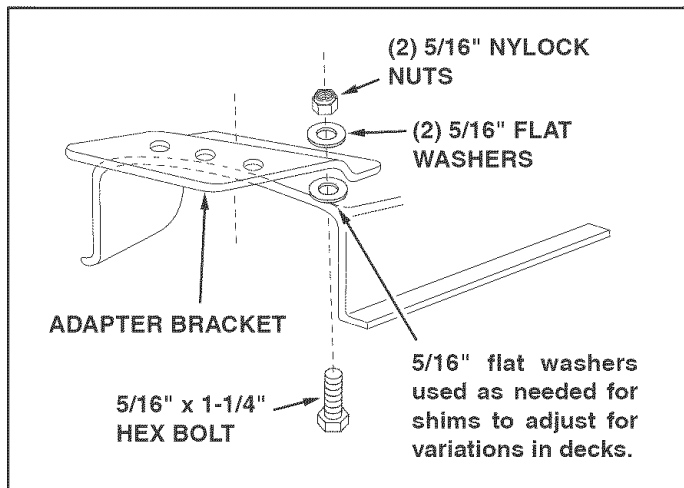

FIGURE 25

- With deck adapter positioned correctly over the discharge opening, use the adapter bracket as a template and drill three 9/32" diameter holes in the top of the deck adapter. See figure 26.
- Bolt deck adapter to bracket using three 1/4" x 1" bolts, nylon washers, 1/4" flat washers and 1/4" nylock nuts. Nylon washers should be against the inside of the deck adapter. See figure 26.

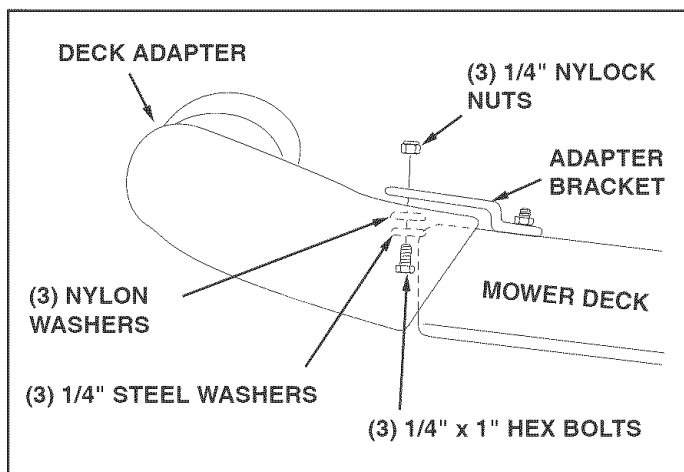

FIGURE 26

- Assemble end of hose and a hose clamp over the round opening of deck adapter and tighten clamp. **GO DIRECTLY TO THE OPERATION INSTRUCTIONS ON PAGE 18.**

FOR 1990 AND NEWER MURRAY TRACTORS WITH A 38" OR 40" DECK

- Cut out two templates and place on deck adapter as shown in figure 33. Tape smaller one on top and larger one on the side and bottom. After they are in place, carefully mark around the templates, then cut out adapter to obtain correct opening.
- Bolt end of mounting strap to the 5/16" bolt on the mower deck. The other end of the strap will bolt to a hole in the deck adapter, which must be drilled. Position the adapter on the deck, then drill a 5/16" hole in the bottom of the adapter that will align with the hole in the strap. Fasten the adapter to the strap using one 1/4" x 1" hex bolt, 1/4" flat washer, nylon washer and 1/4" nylock nut. See figure 27.

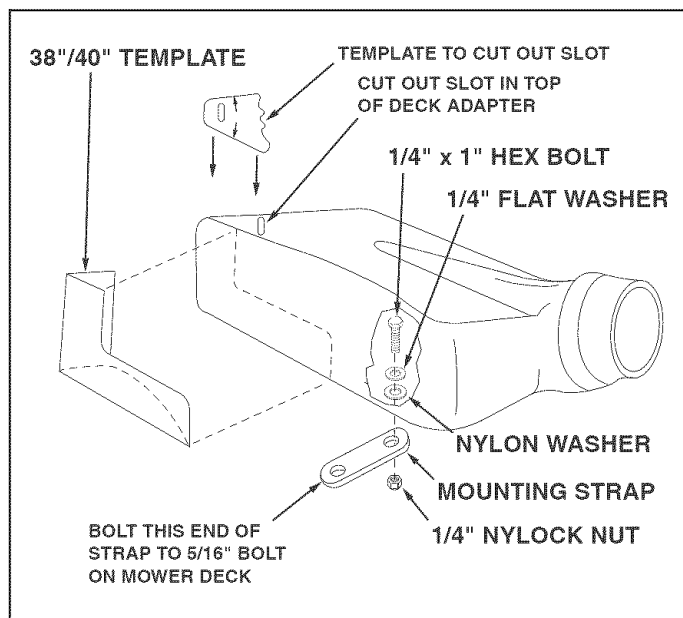

FIGURE 27

- Assemble end of hose and hose clamp over the round opening of deck adapter and tighten clamp. **GO DIRECTLY TO THE OPERATION INSTRUCTIONS WHICH ARE LOCATED ON PAGE 18.**

**FOR 1990 AND NEWER MURRAY TRACTORS
WITH A 46" DECK**

- Tape 46" template onto deck adapter. Mark and then cut out adapter .
- Fasten the angle bracket and the mounting bracket to the mower deck as shown in figure 34. Use two 5/16" x 1" carriage bolts, 5/16" flat washers and 5/16" nylock nuts. The bolt heads go on inside of mower deck.
- Drill two 5/16" diameter holes in the deck adapter that will align with the holes in the angle bracket and the mounting bracket. Assemble the deck adapter to both brackets using two 1/4" x 1" hex bolts, 1/4" flat washers, nylon washers and 1/4" nylock nuts. See figure 28.

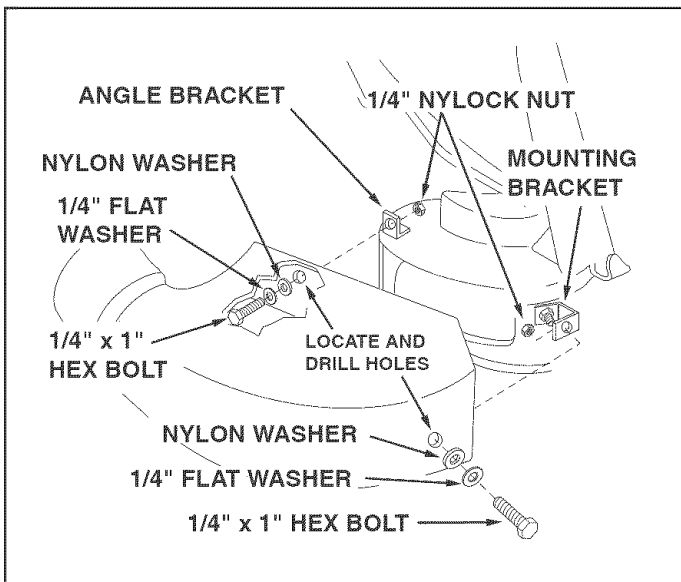

FIGURE 28

- Assemble end of hose and hose clamp over the round opening of deck adapter and tighten clamp.
GO DIRECTLY TO THE OPERATION INSTRUCTIONS WHICH ARE LOCATED ON PAGE 18.

OPERATION

KNOW YOUR VAC SYSTEM

Read this owner's manual and safety rules before operating your Vac System.

Compare the illustration below with your Vac System to familiarize yourself with the various controls and their locations.

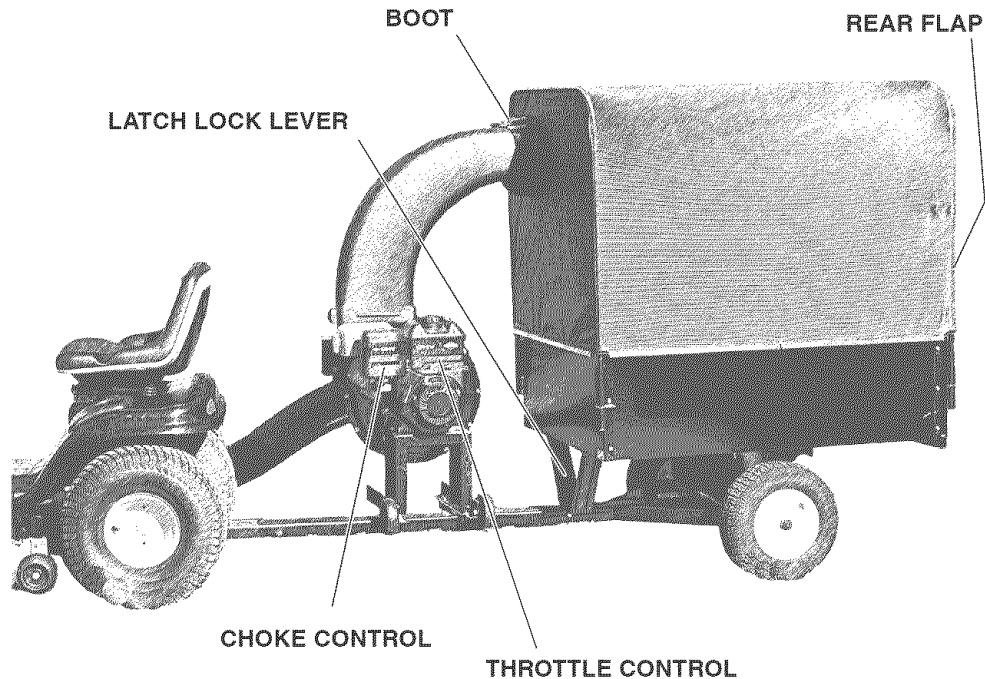

LATCH LOCK LEVER Locks the cart bed down to the tongue. Releases to allow cart to be tipped back for dumping.

BOOT Connects the plastic elbow to the fabric top, directing discharged material into the cart.

REAR FLAP Zippered flap opens to allow contents of cart to be emptied.

THROTTLE CONTROL Controls speed of engine.

CHOKER CONTROL Adjust to allow cold starting.

CAUTION: Alcohol blended fuels (called gasohol or using ethanol or methanol) can attract moisture which leads to separation and formation of acids during storage. Acidic gas can damage the fuel system of an engine while in storage.

To avoid engine problems, the fuel system should be emptied before storage for 30 days or longer. Drain the gas tank, start the engine and let it run until the fuel lines and carburetor are empty. Use fresh fuel next season. See STORAGE Instructions for additional information.

Never use engine or carburetor cleaner products in the fuel tank or permanent damage may occur.

BEFORE STARTING

- Your Vac System engine is shipped without oil or gasoline. Service the engine with oil and gas as instructed in the separate engine manual.
- Inspect the Vac System to make sure all covers (rear door, vinyl boot, elbow, hose adapter, hose and deck adapter) are properly attached.
- Check tires for proper inflation (12 - 14 lbs).

HOW TO STOP YOUR VAC SYSTEM

- To stop engine, move the throttle control lever to the OFF position.
- Disconnect spark plug wire from plug to prevent accidental starting while equipment is unattended or is being worked on.



WARNING: Never fill fuel tank indoors, or with the engine running, or while the engine is hot. Do not smoke while filling tank.



CAUTION: The muffler and adjacent areas are hot!

HOW TO START YOUR VAC SYSTEM



WARNING: Never start or run the engine without all covers being properly attached to the blower housing and cart.

- Check oil and gas in Vac engine.
- Attach spark plug wire to spark plug.
- Move choke lever on engine to CHOKE position. (A warm engine may not require choking.)
- Move throttle control lever on engine to FAST position.
- Grasp starter handle and pull rope out slowly until engine reaches start of compression cycle (rope will pull slightly harder at this point). Let the rope rewind slowly.
- Pull rope with a rapid, continuous, full arm stroke. Keep a firm grip on starter handle. Let rope rewind slowly. Do not let starter handle snap back against starter.
- Repeat instructions in two preceding paragraphs until engine fires. When engine starts, move choke control gradually to RUN position.

HOW TO USE YOUR VAC SYSTEM



CAUTION: Vehicle braking and stability may be affected with the addition of an accessory or an attachment. Be aware of changing conditions on slopes.

- Inspect the Vac to make sure the cover, rear door, boot, elbow, hose adapter (nozzle), hose and deck adapter are properly attached.
- Check tires for proper inflation (12 - 14 lbs).
- Check for oil and gas in Vac engine.
- Begin operation at low speed, adjusting forward speed to match grass height and/or moisture condition to prevent clogging.
- Do not attempt to vacuum up any material other than vegetation found in a normal yard, such as light branches, leaves, twigs, etc.



WARNING: Should your Vac System become clogged, shut off tractor and Vac engines. Before attempting to unclog, remove wire from spark plug to prevent accidental starting.

TO EMPTY THE CART

- Shut off the tractor engine and set the brake.
- Shut off the Vac engine.
- Loosen the draw string and pull the boot back from the elbow.
- Unzip the rear flap, flip it up and secure it with the velcro strips on top of the cover.



CAUTION: To avoid possible injury, be sure that no one is near the cart before releasing the latch lock lever.

- Remove the tailgate.
- Release the latch lock lever on the tongue and tip the cart back.
- Using a rake or suitable tool, pull grass clippings and/or leaves out of the cart.
- After the cart is emptied, tip it forward and secure it to the tongue with the latch lock lever. Install the tailgate, place the bottom of the rear flap inside the tailgate and zip the rear flap shut.

TO USE THE CART WITHOUT THE VAC SYSTEM

- Unzip the rear flap and unfasten the velcro fasteners.
- Remove and store the soft top cover.
- Remove the tube frame in one piece and store.



CAUTION: The muffler and adjacent areas are hot!

- Remove and store the four bolts and nuts which fasten the engine base to the tongue.
- Slide the engine off the tongue and roll to a safe storage area.

MAINTENANCE

CUSTOMER RESPONSIBILITIES

- Read and follow the maintenance schedule and the maintenance procedures listed in this section.

MAINTENANCE SCHEDULE Fill in dates as you complete regular service.	Service Dates											
	Before each use	After each use	Every season	Before storage								
Check for loose fasteners	X											
Check cover	X											
Check tire pressure	X											
Check engine oil level	X											
Lubricate			X									
Clean		X		X								

Maintain engine per instructions below and in engine manual.

BEFORE EACH USE

CHECK FOR LOOSE FASTENERS

- Make a thorough visual check of the Vac System for any bolts and nuts which may have loosened. Retighten any loose bolts and nuts.

CHECK COVER

- Check the cover, especially the front boot and the rear flap for wear. Replace cover if worn or damaged.

CHECK TIRE PRESSURE

- Check tire pressure regularly. Recommended tire pressure is 12-14 Lbs.

CHECK ENGINE OIL LEVEL

- Check oil level before each use. Maintain engine oil as instructed in the separate engine manual.

LUBRICATION

- At the beginning of each season, lubricate the latch, latch pivot bolt, and the axle where the hitch tongue pivots, with a light machine oil.
- At least once a season, grease or oil the wheel bearings. Use automotive wheel bearing type grease or 20 weight oil.



WARNING: Always stop engine and disconnect spark plug wire before cleaning, lubricating or before performing any repairs or maintenance.

ENGINE MAINTENANCE

Only use high quality detergent oil rated with API service classification SF or SG. Select the oil's SAE viscosity grade according to your expected operating temperature. SAE 30 grade oil is recommended for warm weather use. For cold weather use refer to the engine manufacturer's Operating and Maintenance Manual.

- Check **oil level** before each use. Maintain engine oil as instructed in the separate engine manual.
- Service **air cleaner** every 25 hours under normal conditions. Clean every few hours under extremely dusty conditions. Poor engine performance and flooding usually indicates that the air cleaner should be serviced. To service the air cleaner, refer to the separate engine manual.
- The **spark plug** should be cleaned and the gap reset once a season. Spark plug replacement at the start of each season is recommended. Check the engine manual for correct plug type and gap specifications.

CLEANING

- Make sure the cart and top are cleaned after each use. Grass clippings and leaves left in the cart will mildew and cause damage if not cleaned out.
- **Clean the engine** regularly with a cloth or brush. Keep the cooling fins on the engine housing clean to permit proper air circulation which is essential to engine performance and life. Be sure to remove all dirt and debris from muffler area.

STORAGE

- Clean the engine and the entire unit thoroughly.
- Refer to engine manual for correct engine storage instructions.
- If storing in an unventilated or metal storage shed, coat metal parts with light oil or silicone to prevent rust.
- Store unit in a clean, dry area.

It is important to prevent gum deposits from forming in essential fuel system parts such as the carburetor, fuel filter, fuel hose or tank during storage. Also, alcohol blended fuels (called gasohol or using ethanol or methanol) can attract moisture which leads to separation and formation of acids during storage. Acidic gas can damage the fuel system of an engine while in storage.

To avoid engine problems, the fuel system should be emptied before storage of 30 days or longer. Follow the instructions in the engine's Operating & Maintenance Manual.

TROUBLESHOOTING

PROBLEM	POSSIBLE CAUSE(S)	CORRECTIVE ACTION
Engine fails to start	<ol style="list-style-type: none"> 1. Spark plug wire disconnected. 2. Safety switch not contacted. 3. Fuel tank empty, or stale fuel. 4. Fuel shut-off valve closed (if so equipped). 5. Faulty spark plug. 	<ol style="list-style-type: none"> 1. Connect wire to spark plug. 2. Correctly install hose adapter nozzle. 3. Fill tank with clean, fresh fuel. 4. Open fuel shut-off valve. 5. Clean, adjust gap or replace.
Loss of power; operation erratic.	<ol style="list-style-type: none"> 1. Spark plug wire loose 2. Unit running on CHOKE. 3. Blocked fuel line or stale fuel. 4. Water or dirt in fuel system. 5. Carburetor out of adjustment. 6. Dirty air cleaner. 	<ol style="list-style-type: none"> 1. Connect and tighten spark plug wire. 2. Move choke lever to OFF position. 3. Clean fuel line; fill tank with clean fresh gasoline. 4. Disconnect fuel line at carburetor to drain fuel tank. Refill with fresh fuel. 5. Adjust carburetor.* 6. Service air cleaner.*
Engine overheats	<ol style="list-style-type: none"> 1. Carburetor not adjusted properly. 2. Engine oil level low. 	<ol style="list-style-type: none"> 1. Adjust carburetor.* 2. Fill crankcase with proper oil.
Too much vibration	Loose parts or damaged impeller.	Stop engine immediately and disconnect spark plug wire. Tighten all bolts and nuts. Make all necessary repairs. If vibration continues, have unit serviced by an authorized service dealer.
Unit does not discharge	<ol style="list-style-type: none"> 1. Discharge chute (elbow) clogged. 2. Foreign object lodged in impeller. 3. Vac Cart is full. 	<ol style="list-style-type: none"> 1. Stop engine immediately and disconnect spark plug wire. Clean inside of housing and discharge chute (elbow). 2. Stop engine immediately and disconnect spark plug wire. Remove lodged object. 3. Empty cart.

*Refer to the engine manual packed with your unit.

NOTE: For repairs beyond the minor adjustments listed above, please contact your nearest authorized service dealer.

NOTES

PARTS

REPAIR PARTS FOR MODEL 486.245041 SOFT TOP MOW-N-VAC CART

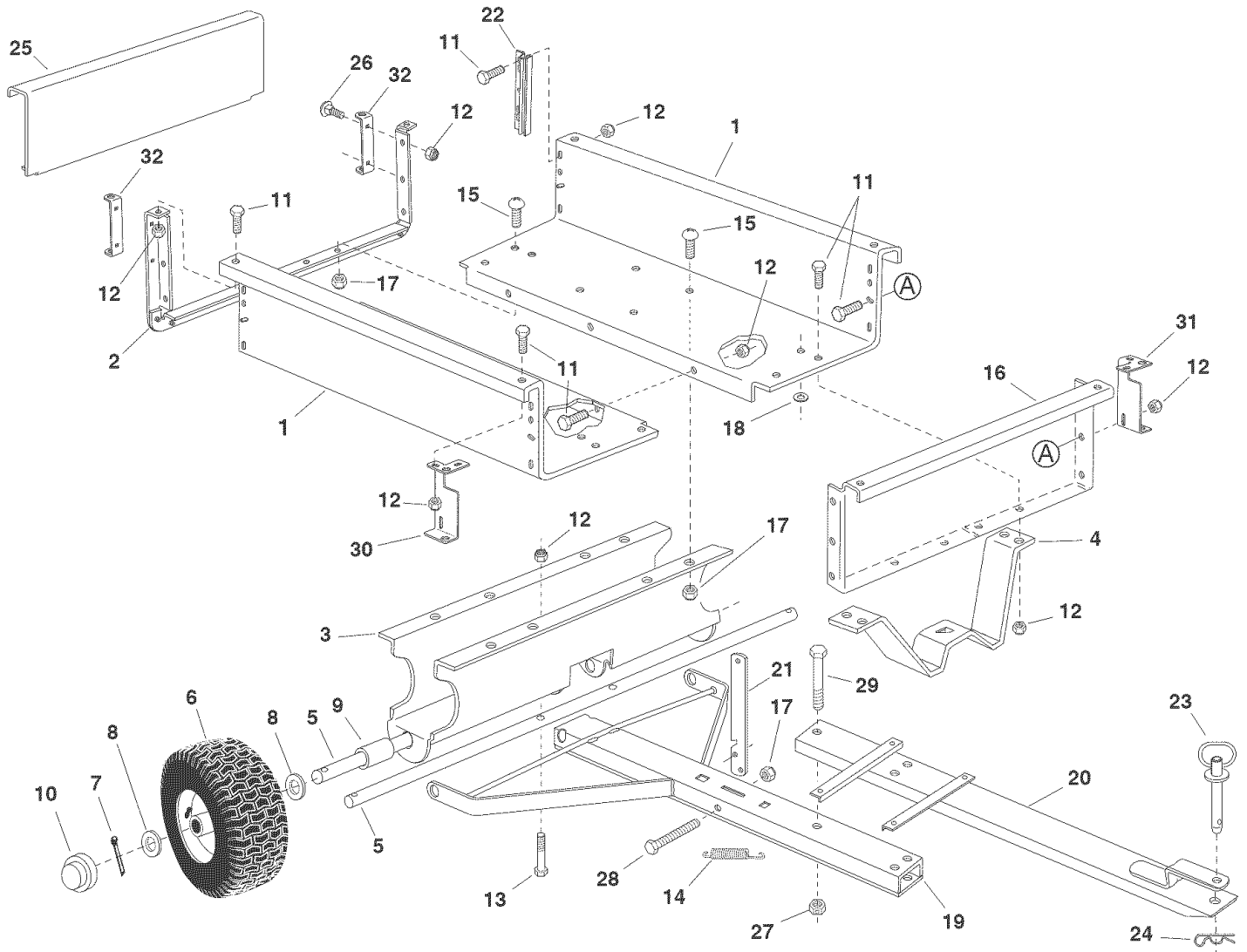

REF. NO.	PART NO.	QTY.	DESCRIPTION	REF. NO.	PART NO.	QTY.	DESCRIPTION
1	24096	2	Cart Body	17	47810	13	Hex Nut, 5/16-18 Nylock
2	62457	1	Tailgate Reinforcement Bracket	18	43088	2	Washer, Flat 1/4"
3	23487	1	Wheel Support	19	64551	1	Tongue Weldment Ass'y. (Rear)
4	24497	1	Latch Stand Bracket	20	64531	1	Tongue Weldment Ass'y. (Front)
5	24984	1	Axle, Wheel 1" Dia.	21	25010	1	Latch Lock Lever
6	43594	2	Wheel w/Tire	22	23548	2	Tailgate Guide
7	43093	2	Cotter Pin, 1/8" Dia. x 1-1/2"	23	43884	1	Hitch Pin
8	43601	4	Washer, Flat 1"	24	43343	1	Pin, Hair Cotter 1/8"
9	48637	2	Spacer Tube	25	23504	1	Tailgate
10	43014	2	Hub Cap	26	44950	4	Carriage Bolt, 1/4-20 x 3/4"
11	43012	25	Hex Bolt, 1/4-20 x 3/4"	27	43082	3	Hex Lock Nut, 3/8-16 Thread
12	47189	31	Hex Nut, 1/4" Nylock	28	47407	1	Hex Bolt, 5/16-18 x 4"
13	1509-69	2	Hex Bolt, 1/4-20 x 1-3/4"	29	43574	3	Hex Bolt, 3/8-16 x 3"
14	HA20186	1	Spring, Extension	30	24960	1	Tube Support Bracket, Front R.H.
15	43814	12	Truss Hd. Bolt, 5/16-18 x 3/4"	31	24959	1	Tube Support Bracket, Front L.H.
16	23490	1	Cart Front Panel	32	25539	2	Tube Support Bracket, Rear

REPAIR PARTS FOR MODEL 486.245041 SOFT TOP MOW-N-VAC

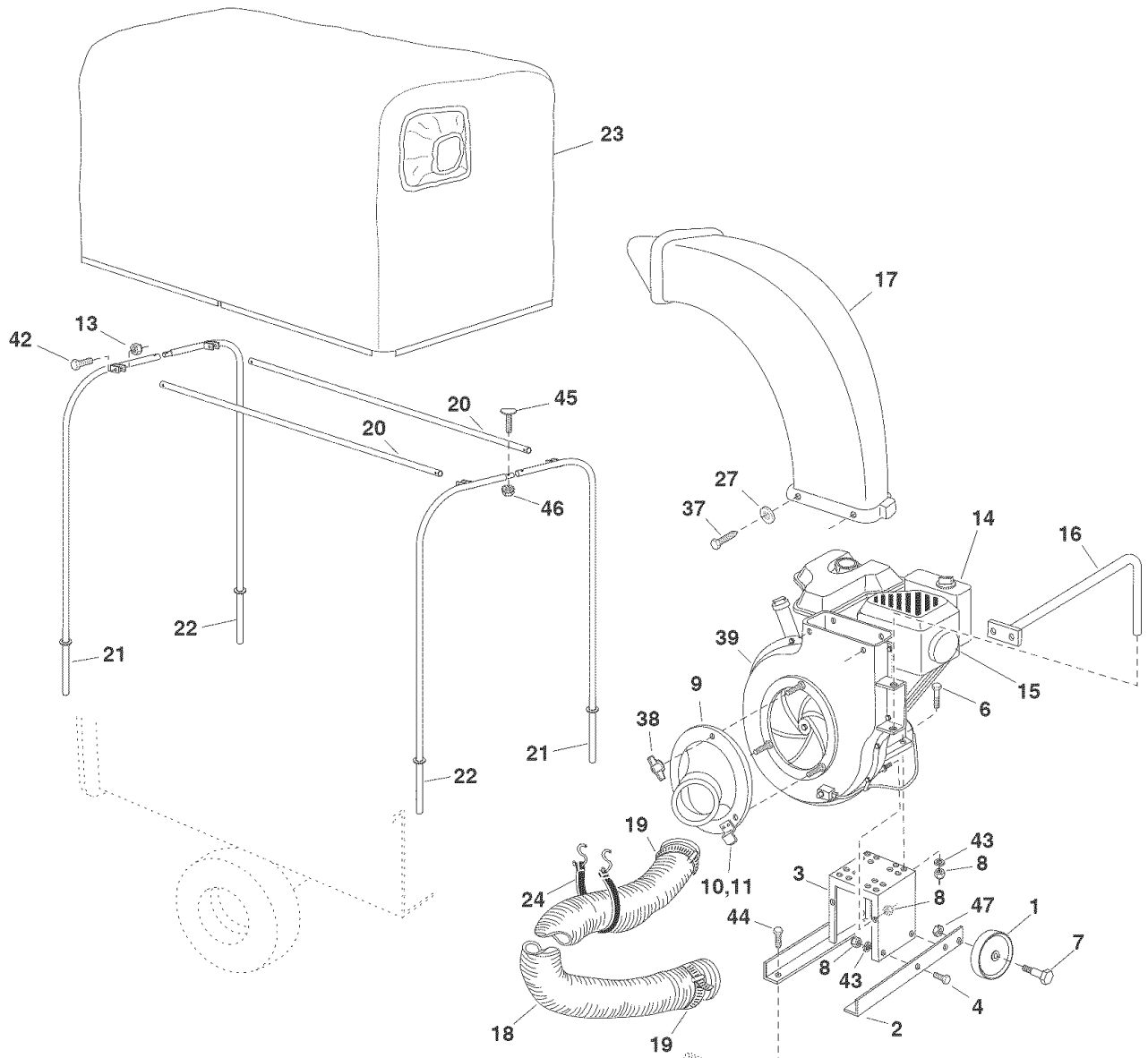

ADAPTER #62468

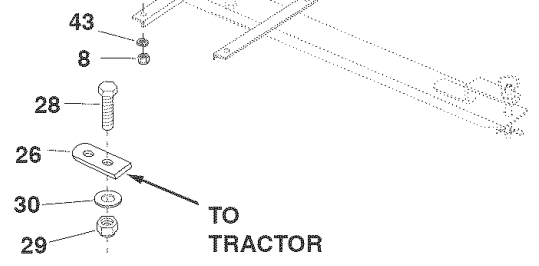
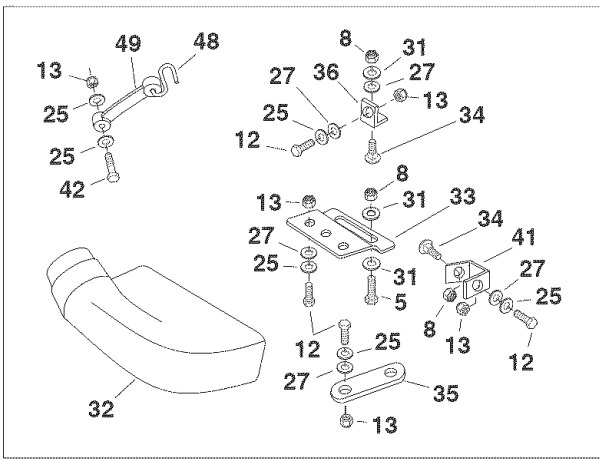

REPAIR PARTS FOR MODEL 486.245041 SOFT TOP MOW-N-VAC

REF. NO.	PART NO.	QTY.	DESCRIPTION	REF. NO.	PART NO.	QTY.	DESCRIPTION
1	734-0973	2	Engine Wheel	33	23560	1	Bracket, Deck Adapter
2	24957	2	Engine Mount Bracket	34	44326	2	Bolt, Carr. 5/16" x 1"
3	24956	1	Engine Base	35	23825	1	Mounting Strap
4	43182	4	Bolt, Hex 5/16-18 x 3/4"	36	23826	1	Angle Bracket
5	43840	2	Bolt, Hex 5/16-18 x 1-1/4"	37	47630	4	Screw, Self Tap 5/16"-18 x 3/4"
6	43085	4	Bolt, Hex 5/16-18 x 1-1/2"	38	712-0421	3	Knob (See also Item #8, Page 22)
7	738-0373	2	Shoulder Bolt	39		1	Impeller Housing Assembly
8	47810	17	Nut, Hex 5/16-18 Nylock				(See Page 22)
9	63375	1	Assembly, Hose Adapter (Nozzle) <i>(Includes items 10 and 11)</i>	40	62468	1	Deck Adapter Kit (Includes parts in box shown on page 20)
10	781-0635	1	Bracket, Switch (Actuator)	41	23827	1	Mounting Bracket
11	728-3001	3	Rivet, Pop 5/32"	42	1509-90	6	Bolt 1/4-20 x 1-1/4"
12	43661	4	Bolt, Hex 1/4-20 x 1"	43	43086	8	Lock Washer, 5/16"
13	47189	7	Nut, Hex 1/4-20 Nylock	44	43063	4	Bolt, Hex 5/16-18 x 1"
14	1273120113-E1	1	Engine, B & S 5.5 HP	45	43978	2	Bolt, Curved Hd. 1/4-20 x 1"
15	222261	1	Deflector, Muffler	46	46978	2	Nut, Hex 1/4-20 SEMS
16	63227	1	Hose Hanger Rod Ass'y.	47	43082	2	Nut, Hex Lock 3/8-16
17	46420	1	Elbow	48	44849	2	"S" Hook
18	43792	1	Hose (6" x 84")	49	44850	2	Tarp Strap
19	43793	2	Hose Clamp 6"		49636	1	Owner's Manual
20	48634	2	Top Connecting Tube				
21	64647	2	Support Tube, L.H.				
22	64648	2	Support Tube, R.H.				
23	48640	1	Cart Cover				
24	43790	1	Strap, Tarp 25"				
25	43088	4	Washer, 1/4" STD				
26	23540	1	Hitch Plate				
27	1543-69	9	Washer, Nylon 21/64"				
28	43020	1	Bolt, Hex 1/2-13 x 1-1/2"				
29	712-3083	1	Nut, Hex 1/2-13 Nylock				
30	43352	1	Washer, Flat 7/16"				
31	43081	12	Washer, 5/16" STD				
32	43830	1	Adapter, Deck				

REPAIR PARTS FOR MODEL 486.245041 SOFT TOP MOW-N-VAC IMPELLER HOUSING ASSEMBLY

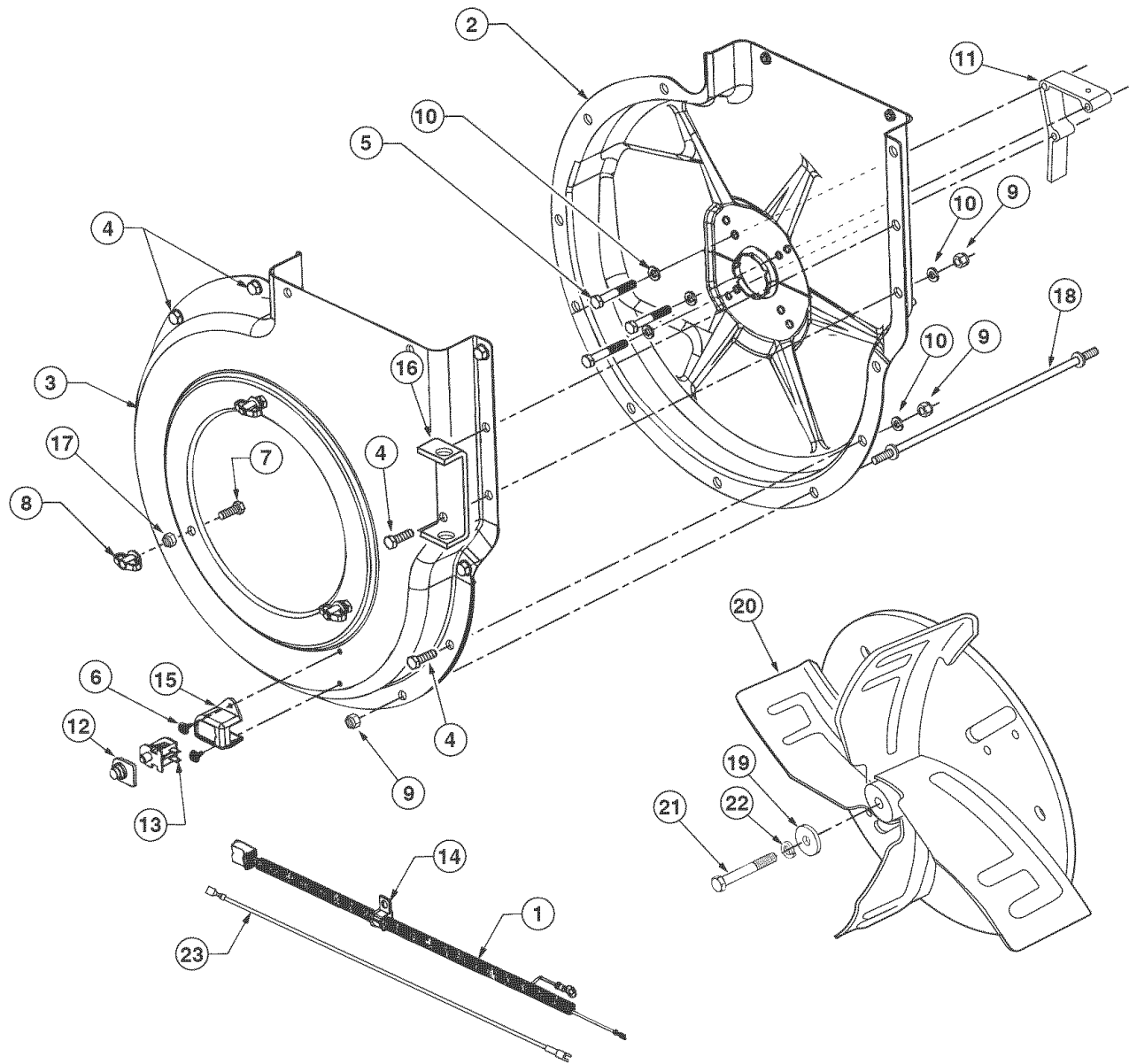

REF. NO.	PART NO.	QTY.	DESCRIPTION	REF. NO.	PART NO.	QTY.	DESCRIPTION
1	629-0241A	1	Harness, Wire	13	725-3166	1	Snap Mount Switch
2	24634	1	Housing Ass'y. Inner	14	726-0272	1	Clamp
3	24633	1	Housing Ass'y. Outer	15	731-1613	1	Cover, Switch
4	43182	10	Bolt, Hex 5/16-18 x 3/4"	16	24958	1	Hose Hanger Bracket
5	710-0772	3	Bolt, Hex 5/16-24 x 2"	17	48848	3	Nut, Nylock Jam 5/16-18
6	710-1268	2	Screw, Self Tap #10-16 x 3/8"	18	48591	2	Spacer Rod
7	43063	3	Bolt, Hex 5/16-18 x 1"	19	736-0247	1	Flat Washer, 13/32" x 1-1/4"
8	712-0421	3	Knob	20	63924	1	Impeller Assembly
9	47810	12	Nut, Nylock 5/16-18	21	710-1273	1	Bolt, Hex 3/8-24 x 2-3/4"
10	43086	13	Washer, Lock 5/16" Spring Type	22	43003	1	Lockwasher, 3/8"
11	719-0330A	1	Adapter, Mounting	23	629-0923	1	Harness Adapter
12	725-1700	1	Cover, Switch				

SLOPE GUIDE

(Keep this sheet in a safe place for future reference.)

Use this guide to determine if a slope is safe for the operation of your tractor and Vac System. Refer also to the instructions in your vehicle owners manual.

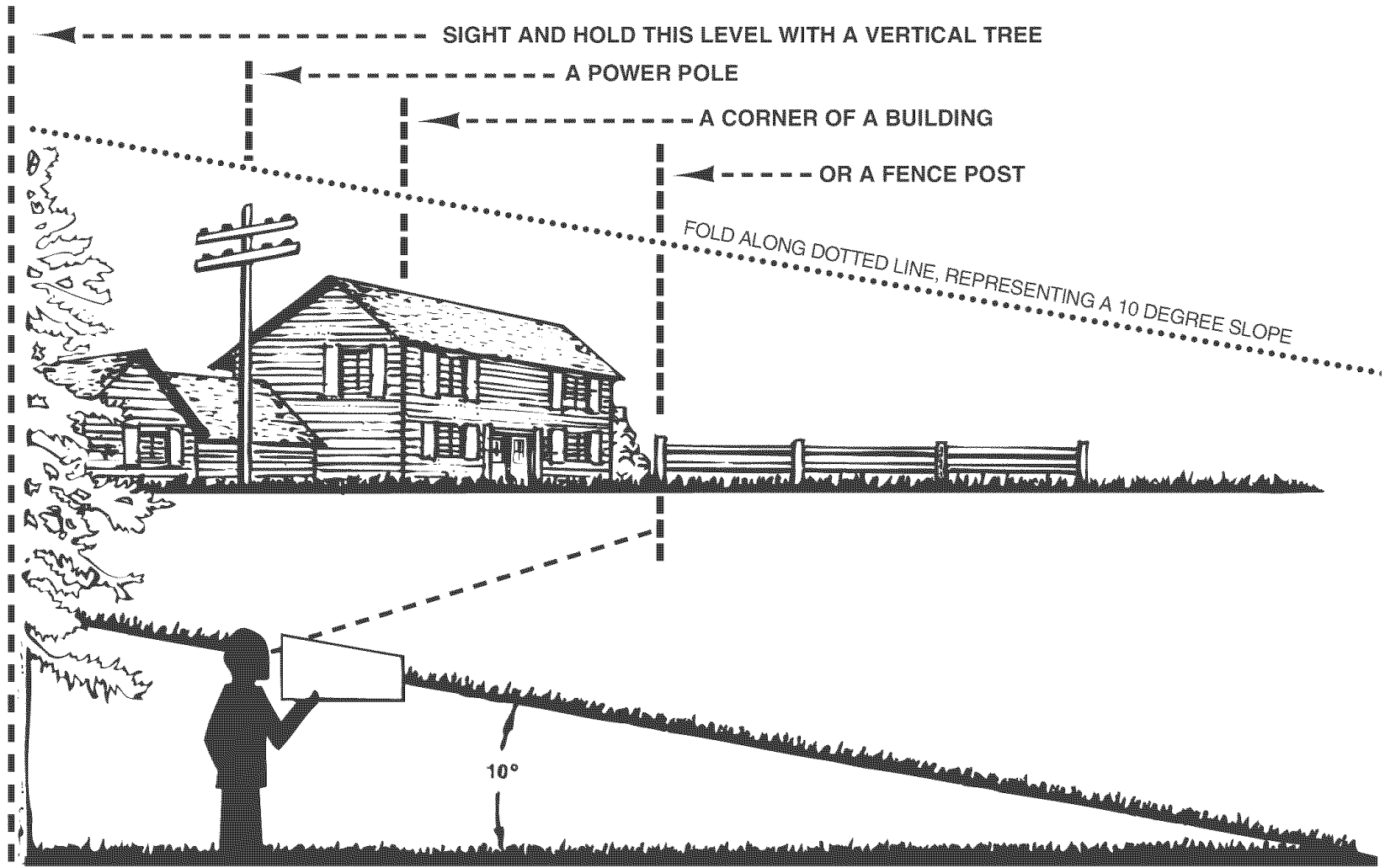

CAUTION: Do not operate your tractor and Vac System on a slope in excess of 10 degrees. Be sure of your tractor's towing and braking capabilities before operating on a slope. Avoid any sudden turns or maneuvers while on a slope.

Get it fixed, at your home or ours!

For repair of major brand appliances **in your own home...**
no matter who made it, no matter who sold it!

1-800-4-MY-HOMESM Anytime, day or night
(1-800-469-4663)

www.sears.com

To bring in products such as vacuums, lawn equipment and electronics
for repair, call for the location of your nearest **Sears Parts & Repair Center.**

1-800-488-1222 Anytime, day or night

www.sears.com

For the replacement parts, accessories and owner's manuals
that you need to do-it-yourself, call **Sears PartsDirectSM!**

1-800-366-PART 6 a.m. – 11 p.m. CST,
(1-800-366-7278) 7 days a week

www.sears.com/partsdirect

To purchase or inquire about a Sears Service Agreement:

1-800-827-6655

7 a.m. – 5 p.m. CST, Mon. – Sat.

Para pedir servicio de reparación a domicilio,
y para ordenar piezas con entrega a domicilio:

1-888-SU-HOGARSM
(1-888-784-6427)

Au Canada pour service en français:

1-877-LE-FOYERSM
(1-877-533-6937)

