

# Owner's Manual

# CRAFTSMAN®

## 42-inch Universal Tow Behind POWER MOWER

Model No. 486.243293

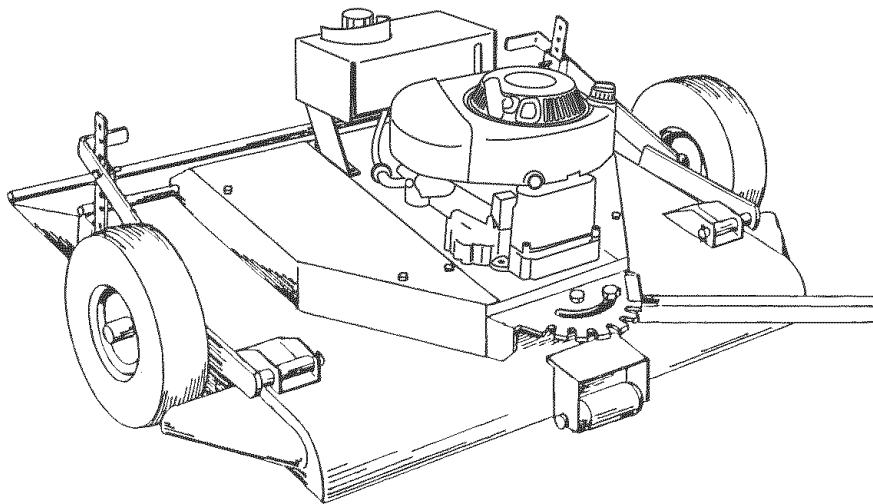

### **CAUTION:**

Before using this product, read this manual and follow all Safety Rules and Operating Instructions.

- Safety
- Assembly
- Operation
- Maintenance
- Parts

### **IMPORTANT - READ THIS FIRST!!!**

For Missing Parts or Assembly Questions  
Please Call 866-576-8388  
Mon.-Fri. 7 am - 5 pm CST.  
FAX 217-728-2032 or e-mail [info@agri-fab.com](mailto:info@agri-fab.com)  
Missing parts will be sent UPS in 24 hours directly to your home.

Sears, Roebuck and Co., Hoffman Estates, IL 60179 U.S.A.  
[www.sears.com/craftsman](http://www.sears.com/craftsman)

## TABLE OF CONTENTS

WARRANTY .....	2	MAINTENANCE .....	14-15
SAFETY RULES.....	3-4	SERVICE AND ADJUSTMENT .....	16-17
CARTON CONTENTS.....	5	STORAGE .....	18
ASSEMBLY.....	6-8	REPAIR PARTS LISTS .....	20-22
WIRING DIAGRAM .....	8	SLOPE GUIDE .....	23
OPERATION.....	9-13	PARTS ORDERING/SERVICE .....	Rear Cover

### LIMITED WARRANTY ON CRAFTSMAN POWERED TRACTOR ATTACHMENTS

For one (1) year from the date of purchase, if this Craftsman Equipment is maintained, lubricated and tuned up according to the instructions in the owner's manual, Sears will repair or replace free of charge any parts found to be defective in material or workmanship. Warranty service is available free of charge by returning your Craftsman equipment to your nearest Sears Service Center. In-home warranty service is available but a trip charge will apply. This Warranty applies only while this product is in the United States.

#### This Warranty does not cover:

- Expendable items which become worn during normal use, such as spark plugs, air cleaners, belts, and oil filters.
- Tire replacement or repair caused by punctures from outside objects, such as nails, thorns, stumps, or glass.
- Repairs necessary because of operator abuse, including but not limited to, damage caused by impacting objects that bend the frame or crankshaft, or over-speeding the engine.
- Repairs necessary because of operator negligence, including but not limited to, electrical and mechanical damage caused by improper storage, failure to use the proper grade and amount of engine oil, or failure to maintain the equipment according to the instructions contained in the owner's manual.
- Engine (fuel system) cleaning or repairs caused by fuel determined to be contaminated or oxidized (stale). In general, fuel should be used **within 30 days** of its purchase date.
- Equipment used for commercial or rental purposes.

### LIMITED WARRANTY ON BATTERY

For ninety (90) days from date of purchase, if any battery included with the equipment proves defective in material or workmanship and our testing determines the battery will not hold a charge, Sears will replace the battery at no charge. Warranty service is available free of charge by returning your Craftsman equipment to your nearest Sears Service Center. In-home warranty service is available but a trip charge will apply. This Warranty applies only while this product is in the United States.

TO LOCATE THE NEAREST SEARS SERVICE CENTER OR TO SCHEDULE SERVICE,  
SIMPLY CONTACT SEARS AT 1-800-4-MY-HOME.

This warranty gives you specific legal rights, and you may also have other rights, which vary from state to state.

# SAFETY RULES

## Safe Operation Practices for Tow Behind Mowers



**WARNING:** This cutting machine is capable of amputating hands and feet and throwing objects. Failure to observe the following safety instructions could result in serious injury or death.

### I. GENERAL OPERATION

- Read, understand and follow all instructions in the manual and on the machine before starting.
- Read this operator's manual carefully. Become familiar with the controls and know how to operate your mower properly.
- Only allow responsible adults who are familiar with the instructions to operate the machine.
- Clear the area of objects such as rocks, toys, wire, etc., which could be picked up and thrown by the blade.
- Be sure the area is clear of other people before mowing. Stop machine if anyone enters the area.
- Never carry passengers.
- Do not mow in reverse unless absolutely necessary. Always look down and behind before and during backing.
- Be aware of the mower discharge direction and do not point it at anyone. Do not operate the mower without the guard in place.
- Slow down before turning.
- Never leave a running machine unattended. Always turn off blades and stop engine.
- Turn off blades when not mowing.
- Mow only in daylight or good artificial light.
- Do not operate the machine while under the influence of alcohol or drugs.
- Watch for traffic when crossing or operating near roadways.
- Use extra care when loading or unloading the machine into a trailer or truck.
- Do not attempt to operate your tractor or mower when not in drivers seat.
- Disengage power to mower and stop engine when transporting or when not in use.
- Exercise special care when mowing around fixed objects in order to prevent the blades from striking them. Never deliberately run tractor or mower onto or over any foreign object.
- Use mower only as the manufacturer intended and as described in this manual.
- Do not operate mower if it has been dropped or damaged in any manner. Always have damage repaired before using your mower.
- Always wear safety glasses or eye shields when starting and while using your mower.
- Dress properly. Do not operate mower when barefoot or wearing open sandals. Wear only solid shoes with good traction when mowing.
- Always make cutting height adjustments before starting your mower. Never attempt to do this while the engine is running.

- Keep your eyes and mind on your mower and the area being cut. Do not let other interests distract you.
- Do not put hands or feet near or under rotating parts. Keep clear of the discharge opening at all times.
- Before cleaning, inspecting, or repairing your mower, stop the engine and make absolutely sure the blade and all moving parts have stopped. Then disconnect the spark plug wire and keep it away from the spark plug to prevent accidental starting.
- Do not operate your mower if it vibrates abnormally. Excessive vibration is an indication of damage; stop the engine, safely check for the cause of vibration and repair as required.
- Never operate your mower without proper guards, plates or other safety devices in place.

### II. SLOPE OPERATION

Slopes are a major factor related to loss-of-control and tip-over accidents, which can result in severe injury or death. All slopes require extra caution. If you feel uneasy on it, do not mow it.

#### DO:

- Mow up and down slopes, not across.
- Remove obstacles such as rocks, tree limbs, etc. Watch for holes, ruts or bumps. Uneven terrain could overturn the machine. Tall grass can hide obstacles.
- Use slow speed. Choose a low gear so that you will not have to stop or shift while on the slope.
- Follow the manufacturer's recommendations for wheel weights or counterweights to improve stability.
- Keep all movement on the slopes slow and gradual. Do not make sudden changes in speed or direction.
- Avoid starting or stopping on a slope. If tires lose traction, disengage the blades and proceed slowly straight down the slope.

#### DO NOT:

- Do not turn on slopes unless necessary, and then turn slowly and gradually downhill, if possible.
- Do not mow near drop-offs, ditches or embankments. The mower could suddenly turn over if a wheel is over the edge of a cliff or ditch, or if an edge caves in.
- Do not mow on wet grass. Reduced traction could cause sliding.

### III. CHILDREN

Tragic accidents can occur if the operator is not alert to the presence of children. Children are often attracted to the machine and the mowing activity. Never assume that children will remain where you last saw them.

- Keep children out of the mowing area and under the watchful care of another responsible adult.
- Be alert and turn machine off if children enter the area.
- Before and when backing, look behind and down for small children.
- Never carry children. They may fall off and be seriously injured or interfere with safe machine operation.
- Never allow children to operate the machine.
- Use extra care when approaching blind corners, shrubs, trees or other objects that may obscure vision.

### IV. SERVICE

- Use extra care in handling gasoline and other fuels. They are flammable and vapors are explosive.
  - Use only an approved container.
  - Never remove gas cap or add fuel with the engine running.
  - Allow engine to cool before refueling. Do not smoke near or while operating mower.
  - Never refuel the machine indoors.
  - Never store the machine or fuel container inside a room where there is an open flame, such as with a gas water heater.
- Never run a machine inside a closed area.
- Keep nuts and bolts, especially blade attachment nuts, tight and keep equipment in good condition.
- Never tamper with safety devices. Check their proper operation regularly.
- Keep machine free of grass, leaves or other debris build-up. Clean oil or fuel spillage. Allow machine to cool before storing.
- Stop and inspect the equipment if you strike an object. Repair, if necessary, before restarting.
- Never make adjustment or repairs with the engine running.
- Mower blades are sharp and can cut. Wrap the blade(s) or wear gloves, and use extra caution when servicing them.
- Check brake operation frequently. Adjust and service as required.



Look for this symbol to point out important safety precautions. It means **CAUTION!!! BECOME ALERT!!! YOUR SAFETY IS INVOLVED.**



**CAUTION:** Always disconnect spark plug wire and place wire where it cannot contact spark plug in order to prevent accidental starting when setting up, transporting, adjusting or making repairs.

Please read and keep this manual. The instructions will enable you to assemble and maintain your Power Mower properly. Always observe the "Safety Rules."

Record serial number and date of purchase in space provided below.

MODEL NUMBER: 486.243293

SERIAL NUMBER: \_\_\_\_\_

DATE OF PURCHASE: \_\_\_\_\_

The model and serial numbers will be found on a plate attached to the right side of the Drive Housing.

You should record both serial number and date of purchase and keep in a safe place for future reference.



**WARNING:** This unit is equipped with an internal combustion engine and should not be used on or near any unimproved forest-covered or grass-covered land unless the engine's exhaust system is equipped with a spark arrester meeting applicable local or state laws (if any). If a spark arrester is used, it should be maintained in effective working order by the operator.

In the state of California the above is required by law (Section 4442 of the California Public Resources Code). Other states may have similar laws. Federal laws apply on federal lands. A spark arrester for the muffler is available through your nearest Sears Authorized Service Center.

### PRODUCT SPECIFICATIONS

HORSEPOWER:	10.5
DISPLACEMENT:	21 CU. IN.
GASOLINE TYPE:	UNLEADED REGULAR
OIL TYPE (API-SF/SG):	SAE 30 (ABOVE 32°F) SAE 5W-30 (BELOW 32°F)
OIL CAPACITY:	28 OUNCES
SPARK PLUG:	(GAP: .030")
VALVE CLEARANCE:	INTAKE: .004 - .006 IN. EXHAUST: .004 - .006 IN.
BLADE BOLT TORQUE	35-40 FT. LBS.
TIRE PRESSURE	10 PSI
WIDTH OF CUT	42 INCHES

## CONTENTS OF CARTON

**PARTS PACKED SEPARATELY IN CRATE**

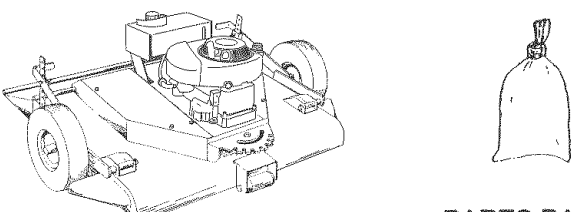

MOWER DECK

PARTS BAG

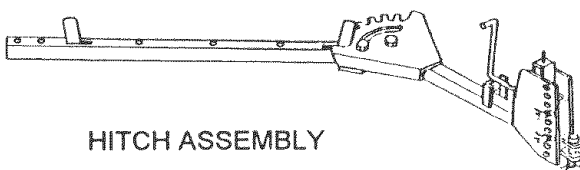

HITCH ASSEMBLY

**PARTS BAG CONTENTS**

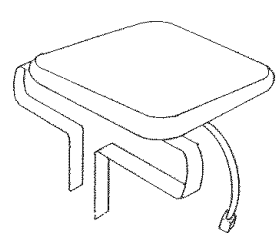

OPERATOR PRESENCE SEAT

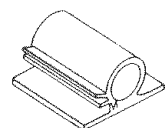

CABLE GUIDE (2)



3/8 CABLE CLIP (3)

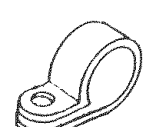

1/2 CABLE CLIP (3)

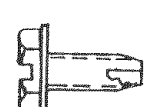

SCREW (3)

# ASSEMBLY

## REMOVING UNIT FROM CRATE

- Remove top boards.
- Remove two Bolts from front of crate which hold shipping anchors.
- Remove two Bolts from bottom at rear of crate which hold shipping anchors.
- Remove Hitch Assembly and Parts Bag from crate.
- Remove Roller Bolt from Front Roller, Remove shipping anchors and reinstall Roller Bolt.
- Remove Nuts from Height Adjustment Straps and remove shipping anchors from each side of mower. Reinstall Nuts to Height Adjustment Straps, then loosen 1/4 turn to allow straps to pivot freely.
- Check all loose parts and bag contents against Crate Contents and Bag Contents illustration on page 5. If any part is missing or damaged contact the store where you purchased the unit.



**CAUTION:** Before starting to assemble mower, remove spark plug wire from plug of mower engine.

## OPERATOR ORIENTATION

When right and left are mentioned in this manual, it means your right and your left when you are seated behind the wheel in the operating position.

## ENGINE OIL

### **VERY IMPORTANT:**

Engine must be filled with oil before operation. See OIL & FUEL RECOMMENDATIONS in engine Owner's Manual for correct filling instructions and oil fill capacity.

## INSTALL TOWBAR TUBE TO REAR QUADRANT

- Cut and remove the Plastic Tie which holds the Wire Harness and the Clutch Cable to the Rear Quadrant. (See Fig. 1)
- Remove two 3/8 Bolts, two 3/8 Lock Nuts and one 3/8 Flat Washer from the rear of the Towbar Tube.
- Place tube into Rear Quadrant, align holes, insert 3/8-16 x 2-1/2 Hex Bolt through rear hole of tube.
- Secure tightly with 3/8-16 Lock Nut then loosen Nut 1/4 turn to allow tube to pivot freely inside Rear Quadrant.
- Assemble a 3/8 Flat Washer onto a 3/8-16 x 2-1/2 Hex Bolt.
- Insert Bolt and Washer through slot of Rear Quadrant and hole in Towbar Tube.
- Secure tightly with 3/8-16 Lock Nut then loosen Nut 1/4 turn to allow tube to pivot freely inside Rear Quadrant.

**NOTE:** Towbar Tube must pivot freely inside Rear Quadrant when latch is pulled from notch.

## INSTALL CLUTCH CABLE AND WIRE HARNESS TO TOWBAR TUBE.

- Unwrap the Wire Harness and the Clutch Cable from around the Engine.
- Lay the Clutch Cable along the left side of the Towbar Tube and lay the Wire Harness along the right side of the Towbar Tube.
- Install three 3/8" Cable Clips on the Clutch Cable and three 1/2" Cable Clips onto the Wire Harness.
- Align all six Cable Clips with the holes in the Towbar Tube and secure them with three #10 Self-Tapping Screws.

## INSTALL CLUTCH CABLE TO THE HITCH ASSEMBLY

- Remove the 1/4" Lock Nut and 1/4" x 3/4" Bolt from the Clutch Cable Eyelet.
  - Screw one 5/16" Nut off the Clutch Cable Housing and onto the bare cable wire. Screw the second 5/16" Nut all the way onto the Clutch Cable Housing. Insert the Clutch Cable Eyelet through the slotted hole in the Cable Anchor on the Hitch Assembly.
- NOTE:** The loose 5/16" Nut on the cable wire must be cocked at an angle to fit through the slotted hole.
- Fasten the Clutch Cable Eyelet to the Clutch Lever, reusing the 1/4" x 3/4" Hex Bolt and 1/4" Lock Nut. Tighten the 1/4" Lock Nut securely and then loosen approximately two turns to allow the cable to pivot freely on the bolt.
  - Screw the loose 5/16" Nut back onto the Clutch Cable Housing. Use the 5/16" Nuts to adjust the cable to the proper tension.

### VERY IMPORTANT

See DRIVE TENSION on page 16 in the SERVICE AND ADJUSTMENTS Section of this manual for proper Clutch Cable adjustment.

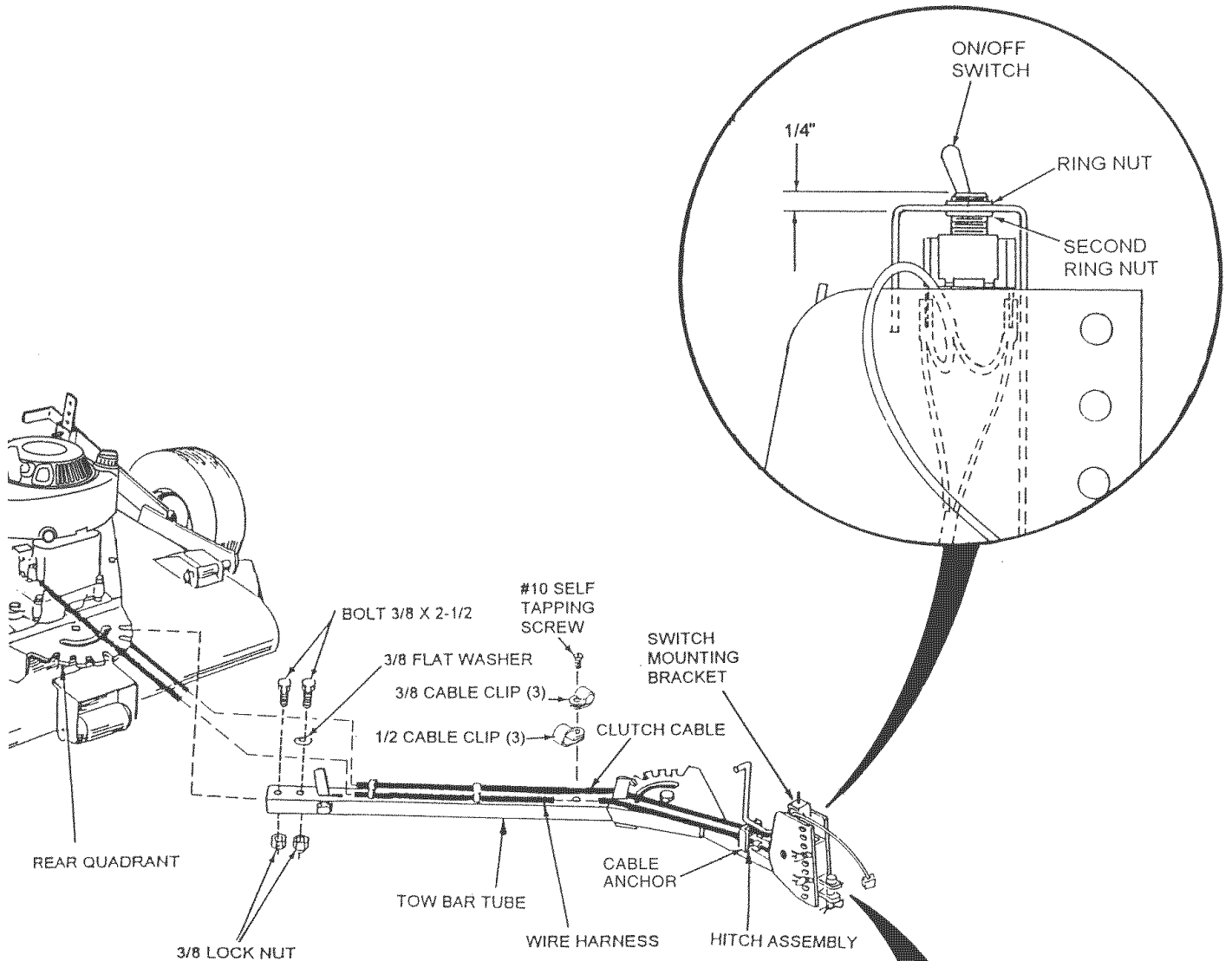

## INSTALL THE WIRE HARNESS AND THE ON/OFF SWITCH

- Slide the Wire Harness under the Cable Anchor of the Hitch Assembly.
- Connect two 1/4 Female Spade Connectors from the Wire Harness to the prongs of the ON/OFF Switch.
- Insert the Seat Switch Plug of the Wire Harness into the Hitch Assembly, Pulling it up and through the right top side of the Switch Mounting Bracket.
- Remove one Ring Nut from the ON/OFF Switch and adjust the second Ring Nut 1/4 Inch from the top of the threads.
- Insert the ON/OFF Switch up through the Switch Mounting Bracket and secure it by reinstalling the Ring Nut.

NOTE: The notch in the threads of the ON/OFF Switch must face toward the "ON" of the ON/OFF Switch Decal to insure proper ON/OFF control.

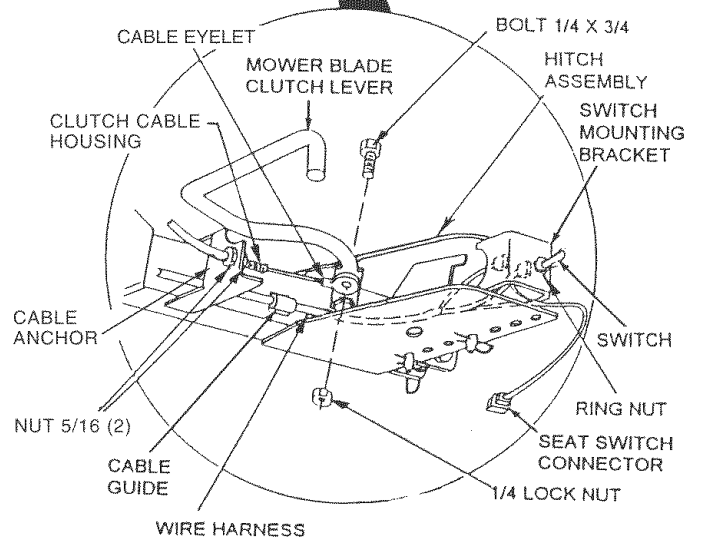

FIG. 1

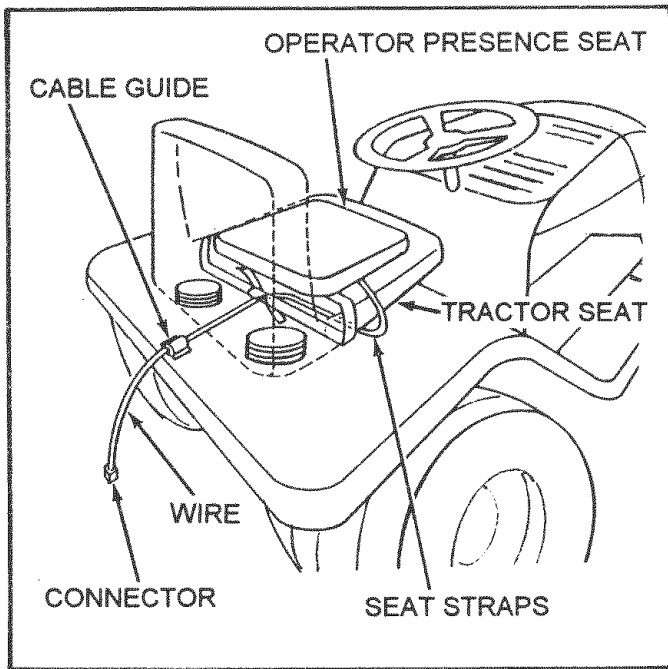

FIG. 1A

## INSTALL OPERATOR PRESENCE SEAT TO TRACTOR

Your Mower is equipped with and Operator Presence Seat to provide for your safety. The Operator Presence Seat must be installed on the seat of the tow vehicle and must be plugged in to the Wire Harness of the Mower for proper operation of this unit.

**NOTE:** In order to start the mower engine you must have the Operator Presence Seat plugged into the Wire Harness of the Mower and the Mower Blade Clutch Lever in the disengaged position. In order to engage the Mower Blades You must be seated on the Tow Vehicle and on the Operator Presence Seat.

- Place the Operator Presence Seat on the Tractor Seat with the Wire toward the bottom and secure with the seat strap. (See Fig. 1A)
- Lift Tractor Seat and install a cable guide in the middle of the Tractor rear fenders.
- Place Operator Presence Seat Wire into Cable Guide with the connector toward the rear so as to connect with the Seat Switch Plug of the Wire Harness.
- Lower Tractor Seat
- Connect Operator Presence Seat wire to the Seat Switch Plug of the Wiring Harness.

## WIRING DIAGRAM

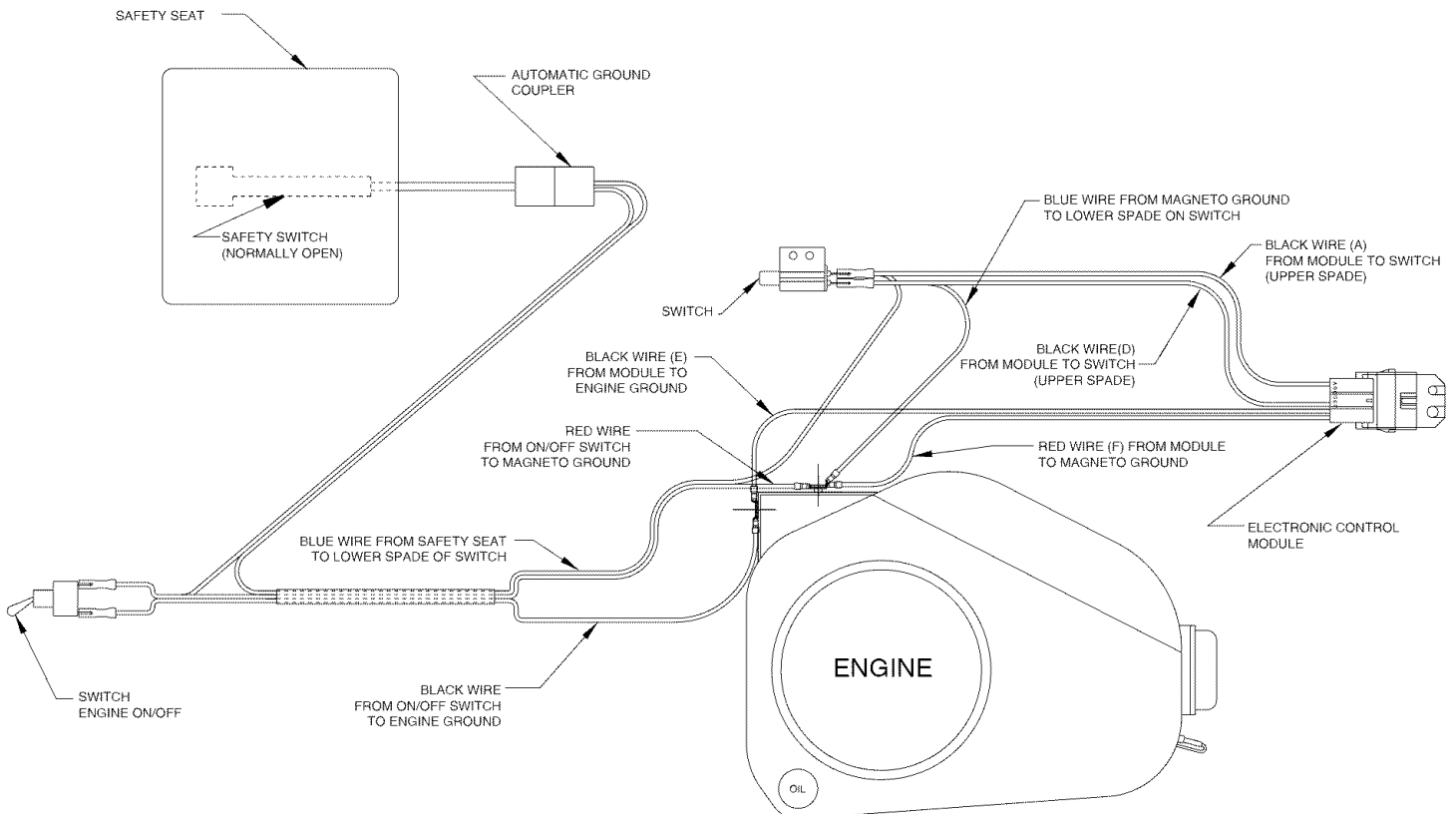



# OPERATION

## KNOW YOUR MOWER

READ THIS OWNER'S MANUAL AND SAFETY RULES BEFORE OPERATING YOUR MOWER.

Compare the illustrations with your mower to familiarize yourself with the location of various controls and adjustments. Save the manual for future reference.

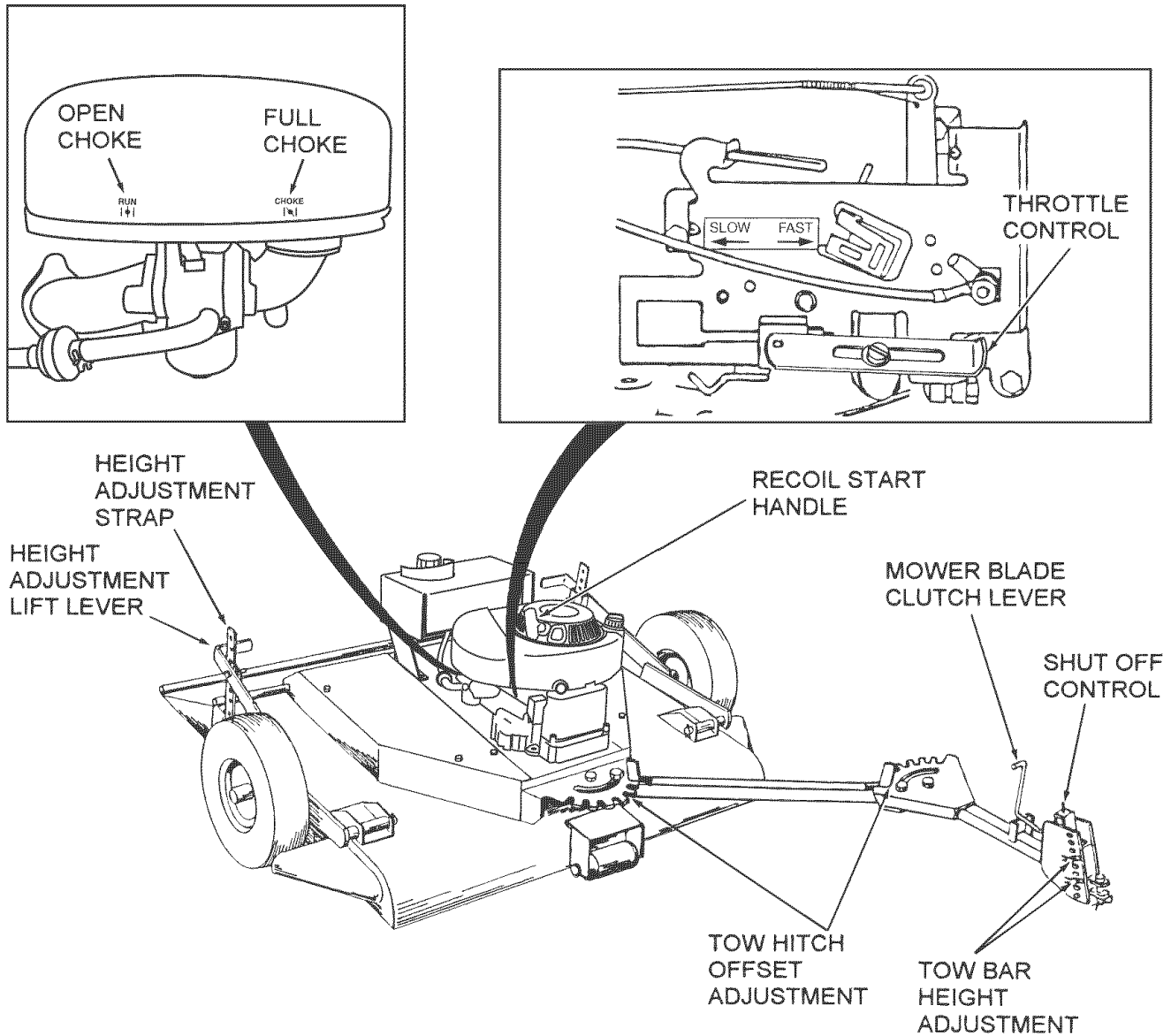

FIG. 2

**MOWER BLADE CLUTCH LEVER** - Starts and stops mower blade rotation

**THROTTLE CONTROL** - Controls engine speed, engine shut-off

**SHUT OFF CONTROL** - Used to shut off mower engine from tractor seat

**HEIGHT ADJUSTMENT LIFT LEVER** - Raise and lower mower to different cutting heights

**HEIGHT ADJUSTMENT STRAP** - Controls cutting height

**TOW BAR HEIGHT ADJUSTMENT** - To level mower front to rear

**RECOIL START HANDLE** - Used to start engine

**TOW HITCH OFFSET ADJUSTMENT** - To adjust mower deck offset from tractor center

**CHOKE CONTROL** - Opens and closes choke



The operation of any mower can result in foreign objects being thrown into the eyes, which can result in severe eye damage. Always wear safety glasses or eye shields before starting your mower and while mowing. We recommend wide vision safety mask for over the spectacles or standard safety glasses.

## CHILDREN



Tragic accidents can occur if the operator is not alert to the presence of children. Children are often attracted to the machine and the mowing activity. *Never* assume that children will remain where you last saw them.

## HOW TO USE YOUR MOWER

### STOPPING

- Move blade clutch lever to Off position.
- Move engine shut off switch to Off position.
- Move engine throttle to Stop position.

### STARTING

- Move engine shut off switch to On position.
- Move engine throttle to Full position.
- Move choke to full.
- Move blade clutch lever to Off position.
- Pull start rope.
- Move engine choke to Off position after engine starts.

### USE

- Sit on tractor seat.
- Raise blade clutch lever to Engage position.
- Operate tractor at medium ground speed. (3-4 MPH)
- Refer to Safety Rules on page 3 and to the Slope Guide on page 23 regarding operation of mower on slopes.

### TRANSPORTING

- Shut off engine.
- Place mower deck in the highest position directly behind tractor.



#### CAUTION:

Never operate the mower without discharge chute cover in its proper place.

## ATTACHING MOWER TO TRACTOR

- Place mower behind tractor and back tractor up to it for attaching. (See Fig. 3)
- Slide tow bar of mower over tractor drawbar so that the hitch pin holes line up.
- Insert hitch pin until it extends through the bottom of the tow bar.
- Insert hair cotter pin through hitch pin.

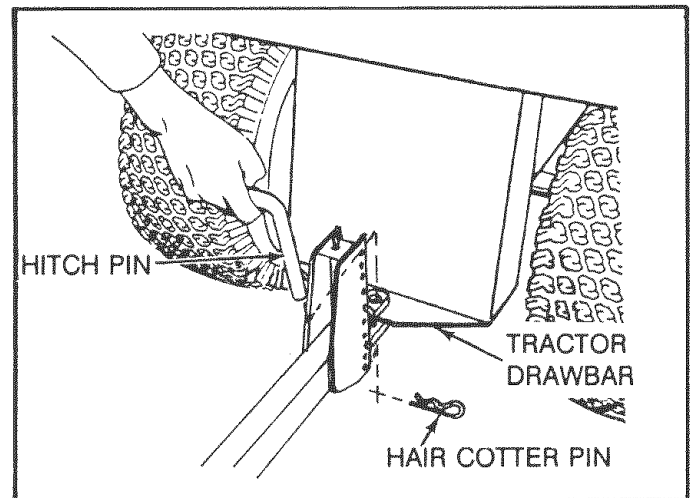

FIG. 3

## MOWER HEIGHT ADJUSTMENT



### CAUTION:

Shut off mower engine and remove spark plug wire from spark plug before making any adjustments to mower.

The cutting height range is approximately 1-1/2 to 4-1/2 inches. The heights are measured from the ground to the blade tip with the engine not running. These heights are approximate and may vary depending upon soil conditions, height of grass and types of grass being mowed.

- The average lawn should be cut to approximately 2-1/2 inches during the cool season and to over 3 inches during hot months. For healthier and better looking lawns, mow often and after moderate growth.
- For best cutting performance, grass over 6 inches in height should be mowed twice. Make the first cut relatively high, the second to desired height.

## CUTTING HEIGHT ADJUSTMENTS



### CAUTION:

Shut off mower engine and remove spark plug wire from spark plug before making any adjustments to mower.

- To adjust the mower cutting height remove hair cotter pin from clevis pin in the height adjustment strap. (See Fig. 4)
- Apply down pressure to height adjustment lift lever.
- Remove the clevis pin from the height adjustment strap.
- Move height adjustment strap up or down to align it with the desired hole in the height adjustment strap.
- Reassemble clevis pin to the height adjustment strap and secure with hair cotter pin.
- Make sure that both side height adjustment straps are adjusted to the same height.

## FRONT TO BACK RAKE ADJUSTMENT

To obtain the best cutting results, the mower housing should be adjusted so that the front is approximately 1/4" to 3/4" lower than the rear. To check front to back adjustment measure from the bottom edge of the deck to the ground at both front and rear of the deck.

## TO ADJUST MOWER FROM FRONT TO BACK

- Remove two hair cotter pins from two clevis pins in the tow bar adjustment. (See Fig. 4)
- Remove two clevis pins from tow bar adjustment.
- Raise or lower the tow bar to obtain the proper front to back adjustment.
- Reassemble two clevis pins to tow bar adjustment and secure with two hair cotter pins.

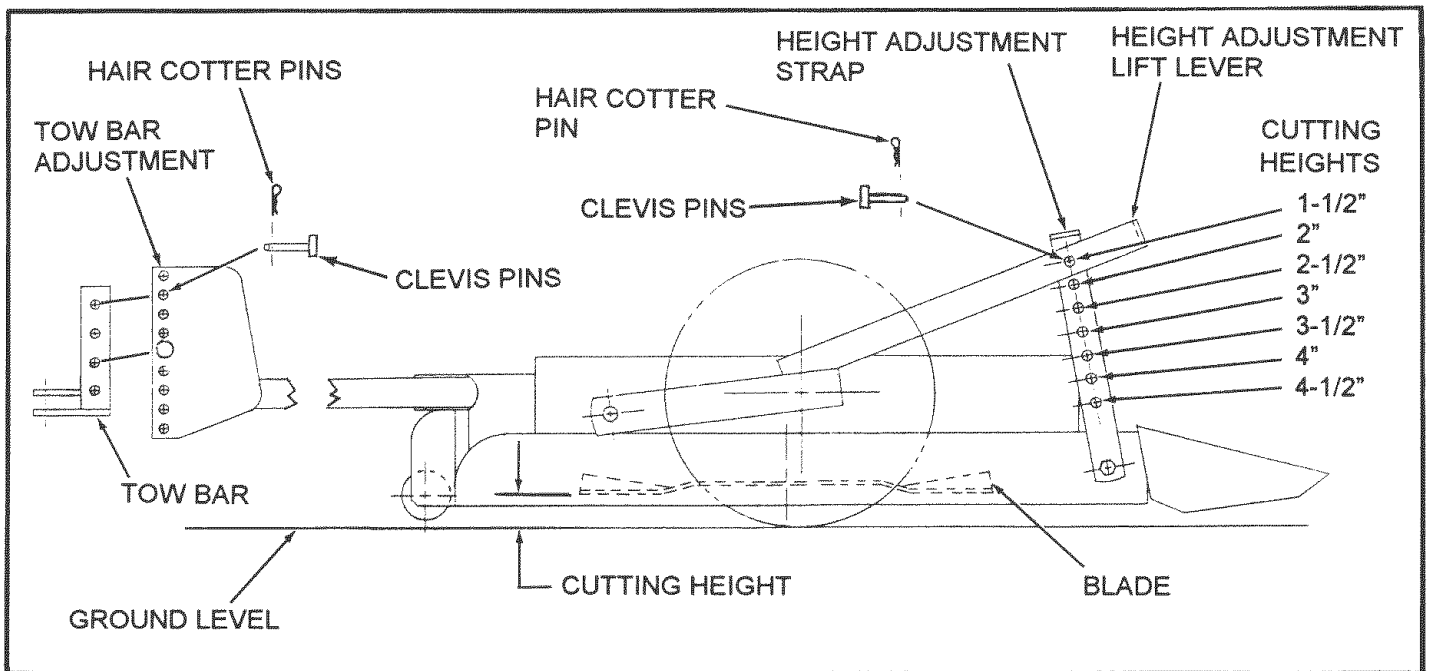

FIG. 4

## TOW HITCH OFFSET ADJUSTMENT

This tow behind mower has been designed to run offset from the center of the tow vehicle to give additional cutting width.

- The adjustable tow hitch of this mower can be set in four positions, straight, Approximately 15" offset, 29" offset and 39" offset to either side. (See Fig. 5)
- When cutting with a tow vehicle already equipped with a 42", 46", or 50" mower, we recommend using the 39" offset. When cutting with a tow vehicle equipped with 36", 38" or 40" mower, use the 29" offset position. When cutting heavier grass or when conditions warrant, adjust the mower to the 15" offset position.
- If tow vehicle is not equipped with a mid mount mower the hitch can be adjusted to a straight position, but we recommend using the offset position to eliminate grass being crushed down by the tow vehicle.

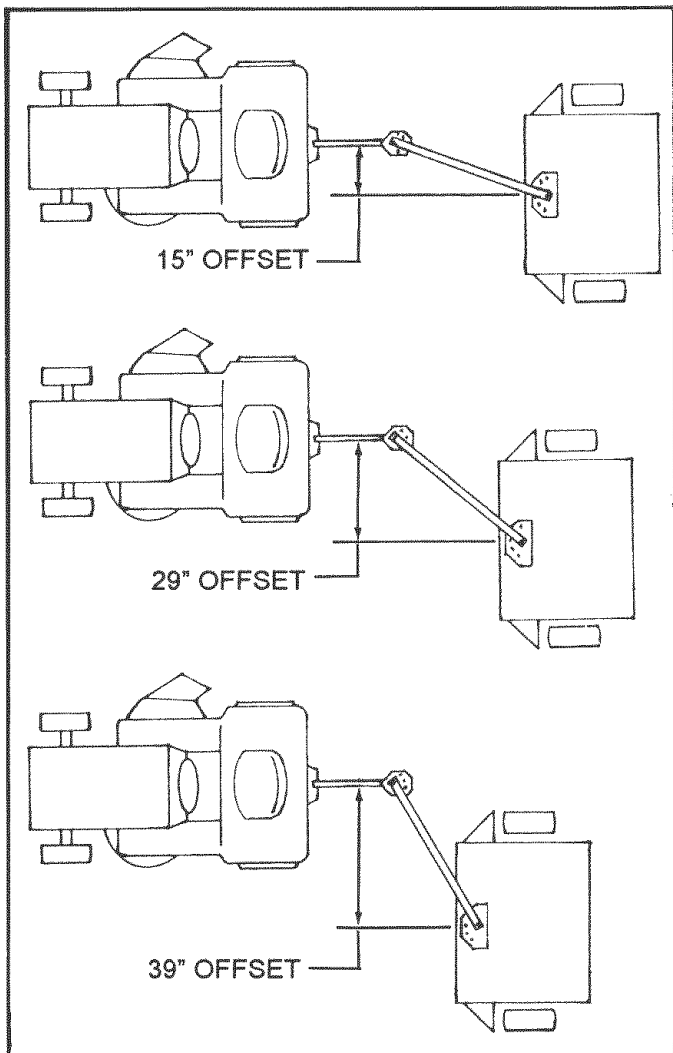



FIG. 5

**CAUTION:**  
 Shut off mower engine and remove spark plug wire from spark plug before making any adjustments to mower.

## TO ADJUST THE OFFSET HITCH

- Pull back the pivot latch from the notch of the front quadrant. Adjust the hitch tube to the desired offset and release the pivot latch into the notch of the quadrant. (See Fig. 6)
- Pull back the pivot latch from the notch of the rear quadrant. Adjust the hitch tube to the corresponding notch of the front quadrant and release the pivot latch into the notch.

**IMPORTANT:** The hitch tube must be assembled to the same offset notch in both the front and rear quadrants.

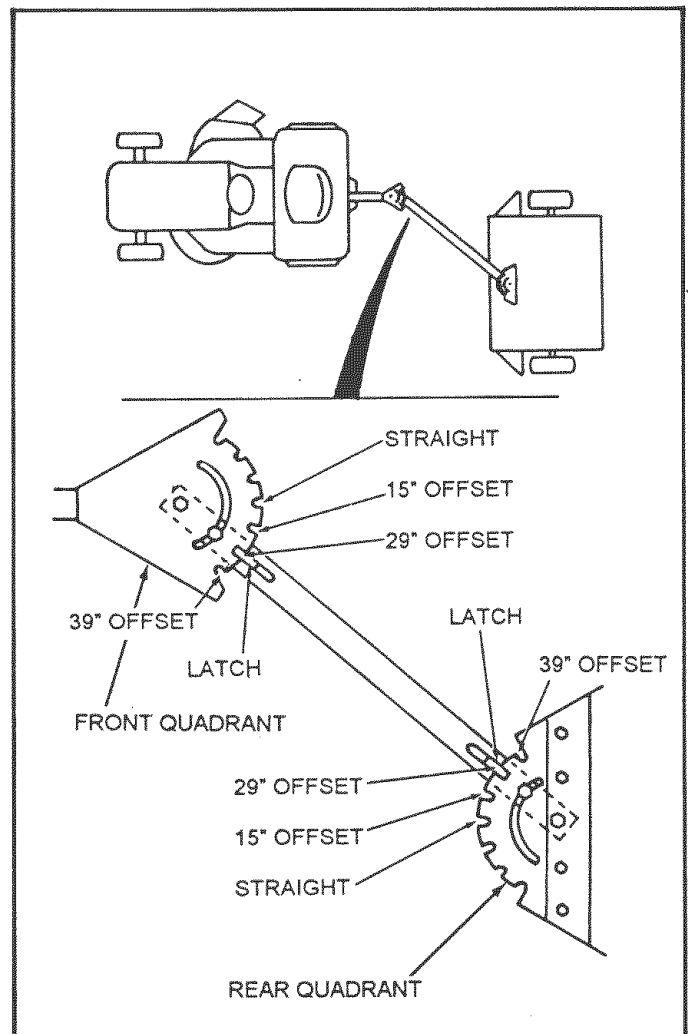

FIG. 6

## BEFORE STARTING ENGINE

- Fill engine with oil. (See engine manual for proper procedure and requirements)
- Add gasoline. Fill fuel tank using fresh clean unleaded gasoline. (See tractor manual for safe filling procedure and storage instructions)



### CAUTION:

Fill to bottom of fuel tank filler neck. Do not overfill. Wipe off any spilled oil or fuel. Do not store, spill or use gasoline near open flame.

## TO START ENGINE



### CAUTION:

Keep the blade clutch lever in "Disengaged" position when starting engine

- Make sure spark plug wire is properly connected.
- Place choke control in "CHOKE" position if the engine is cold. A warm engine may not require choking to start.
- Move engine throttle to full position.
- Grasp starter handle with one hand. Pull rope out slowly until engine reaches start of compression cycle (rope will pull slightly harder at this point)
- Pull roper with a rapid, continuous, full arm stroke.
- Keep a firm grip on starter handle and let rope rewind slowly. Do not let starter handle snap back against starter.
- When engine starts move choke to open position.
- Allow engine to warm up for a few minutes before engaging blades.

**NOTE:** If at a high altitude (above 3000 feet) or in cold temperatures (below 32°F), the carburetor fuel mixture may need to be adjusted for best performance. (See Service and Adjustments section of the engine manual.

## BREAKING IN YOUR MOWER

Break in your belts, pulleys, and engine before you actually begin mowing.

- Start engine, engage blade control to start blades rotating and allow blades to rotate for approximately five minutes to break in mower and engine.



### CAUTION:

Check area under and around mower for any objects that could be thrown from under mower. Make sure that mower discharge area is clear.

## MOWING PROCEDURES



### CAUTION:

Tragic accidents can occur if the operator is not alert to the presence of children. Children are often attracted to the machine and the mowing activity. **NEVER** assume that children will remain where you last saw them.



### CAUTION:

**NEVER** carry children. They may fall off and be seriously injured or interfere with safe operation.

**IMPORTANT:** Avoid prolonged mowing of ditches with slopes greater than 15 degrees. Small engines become starved for oil at angles greater than 15 degrees and should only be used for brief periods on such slopes. Be sure the engine is tilted to the maximum oil level when mowing on slopes.

- Mowing should be started with tractor in low gear and speed increased only as mowing conditions will safely permit.
- Mower will perform at its best when engine throttle is set for full throttle.
- You will obtain better mowing results in grassy areas if they are mowed when the grass is approximately 4" to 5" maximum height. While your mower will cut grass taller than 5", you will notice a substantial increase in engine power required and some change in the finished appearance of the area mowed.
- Mowing conditions will vary from place to place, including the types of grass which are being mowed, such as fine stalk, coarse stalk, and dense or sparse grasses. When mowing tall grass you may find that certain grasses may be pressed downward under the wheels so that they will not mow properly. If this condition exists you may have to mow the area twice, the first mowing with the mower raised and the second mowing at the desired height. If it is practical, you will achieve better results if the second mowing is at right angle to the previous mowing.
- Do not mow grass when it is wet. Wet grass will plug mower and leave undesirable clumps. Allow grass to dry before mowing.
- Always operate mower engine at full throttle when mowing to assure better mowing performance and proper discharge of material. Regulate ground speed by selecting a gear low enough to give the best cutting performance and quality of cut.
- When operating any attachment, select a ground speed that will suit the terrain and give the best performance for the attachment being used.
- When mowing slopes, always mow them up and down at slow speed. Never mow across slopes. Refer to Slope Operation on page 3 and to the Slope Guide on page 23.

# MAINTENANCE

## GENERAL RECOMMENDATIONS

The warranty on this Vehicle does not cover items that have been subjected to operator abuse or negligence. To receive full value from the warranty, operator must maintain unit as instructed in this manual.

Some adjustments will need to be made periodically to properly maintain your unit. All adjustments in the Service and Adjustments section of this manual should be checked at least once each season.

- Once a year you should replace the spark plug, clean or replace air filter, and check blades and belts for wear. A new spark plug and clean air filter assure proper air-fuel mixture and help your engine run better and last longer.

## BEFORE EACH USE

- Check engine oil level.
- Check blade operation
- Check for loose fasteners.

MAINTENANCE SCHEDULE	SERVICE DATES																						
	BEFORE EACH USE	FIRST 2 HOURS	EVERY 5 HOURS	EVERY 25 HOURS OR EACH YEAR																			
FILL IN DATES AS YOU COMPLETE REGULAR SERVICE																							
Check Engine Oil Level	✓		✓																				
Change Engine Oil		✓		✓ <sup>1,2</sup>																			
Inspect Spark Arrester Muffler				✓																			
Inspect Air Screen	✓																						
Check and Clean Air Cleaner			✓																				
Replace Air Cleaner Cartridge				✓ <sup>2</sup>																			
Clean Engine Cylinder Fins				✓																			
Replace Spark Plug				✓																			
Lubricate Spindles				✓																			

1 - Change more often when operating under a heavy load or in high ambient temperatures.  
 2 - Service more often when operating in dirty or dusty conditions.

## ENGINE MAINTENANCE

Refer to engine manual when performing maintenance on engine.

## LUBRICATION

- ① REFER TO ENGINE MANUAL
- ② GENERAL PURPOSE GREASE

**IMPORTANT:** Do not oil or grease pivot points. Viscous lubricants will attract dust and dirt that can cause wear on pivot points. If you feel they must be lubricated, use only a dry powdered graphite type lubricant.

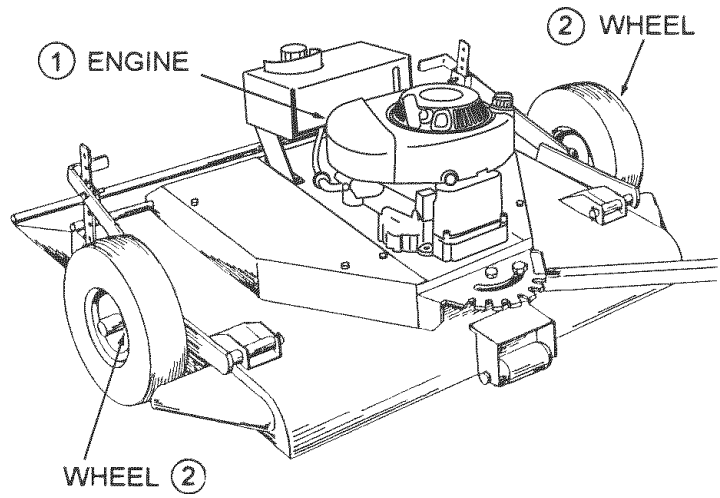

## CLEANING THE MOWER



**CAUTION:** Disconnect spark plug wire from spark plug before working on underside of mower.

- Clean the underside of your mower to remove buildup of grass clippings.
- Clean any gasoline, oil, or foreign matter from engine, painted surfaces and wheels.
- We do not recommend using a garden hose to clean mower unless the electrical system, muffler, air filter and carburetor are covered to keep water out. Water in engine can result in shortening engine life.

## BLADE CARE

- For best results, mower blade must be kept sharp. The blades can be sharpened with a few strokes of a file or on a grinding wheel. Do not attempt to sharpen blades while blades are on mower.
- To remove blade for sharpening, use wooden block to hold blade while removing the blade mounting nut. The nuts have right hand threads. (See Fig. 7.)



**CAUTION:** Do not handle mower blades with bare hands. Careless or improper handling may result in serious injury.

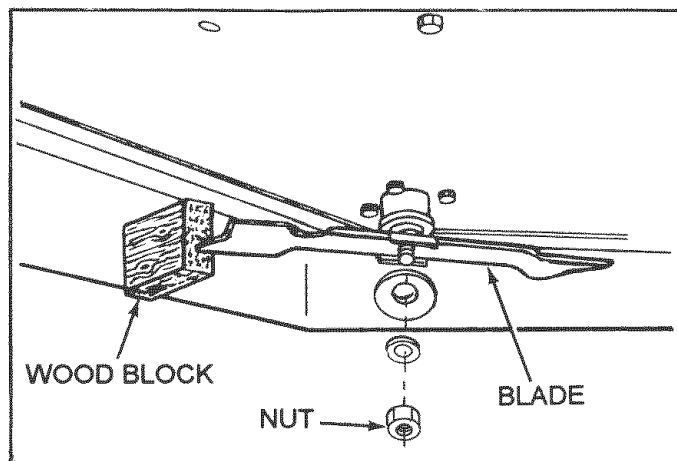

FIG. 7

- When grinding, take care to maintain blade balance. Check blade for proper balance before reinstalling to mower.
- To check and balance blade use a balancing machine or, fixture as shown in figure 8. File material off heavier end of blade until it is balanced.

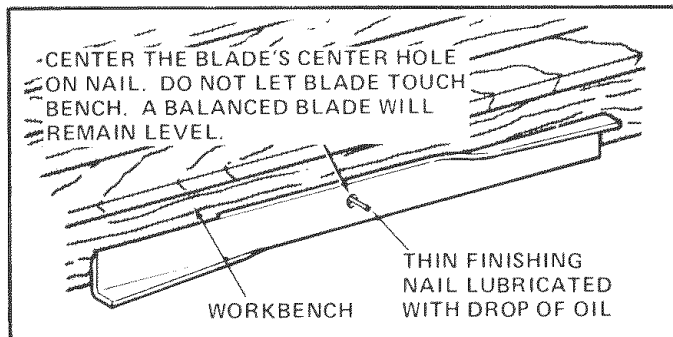

FIG. 8

To assure satisfactory operation, we recommend that you discard old blades and replace them with new ones before the start of each mowing season.

**NOTE:** Check nuts and blades occasionally to make sure nuts are tight.



**CAUTION:** Shut off mower engine and remove spark plug wire from spark plug before making any adjustments or repairs to mower.

# SERVICE AND ADJUSTMENTS

## REPAIR PARTS

Your rotary mower has been produced with components designed for your unit. Although standard V-belts, bearings, blades pulleys etc. may look like the parts used on your rotary mower, many are of a different construction and could in some cases cause the mower to malfunction.

For continued satisfactory performance, use only repair parts supplied by the manufacturer. See you Sears Service Center for replacement parts.

## BELT REPLACEMENT



**CAUTION:** Disconnect spark plug wire from spark plug before replacing V-belt.

- Move Blade Clutch Lever to the "DISENGAGED" position.
- Remove two belt covers. (See Fig 9)
- Loosen three bolts and pivot belt guides away from pulleys
- Move belt brake away from spindle pulleys, and remove V-belt from around two spindle pulleys.
- Remove V-belt from around engine pulley.
- Disconnect small spring from idler arm.
- Grasp body of large idler spring and pull spring to the right side of mower until idler pulley is against spindle pulley.
- Remove V-belt from idler pulley.
- Place new V-belt onto idler pulley and release large spring to allow idler to return to original position.
- Reconnect small spring to idler arm.
- Assemble V-belt around engine pulley.
- Move belt brake away from spindle pulleys then assemble V-belt onto spindle pulleys.
- Place Blade Clutch Lever into "ENGAGED" position.
- Reposition three belt guides to original position with approximately 1/16" clearance from pulleys and retighten bolts to secure belt guides.

**NOTE:** Belt Guides should not touch V-belt or pulleys when unit is in engaged position.

- Reassemble two belt covers and return Blade Clutch Lever to "DISENGAGED" position.

## CHECKING DRIVE TENSION

- Remove V-belt cover from right side of unit.
- Place Blade Control Lever in the "ENGAGED" position.
- Check tension spring length. It should be 5-3/8" to 5-5/8" over the coils of the Spring Body. See Fig. 9.

## ADJUSTING DRIVE TENSION

### To Increase Drive Spring Tension

- Place blade clutch lever in the "DISENGAGED" position.  
Loosen the inner nut of the clutch cable.  
Tighten the outer nut to increase spring tension.

**NOTE:** For every 1/8" adjustment made to the cable you will get approximately 1/8" movement on the tension spring.

### To Decrease Drive Spring Tension

- Place blade clutch lever in the "DISENGAGED" position.
- Loosen the outer nut of the clutch cable.
- Tighten the inner nut to decrease spring tension.



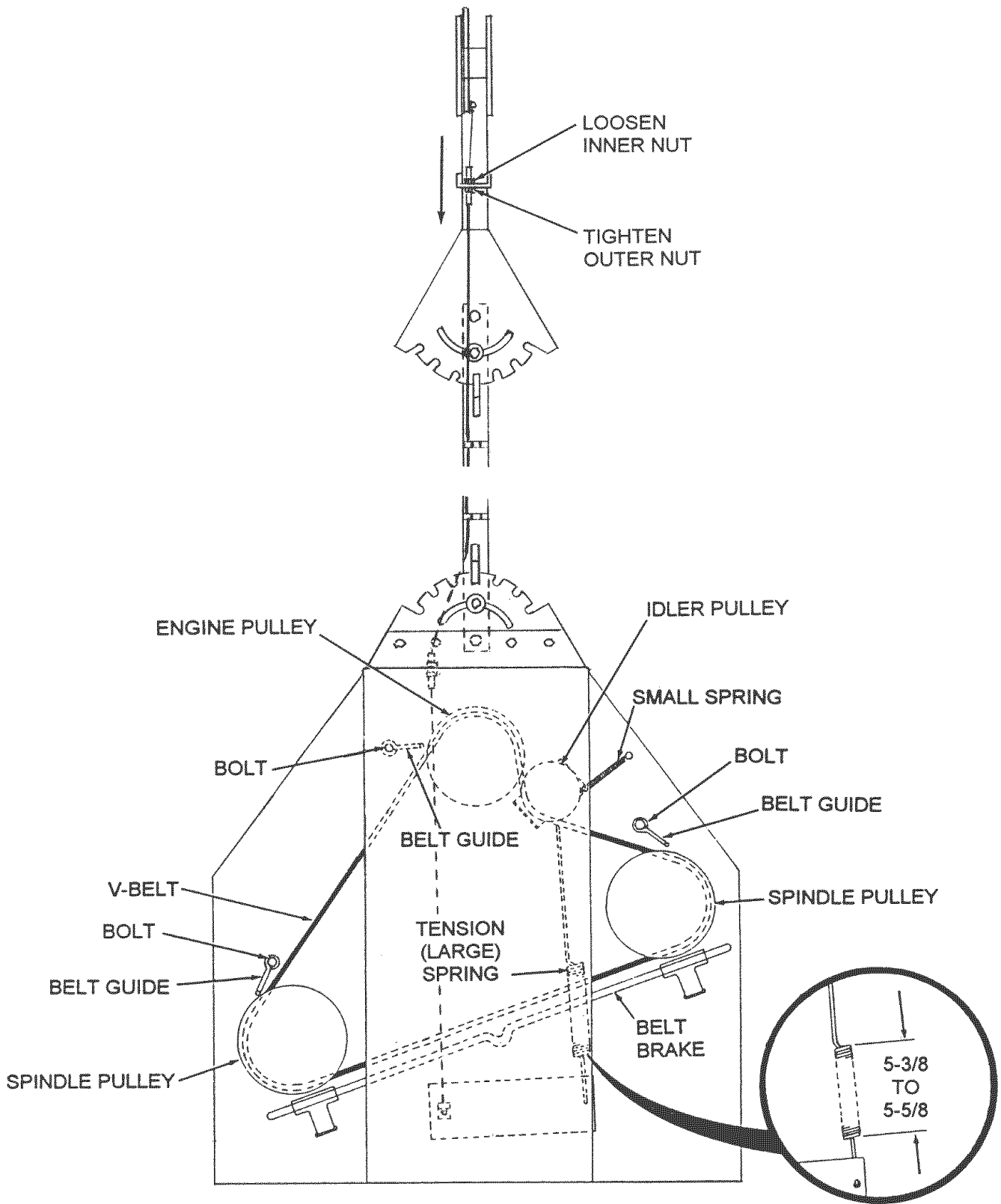

FIG. 9

## STORAGE

Immediately prepare your mower for storage at the end of the season or if the unit will not be used for 30 days or more.

### MOWER

When the mower is to be stored for a period of time, clean it thoroughly, remove all dirt, grease, leaves, etc. Store in a clean dry area.

- Clean entire mower (See "CLEANING")
- Lubricate as shown in the Customer Responsibilities section of this manual.
- Be sure that all nuts, bolts, screws, and pins are securely fastened. Inspect moving parts for damage, breakage and wear. Replace if necessary.
- Touch up all rusted or chipped paint surfaces; sand lightly before painting.

### CLEANING



**CAUTION:** Disconnect spark plug wire from spark plug before working on underside of mower.

- Clean the underside of your mower to remove build-up of grass and trash.
- Keep finished surfaces and wheels free of all gasoline, oil, etc.
- We do not recommend using a garden hose to clean mower unless the electrical system, muffler, air filter, and carburetor are covered to keep water out. Water in engine can result in shortening engine life.

### ENGINE

- Never use engine or carburetor cleaner products in the fuel tank or permanent damage may occur.
- Use fresh fuel next season.

**NOTE:** Fuel stabilizer is an acceptable alternative in minimizing the formation of fuel gum deposits during storage. Add stabilizer to gasoline in fuel tank or storage container. Always follow the mix ratio found on stabilizer container. Run engine at least 10 minutes after adding stabilizer to allow the stabilizer to reach the carburetor. Do not drain the gas tank and carburetor if using fuel stabilizer.

### ENGINE OIL

Drain oil with engine shut off but still warm. Replace old oil with new engine oil. (See engine manual.)

### CYLINDER

- Remove spark plug.
- Pour one ounce (29 ml) of oil through spark plug hole into cylinder.
- Pull starter handle slowly a few times to distribute oil.
- Replace with new spark plug.

### OTHER

- Do not store gasoline from one season to another.
- Replace your gasoline can if your can starts to rust. Rust and/or dirt in your gasoline will cause problems.
- If possible, store your unit indoors and cover it to give protection from dust and dirt.
- Cover your unit with a suitable protective cover that does not retain moisture. Do not use plastic. Plastic cannot breathe which allows condensation to form and will cause your unit to rust.



**CAUTION:** Never cover mower while engine and exhaust are still warm. Cover may ignite, causing a fire.



**CAUTION:** Never store a mower with gasoline in its tank inside a building where fumes may reach an open flame or spark. Allow the engine to cool before storing in any enclosure.

# NOTES

# 42" TOW BEHIND MOWER - MODEL NO. 486.243293

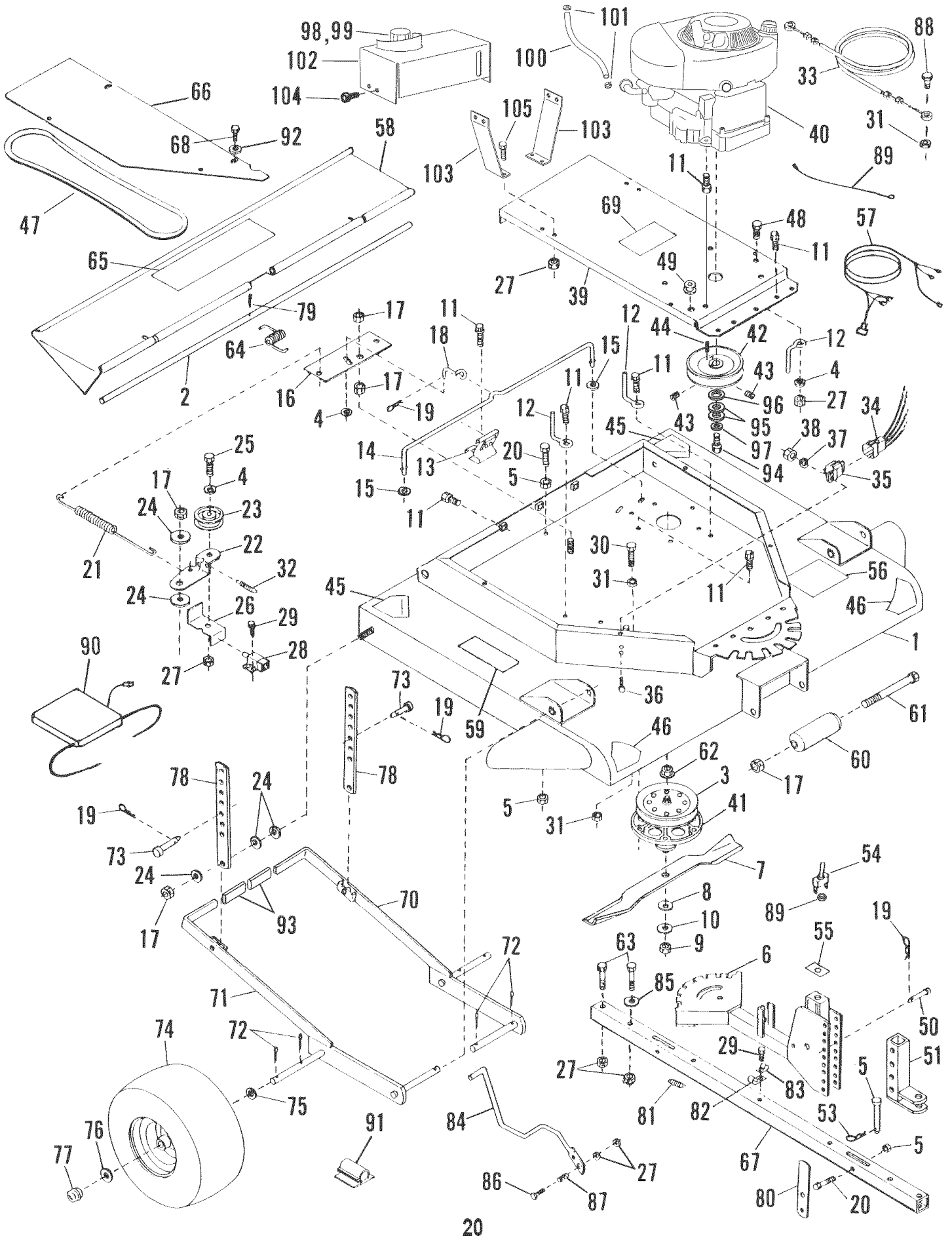

# 42" TOW BEHIND MOWER - MODEL NO. 486.243293

Item No.	Part No.	Description	Qty. Req.	Item No.	Part No.	Description	Qty. Req.
1.	HA23834	Mower Deck Pan.....	1	67.	HA23526	Hitch Tube.....	1
2.	HA23598	Rod- Deflector Mounting.....	1	68.	48840	Self Tapping Screw.....	8
3.	49112	Pulley (included with item 41).....	2	69.	HA12314	Danger Decal.....	1
4.	43081*	Washer, 3/8" x 7/8" x .08".....	3	70.	HA22996	Left Hand Wheel Mounting Bracket.....	1
5.	43064*	Nut - 5/16-18 Hex Lock.....	8	71.	HA22997	Right Hand Wheel Mounting Bracket.....	1
6.	HA23519	Hitch Assembly.....	1	72.	714-0121	Cotter Pin.....	8
7.	HA23516	Mower Blade.....	2	73.	HA23638	Clevis Pin.....	2
8.	HA23246	Belleville Washer.....	2	74.	47081	Wheel.....	2
9.	HA124634*	Nut, 9/16-18 Hex.....	2	75.	HA456151	Flat Washer, 13/16" x 1-1/2" x .134".....	2
10.	HA20129	Flat Washer.....	2	76.	HA23263	Flat Washer.....	2
11.	HA23193	Screw, 3/8-16 x 1-1/4 Thread Forming.....	25	77.	HA23229	Hub Cap.....	2
12.	HA22981	Belt Guide.....	4	78.	HA23646	Height Adjustment Strap.....	2
13.	HA64064	Brake Spring Assembly.....	1	79.	44101*	Cotter Pin, 3/32" x 3/4".....	1
14.	HA22987	Brake Rod.....	1	80.	HA24441	Strap, Latch.....	2
15.	HA120389	Washer, 1/2" x 1-1/4" x .083".....	2	81.	HA20186	Spring, Latch.....	2
16.	HA23518	Clutch Bellcrank.....	1	82.	HA23760	Clip - Hose/Cable 1/2".....	3
17.	43262*	Nut, 1/2-13 Hex Lock.....	6	83.	HA23761	Clip - Hose/Cable 3/8".....	3
18.	HA22948	Brake Release Rod.....	1	84.	HA23527	Lever - Clutch.....	1
19.	47134	Hair Cotter Pin.....	5	85.	HA15200	Washer, 13/32" x 1-3/16" x 3/16".....	2
20.	44180	Bolt, 5/16-18 x 2" Hex Head Grade 5.....	3	86.	43062*	Bolt, 3/8-16 x 1-1/2" Hex Head.....	1
21.	HA23196	Idler Tension Spring.....	1	87.	HA19445	Spring.....	1
22.	HA23258	Idler Bracket.....	1	88.	43012*	Bolt, 1/4-20 x 3/4" Hex Head.....	2
23.	HA15015	Idler Pulley.....	1	89.	HA23832	Wire.....	1
24.	HA6979	Flat Washer.....	8	90.	HA23586	Operator's Presence Seat.....	1
25.	41576*	Bolt, 3/8-16 x 1-3/4" Hex Head.....	1	91.	HA11947	Cord Clip.....	2
26.	HA23197	Interlock Bracket.....	1	92.	43088	Washer, 1/4" Std.....	4
27.	43082*	Nut, 3/8-16 Hex Lock.....	4	93.	47707	Grip - Handle.....	2
28.	HA17322	Interlock Switch.....	1	94.	HA181668*	Bolt, 7/16-20 x 1-1/4" Hex Head.....	1
29.	HA9411666*	Screw, #10-16 x 1/2" Self Tapping.....	6	95.	HA4143	Washer, 1" x 13/16" Thick.....	2
30.	43648*	Bolt, 1/4-20 x 1-1/2" Hex Head.....	1	96.	43601	Washer, 1.59" x 1.032" x .06".....	1
31.	43013*	Nut, 1/4-20 Hex Lock.....	8	97.	HA120389	Washer, 1/2" x 1-1/4" x .083".....	3
32.	HA3293	Extension Spring.....	1	98.	HA23732	Tank, Gasoline.....	1
33.	HA24617	Clutch Cable.....	1	99.	HA23733	Cap, Gasoline Tank.....	1
34.	HA23253	Module Connector.....	1	100.	48837	Fuel Line.....	1
35.	HA23252	Module.....	1	101.	HA23792	Clamp, Fuel Line.....	2
36.	45040*	Screw, #10-24 x 1/2" Pan Head.....	2	102.	25051	Cover, Gas Tank.....	1
37.	736-0722*	Washer, #10 Med. Lock.....	2	103.	25052	Bracket, Tank Mounting.....	2
38.	712-0121*	Nut, #10-24 Hex.....	2	104.	48795	Screw, 1/4" x 1-1/4" Self Tapping.....	4
39.	HA23513	Engine Mounting Plate.....	1	105.	43182	Bolt, Hex 5/16-18 x 3/4".....	4
40.	2157020115-E1	10.5 HP Engine.....	1	NP	48839	Owner's Manual	
41.	64675	Spindle Assembly (see page 22).....	2				
42.	HA22994	Pulley.....	1				
43.	HA115321*	Set Screw, 5/16-18 x 5/16" Socket Hd.....	2				
44.	HA3073	Square Key.....	1				
45.	HA17285	Danger Decal.....	2				
46.	HA12315	Danger Decal.....	2				
47.	HA22980	V-Belt.....	1				
48.	43001*	Bolt, 3/8-16 x 1" Hex Head.....	1				
49.	HA19484	Rubber Grommet.....	1				
50.	HA23636	Clevis Pin.....	2				
51.	HA23644	Towbar Assembly.....	1				
52.	HA20988	Hitch Pin.....	1				
53.	714-0117	Hair Cotter Pin.....	1				
54.	45084	On/Off Switch.....	1				
55.	HA23262	Decal - Engine Shut Off.....	1				
56.	HA23647	Clutch Lever Decal.....	1				
57.	HA23612	Wire Harness.....	1				
58.	HA23597	Deflector.....	1				
59.	HA23755	Decal - Operation.....	1				
60.	HA12138	Mower Roller.....	1				
61.	HA126145*	Bolt, 1/2-13 x 7" Hex Head.....	1				
62.	49110	Nut, Special (included with item 41).....	2				
63.	43432*	Bolt, 3/8-16 x 2-1/2" Hex Head.....	4				
64.	HA12988	Deflector Spring.....	1				
65.	44059	Sears Logo Decal.....	1				
66.	HA23645	Belt Cover.....	2				

\*Standard Hardware - Purchased Locally

# 42" TOW BEHIND MOWER - MODEL NO. 486.243293

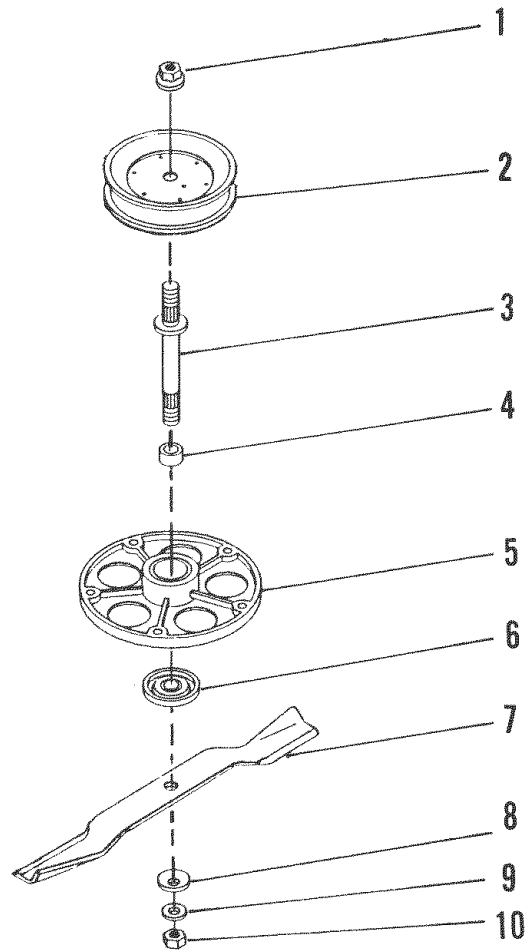

Item No.	Part No.	Description	Qty. Req.
1-6	64675	Spindle Assembly.....	1
1.	49110	Nut, 9/16-18 Special.....	1
2.	49112	Pulley .....	1
3.	49109	Jackshaft .....	1
4.	49111	Spacer.....	1
5.	HA23242	Housing & Bearing Assembly.....	1
6.	HA23245	Blade Adapter .....	1
7.	HA23516	Mower Blade .....	1
8.	HA23246	Belleville Washer .....	1
9.	HA20129	Thrust Washer.....	1
10.	HA124634	Nut, 9/16-18 .....	1

# SLOPE GUIDE

(Keep this sheet in a safe place for future reference.)  
Use this guide to determine if a slope is safe for the operation of your tractor and TOW BEHIND MOWER. Refer also to the instructions in your vehicle owners manual.

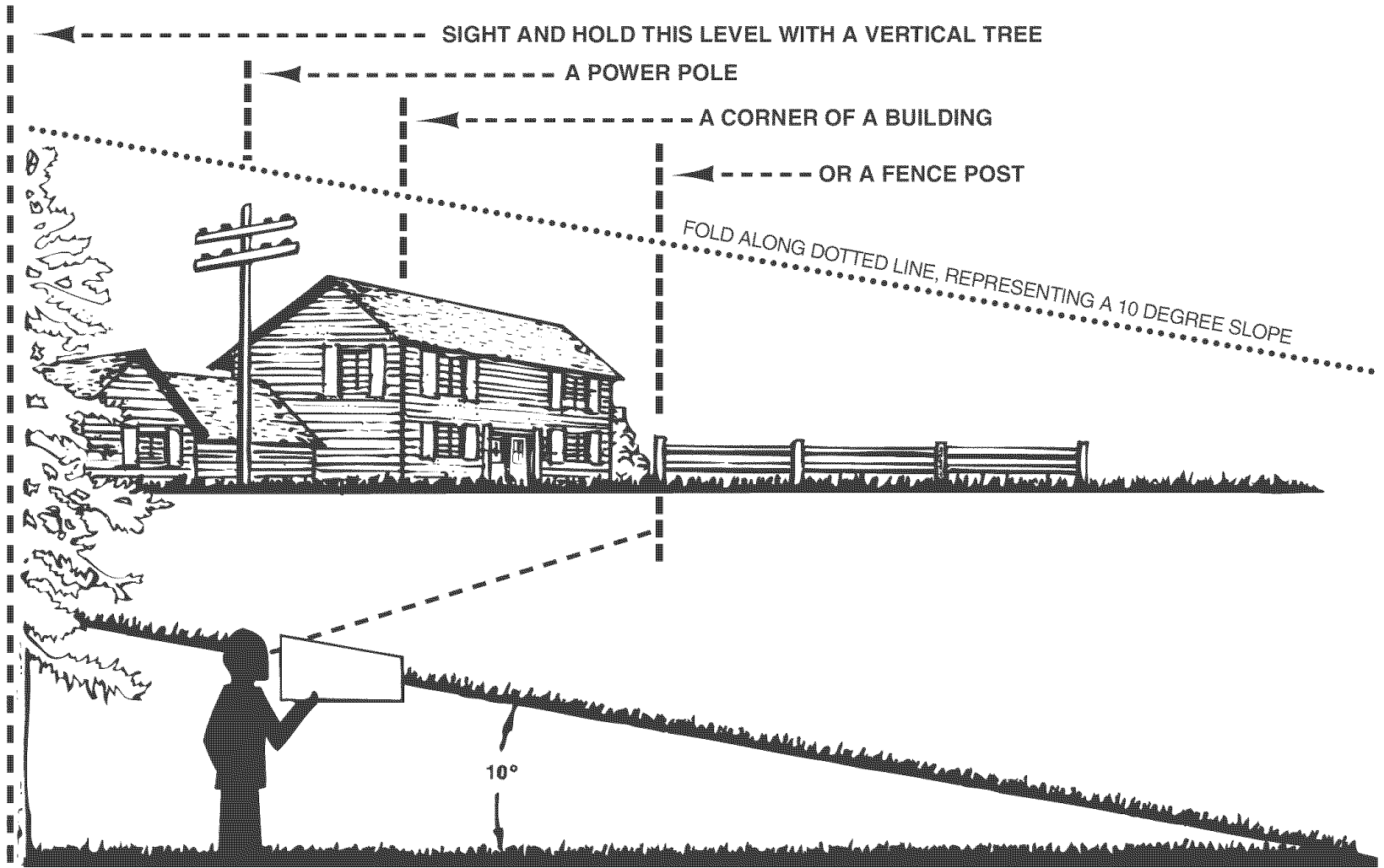

**CAUTION: DO NOT OPERATE YOUR TRACTOR AND TOW BEHIND MOWER ON A SLOPE IN EXCESS OF 10 DEGREES. BE SURE OF YOUR TRACTOR'S TOWING AND BRAKING CAPABILITIES BEFORE OPERATING ON A SLOPE. AVOID ANY SUDDEN TURNS OR MANEUVERS WHILE ON A SLOPE.**

# Get it fixed, at your home or ours!

For repair of major brand appliances **in your own home...**  
no matter who made it, no matter who sold it!

**1-800-4-MY-HOME<sup>SM</sup>** Anytime, day or night  
(1-800-469-4663)

[www.sears.com](http://www.sears.com)

To bring in products such as vacuums, lawn equipment and electronics  
for repair, call for the location of your nearest **Sears Parts & Repair Center.**

**1-800-488-1222** Anytime, day or night

[www.sears.com](http://www.sears.com)

For the replacement parts, accessories and owner's manuals  
that you need to do-it-yourself, call **Sears PartsDirect<sup>SM</sup>!**

**1-800-366-PART** 6 a.m. – 11 p.m. CST,  
(1-800-366-7278) 7 days a week

[www.sears.com/partsdirect](http://www.sears.com/partsdirect)

To purchase or inquire about a Sears Service Agreement:

**1-800-827-6655**

7 a.m. – 5 p.m. CST, Mon. – Sat.

Para pedir servicio de reparación a domicilio,  
y para ordenar piezas con entrega a domicilio:

**1-888-SU-HOGAR<sup>SM</sup>**  
(1-888-784-6427)

Au Canada pour service en français:

**1-877-LE-FOYER<sup>SM</sup>**  
(1-877-533-6937)

