

# Installation Instructions

## NTC6/GNE & NTN6/NNE Upflow/Horizontal Series NDN6/GDE Downflow Series

### SAFETY REQUIREMENTS

Recognize safety information. This is the safety-alert symbol . When you see this symbol on the furnace and in instructions manuals be alert to the potential for personal injury.

Understand the signal words *DANGER*, *WARNING*, or *CAUTION*. These words are used with the safety-alert symbol. *DANGER* identifies the most serious hazards, those that **will** result in severe personal injury or death. *WARNING* signifies a hazard that **could** result in personal injury or death. *CAUTION* is used to identify unsafe practices that **could** result in minor personal injury or product and property damage.

Installing and servicing heating equipment can be hazardous due to gas and electrical components. Only trained and qualified personnel should install, repair, or service heating equipment.

Untrained service personnel can perform basic maintenance functions such as cleaning and replacing air filters. All other operations must be performed by trained service personnel. When working on heating equipment, observe precautions in the literature, on tags, and on labels attached to or shipped with the unit and other safety precautions that may apply.

Follow all safety codes. In the United States, follow all safety codes including the current edition National Fuel Gas Code (NFPA) No. 54/ANSI Z223.1. In Canada, refer to the current edition of the National Standard Canada CAN/CGA-B149.1- and .2-M91 Natural Gas and Propane Installation Codes (NSCNGPIC). Wear safety glasses and work gloves. Have fire extinguisher available during start-up and adjustment procedures and service calls.

These instructions cover minimum requirements and conform to existing national standards and safety codes. In some instances, these instructions exceed certain local codes and ordinances, especially those that may not have kept up with changing residential construction practices. We require these instructions as a minimum for a safe installation.

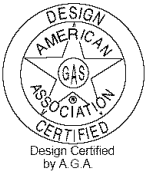

Manufactured by:  
**International Comfort Products Corporation (USA)**  
Lewisburg, TN USA 37091

### Table of Contents

1. Installation .....	2	6. Gas Supply and Piping .....	10
2. Combustion & Ventilation Air .....	5	7. Electrical Wiring .....	12
3. Gas Vent Installation .....	7	8. Ductwork and Filter (Upflow/Horizontal) .....	14
4. Horizontal Venting .....	8	9. Ductwork and Filter (Downflow) .....	15
5. Masonry Chimney Venting .....	9	10. Checks and Adjustments .....	17
		11. Furnace Maintenance .....	18



#### **WARNING**

**Electric Shock Hazard**  
Turn Off All Power Before Servicing.  
Failure to do so can result in death, personal injury and/or property damage.

#### **WARNING**

**Fire or Explosion hazard.**  
This furnace is not designed for use in mobile homes, trailers or recreational vehicles.  
Such use could result in death, bodily injury and/or property damage.

# 1. Installation

## **⚠ WARNING**

**Installation or repairs made by unqualified persons can result in hazards to you and others. Installation MUST conform with local codes or, in the absence of local codes, with codes of all governmental authorities having jurisdiction.**

**The information contained in this manual is intended for use by a qualified service technician who is experienced in such work, who is familiar with all precautions and safety procedures required in such work, and is equipped with the proper tools and test instruments.**

**Failure to carefully read and follow all instructions in this manual can result in furnace malfunction, death, personal injury and/or property damage.**

**NOTE:** This furnace is design certified by the American Gas Association and the Canadian Gas Association for installation in the United States and Canada. Refer to the appropriate codes, along with this manual, for proper installation.

- **This furnace is NOT approved for installation in mobile homes, trailers or recreation vehicles.**
- Do **NOT** use this furnace as a construction heater or to heat a building that is under construction.
- Use only the Type of gas approved for this furnace (see **Rating Plate** on unit). Overfiring will result in failure of heat exchanger and cause dangerous operation. (Furnace can be converted to L.P. gas with approved kit.)
- Do **NOT** use open flame to test for gas leak.
- Ensure adequate combustion and ventilation air is provided to the furnace.
- Seal supply and return air ducts.
- The vent system **MUST** be checked to determine that it is the correct type and size.
- Install correct filter type and size.
- Unit **MUST** be installed so electrical components are protected from direct contact with water.

## Safety Rules

Your unit is built to provide many years of safe and dependable service providing it is properly installed and maintained. However, abuse and/or improper use can shorten the life of the unit and create hazards for you, the owner.

- A. The U.S. Consumer Product Safety Commission recommends that users of gas-burning appliances install carbon monoxide detectors. There can be various sources of carbon monoxide in a building or dwelling. The sources could be gas-fired clothes dryers, gas cooking stoves, water heaters, furnaces, gas-fired fireplaces, wood fireplaces, and several other items. Carbon monoxide can cause serious bodily injury and/or death. Therefore, to help alert people of potentially dangerous carbon monoxide levels, you should have carbon monoxide detectors listed by a nationally recognized agency (e.g. Underwriters Laboratories or International Approval Services) installed and maintained in the building or dwelling (see Note below).
- B. There can be numerous sources of fire or smoke in a building or dwelling. Fire or smoke can cause serious bodily injury, death, and/or property damage. Therefore, in order to alert people of potentially dangerous fire or smoke, you should have fire extinguisher and smoke detectors listed by Underwriters Laboratories installed and maintained in the building or dwelling (see Note below).

**Note:** The manufacturer of your furnace does not test any detectors and makes no representations regarding any brand or type of detector.

- C. To ensure safe and efficient operation of your unit, you should do the the following:
  1. **Thoroughly read this manual and labels on the unit.** This will help you understand how your unit operates and the hazards involved with gas and electricity.
  2. **Do not use this unit if any part has been under water.** Immediately call a qualified service technician to inspect the unit and to replace any part of the control system and any gas control which has been under water.
  3. **Never obstruct the vent grilles, or any ducts that provide air to the unit.** Air must be provided for proper combustion and ventilation of flue gases.  
Carbon monoxide or "CO" is a colorless and odorless gas produced when fuel is not burned completely or when the flame does not receive sufficient oxygen.

## Freezing Temperatures and Your Structure

### **⚠ WARNING**

**Freeze warning.**

**Turn off water system.**

**If your unit remains shut off during cold weather the water pipes could freeze and burst, resulting in serious water damage.**

Your unit is equipped with safety devices that may keep it from operating if sensors detect abnormal conditions such as clogged exhaust flues.

If the structure will be unattended during cold weather you should take these precautions.

1. Turn off main supply water into the structure and drain the water lines if possible. Open faucets in appropriate areas.

- Have someone check the structure frequently during cold weather to make sure it is warm enough to prevent pipes from freezing. Suggest they call a qualified service agency, if required.

## **⚠ WARNING**

**Poison carbon monoxide gas hazard.**

If this furnace is replacing a previously common-vented furnace, it may be necessary to resize the existing vent line and chimney to prevent oversizing problems for the other remaining appliances(s). See applicable codes and *Venting and Combustion Air Check in Gas Vent Installation* section.

Failure to properly vent this furnace or other appliances can result in death, personal injury and/or property damage.

## **Location and Clearances**

If furnace is a replacement, it is usually best to install the furnace where the old one was. Choose the location or evaluate the existing location based upon the minimum clearance and furnace dimensions (Figure 1 and Figure 2).

### **CAUTION**

Do NOT operate furnace in a corrosive atmosphere containing chlorine, fluorine or any other damaging chemicals. Refer to Combustion & Ventilation Air section, Contaminated Combustion Air.

**Figure 1**

**Upflow Dimensions and Clearances (NTC6/GNE & NTN6/NNE)**

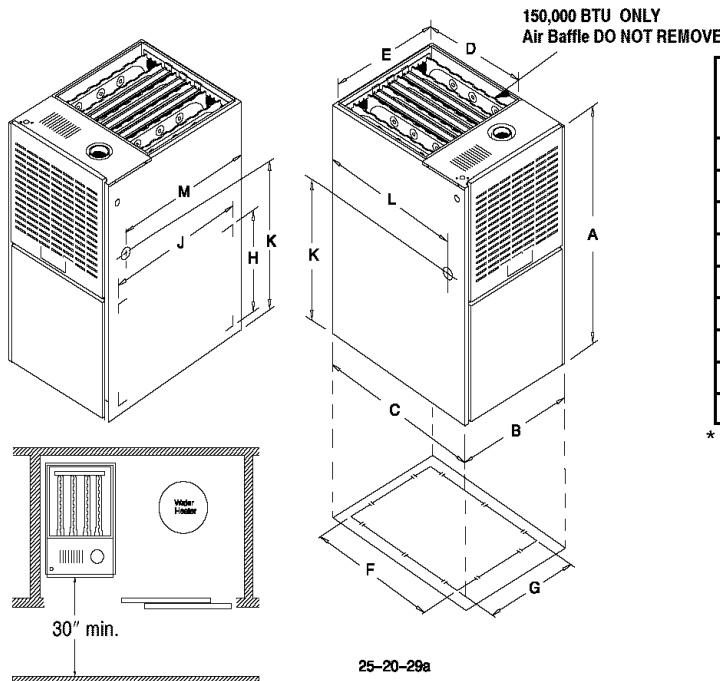

<b>MINIMUM CLEARANCES TO COMBUSTIBLE MATERIALS FOR ALL UNITS</b>	
REAR	0
FRONT	3" (75mm)*
For Service	30" (760mm)
ALL SIDES OF SUPPLY PLENUM	1" (25mm)
SIDES	0
VENT	
Single Wall Vent	6" (150mm)
Type B-1 Double Wall Vent	1" (25mm)
TOP OF FURNACE	6" (150mm)

\* 6" with accessory Masonry Chimney drafthood kit installed.

**ALL DIMENSIONS IN INCHES (millimeters)**

### **DIMENSIONAL INFORMATION**

MODEL	CABINET			SUPPLY AIR		RETURN AIR				GAS CONNECTION		
	A	B	C	D	E	BOTTOM		SIDE		K	L	M
	F	G	H	J								
050FB / 075FB 050B12 / 075B12	40	15 <sup>1</sup> / <sub>2</sub>	28 <sup>1</sup> / <sub>2</sub>	18 <sup>1</sup> / <sub>2</sub>	14	23 <sup>1</sup> / <sub>8</sub>	12 <sup>5</sup> / <sub>8</sub>	12 <sup>1</sup> / <sub>4</sub>	22 <sup>1</sup> / <sub>2</sub>	28 <sup>1</sup> / <sub>4</sub>	26	23 <sup>7</sup> / <sub>8</sub>
075HF & 075F16 100KF / 100F20	40	19 <sup>1</sup> / <sub>8</sub>	28 <sup>1</sup> / <sub>2</sub>	18 <sup>1</sup> / <sub>2</sub>	17 <sup>5</sup> / <sub>8</sub>	23 <sup>1</sup> / <sub>8</sub>	14 <sup>3</sup> / <sub>4</sub>	14 <sup>1</sup> / <sub>2</sub>	22 <sup>1</sup> / <sub>2</sub>	28 <sup>1</sup> / <sub>4</sub>	26	23 <sup>7</sup> / <sub>8</sub>
100KJ / 100J20 125KJ / 125J20 150KJ / 150J20	40	22 <sup>3</sup> / <sub>4</sub>	28 <sup>1</sup> / <sub>2</sub>	18 <sup>1</sup> / <sub>2</sub>	21 <sup>1</sup> / <sub>4</sub>	23 <sup>1</sup> / <sub>8</sub>	18 <sup>3</sup> / <sub>4</sub>	14 <sup>1</sup> / <sub>2</sub>	22 <sup>1</sup> / <sub>2</sub>	28 <sup>1</sup> / <sub>4</sub>	26	23 <sup>7</sup> / <sub>8</sub>
mm Equivalents	40=1016	15 <sup>1</sup> / <sub>2</sub> = 394	19 <sup>1</sup> / <sub>8</sub> = 486	22 <sup>3</sup> / <sub>4</sub> = 578	28 <sup>1</sup> / <sub>2</sub> = 724	18 <sup>1</sup> / <sub>2</sub> = 470	14 = 356	17 <sup>5</sup> / <sub>8</sub> =448				
	21 <sup>1</sup> / <sub>4</sub> = 539	23 <sup>1</sup> / <sub>8</sub> = 587	12 <sup>5</sup> / <sub>8</sub> = 311	14 <sup>3</sup> / <sub>4</sub> = 375	18 <sup>3</sup> / <sub>4</sub> = 476	12 <sup>1</sup> / <sub>4</sub> = 311	14 <sup>1</sup> / <sub>2</sub> = 368	22 <sup>1</sup> / <sub>2</sub> = 572	28 <sup>1</sup> / <sub>4</sub> = 717			
	26 = 660	23 <sup>7</sup> / <sub>8</sub> = 606										

Figure 2

Dimensions and Clearances (NDN6/GDE)

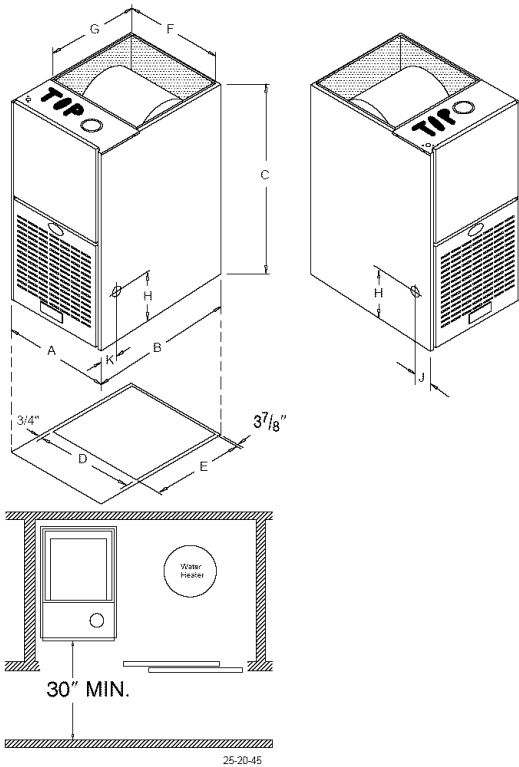

MINIMUM CLEARANCES TO COMBUSTIBLE MATERIALS FOR ALL UNITS	
REAR	0
FRONT	3" (75mm)
For Service	30" (760mm)
ALL SIDES OF SUPPLY PLENUM	1" (25mm)
SIDES	0
VENT	
Single Wall Vent	6" (150mm)
Type B-1 Double Wall Vent	1" (25mm)
TOP OF FURNACE	6" (150mm)

ALL DIMENSIONS IN INCHES (mm)

**DIMENSIONAL INFORMATION**

MODEL	CABINET			BOTTOM OPENING		RETURN OPENING		GAS CONNECTIONS		
	A	B	C	D	E	F	G	H	J	K
NDN6050/075FB GDE050/075B	15 <sup>1</sup> / <sub>2</sub>	28 <sup>1</sup> / <sub>2</sub>	40	14	15 <sup>1</sup> / <sub>2</sub>	14	18 <sup>17</sup> / <sub>32</sub>	9 <sup>13</sup> / <sub>16</sub>	2 <sup>1</sup> / <sub>2</sub>	4 <sup>11</sup> / <sub>16</sub>
NDN6075HF & NDN6100GF/KF GDE075F/100F	19 <sup>1</sup> / <sub>8</sub>	28 <sup>1</sup> / <sub>2</sub>	40	17 <sup>9</sup> / <sub>16</sub>	15 <sup>1</sup> / <sub>2</sub>	17 <sup>9</sup> / <sub>16</sub>	18 <sup>17</sup> / <sub>32</sub>	9 <sup>13</sup> / <sub>16</sub>	2 <sup>1</sup> / <sub>2</sub>	4 <sup>11</sup> / <sub>16</sub>
NDN6125KJ/GDE125J	22 <sup>3</sup> / <sub>4</sub>	28 <sup>1</sup> / <sub>2</sub>	40	21 <sup>3</sup> / <sub>16</sub>	15 <sup>1</sup> / <sub>2</sub>	21 <sup>3</sup> / <sub>16</sub>	18 <sup>17</sup> / <sub>32</sub>	9 <sup>13</sup> / <sub>16</sub>	2 <sup>1</sup> / <sub>2</sub>	4 <sup>11</sup> / <sub>16</sub>
mm Equivalents	15 <sup>1</sup> / <sub>2</sub> = 394	19 <sup>1</sup> / <sub>8</sub> = 486	22 <sup>3</sup> / <sub>4</sub> = 578	28 <sup>1</sup> / <sub>2</sub> = 724	40 = 1016	14 = 356	17 <sup>9</sup> / <sub>16</sub> = 446	17 <sup>9</sup> / <sub>16</sub> = 446	2 <sup>1</sup> / <sub>2</sub> = 64	4 <sup>11</sup> / <sub>16</sub> = 119
	18 <sup>17</sup> / <sub>32</sub> = 471	9 <sup>13</sup> / <sub>16</sub> = 249	2 <sup>1</sup> / <sub>2</sub> = 64	4 <sup>11</sup> / <sub>16</sub> = 119						

**Installation Requirements**

1. Install furnace level.
2. This furnace is **NOT** to be used for temporary heat of buildings or structures under construction.
3. Install the vent pipes as short as practical. (See **Gas Vent Installation** section).
4. Do **NOT** install furnace directly on carpeting, tile or other combustible material other than wood flooring.
5. Maintain clearance for fire safety and servicing. A front clearance of 30" (760mm) is minimum for access to the burner, controls and filter.
6. Use a raised base if the floor is damp or wet at times.
7. Residential garage installations require:
  - Burners and ignition sources installed at least 18" (457mm) above the floor.
  - Furnace must be located or physically protected from possible damage by a vehicle.

**Horizontal Furnace Installation**

**IMPORTANT**

**NOTE:** Inspect unit rating plate to be certain model number begins with "NTC6", "GNE", "NTN6" or "NNE". This identifies unit as horizontally mountable. If unit does **NOT** bear this designation, you may **NOT** mount this unit horizontally. **Horizontal furnace may not be mounted on its back.**

If you purchased a horizontally mountable furnace, it can be installed horizontally in an attic, basement, crawl space, alcove, or suspended from a ceiling in a basement or utility room in either a right or left airflow position. See **Figure 3.**

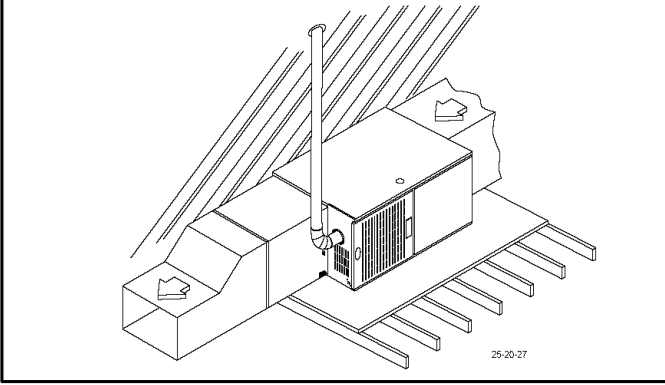
**Figure 3****Typical Horizontal Installation**

The minimum clearances to combustibles **MUST** be maintained between the furnace and adjacent construction. As shown in **Figure 1**, **ONLY** the corner of the cabinet is allowed to contact the rafters **Figure 3**. All other clearances **MUST** be observed as shown in **Figure 1**.

If the furnace is to be suspended from the floor joists in a crawl space or the rafters in an attic, it is necessary to use steel pipe straps or an angle iron frame to attach the furnace. These straps should be attached to the furnace with sheet metal screws and to the rafters or joists with bolts. The preferred method is to use an angle iron frame bolted to the rafters or joists.

If the furnace is to be installed ground level in a crawl space, consult local codes. A concrete pad 1" to 2" (25 to 50mm) thick is recommended.

Thirty inches (30") (760mm) between the front of the furnace and adjacent construction or other appliances **MUST** be maintained for service clearance.

Keep all insulating materials clear from louvered door. Insulating materials may be combustible.

It is recommended for further fire protection that cement board or sheet metal is placed between the furnace and the combustible

wood floor and extend 12" (300mm) beyond the front of the furnace louver door. (This is a recommendation only, not a requirement).

This furnace **MUST NOT** be installed directly on carpeting or tile or other combustible material other than wood flooring or supports.

## Pressure Switch Relocation

If the furnace is installed in a right to left airflow position (left side of furnace facing down), the pressure switch will remain in the same position as installed by the factory (see **Figure 4**). If the furnace is installed in a left to right airflow position (right side of furnace facing down), the pressure switch **MUST** be relocated to the left side of the furnace using the holes provided in the top panel. Position the pressure switch in the same orientation as the original location. To prevent possible kinking of the pressure switch hose, trim the hose to remove excess.

**Note:** Care **MUST** be taken not to cut the tube too short.

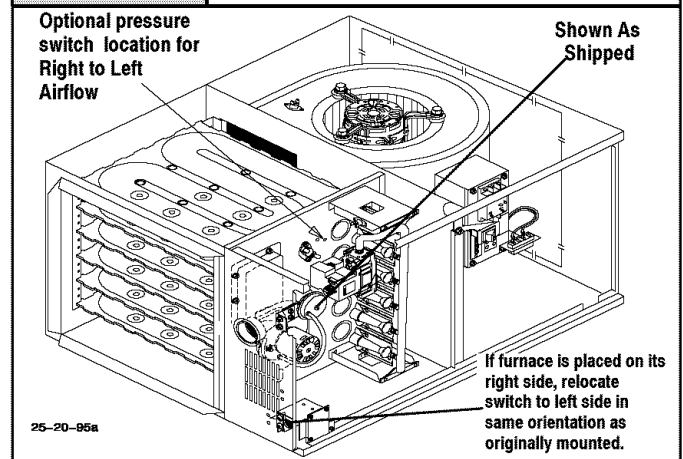
**Figure 4****Pressure Switch Relocation**

## 2. Combustion & Ventilation Air

### **⚠ WARNING**

**Poison carbon monoxide gas hazard.**

**Use methods described here to provide combustion and ventilation air.**

**Failure to provide adequate combustion and ventilation air can result in death and/or personal injury.**

Furnaces require ventilation openings to provide sufficient air for proper combustion and ventilation of flue gases. All duct or openings for supplying combustion and ventilation air must comply with the gas codes, or in the absence of local codes, the applicable national codes.

When the installation is complete, check that all appliances have adequate combustion air and are venting properly. See *Venting And Combustion Air Check* in "Gas Vent Installation" Section in this manual.

## Contaminated Combustion Air

Installations in certain areas or types of structures will increase the exposure to chemicals or halogens that may harm the furnace. These instances must use only outside air for combustion.

The following areas or types of structures may contain or have exposure to the substances listed below. The installation must be evaluated carefully as it may be necessary to provide outside air for combustion.

- Commercial buildings.
- Buildings with indoor pools.
- Furnaces installed in laundry rooms.
- Furnaces installed in hobby or craft rooms.
- Furnaces installed near chemical storage areas.
- Permanent wave solutions for hair.
- Chlorinated waxes and cleaners.
- Chlorine based swimming pool chemicals.
- Water softening chemicals.
- De-icing salts or chemicals.
- Carbon tetrachloride.
- Halogen type refrigerants.

- Cleaning solvents (such as perchloroethylene).
- Printing inks, paint removers, varnishes, etc..
- Hydrochloric acid.
- Sulfuric Acid.
- Solvent cements and glues.
- Antistatic fabric softeners for clothes dryers.
- Masonry acid washing materials.

## Confined Space Installation

**NOTE:** A confined space is defined as an area with less than 50 cubic feet(1.4m<sup>3</sup>) per 1,000 BTUH input rating for all gas appliances installed in the area.

### Requirements

1. Provide confined space with sufficient air for proper combustion and ventilation of flue gases using horizontal or vertical ducts or openings.
2. **Figure 5** illustrates how to provide combustion and ventilation air. A minimum of two permanent openings, one inlet and one outlet, are required.
3. One opening **MUST** be within 12" (300mm) of the floor and the second opening within 12" (300mm) of the ceiling.
4. Size openings and ducts per **Table 1**.
5. Horizontal duct openings require 1 square inch(25sq. mm) of free area per 2,000 BTUH of combined input for all gas appliances in area (see **Table 1**).

6. Vertical duct openings or openings directly to outside require 1 square inch(6.5mm<sup>3</sup>) of free area per 4,000 BTUH for combined input of all gas appliances in area (see **Table 1**).

## Air Openings and Connecting Ducts

1. Total input rating for all gas appliances **MUST** be considered when determining free area of openings.
2. Connect ducts or openings directly to outside.
3. When screens are used to cover openings, the openings **MUST** be no smaller than 1/4" (6mm) mesh.
4. The minimum dimension of rectangular air ducts **MUST NOT** be less than 3" (75mm).
5. When sizing grille or louver, use the free area of opening. If free area is **NOT** stamped or marked on grill or louver, assume a 20% free area for wood and 60% for metal.

One permanent opening, commencing within 12" (30 cm) of the top of the enclosure, shall be permitted where the equipment has clearances of at least 1" (2.5 cm) from the sides and back and 6" (16 cm) from the front of the appliance. The opening shall directly communicate with the outdoors or shall communicate through a vertical or horizontal duct to the outdoors or spaces (crawl or attic) that freely communicate with the outdoors, and shall have a minimum free area of:

- 1 sq. in. per 3000 Btu per hr (7cm<sup>2</sup> per kW) of the total input rating of all equipment located in the enclosure, and
- Not less than the sum of the areas of all vent connectors in the confined space.

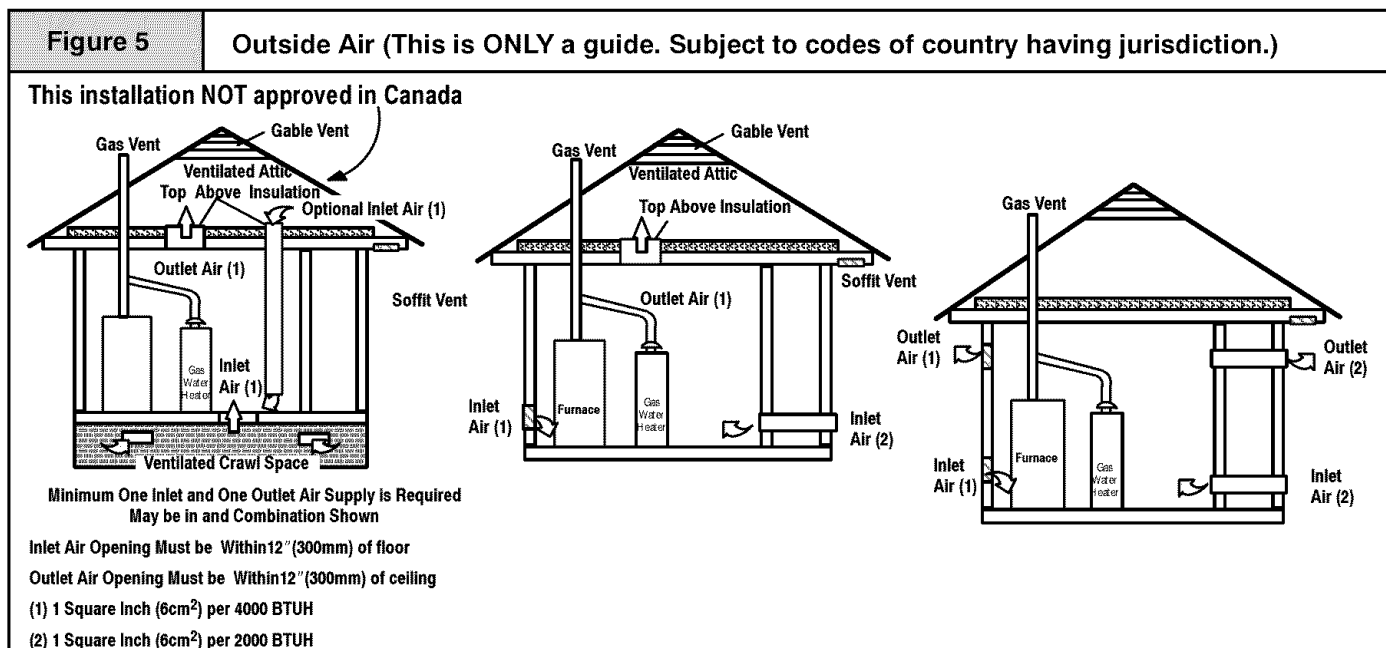

Table 1		Free Area		
BTUH Input Rating	Minimum Free Area Required for Each Opening			
	Horizontal Duct (sq. in./2,000 BTUH)	Vertical Duct or openings to outside (sq. in./4,000 BTUH)	Rd Duct (sq. in./4,000 BTUH)	
50,000	25 sq. in. (161 cm <sup>2</sup> )	12.5 sq. in. (81 cm <sup>2</sup> )	4"	
75,000	35.5 sq. in. (242 cm <sup>2</sup> )	18.75 sq. in. (121 cm <sup>2</sup> )	5"	
100,000	50 sq. in. (323 cm <sup>2</sup> )	25 sq. in. (161 cm <sup>2</sup> )	6"	
125,000	62.5 sq. in. (403 cm <sup>2</sup> )	31.25 sq. in. (202 cm <sup>2</sup> )	7"	

**EXAMPLE: Determining Free Area**  
**Furnace Water Heater Total Input**  
100,000 + 30,000 = (130,000 ÷ 4,000) = 32.5 Sq. In. Vertical (210 cm<sup>2</sup>)  
**Furnace Water Heater Total Input**  
100,000 + 30,000 = (130,000 ÷ 2,000) = 65 Sq. In. Horizontal (419 cm<sup>2</sup>)

## Unconfined Space Installation

**⚠ WARNING**

**Poison carbon monoxide gas hazard.**

**Most homes will require additional air.**

**An unconfined space or homes with tight construction may not have adequate air infiltration for proper combustion and ventilation of flue gases.**

**Failure to supply additional air by means of ventilation grilles or ducts could result in death and/or personal injury.**

## 3. Gas Vent Installation

**⚠ WARNING**

**Poison carbon monoxide gas, fire and explosion hazard.**

**Read and follow all instructions in this section.**

**Failure to properly vent this furnace can result in death, personal injury and/or property damage.**

Install the vent in compliance with codes of the country having jurisdiction, local codes or ordinances and these instructions.

These fan assisted combustion furnaces have been classified as Category I appliances which means that they **MUST** operate with a negative vent pressure.

### Category I Safe Venting Requirements

**NOTE:** The following instructions comply with the United States National Fuel Gas Code. Based on the highest input rate on the furnace rating plate.

1. If a Category I vent passes through an attic, any concealed space or floor, use **ONLY** Type B or Type L double wall vent pipe. If vent pipe passes through interior wall, use type B vent pipe with ventilated thimble **ONLY**.

An unconfined space is defined as an area having a minimum volume of 50 cubic feet (1.4m<sup>3</sup>) per 1,000 Btuh total input rating for all gas appliances in area.

Adjoining rooms can be considered part of an unconfined area if there are no doors between rooms.

An attic or crawl space may be considered an unconfined space provided there are adequate ventilation openings directly to outdoors. Openings **MUST** remain open and **NOT** have any means of being closed off. Ventilation openings to outdoors **MUST** be at least 1 square inch (25mm<sup>2</sup>) of free area per 4,000 BTUH of total input rating for all gas appliances in area.

In unconfined spaces, infiltration should be adequate to provide air for combustion, ventilation and dilution of flue gases. However, in buildings with unusually tight construction, additional air **MUST** be provided using the methods described in section titled *Confined Space Installation*:

Unusually tight construction is defined as: Construction with

1. Walls and ceilings exposed to the outside have a continuous, sealed vapor barrier. Openings are gasketed or sealed and
2. Doors and openable windows are weather stripped and
3. Other openings are caulked or sealed. These include joints around window and door frames, between sole plates and floors, between wall-ceiling joints, between wall panels, at penetrations for plumbing, electrical and gas lines, etc.

### Ventilation Air

Some provincial codes and local municipalities require ventilation or make-up air be brought into the conditioned space as replacement air. Whichever method is used, the mixed return air temperature across the heat exchanger **MUST** not fall below 60°F (15° c) or flue gases will condense in the heat exchanger. This will shorten the life of the heat exchanger and possibly void your warranty.

2. Do **NOT** vent furnace into any chimney serving an open fireplace or solid fuel burning appliance.
3. Use the same diameter Category I connector or pipe as permitted by the **United States National Fuel Gas Code** venting tables.
4. Keep vertical Category I vent pipe or vent connector runs as short and direct as possible.
5. Vertical outdoor runs of type B or **ANY** single wall vent pipe below the roof line are **NOT** permitted.
6. Slope all horizontal runs up away from furnace a minimum of 1/4" (6mm) per foot.
7. Support all horizontal vent pipe every 6' (2m) using proper clamps and metal straps.
8. Check existing gas vent or chimney to ensure they meet clearances and local codes.
9. The furnace **MUST** be connected to a factory built chimney or vent complying with a recognized standard. **Venting into a masonry or concrete chimney is only permitted as outlined in the United States National Fuel Gas Code venting tables or Masonry Chimney section in these instructions.**

## Venting and Combustion Air Check

**NOTE:** If this installation removes an existing furnace from a venting system serving one or more other appliances, and to make sure there is adequate combustion air for all appliances, **MAKE THE FOLLOWING CHECK.**

1. Seal any unused openings in the venting system.
2. Visually inspect the venting system for proper size and horizontal pitch to ensure there is no blockage or restriction, leakage, corrosion or other deficiencies which could cause an unsafe condition.
3. Insofar as is practical, close all doors and windows and all doors between the space in which the appliance(s) remaining connected to the venting system are located and other spaces of the building.
4. Turn on clothes dryers and any appliance not connected to the venting system. Turn on any exhaust fans, such as range hoods and bathroom exhausts, so they will operate at maximum speed. Do not operate a summer exhaust fan. Close fireplace dampers.
5. Follow the lighting instructions for each appliance being inspected. Adjust thermostat so appliance(s) will operate continuously.
6. Allow 5 minutes of main burner operation, then check for spillage at the draft hood relief opening of each appliance. Use the flame of a match or candle (**Figure 6**).

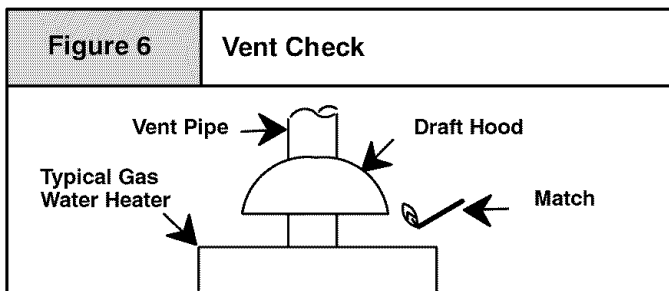

## 4. Horizontal Venting

### Category I Furnaces With External Power Venters

In order to maintain a Category I classification of fan assisted furnaces when vented horizontally with sidewall termination, a power venter is **REQUIRED** to maintain a negative pressure in the venting system. Please consult the Fields Controls Co. or Tjernlund Products, Inc. for power venters certified for use with our furnaces.

7. After it has been determined that each appliance vents properly, return doors, windows, appliances etc. to their normal condition.
8. If improper venting is observed, the cause **MUST** be corrected.

**NOTE:** If flame pulls towards draft hood, this indicates sufficient infiltration air.

### Venting to Existing Masonry Chimney

**NOTE:** The tables and notes referred to below are found in the most recent printing of the **United States National Fuel Gas Code** venting tables.

Use the United States National Fuel Gas Code or NFGC Tables to size the chimney or vent. **Dedicated venting of one fan assisted furnace into any masonry chimney is restricted.** The chimney must first be lined with either type B vent sized in accordance with tables 1 or 2 or a listed single wall, metal lining system, sized in accordance with the vent tables.

Listed, corrugated metallic chimney liner systems in masonry chimneys shall be sized by using **United States National Fuel Gas Code** tables for dedicated venting and **United States National Fuel Gas Code** tables for common venting with the maximum capacity reduced by 20% (0.80 X maximum capacity) and the minimum capacity as shown in the applicable table. Corrugated metal vent systems installed with bends or offsets require additional reduction of 10% of the vent capacity for each 90° elbow.

**NOTE:** Two(2) 45° elbows are equivalent to one (1) 90° elbow.

### Combined Venting into a Masonry Chimney

Venting into a masonry or concrete chimney is **only permitted as outlined in the United States National Fuel Gas Code venting tables.** Follow all safe venting requirements.

### Vent Termination

#### Venting Through a Non-Combustible and Combustible Wall

Consult External Power Venter manufacturer instructions.

#### CAUTION

**It is the responsibility of the installer to properly terminate the vent and provide adequate shielding. This is essential in order to avoid water/ice damage to building, shrubs and walk-ways.**



## 5. Masonry Chimney Venting with Optional Kit (Upflow/Horizontal Furnaces)

### (USA ONLY) Not recommended with downflow furnaces

#### Chimney Inspection

All masonry chimney construction must conform to Standard ANSI/NFPA211 and to any state or local codes applicable. The chimney must be in good condition and a complete investigation must be conducted prior to installation. If the inspection reveals damage or abnormal conditions, make necessary repairs or seek expert help. See "The Chimney Inspection Chart". Measure area of tile-liner and exact height of chimney.

#### Connector Type

To reduce flue gas heat loss and the chance of condensate problems, the vent connector must be double wall Type B vent.

#### Venting Restrictions for Chimney Types

**Interior Chimney** - has no sides exposed to the outside below the roofline. All installations can be single furnace or common vented with another draft hood equipped Category I appliance.

**Exterior Chimney** - has one or more sides exposed to the outside below the roof line. All installations must be common vented only with another draft hood equipped Category I appliance.

**Caution** - failure to follow these guidelines may cause property damage.

#### Optional Masonry Vent Kit Draft Hood Assy. Installation (See Figure 7)

**NOTE:** These instructions apply to the NTC6 & GNE series furnaces only.

1. Disconnect power and gas supply to furnace.
2. Remove louvered door.  
NTC6, GNE, NTN6 & NNE Series furnaces - Discard louvered door.

3. NTC6, GNE, NTN6 & NNE may be installed upflow or horizontal position per furnace application. When installing NTC6, GNE, NTN6 & NNE furnaces in a horizontal left hand application you will need to mount the pressure switch to the side of the cabinet.
4. NTC6, GNE, NTN6 & NNE series furnaces - Detach pressure switch from top panel by removing two screws. Set aside screws.
5. Detach field connect box from top panel by removing two screws. Set aside screws.
6. Remove four screws holding top panel to casing. Remove top panel. Discard top panel. Set screws aside.
7. Install draft hood assy. to casing using four screws previously set aside.
8. Attach field connect box to draft hood assy. using two screws previously set aside.
9. NTC6, GNE, NTN6 & NNE Series furnaces - Attach pressure switch to draft hood assy. using two screws previously set aside.

#### Vent Limit Switch Wiring (See Figure 7)

1. Locate wire harness assy. which is supplied with kit. Attach terminals on one end of wire harness assy. to vent limit switch located on draft hood assy.
2. Locate furnace's main limit. Detach wire with insulated terminal from one side of main limit.
3. Route wire harness assy. from vent limit switch to main limit. Attach female terminal of wire harness assy. to vacated main limit terminal. Attach male terminal of wire harness assy. to insulated terminal of wire previously detached from main limit.

#### Completion of Installation

1. NTC6, GNE, NTN6 & NNE Series furnaces - Locate louvered door supplied with kit. Install on furnace.
2. Refer to installation instructions provided with furnace to put the furnace into operation.

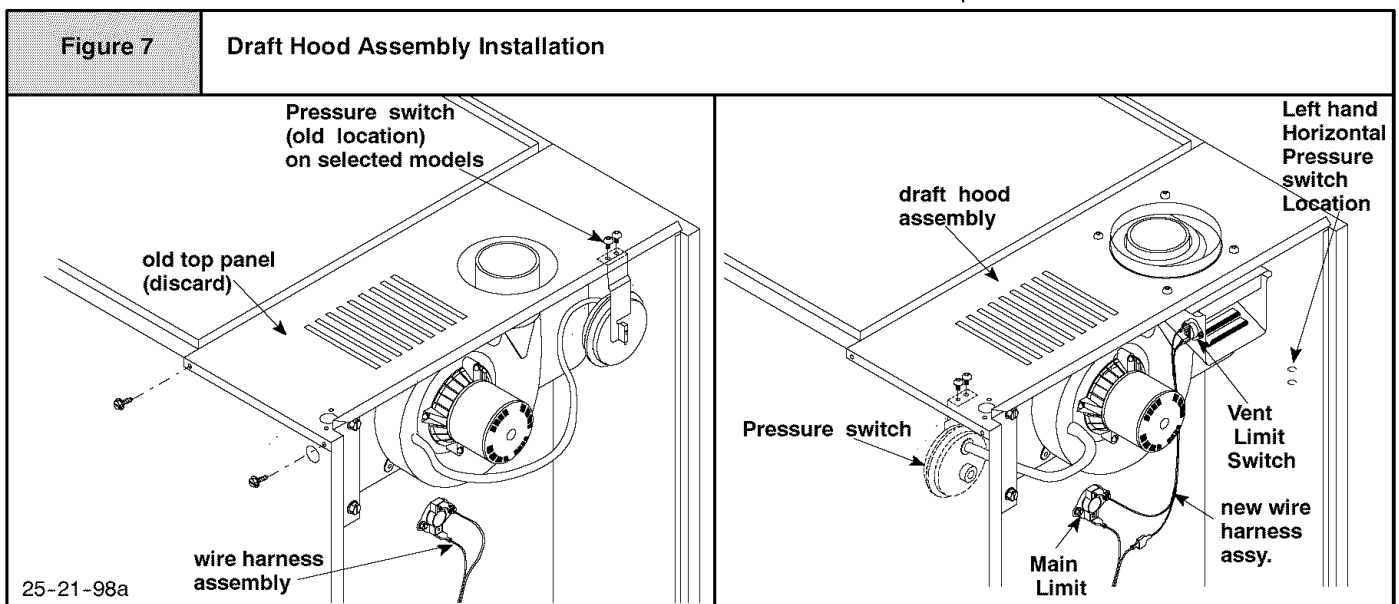

Masonry chimney venting shall be approached as follows: Using **Table 1** and **Table 2** in the masonry chimney draft hood kit instructions, the NFGC Z223.1-1992 or the United States National Fuel Gas Code Venting Tables.

## 6. Gas Supply and Piping

**⚠ WARNING**

Poison carbon monoxide gas, fire and explosion hazard.

Models designated for Natural Gas are to be used with Natural Gas ONLY, unless properly converted to use with LP gas.

Failure to follow these instructions can result in death, personal injury and/or property damage.

### Gas Supply Requirements

- Use only the Type of gas approved for this furnace. See rating plate for approved gas type.
- Gas input must not exceed the rated input shown on the rating plate. Overfiring will result in failure of heat exchanger and cause dangerous operation.
- Do not allow minimum supply pressure to vary downward. Doing so will decrease input to furnace. Refer to **Table 2** for Gas supply and manifold pressures.

Gas Type	Supply Pressure			Manifold Pressure
	Recommended	Max.	Min.	
Natural	7" (1.7 kPa)	14" (3.5 kPa)	4.5" (1.1 kPa)	3.5" (0.9 kPa)
Propane	11" (2.7 kPa)	14" (3.5 kPa)	11" (2.7 kPa)	10" (2.5 kPa)

Gas Type	Manifold Pressure	Specific Gravity	Heating Value (BTU per Cubic Ft.)	Orifice Size (Drill #)
Natural	3.5" w.c. 0.9kPa w.c.	0.6	800	40
			900	41
			1000	42
			1100	43
Propane	10" w.c. 2.5kPa w.c.	1.53	2500	54

### Natural Gas Input Rating Check

The gas meter can be used to measure input to furnace. Rating is based on a natural gas BTU content of 1,000 BTU's per cubic foot. Check with gas supplier for actual BTU content.

- Turn OFF gas supply to all appliances other than furnace and start furnace.
- Time how many seconds it takes the smallest dial on the gas meter to make one complete revolution. Refer to **Example**. **Note:** If meter uses a 2 cubic foot dial, divide results (seconds) by two.

Example			
Natural Gas BTU Content	No. of Seconds Per Hour	Time Per Cubic Foot in Seconds	BTU Per Hour
1,000	3,600	48	75,000
<b>1,000 x 3,600 ÷ 48 = 75,000 BTUH</b>			

- Relight all appliances and ensure all pilots are operating.

### Orifice Sizing

**NOTE:** Factory sized orifices for natural and LP gas are listed in the furnace Technical Support manual.

For downflow ensure furnace is equipped with the correct main burner orifices. Refer to **Table 3** for correct orifice size for a given heating value and specific gravity for natural and propane gas. Note that this chart is **ONLY** for downflow installations *below* 2000' in altitude.

### Operation Above 2000' Altitude

**⚠ WARNING**

Fire, Explosion, Poison carbon monoxide gas hazard.

This conversion shall be done by a qualified service agency in accordance with the Manufacturer's instructions and all applicable codes and requirements, or in the absence of local codes, the applicable national codes.

Failure to follow these instructions exactly can result in death, personal injury and/or property damage.

These units may be used at full input rating when installed at altitudes up to 2000'. When installed above 2000', the input must be decreased 2% (natural) or 4% (LP) for each 1000' above sea level. This may be accomplished by a simple adjustment of manifold pressure or an orifice change, or a combination of a pressure adjustment and an orifice change. The changes required depend on the installation altitude and the heating value of the fuel. **Table 4 & Table 5** show the proper furnace manifold pressure and gas orifice size to achieve proper performance based on elevation above sea level for both natural gas and propane.

To use the natural gas table, first consult your local gas utility for the heating value of the gas supply. Select the heating value on the vertical border and follow across the table until the appropriate elevation for the installation is reached. The first value in the box at the intersection of the heating value and elevation will be the manifold pressure required. If a gas orifice change is also required, the box is shaded. The required orifice size is shown at the bottom of the table.

### Sea Level

**High Altitude Input Rate = Nameplate x (Multiplier)**  
**Input Rate**

Elevation	High Altitude Multiplier	
	Natural	LP Gas
2000' - 2999'	0.96	0.92
3000' - 3999'	0.94	0.88
4000' - 4999'	0.92	0.84
5000' - 5999'	0.90	0.80
6000' - 6999'	0.88	0.76
7000' - 7999'	0.86	0.72

A High Altitude Kit is available for downflow which includes restrictors, orifices and installation instructions.

Natural Gas - 1160993

LP Gas - 1160992

# MANIFOLD PRESSURE AND ORIFICE SIZE FOR HIGH ALTITUDE APPLICATIONS

Table 4	NATURAL GAS						
HEATING VALUE BTU/CU. FT.	MEAN ELEVATION FEET ABOVE SEA LEVEL						
	0 to 1999	2000 to 2999	3000 to 3999	4000 to 4999	5000 to 5999	6000 to 6999	7000 to 8000
800	3.5" wc	3.5" wc	3.5" wc	3.5" wc	3.5" wc	3.5" wc	3.5" wc
850	3.5" wc	3.5" wc	3.5" wc	3.5" wc	3.5" wc	3.5" wc	3.5" wc
900	3.5" wc	3.5" wc	3.5" wc	3.5" wc	3.5" wc	3.5" wc	3.4" wc
950	3.5" wc	3.5" wc	3.5" wc	3.5" wc	3.3" wc	3.2" wc	3.1" wc
1000	3.5" wc	3.4" wc	3.3" wc	3.2" wc	3.0" wc	2.9" wc	2.8" wc
1050	3.2" wc	3.1" wc	3.0" wc	2.9" wc	2.7" wc	2.6" wc	2.5" wc
1100	2.9" wc	2.8" wc	2.7" wc	2.6" wc	2.5" wc	2.4" wc	2.3" wc
Orifice Size	#42	#42	#42	#42	#42	#42	#42

Table 5	LP Gas						
HEATING VALUE BTU/CU. FT.	MEAN ELEVATION FEET ABOVE SEA LEVEL						
	0 to 1999	2000 to 2999	3000 to 3999	4000 to 4999	5000 to 5999	6000 to 6999	7000 to 8000
2500	10.0" wc	10.0" wc	9.4" wc	10.0" wc	9.8" wc	8.8" wc	7.9" wc
Orifice Size	#54	#54	#54	#55	#55	#55	#55

NOTE: NATURAL GAS DATA BASED ON 0.60 SPECIFIC GRAVITY. PROPANE DATA BASED ON 1.53 SPECIFIC GRAVITY. FOR FUELS WITH DIFFERENT SPECIFIC GRAVITY CONSULT THE LATEST EDITION OF THE NATIONAL FUEL GAS CODE ANSI Z223.1 and CAN B149.

## Changing Orifices

- After disconnecting power and gas supply to the furnace, remove the access door, exposing the burner compartment.
  - Remove the five (5) screws holding the burner box cover to expose the manifold and burners. (Figure 8 or Figure 9)
- Disconnect gas line and pilot tubing from gas valve so manifold can be removed.
- Disconnect wiring at gas valve. Be sure to note the proper location of any and all electrical wiring disconnected.
- Remove the four (4) screws holding the manifold and gas valve to the manifold supports. Do not discard any screws. See Figure 8 or Figure 9.

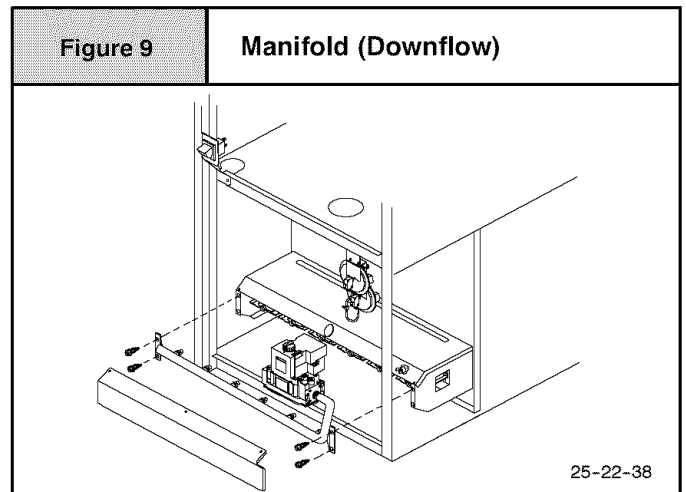
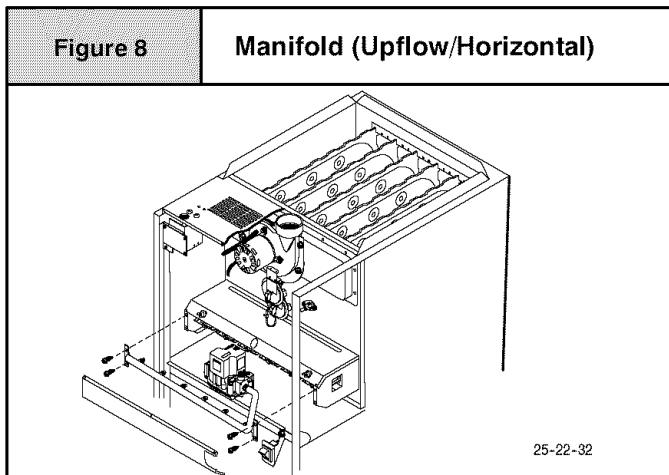

- Carefully remove the manifold assembly.
- Remove the orifices from the manifold and replace them with proper sized orifices. See Figure 10.
- Tighten orifices so it is seated and gas tight.. See Figure 10.

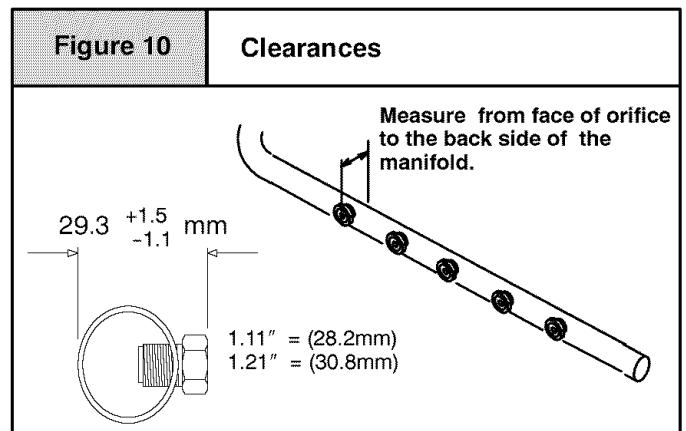

8. Reassemble all parts in reverse order as removed. Be sure to engage the main burner orifices in the proper opening in the burners.
9. After reassembling, turn gas on and check all joints for gas leaks using a soapy solution. All leaks must be repaired immediately.

## Gas Piping Requirements

1. Install gas piping in accordance with local codes, or in the absence of local codes, the applicable national codes.
2. It is recommended that a manual shutoff valve be installed in the gas supply line outside the unit. Locate valve as close to the furnace as possible where it is readily accessible. Refer to Figure 11.

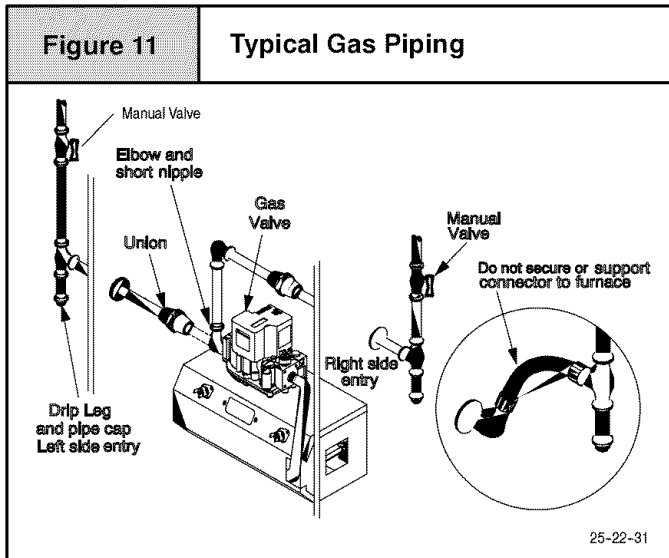

3. Use black iron or steel pipe and fittings or other pipe approved by local code.
4. Use pipe thread compound which is resistant to natural and LP gases.
5. Install a drip leg no less than 3" long to trap dirt and moisture before it can enter gas valve.
6. Provide a  $\frac{1}{8}$ " inch plug for test gauge connection immediately up stream of gas supply connection to furnace.
7. Use two pipe wrenches when making connections to prevent gas valve from turning.
8. Flexible corrugated metal gas connector may **NOT** be used inside the furnace or be secured or supported by the furnace or ductwork.
9. Properly size gas pipe to handle combined appliance load or run gas pipe directly from gas meter or LP gas regulator.
10. Install correct pipe size for run length and furnace rating.
11. Measure pipe length from gas meter or LP second stage regulator.

## 7. Electrical Wiring

### Power Supply Wiring

The furnace **MUST** be electrically wired and grounded in accordance with local codes, or in the absence of local codes, the applicable national codes.

**⚠ WARNING**

**Fire or explosion hazard.**

**The flexible corrugated metal gas connector must be properly installed, cannot go through the side of the furnace, and can not be used inside the furnace.**

**Failure to properly install metal gas connector can result in death, bodily injury and/or property damage.**

### Additional LP Piping Requirements

- Have a licensed LP gas dealer make all connections at storage tank and check all connections from tank to furnace.
- If copper tubing is used, it **MUST** comply with limitation set in Local Codes, or in the absence of local codes, the gas codes of the country having jurisdiction.
- Two-stage regulation of LP gas is recommended.

### Final Check

- Test all pipe for leaks.
- If orifices were changed, make sure they are checked for leaks.
- During pressure testing of gas piping system, observe the following:
  - a. If test pressure does not exceed  $\frac{1}{2}$ " PSIG, isolate the furnace by closing its individual manual shutoff valve.
  - b. If test pressure exceeds  $\frac{1}{2}$ " PSIG, the furnace and its individual shutoff valve must be disconnected from the gas supply system.
- To check for leaks apply soap suds or a liquid detergent to each joint. Bubbles forming indicate a leak.
- Do not use an open flame to test for gas leaks. Fire or explosion could occur.
- Correct even the smallest leak at once.

**⚠ WARNING**

**Fire or explosion hazard.**

**Liquid petroleum (LP) gas is heavier than air and will settle and remain in low areas and open depressions.**

**Thoroughly ventilate area and dissipate gas. Do NOT use a match or open flame to test for leaks, or attempt to start up furnace before thoroughly ventilating area.**

**An open flame or spark can result in death, personal injury and/or property damage.**

Field wiring connections must be made inside the furnace connection box. A suitable strain relief should be used at the point the wires exit the furnace casing.

Copper conductors shall be used. Line voltage wires should be sized for the input amps stated on the rating plate. Furnace must be connected to its own separate circuit.

## Thermostat

Thermostat location has an important effect on the operation of the unit. Follow instructions included with thermostat for correct mounting and wiring.

Low voltage connections to furnace must be made on terminal board to fan control.

If cooling is used, the **Y** from the thermostat must be connected to the control board **Y** to energize cooling blower speed.\*

Set thermostat heat anticipator in accordance with the *Technical Support Manual*.

\*“Y” terminal on thermostat sub-base must be connected to “Y” terminal on furnace fan timer for proper fan speed during operation in air conditioning mode.

## Optional Equipment

All wiring from furnace to optional equipment **MUST** conform to local codes or, in the absence of local codes, the applicable national codes. Install wiring in accordance with manufacturer’s instructions.

## Humidifier/Electronic Air Cleaner

The furnace is wired for humidifier and/or electronic air cleaner connection.

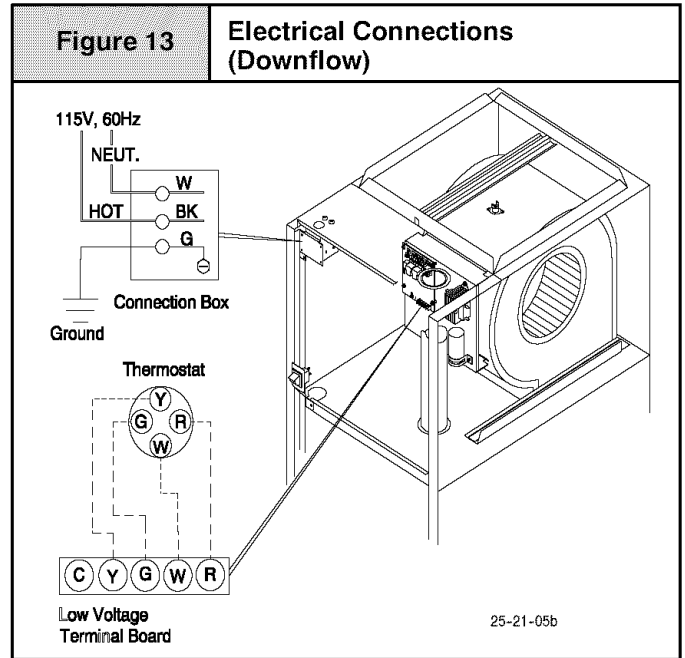

### CAUTION

**Do NOT exceed 115V/0.8 amp. maximum current load for both the EAC terminal and the HUM terminal combined.**

**NOTE:** The humidifier will be powered when the furnace is fired and the circulating air blower comes on. The electronic air cleaner will be powered anytime the thermostat calls for air movement. However, the electronic air cleaner is **NOT** energized during continuous fan operation controlled by the electronic fan control.

## Control Center Fuse

The 24V circuit contains a 5-amp, automotive-type fuse located on control center. (See **Figure 14**) Any electrical shorts of 24V wiring during installation, service, or maintenance may cause fuse to blow. If fuse replacement is required, use only a fuse of identical size (5 amp.)

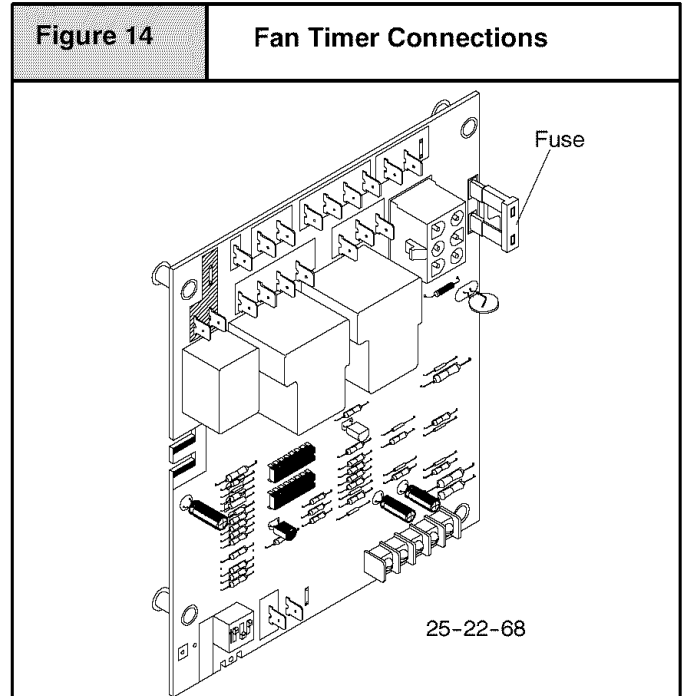
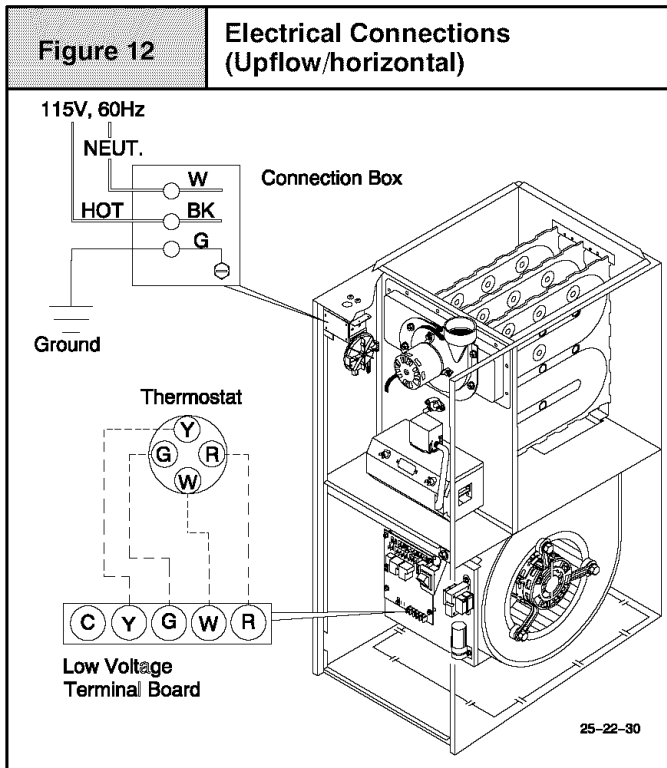

## 8. Ductwork and Filter (Upflow/Horizontal) on NTC6/GNE or NTN6/NNE

### **⚠ WARNING**

Poison carbon monoxide gas hazard.

Do NOT draw return air from inside a closet or utility room where furnace is located. Return air duct MUST be sealed to furnace casing.

Failure to properly seal duct can result in death and/or personal injury.

### Duct Connections

This furnace may be installed in only a bottom or side return application. Return air through the back of the unit is **NOT** allowed.

Side connections can be made by cutting out the embossed area shown in **Figure 15**.

Bottom returns can be made by removing the knockout panel in the furnace base. Do **NOT** remove knock-out except for a bottom return.

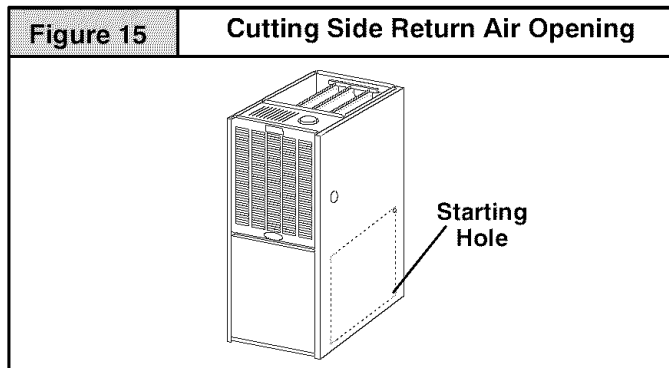

### Duct Design

Design and install air distribution system to comply with Air Conditioning Contractors of America manuals or other approved methods that conform to local codes and good trade practices.

When the furnace is located in an area near or adjacent to the living area, the system should be carefully designed with returns to minimize noise transmission through the return air grille. Any blower moving a high volume of air will produce audible noise which could be objectionable when the unit is located very close to a living area. It is often advisable to route the return air ducts under the floor or through the attic.

- Refer to furnace **Technical Support Manual** (Blower Data) for air flow information.
- Size ductwork to handle air flow for heating and air conditioning if used.

### Duct Installation Requirements

- When furnace supply ducts carry air outside furnace area, seal return air duct to furnace casing and terminate duct outside furnace space.

- When a refrigeration coil is used in conjunction with this unit, it must be installed on the discharge side of the unit to avoid condensation on the heat exchanger.
- Installation of locking-type dampers are recommended in all branches, or in individual ducts to balance system's air flow.
- If air return grille is located close to the fan inlet, install at least one, 90° air turn between fan and inlet grille to reduce noise.
- Ductwork installed in attic, or exposed to outside temperatures requires a minimum of 2" of insulation with outdoor type vapor barrier.
- Ductwork installed in an indoor unconditioned space requires a minimum of 1" of insulation with indoor type vapor barrier.

### Inspection Panel

A removable access panel should be provided in the outlet duct when the furnace is installed without a cooling coil. This will allow smoke or reflected light to be observable inside the casing to indicate the presence of leaks in the heat exchanger. This access cover shall be attached in such a manner as to prevent air leaks.

### Filters

A filter **MUST** be used:

Filters are not supplied with these furnaces, but can be purchased from your dealer.

Use either filter type:

- Washable, high velocity filters are based on a maximum air flow rating of 600 FPM.
- Disposable, low velocity filters are based on a maximum air flow of 300 FPM when used with filter grille.
- The furnaces, with 1600 or less CFM rating use a 16" x 25" high velocity filter. On these models the filter may be mounted internally for bottom return using factory kit or externally for side return.
- The furnaces with greater than 1600 CFM requires that both left and right side returns are used in side return applications. Filters must be mounted externally. If return air must be on one side only, an optional 20" x 25" filter standoff rack kit can be used. For bottom return an optional 20" x 25" filter rack kit can be used.

**NOTE:** The 20 x 25" standoff filter rack gives more filter area but does not provide more air. To achieve 2000 CFM a bottom return or 2 side returns are still needed.

**NOTE:** Disposable, low velocity filters may be replaced with washable, high velocity filter providing they meet the minimum size areas. Washable, high velocity filters can be replaced **ONLY** with same type and size.

# 9. Ductwork and Filter (Downflow) on NDN6/GDE

## Sub-Bases for Combustible Floors - Furnace Only

The Subbase for Combustible Floors **MUST** be used when a downflow furnace is set on combustible material even when the furnace is installed on a coil box (cased coil).

**NOTE:** Supply opening is  $3\frac{7}{8}$ " from the rear of the furnace. Therefore maintain a  $3\frac{7}{8}$ " clearance from a wall behind the furnace (where applicable).

1. Cut the opening in the floor according to **Table 6**. The hole in the floor must be cut to the dimensions listed in **Table 6** since the base is equipped with locating tabs that center the base over the opening.

The opening in the base is  $1\frac{1}{4}$ " (32mm) shorter and  $1\frac{1}{8}$ " (29mm) narrower than the minimum required size of the opening in the floor. This is done to maintain a 1" clearance between the floor and the plenum.

2. Fabricate the plenum to the dimensions given in **Table 6**. Note that the dimensions given are outside dimensions.

Table 6 Sub-bases for Combustible Floors Dimensions										
sub-base for Combustible Floors Part Number	sub-base for Combustible Floor Dimensions				Opening In Floor		Opening In Base For Plenum		Typical Plenum Dimensions	
	H*	J*	K**	L	M	N	P	R	S	T
<b>(Furnace Only)</b>										
NAHH001SB	$15\frac{11}{16}$	$28\frac{3}{4}$	$14\frac{9}{16}$	16	$16\frac{1}{4}$	$14\frac{5}{8}$	15	$13\frac{1}{2}$	15	$13\frac{1}{2}$
NAHH002SB	$19\frac{5}{16}$	$28\frac{3}{4}$	$18\frac{3}{16}$	16	$16\frac{1}{4}$	$18\frac{1}{4}$	15	$17\frac{1}{8}$	15	$17\frac{1}{8}$
NAHH003SB	$22\frac{15}{16}$	$28\frac{3}{4}$	$21\frac{13}{16}$	16	$16\frac{1}{4}$	$21\frac{7}{8}$	15	$19\frac{3}{4}$	15	$19\frac{3}{4}$
<b>sub-base for Cased Coil</b>										
NAHH004SB	$15\frac{11}{16}$	$20\frac{9}{16}$	$14\frac{9}{16}$	16	$16\frac{1}{4}$	$14\frac{5}{8}$	15	$13\frac{1}{2}$	15	$13\frac{1}{2}$
NAHH005SB	$19\frac{5}{16}$	$20\frac{9}{16}$	$18\frac{3}{16}$	16	$16\frac{1}{4}$	$18\frac{1}{4}$	15	$17\frac{1}{8}$	15	$17\frac{1}{8}$
NAHH006SB	$22\frac{15}{16}$	$20\frac{9}{16}$	$21\frac{13}{16}$	16	$16\frac{1}{4}$	$21\frac{7}{8}$	15	$19\frac{3}{4}$	15	$19\frac{3}{4}$
<b>Equivalents in mm</b>	$15\frac{11}{16} = 398$ $19\frac{5}{16} = 491$ $22\frac{15}{16} = 583$	$28\frac{3}{4} = 730$ $20\frac{9}{16} = 522$	$14\frac{9}{16} = 370$ $18\frac{3}{16} = 462$ $21\frac{13}{16} = 554$	16 = 406	$16\frac{1}{4} = 412$	$14\frac{5}{8} = 371$ $18\frac{1}{4} = 464$ $21\frac{7}{8} = 556$	15 = 381	$13\frac{1}{2} = 343$ $17\frac{1}{8} = 435$ $19\frac{3}{4} = 502$	15 = 381	$13\frac{1}{2} = 343$ $17\frac{1}{8} = 435$ $19\frac{3}{4} = 502$
* Outside Dimension										
** Base Spacer Side To Side										

3. Set the base over the opening in the floor, centering the opening in the base over the opening in the floor. Fasten the base to the floor with screws or nails. See **Figure 16** and **Figure 18**.
4. Drop the plenum through the opening in the base. The flange of the plenum should rest on top of the combustible floor base.

## Sub-base for Combustible Floors- Downflow Coil Box

The Subbase for Combustible Floors **MUST** be used when a downflow furnace, **used with a downflow coil box**, is set on combustible flooring.

**NOTE:** Supply opening is  $3\frac{7}{8}$ " from the rear of the furnace. Therefore maintain a  $3\frac{7}{8}$ " clearance from wall (where applicable).

1. Cut the opening in the floor according to **Table 6**. The hole in the floor must be cut to the dimensions listed in **Table 6** since the base is equipped with locating tabs that center the base over the opening.

The opening in the base is  $1\frac{1}{4}$ " (32mm) shorter and  $1\frac{1}{8}$ " (29mm) narrower than the recommended size of the opening in the floor. This is done to provide a 1" clearance between the floor and the plenum.

2. Fabricate the plenum to the dimensions given in **Table 6**. Note that the dimensions given are outside dimensions.
3. Set the base over the opening in the floor, centering the opening in the base over the opening in the floor. Fasten the base to the floor with screws or nails. See **Figure 17** and **Figure 18**.
4. Drop the plenum through the opening in the base. The flange of the plenum should rest on top of the combustible floor base.

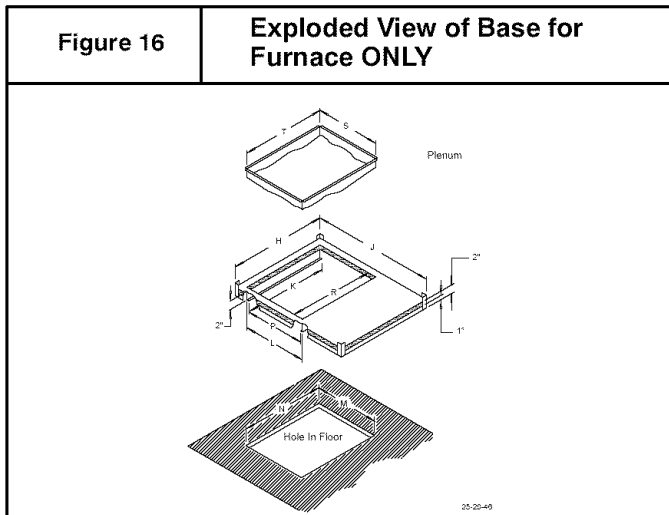

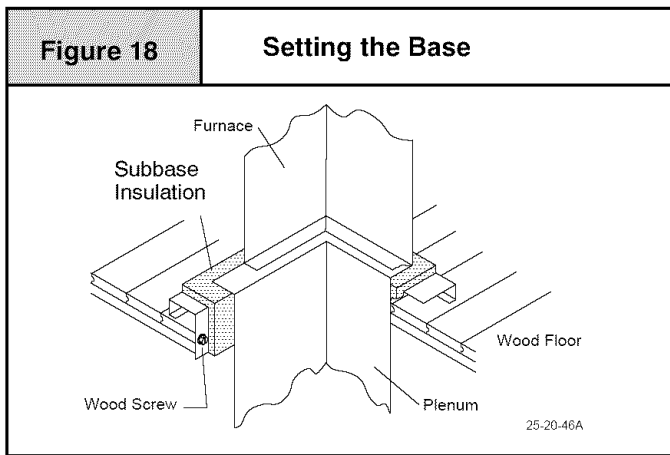
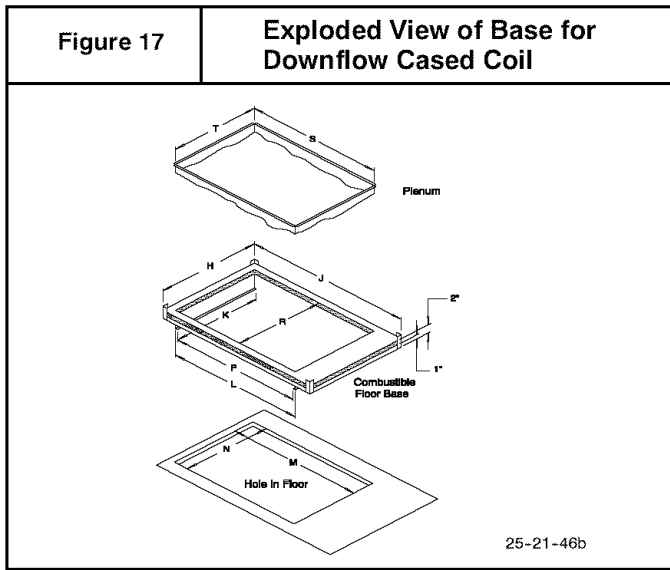

This subbase for combustible floors has been designed so that the height of the sub-base raises the downflow coil off the floor to allow easy installation of the condensate drain. See **Figure 19**.

**Non-Combustible Floor:**

Set the furnace over the opening in the floor. If necessary, grout around the base to seal air leaks between the base and the floor.

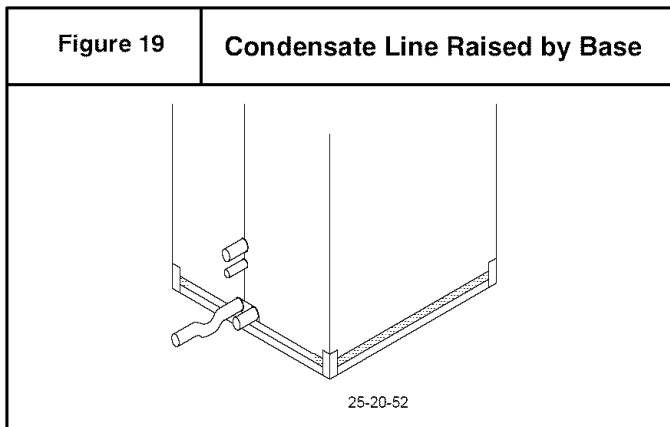

**Filters:**

The filters supplied with the furnace may be installed in the return air plenum above the furnace. A filter rack is supplied with each downflow furnace. See **Figure 20** and **Figure 21**.

**NOTE:** The furnace is provided with high velocity type filter(s). The size, quantity, and type of filter supplied with the furnace will handle the airflow required if central air conditioning is used with the furnace.

**NOTE:** The return air plenum **MUST** extend a sufficient height above dimension "A" (**Figure 21**) to provide for the attachment of a return air duct or grille above the filters.

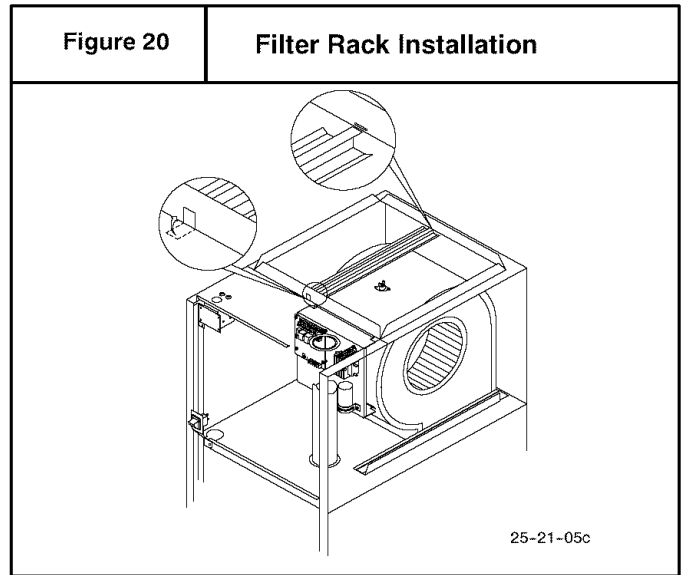

1. Insert end of filter rack with  $\frac{3}{4}$ " (19mm) flange into slot in the back of the unit. See **Figure 20**.
2. With filter rack pushed back, insert front end with  $\frac{1}{4}$ " (6mm) flange into position and push into front slot. With filter rack pushed as far forward as it will go, bend  $\frac{1}{4}$ " (6mm) flange and  $\frac{3}{4}$ " (19mm) flange up 90 degrees. See **Figure 20**.

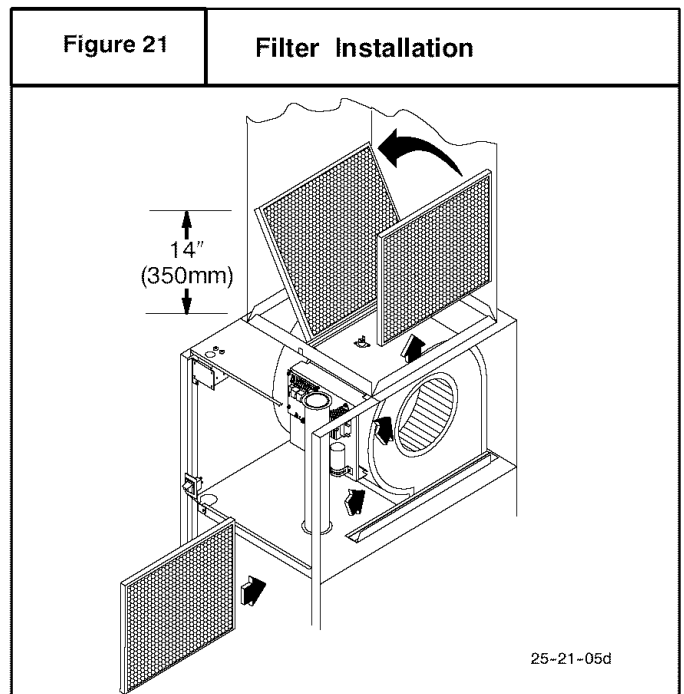

**NOTE:** Plenum must be fitted as close to the return air flange of the unit as possible to eliminate any air bypassing the filters.



- Filters can only be installed through the right hand side of the unit blower opening. Slide filter into unit until it is in position to be pushed up and over into place on the left hand side of unit. See **Figure 21**.
- Slide remaining filter into unit and up into place on left hand side of unit. See **Figure 21**.

If there is insufficient plenum height for this type of installation, filters may be installed in any accessible location in the return air system. In such a case, the filters should be of equivalent size and style as originally supplied with the furnace.

## 10. Checks and Adjustments

### Startup

**NOTE:** Refer to startup procedures in the *Users Information Manual*.

#### CAUTION

If any sparks, odors or unusual noises occur, immediately shut OFF power to furnace. Check for wiring errors or obstruction to blower.

### Gas Supply Pressure

Gas supply pressure should be within minimum and maximum values listed on rating plate. Pressures are usually set by gas suppliers.

(See L.P. Kit instruction manual for furnaces converted to L.P. gas)

### Manifold Gas Pressure Adjustment

**NOTE:** Make adjustment to manifold pressure with burners operating.

**⚠ WARNING**

**Fire or explosion hazard.**  
**Turn OFF gas at shut off before connecting manometer.**  
**Failure to turn OFF gas at shut off before connecting manometer can result in death and/or personal injury.**

- With gas **OFF**, Connect manometer to gas valve or manifold tap. Use manometer with a 0 to min. 12" water column range.
- Turn gas **ON** and remove adjustment screw cover on gas valve. Turn counterclockwise to decrease pressure and clockwise to increase.

**NOTE:** Adjustment screw cover **MUST** be placed on gas valve before reading manifold pressure and operating furnace.

- For altitudes up to 2000', set pressure to value shown in **Table 2**. For altitudes between 2000' to 8000', see Section 6. "Gas Supply and Piping" for correct pressure value.

### Adjust Pilot Burner

The furnace has a pilot flame to light the main burner. The flame should surround  $\frac{3}{8}$ " to  $\frac{1}{2}$ " of the flame rod. See **Figure 22**. To adjust, remove cap from pilot adjusting screw on gas valve. Turn screw counterclockwise to increase or clockwise to decrease flame as required. Replace cap after adjusting screw.

### Filter Removal

- Remove compartment door.
- Reach up above right side of blower and lift dirty filters out of rack at top of furnace.
- Straighten up filters and pull straight down at side of blower. Pull out through right door opening.
- Vacuum clean or wash with warm water and dry thoroughly before replacing.

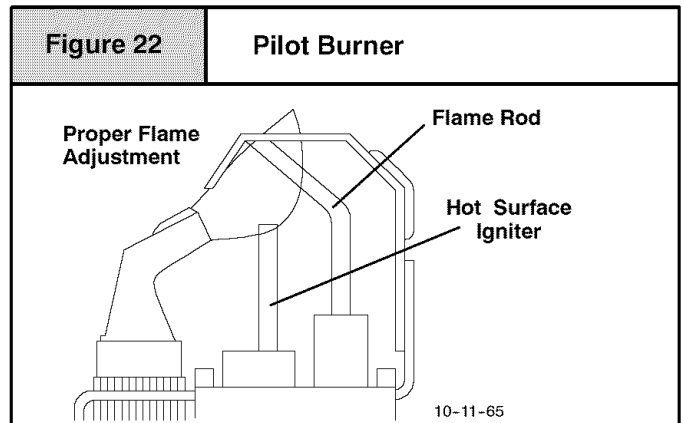

### Main Burner Flame Check

Allow the furnace to run approximately 10 minutes then inspect the main burner and pilot flames. See **Figure 23**.

Check for the following (**Figure 23**):

- Stable and blue flames. Dust may cause orange tips or wisps of yellow, but flames **MUST NOT** have solid, yellow tips.
- Flames extending directly from burner into heat exchanger.
- Flames do **NOT** touch sides of heat exchanger

If any problems with main burner flames are noted, it may be necessary to adjust gas pressures, or check for drafts.

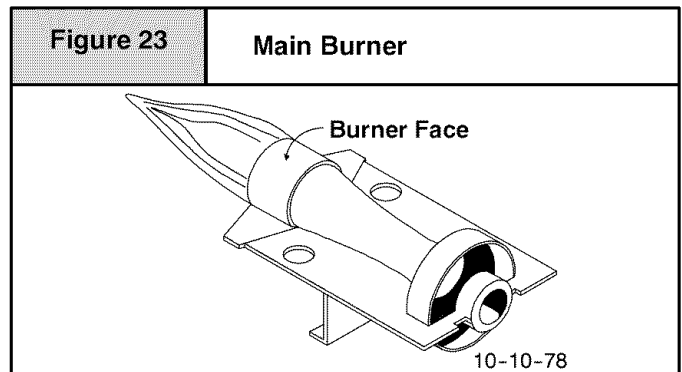

### Temperature Rise Check

The blower speed **MUST** be set to give the correct air temperature rise through the furnace as marked on the rating plate. Temperature rise is the difference between supply and return air temperatures.

To check temperature rise, use the following procedure:

- Place thermometers in supply and return air registers as close to furnace as possible, avoiding direct radiant heat from heat exchangers.
- Take readings and compare with range specified on rating plate.
- If the temperature rise is not in the correct range, the blower speed must be changed. A higher blower speed will lower the temperature rise. A lower blower speed will increase the temperature rise.

## Changing Blower Speed

**⚠ WARNING**

**Electrical shock hazard.**  
**Turn OFF power to furnace before changing speed taps.**  
**Failure to do so can result in death, personal injury and/or property damage.**

**NOTE:** Wiring diagram may not reflect actual factory settings. Installer/contractor must choose proper speed taps for individual applications.

**Since the manufacturer cannot establish the static pressure that will be applied to the unit, it is the responsibility of the installer dealer/contractor to select the proper speed taps for the application when the unit is installed.**

If it is necessary to change speeds, refer to steps below.

- Refer to *Furnace Wiring Diagram* for location of the heating and cooling speed taps located on the electronic fan control as well as location of unused blower motor speed leads. Use the chart (Table 7) to determine the blower motor speed settings.

Table 7 Blower Speed Chart	
Wire Color	Motor Speed
Black	High
Orange*	Med-High
Blue	Medium
Red	Low

\* Med-High speed may not be provided on all models.

## Continuous Fan Operation

A terminal is provided on the electronic fan control located in the circulating blower compartment for operation of the continuous fan option. This connection is intended for the low speed motor tap, and has a lower contact rating (8 amps) than the heat and cool taps. When the low speed blower lead is connected to this terminal, this will provide low speed blower operation whenever the other two speeds (**Heat** or **Cool**) are not energized.

Thoroughly check the system after modification to ensure the proper operation of the circulating air blower in all modes of operation.

## Separate speed selections for Heat, Cool, and Continuous Fan

Connect low speed lead from circulating motor to the "**Cont**" terminal at the electronic fan control. The appropriate motor leads should already be connected to the "**Heat**" and "**Cool**" terminals.

## Heating and Continuous Blower Speed the Same

If it is necessary to operate the heating speed and continuous blower speed using the same blower speed, connect a jumper between the "**Heat**" and "**Cont**" terminals on the electronic fan control.

**Note:** There should be only **ONE** motor lead going to the "**Heat**" and "**Cont**" terminals.

## 11. Furnace Maintenance

### CAUTION

It is recommended that the furnace be inspected and serviced on an annual basis (before the heating season) by a qualified service technician.

See "*User's Information Manual*".