

User's Information Manual

Gas Furnaces

90+ Four Position Furnaces
N9MP1, N9MP2, *9MPD, *9MPT & *9MPV

80+ Single Stage Furnaces
80+ 2-Stage & Variable Speed Furnaces

! WARNING

Fire or explosion hazard.

Information in this manual **MUST** be followed exactly.

Failure to follow the information in this manual exactly could result in death, bodily injury and/or property damage.

- Do not store or use gasoline or other flammable vapors and liquids in the vicinity of this or any other appliance.
- **WHAT TO DO IF YOU SMELL GAS**
 - Do **NOT** try to light any appliance.
 - Do **NOT** touch any electrical switch; do **NOT** use any phone in your building.
 - Immediately evacuate the building and call your gas supplier from a phone outside the building. Follow the gas supplier's instructions.
 - If you cannot reach your gas supplier, call the fire department.
- Installation and service must be performed by a qualified installer, service agency or the gas supplier.

Manufactured by:

International Comfort Products Corporation (USA)
Lewisburg, TN USA 37091

Contents

Danger, Warning and Caution	2	Operating Your Unit	5
Safety Rules	3	Unit Maintenance	6
Combustion Air (Your safety)	4	Warranty	11

Danger, Warning and Caution

The signal words **DANGER**, **WARNING** and **CAUTION** are used to identify levels of hazard seriousness. The signal word **DANGER** is only used on product labels to signify an immediate hazard. The signal words **WARNING** and **CAUTION** will be used on product labels and throughout this manual and other manuals that may apply to the product.

Signal Words

DANGER - Immediate hazards which **WILL** result in severe personal injury or death.

WARNING - Hazards or unsafe practices which **COULD** result in severe personal injury or death.

CAUTION - Hazards or unsafe practices which **COULD** result in minor personal injury or product or property damage.

Signal Words in Manuals

The signal word **WARNING** is used throughout this manual in the following manner:



The signal word **CAUTION** is used throughout this manual in the following manner:

CAUTION

Product Labeling

Signal words are used in combination with colors and/or pictures on product labels. Following are examples of product labels with explanations of the colors used.

Danger Label

White lettering on a black background except the word **DANGER** which is white with a red background.



Warning Label

White lettering on a black background except the word **WARNING** which is black with an orange background.



Caution Label

White lettering on a black background except the word **CAUTION** which is black with a yellow background.

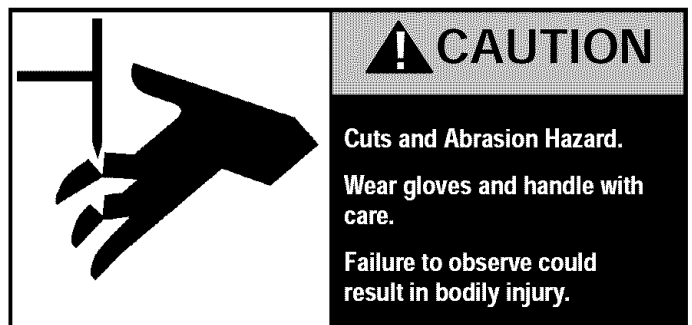

WARNING

Read this manual and follow its instructions and adhere to all Cautions and Warnings in the manual and on the unit.

Consult a qualified service technician for installation, adjustment and maintenance.

Failure to observe and follow Cautions, Warnings and instructions may result in death, bodily injury or property damage.

Safety Rules

Your unit is built to provide many years of safe and dependable service providing it is properly installed and maintained. However, abuse and/or improper use can shorten the life of the unit and create hazards for you, the owner.

- A. The U.S. Consumer Product Safety Commission recommends that users of gas-burning appliances install carbon monoxide detectors. There can be various sources of carbon monoxide in a building or dwelling. The sources could be gas-fired clothes dryers, gas cooking stoves, water heaters, furnaces, gas-fired fireplaces, wood fireplaces, and several other items. Carbon monoxide can cause serious bodily injury and/or death. Therefore, to help alert people of potentially dangerous carbon monoxide levels, you should have carbon monoxide detectors listed by a nationally recognized agency (e.g. Underwriters Laboratories or International Approval Services) installed and maintained in the building or dwelling (see Note below).
- B. There can be numerous sources of fire or smoke in a building or dwelling. Fire or smoke can cause serious bodily injury, death, and/or property damage. Therefore, in order to alert people of potentially dangerous fire or smoke, you should have fire and smoke detectors listed by Underwriters Laboratories installed and maintained in the building or dwelling (see Note below).

Note: The manufacturer of your furnace does not test any detectors and makes no representations regarding any brand or type of detector.

- C. To ensure safe and efficient operation of your unit, you should do the the following:
 1. **Thoroughly read this manual and labels on the unit.** This will help you understand how your unit operates and the hazards involved with gas and electricity.
 2. **Do not use this unit if any part has been under water.** Immediately call a qualified service technician to inspect the unit and to replace any part of the control system and any gas control which has been under water.
 3. **Never obstruct the vent grilles, or any ducts that provide air to the unit.** Air must be provided for proper combustion and ventilation of flue gases.
 4. **Familiarize yourself with the possible air starvation signals.** These are outlined in the Combustion Air section.
 5. **Check the combustion air supply.** Some models use air drawn from outside, See **Figure 3**. Other models and other appliances use combustion air from inside the structure. Air starvation signals are given on this page. If any of the signals are noticed, perform a combustion air check as shown on page 4 or call a service technician. If you add weather stripping, storm windows, insulation, an additional fuel burning appliance, or remodel the structure, a combustion air check **MUST** be accomplished after the addition

6. **Maintain safety and service clearances from the unit.** These are listed on Unit Clearance Label on the cabinet. Keep the unit area clean and free of combustible materials at all times. Never store gasoline, paint, aerosol cans, waxes, bleaches, dry cleaning fluid or items such as paper or rags near the unit.
7. **Examine the furnace area when the furnace or additional insulation is added since some insulation materials may be combustible.** Furnace must be kept free and clear of exposed or loose insulation materials in the area of installation.
8. **Check the return air duct connection.** The duct connection must be physically sound, sealed to the furnace casing and must terminate outside the space containing the furnace.
9. **Familiarize yourself with all controls.** Make sure you know how to shut off the gas and the electrical power to the unit. If the unit is to be shut down for an extended length of time (example; remodeling project), turn off both the gas and the electrical power. For safety, always turn them off before performing service or maintenance on the unit.
10. **Establish a regular service and maintenance schedule.** This will ensure efficient and safe operation of the unit. It is recommended that you have a qualified service agency perform a complete check on the unit before each heating season. See unit Maintenance "Service Technician Checks". Combustion Air (Your Safety)

Combustion Air (Your Safety)

WARNING

All fuel-burning appliances must be provided with enough fresh air for proper combustion and ventilation of flue gases.

Some models use air from the space in which they are located, and other appliances in the same space may also be using indoor air for ventilation and/or combustion.

Lack of combustion air will result in carbon monoxide gas which could cause death or serious bodily injury.

New materials and methods are being used in construction and remodeling which result in lower energy costs for heating and cooling. It may also mean your appliances may not be getting enough air for combustion and ventilation of flue gases. The use of exhaust fans, fireplaces, clothes dryers, and other appliances consume air or vent it outside.

If the appliances or heating unit can't get enough air, two conditions may result:

1. The appliance or heating unit may produce carbon monoxide gas.
Carbon monoxide or "CO" is a colorless and odorless gas produced when fuel is not burned completely or when the flame does not receive sufficient oxygen.
2. The appliance may not vent flue gases properly.

The following are signs that your appliances may not be getting enough air for proper combustion.

Be aware of these signals;

1. **Headaches-Nausea-Dizziness**
2. **Excessive humidity-heavily frosted windows or a moist "clammy" feeling in the structure.**

- Smoke from the fireplace won't draw up the chimney.

⚠ WARNING

If you experience headaches, nausea, or dizziness, carbon monoxide may be present. Leave the house immediately and call your gas supplier. Carbon monoxide poisoning can result in death from asphyxiation or serious bodily injury.

Combustion Air Checks

If any of the signals are noticed, perform a combustion air check or call a service technician. If you add weather stripping, storm windows, insulation, an additional fuel burning appliance, or remodel the structure, a combustion air check **MUST** be accomplished after the addition.

Make the inspection as follows:

- Close all doors and windows. If you have a fireplace, start a fire and wait until flames are burning vigorously.
- Turn on all exhausting devices, such as: kitchen and bathroom exhaust fans and dryers (gas or electric).
- Turn on all vented gas appliances, such as: heating equipment (includes any room heaters) and water heaters.
- Wait ten (10) minutes for drafts to stabilize.
- On appliances with a draft hood, check for spillage by holding a lighted match 2 inches from the draft hood opening. Reference **Figure 1** which shows a water heater draft hood.

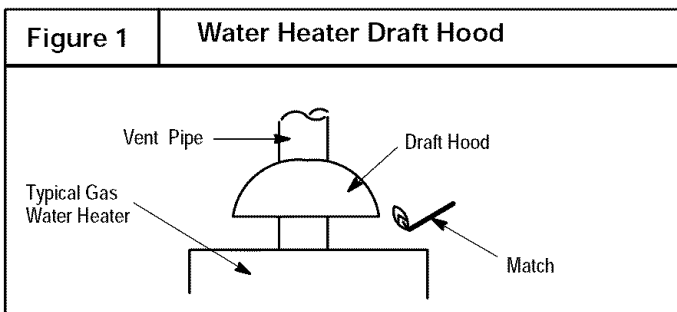

- Match flame pulls toward draft hood.* This indicates no spillage and that appliance is getting enough air for combustion. Return exhausting devices and appliances to the condition you found them.
- Match goes out or flame wavers away from draft hood.* This indicates spillage and that appliance is not getting enough air for combustion.

⚠ WARNING

Draft hood spillage means there is not enough air for proper combustion and carbon monoxide may be present. Keep a window open (a minimum of 2") near the appliance until a permanent air duct is installed. Contact a qualified service agency. Carbon monoxide poisoning can result in death from asphyxiation or serious bodily injury.

If draft hood spillage is indicated:

- Check for plugged flue connectors and chimneys. Repair stoppage and test again.
- If you have a fireplace, open a window or door near the fireplace and then check for spillage. If spillage stops, do not use the fireplace until you can supply fresh air by a permanent duct.
- If you have kitchen and bathroom exhaust fans, turn them **OFF** and check for spillage. If spillage stops, do not use exhaust fans until you can supply fresh air by a permanent duct. Circuit breakers for fans should be turned off.
- Spillage means air starvation and a fresh air duct or air intakes must be installed to provide air directly to the area around the unit. These **MUST** comply with local and state building codes or in their absence with the National Fuel Gas Code NFPA 54 ANSI Z223.1, current edition or in Canada the National Standard CAN/CGA 1-B149.

Indoor Humidity (Your Comfort)

Relative humidity is important to your health. Proper humidification helps cut down incidences of respiratory illness. Air that is too wet may damage the building structure. Air that is too dry is uncomfortable. A quick way to test for proper humidity is as follows:

- Look for frequent fogging or excessive condensation on the inside of windows. This indicates the indoor humidity level is too high for outdoor weather conditions.
- Drop three ice cubes into a glass of water and stir. If, within three minutes, moisture does not form on the glass, the air is too dry and a humidifier would be beneficial. (Do not perform this test in the kitchen, cooking vapors may produce inaccurate results.)

A good relative humidity is one just high enough to barely start condensation along the lower edges or lower corners of the windows, when it is cold outside. More than that can be damaging.

If the humidity is too high, try these suggestions to lower the humidity:

- Reduce setting or discontinue use of humidifier.
- Use range and bathroom exhaust fans while cooking and bathing. Open a door or window for a few minutes to bring in cool drier air.
- Cook with pans covered.
- Take shorter baths or showers with cooler water.
- Install a fresh air intake duct. Cold, dry air brought in from outside to the unit area lowers the indoor humidity level.
- Have appliances checked. A malfunctioning appliance can contribute water vapor to the structure.
- If the problem continues, consult a heating contractor about adding a heat recovery ventilator or air to air heat exchanger.

About Your Unit

Figure 2 shows the location of the components in the unit.

Circulating Air Blower

The blower circulates room air through the unit, air ducts, and into the rooms of the structure. The blower can be set at the thermostat for automatic or manual operation. In manual mode the blower operates continuously. In automatic, the blower does not come on until a preset time after the gas valve is energized. When the structure reaches the temperature set on the thermostat, the unit will shut off. The blower will continue to run until the unit cools down.

Thermostat

There are many types and styles of thermostats. Most thermostats control both heating and cooling functions and have a Fan Switch with **AUTO** and **ON** settings. On **AUTO**, the Circulating Air Blower will cycle on/off with the unit, on the heating speed unless a call for cooling is initiated. Blower speed will correspond to the mode of operation of the unit. If the Fan Switch is positioned to **ON** the blower will run continuously.

In addition some thermostats are programmable with multiple set backs. The set backs can be pre-programmed to lower or raise the temperature automatically.

Be sure to become familiar with your thermostat.

Rating Plate

The rating plate contains important information for the service technician and lists the complete model, manufacturing and serial numbers. You should always provide all these numbers when requesting parts or if you need service. See **Figure 2** or **Figure 3** for rating plate location.

Door Interlock Switch

All the electrical power for the unit goes through the door interlock switch. The interlock switch interrupts electrical power to the unit when the blower door is removed. The unit will not operate until the blower door is reinstalled.

Fan Control

The fan/delay control provides power to the circulating air blower to keep it on until the unit cools down.

The fan off setting can be adjusted if the fan remains on long enough that cool drafts are felt in the room after the furnace shuts off.

The delay is set by moving a set of switches on the control. The Wiring Diagram located on the inside of the blower door shows the various delay combinations. Refer to **Figure 2** or **Figure 3** for location of the control.

If you are unsure how to set the Fan Control, contact a Qualified Service Technician.

Electronic Ignition Module/Gas Valve

When the thermostat calls for heat it completes a circuit to the electronic ignition module. The module sends an electrical signal which ignites the pilot, then opens the gas valve.

When the flame is firmly established the ignitor goes off. If there is a malfunction, the gas valve automatically shuts off the gas.

Pressure Switch

The unit is equipped with two pressure switches to shut down the unit under various flue conditions. The switches are connected to the furnace by factory supplied tubing.

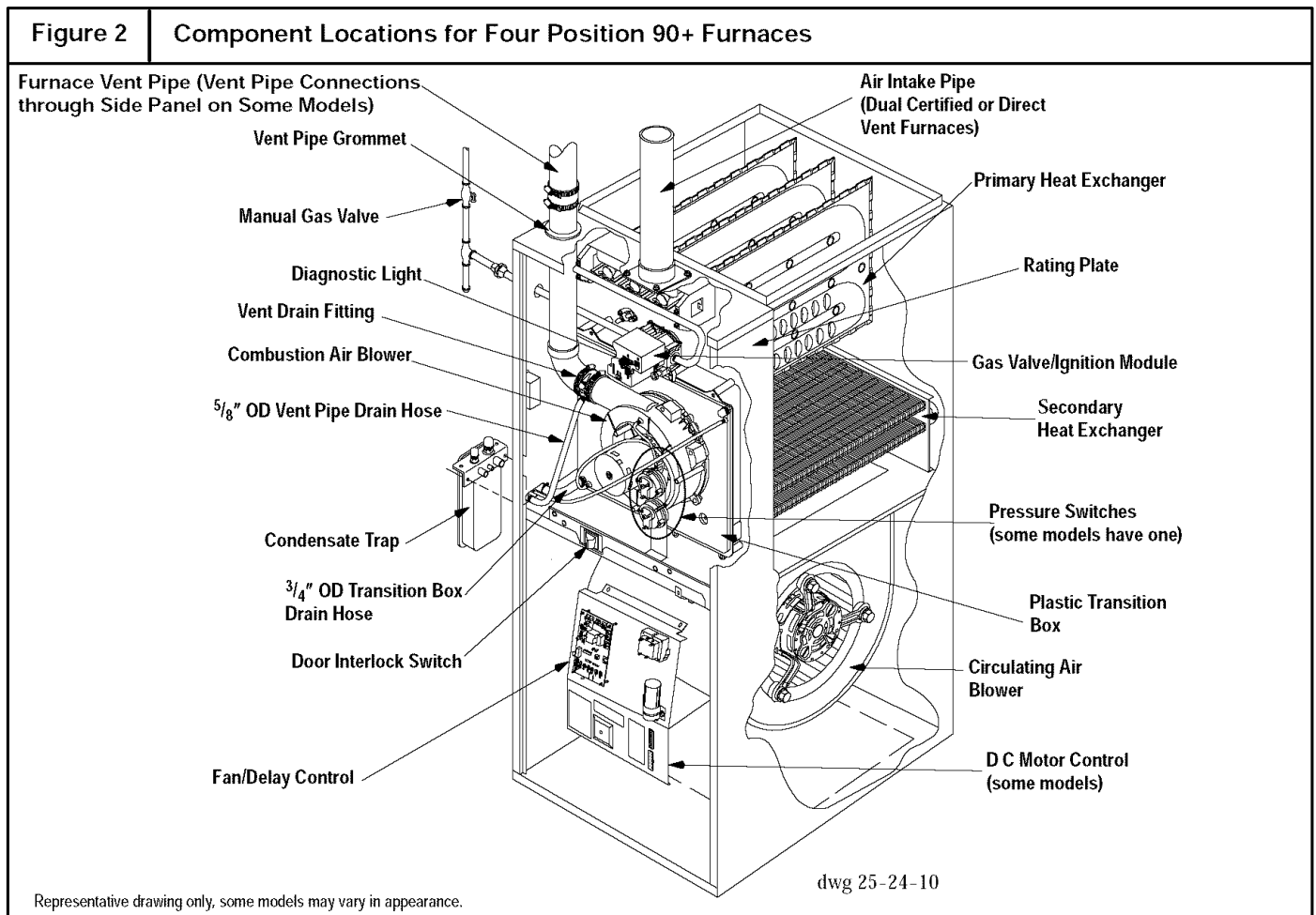
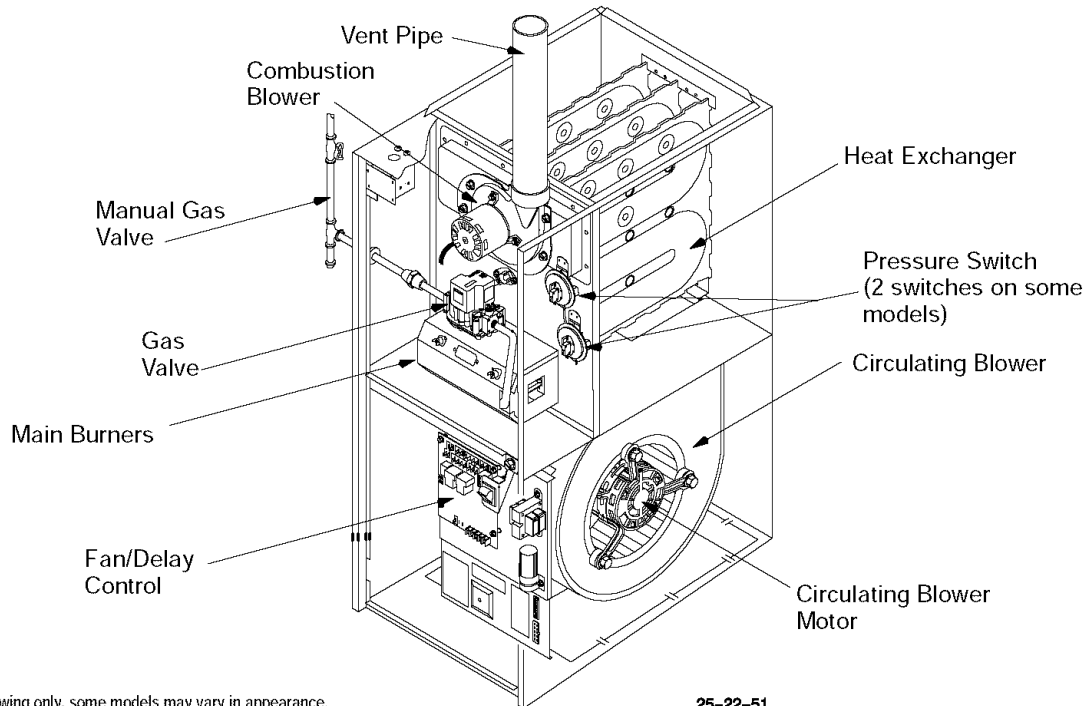

Figure 3 Component Locations for 80+ Furnaces



Representative drawing only, some models may vary in appearance.

25-22-51

Operating Your Unit

Keep the blower access door and all access panels in place except for inspection or maintenance.

Before starting your unit be sure you read and understand all of the procedures in this manual. Check to make sure the unit filter is clean and correctly installed.

! WARNING

Carbon monoxide Poisoning Hazard.

Provisions for combustion and ventilation air must be provided for in accordance with installation instructions supplied with unit.

Failure to provide adequate combustion and ventilation air can result in death and/or personal injury.

Starting The Unit

See Figure 4 for an illustration of the gas valve.

1. Turn the thermostat to its lowest temperature setting or to **OFF** if equipped with a System Select Switch.
2. Turn **OFF** all electric power to the unit at the disconnect switch or circuit breaker.
3. Remove the louvered access panel in front of the unit by lifting the panel up and outwards. Removing the panel will expose the gas control switch.
4. Slide the gas control switch to **OFF**. See Figure 4.
5. Wait five (5) minutes to clear out any gas. If you then smell gas, **STOP!** Follow the safety information on the cover of this manual. If you do not smell gas, go to the next step.

6. Slide the control switch to **ON**.
7. Reinstall all access panels.
8. Turn **ON** all electrical power to the unit.
9. Set the thermostat to the desired temperature and the System Select Switch to **HEAT**.

The unit will activate an ignitor which lights the pilot flame. When the pilot lights and verifies a steady flame, the ignition system brings on the main burners.

System Retries

The ignition system tries to relight the burners whenever the built-in flame sensor detects no flame.

Turning Off The unit

Set the thermostat to the lowest setting or set System Select Switch to **OFF** if equipped.

Should overheating occur or the gas supply fail to shut off, shut off the manual gas valve to the unit before shutting off the electrical supply.

Extended Shutdown

1. Set thermostat to lowest setting or set System Select Switch to **OFF** if equipped.
2. Slide the gas valve control switch to **OFF**.
3. Turn Manual Shutoff Valve to **OFF** position, (at right angle or 90° to gas line).
4. Turn electric power off. (May be left **ON** for set-back type thermostat with batteries, provided thermostat has a system select switch to place in the **OFF** position.)

Figure 4 Typical Gas Valve Honeywell Gas Furnaces

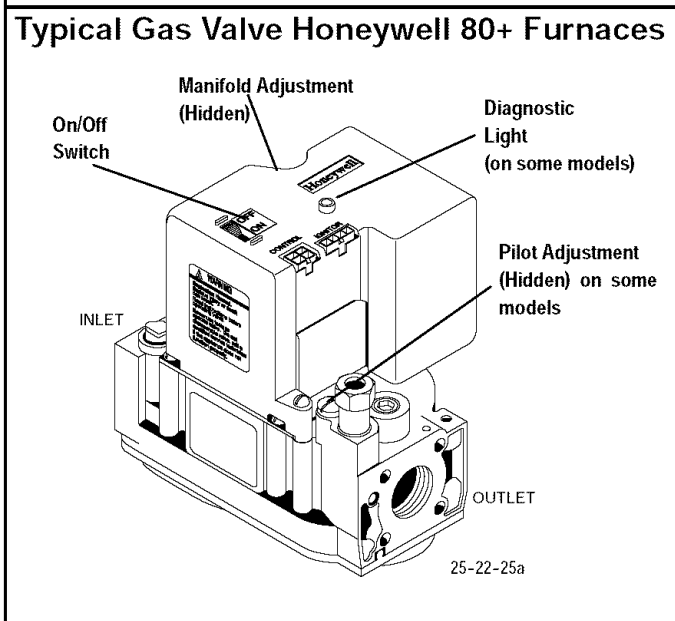
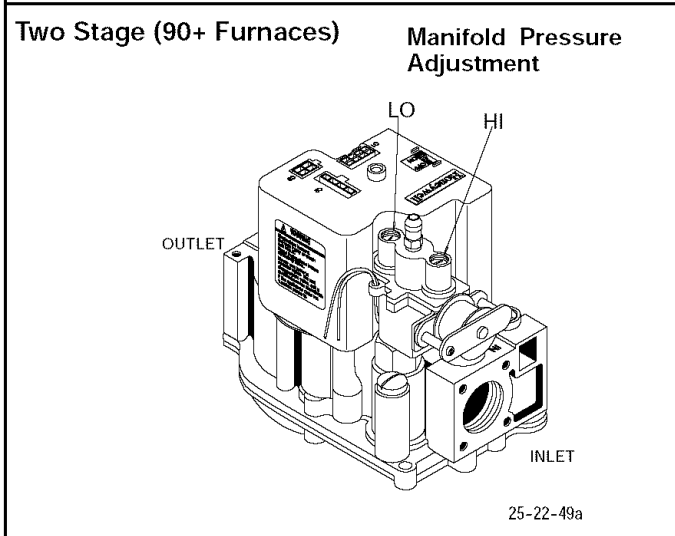
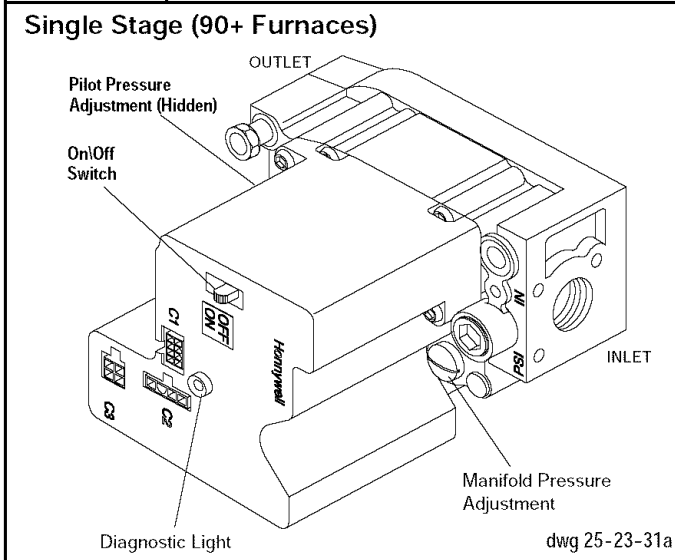

L P Model Units

If your L.P. (liquefied petroleum) gas unit is installed in an excavated or low lying area, we recommend that you contact your L.P. supplier about installing a warning device that would alert you of a gas leak.

⚠ WARNING

Fire or explosion hazard.
 L.P. gas is heavier than air. Leaking gas can settle in low areas such as a crawl space. If you suspect the presence of gas, follow the instructions on the cover of this manual.
 Failure to observe could result in death, bodily injury or property damage.

Freezing Temperatures And Your Structure

⚠ WARNING

Freeze warning.
 Turn off water system.
 If your unit remains shut off during cold weather the water pipes could freeze and burst, resulting in serious water damage.

Your unit is equipped with safety devices that may keep it from operating if sensors detect abnormal conditions such as clogged exhaust flues.

If your unit remains shut off during cold weather the water pipes could freeze and burst, resulting in serious water damage.

If the structure will be unattended during cold weather you should take these precautions.

1. Turn off main supply water into the structure and drain the water lines if possible. Open faucets in appropriate areas.
2. Have someone check the structure frequently during cold weather to make sure it is warm enough to prevent pipes from freezing. Suggest they call qualified service agency, if required.

Winter Shutdown (90+ Furnaces)

1. Disconnect the $\frac{5}{8}$ " OD rubber hose from the vent drain fitting that is located downstream of the combustion blower. Insert a funnel into the hose and pour four (4) ounces of sanitary type (RV) antifreeze into the condensate trap. Reconnect the $\frac{5}{8}$ " OD rubber hose to the stub on the vent drain fitting. Secure with the hose clamp.
2. Disconnect the $\frac{3}{4}$ " OD rubber hose from the condensate trap. Insert a funnel into the hose and pour four (4) ounces of sanitary type (RV) antifreeze into the plastic transition box. Squeeze the hose together near the end and quickly reconnect the $\frac{3}{4}$ " OD rubber hose to the stub on the condensate trap. Secure with the hose clamp.

When you return home, your furnace will be ready to start, as it is not necessary to drain the antifreeze from the furnace.

Unit Maintenance

Have your unit inspected and serviced on an annual basis (before the heating season) by a qualified service technician.

Labeling

CAUTION

Label all wires prior to disconnection when servicing controls. Wiring errors can cause improper and dangerous operation.

Verify proper operation after servicing.

Pressure Switches

During regular yearly maintenance check for cracks in any tubes on the pressure switches.

<p>⚠ WARNING</p>
<p>Electric shock hazard. Turn off electrical power to unit before performing any maintenance or removing panels or doors. Failure to observe could result in death or bodily injury.</p>

Air Filters/ Monthly

The air filter(s) should be inspected at least monthly and cleaned or replaced as required. There are two types of filters that are commonly used. The most widely used is the Fiberglass disposable type which should be **REPLACED** before it becomes clogged. The other type is the washable type constructed of aluminum mesh, foam, or reinforced fibers. Washable filters may be cleaned by soaking in mild detergent and rinsing with water.

Remember that dirty filters are the most common cause of inadequate heating or cooling performance.

<p>⚠ WARNING</p>
<p>Fire hazard from dust and lint buildup on internal unit parts. Never operate unit without a filter installed. Failure to observe could result in death or bodily injury.</p>

Replacement Filters

Table 1 lists recommended sizes and types of filters that may be used with your unit, based on the input rating and Btuh.

Replacement filters should be of the same type and size as the originals, to ensure adequate air flow and filtering. A disposable low velocity filter can be replaced with a washable high velocity type. Do not replace a high velocity filter with a disposable low velocity filter.

Filter Replacement (Optional Filter Rack) - Upflow

The filter rack may be installed in the bottom of the blower compartment, or on the outside on either side of the unit. A plastic end cap is inserted in the filter rack after the filter is installed. The end cap keeps air from escaping around the open end of the filter rack. See **Figure 5** and **Figure 7** for locations.

Filter racks attached to the unit are made so the filter simply slides out one side for removal.

1. Turn off electric power to furnace.
2. Remove the end cap from the filter rack.
3. Slide the filter out of the filter rack.
4. Inspect the filter(s) and replace or clean washable types. If filter is aluminum mesh it should be recoated with filter coating spray.
5. Reinstall the end cap in the filter rack.
6. Turn furnace on.

Filter Replacement - Bottom Mounted

1. Turn off power to furnace.
2. Remove blower door.
3. Slide filter straight out toward you.
4. Inspect the filter(s) and replace or clean washable types. If filter is aluminum mesh it should be recoated with filter coating spray.
5. Replace blower door.
6. Turn on electric power to furnace.

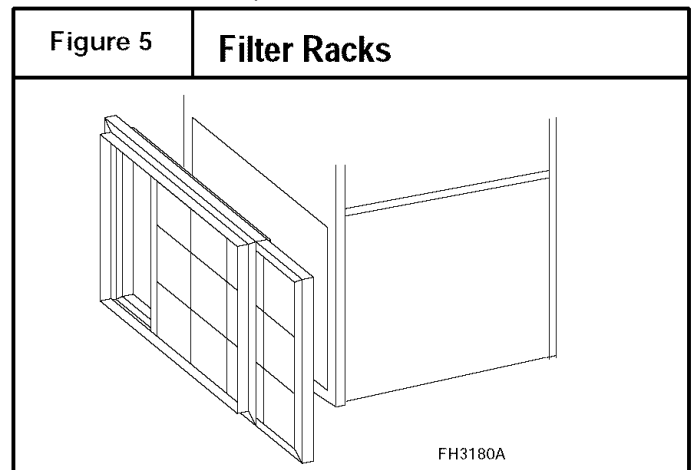

Filter Replacement -- Counterflow

A filter rack is supplied with all downflow models, however filters are not supplied with all models. (see to **Figure 6**) Refer to note for proper size. The filter rack is installed in the top of the counterflow unit from the right side. To remove filter, refer to **Figure 6** for the following steps.

NOTE: The filter rack on all downflows require two(2)16" x 18" cleanable high velocity filters. On furnaces with airflow below 1200 cfm a disposable filter can be used.

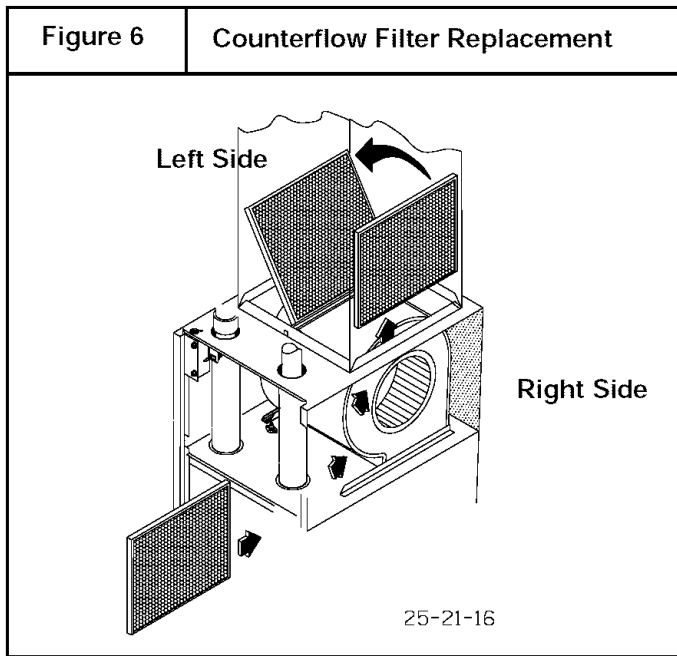

1. Remove compartment door.
2. Reach up above right side of blower and lift dirty filters out of rack at top of furnace.
3. Straighten up filters and pull straight down at side of blower. Pull out through right side of door opening.
4. Inspect the filter(s) and replace or clean washable types. If filter is aluminum mesh it should be recoated with filter coating spray.

5. Reinstall the filter in the filter rack.

Some filters are marked with an arrow to indicate the proper direction of air flow through the filter. The air flow direction will be towards the blower motor. Make sure filter is installed correctly.

6. Reinstall compartment door.

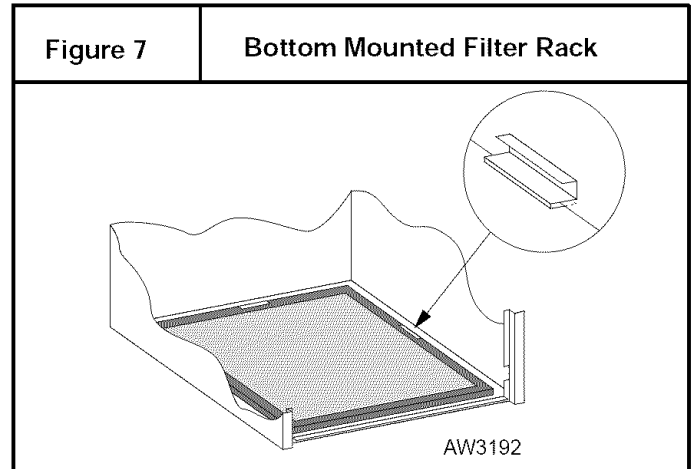

NOTE

Some filters are marked with an arrow to indicate the proper direction of air flow through the filter. The air flow direction will be towards the blower motor. Make sure filter is installed correctly.

Unit Size Heating Input 1000 x Btuh	Recommended Filter Sizes Nominal Air Flow Cubic Feet per Minute (CFM)	Recommended Filter Sizes Sq. In. Surface Area/Nominal Size (inches)	
		Disposable Filters	Cleanable Filters
		40 - 50	800-900
40 - 50, 75, and 100	900-1100	600 or 20 x 30	350 or 14 x 25
40 - 50, 75, and 100	1100-1300	350 or 14 x 25 (2Req.)	350 or 14 x 25
50, 75, 100, and 125	1300-1500	400 or 16 x 18 (2Req.)	400 or 16 x 18
100 and 125	1500-1700	500 or 20 x 25 (2 Req.)	500 or 20 x 25
125	1900-2100	600 or 20 x 30 (2 Req.)	500 or 20 x 25
150	2300-2500	600 or 20 x 30 (2 Req.)	720 or 24 x 30

Main Burner Flame/Monthly

To inspect the Pilot and Main Burner flame it will be necessary to remove the louvered panel on the front of the unit.

Check for the following through the view port:

- Stable and blue flames
- Flames extending directly from burner into heat exchanger.
- Flames do **NOT** touch sides of heat exchanger.

NOTE: Dust may cause orange tips or wisps of yellow, but flames **MUST NOT** have solid, yellow tips.

- Check main burner flames monthly.

Pilot Flame

While the main burner is **ON**, the flame should envelop the upper part of the Flame Sensor, as shown in **Figure 8**.

Contact a qualified service agency at once if an abnormal flame appearance is identified.

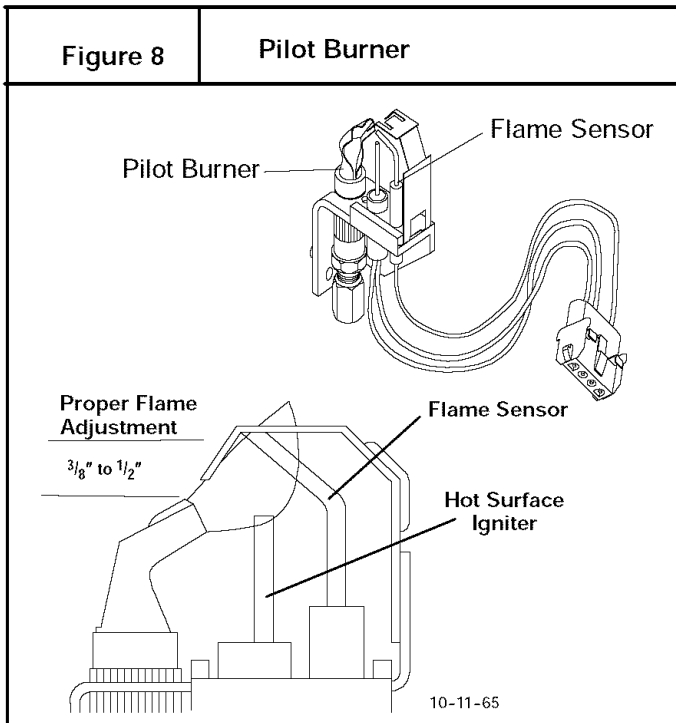

Monthly Inspection

A properly adjusted gas unit should not require cleaning at frequent intervals, but it should be inspected regularly to ensure safe and efficient operation. A brief monthly inspection is recommended that does not require disassembly. In addition you should have the unit inspected, and cleaned if required, by a qualified service technician annually.

1. Check the vents to be sure they are clear and free of obstructions.

2. Check return air duct to make sure it is sealed to unit casing and that it is in good physical condition.
3. Inspect the unit base. It must be in good physical condition.
4. Inspect the drain line and overflow line monthly.
5. Remove the front panel and use a flashlight to inspect the visible part of the burners and igniter. Check for loose soot and give particular attention to obvious deterioration from corrosion or other sources. If soot or deterioration is found inside the unit **DO NOT OPERATE UNIT**; call a qualified service technician.

Lubrication

The blower motor and the combustion air blower are prelubricated by the manufacturer and **DO NOT** require oiling.

Service Technician Checks

When the unit is being inspected for condition and operation have the Service Technician check the following items.

1. Check all flue gas passages including main and pilot burners, heat exchanger, and vent.
2. Check all flue gas passages including main and pilot burners, heat exchanger, and vent .
3. Check electrical wiring and connections.
4. Check supply and return air ducts for leakage, blockage and connections to unit.
5. Check circulating air blower wheel and motor. Clean them if required.
6. Perform an operational checkout on the unit to be sure safety controls function and that unit operates properly.

For additional information, the Service Technician can consult the installation instructions for the unit.

INTERNATIONAL COMFORT PRODUCTS
LIMITED WARRANTY CERTIFICATE
For Cooling & Heating Products

SAVE THIS CERTIFICATE. It gives you specific legal rights, and you may also have other rights which may vary from state to state and province to province.

If your unit needs servicing, contact a qualified dealer or qualified service technician of your choice. When requesting service, please have the model and serial number from each unit in your heating and/or cooling system readily available. If your dealer needs assistance, the distributor is available to provide support and we, in turn, support its efforts.

Fill in the installation date and model and serial numbers of the unit in the space provided below and retain this Limited Warranty for your files.

GENERAL TERMS

Subject to the conditions and limitations stated herein, during the term of this Limited Warranty, we will provide a replacement for any functional component part (as defined below) of your unit found to be defective in materials or workmanship. The term of this Limited Warranty is five years from installation on Residential Products and one year from installation on Commercial Products. Except as otherwise stated in the "Additional Terms" section, this Limited Warranty covers only the original purchaser and subsequent transferees, and only while the unit remains at the site of the original installation (except for mobile home installations), and only if the unit is installed inside the continental United States, Puerto Rico, Alaska, Hawaii or Canada. In addition, the Limited Warranty applies only if the unit is installed and operated in accordance with the printed instructions accompanying the unit, and in compliance with all applicable installation and building codes and good trade practices. As used in this Limited Warranty, "installation" means the original installation of the unit.

THERE ARE EXCEPTIONS to this Limited Warranty as described on the reverse side of this page. All replacement parts will be warranted for the unused portion of the warranty coverage period on the unit. The part to be replaced must be returned by the dealer to a distributor that sells products for International Comfort Products, in exchange for the replacement part. In lieu of providing a replacement part, we may, at our sole option, refund to you an amount equal to the distributor's component purchase price from us, or provide to you a credit equal to that amount to be applied toward the purchase of any new unit that we distribute. If a credit for a new unit is given in lieu of a replacement part, the rating plate from the unit being replaced must be submitted on a warranty claim, and your dealer must make the unit being replaced available to our distributor for disposition. As a condition to warranty coverage, the unit must receive yearly maintenance, as described in the owner's manual, by a dealer. Satisfactory proof of yearly service by a dealer may be required.

"Functional component parts" include only the following: blower motor, unit-mounted sensors & timers, condenser motor, evaporator coil, condenser coil, condenser fan, capacitor, transformer, single-phase strip heat elements, expansion device, reversing valve, solenoid valve, service valve, electronic and electro-mechanical control board, ignitor, ignition module, draft inducer assembly, burner pilot, gas valve, limit control, pressure switch, relays and contactors, blower wheel, interlock switch, crosslighter, pilot shield, gas & oil burners, oil pump assembly, accumulators and factory installed driers and strainers.

This Limited Warranty **DOES NOT COVER** any labor, material, refractory chambers, oil nozzles, refrigerant, refrigerant inspection and refrigerant reclaiming, freight and/or handling charges associated with any repair or replacement and such charges will be your responsibility.

To establish the installation date for any purpose under this Limited Warranty, you must retain the original records that can establish the installation date of your unit. If you do not provide such documents the start date of the term of this Limited Warranty will be based upon the date of unit manufacture, plus thirty (30) days. In establishing that the required yearly service has occurred, you must furnish proof of yearly service by a qualified service technician.

This Limited Warranty does not cover: (a) failure or damages caused by accident, abuse, negligence, misuse, riot, fire, flood, or Acts of God (b) damages caused by operating the unit where there is a corrosive atmosphere containing chlorine, fluorine, or any other damaging chemicals (other than those found in a normal residential environment) (c) damages caused by an unauthorized alteration or repair of the unit affecting its stability or performance (d) damages caused by improper matching or application of the unit or the unit's components (e) damages caused by failing to provide proper maintenance and service to the unit in accordance with this Limited Warranty Certificate and the printed instructions originally provided with the unit (f) any expenses incurred for erecting, disconnecting, or dismantling the unit (g) parts or supplies used in connection with service or maintenance, such as refrigerant, refractory chambers, oil nozzles, filters, or belts (h) damage, repairs, inoperation or inefficiency resulting from faulty installation or application (i) electricity or fuel costs or any increase in electricity or fuel cost whatsoever including additional or unusual use of supplemental electric heat (j) units which have not had the required yearly maintenance described elsewhere in this limited warranty.

In no event shall we be liable for any incidental, consequential, or special damages or expenses in connection with any use or failure of this unit.

We have not made, do not make, and hereby disclaim any implied condition or implied warranty of fitness for a particular use or purpose, and any implied condition or implied warranty of merchantability, to the fullest extent allowed by law. We make no express or implied warranties except as stated in this Limited Warranty certificate.

No one is authorized to change this Limited Warranty or to create for us any other obligation or liability in connection with this unit. Any implied warranties shall last for the term of the expressed warranty contained herein. Some states and provinces do not allow the exclusion or limitation of incidental or consequential damages or do not allow limitations on how long an implied warranty or condition lasts, so the above limitations or exclusions may not apply to you. The provisions of this Limited Warranty are in addition to and not a modification of or subtraction from any statutory warranties and other rights and remedies provided by law.

Please refer to reverse side of this page for additional terms.

Model No. _____

Serial No. _____ Date Installed _____

Effective on units installed After July 1, 2002.

USA: International Comfort Products Corporation (USA) • 650 Heil-Quaker Avenue • P.O. Box 128 • Lewisburg, Tennessee 37091 • (931-270-4100)
CANADA: International Comfort Products division of UTC Canada Corporation • 6060 Burnside Court, Unit 1, Mississauga, Ontario L5T 2T5 (905-795-8113).

Manufacturers of Airquest, Arcoaire, Clare, Comfortmaker, Dettson, Heil, Keeprite, Lincoln, Tempstar and other quality brand name private label products.

Part No. 401 06 1010 17 (Orig. 7/1/2002)

ADDITIONAL TERMS FOR RESIDENTIAL APPLICATIONS ONLY

The Additional Terms for the components listed below are in addition to, and subject to, the General Terms on the reverse side of this page. Warranty coverage is limited to parts that fail due to defect in materials or workmanship during the specified term.

CENTRAL GAS & OIL FURNACE HEAT EXCHANGERS*

Gas Model Series: C9MPV, H9MPV, T9MPV, C9MPT, H9MPT, T9MPT, C9MPD, H9MPD, T9MPD: Limited Lifetime Warranty on heat exchangers. If a heat exchanger on one of these furnaces fails due to defect in the part, we will provide a replacement part or, at our option, credit toward the purchase of a new furnace manufactured by us. This additional Limited Warranty runs only to the original purchaser, and lasts only for as long as the original purchaser lives in the home where the furnace is initially installed.** It is not transferable to any subsequent owner. If the furnace was not installed in the home owned by the original purchaser, if the original purchaser sells the home to a subsequent owner, or if proof of original purchase cannot be provided, then the limited warranty is only for 20 years from the date of original installation.

Gas Model Series: GDL, GNL, TNE, TDE, NTC7, NDC7, NTP6, NDP6, TDE, NTV6, VNE: A replacement heat exchanger will be provided for any heat exchanger that fails in one of these furnaces due to defect for 25 years from the original date of installation.

Gas Model Series: NTC6, GNE, GDE, NDN6, NTG3, NDN3, FBF, NBF, NDF, NTN3, NTN6, NNE, N9MP1, N9MP2, FUH: A replacement heat exchanger will be provided for any heat exchanger that fails in one of these furnaces due to defect for 20 years from original date of installation.

Oil Model Series: OLR(105, 160, 182), OCF, OLF, OUF, NOLF, NOUF, OLB, OHB, ODH, FLO, MBO, LBO, NOMF: Limited Lifetime Warranty on heat exchangers. If a heat exchanger on one of these furnaces fails due to defect in the part, we will provide a replacement part or, at our option, credit toward the purchase of a new furnace manufactured by us. This additional Limited Warranty runs only to the original purchaser, and lasts only for as long as the original purchaser lives in the home where the furnace is initially installed.** It is not transferable to any subsequent owner. If the furnace was not installed in the home of the original purchaser, if the original purchaser sells the home to a subsequent owner, or if proof of original purchase cannot be provided, then the limited warranty is only for 20 years from the date of original installation.

Oil Fired Floor Furnace: NFO: A replacement heat exchanger will be provided for any heat exchanger that fails due to defect for 10 years from installation with the following limitation: during the sixth through tenth year, any credit toward your purchase of a component or toward the purchase of any new unit will be in an amount equal to the distributor's purchase price reduced by 20 percent for each year after the fifth year.

ADDITIONAL TERMS FOR OIL FURNACE APPLICATIONS ONLY

- 1) OIL BURNERS - A replacement for 5 years from date of original installation for Oil Burner Parts.
- 2) OPTIONAL ACCESSORIES AND FUNCTIONAL PARTS: A replacement for 5 years from date of original installation. (Refractory and oil nozzles not included)

GAS/ELECTRIC PACKAGED UNITS HEAT EXCHANGERS

Model series: PGAD, PGAA, PGMD, PGME, PGF, GPFM, PGC, GPCM, PGK, GPK: A replacement for 10 years from original date of installation.

COMPRESSORS:*

1) **Premium Model Units: HAC0, HAC2, HAC4, CAC0, CAC2, CAC4, KAC0, TCA0, TCA2, TCA4, HHP0, HHP2, HHP4, CHP0, CHP2, CHP4, TCH0, TCH2, TCH4, PGME, PYMC, PGK, GPK, PHAD, PGAD, PA95, PAPC, PAK, APK:** To the original purchaser a replacement for 10 years from original date of installation, only if the unit is installed with factory matched coils, except air conditioner condensing units with a nominal SEER of 10 may be matched with evaporator coils of the same nominal tonnage regardless of manufacturer and in accordance to factory recommendations. This limited 10-year warranty is not transferable to any subsequent owner. HOWEVER, if the unit was not installed in the home owned by the original purchaser, if the purchaser sells the home to a subsequent owner, or if proof of original purchase cannot be provided, then the limited warranty is only for 5 years from the original date of installation.**

2) **All Other Models: Air Conditioners, Heat Pumps, & Combination Gas/Electric Units: NAC0, NAC2, NHP0, NHP2, AO, A2, HO, H2, PGE, GGC, GPFM, GPCM, PAF, APFM, PHF, HPFM, PGAA, PGMD, PA55, PH55, PAPA, PYPA:** A replacement for 5 years from date of original installation, only if: (a) air conditioner condensing units with SEER rating in the range of 10 to 11 SEER are matched with evaporator coils of the same nominal tonnage regardless of manufacturer and in accordance to factory recommendations, or (b) heat pump condensing units are used with factory matched coils, unless written approval to do otherwise is obtained from manufacturer.

ADDITIONAL TERMS FOR COMMERCIAL APPLICATIONS ONLY

For purposes of this warranty a commercial application is one in which: the product has over 5 tons nominal cooling capacity, or is designed for operation with 3 phase electrical power, or is installed in a commercial establishment such as a beauty or hair salon, hospital, school, restaurant, church, hotel etc..

3-Phase Models: PGF, GPFM, GPF, PGAD, PGME, PGB, PGMG, PGMF, PGS, PGE, APE, PAE, PAB, PAMD, PAS, PAF, APFM, APF, PHB, , PHE, PYMD, HPB, PHS, CAC, CAC, CAE, ACE, CHE, HCE:

The additional Terms of the components listed below are in addition to and subject to the General Terms on the reverse side of this page.

- 1) GAS FIRED HEAT EXCHANGERS (ALL MODELS):* A replacement for 10 years (5 years for PGS Series) from date of original installation.
- 2) COMPRESSORS (ALL MODELS):* A replacement for 5 years from date of original installation. (1 year for PGS/PAS240 and PGE/PAE 240 Model Series).*
- 3) OPTIONAL ACCESSORIES AND FUNCTIONAL COMPONENT PARTS (ALL MODELS):* A replacement for 1 year from date of original installation.
- 4) COMMERCIAL OIL MODELS: OLR210, OLR350, OTF210, AMT3, AMT4, AMP3: Ten(10) Year Limited Warranty on heat exchangers.

*To receive advantage of your limited warranty, you must provide proof of yearly service by a qualified service technician.

**To receive advantage of your warranty, you must retain the original records that can establish the installation date and proof of purchase of the unit.

MINI SPLITS:

Summary - Mini Splits Warranted for one (1) year on all replacement parts.

Additional terms for Mini Splits:

The additional Terms of the components listed below are in addition to, and subject to, the General Terms on the reverse side of this page.

1) **Compressors (All Models):** A replacement compressor will be provided for all compressors that fail due to defect for 5 years from date of original installation.

2) **Optional Accessories and Functional Components Parts (All Models):**

A replacement part will be provided for all parts that fail due to defect for one (1) year from date of original installation.

Failure to maintain the equipment through annual maintenance by a qualified service technician shall void the warranty. Proof of service will be required with all warranty claims. Proof of purchase and installation date must be submitted with all claims.