

User's Information Manual

Gas Furnaces

Condensing Gas Furnaces

90+ Four Position Furnaces

N9MP1, N9MP2, *9MPD, *9MPT & *9MPV

Non-Condensing Gas Furnaces

80+ Four Position Furnaces

N8MPN/L, *8MPN/L, *8MPT & *8MPV

*8DNL (Downflow only)



Installer: Affix these instructions on or adjacent to the furnace.
Consumer: Retain these instructions for future reference.

! WARNING

FIRE OR EXPLOSION HAZARD.

Failure to follow safety warnings exactly could result in death, serious injury and/or property damage.

- Do not store or use gasoline or other flammable vapors and liquids in the vicinity of this or any other appliance.
- **WHAT TO DO IF YOU SMELL GAS**
 - Do **NOT** try to light any appliance.
 - Do **NOT** touch any electrical switch; do **NOT** use any phone in your building.
 - Leave the building immediately
 - Immediately call your gas supplier from a neighbor's phone. Follow the gas supplier's instructions.
 - If you cannot reach your gas supplier, call the fire department.
- Installation and service must be performed by a qualified installer, service agency or the gas supplier.

International Comfort Products, LLC
Lewisburg, TN 37091

Contents

Danger, Warning and Caution	2	About Your Furnace	5
Safety Rules	3	Operating Your Furnace	8
Combustion Air (Your Safety)	4	Furnace Maintenance	9
Indoor Humidity (Your Comfort)	5	Warranty	15

Danger, Warning and Caution

Recognize safety information.

This is the safety-alert symbol . When you see this symbol on the furnace and in instruction manuals be alert to the potential for personal injury.

Understand the signal words **DANGER**, **WARNING** and **CAUTION**. These words are used to identify levels of hazard seriousness. The signal word **DANGER** is only used on product labels to signify an immediate hazard. The signal words **WARNING** and **CAUTION** will be used on product labels and throughout this manual and other manuals that may apply to the product.

Signal Words

DANGER - Immediate hazards which **WILL** result in severe personal injury or death.

WARNING - Hazards or unsafe practices which **COULD** result in severe personal injury or death.

CAUTION - Hazards or unsafe practices which **MAY** result in minor personal injury or product or property damage.

"NOTE" is used to highlight suggestions which will result in enhanced installation, reliability or operation.

Signal Words in Manuals

The signal word **WARNING** is used throughout this manual in the following manner:



The signal word **CAUTION** is used throughout this manual in the following manner:



Product Labeling

Signal words are used in combination with colors and/or pictures on product labels. Following are examples of product labels with explanations of the colors used.

Danger Label

White lettering on a black background except the word **DANGER** which is white with a red background.



Warning Label

White lettering on a black background except the word **WARNING** which is black with an orange background.



Caution Label

White lettering on a black background except the word **CAUTION** which is black with a yellow background.

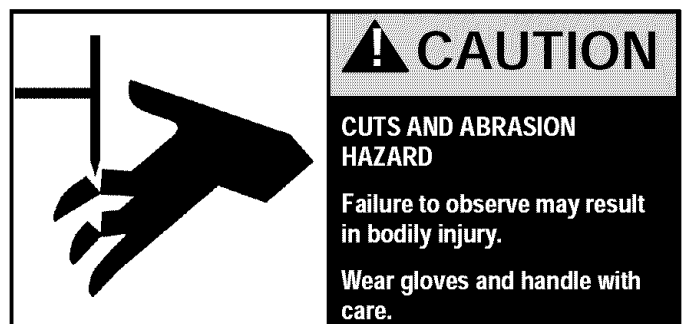

**WARNING****DEATH, PERSONAL INJURY AND/OR PROPERTY DAMAGE HAZARD**

Failure to observe and follow Cautions, Warnings and instructions could result in death, bodily injury or property damage.

Read this manual and follow its instructions and adhere to all Cautions and Warnings in the manual and on the furnace.

Consult a qualified service agency for installation, adjustment and maintenance.

Safety Rules

Your furnace is built to provide many years of safe and dependable service providing it is properly installed and maintained. However, abuse and/or improper use can shorten the life of the furnace and create hazards for you, the owner.

- A. The U.S. Consumer Product Safety Commission recommends that users of gas-burning appliances install carbon monoxide detectors. There can be various sources of carbon monoxide in a building or dwelling. The sources could be gas-fired clothes dryers, gas cooking stoves, water heaters, furnaces, gas-fired fireplaces, wood fireplaces, and several other items. Carbon monoxide can cause serious bodily injury and/or death. Carbon monoxide or "CO" is a colorless and odorless gas produced when fuel is not burned completely or when the flame does not receive sufficient oxygen.

Therefore, to help alert people of potentially dangerous carbon monoxide levels, you should have carbon monoxide detectors that are listed as complying with a standard by a nationally recognized agency (e.g. ANSI/UL 2034-2002, CSA 6.19-01, or International Approval Services 6-96) installed and maintained in the building or dwelling (see Note below).

- B. There can be numerous sources of fire or smoke in a building or dwelling. Fire or smoke can cause serious bodily injury, death, and/or property damage. Therefore, in order to alert people of potentially dangerous fire or smoke, you should have fire and smoke detectors that are listed by Underwriters Laboratories installed and maintained in the building or dwelling (see Note below).

Note: The manufacturer of your furnace does not test any detectors and makes no representations regarding any brand or type of detector.

- C. To ensure safe and efficient operation of your furnace, you should do the following:
1. **Thoroughly read this manual and labels on the furnace.** This will help you understand how your furnace operates and the hazards involved with gas and electricity.
 2. **The furnace area must be kept clear and free of combustible materials, gasoline, and other flammable vapors and liquids.**
 3. **Do not use this furnace if any part has been underwater.** A flood-damaged furnace is extremely dangerous. Attempts to use the furnace can result in fire or explosion. Immediately call a qualified service agency to inspect the furnace and to replace all control system parts, electrical parts, and gas controls which have been wet or the furnace, if deemed necessary.

4. **Never block or obstruct the openings on the furnace, or any ducts that provide air to the furnace.** Air must be provided for proper and safe operation of the furnace for combustion and ventilation of flue gases. See the "*Combustion Air (Your Safety)*" section of this manual.
5. **Familiarize yourself with the possible air starvation signals.** These are outlined in the Combustion Air section.
6. **Check the combustion air supply.** Some models use air drawn from outdoors, See **Figure 4**. Other models and other appliances use combustion air from inside the structure. Air starvation signals are given in the following "*Combustion Air (Your Safety)*". section of this manual. If any of the signals are noticed, perform a combustion air check as shown in the following *Combustion Air Checks* section of this manual or call a qualified service agency. If you add weather stripping, storm windows, insulation, an additional fuel burning appliance, or remodel the structure, a combustion air check **MUST** be accomplished after the addition.
7. **Maintain safety and service clearances from the furnace.** These clearances are listed on the furnace rating plate. Keep the furnace area clean and free of combustible materials at all times. Never store gasoline, paint, aerosol cans, waxes, bleaches, dry cleaning fluid or items such as paper or rags near the furnace.
8. **Examine the furnace area when the furnace or additional insulation is added since some insulation materials may be combustible.** Furnace must be kept free and clear of exposed or loose insulation materials in the area of installation.
9. **Check the return air duct connection.** The duct connection must be physically sound, sealed to the furnace casing and must terminate outside the space containing the furnace.
10. **Should the gas supply fail to shut off or if overheating occurs, shut off the gas valve to the furnace before shutting off the electrical supply.** Read the label on the front of the furnace and the Operating Your Furnace section of this manual for steps to turn off the furnace.
11. **Familiarize yourself with all controls.** Make sure you know how to shut off the gas and the electrical power to the furnace. Read the label on the front of the furnace and the Operating Your Furnace section of this manual for steps to start and turn off the furnace. If the furnace is to be shut down for an extended length of time (example; remodeling project), turn off both the gas and the electrical power. For safety, always turn them off before performing service or maintenance on the furnace.
12. **Establish a regular service and maintenance schedule.** This will ensure efficient and safe operation of the furnace. It is recommended that you have a qualified service agency perform a complete check on the furnace before each heating season. See furnace *Qualified Agency Checks and Combustion Air Checks* section of this manual.
13. **Monthly Inspection.** A properly adjusted gas furnace should not require cleaning at frequent intervals, but it should be inspected regularly to ensure safe and efficient operation. A brief monthly inspection is recommended that does not require disassembly. Examine the furnace installation to determine that:
 - a. All flue gas carrying areas external to the furnace (i.e. chimney, vent connector) are clear and free of obstructions.
 - b. The vent connector is in place, slopes upward and is physically sound without holes or excessive corrosion.

- c. (Upflow or downflow installations with duct connection at bottom only.) The physical support of the furnace is sound without sagging, cracks, gaps, etc., around the base so as to provide an air seal between the support and the base.
- d. There should be no obvious signs of deterioration of the furnace.
- e. Check that the pilot and burner flames are in good adjustment. To inspect the Pilot and Main Burner flames it will be necessary to remove the louvered door on the front of the furnace, except for furnaces not having any louvers in the doors. The doors of these furnaces must remain installed (to prevent changes in flame appearance) while inspecting the Pilot and Main Burner flames through the view port in the door. **Contact a qualified service agency at once if an abnormal flame appearance is identified.**

Main Burner Flame: Check for the following:

- Stable and blue flames. See Figure 1.
- Flames extending directly from burner into heat exchanger.
- Flames do NOT touch sides of heat exchanger.

NOTE: Dust may cause orange tips or wisps of yellow, but flames **MUST NOT** have solid, yellow tips.

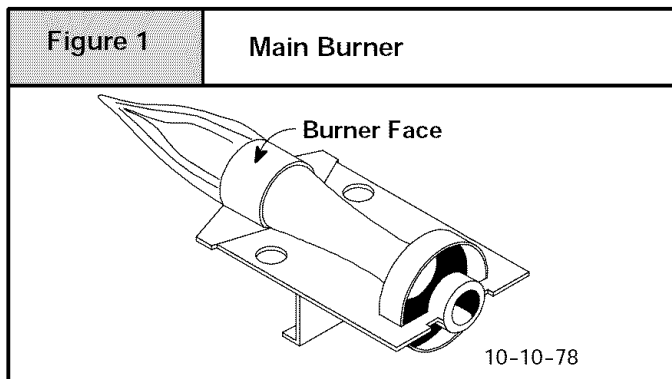

- Check main burner flames monthly.
- Check main burner flames monthly.

Pilot Burner Flame: While the main burner is **ON**, the flame should envelop the upper part of the Flame Sensor, as shown in Figure 2.

- f. With the equipment shutoff valve turned **OFF**, remove the burner compartment door of the furnace to use a flashlight to inspect the visible parts of the burners and igniter. Check for loose soot and give particular attention to obvious deterioration from corrosion or other sources. If soot or deterioration is found inside the furnace, **DO NOT OPERATE FURNACE**; call a qualified service agency.
- g. Inspect the drain line and overflow line monthly (condensing furnace and/or air conditioning cooling coil attached to furnace).

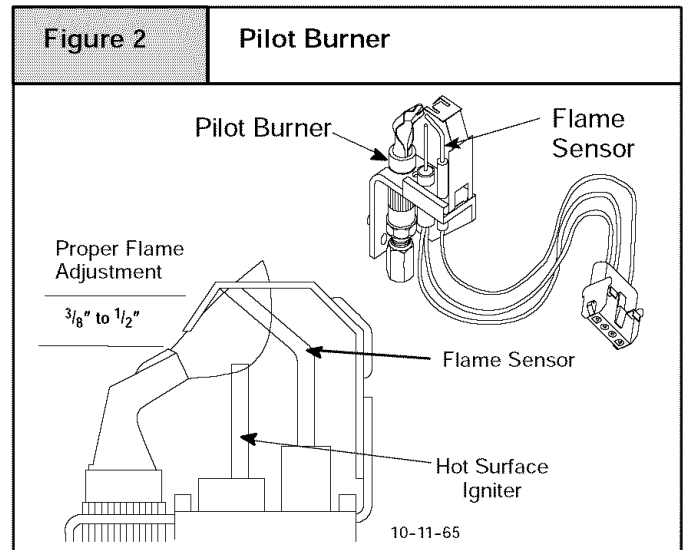

Combustion Air (Your Safety)

WARNING

CARBON MONOXIDE POISONING HAZARD

Lack of combustion air could result in carbon monoxide gas which could cause death or serious bodily injury.

All fuel-burning appliances must be provided with enough fresh air for proper combustion and ventilation of flue gases.

Some models use air from the space in which they are located, and other appliances in the same space may also be using indoor air for ventilation and/or combustion.

New materials and methods are being used in construction and remodeling which result in lower energy costs for heating and cooling. It may also mean your appliances may not be getting enough air for combustion and ventilation of flue gases. The use of exhaust fans, fireplaces, clothes dryers, and other appliances consume air or vent it to the outdoors.

If the gas appliances or heating furnace can't get enough air, two conditions may result:

1. The appliances or furnace may produce carbon monoxide gas.
2. The appliance may not vent flue gases properly. The following are signs that your appliances may not be getting enough air for proper combustion.

Be aware of these signals;

1. Headaches-Nausea-Dizziness
2. Excessive humidity-heavily frosted windows or a moist "clammy" feeling in the structure.
3. Smoke from the fireplace won't draw up the chimney.

⚠ WARNING

CARBON MONOXIDE POISONING HAZARD.
 Carbon monoxide poisoning could result in death from asphyxiation or serious bodily injury.
 If you experience headaches, nausea, or dizziness, carbon monoxide may be present.
 Leave the house immediately and call your gas supplier.

Combustion Air Checks

If any of the above signals are noticed, perform a combustion air check or call a qualified service agency. If you add weather stripping, storm windows, insulation, an additional fuel burning appliance, or remodel the structure, a combustion air check **MUST** be accomplished after the addition.

Make the inspection as follows:

1. Close all doors and windows. If you have a fireplace, start a fire and wait until flames are burning vigorously.
2. Turn on all exhausting devices, such as: kitchen and bathroom exhaust fans and dryers (gas or electric).
3. Turn on all vented gas appliances, such as: heating equipment (includes any room heaters) and water heaters.
4. Wait ten (10) minutes for drafts to stabilize.
5. On appliances with a draft hood, check for spillage by holding a lighted match 2" from the draft hood opening. Reference **Figure 3**, which shows a water heater draft hood.

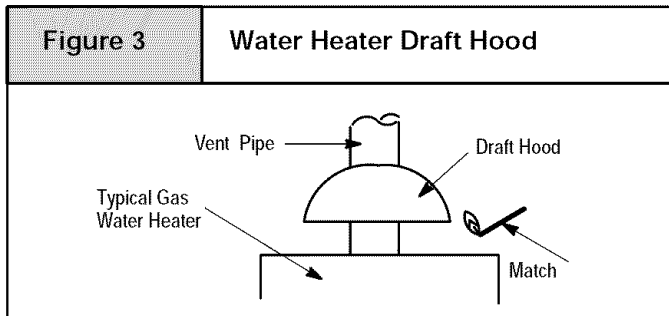

- A. *Match flame pulls toward draft hood.* This indicates no spillage and that appliance is getting enough air for combustion. Return exhausting devices and appliances to the condition in which you found them .
- B. *Match goes out or flame wavers away from draft hood.* This indicates spillage and that appliance is not getting enough air for combustion.

⚠ WARNING

CARBON MONOXIDE POISONING HAZARD.
 Carbon monoxide poisoning could result in death from asphyxiation or serious bodily injury.
 Draft hood spillage means there is not enough air for proper combustion and carbon monoxide may be present.
 Keep a window open (a minimum of 2") near the appliance until a permanent combustion air duct is installed. Contact a qualified service agency.

If draft hood spillage is indicated:

1. Check for plugged vent connectors and chimneys. Repair stoppage and test again.
2. If you have a fireplace, open a window or door near the fireplace and then check for spillage.
 If spillage stops, do not use the fireplace until you can supply fresh air by a permanent duct.
3. If you have kitchen and bathroom exhaust fans, turn them **OFF** and check for spillage.
 If spillage stops, do not use exhaust fans until you can supply fresh air by a permanent duct. Circuit breakers for fans should be turned off and marked as to why they are off.
4. Spillage means air starvation and that an outdoor air duct or air intake must be installed to provide air directly to the area around the furnace. This duct or intake **MUST** comply with local and state building codes or in their absence with the National Fuel Gas Code NFPA 54/ANSI Z223.1-2002 in the U.S., or the National Standard of Canada, Natural Gas and Propane Installation Code CSA B-149.1-00 in Canada.

Indoor Humidity (Your Comfort)

Relative humidity is important to your health. Proper humidification helps cut down incidences of respiratory illness. Air that is too wet may damage the building structure. Air that is too dry is uncomfortable. A quick way to test for proper humidity is as follows:

1. Look for frequent fogging or excessive condensation on the inside of windows. This indicates the indoor humidity level is too high for outdoor weather conditions.
2. Drop three ice cubes into a glass of water and stir. If, within three minutes, moisture does not form on the glass, the air is too dry and a humidifier would be beneficial. (Do not perform this test in the kitchen, cooking vapors may produce inaccurate results.)

A good relative humidity is one just high enough to barely start condensation along the lower edges or lower corners of the windows, when it is cold outside. More than that can be damaging.

If the humidity is too high, try these suggestions to lower the humidity:

1. Reduce setting or discontinue use of humidifier.
2. Use range and bathroom exhaust fans while cooking and bathing. Open a door or window for a few minutes to bring in cool drier air.
3. Cook with pans covered.
4. Take shorter baths or showers with cooler water.
5. Install a fresh air intake duct. Cold, dry air brought in from outside to the furnace area lowers the indoor humidity level.
6. Have appliances checked. A malfunctioning appliance can contribute water vapor to the structure.
7. If the problem continues, consult a heating contractor about adding a heat recovery ventilator or air-to-air heat exchanger.

About Your Furnace

Figure 4, Figure 5, or Figure 6 shows the location of the components in the furnace.

Circulating Air Blower

The blower circulates room air through the furnace, air ducts, and into the rooms of the structure. The blower can be set at the thermostat for automatic or manual operation. In manual mode the blower operates continuously. In automatic, the blower does not come on until a preset time after the gas valve is energized. When the structure reaches the temperature set on the thermostat, the furnace will shut off. The blower will continue to run until the furnace cools down.

Thermostat

There are many types and styles of thermostats. Most thermostats control both heating and cooling functions and have a Fan Switch with **AUTO** and **ON** settings. On **AUTO**, the Circulating Air Blower will cycle on/off with the furnace on the heating speed un-

less a call for cooling is initiated. Blower speed will correspond to the mode of operation of the furnace. If the Fan Switch is positioned to **ON** the blower will run continuously.

In addition some thermostats are programmable with multiple set backs. The set backs can be pre-programmed to lower or raise the temperature automatically.

Be sure to become familiar with your thermostat.

Rating Plate

The rating plate contains important information for the service technician and lists the complete model, manufacturing and serial numbers. You should always provide all these numbers when requesting parts or if you need service. See **Figure 4**, **Figure 5**, or **Figure 6** for rating plate location.

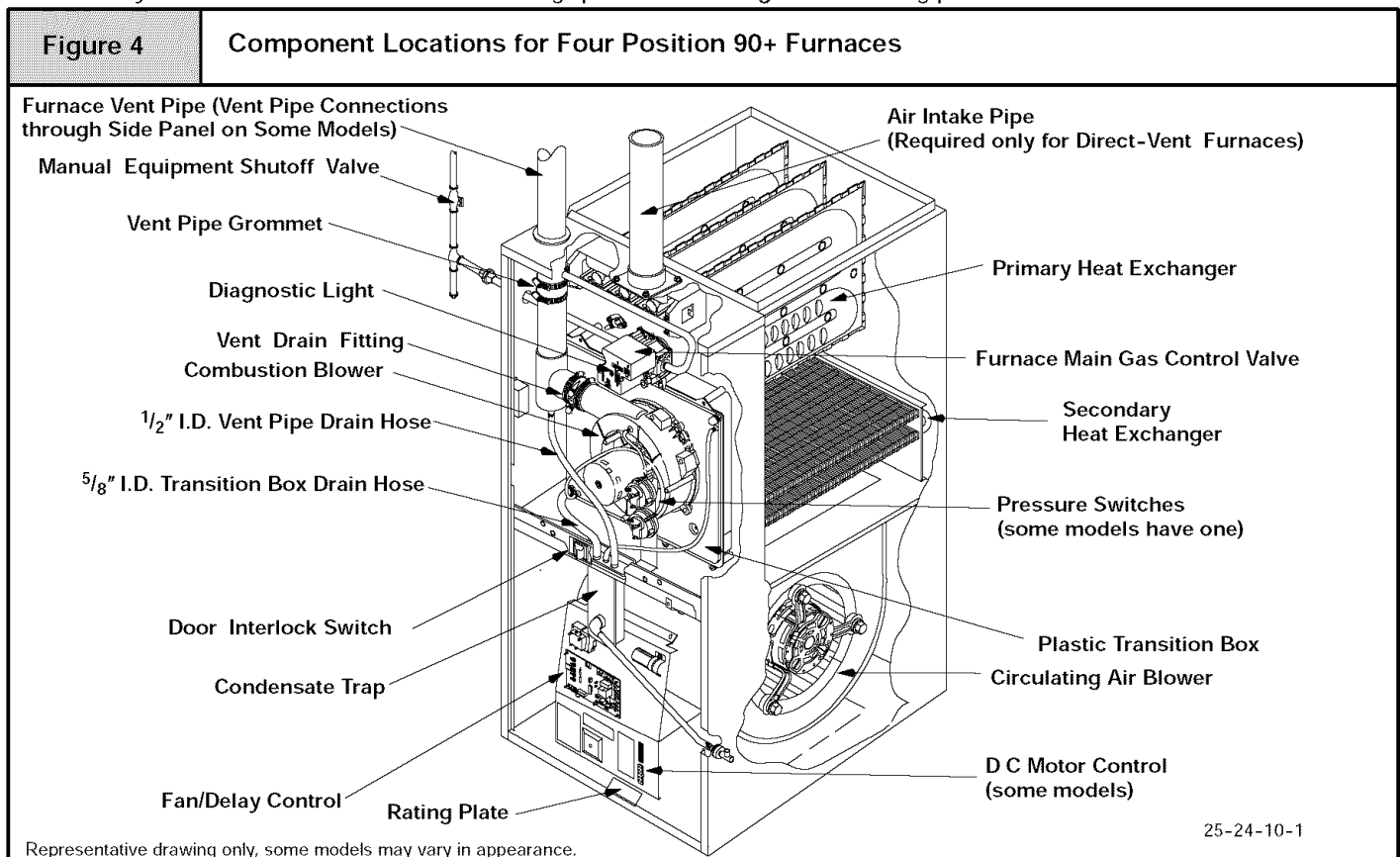

Door Interlock Switch

All the electrical power for the furnace goes through the door interlock switch. The interlock switch interrupts electrical power to the furnace when the blower door is removed. The furnace will not operate until the blower door is reinstalled.

Fan Control

The fan/delay control provides power to the circulating air blower to keep it on until the furnace cools down.

The fan off-delay setting can be adjusted if the fan remains on long enough that cool drafts are felt in the room after the furnace shuts off.

The off-delay is set by moving a set of switches on the control. The Wiring Diagram located on the inside of the blower door shows the various delay combinations. Refer to **Figure 4**, **Figure 5**, or **Figure 6** for location of the control.

If you are unsure how to set the Fan Control, contact a Qualified Service Agency.

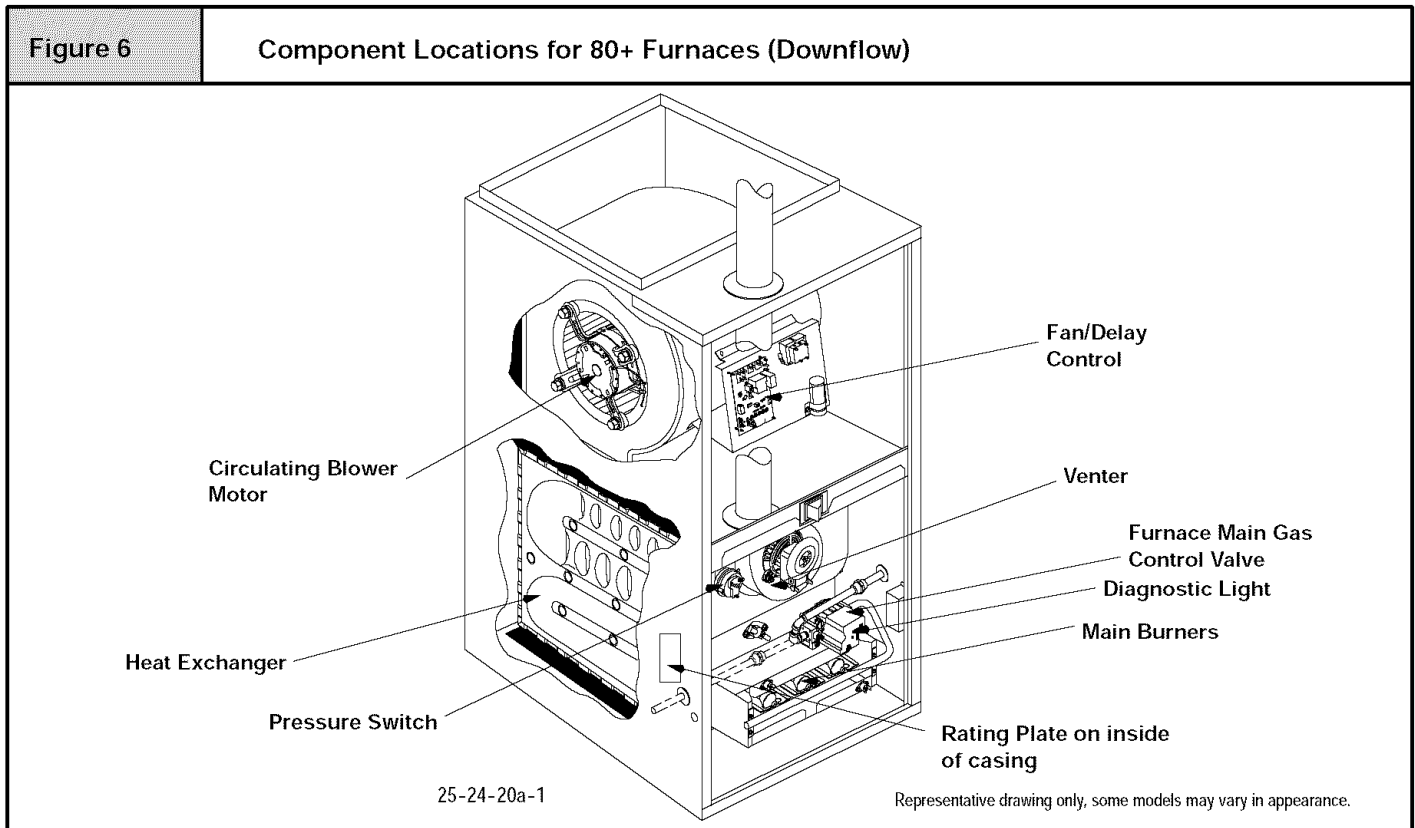
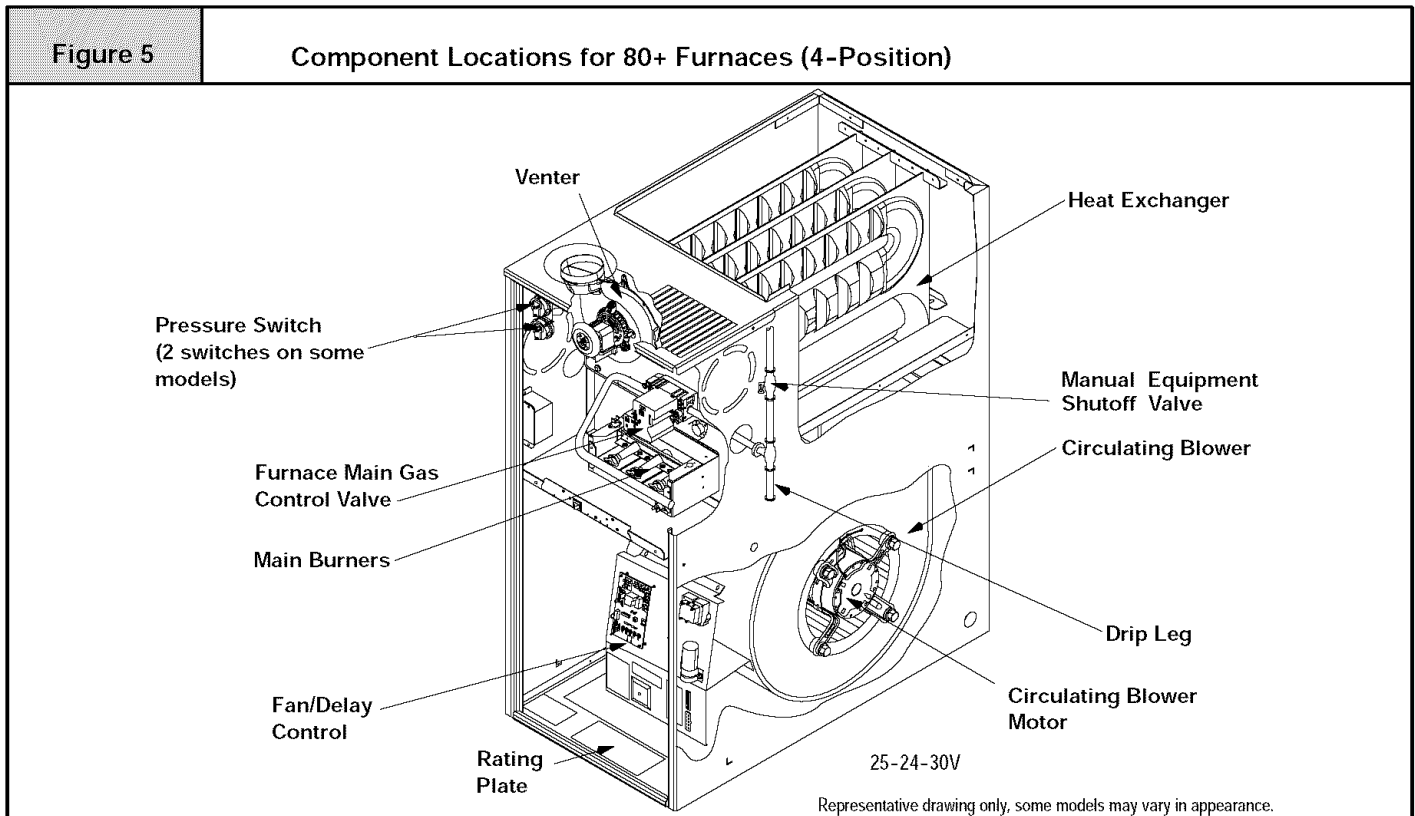

Electronic Ignition Module/Gas Control Valve

When the thermostat calls for heat it completes a circuit to the electronic ignition module. The module sends an electrical signal which ignites the pilot, and then opens the gas valve.

When the flame is firmly established, the igniter shuts off. If there is a malfunction, the gas valve automatically shuts off the gas.

Pressure Switch

The furnace is equipped with one or more pressure switches to shut down the furnace under various flue conditions. The switches are connected to the furnace by factory supplied tubing.

Operating Your Furnace

Keep the blower access door and all access panels in place except for inspection or maintenance.

Before starting your furnace be sure you read and understand all of the procedures in this manual. Check to make sure the furnace filter is clean and correctly installed.

! WARNING

CARBON MONOXIDE POISONING HAZARD

Failure to provide adequate combustion and ventilation air could result in death and/or personal injury.

Provisions for combustion and ventilation air must be provided for in accordance with installation instructions supplied with furnace.

Starting The Furnace

See **Figure 7** for an illustration of the gas control valve.

1. Turn the thermostat to its lowest temperature setting or to **OFF** if equipped with a System Select Switch.
2. Turn **OFF** all electric power to the furnace at the disconnect switch or circuit breaker.
3. Remove the burner compartment door by removing the two(2) screws securing the door in front and lifting the door up and outwards. Removing the door will expose the gas control valve switch.
4. Slide the gas control valve switch to **OFF**. See **Figure 7**.
5. Wait five (5) minutes to clear out any gas. If you then smell gas, **STOP!** Follow the safety information on the cover of this manual. If you do not smell gas, go to the next step.
6. Slide the control valve switch to **ON**.
7. Reinstall all doors.
8. Turn **ON** all electrical power to the furnace.
9. Set the thermostat to the desired temperature and the System Select Switch to **HEAT**.

The furnace will activate an igniter which lights the pilot flame. When the pilot lights and verifies a steady flame, the ignition system brings on the main burners.

System Retries

The ignition system tries to relight the burners whenever the built-in flame sensor detects no flame while the thermostat calls for heat.

Turning Off The Furnace

Set the thermostat to the lowest temperature setting or set System Select Switch to **OFF**, if so equipped.

Should overheating occur or the gas control valve fail to shut off, shut off the manual equipment shutoff valve to the furnace before shutting off the electrical supply.

Extended Shutdown

1. Set thermostat to lowest temperature setting or set thermostat System Select Switch to **OFF**, if so equipped.
2. Turn Manual Equipment Shutoff Valve for furnace to **OFF** position (at right angle or 90° to gas line).
3. Remove the burner compartment door by removing the two (2) screws securing the door in front and lifting the door up and outwards. Removing the door will expose the gas control valve switch.
4. Slide the gas control valve switch to **OFF**.
5. Turn **OFF** electric power to the furnace at the disconnect switch or circuit breaker. (May be left **ON** for set-back type thermostat with batteries, provided thermostat has system select switch placed in the **OFF** position.)
6. Reinstall all doors.

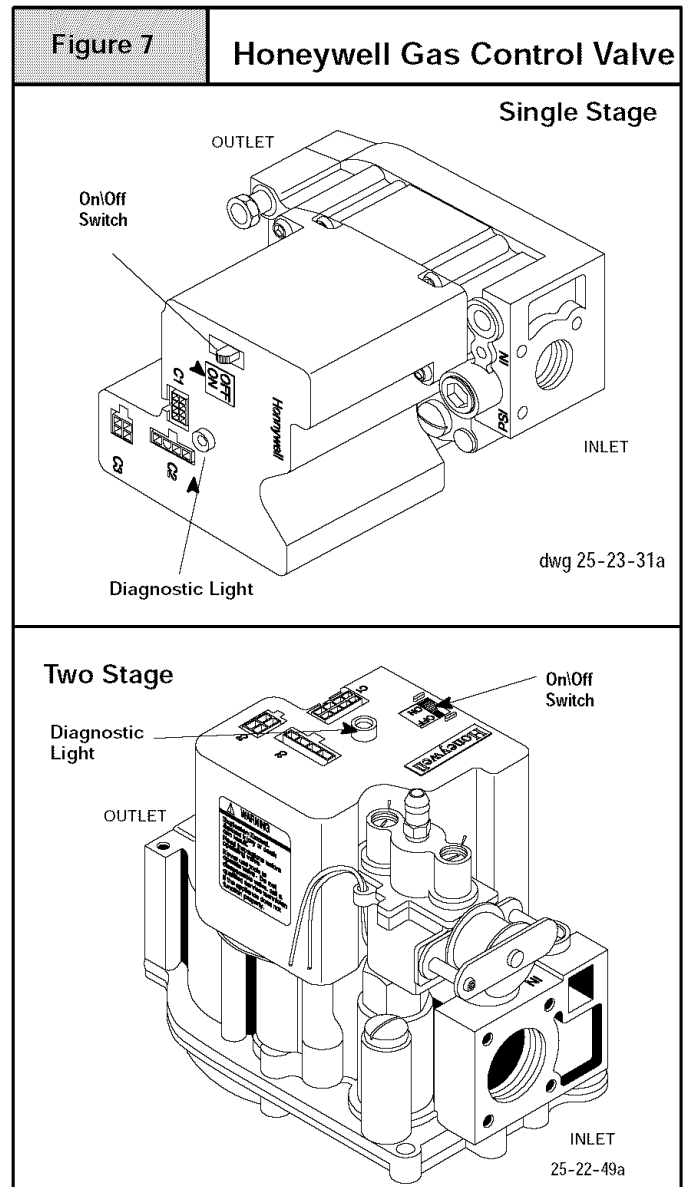

L P Model Furnaces

WARNING

FIRE OR EXPLOSION HAZARD

Failure to detect and stop gas leak could result in death, bodily injury, or property damage.

Propane gas is heavier than air. Leaking gas can settle in low areas such as crawl space. If you suspect the presence of gas, follow the instructions on the cover of this manual.

If your L.P. (liquefied petroleum) gas furnace is installed in an excavated or low lying area, we recommend that you contact your L.P. gas supplier about installing a warning device that would alert you of a gas leak.

Frozen Water Pipe Hazard

CAUTION

FROZEN AND BURST WATER PIPE HAZARD.

Failure to protect against frozen pipes may result in burst water pipes, serious property damage and/or personal injury.

Furnace may shut down. Do not leave your home unattended for long periods during freezing weather without turning off water supply and draining water pipes or otherwise protecting against the risk of frozen pipes.

Your furnace is designed solely to provide a safe and comfortable living environment. The furnace is NOT designed to ensure that water pipes will not freeze. It is equipped with several safety devices that are designed to turn the furnace off and prevent it from restarting in the event of various potentially unsafe conditions.

If your furnace remains off for an extended time, the pipes in your home could freeze and burst, resulting in serious water damage.

If the structure will be unattended during cold weather, you should take these precautions.

1. Turn off the water supply to the structure and drain the water lines if possible and add an antifreeze for potable water to drain traps and toilet tanks. Open faucets in appropriate areas.

-or-

2. Have someone check the structure frequently during cold weather to make sure it is warm enough to prevent pipes from freezing. Instruct them on a qualified service agency to call to provide service, if required.

-or-

3. Install a reliable remote sensing device that will notify somebody of freezing conditions within the home.

Winter Shutdown (90+ Furnaces)

If you go away during the winter months and do not leave the heat on in your home, the plastic transition box and the condensate trap on the furnace must be protected from freeze damage. (See **Figure 4**)

1. Disconnect the $\frac{1}{2}$ " I.D. rubber hose from the vent drain fitting (or tee) that is located downstream of the combustion blower. Insert a funnel into the hose and pour four (4) ounces of sanitary type (RV) antifreeze into the condensate trap. Reconnect the $\frac{1}{2}$ " I.D. rubber hose to the stub on the vent drain fitting. Secure with the hose clamp.
2. Disconnect the $\frac{5}{8}$ " I.D. rubber hose from the condensate trap. Insert a funnel into the hose and pour four (4) ounces of sanitary type (RV) antifreeze into the plastic transition box. Squeeze the hose together near the end and quickly reconnect the $\frac{5}{8}$ " I.D. rubber hose to the stub on the condensate trap. Secure with the hose clamp.

When you return home, your furnace will be ready to start, as it is not necessary to drain the antifreeze from the furnace.

Furnace Maintenance

Have your furnace inspected and serviced on an annual basis (before the heating season) by a qualified service agency.

Labeling

WARNING

FIRE OR EXPLOSION HAZARD

Wiring errors can cause improper and dangerous operation that could result in death, bodily injury, and/or property damage.

Label all wires prior to disconnection when servicing controls. Verify proper operation after servicing. Only qualified service agencies should attempt electrical service.

Pressure Switches

During regular yearly maintenance, check for cracks in any tubes on the pressure switches.

WARNING

ELECTRIC SHOCK HAZARD

Failure to disconnect electricity could result in death or bodily injury.

Turn off electrical power to furnace before performing any maintenance or removing panels or doors.

Air Filters/Monthly

The air filter(s) should be inspected at least monthly and cleaned or replaced as required. There are two types of filters that are commonly used. Washable filters (constructed of aluminum mesh, foam, or reinforced fibers) may be cleaned by soaking in mild detergent and rinsing with water. The fiberglass disposable type should be **REPLACED** before it becomes clogged.

Remember that dirty filters are the most common cause of inadequate heating or cooling performance.

⚠ CAUTION**RISK OF REDUCED FURNACE LIFE**

Use of excessively dirty and/or restrictive air filters may increase furnace operating temperatures and shorten the life of the furnace.

Filters specified for the furnace are rated at a maximum of 600 FPM air velocity and sized for the furnace's airflow rate. Replacement filters must be of equivalent type, size, and rating except as described below.

Disposable, low-velocity filters may be used to replace washable, high-velocity filters, providing they are sized for 300 FPM or less.

If you are uncertain of the type of replacement filter to use, consult the furnace installer or a qualified service agency for assistance.

Replacement Filters

If the filter is not located at or within the furnace, it should be located somewhere in the return-air duct system.

The recommended sizes and types of filters that may be used with your furnace are based on the furnace's heating gas input rate (and cooling system capacity, if so equipped).

Replacement filters should be of the same type and size as the original filters, to ensure adequate air flow and filtering. A disposable low velocity filter can be replaced with a washable high velocity type. Do not replace a high velocity filter with a disposable low velocity filter, except as permitted below.

If a cleanable (high-velocity) filter(s) is to be replaced with a disposable (low-velocity) filter(s), the airflow area of the filter(s) must be doubled (i.e., a second filter of the same size must be installed so that only half of the air goes through each filter). A second return-air duct to the furnace may be required in which to install the second filter. Modification of a furnace installation shall comply with the local installation code and the furnace installation instructions, and shall be made only by a Qualified Service Agency.

NOTE: Some filters are marked with an arrow to indicate the proper direction of air flow through the filter. The air flow direction will be towards the blower motor. Make sure filter is installed correctly.

Filter Replacement - Upflow (*8MPN/L)

The filter may be installed inside the bottom of the furnace blower compartment, or the filter(s) rack may be installed under the furnace or on either or both sides of the furnace. A plastic end cap(s) is inserted in the filter rack(s) after the filter(s) is installed. The end cap keeps air from escaping around the open end of the filter rack. See **Figure 8** and **Figure 9** for side and bottom locations. Rack end cap is similar for bottom mounted filter rack.

Filter rack(s) attached to the outside of the furnace is made so the filter simply slides out one end for removal.

Filter Replacement - Bottom or Side Mounted Filter Rack Outside Furnace

1. Turn **OFF** electric power to furnace.
2. Remove the end cap from the filter rack.

3. Slide the filter out of the filter rack. See **Figure 8**.
4. Inspect the filter(s) and replace or clean washable types. If filter is aluminum mesh it should be recoated with filter coating spray.
5. Reinstall the end cap in the filter rack.
6. Turn on electric power to furnace.

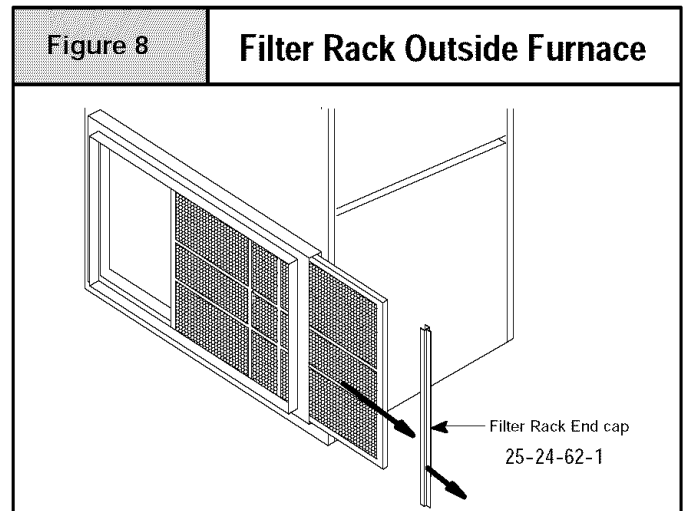
**Filter Replacement - Bottom Mounted Filter Inside Furnace, (*8MPN/L)**

1. Turn off electric power to furnace.
2. Remove blower door.
3. Slide filter straight out toward you. See **Figure 9**.
4. Inspect the filter(s) and replace or clean washable types. If filter is aluminum mesh it should be recoated with filter coating spray.
5. Replace blower door.
6. Turn on electric power to furnace.

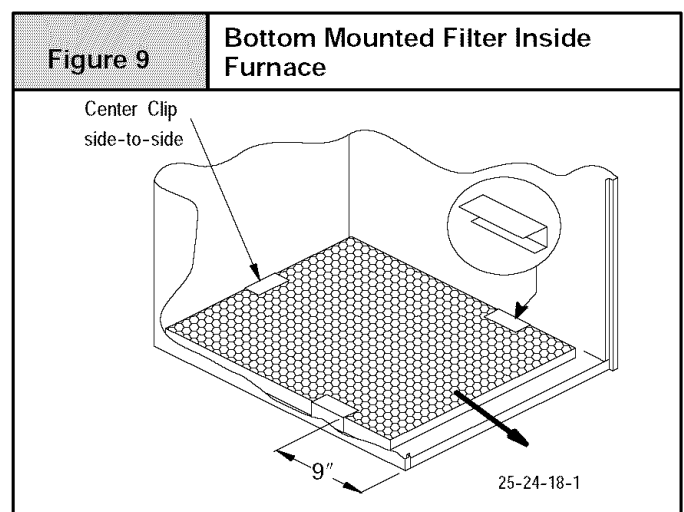
**Filter Replacement - Horizontal and Downflow *8MPN/L (Not *8DNL)**

The filter may be installed at the inlet end of the blower compartment, either inside or outside the furnace. Side inlet filter locations are not permitted for horizontal or downflow applications.

External Filter Rack

A plastic end cap is inserted in the filter rack after the filter is installed. The end cap keeps air from escaping around the open end of the filter rack. See **Figure 8** for removal of filter.

Filter racks attached to the furnace are made so the filter simply slides out one end for removal.

1. Turn **OFF** electric power to furnace.
2. Remove the end cap from the filter rack.
3. Slide the filter out of the filter rack.
4. Inspect the filter(s) and replace or clean washable types. If filter is aluminum mesh it should be recoated with filter coating spray.
5. Reinstall the end cap in the filter rack.
6. Turn furnace on.

Internally Mounted Filter

1. Turn **OFF** power to furnace.
2. Remove blower door.
3. Slide filter straight out toward you. (See **Figure 9**.)
4. Inspect the filter(s) and replace or clean washable types. If filter is aluminum mesh it should be recoated with filter coating spray.
5. Replace blower door
6. Turn on electric power to furnace.

Filter Replacement -- Downflow *8DNL (Not *8MPN/L)

Two filters are supplied with all *8DNL downflow models. (See to **Figure 10**) Refer to note for proper size. The filters are installed through the top of the downflow furnace from the right side. To remove filter, refer to **Figure 10** for the following steps.

NOTE: Two (2) 16" x 18" cleanable high-velocity filters are recommended. A *8DNL downflow furnace with airflow up to 1200 cfm is permitted to replace the 16" x 18" cleanable high-velocity filters with two 16" x 18" disposable filters.

1. Turn **OFF** power to furnace.
2. Remove compartment door.
3. Reach up above right side of blower, and lift dirty filters out of rack at top of furnace.
4. Straighten up filters and pull straight down at side of blower. Pull out through right side of door opening.
5. Inspect the filter(s) and replace or clean washable types. If filter is aluminum mesh, it should be recoated with filter coating spray.
6. Reinstall the filters in the filter rack.
7. Reinstall blower compartment door.
8. Turn **ON** electric power to the furnace.

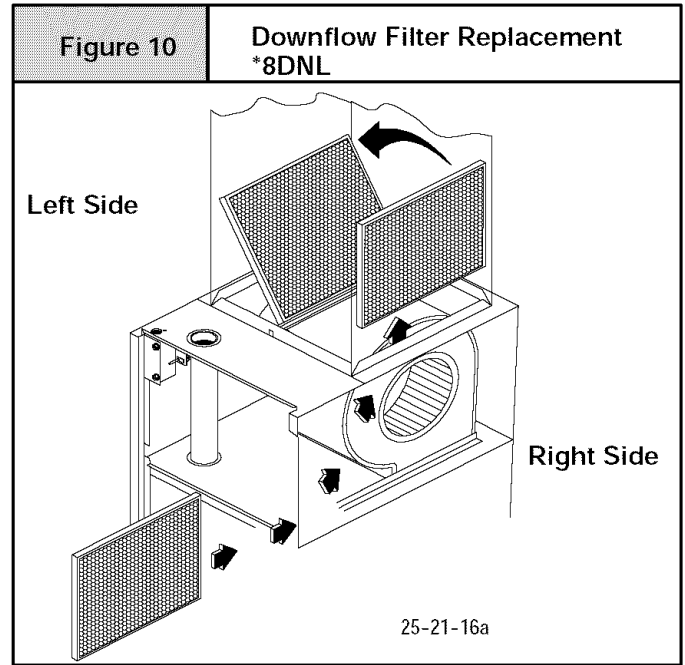

Table 1		Recommended Filter Sizes	
furnace Size Heating Input 1000 x Btuh	Nominal Air Flow Cubic Feet per Minute (CFM)	Recommended Filter Sizes Sq. In. Surface Area/Nominal Size (inches)	
		Disposable Filters	Cleanable Filters
50	800-900	500 or 20 x 25	350 or 14 x 25
50, 75, and 100	1100-1300	350 or 14 x 25 (2Req.)	350 or 14 x 25
50, 75, 100, and 125	1300-1500	400 or 16 x 18 (2Req.)	400 or 16 x 18
100 and 125	1500-1700	500 or 20 x 25 (2 Req.)	500 or 20 x 25
125	1900-2100	600 or 20 x 30 (2 Req.)	500 or 20 x 25
150	2300-2500	600 or 20 x 30 (2 Req.)	720 or 24 x 30

Lubrication

The blower motor and the combustion air blower are pre-lubricated by the manufacturer and **DO NOT** require oiling.

Qualified Service Agency Checks

When the furnace is being inspected for condition and operation have the Qualified Service Agency check the following items.

1. Check all flue gas passages including main and pilot burners, heat exchanger, and vent.

2. Check electrical wiring and connections.
3. Check supply and return air ducts for leakage, blockage and connections to furnace.
4. Check circulating air blower wheel and motor. Clean them if required.
5. Perform an operational checkout on the furnace to be sure safety controls function and that furnace operates properly.

For additional information, the Qualified Service Agency can consult the installation instructions for the furnace.

INTERNATIONAL COMFORT PRODUCTS
LIMITED WARRANTY CERTIFICATE
For Cooling & Heating Products

SAVE THIS CERTIFICATE. It gives you specific legal rights, and you may also have other rights which may vary from state to state and province to province.

If your unit needs servicing, contact a qualified dealer or qualified service agency of your choice. When requesting service, please have the model and serial number from each unit in your heating and/or cooling system readily available. If your dealer needs assistance, the distributor is available to provide support and we, in turn, support its efforts.

Fill in the installation date and model and serial numbers of the unit in the space provided below and retain this Limited Warranty for your files.

GENERAL TERMS

Subject to the conditions and limitations stated herein, during the term of this Limited Warranty, we will provide a replacement for any functional component part (as defined below) of your unit that fails due to defect in materials or workmanship. The term of this Limited Warranty is five years from installation on Residential Products and one year from installation on Commercial Products or applications. Except as otherwise stated in the "Additional Terms" section, this Limited Warranty covers only the original purchaser and subsequent transferees, and only while the unit remains at the site of the original installation (except for mobile home installations), and only if the unit is installed inside the continental United States, Puerto Rico, Alaska, Hawaii or Canada. In addition, the Limited Warranty applies only if the unit is installed and operated in accordance with the printed instructions accompanying the unit, and in compliance with all applicable installation and building codes and good trade practices. As used in this Limited Warranty, "installation" means the original installation of the unit.

THERE ARE EXCEPTIONS to this Limited Warranty as described on the reverse side of this page. All replacement parts will be warranted for the unused portion of the warranty coverage period on the unit. The part to be replaced must be returned by the dealer to a distributor that sells products for International Comfort Products, in exchange for the replacement part. In lieu of providing a replacement part, we may, at our sole option, refund to you an amount equal to the distributor's component purchase price from us, or provide to you a credit equal to that amount to be applied toward the purchase of any new unit that we distribute. If a credit for a new unit is given in lieu of a replacement part, the rating plate from the unit being replaced must be submitted on a warranty claim, and your dealer must make the unit being replaced available to our distributor for disposition. As a condition to warranty coverage, the unit must receive yearly maintenance, as described in the owner's manual, by a dealer. Satisfactory proof of yearly service by a dealer may be required.

"Functional component parts" include only the following: blower motor, unit-mounted sensors & timers, condenser motor, evaporator coil, condenser coil, condenser fan, capacitor, transformer, single-phase strip heat elements, expansion device, reversing valve, solenoid valve, service valve, electronic and electro-mechanical control board, ignitor, ignition module, draft inducer assembly, burner pilot, gas valve, limit control, pressure switch, relays and contactors, blower wheel, interlock switch, crosslighter, pilot shield, gas & oil burners, oil pump assembly, accumulators and factory installed driers and strainers.

This Limited Warranty **DOES NOT COVER** any labor, material, refractory chambers, oil nozzles, refrigerant, refrigerant inspection and refrigerant reclaiming, freight and/or handling charges associated with any repair or replacement and such charges will be your responsibility.

To establish the installation date for any purpose under this Limited Warranty, you must retain the original records that can establish the installation date of your unit. If you do not provide such documents the start date of the term of this Limited Warranty will be based upon the date of unit manufacture, plus thirty (30) days. In establishing that the required yearly service has occurred, you must furnish proof of yearly service by a qualified service agency.

This Limited Warranty does not cover: (a) failure or damages caused by accident, abuse, negligence, misuse, riot, fire, flood, or Acts of God (b) damages caused by operating the unit where there is a corrosive atmosphere containing chlorine, fluorine, or any other damaging chemicals (other than those found in a normal residential environment) (c) damages caused by an unauthorized alteration or repair of the unit affecting its stability or performance (d) damages caused by improper matching or application of the unit or the unit's components (e) damages caused by failing to provide proper maintenance and service to the unit in accordance with this Limited Warranty Certificate and the printed instructions originally provided with the unit (f) any expenses incurred for erecting, disconnecting, or dismantling the unit (g) parts or supplies used in connection with service or maintenance, such as refrigerant, refractory chambers, oil nozzles, filters, or belts (h) damage, repairs, inoperation or inefficiency resulting from faulty installation or application (i) electricity or fuel costs or any increase in electricity or fuel cost whatsoever including additional or unusual use of supplemental electric heat (j) units which have not had the required yearly maintenance described elsewhere in this limited warranty.

In no event shall we be liable for any incidental, consequential, or special damages or expenses in connection with any use or failure of this unit.

WE HAVE NOT MADE, DO NOT MAKE, AND HEREBY DISCLAIM ANY IMPLIED CONDITION OR IMPLIED WARRANTY OF FITNESS FOR A PARTICULAR USE OR PURPOSE, AND ANY IMPLIED CONDITION OR IMPLIED WARRANTY OF MERCHANTABILITY, TO THE FULLEST EXTENT ALLOWED BY LAW. WE MAKE NO EXPRESS OR IMPLIED WARRANTIES EXCEPT AS STATED IN THIS LIMITED WARRANTY CERTIFICATE.

No one is authorized to change this Limited Warranty or to create for us any other obligation or liability in connection with this unit. Any implied warranties that are not disclaimable shall last only for the term of the express warranty contained herein. Some states and provinces do not allow the exclusion or limitation of incidental or consequential damages or do not allow limitations on how long an implied warranty or condition lasts, so the above limitations or exclusions may not apply to you. The provisions of this Limited Warranty are in addition to and not a modification of or subtraction from any statutory warranties and other rights and remedies provided by law.

Please refer to reverse side of this page for additional terms.

Model No. _____

Serial No. _____ Date Installed _____

USA: International Comfort Products, LLC • 650 Heil-Quaker Avenue • P.O. Box 128 • Lewisburg, Tennessee 37091 • (931-270-4100)
CANADA: International Comfort Products division of UTC Canada Corporation • 6060 Burnside Court, Unit 1, Mississauga, Ontario L5T 2T5 (905-795-8113).
Manufacturers of Airquest, Arcoaire, Clare, Comfortmaker, Dettson, Heil, Keeprite, Lincoln, Tempstar and other quality brand name private label products.

Part No. 401 06 1010 24 (Orig. 11/03/2003)

ADDITIONAL TERMS FOR RESIDENTIAL APPLICATIONS ONLY

The Additional Terms for the components listed below are in addition to, and subject to, the General Terms on the reverse side of this page. Warranty coverage is limited to parts that fail due to defect in materials or workmanship during the specified term.

CENTRAL GAS & OIL FURNACE HEAT EXCHANGERS*

Gas Model Series: C9MPV, H9MPV, T9MPV, C9MPT, H9MPT, T9MPT, C9MPD, H9MPD, T9MP: Limited Lifetime Warranty on heat exchangers. If a heat exchanger on one of these furnaces fails due to defect in the part, we will provide a replacement part or, at our option, credit toward the purchase of a new furnace manufactured by us. This additional Limited Warranty runs only to the original purchaser, and lasts only for as long as the original purchaser lives in the home where the furnace is initially installed.** It is not transferable to any subsequent owner. If the furnace was not installed in the home owned by the original purchaser, if the original purchaser sells the home to a subsequent owner, or if proof of original purchase cannot be provided, then the limited warranty is only for 20 years from the date of original installation.

Gas Model Series: T8MPV, H8MPV, C8MPV, T8MPT, H8MPT, C8MPT: A replacement heat exchanger will be provided for any heat exchanger that fails in one of these furnaces due to defect for 25 years from the original date of installation.

Gas Model Series: T8MPN, H8MPN, C8MPN, T8MPL, H8MPL, C8MPL, T8DNL, H8DNL, C8DNL, N8MPN, N8MPL, N9MP1, N9MP2: A replacement heat exchanger will be provided for any heat exchanger that fails in one of these furnaces due to defect for 20 years from original date of installation.

Oil Model Series: OLR(105, 160, 182), OCF, OLF, OUF, NOLF, NOUF, OLB, OHB, ODH, FLO, MBO, LBO, NOME: Limited Lifetime Warranty on heat exchangers. If a heat exchanger on one of these furnaces fails due to defect in the part, we will provide a replacement part or, at our option, credit toward the purchase of a new furnace manufactured by us. This additional Limited Warranty runs only to the original purchaser, and lasts only for as long as the original purchaser lives in the home where the furnace is initially installed.** It is not transferable to any subsequent owner. If the furnace was not installed in the home of the original purchaser, if the original purchaser sells the home to a subsequent owner, or if proof of original purchase cannot be provided, then the limited warranty is only for 20 years from the date of original installation.

Oil Fired Floor Furnace: NFO: A replacement heat exchanger will be provided for any heat exchanger that fails due to defect for 10 years from installation with the following limitation: during the sixth through tenth year, any credit toward your purchase of a component or toward the purchase of any new unit will be in an amount equal to the distributor's purchase price reduced by 20 percent for each year after the fifth year.

ADDITIONAL TERMS FOR OIL FURNACE APPLICATIONS ONLY

- 1) OIL BURNERS - A replacement for 5 years from date of original installation for Oil Burner Parts.
- 2) OPTIONAL ACCESSORIES AND FUNCTIONAL PARTS: A replacement for 5 years from date of original installation. (Refractory and oil nozzles not included)

GAS/ELECTRIC PACKAGED UNITS HEAT EXCHANGERS

Model series: PGAD, PGAA, PGMD, PGME, PGF, GPFM, PGC, GPCM: A replacement for 10 years from original date of installation.

COMPRESSORS:*

1) **Premium Model Units: HAC0, HAC2, HAC4, CAC0, CAC2, CAC4, KAC0, TCA0, TCA2, TCA4, HHP0, HHP2, HHP4, CHP0, CHP2, CHP4, TCH0, TCH2, TCH4, HXA2, CXA2, HXA4, TXA4, CXA4, PGME, PYMC, PHAD, PGAD, PA95, PAPC, PAK, APK:** To the original purchaser a replacement for 10 years from original date of installation, only if the unit is installed with factory matched coils, except air conditioner condensing units with a nominal SEER of 10 may be matched with evaporator coils of the same nominal tonnage regardless of manufacturer and in accordance to factory recommendations. This limited 10-year warranty is not transferable to any subsequent owner. HOWEVER, if the unit was not installed in the home owned by the original purchaser, if the purchaser sells the home to a subsequent owner, or if proof of original purchase cannot be provided, then the limited warranty is only for 5 years from the original date of installation.**

2) **All Other Models: Air Conditioners, Heat Pumps, & Combination Gas/Electric Units: NAC0, NAC2, NHP0, NHP2, AO, A2, HO, H2, PGF, PGC, GPFM, GPCM, PAF, APFM, PHE, HPFM, PGAA, PGMD, PA55, PH55, PAPA, PYPA, PGS, GPSM:** A replacement for 5 years from date of original installation, only if: (a) air conditioner condensing units with SEER rating in the range of 10 to 11 SEER are matched with evaporator coils of the same nominal tonnage regardless of manufacturer and in accordance to factory recommendations, or (b) heat pump condensing units are used with factory matched coils, unless written approval to do otherwise is obtained from manufacturer.

ADDITIONAL TERMS FOR COMMERCIAL PRODUCT OR APPLICATIONS ONLY

For purposes of this warranty a commercial product or application is one in which: the product has over 5 tons nominal cooling capacity, or is designed for operation with 3 phase electrical power, or is installed in a commercial establishment such as a beauty or hair salon, hospital, school, restaurant, church, hotel etc..

3-Phase Models: PGF, GPFM, GPF, PGAD, PGME, PGB, PGMG, PGMF, PGS, GPSM, PGE, APE, PAE, PAB, PAMD, PAS, PAF, APFM, APF, PHB, PHE, PYMD, HPB, PHS, CAC, ACC, CAE, ACE, CHC, HCC, CHE, HCE, CHB, YA:

The additional Terms of the components listed below are in addition to and subject to the General Terms on the reverse side of this page.

- 1) GAS FIRED HEAT EXCHANGERS (ALL MODELS, except PGS, GPSM 3 to 5 Ton):* A replacement for 10 years from date of original installation.
 - a) NOTE: PGS, GPSM 3 to 5 Ton Models:* A replacement for 15 years from date of original installation.
- 2) COMPRESSORS (ALL MODELS):* A replacement for 5 years from date of original installation.
- 3) OPTIONAL ACCESSORIES AND FUNCTIONAL COMPONENT PARTS (ALL MODELS):* A replacement for 1 year from date of original installation.
- 4) COMMERCIAL OIL MODELS: OLR210, OLR350, OTF210, AMT3, AMT4, AMP3: Ten(10) Year Limited Warranty on heat exchangers.

*To receive advantage of your limited warranty, you must provide proof of yearly service by a qualified service agency.

**To receive advantage of your warranty, you must retain the original records that can establish the installation date and proof of purchase of the unit.

MINI SPLITS:

Summary - Mini Splits Warranted for one (1) year on all replacement parts.

Additional terms for Mini Splits:

The additional Terms of the components listed below are in addition to, and subject to, the General Terms on the reverse side of this page.

1) **Compressors (All Models):** A replacement compressor will be provided for all compressors that fail due to defect for 5 years from date of original installation.

2) **Optional Accessories and Functional Components Parts (All Models):**

A replacement part will be provided for all parts that fail due to defect for one (1) year from date of original installation.

Failure to maintain the equipment through annual maintenance by a qualified service agency shall void the warranty. Proof of service will be required with all warranty claims. Proof of purchase and installation date must be submitted with all claims.