

# Installation Instructions

## 80+ 2-Stage & Variable Speed

NTV6/VNE  
NTP6/TNE  
NDP6/TDE

### SAFETY REQUIREMENTS

Recognize safety information. This is the safety-alert symbol . When you see this symbol on the furnace and in instructions manuals be alert to the potential for personal injury.

Understand the signal words *DANGER*, *WARNING*, or *CAUTION*. These words are used with the safety-alert symbol. *DANGER* identifies the most serious hazards, those that **will** result in severe personal injury or death. *WARNING* signifies a hazard that **could** result in personal injury or death. *CAUTION* is used to identify unsafe practices that **could** result in minor personal injury or product and property damage.

Installing and servicing heating equipment can be hazardous due to gas and electrical components. Only trained and qualified personnel should install, repair, or service heating equipment.

Untrained service personnel can perform basic maintenance functions such as cleaning and replacing air filters. All other operations must be performed by trained service personnel. When working on heating equipment, observe precautions in the literature, on tags, and on labels attached to or shipped with the unit and other safety precautions that may apply.

Follow all safety codes. In the United States, follow all safety codes including the current edition National Fuel Gas Code (NFPA No. 54/ANSI Z223.1). In Canada, refer to the current edition of the National Standard Canada CAN/CGA-B149.1- and .2-M91 Natural Gas and Propane Installation Codes (NSCNGPIC). Wear safety glasses and work gloves. Have fire extinguisher available during start-up and adjustment procedures and service calls.

These instructions cover minimum requirements and conform to existing national standards and safety codes. In some instances, these instructions exceed certain local codes and ordinances, especially those that may not have kept up with changing residential construction practices. We require these instructions as a minimum for a safe installation.





Manufactured by:  
*International Comfort Products Corporation (USA)*  
Lewisburg, TN USA 37091

### Table of Contents

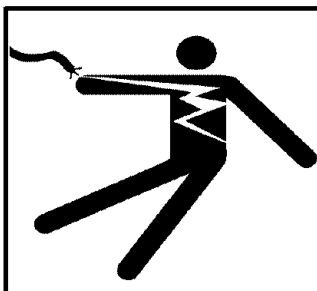
1. Safe Installation Requirements .....	2	7. Electrical Wiring .....	14
2. Installation .....	4	8. Ductwork and Filter (Upflow) .....	16
3. Combustion & Ventilation Air .....	7	9. Ductwork and Filter (Downflow) .....	17
4. Vent and Combustion Air Piping .....	9	10. Checks and Adjustments .....	19
5. Horizontal Venting .....	10	11. Furnace Maintenance .....	21
6. Gas Supply and Piping .....	10	12. Sequence of Operation & Diagnostic .....	21
		13. Tench Support and Parts .....	26



 **DANGER**  
Electric Shock Hazard  
Turn Off All Power Before Servicing.  
Failure to do so can result in death, personal injury and/or property damage.

 **WARNING**  
Fire or Explosion hazard.  
This furnace is not designed for use in mobile homes, trailers or recreational vehicles.  
Such use could result in death, bodily injury and/or property damage.

# 1. Safe Installation Requirements

## **⚠ WARNING**

Installation or repairs made by unqualified persons can result in hazards to you and others. Installation **MUST** conform with local codes or, in the absence of local codes, with codes of all governmental authorities having jurisdiction.

The information contained in this manual is intended for use by a qualified service technician who is experienced in such work, who is familiar with all precautions and safety procedures required in such work, and is equipped with the proper tools and test instruments.

Failure to carefully read and follow all instructions in this manual can result in furnace malfunction, death, personal injury and/or property damage.

**NOTE:** This furnace is design certified by the American Gas Association and the Canadian Gas Association for installation in the United States and Canada. Refer to the appropriate codes, along with this manual, for proper installation.

- This furnace is **NOT** approved for installation in mobile homes, trailers or recreation vehicles.
- Do **NOT** use this furnace as a construction heater or to heat a building that is under construction.
- Use only the Type of gas approved for this furnace (see **Rating Plate** on unit). Overfiring will result in failure of heat exchanger and cause dangerous operation. (Furnace can be converted to L.P. gas with approved kit.)
- Do **NOT** use open flame to test for gas leak.
- Ensure adequate combustion and ventilation air is provided to the furnace.
- Seal supply and return air ducts.
- The vent system **MUST** be checked to determine that it is the correct type and size.
- Install correct filter type and size.
- Unit **MUST** be installed so electrical components are protected from direct contact with water.

## Safety Rules

Your unit is built to provide many years of safe and dependable service providing it is properly installed and maintained. However, abuse and/or improper use can shorten the life of the unit and create hazards for you, the owner.

- A. The U.S. Consumer Product Safety Commission recommends that users of gas-burning appliances install carbon monoxide detectors. There can be various sources of carbon monoxide in a building or dwelling. The sources could be gas-fired clothes dryers, gas cooking stoves, water heaters, furnaces, gas-fired fireplaces, wood fireplaces, and several other items. Carbon monoxide can cause serious bodily injury and/or death. Therefore, to help alert people of potentially dangerous carbon monoxide levels, you should have carbon monoxide detectors listed by a nationally recognized agency (e.g. Underwriters Laboratories or International Approval Services) installed and maintained in the building or dwelling (see Note below).

- B. There can be numerous sources of fire or smoke in a building or dwelling. Fire or smoke can cause serious bodily injury, death, and/or property damage. Therefore, in order to alert people of potentially dangerous fire or smoke, you should have fire extinguisher and smoke detectors listed by Underwriters Laboratories installed and maintained in the building or dwelling (see Note below).

**Note:** The manufacturer of your furnace does not test any detectors and makes no representations regarding any brand or type of detector.

- C. To ensure safe and efficient operation of your unit, you should do the the following:

1. **Thoroughly read this manual and labels on the unit.** This will help you understand how your unit operates and the hazards involved with gas and electricity.
2. **Do not use this unit if any part has been under water.** Immediately call a qualified service technician to inspect the unit and to replace any part of the control system and any gas control which has been under water.
3. **Never obstruct the vent grilles, or any ducts that provide air to the unit.** Air must be provided for proper combustion and ventilation of flue gases.

Carbon monoxide or "CO" is a colorless and odorless gas produced when fuel is not burned completely or when the flame does not receive sufficient oxygen.

## Freezing Temperatures and Your Structure

### **⚠ WARNING**

Freeze warning.

Turn off water system.

If your unit remains shut off during cold weather the water pipes could freeze and burst, resulting in serious water damage.

Your unit is equipped with safety devices that may keep it from operating if sensors detect abnormal conditions such as clogged exhaust flues.

If the structure will be unattended during cold weather you should take these precautions.

1. Turn off main supply water into the structure and drain the water lines if possible. Open faucets in appropriate areas.
2. Have someone check the structure frequently during cold weather to make sure it is warm enough to prevent pipes from freezing. Suggest they call a qualified service agency, if required.

# START-UP CHECK SHEET

(Keep this page for future reference)

Dealer Name: \_\_\_\_\_

Address: \_\_\_\_\_

City, State(Province), Zip or Postal Code: \_\_\_\_\_

Phone: \_\_\_\_\_

Owner Name: \_\_\_\_\_

Address: \_\_\_\_\_

City, State(Province), Zip or Postal Code: \_\_\_\_\_

Model Number: \_\_\_\_\_

Serial Number: \_\_\_\_\_

Type of Gas: Natural:  LP:

Blower Motor H.P.: \_\_\_\_\_

Supply Voltage: \_\_\_\_\_

Which blower (DIP switch) setting is used?

Heating \_\_\_\_\_ Cooling \_\_\_\_\_ Continuous \_\_\_\_\_

Temperature of Supply Air: High Fire (°F) \_\_\_\_\_ or (°C) \_\_\_\_\_  
Low Fire (°F) \_\_\_\_\_ or (°C) \_\_\_\_\_

Temperature of Return Air: (°F) \_\_\_\_\_ or (°C) \_\_\_\_\_

Temp. Rise Hi Fire (Supply - Return): (°F) \_\_\_\_\_ or (°C) \_\_\_\_\_  
Lo Fire (Supply - Return): (°F) \_\_\_\_\_ or (°C) \_\_\_\_\_

Filter Type and Size: \_\_\_\_\_

Fan "Time ON" Setting: \_\_\_\_\_

Fan "Time OFF" Setting: \_\_\_\_\_

Dealer Comments: \_\_\_\_\_

\_\_\_\_\_

\_\_\_\_\_

\_\_\_\_\_

Business Card Here

Manual Gas Shut-Off Upstream

of Furnace/Drip-Leg? YES  NO

Drip-Leg Upstream of Gas Valve? YES  NO

Blower Speed Checked? YES  NO

All Electrical Connections Tight? YES  NO

Electrical Polarity Checked? YES  NO

Furnace Properly Grounded? YES  NO

Gas Valve Status Light OK? YES  NO

Gas Valve Turned ON? YES  NO

Measured Line Pressure When Firing Unit: \_\_\_\_\_

Calculated Firing Rate: (High & Low Fire) (See *Checks and Adjustments* Section). \_\_\_\_\_

Measured Manifold Pressure: Hi Fire \_\_\_\_\_ Lo Fire \_\_\_\_\_

Thermostat OK? YES  NO

Thermostat: Single Stage \_\_\_\_\_ Two Stage \_\_\_\_\_

Subbase Level? YES  NO

Anticipator Set? YES  NO  Set At?: \_\_\_\_\_

Breaker On? YES  NO

Date of Installation: \_\_\_\_\_

Date of Start-Up: \_\_\_\_\_

## 2. Installation

### **⚠ WARNING**

Poison carbon monoxide gas hazard.

If this furnace is replacing a previously common-vented furnace, it may be necessary to resize the existing vent line and chimney to prevent oversizing problems for the other remaining appliances(s). See applicable codes and *Venting and Combustion Air Check* in *Gas Vent Installation* section.

Failure to properly vent this furnace or other appliances can result in death, personal injury and/or property damage.

### Location and Clearances

If furnace is a replacement, it is usually best to install the furnace where the old one was. Choose the location or evaluate the existing location based upon the minimum clearance and furnace dimensions (Figure 1, Figure 2 or Figure 3).

### CAUTION

Do NOT operate furnace in a corrosive atmosphere containing chlorine, fluorine or any other damaging chemicals. Refer to *Combustion & Ventilation Air* section, *Contaminated Combustion Air*.

Figure 1

Dimensions and Clearances (NTV6/VNE)

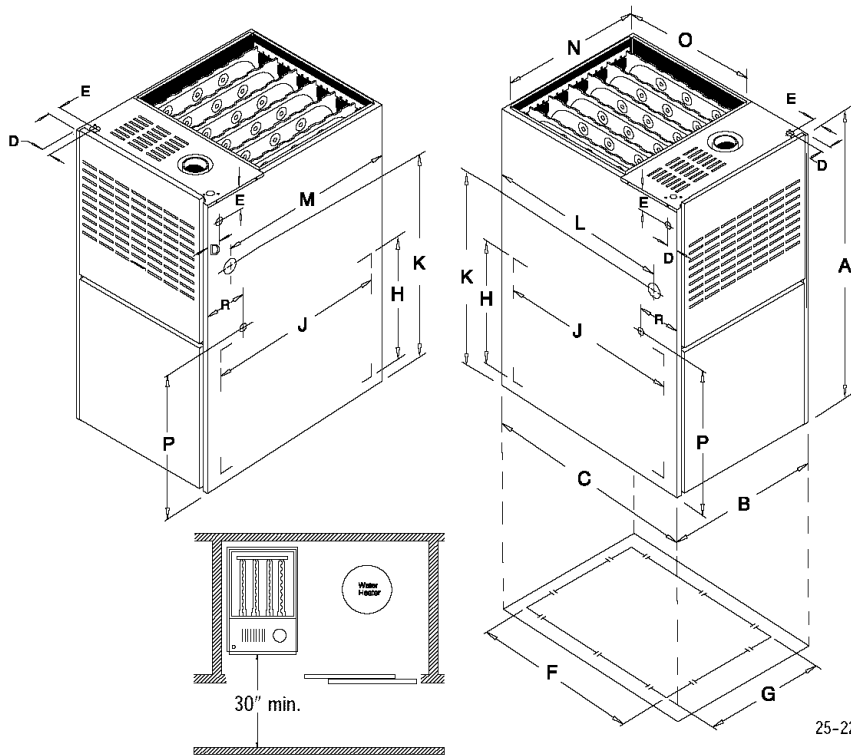

MINIMUM CLEARANCES TO COMBUSTIBLE MATERIALS FOR ALL UNITS	
REAR	0
FRONT	3"
Recommended For Service	30"
ALL SIDES OF SUPPLY PLENUM	1"
SIDES	0
VENT	
Single Wall Vent	6"
Type B-1 Double Wall Vent	1"
TOP OF FURNACE	1"

**NOTE:** Evaporator "A" coil drain pan dimensions may vary from furnace duct opening size. Always consult evaporator specifications for duct size requirements.

Unit is designed for bottom return or side return.

Return air through back of unit is NOT allowed.

25-22-28

### DIMENSIONAL INFORMATION

Unit Capacity	Cabinet			Electrical Connections						Supply Air		Return Air				Gas Connections			
				Top		Left/Right Side		Low Volt				Bottom		Side		Right Side		Left Side	
	A	B	C	D	E	D	E	R	P	O	N	F	G	J	H	M	K	L	K
050FB/050B12	40	15 <sup>1</sup> / <sub>2</sub>	28 <sup>1</sup> / <sub>2</sub>	1 <sup>1</sup> / <sub>2</sub>	1 <sup>1</sup> / <sub>2</sub>	1 <sup>1</sup> / <sub>2</sub>	1 <sup>1</sup> / <sub>2</sub>	4 <sup>1</sup> / <sub>2</sub>	17 <sup>5</sup> / <sub>16</sub>	18 <sup>1</sup> / <sub>2</sub>	14	23 <sup>1</sup> / <sub>8</sub>	12 <sup>5</sup> / <sub>8</sub>	22 <sup>1</sup> / <sub>2</sub>	12 <sup>1</sup> / <sub>4</sub>	23 <sup>7</sup> / <sub>8</sub>	28 <sup>1</sup> / <sub>4</sub>	26	28 <sup>1</sup> / <sub>4</sub>
075GF/075F14	40	19 <sup>1</sup> / <sub>8</sub>	28 <sup>1</sup> / <sub>2</sub>	1 <sup>1</sup> / <sub>2</sub>	1 <sup>1</sup> / <sub>2</sub>	1 <sup>1</sup> / <sub>2</sub>	1 <sup>1</sup> / <sub>2</sub>	4 <sup>1</sup> / <sub>2</sub>	17 <sup>5</sup> / <sub>16</sub>	18 <sup>1</sup> / <sub>2</sub>	17 <sup>5</sup> / <sub>8</sub>	23 <sup>1</sup> / <sub>8</sub>	14 <sup>3</sup> / <sub>4</sub>	22 <sup>1</sup> / <sub>2</sub>	14 <sup>1</sup> / <sub>2</sub>	23 <sup>7</sup> / <sub>8</sub>	28 <sup>1</sup> / <sub>4</sub>	26	28 <sup>1</sup> / <sub>4</sub>
100KJ & 125KJ 100J20 & 125J20	40	22 <sup>3</sup> / <sub>4</sub>	28 <sup>1</sup> / <sub>2</sub>	1 <sup>1</sup> / <sub>2</sub>	1 <sup>1</sup> / <sub>2</sub>	1 <sup>1</sup> / <sub>2</sub>	1 <sup>1</sup> / <sub>2</sub>	4 <sup>1</sup> / <sub>2</sub>	17 <sup>5</sup> / <sub>16</sub>	18 <sup>1</sup> / <sub>2</sub>	21 <sup>1</sup> / <sub>4</sub>	23 <sup>1</sup> / <sub>8</sub>	18 <sup>3</sup> / <sub>4</sub>	22 <sup>1</sup> / <sub>2</sub>	14 <sup>1</sup> / <sub>2</sub>	23 <sup>7</sup> / <sub>8</sub>	28 <sup>1</sup> / <sub>4</sub>	26	28 <sup>1</sup> / <sub>4</sub>

ALL DIMENSIONS IN INCHES

Figure 2

Dimensions and Clearances (NTP6/TNE)

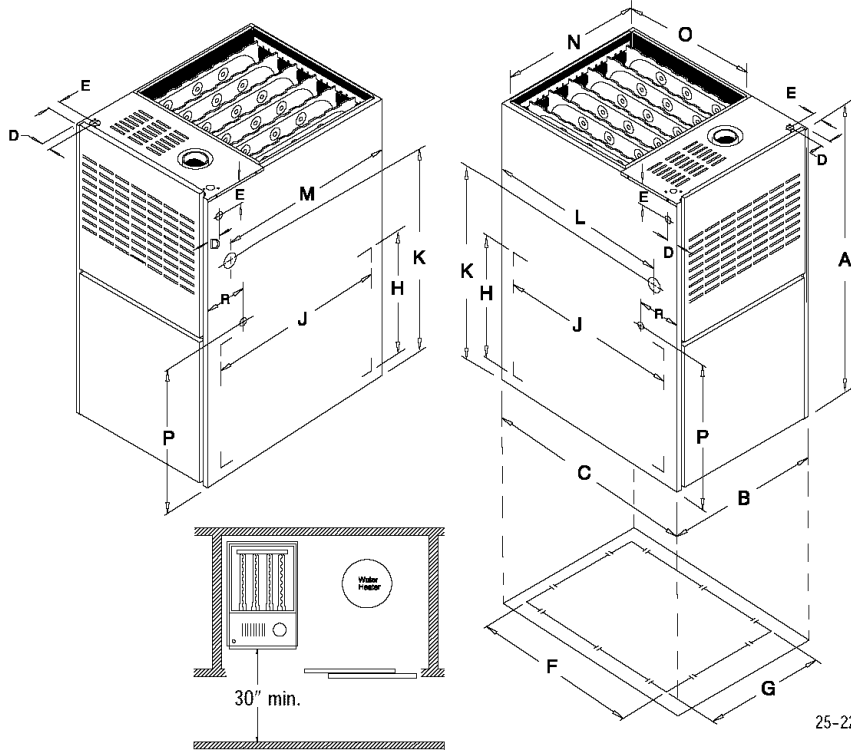

MINIMUM CLEARANCES TO COMBUSTIBLE MATERIALS FOR ALL UNITS	
REAR	0
FRONT	3"
Recommended for Service	30"
ALL SIDES OF SUPPLY PLENUM	1"
SIDES	0
VENT	
Single Wall Vent	6"
Type B-1 Double Wall Vent	1"
TOP OF FURNACE	1"

**NOTE:** Evaporator "A" coil drain pan dimensions may vary from furnace duct opening size. Always consult evaporator specifications for duct size requirements.

Unit is designed for bottom return or side return. Return air through back of unit is NOT allowed.

25-22-28

DIMENSIONAL INFORMATION

Unit Capacity	Cabinet			Electrical Connections						Supply Air		Return Air				Gas Connections			
				Top		Left/Right Side		Low Volt				Bottom		Side		Right Side		Left Side	
	A	B	C	D	E	D	E	R	P	O	N	F	G	J	H	M	K	L	K
NTP6050FB TNE050B12	40	15 <sup>1</sup> / <sub>2</sub>	28 <sup>1</sup> / <sub>2</sub>	1 <sup>1</sup> / <sub>2</sub>	1 <sup>1</sup> / <sub>2</sub>	1 <sup>1</sup> / <sub>2</sub>	1 <sup>1</sup> / <sub>2</sub>	4 <sup>1</sup> / <sub>2</sub>	17 <sup>5</sup> / <sub>16</sub>	18 <sup>1</sup> / <sub>2</sub>	14	23 <sup>1</sup> / <sub>8</sub>	12 <sup>5</sup> / <sub>8</sub>	22 <sup>1</sup> / <sub>2</sub>	12 <sup>1</sup> / <sub>4</sub>	23 <sup>7</sup> / <sub>8</sub>	28 <sup>1</sup> / <sub>4</sub>	26	28 <sup>1</sup> / <sub>4</sub>
NTP6075GF TNE075F14 NTP6100GF TNE100F14	40	19 <sup>1</sup> / <sub>8</sub>	28 <sup>1</sup> / <sub>2</sub>	1 <sup>1</sup> / <sub>2</sub>	1 <sup>1</sup> / <sub>2</sub>	1 <sup>1</sup> / <sub>2</sub>	1 <sup>1</sup> / <sub>2</sub>	4 <sup>1</sup> / <sub>2</sub>	17 <sup>5</sup> / <sub>16</sub>	18 <sup>1</sup> / <sub>2</sub>	17 <sup>5</sup> / <sub>8</sub>	23 <sup>1</sup> / <sub>8</sub>	14 <sup>3</sup> / <sub>4</sub>	22 <sup>1</sup> / <sub>2</sub>	14 <sup>1</sup> / <sub>2</sub>	23 <sup>7</sup> / <sub>8</sub>	28 <sup>1</sup> / <sub>4</sub>	26	28 <sup>1</sup> / <sub>4</sub>
NTP6100HKJ TNE100J20 NTP6125KJ TNE125J20	40	22 <sup>3</sup> / <sub>4</sub>	28 <sup>1</sup> / <sub>2</sub>	1 <sup>1</sup> / <sub>2</sub>	1 <sup>1</sup> / <sub>2</sub>	1 <sup>1</sup> / <sub>2</sub>	1 <sup>1</sup> / <sub>2</sub>	4 <sup>1</sup> / <sub>2</sub>	17 <sup>5</sup> / <sub>16</sub>	18 <sup>1</sup> / <sub>2</sub>	21 <sup>1</sup> / <sub>4</sub>	23 <sup>1</sup> / <sub>8</sub>	18 <sup>3</sup> / <sub>4</sub>	22 <sup>1</sup> / <sub>2</sub>	14 <sup>1</sup> / <sub>2</sub>	23 <sup>7</sup> / <sub>8</sub>	28 <sup>1</sup> / <sub>4</sub>	26	28 <sup>1</sup> / <sub>4</sub>

ALL DIMENSIONS IN INCHES

Figure 3

Dimensions and Clearances (NDP6/TDE)

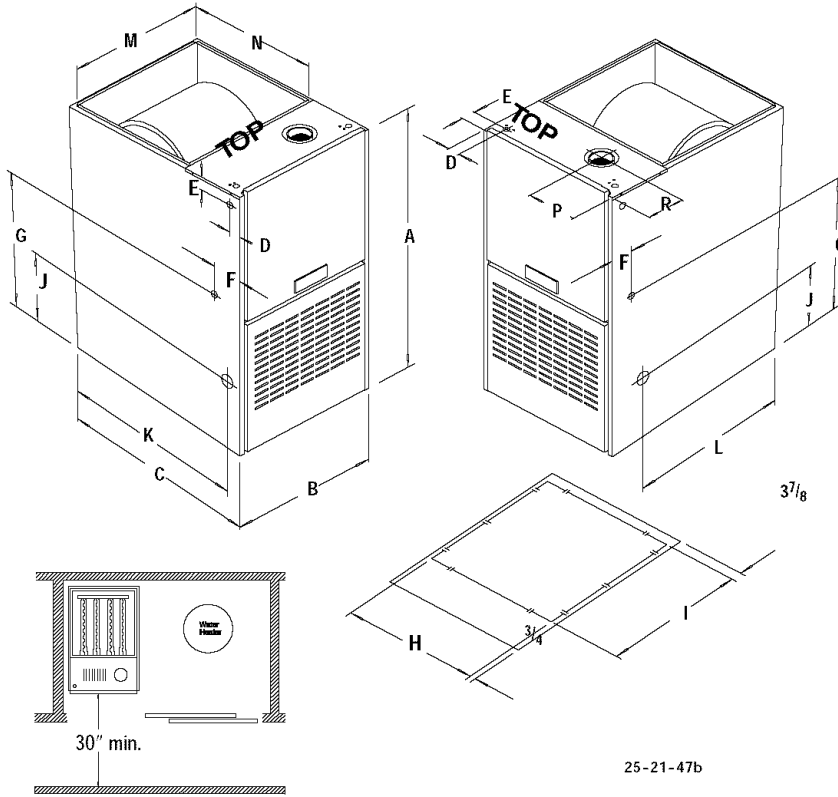

MINIMUM CLEARANCES TO COMBUSTIBLE MATERIALS FOR ALL UNITS	
REAR	0
FRONT	3"
Recommended For Service	30"
ALL SIDES OF SUPPLY PLENUM	1"
SIDES	0
VENT	
Single Wall Vent	6"
Type B-1 Double Wall Vent	1"
TOP OF FURNACE	1"

DIMENSIONAL INFORMATION

Unit Dimensions	Cabinet			Electrical Connections								Supply	
				Top		Left Side		Low Voltage					
	A	B	C	D	E	D	E	Right		Left		H	I
								(F)	(G)	(F)	(G)		
NDP6050/075FB TDE050/075B12	40	15 1/2	28 1/2	1 1/2	1 1/2	1 5/8	1 1/2	3 15/16	25 3/4	3 13/16	24 3/4	14	16 5/8
NDP6100HF TDE100F16	40	19 1/8	28 1/2	1 1/2	1 1/2	1 5/8	1 1/2	3 15/16	17 5/8	3 13/16	25 3/4	17 5/8	16 5/8
NDP6125KJ TDE125J20	40	22 3/4	28 1/2	1 1/2	1 1/2	1 5/8	1 1/2	3 15/16	21 1/4	3 13/16	25 3/4	21 1/4	16 5/8

Unit Dimensions	Gas Connections			Return		Flue	
	J	K	L	M	N	P	R
NDP6050/075FB TDE050/075B12	9 1/2	26 1/16	23 7/8	14	18 1/2	3 7/8	5 1/4
NDP6100HF TDE100F16	9 1/2	26 1/16	23 7/8	17 5/8	18 1/2	5 5/16	5 1/4
NDP6125KJ TDE125J20	9 1/2	26 1/16	23 7/8	21 1/4	18 1/2	7 1/2	5 1/4

ALL DIMENSIONS IN INCHES

Installation Requirements

1. Install furnace level.
2. Install furnace as centralized as practical with respect to the heat distribution system.
3. Install the vent pipes as short as practical. (See *Gas Vent Installation* section).
4. Do **NOT** install furnace directly on carpeting, tile or other combustible material other than wood flooring.
5. Maintain clearance for fire safety and servicing. A front clearance of 30" is minimum for access to the burner, controls and filter.

**⚠ WARNING**

**Fire Hazard.**  
Place furnace on noncombustible cement board or sheet metal on downflow applications.  
Failure to install unit on noncombustible cement board or sheet metal can result in death and/or personal injury and/or property damage.

6. Use a raised base if the floor is damp or wet at times.

7. Residential garage installations require:
  - Burners and ignition sources installed at least 18" (457mm) above the floor.
  - Furnace must be located or physically protected from possible damage by a vehicle.

## Horizontal Furnace Installation

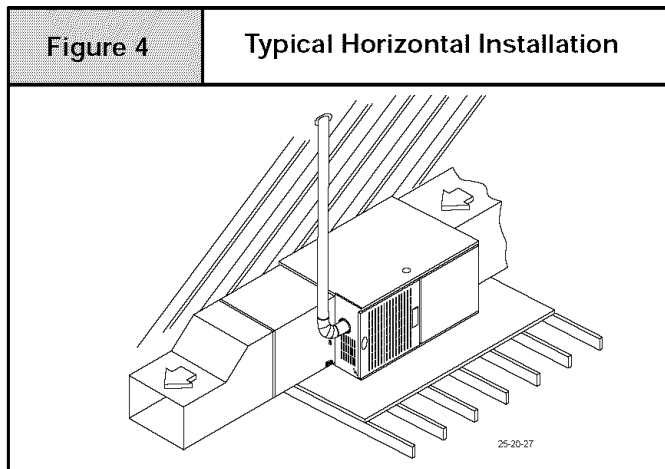

### IMPORTANT

**NOTE:** Inspect unit rating plate to be certain model number begins with "NTV6", "NTP6", "VNE" or "TNE". This identifies unit as horizontally mountable. If unit does **NOT** bear this designation, you may **NOT** mount this unit horizontally. **Horizontal furnace may not be mounted on its back.**

## 3. Combustion & Ventilation Air

**⚠ WARNING**

Poison carbon monoxide gas hazard.  
Use methods described here to provide combustion and ventilation air.  
Failure to provide adequate combustion and ventilation air can result in death and/or personal injury.

Furnaces require ventilation openings to provide sufficient air for proper combustion and ventilation of flue gases. All duct or openings for supplying combustion and ventilation air must comply with the gas codes, or in the absence of local codes, the applicable national codes.

When the installation is complete, check that all appliances have adequate combustion air and are venting properly. See *Venting And Combustion Air Check* in Section 4 of this manual.

### Contaminated Combustion Air

Installations in certain areas or types of structures will increase the exposure to chemicals or halogens that may harm the furnace. These instances must use only outside air for combustion.

The following areas or types of structures may contain or have exposure to the substances listed below. The installation must be evaluated carefully as it may be necessary to provide outside air for combustion.

- Commercial buildings.
- Buildings with indoor pools.
- Furnaces installed in laundry rooms.
- Furnaces installed in hobby or craft rooms.

If you purchased a horizontally mountable furnace, it can be installed horizontally in an attic, basement, crawl space, alcove, or suspended from a ceiling in a basement or utility room in either a right or left airflow position. See **Figure 4**.

The following minimum clearances to combustibles **MUST** be maintained between the furnace and adjacent construction, as shown in **Figure 4**. **ONLY** the corner of the cabinet is allowed to contact the rafters. All other clearances should be observed as shown in **Figure 1**, **Figure 2**, or **Figure 3**.

If the furnace is to be suspended from the floor joists in a crawl space or the rafters in an attic, it is necessary to use steel pipe straps or an angle iron frame to attach the furnace. These straps should be attached to the furnace with sheet metal screws and to the rafters or joists with bolts. The preferred method is to use an angle iron frame bolted to the rafters or joists.

Thirty inches (30") is recommended between the front of the furnace and adjacent construction or other appliances. This should be maintained for service clearance.

Keep all insulating materials clear from louvered door. Insulating materials may be combustible.

It is recommended for further fire protection that cement board or sheet metal is placed between the furnace and the combustible wood floor and extend 12" (300mm) beyond the front of the furnace louver door. (This is a recommendation only, not a requirement).

This furnace **MUST NOT** be installed directly on carpeting or tile or other combustible material other than wood flooring or supports.

- Furnaces installed near chemical storage areas.
- Permanent wave solutions for hair.
- Chlorinated waxes and cleaners.
- Chlorine based swimming pool chemicals.
- Water softening chemicals.
- De-icing salts or chemicals.
- Carbon tetrachloride.
- Halogen type refrigerants.
- Cleaning solvents (such as perchloroethylene).
- Printing inks, paint removers, varnishes, etc..
- Hydrochloric acid.
- Sulfuric Acid.
- Solvent cements and glues.
- Antistatic fabric softeners for clothes dryers.
- Masonry acid washing materials.

### Confined Space Installation

**NOTE:** A confined space is defined as an area with less than 50 cubic feet(1.4m<sup>3</sup>) per 1,000 BTUH input rating for all gas appliances installed in the area.

### Air Openings and Connecting Ducts

1. Total input rating for all gas appliances **MUST** be considered when determining free area of openings.
2. Connect ducts or openings directly to outside.
3. When screens are used to cover openings, the openings **MUST** be no smaller than 1/4" (6mm) mesh.
4. The minimum dimension of rectangular air ducts **MUST NOT** be less than 3" (75mm).

- When sizing grille or louver, use the free area of opening. If free area is **NOT** stamped or marked on grill or louver, assume a 20% free area for wood and 60% for metal.

## Requirements

- Provide confined space with sufficient air for proper combustion and ventilation of flue gases using horizontal or vertical ducts or openings.

- Figure 5** illustrates how to provide combustion and ventilation air. A minimum of two permanent openings, one inlet and one outlet, are required.

- One opening **MUST** be within 12" of the floor and the second opening within 12" of the ceiling.

- Size openings and ducts per **Table 1**.

**Figure 5** Outside Air (This is ONLY a guide. Subject to codes of country having jurisdiction.)

This installation NOT approved in Canada

Minimum One Inlet and One Outlet Air Supply is Required  
May be in and Combination Shown

Inlet Air Opening Must be Within 12" (300mm) of floor  
Outlet Air Opening Must be Within 12" (300mm) of ceiling

(1) 1 Square Inch (6cm<sup>2</sup>) per 4000 BTUH  
(2) 1 Square Inch (6cm<sup>2</sup>) per 2000 BTUH

- Horizontal duct openings require 1 square inch of free area per 2,000 BTUH of combined input for all gas appliances in area (see **Table 1**).
- Vertical duct openings or openings directly to outside require 1 square inch of free area per 4,000 BTUH for combined input of all gas appliances in area (see **Table 1**).

One permanent opening, commencing within 12" of the top of the enclosure, shall be permitted where the equipment has clearances of at least 1" from the sides and back and 6" (16 cm.) from the front of the appliance. The opening shall directly communicate with the outdoors or shall communicate through a vertical or horizontal duct to the outdoors or spaces (crawl or attic) that freely communicate with the outdoors, and shall have a minimum free area of:

- 1 sq. in per 3000 Btu per hr of the total input rating of all equipment located in the enclosure, and
- Not less than the sum of the areas of all vent connectors in the confined space.

## Unconfined Space Installation

**WARNING**

Poison carbon monoxide gas hazard.  
Most homes will require additional air.  
An unconfined space or homes with tight construction may not have adequate air infiltration for proper combustion and ventilation of flue gases.  
Failure to supply additional air by means of ventilation grilles or ducts could result in death and/or personal injury.

Table 1		Free Area	
BTUH Input Rating	Minimum Free Area Required for Each Opening		
	Horizontal Duct (sq. in./2,000 BTUH)	Vertical Duct or openings to outside (sq. in./4,000 BTUH)	Rd Duct (sq. in./4,000 BTUH)
50,000	25 sq. in.	12.5 sq. in.	4"
75,000	37.5 sq. in.	18.75 sq. in.	5"
100,000	50 sq. in.	25 sq. in.	6"
125,000	62.5 sq. in.	31.25 sq. in.	7"

**EXAMPLE: Determining Free Area**

Furnace Water Heater Total Input  
100,000 + 30,000 = (130,000 ÷ 4,000) = 32.5 Sq. In. Vertical

Furnace Water Heater Total Input  
100,000 + 30,000 = (130,000 ÷ 2,000) = 65 Sq. In. Horizontal

An unconfined space is defined as an area having a minimum volume of 50 cubic feet per 1,000 BTUH total input rating for all gas appliances in area.

Adjoining rooms can be considered part of an unconfined area if there are no doors between rooms.

An attic or crawl space may be considered an unconfined space provided there are adequate ventilation openings directly to outdoors. Openings **MUST** remain open and **NOT** have any means of being closed off. Ventilation openings to outdoors **MUST** be at least 1 square inch of free area per 4,000 BTUH of total input rating for all gas appliances in area.

In unconfined spaces, infiltration should be adequate to provide air for combustion, ventilation and dilution of flue gases. However, in buildings with unusually tight construction, additional air **MUST** be provided using the methods described in section titled *Confined Space Installation*.



Unusually tight construction is defined as: Construction with

- 1 Walls and ceilings exposed to the outside have a continuous, sealed vapor barrier. Openings are gasketed or sealed and
- 2 Doors and openable windows are weather stripped and
3. Other openings are caulked or sealed. These include joints around window and door frames, between sole plates and floors, between wall-ceiling joints, between wall panels, at penetrations for plumbing, electrical and gas lines, etc.

## 4. Gas Vent Installation

### ⚠ WARNING

Poison carbon monoxide gas, fire and explosion hazard.

Read and follow all instructions in this section.

Failure to properly vent this furnace can result in death, personal injury and/or property damage.

Install the vent in compliance with codes of the country having jurisdiction, local codes or ordinances and these instructions.

These fan assisted combustion furnaces have been classified as Category I appliances which means that they **MUST** operate with a negative vent pressure.

### Category I Safe Venting Requirements

**NOTE:** The following instructions comply with the United States National Fuel Gas Code. Based on the highest input rate on the furnace rating plate.

1. If a Category I vent passes through an attic, any concealed space or floor, use **ONLY** Type B or Type L double wall vent pipe. If vent pipe passes through interior wall, use type B vent pipe with ventilated thimble **ONLY**.
2. Do **NOT** vent furnace into any chimney serving an open fireplace or solid fuel burning appliance.
3. Use the same diameter Category I connector or pipe as permitted by the **United States National Fuel Gas Code** venting tables.
4. Keep vertical Category I vent pipe or vent connector runs as short and direct as possible.
5. Vertical outdoor runs of type B or **ANY** single wall vent pipe below the roof line are **NOT** permitted.
6. Slope all horizontal runs up away from furnace a minimum of  $\frac{1}{4}$ " per foot.
7. Support all horizontal vent pipe every 6' using proper clamps and metal straps.
8. Check existing gas vent or chimney to ensure they meet clearances and local codes.
9. The furnace **MUST** be connected to a factory built chimney or vent complying with a recognized standard. **Venting into a masonry or concrete chimney is only permitted as outlined in the United States National Fuel Gas Code venting tables or *Masonry Chimney* section in these instructions.**

## Ventilation Air

Some provincial codes and local municipalities require ventilation or make-up air be brought into the conditioned space as replacement air. Whichever method is used, the mixed return air temperature across the heat exchanger **MUST** not fall below 60°F or flue gases will condense in the heat exchanger. This will shorten the life of the heat exchanger and possibly void your warranty.

### ⚠ WARNING

Poison carbon monoxide gas hazard.

If this furnace is replacing a previously common-vented furnace, it may be necessary to resize the existing chimney liner or vent to prevent over sizing problems for the other remaining appliances(s). See codes of country having jurisdiction.

Failure to properly vent this furnace or other appliances can result in death, personal injury and/or property damage.

## Venting and Combustion Air Check

**NOTE:** If this installation removes an existing furnace from a venting system serving one or more other appliances, and to make sure there is adequate combustion air for all appliances, **MAKE THE FOLLOWING CHECK.**

1. Seal any unused openings in the venting system.
2. Visually inspect the venting system for proper size and horizontal pitch to ensure there is no blockage or restriction, leakage, corrosion or other deficiencies which could cause an unsafe condition.
3. Insofar as is practical, close all doors and windows and all doors between the space in which the appliance(s) remaining connected to the venting system are located and other spaces of the building.
4. Turn on clothes dryers and any appliance not connected to the venting system. Turn on any exhaust fans, such as range hoods and bathroom exhausts, so they will operate at maximum speed. Do not operate a summer exhaust fan. Close fireplace dampers.
5. Follow the lighting instructions for each appliance being inspected. Adjust thermostat so appliance(s) will operate continuously.
6. Allow 5 minutes of main burner operation, then check for spillage at the draft hood relief opening of each appliance. Use the flame of a match or candle (**Figure 6**).

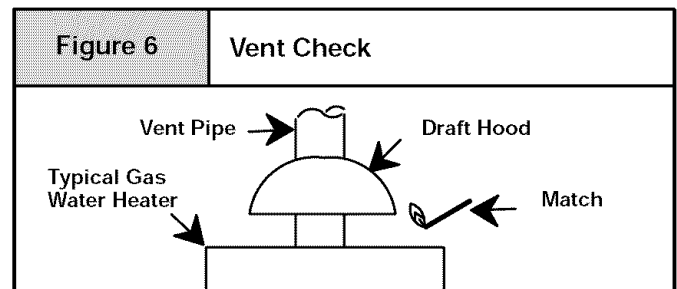

7. After it has been determined that each appliance vents properly, return doors, windows, appliances etc. to their normal condition.

- 8. If improper venting is observed, the cause **MUST** be corrected.

**NOTE:** If flame pulls towards draft hood, this indicates sufficient infiltration air.

## Venting to Existing Masonry Chimney

**NOTE:** The tables and notes referred to below are found in the most recent printing of the **United States National Fuel Gas Code** venting tables.

Use the United States National Fuel Gas Code or NFGC Tables to size the chimney or vent. **Dedicated venting of one fan assisted furnace into any masonry chimney is restricted.** The chimney must first be lined with either type B vent sized in accordance with tables 1 or 2 or a listed single wall, metal lining system, sized in accordance with the vent tables.

## 5. Horizontal Venting

### Category I Furnaces With External Power Venters

In order to maintain a Category I classification of fan assisted furnaces when vented horizontally with sidewall termination, a power venter is **REQUIRED** to maintain a negative pressure in the venting system. Please consult the Fields Controls Co. or Tjernlund Products, Inc. for power Venters certified for use with our furnaces.

#### Vent Termination

#### Venting Through a Non-Combustible and Combustible Wall

Consult External Power Venter manufacturer instructions.

## 6. Gas Supply and Piping

**⚠ WARNING**

Poison carbon monoxide gas hazard.  
 Models designated for Natural Gas are to be used with Natural Gas **ONLY**, unless properly converted to use with LP gas.  
 Failure to follow these instructions can result in death, personal injury and/or property damage.

### Gas Supply Requirements

- Use only the Type of gas approved for this furnace. See rating plate for approved gas type.
- Gas input must not exceed the rated input shown on the rating plate. Overfiring will result in failure of heat exchanger and cause dangerous operation.
- Do not allow minimum supply pressure to vary downward. Doing so will decrease input to furnace. Refer to **Table 2** for Gas supply and manifold pressures.

Listed, corrugated metallic chimney liner systems in masonry chimneys shall be sized by using **United States National Fuel Gas Code** tables for dedicated venting and **United States National Fuel Gas Code** tables for common venting with the maximum capacity reduced by 20% (0.80 X maximum capacity) and the minimum capacity as shown in the applicable table. Corrugated metal vent systems installed with bends or offsets require additional reduction of 10% of the vent capacity for each 90° elbow.

**NOTE:** Two(2) 45° elbows are equivalent to one (1) 90° elbow.

### Combined Venting into a Masonry Chimney

Venting into a masonry or concrete chimney is only permitted as outlined in the **United States National Fuel Gas Code** venting tables. Follow all safe venting requirements.

### CAUTION

It is the responsibility of the installer to properly terminate the vent and provide adequate shielding. This is essential in order to avoid water/ice damage to building, shrubs and walk-ways.

Table 2		Gas Pressures			
Gas Type	Supply Pressure			Manifold Pressure	
	Recommended	Max.	Min.	High	Low
Natural	7" (1.7 kPa)	14" (3.5 kPa)	4.5" (1.1 kPa)	3.5" (0.9 kPa)	1.7" (0.42 kPa)
Propane	11" (2.7 kPa)	14" (3.5 kPa)	11" (2.7 kPa)	10" (2.5 kPa)	4.3" (1.07 kPa)

### Manifold Gas Pressure Adjustments (Hi & Lo Fire)

**NOTE:** Gas supply pressure **MUST** be within minimum and maximum values listed on rating plate. Pressures are usually set by gas suppliers.

Make adjustment to manifold pressure with burners operating and combustion air box cover removed.

1. Remove combustion air box cover.
2. Connect manometer to the tapped opening on the outlet side of gas valve or on the manifold pipe. Use a manometer with a 0 to 12" minimum water column range.
3. Turn gas **ON**. Operate the furnace on high fire by using a jumper wire on the R to W1 & W2 thermostat connections on the fan board.

4. Remove the adjustment cover on the gas valve. Turn adjusting screw counterclockwise to decrease the manifold pressure and clockwise to increase. See **Figure 29**.
5. Set the manifold pressure to value shown in **Table 2**, **Table 3** or **Table 4**.
6. Operate the furnace on low fire by using a jumper wire on the R to W1 thermostat connections on the fan board.  
**Note:** The fourth (4th) DIP switch should be in the on position to set the low fire manifold pressure. (See wiring diagram)
7. Repeat steps 4 and 5 for low fire operation.
8. When the manifold pressures are properly set, replace the adjustment screw covers on the gas valve.
9. Remove the jumper wires from the thermostat connections on the fan board. Remove manometer and replace plug in manifold.
10. Replace combustion air box cover.
11. Return fourth (4th) DIP switch to previous setting.

### Natural Gas Input Rating Check

**NOTE:** The gas meter can be used to measure input to furnace. Rating is based on a natural gas BTU content of 1,000 BTU's per cubic meter. Check with gas supplier for actual BTU content.

1. Make sure combustion air box cover is in place and closed before performing the following steps.
2. Turn **OFF** gas supply to all appliances and start furnace. Use jumper wire on R to W1 and W2 for Hi fire.
3. Time how many seconds it takes the smallest dial on the gas meter to make one complete revolution. Refer to **Example**.
4. Repeat steps 2 and 3 with jumper wire on **R** to **W1** for low fire. **NOTE:** Fourth (4th) DIP switch must be in on position. (See furnace wiring diagram). Return fourth (4th) DIP switch to previous setting after check.

Example			
Natural Gas BTU Content	No. of Seconds Per Hour	Time Per Cubic Foot in Seconds	BTU Per Hour
1,000	3,600	48	75,000
$1,000 \times 3,600 \div 48 = 75,000 \text{ BTUH}$			

**NOTE:** If meter uses a 2 cubic foot dial, divide results (seconds) by two.

5. Relight all appliances and ensure all pilots are operating.

### Orifice Sizing

**NOTE:** Factory sized orifices for natural and LP gas are listed in the furnace Technical Support manual.

Ensure furnace is equipped with the correct main burner orifices. Refer to **Table 3** & **Table 4** for correct orifice size for a given heating value and specific gravity for natural and propane gas.

### Operation Above 2000' Altitude

**⚠ WARNING**

**Fire, Explosion, Poison carbon monoxide gas hazard.**

**This conversion shall be done by a qualified service agency in accordance with the Manufacturer's instructions and all applicable codes and requirements, or in the absence of local codes, the applicable national codes.**

**Failure to follow these instructions exactly can result in death, personal injury and/or property damage.**

These units may be used at full input rating when installed at altitudes up to 2000'. When installed above 2000', the high fire input must be decreased 2% (natural) or 4% (LP) for each 1000' above sea level. This may be accomplished by a simple adjustment of manifold pressure or an orifice change, or a combination of a pressure adjustment and an orifice change. The changes required depend on the installation altitude and the heating value of the fuel. **Table 3** & **Table 4** show the proper furnace manifold pressure and gas orifice size to achieve proper performance based on elevation above sea level for both natural gas and propane.

To use the natural gas table, first consult your local gas utility for the heating value of the gas supply. Select the heating value on the vertical border and follow across the table until the appropriate elevation for the installation is reached. The first value in the box at the intersection of the heating value and elevation will be the manifold pressure required. If a gas orifice change is also required, the box is shaded. The required orifice size is shown at the bottom of the table.

Sea Level  
High Altitude Input Rate = Nameplate x (Multiplier)  
Input Rate

Elevation	High Altitude Multiplier	
	Natural	LP Gas
2000' - 2999'	0.96	0.92
3000' - 3999'	0.94	0.88
4000' - 4999'	0.92	0.84
5000' - 5999'	0.90	0.80
6000' - 6999'	0.88	0.76
7000' - 7999'	0.86	0.72

# MANIFOLD PRESSURE AND ORIFICE SIZE FOR HIGH ALTITUDE APPLICATIONS

Table 3		NATURAL GAS													
HEATING VALUE BTU/CU. FT.		MEAN ELEVATION FEET ABOVE SEA LEVEL													
		0 to 1999 (" wc)		2000 to 2999 (" wc)		3000 to 3999 (" wc)		4000 to 4999 (" wc)		5000 to 5999 (" wc)		6000 to 6999 (" wc)		7000 to 8000 (" wc)	
		Hi	Lo	Hi	Lo	Hi	Lo	Hi	Lo	Hi	Lo	Hi	Lo	Hi	Lo
800		3.5	1.7	3.5	1.7	3.5	1.7	3.5	1.7	3.5	1.7	3.5	1.7	3.5	1.7
850		3.5	1.7	3.5	1.7	3.5	1.7	3.5	1.7	3.5	1.7	3.5	1.7	3.5	1.7
900		3.5	1.7	3.5	1.7	3.5	1.7	3.5	1.7	3.5	1.7	3.5	1.7	3.4	1.7
950		3.5	1.7	3.5	1.7	3.5	1.7	3.5	1.7	3.3	1.6	3.2	1.6	3.1	1.5
1000		3.5	1.7	3.4	1.7	3.3	1.6	3.2	1.5	3.0	1.5	2.9	1.4	2.8	1.4
1050		3.2	1.6	3.1	1.5	3.0	1.5	2.9	1.4	2.7	1.3	2.6	1.3	2.5	1.2
1100		2.9	1.4	2.8	1.4	2.7	1.3	2.6	1.3	2.5	1.2	2.4	1.2	2.3	1.1
Orifice Size		#42		#42		#42		#42		#42		#42		#42	

Table 4		LPG or PROPANE													
HEATING VALUE BTU/CU. FT.		MEAN ELEVATION FEET ABOVE SEA LEVEL													
		0 to 1999 (" wc)		2000 to 2999 (" wc)		3000 to 3999 (" wc)		4000 to 4999 (" wc)		5000 to 5999 (" wc)		6000 to 6999 (" wc)		7000 to 8000 (" wc)	
		Hi	Lo	Hi	Lo	Hi	Lo	Hi	Lo	Hi	Lo	Hi	Lo	Hi	Lo
2500		10.0	4.9	10.0	4.9	9.4	4.6	10.0	4.9	9.8	4.8	8.8	4.3	7.9	3.9
Orifice Size		#54		#54		#54		#55		#55		#55		#55	

NOTE: NATURAL GAS DATA BASED ON 0.60 SPECIFIC GRAVITY. PROPANE DATA BASED ON 1.53 SPECIFIC GRAVITY. FOR FUELS WITH DIFFERENT SPECIFIC GRAVITY CONSULT THE LATEST EDITION OF THE NATIONAL FUEL GAS CODE ANSI Z223.1 and CAN B149.

## Changing Orifices

1. After disconnecting power and gas supply to the furnace, remove the access door, exposing the burner compartment.
  - a. Remove the five (5) screws holding the burner box cover to expose the manifold and burners. (Figure 7 or Figure 8)
2. Disconnect gas line and pilot tubing from gas valve so manifold can be removed.
3. Disconnect wiring at gas valve. Be sure to note the proper location of any and all electrical wiring disconnected.
4. Remove the four (4) screws holding the manifold and gas valve to the manifold supports. Do not discard any screws. See (Figure 7 or Figure 8).

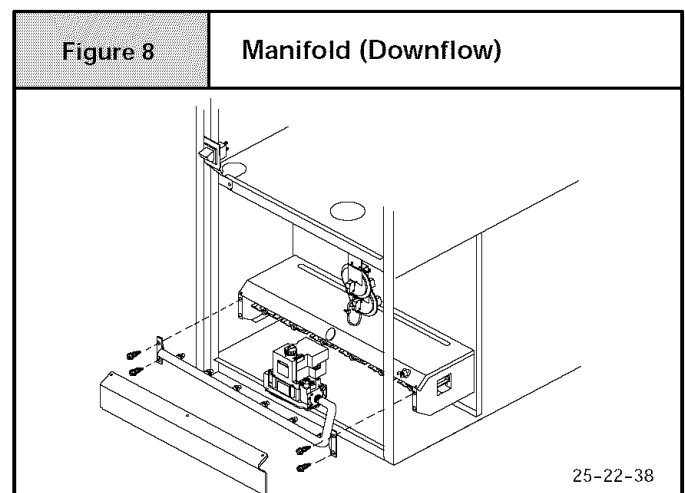
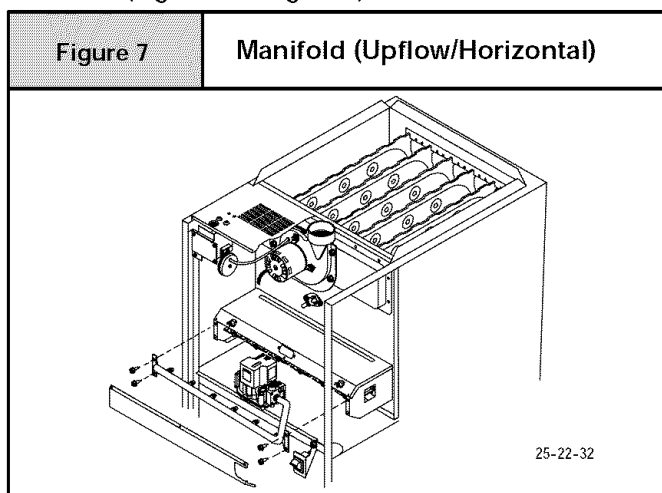

5. Carefully remove the manifold assembly.
6. Remove the orifices from the manifold and replace them with proper sized orifices. See Figure 9.
7. Tighten orifices so they are seated and gas tight. See Figure 9.

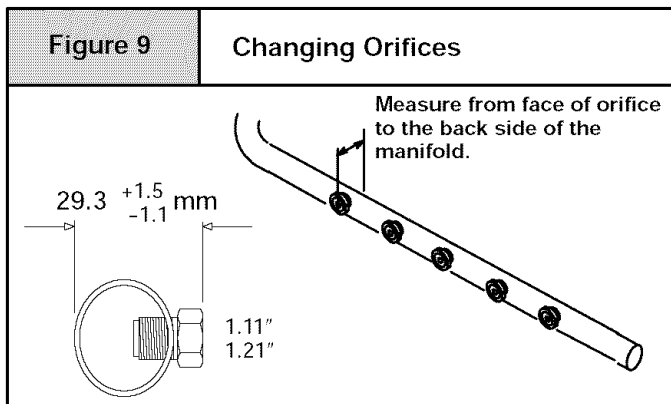

8. Reassemble all parts in reverse order as removed. Be sure to engage the main burner orifices in the proper opening in the burners.
9. After reassembling, turn gas on and check all joints for gas leaks using a soapy solution. All leaks must be repaired immediately.

## Gas Piping Requirements

1. Install gas piping in accordance with local codes, or in the absence of local codes, the applicable national codes.
2. It is recommended that a manual shutoff valve be installed in the gas supply line outside the unit. Locate valve as close to the furnace as possible where it is readily accessible. Refer to Figure 10.

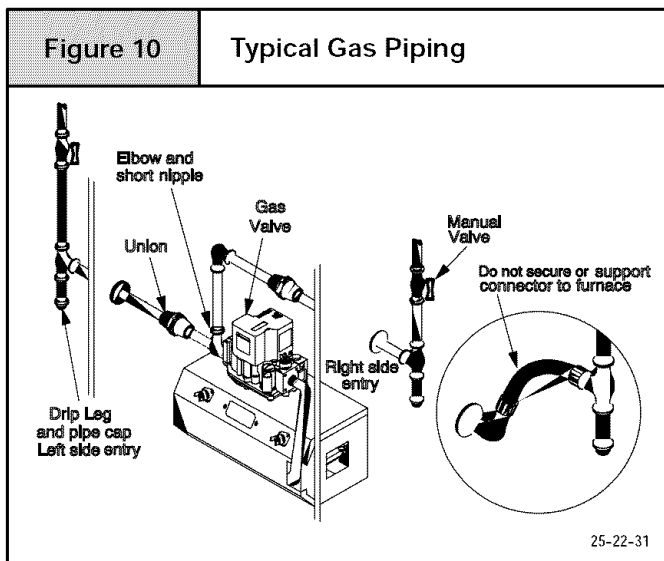

3. Use black iron or steel pipe and fittings or other pipe approved by local code.
4. Use pipe thread compound which is resistant to natural and LP gases.
5. Install a drip leg no less than 3" long to trap dirt and moisture before it can enter gas valve.
6. Provide a  $\frac{1}{8}$ " inch plug for test gauge connection immediately up stream of gas supply connection to furnace.
7. Use two pipe wrenches when making connections to prevent gas valve from turning.

8. Flexible corrugated metal gas connector may **NOT** be used inside the furnace or be secured or supported by the furnace or ductwork.
9. Properly size gas pipe to handle combined appliance load or run gas pipe directly from gas meter or LP gas regulator.
10. Install correct pipe size for run length and furnace rating.
11. Measure pipe length from gas meter or LP second stage regulator.

## **⚠ WARNING**

Fire or explosion hazard.

Gas connector must be properly installed, cannot go through the side of the furnace, and can not be used inside the furnace.

Failure to properly install gas connector can result in death, bodily injury and/or property damage.

## Additional LP Piping Requirements

- Have a licensed LP gas dealer make all connections at storage tank and check all connections from tank to furnace.
- If copper tubing is used, it **MUST** comply with limitation set in Local Codes, or in the absence of local codes, the gas codes of the country having jurisdiction. See Appendix.
- Two-stage regulation of LP gas is recommended.

## **⚠ WARNING**

Fire or explosion hazard.

Liquid petroleum (LP) gas is heavier than air and will settle and remain in low areas and open depressions.

Thoroughly ventilate area and dissipate gas. Do **NOT** use a match or open flame to test for leaks, or attempt to start up furnace before thoroughly ventilating area.

An open flame or spark can result in death, personal injury and/or property damage.

## Final Check

- Test all pipe for leaks.
- If orifices were changed, make sure they are checked for leaks.
- During pressure testing of gas piping system, observe the following:
  - a. If test pressure does not exceed  $\frac{1}{2}$ " PSIG, isolate the furnace by closing its individual manual shutoff valve.
  - b. If test pressure exceeds  $\frac{1}{2}$ " PSIG, the furnace and its individual shutoff valve must be disconnected from the gas supply system.
- To check for leaks apply soap suds or a liquid detergent to each joint. Bubbles forming indicate a leak.
- Do not use an open flame to test for gas leaks. Fire or explosion could occur.
- Correct even the smallest leak at once.

## 7. Electrical Wiring

### **⚠ WARNING**

Electrical shock hazard.

Turn OFF electrical power at fuse box or service panel before making any electrical connections and ensure a proper ground connection is made before connecting line voltage.

Failure to do so can result in death, personal injury and/or property damage.

### Power Supply Wiring

The furnace **MUST** be electrically wired and grounded in accordance with local codes, or in the absence of local codes, the applicable national codes.

Field wiring connections must be made inside the furnace connection box. A suitable strain relief should be used at the point the wires exit the furnace casing.

Copper conductors shall be used. Line voltage wires should be sized for the input amps stated on the rating plate. Furnace must be connected to its own separate circuit.

### Thermostat

The 2-stage furnace control will operate with either a single stage or a two stage heating thermostat and will provide 2-stage heating operation. For single stage thermostat installations, the R and W wires from the thermostat connect to the R and W1 connections on the furnace control. **Note:** The fourth (4th) DIP switch should be in the off position for the furnace to operate properly with a single stage thermostat. Failure to change DIP switch with single stage thermostat will result in Low Fire operation ONLY. (See wiring diagram) During operation, the furnace will operate on low fire for 12 minutes. If the heat request exists for more than 12 minutes, the furnace will automatically shift to the high fire mode for the remaining duration of the heating cycle. For 2-stage thermostat installations, the R, W1 and W2 wires from the thermostat connect to the R, W1 and W2 connections on the furnace control. During operation, the furnace will shift from low fire to high fire as requested by the thermostat. The thermostat heat anticipator should be adjusted to a .10 setting for both types of thermostats.

Thermostat location has an important effect on the operation of the unit. Follow instructions included with thermostat for correct mounting and wiring.

Low voltage connections to furnace must be made on terminal board to fan control.

### Optional Equipment

All wiring from furnace to optional equipment **MUST** conform to local codes or, in the absence of local codes, the applicable national codes. Install wiring in accordance with manufacturer's instructions.

### Humidifier/Electronic Air Cleaner

The furnace is wired for 115 VAC humidifier and/or electronic air cleaner connection.

#### CAUTION

Do **NOT** exceed 115V/0.8 amp. maximum current load for both the EAC terminal and the HUM terminal combined.

**NOTE:** The humidifier will be powered when the furnace is fired and the circulating air blower comes on. The electronic air cleaner will be powered anytime the thermostat calls for air movement. However, the electronic air cleaner is **NOT** energized during continuous fan operation controlled by the electronic fan control.

### Dehumidification (NTV6/VNE)

The fan control is wired for 24 VAC normally open (N/O) dehumidistat connection. Connect dehumidistat to the R terminal and the 1/4" male quick connect Y2 terminal on the fan control (See **Figure 14** and "Furnace Wiring Diagram") A 20% reduction of cooling airflow will occur when the Y2 dehumidistat terminal is energized during a call for cooling from the thermostat.

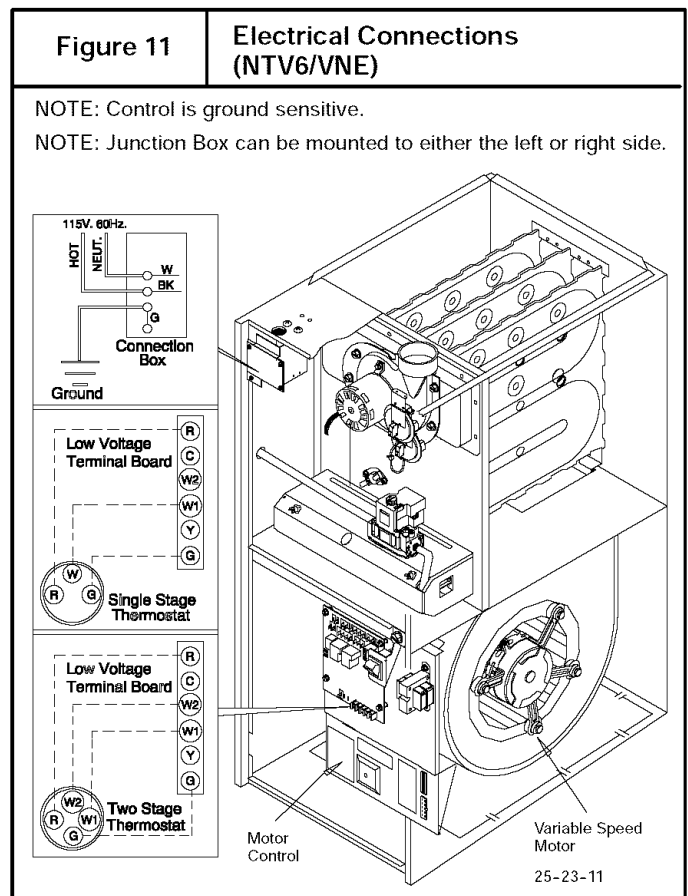
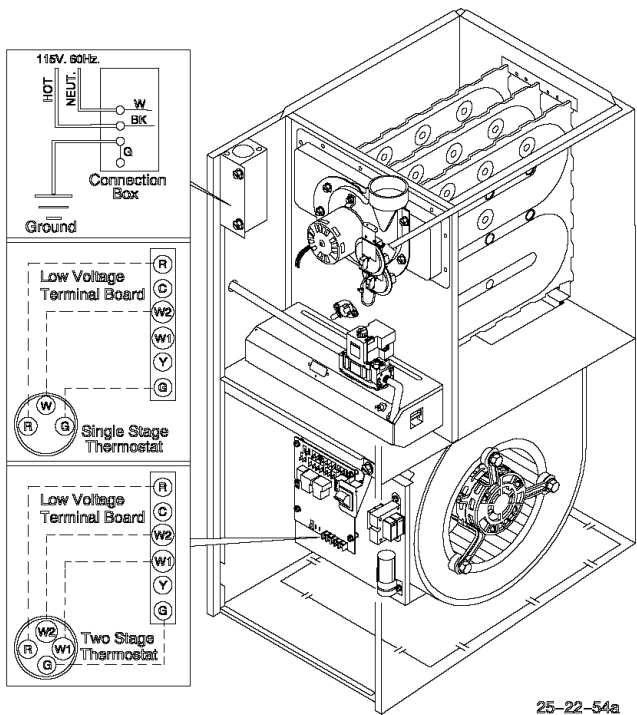

Figure 12

Electrical Connections NTP6/TNE (Upflow/Horizontal)

NOTE: Control is ground sensitive.

NOTE: Junction Box can be mounted to either the left or right side.



25-22-54a

Figure 13

Electrical Connections NDP6/TDE (Downflow)

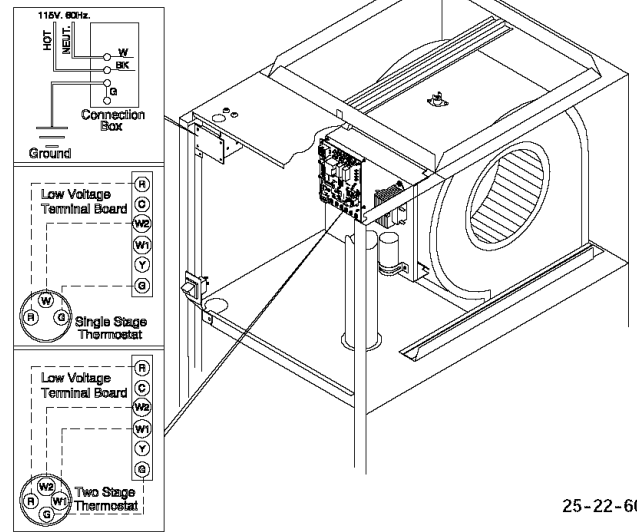

25-22-60

Fan Control

The fan control is preset at the factory with an adjustable blower ON delay of 30 seconds in the heating mode. The blower OFF timing is preset at 140 seconds. If desired, the fan ON delay and OFF delay can be reset to obtain the longest delay times while still maintaining comfort levels. See "Furnace Wiring Diagram".

NOTE: It is recommended to achieve maximum efficiency that the fan control be set to turn on at 30 seconds after the burners light.

NOTE: For single stage thermostat operation the fourth (4th) DIP switch must be in the off position. (See furnace wiring diagram and Figure 14). Failure to change switch with single stage thermostat will result in Lo fire operation ONLY.

Figure 14

Fan Timer Connections

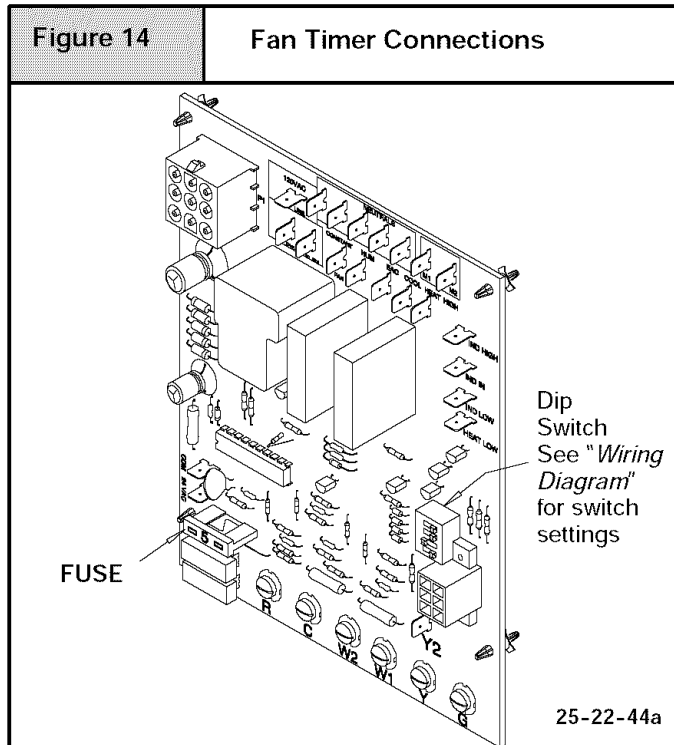

Dip Switch See "Wiring Diagram" for switch settings

25-22-44a

## 8. Ductwork and Filter (NTV6/VNE & NTP6/TNE)

### **⚠ WARNING**

Poison carbon monoxide gas hazard.

Do **NOT** draw return air from inside a closet or utility room where furnace is located. Return air duct **MUST** be sealed to furnace casing.

Failure to properly seal duct can result in death and/or personal injury.

### Duct Connections

This furnace may be installed in only a bottom or side return application. Return air through the back of the unit is **NOT** allowed.

Side connections can be made by cutting out the embossed area shown in Figure 15.

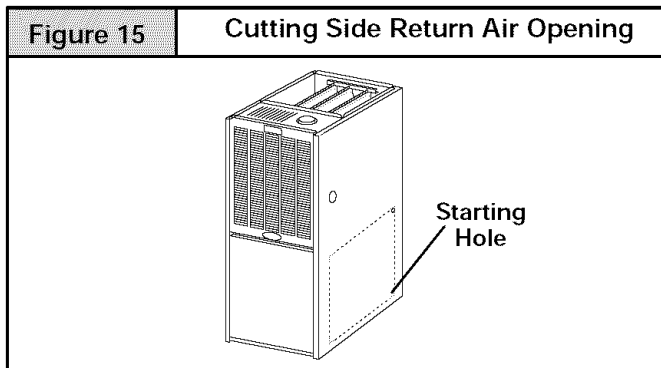

Bottom returns can be made by removing the knockout panel in the furnace base. Do **NOT** remove knock-out except for a bottom return.

### Duct Design (NTV6/VNE & NTP6/TTNE)

Design and install air distribution system to comply with Air Conditioning Contractors of America manuals or other approved methods that conform to local codes and good trade practices.

When the furnace is located in an area near or adjacent to the living area, the system should be carefully designed with returns to minimize noise transmission through the return air grille. Any blower moving a high volume of air will produce audible noise which could be objectionable when the unit is located very close to a living area. It is often advisable to route the return air ducts under the floor or through the attic.

- Refer to furnace **Technical Support Manual** (Blower Data) for air flow information.
- Size ductwork to handle air flow for heating and air conditioning.

### Duct Installation Requirements

- When furnace supply ducts carry air outside furnace area, seal return air duct to furnace casing and terminate duct outside furnace space.

- When a refrigeration coil is used in conjunction with this unit, it must be installed on the discharge side of the unit to avoid condensation on the heat exchanger.
- If separate evaporator and blower unit is used, install good sealing dampers for air flow control. Chilled air going through the furnace could cause condensation and shorten furnace life. Dampers (purchased locally) can be either automatic or manual. Manually operated dampers **MUST** be equipped with a means to prevent furnace or air conditioning operation unless damper is in the full heat or cool position.

### **⚠ WARNING**

Poison carbon monoxide gas hazard.

Cool air passing over heat exchanger can cause condensate to form resulting in heat exchanger failure.

This could result in death and/or personal injury.

- Installation of locking-type dampers are recommended in all branches, or in individual ducts to balance system's air flow.
- Non-combustible, flexible duct connectors are recommended for return and supply connections to furnace.
- If air return grille is located close to the fan inlet, install at least one, 90° air turn between fan and inlet grille to reduce noise.
- Ductwork installed in attic, or exposed to outside temperatures require 2" of insulation with outdoor type vapor barrier.
- Ductwork installed in an indoor unconditioned space requires a minimum of 1" of insulation with indoor type vapor barrier.

### Inspection Panel on some models

A removal access panel should be provided in the outlet duct when the furnace is installed without a cooling coil. This will allow smoke or reflected light to be observable inside the casing to indicate the presence of leaks in the heat exchanger. This access cover shall be attached in such a manner as to prevent air leaks.

### Filters

A filter **MUST** be used. Filters may not be supplied with all models, but can be purchased from your dealer.

The furnaces, with 1600 or less CFM rating, are supplied with a 16" x 25" high velocity filter and rack. On these models, the supplied filter rack may be mounted internally for bottom return or externally for side return.

The furnaces with greater than 1600 CFM requires that both left and right side returns are used in side return applications. Two 16" x 25" high velocity filters and racks are provided with furnace. Filter racks must be mounted externally. If return air must be on one side only, an optional 20" x 25" filter standoff rack kits can be used. (See **Figure 16**) For bottom return, an optional 20" x 25" filter rack kit can be mounted internally.



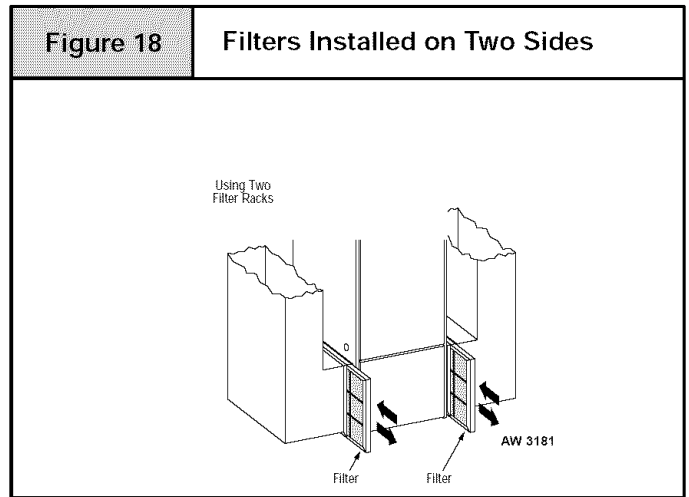
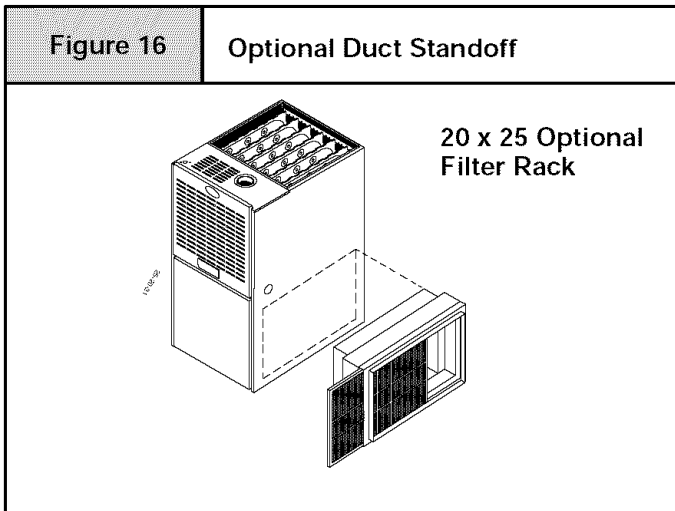

## Filters Rack Installation

### Side Return

Center the filter rack on the side panel, flush with the bottom edge of the furnace. Mark the fastening holes. Drill the fastening holes in the side panel and fasten the filter rack in place with sheet metal screws. See **Figure 17** & **Figure 18**.

### CAUTION

If filters are only suitable for heating application, advise homeowner that filter size may need to be increased if air conditioning is added.

### Bottom Return

When installing a bottom mounted filter rack, slide the two side filter clips to the back of the furnace **BEFORE** installing. This will allow the rack to clear the front raised edge of the furnace. Insert rack into side clips first and push rack back until it is fully engaged into back clip. When rack is in place, slide clips back into place midway on rack as shown in **Figure 19**.

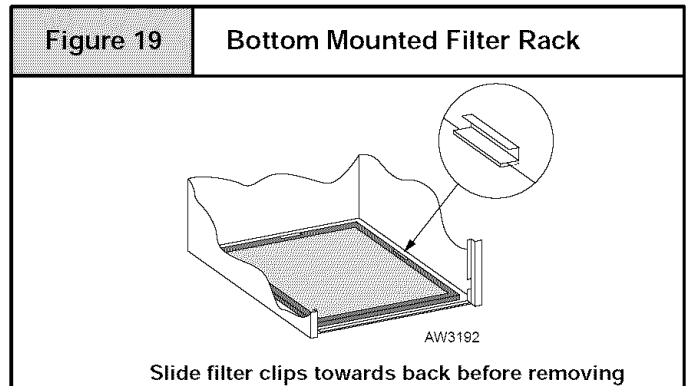
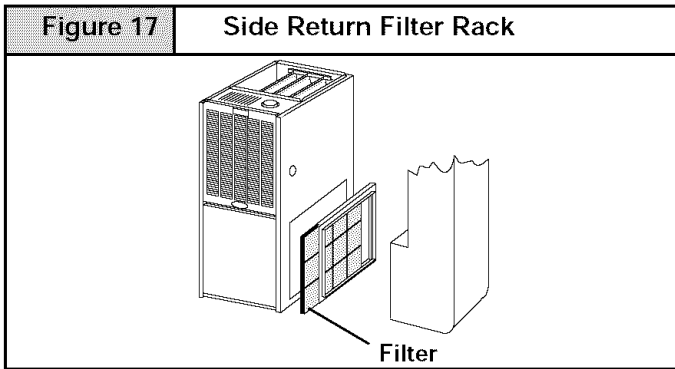

## 9. Ductwork and Filter (Downflow/Horizontal) on NDP6/TDE

### Sub-Bases for Combustible Floors - Furnace Only

The Subbase for Combustible Floors **MUST** be used when a downflow furnace is set on combustible material even when the furnace is installed on a coil box (cased coil).

**NOTE:** Supply opening is  $3\frac{7}{8}$ " from the rear of the furnace. Therefore maintain a  $3\frac{7}{8}$ " clearance from a wall behind the furnace (where applicable).

1. Cut the opening in the floor according to **Table 5**. The hole in the floor must be cut to the dimensions listed in **Table 5** since the base is equipped with locating tabs that center the base over the opening.

The opening in the base is  $1\frac{1}{4}$ " (32mm) shorter and  $1\frac{1}{8}$ " (29mm) narrower than the minimum required size of the opening in the floor. This is done to maintain a 1" clearance between the floor and the plenum.

2. Fabricate the plenum to the dimensions given in **Table 5**. Note that the dimensions given are outside dimensions.

Table 5 Sub-bases for Combustible Floors Dimensions										
sub-base for Combustible Floors Part Number	sub-base for Combustible Floor Dimensions				Opening In Floor		Opening In Base For Plenum		Typical Plenum Dimensions	
	H*	J*	K**	L	M	N	P	R	S	T
<b>(Furnace Only)</b>										
NAHH001SB	15 <sup>11</sup> / <sub>16</sub>	28 <sup>3</sup> / <sub>4</sub>	14 <sup>9</sup> / <sub>16</sub>	16	16 <sup>1</sup> / <sub>4</sub>	14 <sup>5</sup> / <sub>8</sub>	15	13 <sup>1</sup> / <sub>2</sub>	15	13 <sup>1</sup> / <sub>2</sub>
NAHH002SB	19 <sup>5</sup> / <sub>16</sub>	28 <sup>3</sup> / <sub>4</sub>	18 <sup>3</sup> / <sub>16</sub>	16	16 <sup>1</sup> / <sub>4</sub>	18 <sup>1</sup> / <sub>4</sub>	15	17 <sup>1</sup> / <sub>8</sub>	15	17 <sup>1</sup> / <sub>8</sub>
NAHH003SB	22 <sup>15</sup> / <sub>16</sub>	28 <sup>3</sup> / <sub>4</sub>	21 <sup>13</sup> / <sub>16</sub>	16	16 <sup>1</sup> / <sub>4</sub>	21 <sup>7</sup> / <sub>8</sub>	15	19 <sup>3</sup> / <sub>4</sub>	15	19 <sup>3</sup> / <sub>4</sub>
<b>sub-base for Cased Coil</b>										
NAHH004SB	15 <sup>11</sup> / <sub>16</sub>	20 <sup>9</sup> / <sub>16</sub>	14 <sup>9</sup> / <sub>16</sub>	16	16 <sup>1</sup> / <sub>4</sub>	14 <sup>5</sup> / <sub>8</sub>	15	13 <sup>1</sup> / <sub>2</sub>	15	13 <sup>1</sup> / <sub>2</sub>
NAHH005SB	19 <sup>5</sup> / <sub>16</sub>	20 <sup>9</sup> / <sub>16</sub>	18 <sup>3</sup> / <sub>16</sub>	16	16 <sup>1</sup> / <sub>4</sub>	18 <sup>1</sup> / <sub>4</sub>	15	17 <sup>1</sup> / <sub>8</sub>	15	17 <sup>1</sup> / <sub>8</sub>
NAHH006SB	22 <sup>15</sup> / <sub>16</sub>	20 <sup>9</sup> / <sub>16</sub>	21 <sup>13</sup> / <sub>16</sub>	16	16 <sup>1</sup> / <sub>4</sub>	21 <sup>7</sup> / <sub>8</sub>	15	19 <sup>3</sup> / <sub>4</sub>	15	19 <sup>3</sup> / <sub>4</sub>

\* Outside Dimension  
\*\* Base Spacer Side To Side

3. Set the base over the opening in the floor, centering the opening in the base over the opening in the floor. Fasten the base to the floor with screws or nails. See **Figure 20** and **Figure 22**.

3. Set the base over the opening in the floor, centering the opening in the base over the opening in the floor. Fasten the base to the floor with screws or nails. See **Figure 21** and **Figure 22**.

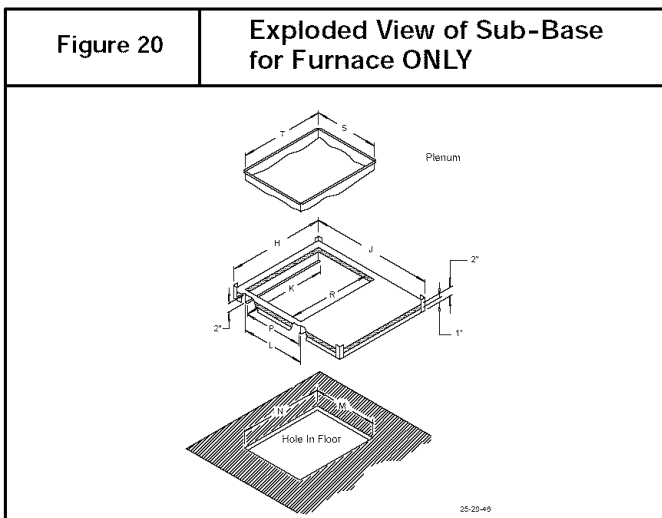

4. Drop the plenum through the opening in the base. The flange of the plenum should rest on top of the combustible floor base.

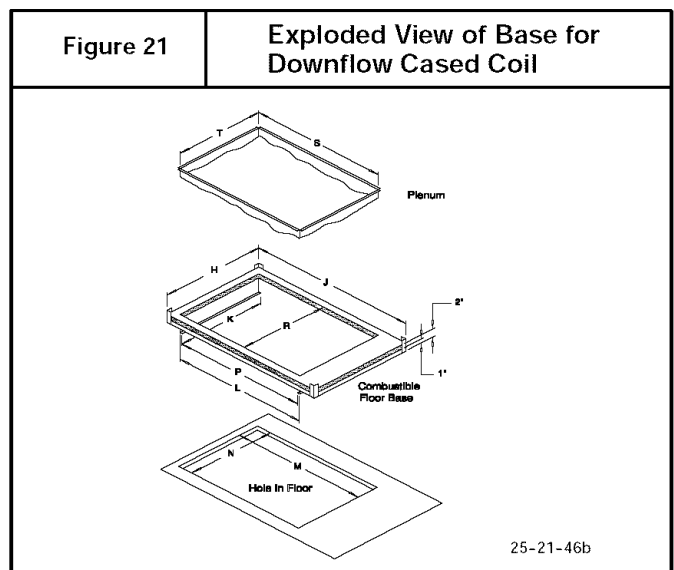

4. Drop the plenum through the opening in the base. The flange of the plenum should rest on top of the combustible floor base.

### Sub-base for Combustible Floors- Downflow Coil Box

The Subbase for Combustible Floors **MUST** be used when a downflow furnace, *used with a downflow coil box*, is set on combustible flooring.

**NOTE:** Supply opening is 3<sup>7</sup>/<sub>8</sub>" from the rear of the furnace. Therefore maintain a 3<sup>7</sup>/<sub>8</sub>" clearance from wall (where applicable).

1. Cut the opening in the floor according to **Table 6**. The hole in the floor must be cut to the dimensions listed in **Table 6** since the base is equipped with locating tabs that center the base over the opening.

The opening in the base is 1<sup>1</sup>/<sub>4</sub>" (32mm) shorter and 1<sup>1</sup>/<sub>8</sub>" (29mm) narrower than the recommended size of the opening in the floor. This is done to provide a 1" clearance between the floor and the plenum.

2. Fabricate the plenum to the dimensions given in **Table 6**. Note that the dimensions given are outside dimensions.

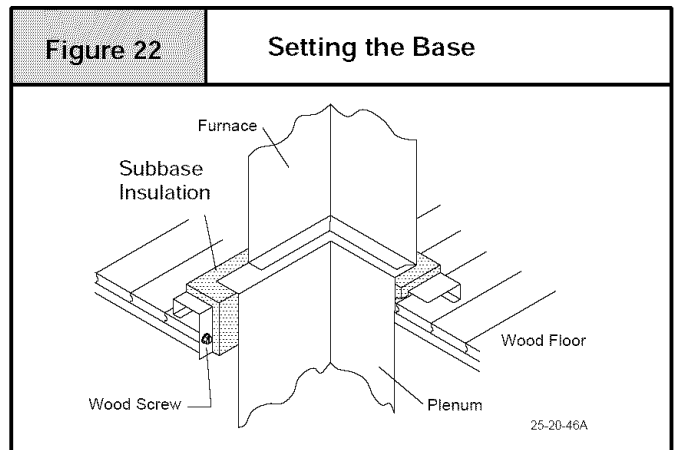

This subbase for combustible floors has been designed so that the height of the sub-base raises the downflow coil off the floor to allow easy installation of the condensate drain. See **Figure 23**.

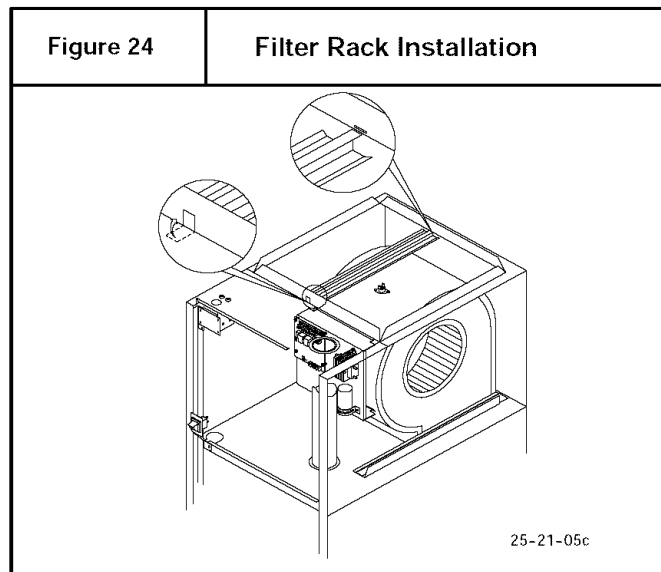
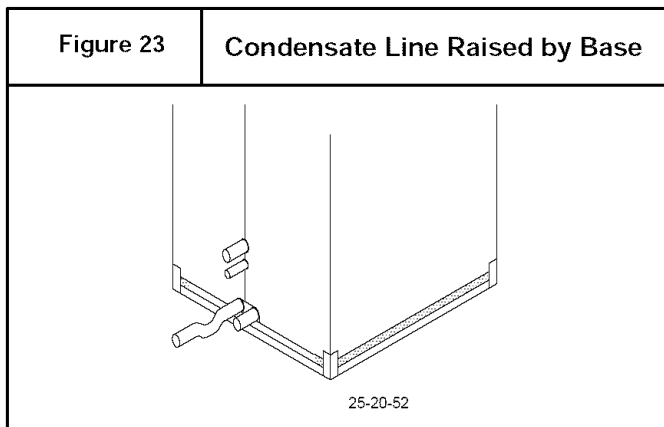

### Non-Combustible Floor:

Set the furnace over the opening in the floor. If necessary, grout around the base to seal air leaks between the base and the floor.

### Filters:

The filters supplied with the furnace may be installed in the return air plenum above the furnace. A filter rack is supplied with each furnace. See **Figure 24**.

**NOTE:** The return air plenum **MUST** extend a sufficient height above dimension "A" (**Figure 25**) to provide for the attachment of a return air duct or grille above the filters.

**NOTE:** The furnace is provided with high velocity type filter(s). The size, quantity, and type of filter supplied with the furnace will handle the airflow required if central air conditioning is used with the furnace.

1. Insert end of filter rack with  $\frac{3}{4}$ " (19mm) flange into slot in the back of the unit. See **Figure 24**.
2. With filter rack pushed back, insert front end with  $\frac{1}{4}$ " (6mm) flange into position and push into front slot. With filter rack pushed as far forward as it will go, bend  $\frac{1}{4}$ " (6mm) flange and  $\frac{3}{4}$ " (19mm) flange up 90 degrees. See **Figure 24**.

**NOTE:** Plenum must be fitted as close to the return air flange of the unit as possible to eliminate any air bypassing the filters.

3. Filters can only be installed through the right hand side of the unit blower opening. Slide filter into unit until it is in position to be pushed up and over into place on the left hand side of unit. See **Figure 25**.
4. Slide remaining filter into unit and up into place on left hand side of unit. See **Figure 25**.

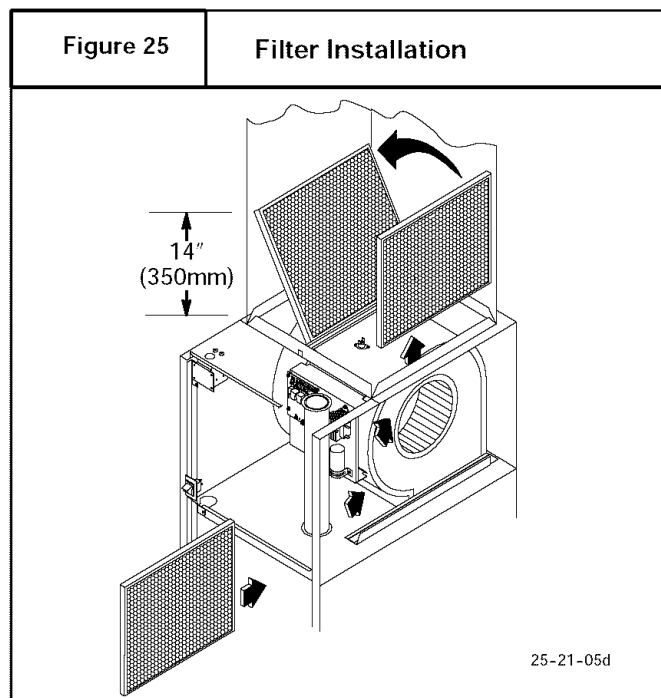

## 10. Checks and Adjustments

### Startup

**NOTE:** Refer to startup procedures in the *Users Information Manual*.

### CAUTION

If any sparks, odors or unusual noises occur, immediately shut OFF power to furnace. Check for wiring errors or obstruction to blower.

## Gas Supply Pressure

Gas supply pressure should be within minimum and maximum values listed on rating plate. Pressures are usually set by gas suppliers.

(See L.P. Kit instruction manual for furnaces converted to L.P. gas)

## Adjust Pilot Burner

The furnace has a pilot flame to light the main burner. The flame should surround  $\frac{3}{8}$ " to  $\frac{1}{2}$ " of the flame rod. See **Figure 26**. To adjust, remove cap from pilot adjusting screw on gas valve. Turn screw counterclockwise to increase or clockwise to decrease flame as required. Replace cap after adjusting screw.

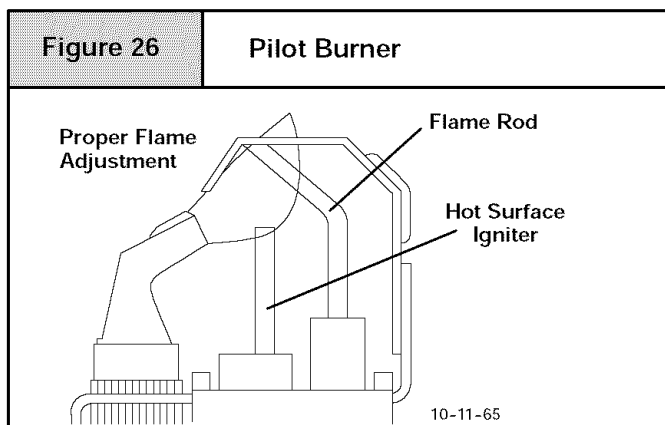

## Main Burner Flame Check

Allow the furnace to run approximately 10 minutes then inspect the main burner and pilot flames. See **Figure 27**.

Check for the following (**Figure 27**):

- Stable and blue flames. Dust may cause orange tips or wisps of yellow, but flames **MUST NOT** have solid, yellow tips.
- Flames extending directly from burner into heat exchanger.
- Flames do **NOT** touch sides of heat exchanger

If any problems with main burner flames are noted, it may be necessary to adjust gas pressures, or check for drafts.

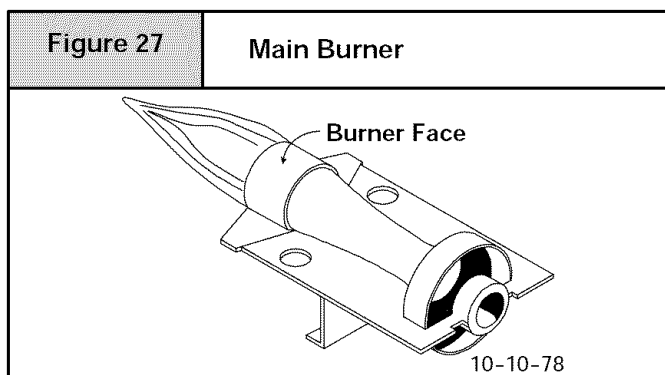

## Temperature Rise Check

The blower speed **MUST** be set to give the correct air temperature rise through the furnace as marked on the rating plate. Temperature rise is the difference between supply and return air temperatures.

To check temperature rise, use the following procedure:

1. Place thermometers in supply and return air registers as close to furnace as possible, avoiding direct radiant heat from heat exchangers.
2. Operate furnace on high fire for 10 minutes with all the registers and duct dampers open by using a jumper wire on R to W1 and W2 thermostat connections on the fan board. **Note:** The fourth (4th) DIP Switch should be in the on position. (See furnace wiring diagram)
3. Take readings and compare with range specified on rating plate.
4. If the temperature rise is not in the correct range, the blower speed must be changed. A higher blower speed will lower the temperature rise. A lower blower speed will increase the temperature rise.
5. Repeat steps 2 thru 4 with the furnace operating on low fire for 10 minutes by using a jumper wire on the R to W1 thermostat connections on the fan board.
6. Remove the jumper wire after the adjustments are complete. Return fourth (4th) to previous setting.

## Changing Blower Speed on NTP6/TNE & NDP6/TDE

### ⚠ WARNING

Electrical shock hazard.  
Turn OFF power to furnace before changing speed taps.  
Failure to do so can result in death and/or personal injury.

Since the manufacturer cannot establish the static pressure that will be applied to the unit, it is the responsibility of the installer dealer/contractor to select the proper blower speeds for the application when the unit is installed.

If it is necessary to change speeds, refer to steps below.

1. Refer to *Furnace Wiring Diagram* for location of the heating and cooling speed taps located on the electronic fan control as well as location of unused blower motor speed leads. Use the chart (**Table 6**) to determine the blower motor speed settings.

Table 6		Blower Speed Chart	
Wire Color		Motor Speed	
Black		High	
Orange*		Med-High	
Blue		Medium	
Red		Low	
* Med-High speed may not be provided on all models.			

2. Change the heat or cool blower motor speed by removing the motor lead from the "Heat" or "Cool" terminal and replace it with the desired motor speed lead from the "Unused Motor Lead" location. Connect the wire previously removed from the "Heat" or "Cool" terminal to the vacated "Unused Motor Lead" terminal.
3. If the same speed must be used for both heating and cooling, remove the undesired motor speed lead from the "Heat" or "Cool" terminal and connect that lead to the open terminal at "Unused Motor Lead" location or tape off. Attach a jumper between the "Heat" and "Cool" terminals and the remaining motor speed lead.

**Note:** When using the same speed on motors with (4) speed leads, it will be necessary to tape off the terminal of the motor speed lead removed from the "Heat" or "Cool" terminal with electrical tape since an open terminal will not be available at the "Unused Motor Lead" location.

nal, this will provide low speed blower operation whenever the other two speeds (Heat or Cool) are not energized.

## Continuous Fan Operation

A terminal is provided on the electronic fan control located in the circulating blower compartment for operation of the continuous fan option. This connection is intended for the low speed motor tap, and has a lower contact rating (8 amps) than the heat and cool taps. When the low speed blower lead is connected to this termi-

## Heating and Continuous Blower Speed the Same

If it is necessary to operate the heating speed and continuous blower speed using the same blower speed, connect a jumper between the "Heat" and "Cont" terminals on the electronic fan control.

**Note:** There should be only ONE motor lead going to the "Heat" and "Cont" terminals.

**Note:** The blower speeds that the manufacturer sets from the factory for this product are based on a nominal 400 CFM per ton cooling and the mid range on the temperature rise for heating.

## Changing Blower Speed on NTV6/VNE

**⚠ WARNING**

Electrical shock hazard.  
Turn OFF power to furnace before changing speed taps.  
Failure to do so can result in death and/or personal injury.

Since the manufacturer cannot establish the static pressure that will be applied to the unit, it is the responsibility of the installer dealer/contractor to select the proper blower speeds for the application when the unit is installed.

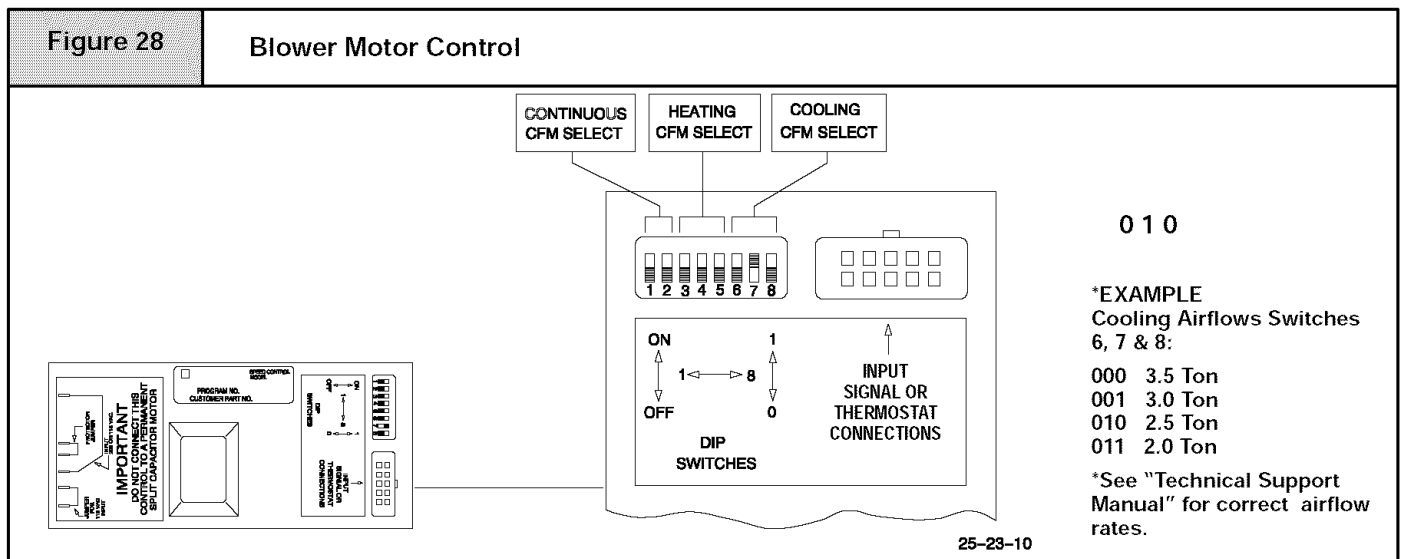

If it is necessary to change speeds, refer to steps below.

1. The 115 VAC power supply to the furnace must be turned OFF before making adjustments to the motor.

2. The heating, cooling and continuous blower speeds can be adjusted by changing the switch settings that are located on the motor control (see Figure 28). Switches #1 and #2 adjust the continuous blower speeds. Switches #3, #4 and #5 adjust the heating speeds. Switches #6, #7 and #8 adjust the cooling speed. See the "Technical Support Manual" for the switch settings for the desired airflow rates for the installation.

## 11. Furnace Maintenance

### CAUTION

See "User's Information Manual".

It is recommended that the furnace be inspected and serviced on an annual basis (before the heating season) by a qualified service technician.

## 12. Sequence of Operation & Diagnostics for NTV6/VNE

The following is the normal operating sequence for the 2-stage control system.

### Cooling (Y) Request:

- 24 VAC signals applied to Y & G terminals of EFT (electronic fan timer) control.
  - Cool motor speed energized after 5 second Cool Fan On Delay time.

Y & G signals removed from EFT.

- Cool motor speed de-energized after 60 second Cool Fan Off Delay time.

Cooling (Y) and dehumidification (Y2) requests: (Variable Speed ONLY)

- 24 VAC signals applied to Y, Y2 & G terminals of EFT (electronic fan timer) control.
- Same operation as the cooling (Y) request, except the cooling speed is reduced 20% to compensate for high humidity conditions during cooling operation. The cooling speed returns to the normal setting after the Y2 signal is removed.

### **Circulating Fan (G) Request:**

24 VAC signals applied to G terminals of EFT control.

- Low motor speed energized without delay.

G signal removed from EFT.

- Low motor speed de-energized without delay.

NOTE1) Furnaces with DC blower motors run a low circulating fan speed in response to G request.

NOTE2) Furnaces with PSC blower motors de-energize the Low Heat fan speed during the heat exchanger warm-up period on a call for Heating that occurs during a G request.

NOTE3) Heating or Cooling requests received during a Fan request cause the fan speed to change to the appropriate heat or cool speed after the selected Fan On Delay time expires. The fan returns to circulating speed after the selected Fan Off Delay time expires following loss of the Heating or Cooling request.

### **Heating (W1) Request (single stage thermostat operation, 4th DIP switch on fan timer, must be in off position) (see furnace wiring diagram):**

24 VAC signals applied to W1 terminal of EFT control.

- Inducer motor turns on at high speed.
- The high fire solenoid energizes.
- Following a 3 second prepurge delay, the pilot valve opens and the ignitor begins to warm up.
- After the pilot lights, the main burners energize and light (burners now at high fire rate).
- Timed from the opening of the main gas valve, the control will delay the selected Heat Fan On Delay time before switching the inducer to low speed, de-energizing the high fire solenoid and the fan switches to Low Heat speed.
- Timed from initial application of the Heating request, if the W1 request is still present after the Low Fire Delay time expires (12 minutes), the inducer switches to high speed, the high fire solenoid energizes and the fan switches to High Heat speed.

W1 signal removed from EFT.

- The gas valve de-energizes and the main burners go out.
- The inducer runs at its present speed for a 5 second postpurge period.
- The fan switches to (or stays at) Low Heat speed.
- Timed from the gas valve de-energizing, the Low Heat fan speed de-energizes after the selected Heat Fan Delay time expires.

NOTE4) If a new Heating request arrives while the control is waiting in the Heat Fan Off Delay time, the fan speed switches to High Heat until the Heat Fan Off Delay expires or the Heat Fan On Delay expires for the new Heating request.

### **Heating Request (two stage thermostat operation, 4th DIP switch must be in on position) (see furnace wiring diagram):**

24 VAC signals applied to W1 terminal of EFT control.

- Same response as single stage thermostat operation described above except the control will not go to high fire, High Heat fan speed unless a W2 signal is applied.

24 VAC signals applied to W1 and W2 terminals of EFT control.

- Same light-off routine as described for the signal stage thermostat operation except that at the end of the selected Heat Fan On Delay, the inducer remains on high fire, the high fire solenoid remains energized and the High Heat fan speed energizes.

NOTE5) The EFT control responds without delay to the presence or loss of W2 (with W1 constant). W1 & W2 results in high inducer, high fire and High Heat fan speed. W1 only results in low inducer, low fire and Low Heat fan speed.

### **Heating Request with Gas Supply Line Shut Off:**

24 VAC signals applied to W1 terminal of EFT control.

- Inducer motor turns on at high speed.
- The high fire solenoid energizes.
- Following a 3 second prepurge delay, the pilot valve opens and the igniter begins to warm up.
- The igniter glows red-hot for 30 seconds, then turns off.

- The igniter stays off for 25 seconds, then begins to warm-up again.
- The igniter glows red-hot for 30 seconds, then turns off.
- The pilot valve closes 3 seconds after the igniter de-energizes.
- The inducer de-energizes 5 seconds after the pilot valve closes.
- The SmartValve proceeds to soft lockout and flashes error code 6.
- The control exits soft lockout after 5 minutes and begins another ignition sequence.

## Gas Valve Diagnostic Codes (See Figure 29)

- Steady Flash = Normal Operation
- 2 Flashes = Low Pressure Switch Stuck Closed
- 3 Flashes = Low Pressure Switch Stuck Open or Manual ON/OFF Switch in OFF Position or (Aux. Limit Switch Open - Upflow ONLY)
- 4 Flashes = Limit Switch Open (Aux. Limit Switch Open - Downflow ONLY)
- 5 Flashes = Flame Sensed Out of Sequence
- 6 Flashes = Control in Soft Lockout (Automatic Restart or Retry Delay)
- 8 Flashes = High Pressure Switch Stuck Closed
- 9 Flashes = High Pressure Switch Stuck Open

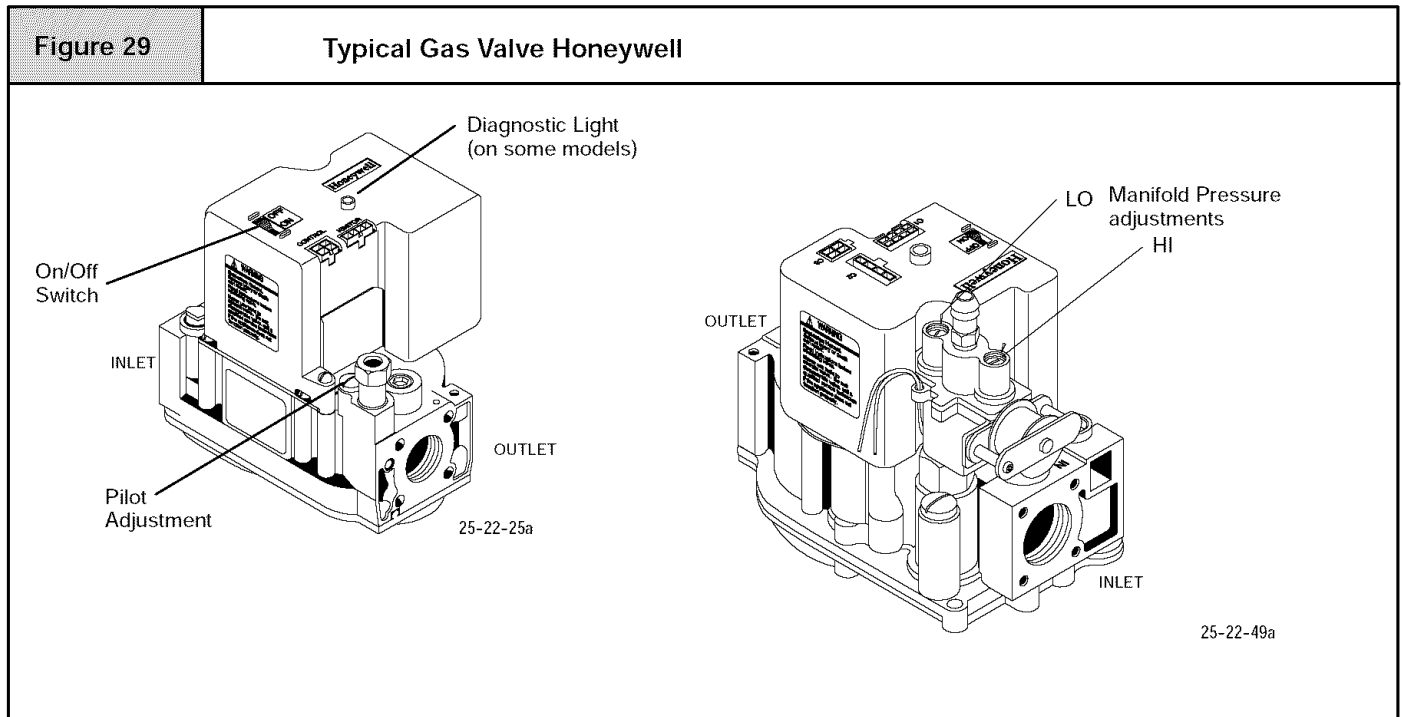

## 11. Sequence of Operation & Diagnostics for NTP6/TNE & TDP6/TDE

The following is the normal operating sequence for the 2-stage control system.

### Cooling (Y) Request:

- 24 VAC signals applied to Y & G terminals of EFT (electronic fan timer) control.
- Cool motor speed energized after 5 second Cool Fan On Delay time.

Y & G signals removed from EFT.

- Cool motor speed de-energized after 60 second Cool Fan Off Delay time.

Cooling (Y) and dehumidification (Y2) requests: (Variable Speed ONLY)

- 24 VAC signals applied to Y, Y2 & G terminals of EFT (electronic fan timer) control.
- Same operation as the cooling (Y) request, except the cooling speed is reduced 20% to compensate for high humidity conditions during cooling operation. The cooling speed returns to the normal setting after the Y2 signal is removed.

## **Circulating Fan (G) Request:**

24 VAC signals applied to G terminals of EFT control.

- Low motor speed energized without delay.

G signal removed from EFT.

- Low motor speed de-energized without delay.

NOTE1) Furnaces with DC blower motors run a low circulating fan speed in response to G request.

NOTE2) Furnaces with PSC blower motors de-energize the Low Heat fan speed during the heat exchanger warm-up period on a call for Heating that occurs during a G request.

NOTE3) Heating or Cooling requests received during a Fan request cause the fan speed to change to the appropriate heat or cool speed after the selected Fan On Delay time expires. The fan returns to circulating speed after the selected Fan Off Delay time expires following loss of the Heating or Cooling request.

## **Heating (W1) Request (single stage thermostat operation, 4th DIP switch on fan timer, must be in off position) (see furnace wiring diagram):**

24 VAC signals applied to W1 terminal of EFT control.

- Inducer motor turns on at high speed.
- The high fire solenoid energizes.
- Following a 3 second prepurge delay, the pilot valve opens and the igniter begins to warm up.
- After the pilot lights, the main burners energize and light (burners now at high fire rate).
- Timed from the opening of the main gas valve, the control will delay the selected Heat Fan On Delay time before switching the inducer to low speed, de-energizing the high fire solenoid and the fan switches to Low Heat speed.
- Timed from initial application of the Heating request, if the W1 request is still present after the Low Fire Delay time expires (12 minutes), the inducer switches to high speed, the high fire solenoid energizes and the fan switches to High Heat speed.

W1 signal removed from EFT.

- The gas valve de-energizes and the main burners go out.
- The inducer runs at its present speed for a 5 second postpurge period.
- The fan switches to (or stays at) Low Heat speed.
- Timed from the gas valve de-energizing, the Low Heat fan speed de-energizes after the selected Heat Fan Delay time expires.

NOTE4) If a new Heating request arrives while the control is waiting in the Heat Fan Off Delay time, the fan speed switches to High Heat until the Heat Fan Off Delay expires or the Heat Fan On Delay expires for the new Heating request.

## **Heating Request (two stage thermostat operation, 4th DIP switch must be in on position) (see furnace wiring diagram):**

24 VAC signals applied to W1 terminal of EFT control.

- Same response as single stage thermostat operation described above except the control will not go to high fire, High Heat fan speed unless a W2 signal is applied.

24 VAC signals applied to W1 and W2 terminals of EFT control.

- Same light-off routine as described for the signal stage thermostat operation except that at the end of the selected Heat Fan On Delay, the inducer remains on high fire, the high fire solenoid remains energized and the High Heat fan speed energizes.

NOTE5) The EFT control responds without delay to the presence or loss of W2 (with W1 constant). W1 & W2 results in high inducer, high fire and High Heat fan speed. W1 only results in low inducer, low fire and Low Heat fan speed.

## **Heating Request with Gas Supply Line Shut Off:**

24 VAC signals applied to W1 terminal of EFT control.

- Inducer motor turns on at high speed.
- The high fire solenoid energizes.
- Following a 3 second prepurge delay, the pilot valve opens and the igniter begins to warm up.
- The igniter glows red-hot for 30 seconds, then turns off.
- The igniter stays off for 25 seconds, then begins to warm-up again.
- The igniter glows red-hot for 30 seconds, then turns off.
- The pilot valve closes 3 seconds after the igniter de-energizes.
- The inducer de-energizes 5 seconds after the pilot valve closes.
- The SmartValve proceeds to soft lockout and flashes error code 6.
- The control exits soft lockout after 5 minutes and begins another ignition sequence.



## Gas Valve Diagnostic Codes (See Figure 30)

- Steady Flash = Normal Operation
- 2 Flashes = Low Pressure Switch Stuck Closed
- 3 Flashes = Low Pressure Switch Stuck Open or Manual ON/OFF Switch in OFF Position or (Aux. Limit Switch Open - Upflow ONLY)
- 4 Flashes = Limit Switch Open (Aux. Limit Switch Open - Downflow ONLY)
- 5 Flashes = Flame Sensed Out of Sequence
- 6 Flashes = Control in Soft Lockout (Automatic Restart or Retry Delay)
- 8 Flashes = High Pressure Switch Stuck Closed
- 9 Flashes = High Pressure Switch Stuck Open

Figure 30

Typical Gas Valve Honeywell

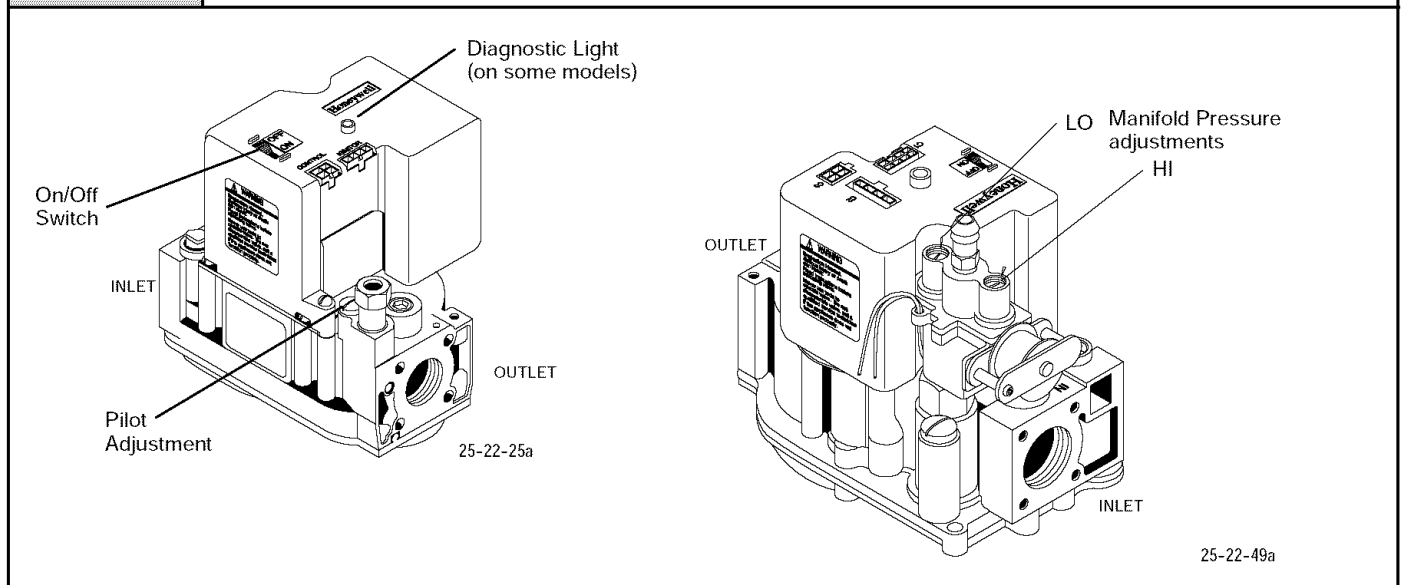

# Technical Support Manual

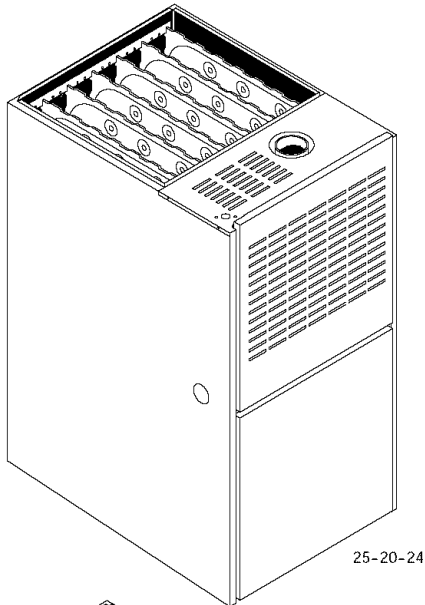

## Upflow Models

NTV6050FBG1	VNE050B12G1
NTV6075GFG1	VNE075F14G1
NTV6100KJG1	VNE100J20G1
NTV6125KJG1	VNE125J20G1
NTP6050FBG1	TNE050B12G1
NTP6075GFG1	TNE075F14G1
NTP6100GFG1	TNE100F14G1
NTP6100KJG1	TNE100J20G1
NTP6125KJG1	TNE125J20G1

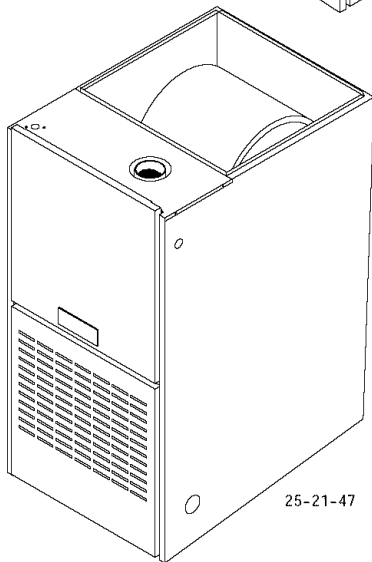

## Downflow Models

NDP6050FBG1	TDE050B12G1
NDP6075FBG1	TDE075B12G1
NDP6100HFG1	TDE100F16G1
NDP6125KJG1	TDE125J20G1

# FAN ASSISTED COMBUSTION GAS FURNACES



Manufactured by:  
*International Comfort Products Corporation (USA)*  
Lewisburg, TN USA 37091



Save This Manual For Future Reference

Manufacturers Number (Mfr No -See Rating Plate) ALL Models		
Specifications		
<b>General</b>		
Gas Type	Nat	LP
Transformer Size (VA)	40	40
T'stat Heat Anticipator	.30	.30
<b>Gas &amp; Ignition</b>		
Gas Valve	HW SV 9540	HW SV 9540
Regulation Type	SNAP	SNAP
Manifold Press. Hi Fire (" WC)	3.5	10.0
Lo Fire (" WC)	1.7	4.9
Pilot Orifice Size	.018	.011
Ignition Type/Series	HW HSP	HW HSP
<b>Combustion</b>		
Flue Outlet Size (Inches)	3	3
Std. Outlet Temp (°F)	<480	<480
<b>Limits &amp; Controls</b>		
Fan Control (Type)	HW ST9162A	HW ST9162A
Fan Control On	30/60	30/60
(Timed-secs) Off	60,100,140,180	60,100,140,180
<b>Gas Conversion Kits</b>		
Nat to LP	*1011789	
LP to Nat	*1011787	
*Must be ordered from Service Parts		

Specifications									
	NTV6050FB/ VNE050B12		NTV6075GF/ VNE075F14		NTV6100KJ/ VNE100J20		NTV6125KJ/ VNE125J20		
<b>General</b>									
Input (Btuh) Std/Alt.	Hi Fire	50,000	75,000	100,000	125,000				
	Lo Fire	35,000	52,500	70,000	87,000				
Output (Btuh) Std/Alt.	Hi Fire	40,000	60,000	79,000	89,000				
	Lo Fire	28,000	42,000	56,000	72,000				
Temp. Rise (°F)	Hi Fire	35-65	35-65	45-75	40-70				
	Lo Fire	35-65	35-65	45-75	40-70				
Electrical (Volts/Hz/FLA)	115/60/5.3		115/60/9.2		115/60/12		115/60/12		
<b>Gas &amp; Ignition</b>									
Gas Type	Nat	LP	Nat	LP	Nat	LP	Nat	LP	
Std. Main Orifices (No/Size)	2/#42	2/#54	3/#42	3/#54	4/#42	4/#54	5/#42	5/#54	
<b>Limits &amp; Controls</b>									
Thermal Sensor (°F)	300		300		300		300		
Limit Control Setting (°F)	See Limit in Parts List		See Limit in Parts List		See Limit in Parts List		See Limit in Parts List		
Auxiliary Limit (°F)	130		130		130		130		
Std. Pressure Sw. Hi Fire (Part No)	1010945		1010945		1010945		1010945		
Press (Close)	-0.95		-0.95		-0.95		-0.95		
Press (Open)	-0.80		-0.80		-0.80		-0.80		
Std. Pressure Sw. Lo Fire (Part No)	1011739		1011739		1011739		1011739		
Press (Close)	-0.53		-0.53		-0.53		-0.53		
Press (Open)	-0.35		-0.35		-0.35		-0.35		
<b>Blower Data</b>									
Type & Size	10-8		10-10		11-10		11-10		
Motor Amps/Rpm	4.6/1050		6.8/1050		9.8/900		9.8/900		
Motor Type/H.p.	DC/1/2		DC/1/2		DC/1		DC/1		
Filter Type	Washable		Washable		Washable		Washable		
Filter Size (")	14x25x1/2		16x25x1/2		16x25x1/2 (2)		16x25x1/2 (2)		
Min. Cool Cap. (Tons)	1.5		1.5		3		3		
Max. Cool Cap. (Tons)	3		3.5		5		5		

# Circulation Air Blower Data - NTV6/VNE

## Heating, Cooling & Continuous Airflow Settings

Continuous Blower (CFM) @ 0.10" Static

Switch Settings		Furnace Model		
#1	#2	50K	75K	100/125K
0*	0*	600	540	1000
0	1	730	660	1260
1	0	870	780	1500
1	1	1000	900	1725

\*Factory Setting

Heating Air Temperature Adjustment (° F)\*

Switch Settings			Furnace Model		
#3	#4	#5	50K	75K	100/125K
0**	0**	0**	0	0	0
0	0	1	2	3	3
0	1	0	4	7	7
0	1	1	6	12	11
1	0	0	9	14	14
1	0	1	-4	-4	-5
1	1	0	-7	-9	-8
1	1	1	-6	-13	-13

\*Approximate air temperature change from factory setting @ 0.20" static on high heat (low heat speed changes with change of high heat speed on most settings)

\*\*Factory setting

Cooling (CFM) @ 0.50" Static  
(See Figure 1 - 3 for complete Airflow Range)

Switch Settings			Furnace Model		
#6	#7	#8	50K	75K	100/125K
0*	0*	0*	1200	1350	2100
0	0	1	1100	1200	2000
0	1	0	1000	1100	1800
0	1	1	900	1000	1600
1	0	0	800	900	1400
1	0	1	700	800	1200
1	1	0	650	600	1000
1	1	1	550	550	800

\*Factory setting

### Blower Motor Settings

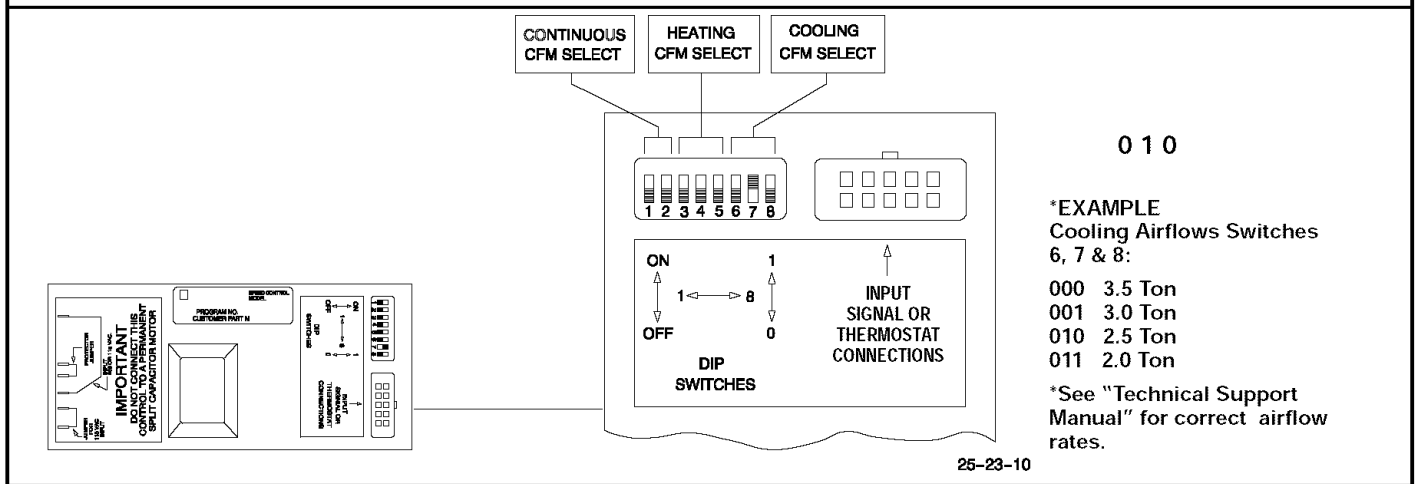

# Circulation Air Blower Data - NTV6/VNE

## Heating, Cooling & Continuous Airflow Settings

Figure 1

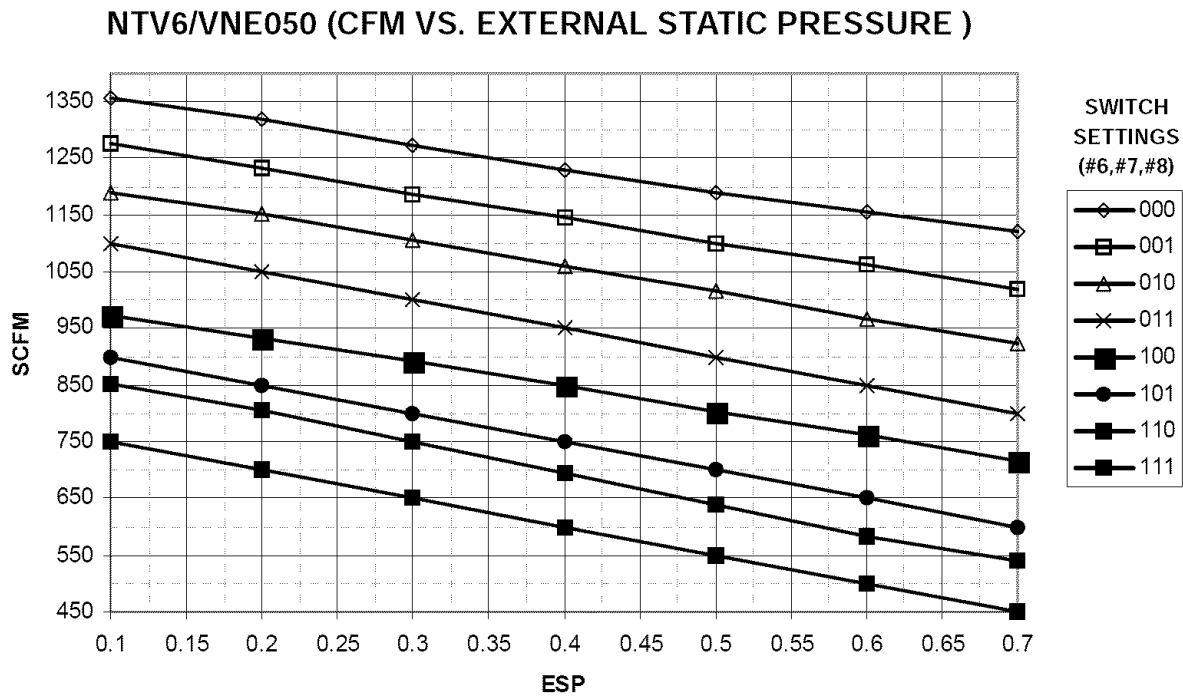
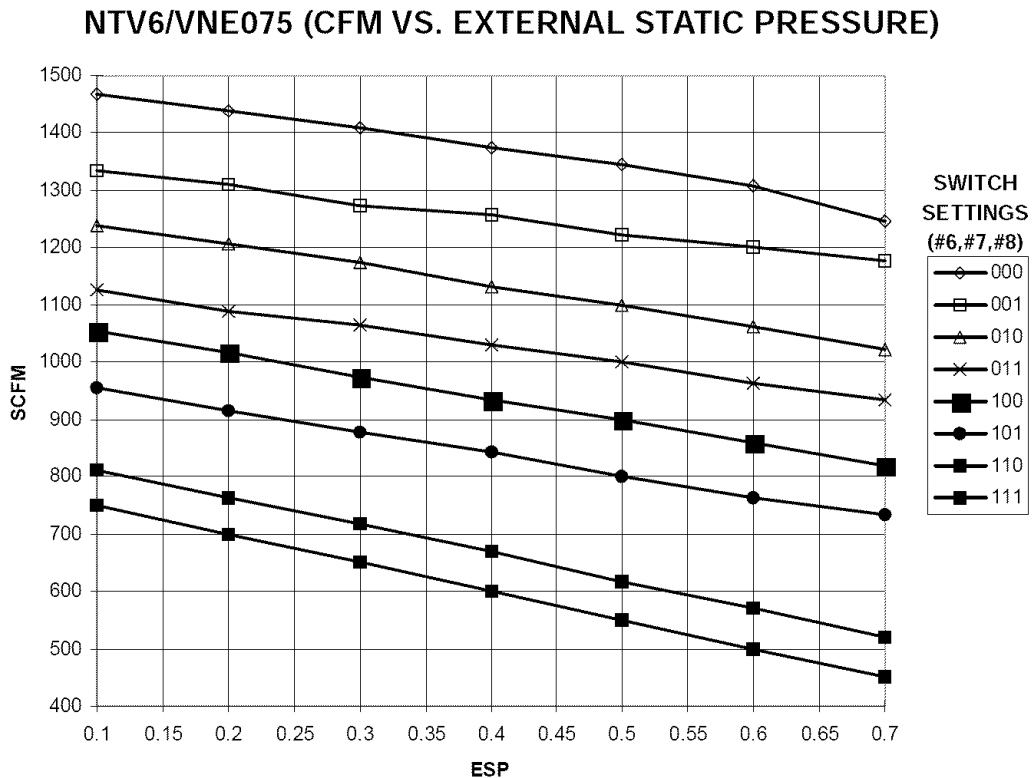

Figure 2



# Circulation Air Blower Data - NTV6/VNE

## Heating, Cooling & Continuous Airflow Settings

Figure 3

### NTV6/VNE100/125 PRESSURE (CFM VS. EXTERNAL STATIC PRESSURE)

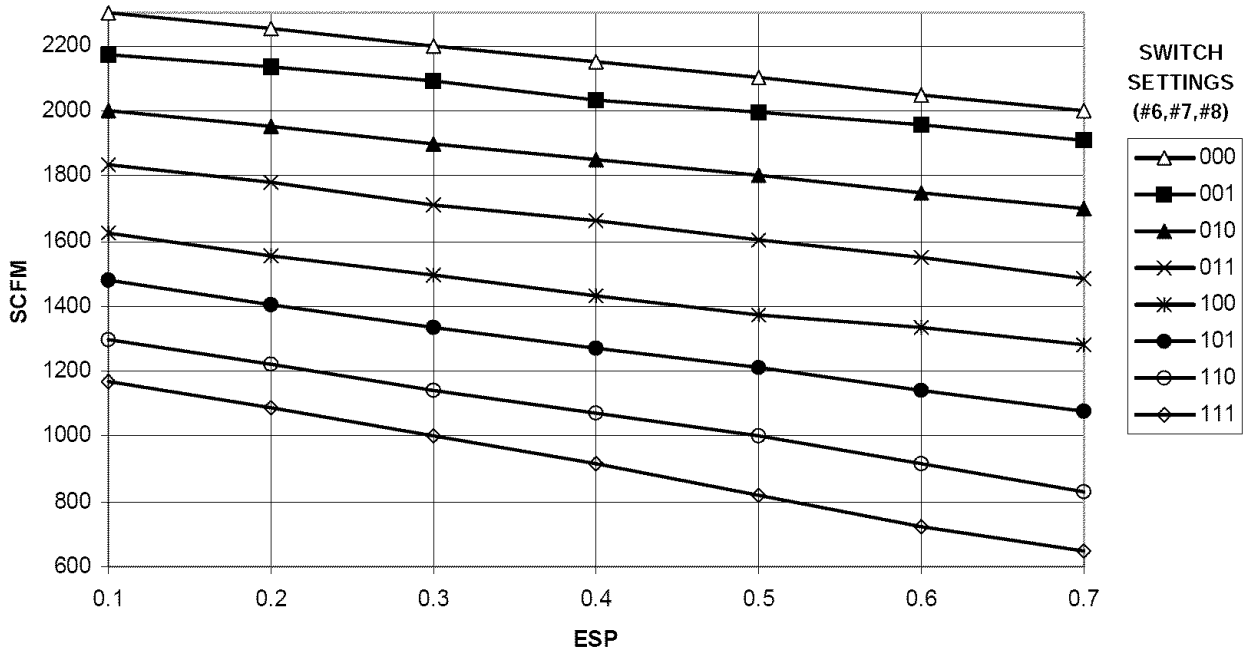

# Wiring Diagram (1/2 HP DC Blower Motor)

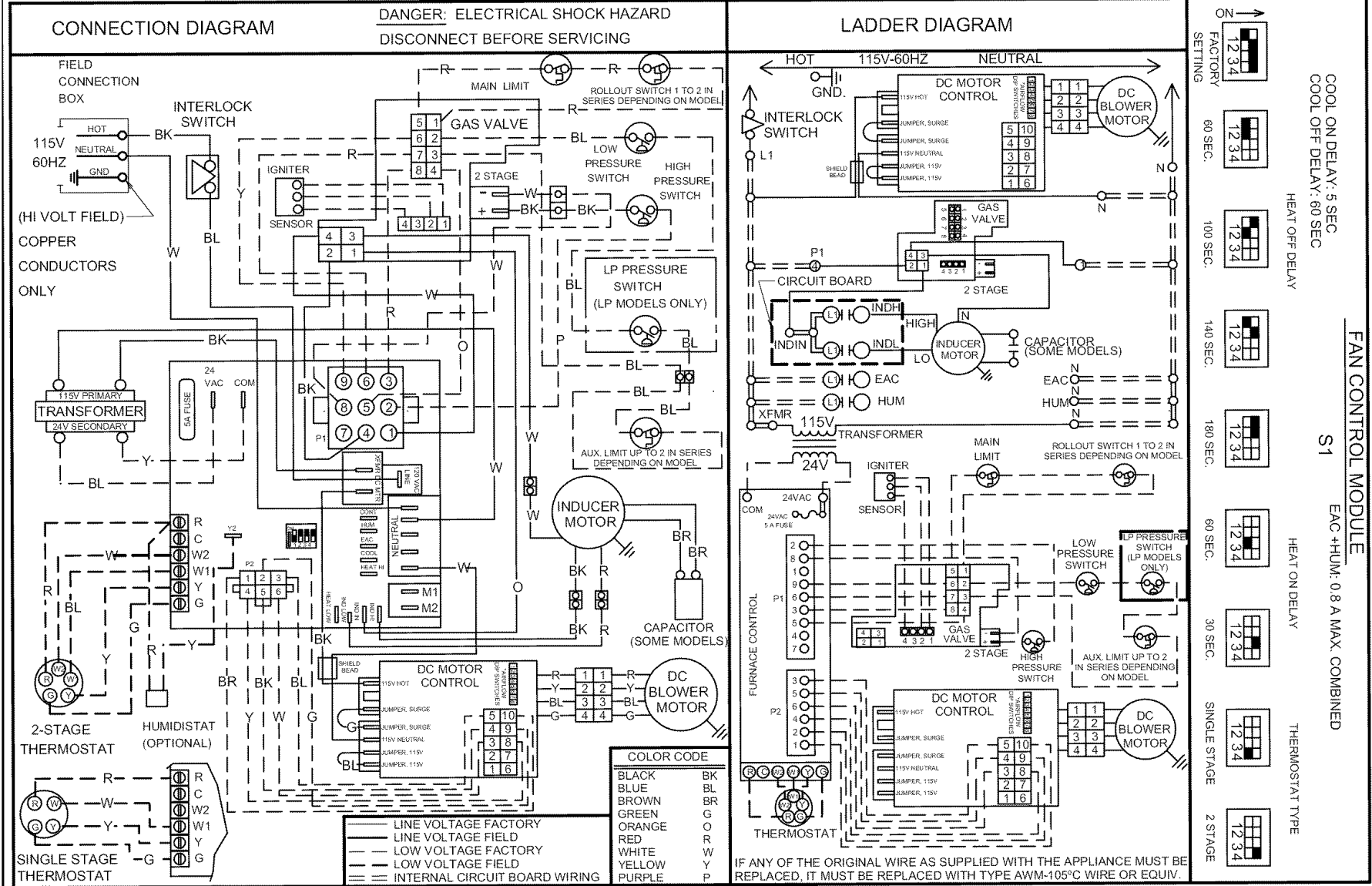

\* SEE MANUALS FOR ADJUSTING SWITCHES FOR PROPER HEATING, COOLING & CIRCULATING SPEEDS.

1012522-B

# Wiring Diagram (1 HP DC Blower Motor)

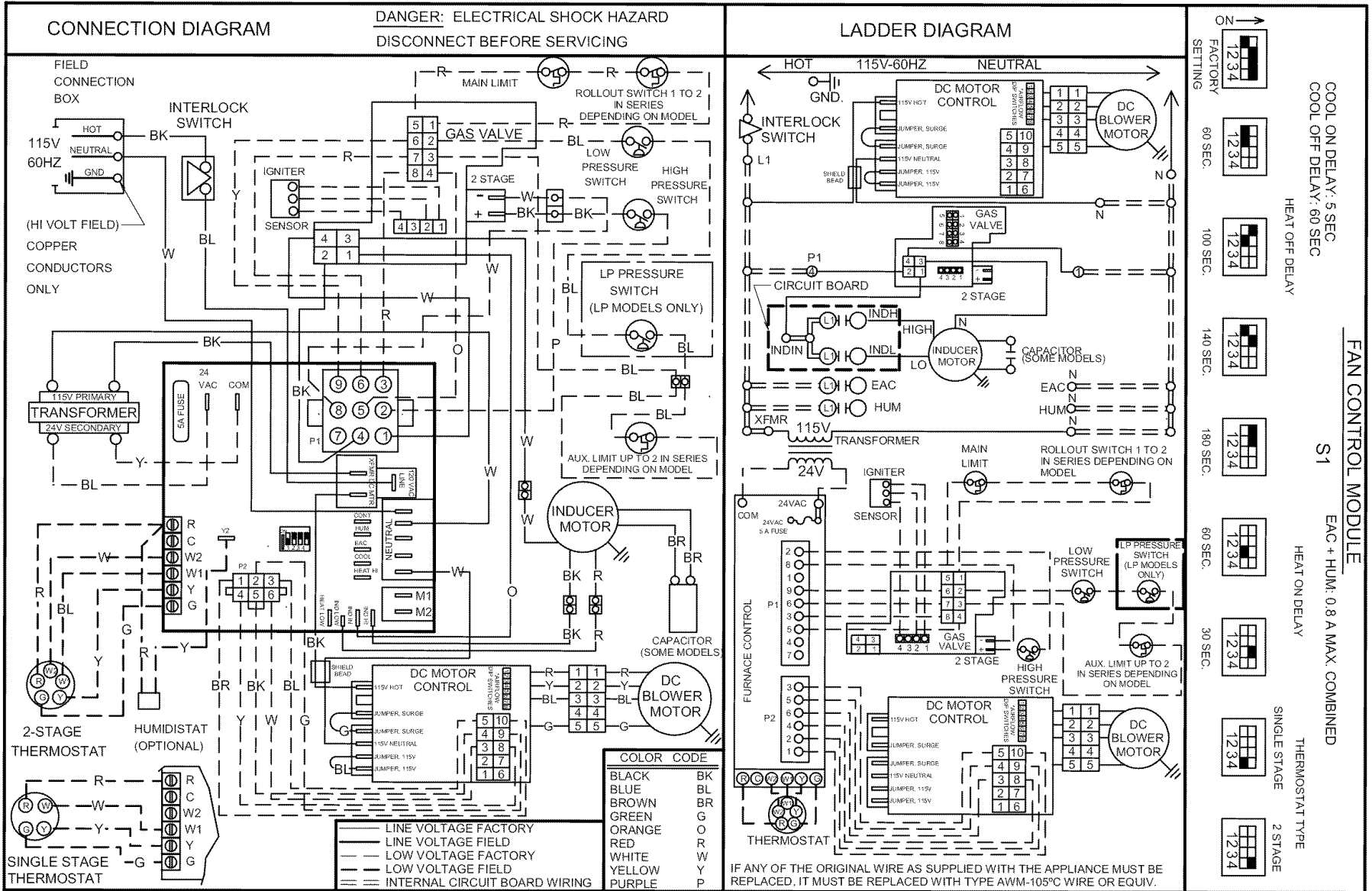



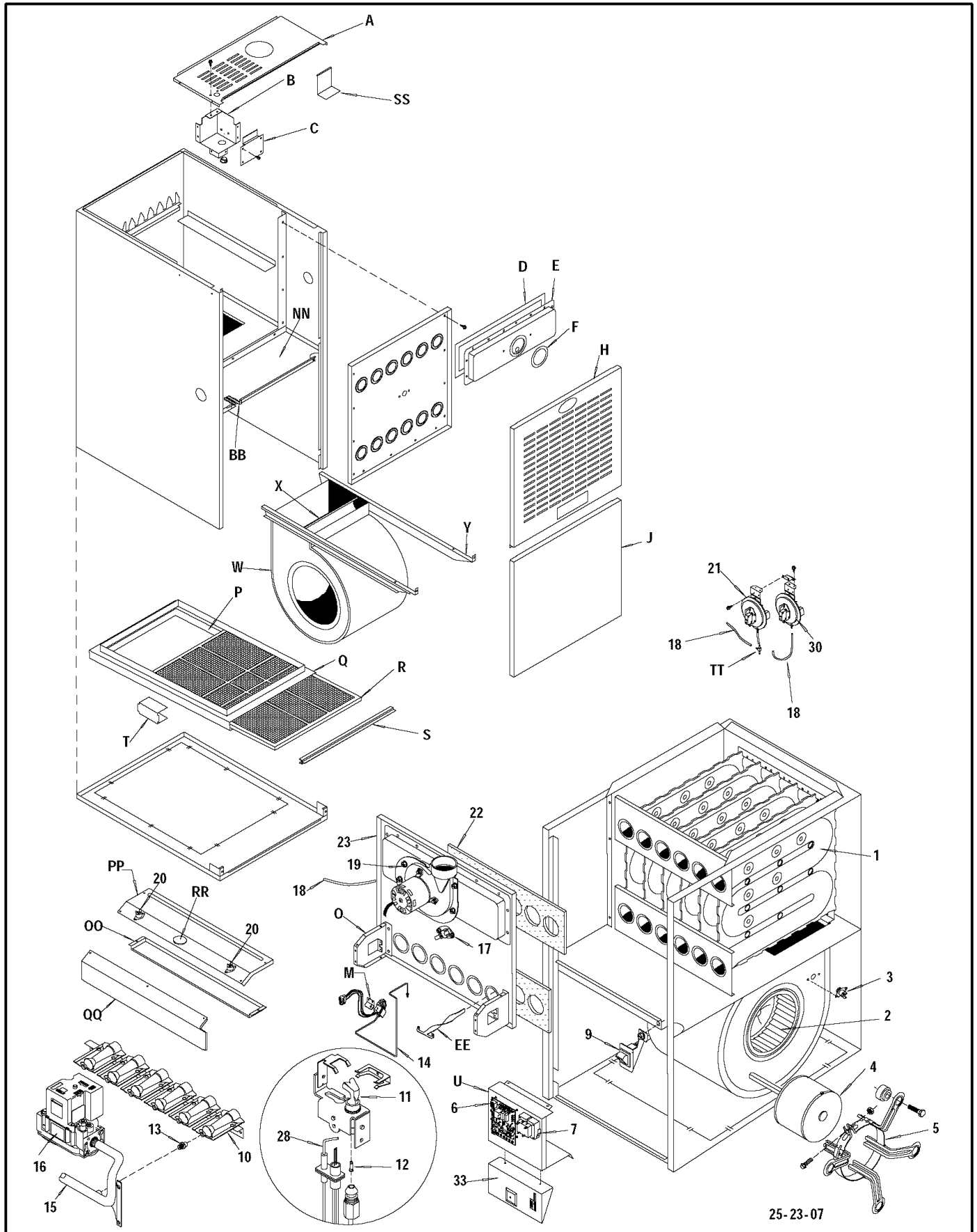

25-23-07

# Replacement Parts - NTV6/VNE (Natural Gas)

Models - NTV6050FBG1, NTV6075GFG1, NTV6100KJG1, NTV6125KJG1:  
VNE050B12G1, VNE075F14G1, VNE100J20G1 & VNE125J20G1

Replacement part supplied will be current active part. For parts not listed, consult place of purchase.

Key No.	Funcional Description	Part Number	NTV6/VNE				Key No.	Funcional Non-Description	Part Number	NTV6/VNE			
			050	075	100	125				050	075	100	125
1	Heat Exchanger	1011544	1	-	-	-	E	Collector	1085400	1	-	-	-
		1011363	-	-	1	-			1011048	-	1	-	-
		1012407	-	1	-	-			1011672	-	-	1	-
		1012408	-	-	-	1			1011738	-	-	-	1
2	Blower Wheel	601210	-	1	-	-	F	Gasket, Comb. Blower	1011379	1	1	1	1
		600587	1	-	-	-	H	Door, Louvered	1013331	1	-	-	-
		1011420	-	-	1	1			1013332	-	1	-	-
3	Switch, Auxiliary Limit	1013105	2	2	2	2			1013333	-	-	1	1
4	Blower Motor	1012478	1	1	-	-	J	Door, Blower	1013303	1	-	-	-
		1012479	-	-	1	1			1013304	-	1	-	-
5	Motor Mount Kit	1066700	1	1	-	-			1013305	-	-	1	1
		522020024	-	-	1	1	M	Bracket, Pilot	1010901	1	1	1	1
6	Control, Fan Timer	1012084	1	1	1	1	O	Manifold Supt Bracket	1011450	2	2	2	2
7	Transformer, 40VA	1012722	1	1	1	1	P	Filter Rack Wrapper	741010042	1	-	-	-
9	Switch Door	1010886	1	1	1	1			741010039	-	1	2	2
10	Burner Assembly	1008723	1	-	-	-	Q	Filter Rack Front	741020004	1	-	-	-
		1008724	-	1	-	-			741020001	-	1	2	2
		1008725	-	-	1	-	R	Filter 14" x 25" x 1/2"	1010364	1	-	-	-
		1008726	-	-	-	1			1010365	-	1	2	2
							S	Filter Cover Plastic	2791042	1	-	-	-
11	Pilot/Igniter	1008731	1	1	1	1			2791043	-	1	2	2
12	Pilot Orifice, NAT (.018)	503211	1	1	1	1	T	Clip, Filter	1008482	3	3	3	3
13	Orifice, #42 NAT	1011351	2	3	4	5	U	Fan Timer Bracket	1012462	1	1	1	1
14	Tube, Pilot	1011943	1	-	-	-	W	Blower Housing	1013131	1	-	-	-
		1011944	-	1	1	-			1013132	-	1	-	-
		1011946	-	-	-	1			1013128	-	-	1	1
15	Manifold	1011698	1	-	-	-	X	Blower Cutoff	721020008	-	1	1	1
		1011699	-	1	-	-			721020013	1	-	-	-
		1011700	-	-	1	-	Y	Blower Hanger	1010690	2	2	2	2
		1011701	-	-	-	1	BB	Rail, Blower Slide	57059	2	2	2	2
16	Valve, Natural & LP	1012188	1	1	1	1	EE	Baffle, NOx	1009876	2	3	4	5
17	Switch, Limit 260°F	1320366	1	-	-	-	NN	Partition, Blower	1013456	1	-	-	-
	180°F	1008417	-	-	1	-			1013457	-	1	-	-
	230°F	1320361	-	1	-	-			1013461	-	-	1	1
	190°F	1008445	-	-	-	1	OO	Baffle, Burner Box	1011454	1	1	-	-
18	Tubing, Silicone	2071255	1	1	1	1			1011455	-	-	1	-
19	Combustion Blower Assembly	1011632	1	1	1	1			1011456	-	-	-	1
20	Rollout Switch, Limit	1005549	2	2	2	2	PP	Top, Burner Box	1011768	1	1	-	-
21	Switch, Pressure (HI)(Upper)	1010945	1	1	1	1			1011769	-	-	1	-
22	Heat Exchanger Gaskets	2480904	2	-	-	-			1011770	-	-	-	1
		2480905	-	2	-	-	QQ	Cover, Burner Box	1011469	1	1	-	-
		2480906	-	-	2	-			1011470	-	-	1	-
		2480907	-	-	-	2			1011471	-	-	-	1
23	Heat Exchanger Frt Partition	1008068	1	-	-	-	RR	Sight Glass	1011781	1	1	1	1
		1008071	-	-	1	-	SS	Bracket, Pressure Switch	1011611	1	1	1	1
		1012410	-	1	-	-	TT	Pressure Tap Tee	1011750	1	1	1	1
		1012411	-	-	-	1							
28	Ignitor/Sensor with clip	1009524	1	1	1	1	{	<b>PART NOT ILLUSTRATED</b>					
30	Switch, Pressure (LO)(Lower)	1011739	1	1	1	1	{	Wire Harness	1011858	1	1	1	1
33	Motor Control	1012472	1	-	-	-	{	Harness, Hi Volt Motor	1012521	1	1	1	1
		1012473	-	1	-	-	{	Lo Volt Motor	1012520	1	1	1	1
		1012475	-	-	1	1	{	Fuse, 5 Amp	1083348	1	1	1	1
							{	Manual, Homeowners	44102200105	1	1	1	1
							{	Manual, Installation & Tech	44101201601	1	1	1	1
							{	Gas Conve. Kit (Nat. to LP.)	1011789	1	1	1	1
							{	(LP. to Nat.)	1011787	1	1	1	1

	Funcional Non-Description	Part Number				
A	Top	1013295	1	-	-	-
		1013296	-	1	-	-
		1013298	-	-	1	1
B	Field Connect Box	1011941	1	1	1	1
C	Cover, Field Connect	1010360	1	1	1	1
D	Gasket, Collector	1093661	1	1	-	-
		1093662	-	-	1	-
		1093663	-	-	-	1

Manufacturers Number (Mfr No -See Rating Plate) ALL Models		
Specifications		
<b>General</b>		
Gas Type	Nat	LP
Transformer Size (VA)	40	40
T'stat Heat Anticipator	.30	.30
<b>Gas &amp; Ignition</b>		
Gas Valve	HW SV 9540	HW SV 9540
Regulation Type	SNAP	SNAP
Manifold Press. Hi Fire (" WC)	3.5	10.0
Lo Fire (" WC)	1.7	4.9
Pilot Orifice Size	.018	.011
Ignition Type/Series	HW HSP	HW HSP
<b>Combustion</b>		
Flue Outlet Size (Inches)	3	3
Std. Outlet Temp (°F)	<480	<480
<b>Limits &amp; Controls</b>		
Fan Control (Type)	HW ST9162A	HW ST9162A
Fan Control On	30/60	30/60
(Timed-secs) Off	60,100,140,180	60,100,140,180
<b>Gas Conversion Kits</b>		
Nat to LP	*1011789	
LP to Nat	*1011787	
*Must be ordered from Service Parts		

Specifications										
	NTP6050FB/ TNE050B12		NTP6075GF/ TNE075F14		NTP6100GF/ TNE100F14		NTP6100KJ/ TNE100J20		NTP6125KJ/ TNE125J20	
<b>General</b>										
Input (Btuh) Std/Alt.	Hi Fire 50,000 Lo Fire 35,000		75,000 52,500		100,000 70,000		100,000 70,000		125,000 87,500	
Output (Btuh) Std/Alt.	Hi Fire 40,000 Lo Fire 28,000		60,000 42,000		80,000 56,000		79,000 56,000		99,000 72,000	
Temp. Rise (°F)	Hi Fire 35-65 Lo Fire 35-65		25-55 25-55		45-75 45-75		35-65 35-65		40-70 40-70	
Electrical (Volts/Hz/FLA)	115/60/5.3		115/60/9.2		115/60/9.2		115/60/12		115/60/12	
<b>Gas &amp; Ignition</b>										
Gas Type	Nat	LP	Nat	LP	Nat	LP	Nat	LP	Nat	LP
Std. Main Orifices (No/Size)	2/#42	2/#54	3/#42	3/#54	4/#42	4/#54	4/#42	4/#54	5/#42	5/#54
<b>Limits &amp; Controls</b>										
Thermal Sensor (°F)	300		300		300		300		300	
Limit Control Setting (°F)	See Limit in Parts List		See Limit in Parts List		See Limit in Parts List		See Limit in Parts List		See Limit in Parts List	
Auxiliary Limit (°F)	130		130		130		130		130	
Std. Pressure Sw. Hi Fire (Part No)	1010945		1010945		1010945		1010945		1010945	
Press (Close)	-0.95		-0.95		-0.95		-0.95		-0.95	
Press (Open)	-0.80		-0.80		-0.80		-0.80		-0.80	
Std. Pressure Sw. Lo Fire (Part No)	1011739		1011739		1011739		1011739		1011739	
Press (Close)	-0.53		-0.53		-0.53		-0.53		-0.53	
Press (Open)	-0.35		-0.35		-0.35		-0.35		-0.35	
<b>Blower Data</b>										
Type & Size	10-8		10-10		10-10		11-10		11-10	
Motor Amps/Rpm	6.5/1050		6.5/1050		6.5/1050		11.0/900		11.9/900	
Motor Type/H.p.	PSC <sup>1</sup> / <sub>3</sub>		PSC <sup>1</sup> / <sub>2</sub>		PSC <sup>1</sup> / <sub>2</sub>		PSC <sup>3</sup> / <sub>4</sub>		PSC <sup>3</sup> / <sub>4</sub>	
Cap. Mfd/Volts	5/370		7.5/370		7.5/370		10/370		10/370	
Filter Type	Washable		Washable		Washable		Washable		Washable	
Filter Size (")	14x25x1		16x25x1		16x25x1		16x25x1 (2)		16x25x1 (2)	
Min. Cool Cap. (Tons)	1.5		1.5		1.5		3		3	
Max. Cool Cap. (Tons)	3		3.5		3.5		5		5	

Specifications									
		NDP6050FB/TDE050B12		NDP6075FB/TDE075B12		NDP6100HF/TDE100F16		NTP6125JB/TDE125J20	
<b>General</b>									
Input (Btuh) Std/Alt.	Hi Fire	50,000		75,000		100,000		125,000	
	Lo Fire	35,000		52,500		70,000		87,500	
Output (Btuh) Std/Alt.	Hi Fire	40,000		60,000		80,000		89,000	
	Lo Fire	28,000		42,000		56,000		72,000	
Temp. Rise (°F)	Hi Fire	30-60		40-70		35-65		45-75	
	Lo Fire	30-60		40-70		35-65		45-75	
Electrical (Volts/Hz/FLA)		115/60/5.3		115/60/9.2		115/60/12		115/60/12	
<b>Gas &amp; Ignition</b>									
Gas Type		Nat.		Nat.		Nat.		Nat.	
Std. Main Orifices (No/Size)		2/#42		3/#42		4/#42		5/#42	
		LP		LP		LP		LP	
		2/#54		4/#54		4/#54		5/#54	
<b>Limits &amp; Controls</b>									
Thermal Sensor (°F)		300		300		300		300	
Limit Control Setting (°F)		See Limit in Parts List		See Limit in Parts List		See Limit in Parts List		See Limit in Parts List	
Auxiliary Limit (°F)		110		110		110		110	
Std. Pressure Sw. Hi Fire (Part No)		1010945		1010945		1010945		1010945	
Press (Close)		-0.95		-0.95		-0.95		-0.95	
Press (Open)		-0.80		-0.80		-0.80		-0.80	
Std. Pressure Sw. Lo Fire (Part No)		1011739		1011739		1011739		1011739	
Press (Close)		-0.53		-0.53		-0.53		-0.53	
Press (Open)		-0.35		-0.35		-0.35		-0.35	
<b>Blower Data</b>									
Type & Size		10-8		10-12		10-10		11-10	
Motor Amps/Rpm		6.5/1050		6.5/1050		8.5/1050		11.9/900	
Motor Type/H.p.		PSC/1/3		PSC/1/3		PSC/1/2		PSC/3/4	
Cap. Mfd/Volts		5/370		5/370		10/370		10/370	
Filter Type		Washable		Washable		Washable		Washable	
Filter Size (")		16x18x1 (2)		16x18x1 (2)		16x18x1 (2)		16x18x1 (2)	
Min. Cool Cap. (Tons)		1.5		1.5		2		3	
Max. Cool Cap. (Tons)		3		3		4		5	

**CIRCULATION AIR BLOWER DATA**

**NTP6050FB/TNE050B12, NDP6050FB/TNE050B12 & NDP6075FB/TNE075B12**

External Static Pressure Inches of W.C.	Air Delivery in Cubic Feet per Minute (C.F.M.) (Furnace Rated @0.5" WC ESP)					
	TAP	LOW	MED L	MED	MED H	HIGH
	.10	675	859	--	1015	1394
	.20	662	846	--	999	1342
	.30	651	819	--	977	1289
	.40	636	795	--	952	1227
	.50	608	765	--	914	1163
	.60	564	735	--	870	1086
	.70	514	685	--	818	1002

External Static Pressure Inches of W.C.	Air Delivery in Liters Per Second (L/S) (Furnace Rated @0.5" WC ESP)					
	TAP	LOW	MED L	MED	MED H	HIGH
	.10	318	405	--	479	658
	.20	312	399	--	472	633
	.30	307	387	--	461	608
	.40	300	375	--	449	579
	.50	287	361	--	431	549
	.60	266	347	--	411	513
	.70	243	323	--	386	473

**NTP6075GF/TNE075F14 & NTP6100GF/TNE100F14**

External Static Pressure Inches of W.C.	Air Delivery in Cubic Feet per Minute (C.F.M.) (Furnace Rated @0.5" WC ESP)					
	TAP	LOW	MED L	MED	MED H	HIGH
	.10	815	1043	--	1324	1649
	.20	783	1030	--	1302	1616
	.30	755	1021	--	1280	1592
	.40	735	989	--	1255	1546
	.50	704	968	--	1218	1502
	.60	668	941	--	1171	1425
	.70	646	881	--	1100	1353

External Static Pressure Inches of W.C.	Air Delivery in Liters Per Second (L/S) (Furnace Rated @0.5" WC ESP)					
	TAP	LOW	MED L	MED	MED H	HIGH
	.10	385	492	--	625	778
	.20	370	486	--	615	763
	.30	356	482	--	604	751
	.40	347	467	--	592	730
	.50	332	457	--	575	709
	.60	315	444	--	553	673
	.70	305	415	--	519	639

**NTP6100KJ/TNE100J20**

External Static Pressure Inches of W.C.	Air Delivery in Cubic Feet per Minute (C.F.M.) (Furnace Rated @0.5" WC ESP)					
	TAP	LOW	MED L	MED	MED H	HIGH
	.10	1210	1441	--	1773	2104
	.20	1201	1430	--	1740	2078
	.30	1197	1453	--	1740	2061
	.40	1191	1441	--	1718	2020
	.50	1167	1425	--	1707	2005
	.60	1160	1390	--	1676	1953
.70	1130	1365	--	1654	1917	

External Static Pressure Inches of W.C.	Air Delivery in Liters Per Second (L/S) (Furnace Rated @0.5" WC ESP)					
	TAP	LOW	MED L	MED	MED H	HIGH
	.10	571	680	--	837	993
	.20	567	675	--	821	981
	.30	565	686	--	821	973
	.40	562	680	--	811	953
	.50	552	673	--	806	946
	.60	548	656	--	791	922
.70	533	644	--	781	905	

**NTP6125KJ/TNE125J20**

External Static Pressure Inches of W.C.	Air Delivery in Cubic Feet per Minute (C.F.M.) (Furnace Rated @0.5" WC ESP)					
	TAP	LOW	MED L	MED	MED H	HIGH
	.10	1264	1520	--	1841	2161
	.20	1251	1506	--	1803	2132
	.30	1249	1486	--	1772	2079
	.40	1219	1456	--	1736	2042
	.50	1168	1427	--	1702	1991
	.60	1178	1415	--	1672	1914
.70	1143	1358	--	1614	1838	

External Static Pressure Inches of W.C.	Air Delivery in Liters Per Second (L/S) (Furnace Rated @0.5" WC ESP)					
	TAP	LOW	MED L	MED	MED H	HIGH
	.10	597	717	--	869	1020
	.20	590	711	--	851	1006
	.30	590	701	--	836	981
	.40	575	687	--	819	964
	.50	551	674	--	803	940
	.60	556	668	--	789	903
.70	540	641	--	762	868	

**NDP6100HF/TDE100F16**

External Static Pressure Inches of W.C.	Air Delivery in Cubic Feet per Minute (C.F.M.) (Furnace Rated @0.5" WC ESP)					
	TAP	LOW	MED L	MED	MED H	HIGH
	.10	954	1312	--	1698	1925
	.20	950	1292	--	1645	1853
	.30	946	1265	--	1596	1780
	.40	915	1231	--	1530	1708
	.50	878	1175	--	1455	1638
	.60	830	1118	--	1362	1546
.70	778	1020	--	1241	1435	

External Static Pressure Inches of W.C.	Air Delivery in Liters Per Second (L/S) (Furnace Rated @0.5" WC ESP)					
	TAP	LOW	MED L	MED	MED H	HIGH
	.10	450	619	--	801	908
	.20	448	610	--	776	874
	.30	446	597	--	753	840
	.40	432	581	--	722	806
	.50	414	555	--	687	773
	.60	392	528	--	643	730
.70	367	481	--	586	677	

**NDP6125KJ/TDE125J20**

External Static Pressure Inches of W.C.	Air Delivery in Cubic Feet per Minute (C.F.M.) (Furnace Rated @0.5" WC ESP)					
	TAP	LOW	MED L	MED	MED H	HIGH
	.10	1333	1573	--	1840	2148
	.20	1294	1544	--	1816	2093
	.30	1266	1500	--	1776	2041
	.40	1240	1467	--	1726	1981
	.50	1175	1419	--	1665	1906
	.60	1141	1357	--	1607	1828
.70	1054	1308	--	1538	1751	

External Static Pressure Inches of W.C.	Air Delivery in Liters Per Second (L/S) (Furnace Rated @0.5" WC ESP)					
	TAP	LOW	MED L	MED	MED H	HIGH
	.10	629	742	--	868	1014
	.20	611	729	--	857	988
	.30	598	708	--	838	963
	.40	585	692	--	815	935
	.50	555	670	--	786	900
	.60	539	641	--	759	863
.70	497	617	--	726	826	

CONNECTION DIAGRAM

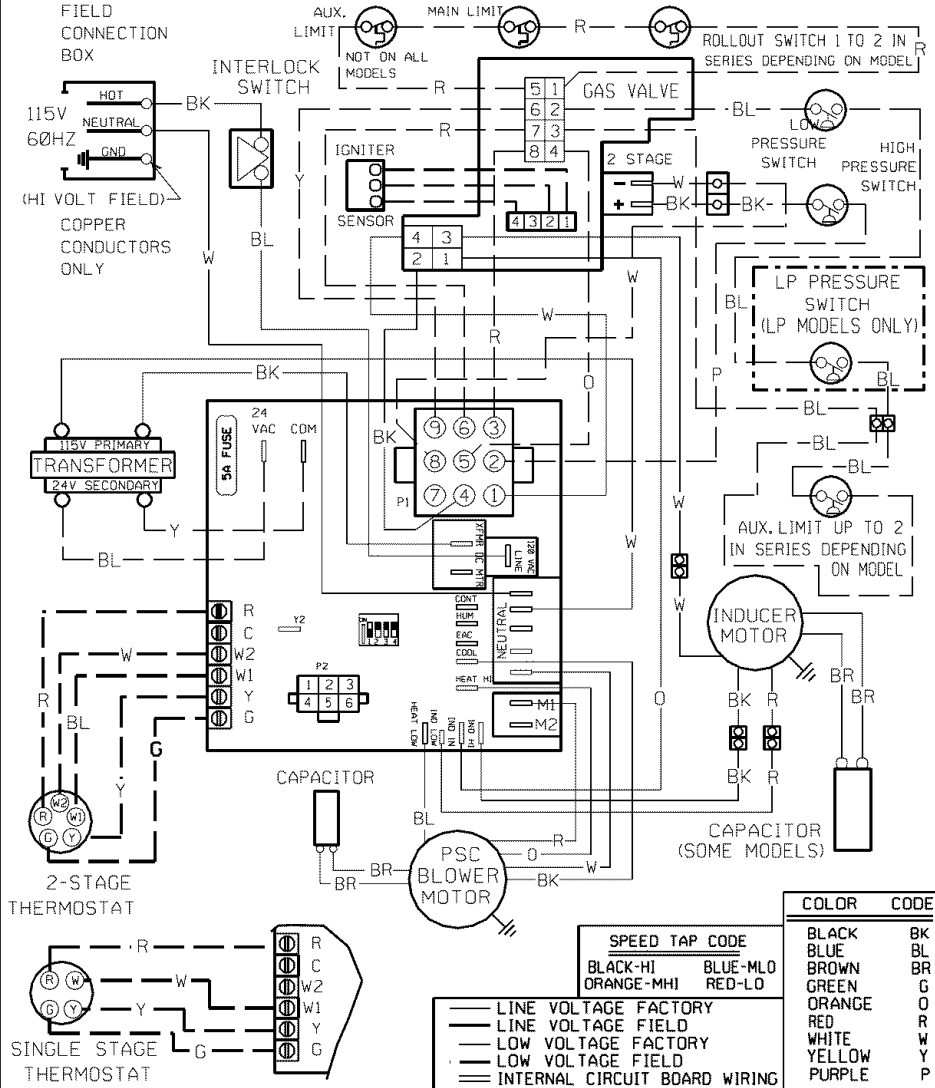

LADDER DIAGRAM

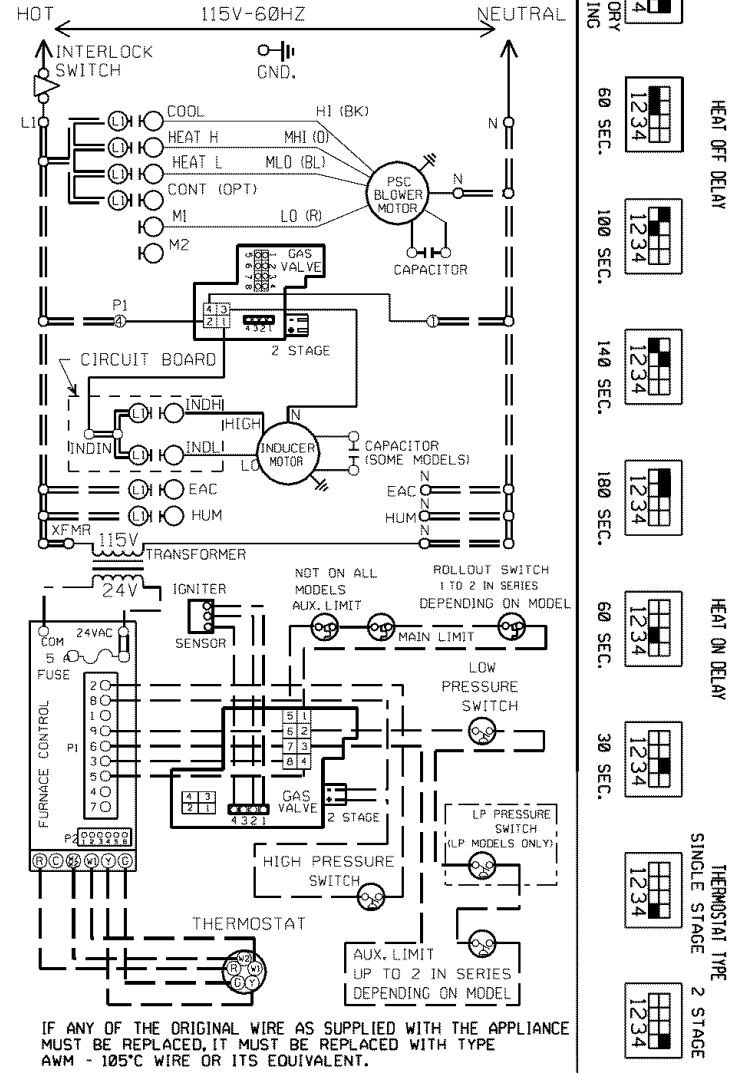

IF ANY OF THE ORIGINAL WIRE AS SUPPLIED WITH THE APPLIANCE MUST BE REPLACED, IT MUST BE REPLACED WITH TYPE AWG - 105°C WIRE OR ITS EQUIVALENT.

\* SEE MANUALS FOR ADJUSTING SPEED TAPS FOR PROPER HEATING, COOLING & CIRCULATING SPEEDS.

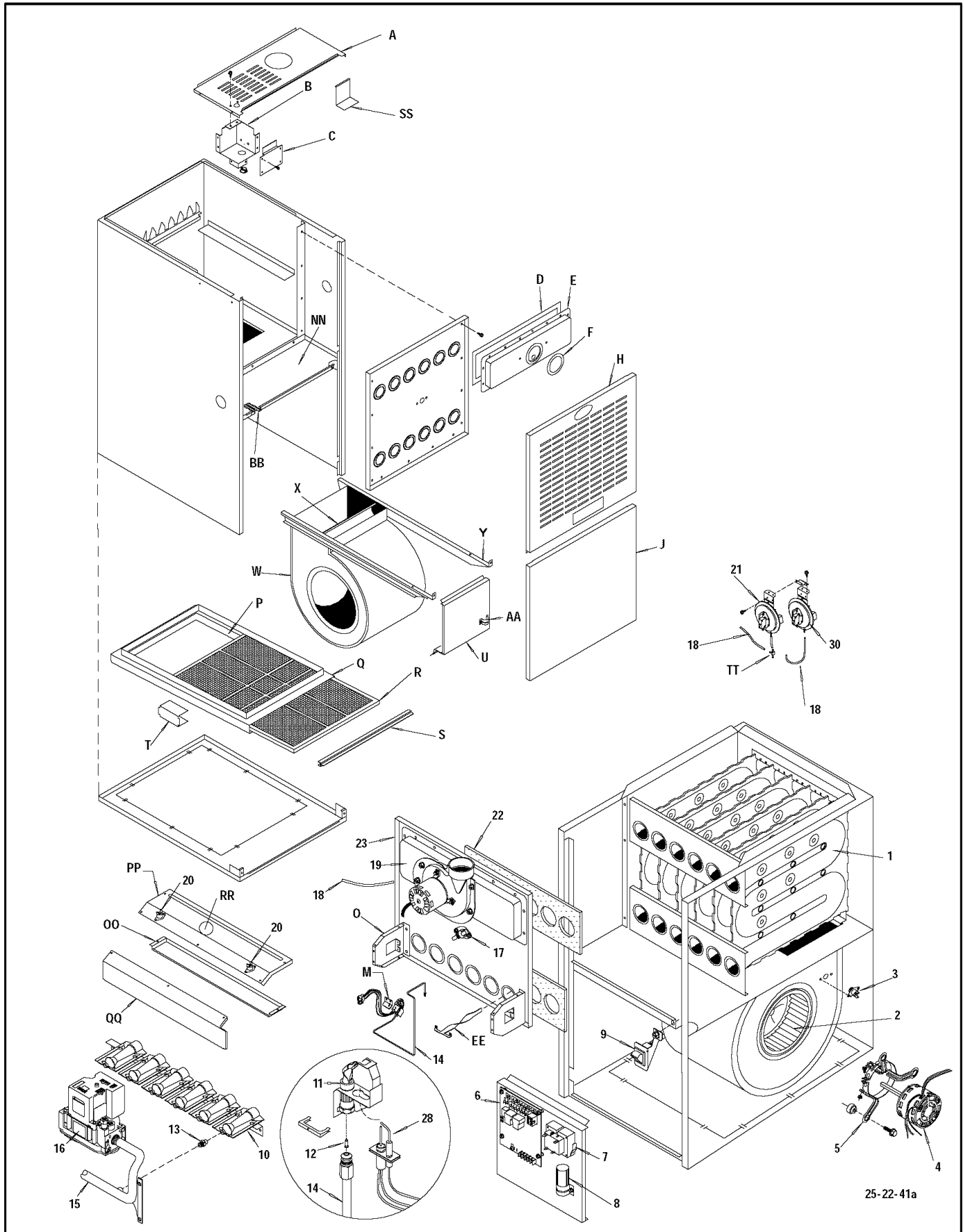

# Replacement Parts - NTP6/TNE (Natural Gas)

Models - NTP6050FBG1, NTP6075GFG1, NTP6100GFG1, NTP6100KJG1, NTP6125KJG1:  
TNE050B12G1, TNE075F14G1, TNE100F14G1, TNE100J20G1 & TNE125J20G1

Replacement part supplied will be current active part. For parts not listed, consult place of purchase.

Key No.	Functional Description	Part Number	NTP6/TNE					Key No.	Functional Description	Part Number	NTP6/TNE				
			050F 050B	075G 075F	100G 100F	100K 100J	125K 125J				050F 050B	075G 075F	100G 100F	100K 100J	125K 125J
1	Heat Exchanger	1011544	1	-	-	-	-	A	Top	1013295	1	-	-	-	-
		1011364	-	-	1	-	-			1013296	-	1	-	-	-
		1011363	-	-	-	1	-			1013297	-	-	1	-	-
		1012407	-	1	-	-	-			1013298	-	-	-	1	1
		1012408	-	-	-	-	1								
2	Blower Wheel	601210	-	1	1	-	-	B	Field Connect Box	1011941	1	1	1	1	1
		600587	1	-	-	-	-	C	Cover, Field Connect	1010360	1	1	1	1	1
		1011420	-	-	-	1	1	D	Gasket, Collector	1093661	1	1	-	-	-
3	Switch, Auxiliary Limit	1013105	2	2	2	2	2			1093662	-	-	1	-	-
4	Blower Motor	1012514	1	-	-	-	-	E	Collector	1085400	1	-	-	-	-
		1013341	-	1	1	-	-			1011048	-	1	-	-	-
		1011404	-	-	-	1	1			1011672	-	-	1	1	-
5	Motor Mount Kit	609227	1	1	1	-	-			1011738	-	-	-	-	1
		522020024	-	-	-	1	1	F	Gasket, Combustion Blwr	1011379	1	1	1	1	1
6	Control, Fan Timer	1012084	1	1	1	1	1	H	Door, Louvered	1013331	1	-	-	-	-
7	Transformer, 40VA	1012722	1	1	1	1	1			1013332	-	1	1	-	-
8	Capacitor 10mf 370V	1094956	-	-	-	1	1	J	Door, Blower	1013303	1	-	-	-	-
	5mf 370V	1094954	1	-	-	-	-			1013304	-	1	1	-	-
	7.5mf 370V	1094239	-	1	1	-	-			1013305	-	-	-	1	1
9	Switch Door	1010886	1	1	1	1	1	M	Bracket, Pilot	1010901	1	1	1	1	1
10	Burner Assembly	1008723	1	-	-	-	-	O	Manifold Support Bracket	1011450	2	2	2	2	2
		1008724	-	1	-	-	-	P	Filter Rack Wrapper	741010042	1	-	-	-	-
		1008725	-	-	1	1	-			741010039	-	1	1	2	2
		1008726	-	-	-	-	1	Q	Filter Rack Front	741020004	1	-	-	-	-
11	Pilot, Nat & LP	1008731	1	1	1	1	1			741020001	-	1	1	2	2
12	Pilot Orifice, NAT (.018)	503211	1	1	1	1	1	R	Filter 14" x 25" x 1/2"	1010364	1	-	-	-	-
13	Orifice, #42 NAT	1011351	2	3	4	4	5			1010365	-	1	1	2	2
14	Tube, Pilot	1011943	1	-	-	-	-	S	Filter Cover Plastic	2791042	1	-	-	-	-
		1011944	-	1	1	1	-			2791043	-	1	1	2	2
		1011946	-	-	-	-	1	T	Clip, Filter	1008482	3	3	3	3	3
15	Manifold	1011698	1	-	-	-	-	U	Fan Timer Bracket	1012321	1	1	1	1	1
		1011699	-	1	-	-	-	W	Blower Housing	1013131	1	-	-	-	-
		1011700	-	-	1	1	-			1013132	-	1	1	-	-
		1011701	-	-	-	-	1			1013128	-	-	-	1	1
16	Valve, Natural & LP	1012188	1	1	1	1	1	X	Blower Cutoff	721020008	-	1	1	1	1
17	Switch, Limit 260°F	1320366	1	-	-	-	-			721020013	1	-	-	-	-
	270°F	1320365	-	-	1	-	-	Y	Blower Hanger	1010690	2	2	2	2	2
	180°F	1008417	-	-	-	1	-	AA	Strap Capacitor	1095020	1	1	1	1	1
	150°F	1320361	-	1	-	-	-	BB	Rail, Blower Slide	57059	2	2	2	2	2
	190°F	1008445	-	-	-	-	1	EE	Baffle, NOx	1009876	2	3	4	4	5
18	Tubing, Silicone 24"	2971255	1	1	1	1	1	NN	Partition, Blower	1013456	1	-	-	-	-
19	Combustion Blw Assemb	1011632	1	1	1	1	1			1013457	-	1	1	-	-
20	Rollout Switch, Limit	1005549	2	2	2	2	2			1013461	-	-	-	1	1
21	Switch, Press (Hi)(Upper)	1010945	1	1	1	1	1	OO	Baffle, Burner Box	1011454	1	1	-	-	-
22	Heat Exchanger Gaskets	2480904	2	-	-	-	-			1011455	-	-	1	1	-
		2480905	-	2	-	-	-			1011456	-	-	-	-	1
		2480906	-	-	2	2	-	PP	Top, Burner Box	1011768	1	1	-	-	-
		2480907	-	-	-	-	2			1011769	-	-	1	1	-
23	Ht Exchanger Frit Partition	1008068	1	-	-	-	-			1011770	-	-	-	-	1
		1008072	-	-	1	-	-	QQ	Cover, Burner Box	1011469	1	1	-	-	-
		1008071	-	-	-	1	-			1011470	-	-	1	1	-
		1012410	-	1	-	-	-			1011471	-	-	-	-	1
		1012411	-	-	-	-	1	RR	Sight Glass	1011781	1	1	1	1	1
28	Ignitor/Sensor with clip	1009524	1	1	1	1	1	SS	Bracket, Pressure Swth	1011611	1	1	1	1	1
30	Switch, Press (Lo)(Lwr)	1011739	1	1	1	1	1	TT	Pressure Tap Tee	1011750	1	1	1	1	1
(	<b>PART NOT ILLUSTRATED</b>														
(	Wire Harn Asy. Low Volt	1011858	1	1	1	1	1								
(	Fuse, 5 Amp	1083348	1	1	1	1	1								
(	Manual, Homeowners	44102200105	1	1	1	1	1								
(	Manual, Installation& Tech	44101201601	1	1	1	1	1								
(	Nat to LP Conver Kit	1011789	1	1	1	1	1								
(	LP to Nat Conver Kit	1011787	1	1	1	1	1								



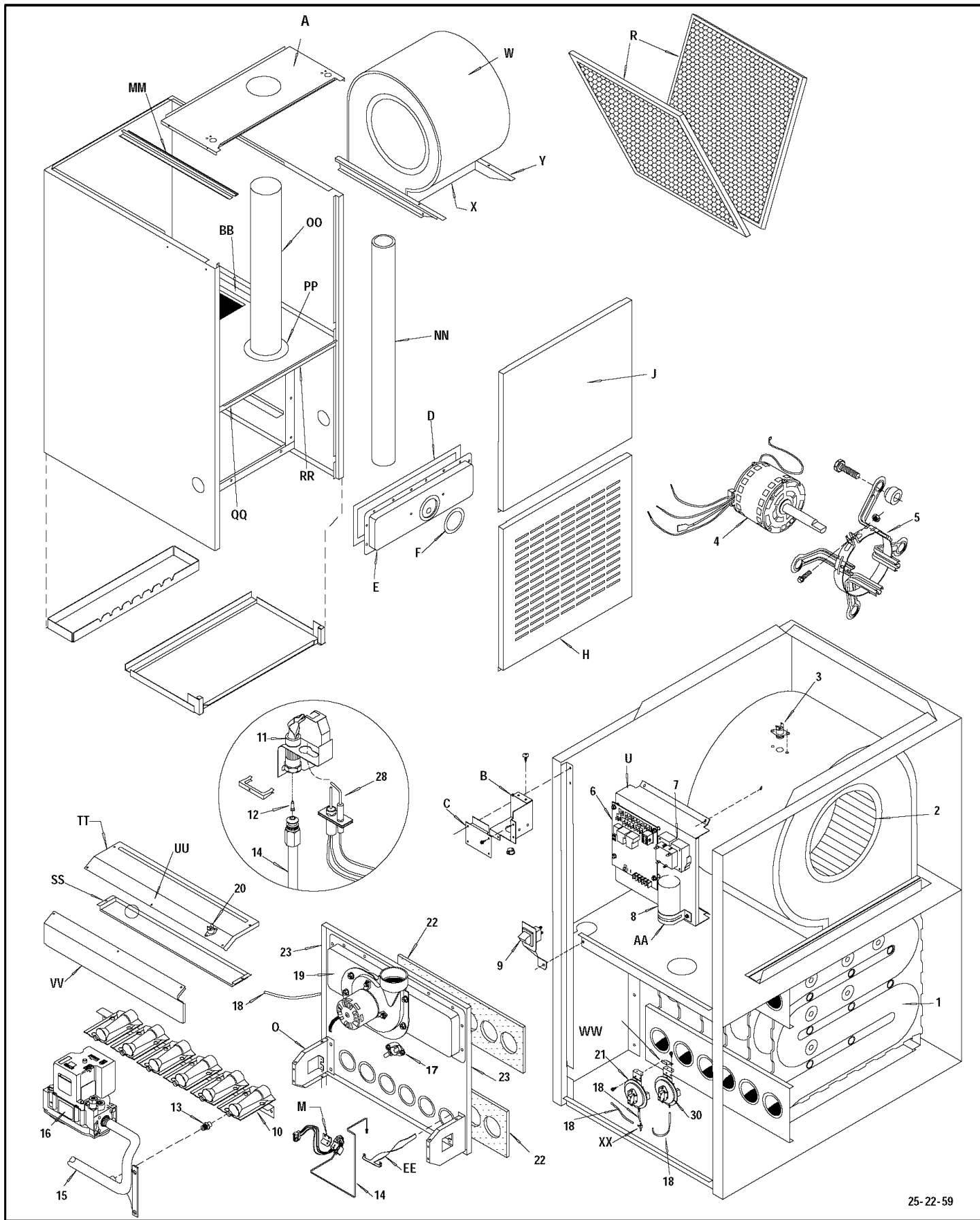

25-22-59

# Replacement Parts - NDP6/TDE (Natural Gas)

Models - NDP6050FBG1, NDP6075FBG1, NDP6100HFG1 & NDP6125KJG1:  
TDE050B12G1, TDE075F12G1, TDE100F16G1 & TDE125J20G1

Replacement part supplied will be current active part. For parts not listed, consult place of purchase.

Key No.	Description Functional	Part Number	NDP6/TDE				Key No.	Description Non-Functional	Part Number	NDP6/TDE			
			050F 050B	075F 075B	100H 100F	125K 125J				050F 050B	075F 075B	100H 100F	125K 125J
1	Heat Exch Assembly	1011544 1011364 1012406 1012408	1 - - -	- - 1 -	- 1 - -	- - - 1	A	Panel, Top	1013299 1013300 1013301	1 - -	1 - -	- 1 -	- - 1
2	Blower Wheel	601210 600587 1011420	- 1 -	- 1 -	1 - -	- - 1	B	Field Connect Box	1011941	1	1	1	1
3	Switch, Limit (Auxiliary)	1320368	1	1	1	1	C	Cover, Field Connect	1010360	1	1	1	1
4	Blower Motor	1012514 1009052 1011404	1 - -	1 - -	- 1 -	- - 1	D	Gasket, Collector	1093661 1093662 1093663	1 - -	1 - -	- 1 -	- - 1
5	Motor Mount Kit	609227 522020024	1 -	1 -	1 -	- 1	E	Collector	1085400 1011048 1011672 1011738	1 - - -	- 1 - -	- - 1 -	- - - 1
6	Control, Fan Timer	1012084	1	1	1	1	F	Gasket, Combustion Blwr	1011379	1	1	1	1
7	Transformer, 40VA	1012722	1	1	1	1	H	Door, Louvered	1013334 1013335 1013336	1 - -	1 - -	- - -	- - 1
8	Capacitor 10mf 370V 5mf 370V	1094956 1094954	- 1	- 1	1 -	1 -	J	Door, Blower	1013310 1013311 1013312	1 - -	1 - -	- 1 -	- - 1
9	Switch Door	1010886	1	1	1	1	M	Bracket, Pilot	1010901	1	1	1	1
10	Burner Assembly	1008723 1008724 1008725 1008726	1 - - -	- 1 - -	- - 1 -	- - - 1	O	Manifold Support Bracket	1011450	2	2	2	2
11	Pilot, Natural & LP	1008731	1	1	1	1	R	Filter 18 1/4" X 15 3/4" X 1"	1009750	2	2	2	2
12	Orifice, Pilot, Nat. (.018)	503211	1	1	1	1	U	Support, Control	1011178	1	1	1	1
13	Orifice, #42, Nat.	1011351	2	3	4	5	W	Blower Housing	1013129 1010579 1010580	- 1 -	- 1 -	- - 1	- - -
14	Tube, Pilot	1011943 1011944 1011946	1 - -	- 1 -	- 1 -	- - 1	X	Blower Cutoff	721020008 721020013	- 1	- 1	- -	- 1
15	Manifold	1011698 1011699 1011700 1011701	1 - - -	- 1 - -	- - 1 -	- - - 1	Y	Blower Hanger	33403100	2	2	2	2
16	Valve, Natural + LP	1012188	1	1	1	1	AA	Clamp, Capacitor	1095020	1	1	1	1
17	Switch, Limit 210°F 260°F 220°F 150°F	34335001 1320366 1320367 1320362	1 - - -	- - 1 -	- - - -	- - - 1	BB	Rail, Blower Slide	33406100	2	2	2	2
18	Tubing, Silicone, (24")	2971255	1	1	1	1	EE	NOx Baffle	1009876	2	3	4	5
19	Combustion Blwr Assb.	1011632	1	1	1	1	MM	Filter Holder	33411100	1	1	1	1
20	Rollout Switch, Limit	1005549	1	1	1	1	NN	Flue Pipe	613193	1	1	1	1
21	Switch, Press (Hi) (Upper)	1010945	1	1	1	1	OO	Vent Pipe Shield	2311160	1	1	1	1
22	Gasket, Heat Exchanger	2480904 2480905 2480906 2480907	2 - - -	- 2 - -	- - 2 -	- - - 2	PP	Vent Shield Endplate	57083	2	2	2	2
23	Partition, Frnt Ht Exch	1008068 1008072 1012409 1012411	1 - - -	- - 1 -	- - - -	- - - 1	QQ	Plate, Fill-in	1011071 1011072 1011073	1 - -	1 - -	- 1 -	- - 1
28	Ignitor/Sensor with clip	1009524	1	1	1	1	RR	Partition, Blower	1013476 1013474 1013475	1 - -	1 - -	- 1 -	- - 1
30	Switch, Press (Lo) (Lower)	1011739	1	1	1	1	SS	Baffle, Burner Box	1011454 1011455 1011456	1 - -	1 - -	- 1 -	- - 1
)	<b>PART NOT ILLUSTRATED</b>						TT	Top, Burner Box	1011772 1011773 1011774	1 - -	1 - -	- 1 -	- - 1
)	Wire Harness Asy.	1012202	1	1	1	1	UU	Sight Glass	1011781	1	1	1	1
)	Fuse, 5 Amp	1083348	1	1	1	1	VV	Cover, Burner Box	1011469 1011470 1011471	1 - -	1 - -	- 1 -	- - 1
)	Manual, Homeowners	44102200106	1	1	1	1	WW	Bracket, Press Switch	1011611	1	1	1	1
)	Manual, Installation & Tech	44101201601	1	1	1	1	XX	Tee, Plastic	1011750	1	1	1	1
)	Manual, Vent Inst	1007374	1	1	1	1							
)	Nat to LP Gas Conver Kit	1011789	1	1	1	1							
)	LP to Nat Gas Conver Kit	1011787	1	1	1	1							