

INSTALLATION INSTRUCTIONS

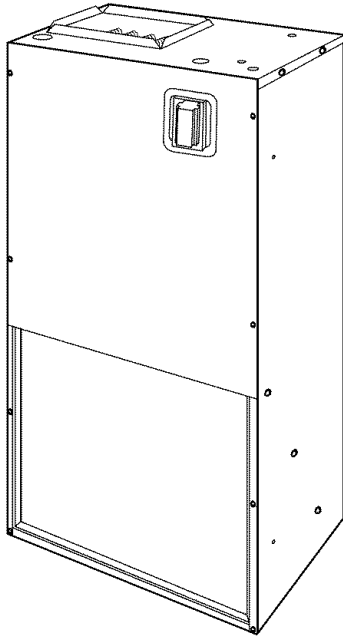

Apartment Air Handler

Use **ONLY** factory listed electric heaters.

Models

FWM1800A1*
FWM2400A1*
FWM3000A1*

FWM1805A1	FWM2405A1	FWM3005A1
FWM1807A1	FWM2407A1	FWM3007A1
FWM1811A1	FWM2411A1	FWM3011A1

*Requires
AMWK001CK1
Cooling Only Control Kit

Contents

General Information / Installation	2
Installations	3
Ductwork Connections	3
Condensate Drain	4
Orifice Sizing & Refrigerant Lines	4
Field Installation of Controls	5
Electrical Connections	5
Motor Speeds	6
Wiring Diagram	7
Replacement Parts	8

Safety Labeling and Signal Words

Danger, Warning and Caution

The signal words **DANGER**, **WARNING** and **CAUTION** are used to identify levels of hazard seriousness. The signal word **DANGER** is only used on product labels to signify an immediate hazard. The signal words **WARNING** and **CAUTION** will be used on product labels and throughout this manual and other manuals that may apply to the product.

DANGER - Immediate hazards which **WILL** result in severe personal injury or death.

WARNING - Hazards or unsafe practices which **COULD** result in severe personal injury or death.

CAUTION - Hazards or unsafe practices which **COULD** result in minor personal injury or product or property damage.

Signal Words in Manuals

The signal word **WARNING** is used throughout this manual in the following manner:

! WARNING

The signal word **CAUTION** is used throughout this manual in the following manner:

CAUTION

Product Labeling

Signal words are used in combination with colors and/or pictures on product labels.

Figure 1

Nominal Installation Dimensions and Clearances

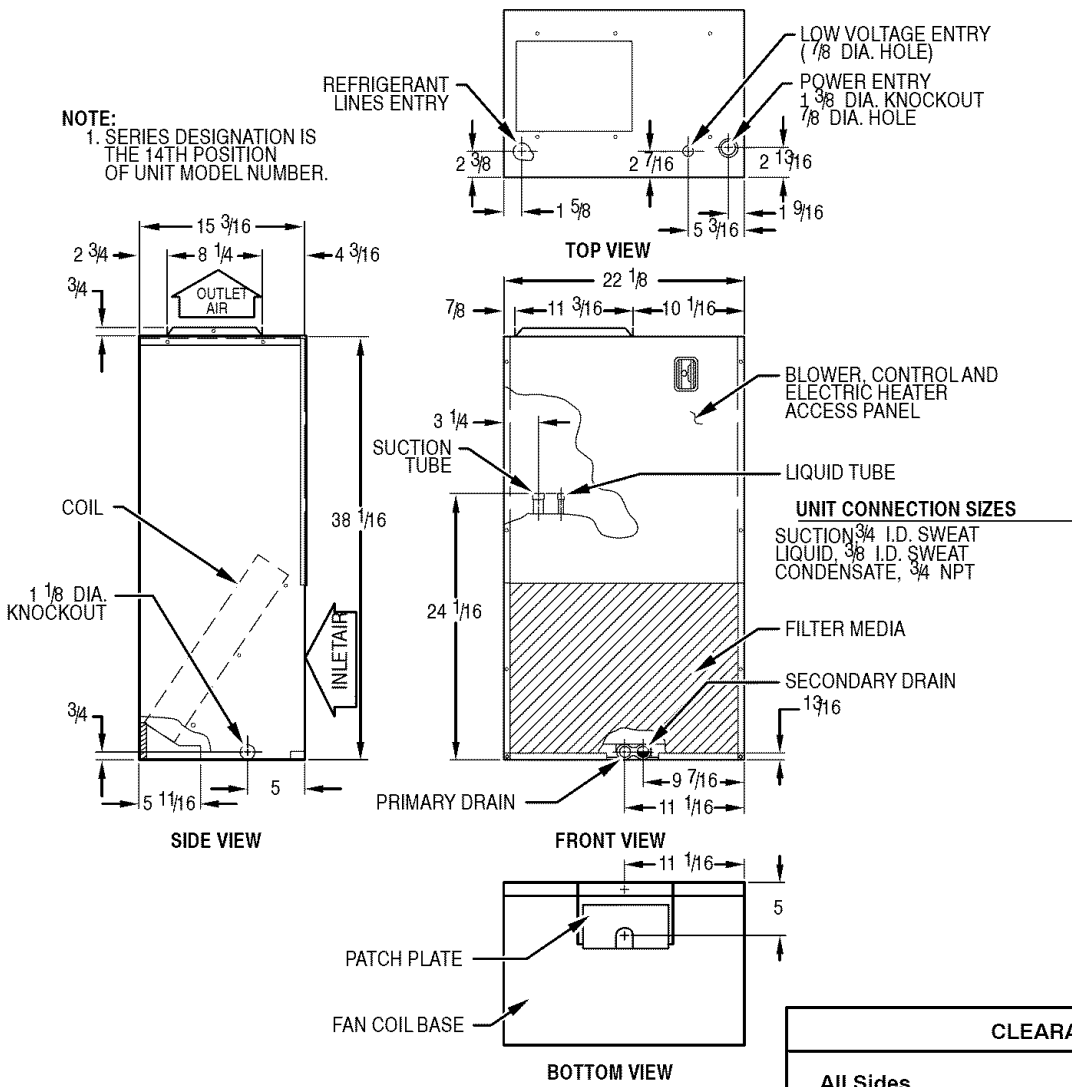

CLEARANCES	
All Sides	0"
From Supply Duct	0"
Recommended Service From Front	21"
(Service for blower, filter)	

General Information

⚠ WARNING

Installation or repairs made by unqualified persons can result in hazards to you and others. Installation MUST conform with local building codes and with the National Electrical Code NFPA70 current edition.

The information contained in this manual is intended for use by a qualified service technician familiar with safety procedures and equipped with the proper tools and test instruments.

Failure to carefully read and follow all instructions in this manual can result in equipment malfunction, property damage, personal injury and/or death.

The blower cabinet may be used for cooling or heat pump operation with or without electric heat. Installations without electric heat, require a Cooling Control Kit. The cabinet can be installed in an **Upflow position ONLY**.

Check Equipment

Unpack unit and move to final location. Remove carton, taking care not to damage unit. Inspect equipment for damage prior to installation. File claim with shipping company if shipment is damaged or incomplete. Locate rating plate on unit. It contains information needed to properly install unit. Check rating plate to be sure unit matches job specifications.

Location

Select the best position which suits the installation site conditions. The location should provide adequate structural support, space in the front of the unit for service access, clearance for return air and supply duct connections, space for refrigerant piping connections and condensate drain line connections.

See Clearances in Figure 1.

A front access panel is provided, which permits access to blower assembly and electrical controls for removal and servicing.

NOTE: Local codes may limit application of systems without a ducted return to single story dwellings.

Installation

The unit is designed for free-air return as enclosed in a closet with louvered door or for flush mounting in a wall. A factory-authorized louvered grille kit is available for flush mount application (AMWK001WG).

When unit is installed in a closet with a louvered door in return-air path, the free area of louvered opening in the door must be a minimum of 2.25 sq ft. Either align door opening with unit inlet or provide a 10-in. clearance between door and unit.

If unit is to be flush mounted in a wall, provide adequate support underneath base of unit. To assure proper condensate drainage, be sure unit is level.

Hanging Cabinet

Cabinet may be hung from the wall using accessory brackets (AMWK001MK). Use 1 X 4 or 2 X 4 support and a spacer for the bottom across studs to support the unit. Bottom spacer should be located above the bottom of the unit so it holds the unit out from the wall in a vertical position. **See Figure 2.**

CAUTION

Both wall support and spacer must be the same thickness or the unit will not hang correctly and Condensate Water will not drain correctly. Unit must be vertical or tilted slightly forward which the support bracket will do.

Duct Connections

Supply Duct

Connect supply-air duct over 3/4-in. flange provided on supply-air opening. Secure duct to flange using applicable fasteners for type of duct used, and seal duct-to-unit joint.

NOTE: Short duct runs tend to increase noise level.

When fan coil is equipped with an electric heater, install air ducts in accordance with standards 90A and 90B of National Fire Protection Association (NFPA). Use of flexible connectors between ductwork and unit will prevent transmission of vibration.

When electric heater is installed, use heat-resistant material for a flexible connector between ductwork and unit air discharge connection.

Ductwork passing through unconditioned space must be insulated and covered with a vapor barrier.

NOTE: Unit is intended for nonducted return-air applications. Local codes may limit this unit to single-level applications.

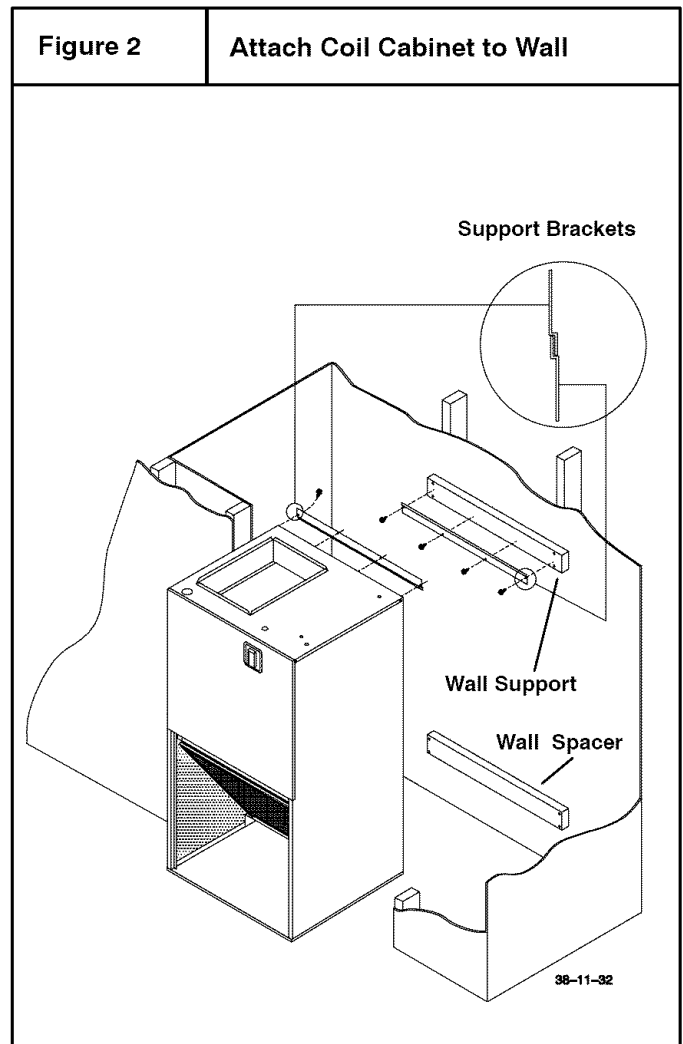

Condensate Drain

Condensate pan has primary and secondary drain connections to meet FHA requirements. (See Fig. 3.) These connections have 3/4-in. female pipe threads.

Tubing for all condensate drains should be a minimum of 7/8-in. OD. Drain lines from condensate pan to exterior of unit must be plastic pipe. Drain should be pitched downward at a slope of 1 in. per 10 ft.

If coil is located in or above a living space where damage may result from condensate overflow, a separate 3/4-in. drain must be provided from secondary drain connection. Run this drain to a place in compliance with local installation codes where it will be noticed when unit is operational.

Condensate flowing from secondary drain indicates a plugged primary drain.

Install a 3-in. trap in condensate drain line as close to coil as possible. Make sure that the top of trap is below connection to drain pan to prevent condensate from overflowing drain pan. Prime trap with water. Insulate drain if located above a living area and test condensate line for leaks.

Consult local codes for additional restrictions or precautions.

Orifice Sizing & Refrigerant Lines

NOTE: Do not remove seals from coil until tubing connections are ready to be made. See instructions packaged with outdoor unit for connecting refrigerant tubes.

Before connecting refrigerant tubing, be sure factory-supplied indoor refrigerant flow-control device is correct for outdoor unit size used. Refer to outdoor unit installation instructions.

When changing piston, use a backup wrench and do not over tighten. Maximum torque should not exceed 30 ft-lb. (See Fig. 3.)

Move unit into place and install refrigerant tubing as follows:

1. Route tubing to connection points.
2. Remove plugs from liquid and suction tubes.
3. Clean and braze tubing into place.
4. Pressurize system and leak-test. Repeat procedure until leak-free.

CAUTION

Do not vent refrigerant to atmosphere. Recover during system repair or final unit disposal.

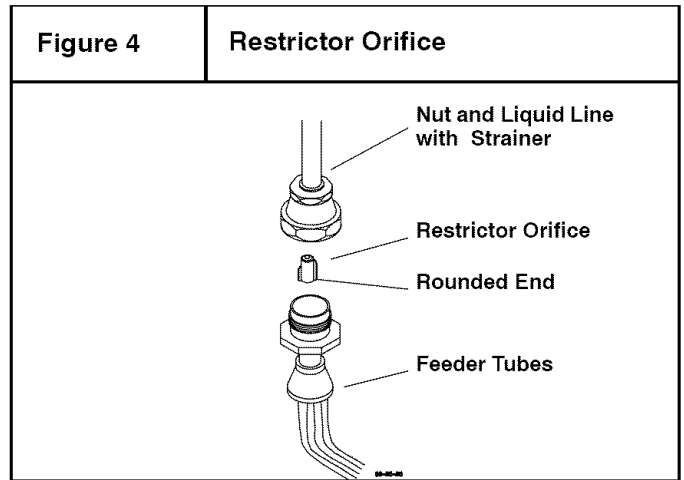
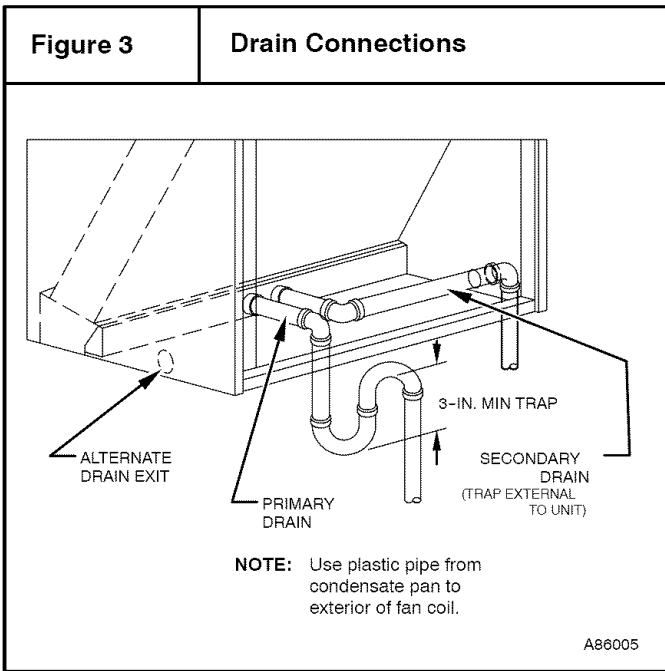

Field Installation of Controls

Units shipped from factory without heaters require a field-installed cooling control kit or heater. These kits are completely assembled and factory-wired for easy installation.

See Installation Instructions packaged with heaters for installation procedures. These unit Installation Instructions are to be used in conjunction with instructions packaged with heater. When installing accessory heat, optional cooling control kit is not required.

INSTALL COOLING CONTROL PACKAGE

1. Remove blower access panel (See Fig. 5.)
2. Install cooling control panel above blower motor on blower side plate. Attach with provided screws. (See Fig. 5.)
3. Route thermostat leads through small knockout in top of unit. Use grommet provided with cooling control to protect leads where they pass through casing.
4. Make low-voltage splice connections in low-voltage control box.
5. Route blower motor power leads up through hole in bottom of cooling control. Connect yellow common wire to piggyback common terminal on transformer. Connect black (HI) or red (LOW) speed tap wire to control board relay common terminal. See wiring label for proper speed tap selection.
6. Route unit power supply through knockout in top of unit and connect to line side of disconnect. Connect ground wire to ground lug. See wiring label to make connections.
7. Remove disconnect pullout.
8. Replace access panel.

ELECTRICAL CONNECTIONS

⚠ WARNING

Electrical shock hazard.

Before installing or servicing fan coil, always turn off all power to unit. There may be more than 1 disconnect switch. Turn off accessory heater power if applicable.

Field wires on side of disconnect found in fan coil remain live, even when pull-out is removed. Service and maintenance to incoming wiring can not be performed until main disconnect switch (remote to the unit) is turned off.

Failure to do so can result in property damage, personal injury and/or death.

NOTE: Before proceeding with electrical connections, make certain that voltage, frequency, and phase correspond to that specified on rating plate. Also, check to be sure that the service provided by utility is sufficient to handle additional load imposed by this equipment. Refer to unit wiring label for proper field high- and low-voltage wiring. Make all electrical connections in accordance with

9. Insert disconnect pullout through hole in access panel.

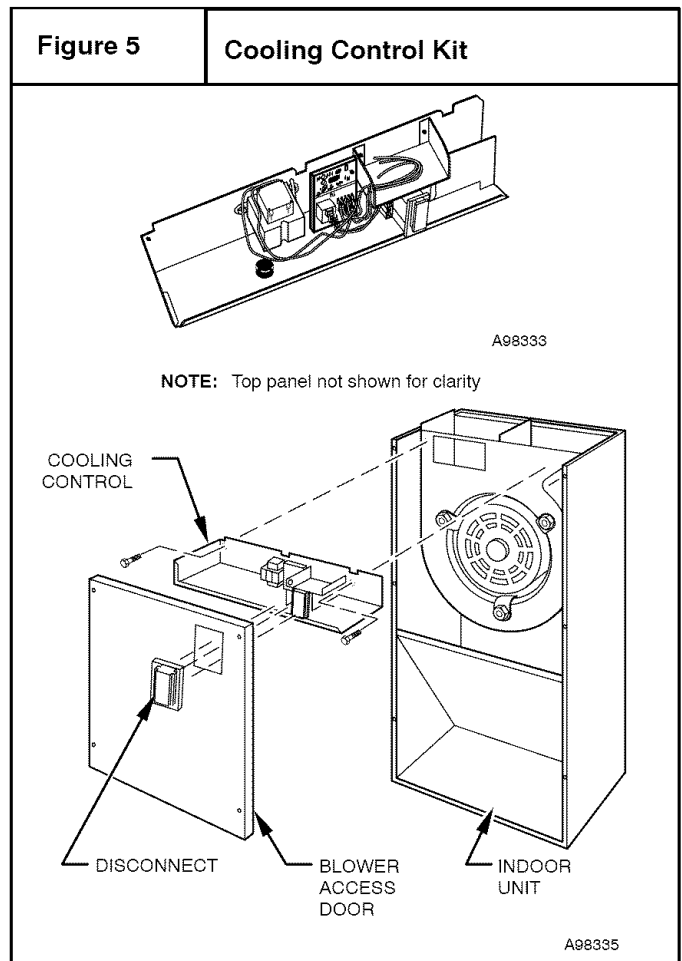

NEC and any local codes or ordinances that might apply. Unit must have a separate branch electrical circuit. The Cooling Control Kit and the heater packages provide a disconnect switch located within sight and readily accessible to the unit.

NOTE: All control kits are shipped from factory wired for 230-v transformer operation. For 208-v operation, move black primary lead from 230-v terminal to 208-v terminal.

See Fig. 6 and 7 for field low-voltage wiring. See Fig. 1 for location of the electrical inlets. For maximum ampacity and over-current protection, see unit rating plate.

1. Provide power supply for unit being installed in accordance with unit wiring diagram and rating plate.
2. Connect line-voltage leads to field lugs. Use copper wire only.
3. Use UL listed conduit and conduit connector for connecting line-voltage leads to unit and obtaining proper ground. Grounding can also be accomplished by using the ground lug provided in the control box.
4. Install rubber grommet packed with unit in hole for low-voltage wires.

5. Connect low-voltage leads to thermostat and outdoor unit. See Fig. 5 and 6 and the outdoor unit wiring label.

Use No. 18 AWG color-coded, insulated (35°C minimum) wire to make low-voltage connections between thermostat and unit. If thermostat is located more than 100 ft from unit as measured along low-voltage wire, use No. 16 AWG color-coded, insulated (35°C minimum) wire. All control kits from the factory utilize a printed-circuit board (PCB) which has a low voltage circuit protective fuse (5 amp), fan motor speed tap selection terminal (SPT), and time delay relay (TDR) jumper. To disable the TDR feature, sever the jumper wire JW1.

⚠ WARNING

Electrical shock hazard.

Unit cabinet must have a continuous electrical path to ground in order to minimize potential for personal injury or death if an electrical fault should occur. This ground may consist of electrical wire or approved conduit when installed in accordance with existing codes.

Failure to do so can result in property damage, personal injury and/or death.

See Figure 8 for Cooling Control and heater package part numbers, wire size, overcurrent protection sizes. All field-installed cooling control kits and heater packages are factory wired for 230-v transformer operation. When 208-v transformer operation is desired, move the black primary lead from the 230-v terminal to the 208-v terminal.

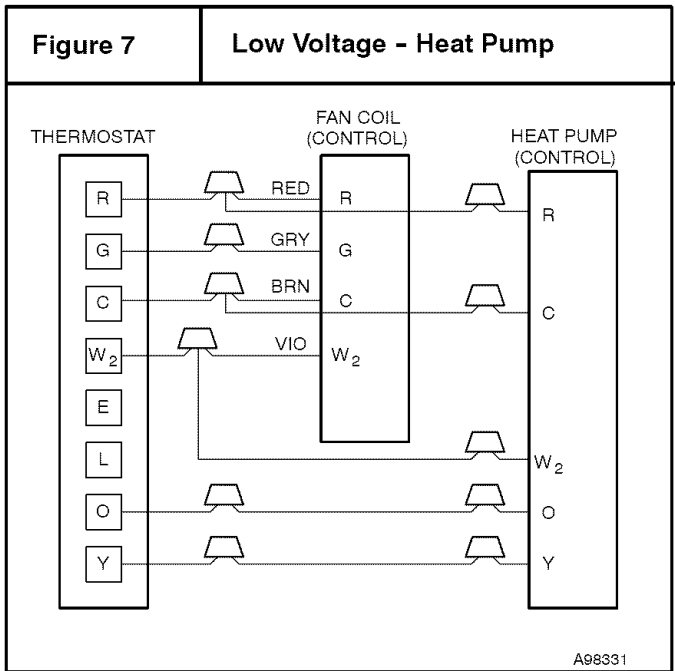

SELECT PROPER BLOWER SPEED

Before operating unit, be sure that proper blower speed has been selected. High speed tap is recommended for most applications. For those applications requiring lower air flows, low speed tap can be used.

Color Code For Motor Lead Wires

MOTOR SPEED TAP	WIRE COLOR
C - Common	Yellow
1 - High	Black
2 - Low	Red

NOTE: Fan speeds are selected manually. To change the fan speed, interchange the black and red fan motor leads on printed circuit board terminal SPT (COM). START-UP Refer to outdoor unit Installation Instructions for system start-up instructions and refrigerant charging method details.

CARE AND MAINTENANCE

For continuing high performance and to minimize possible equipment failure, it is essential that periodic maintenance be performed on this equipment. Consult your local dealer as to proper frequency of maintenance and availability of a maintenance contract. The ability to properly perform maintenance on this equipment requires certain mechanical skills and tools. If you do not possess these, contact your dealer for maintenance. The only consumer service recommended or required is filter maintenance.

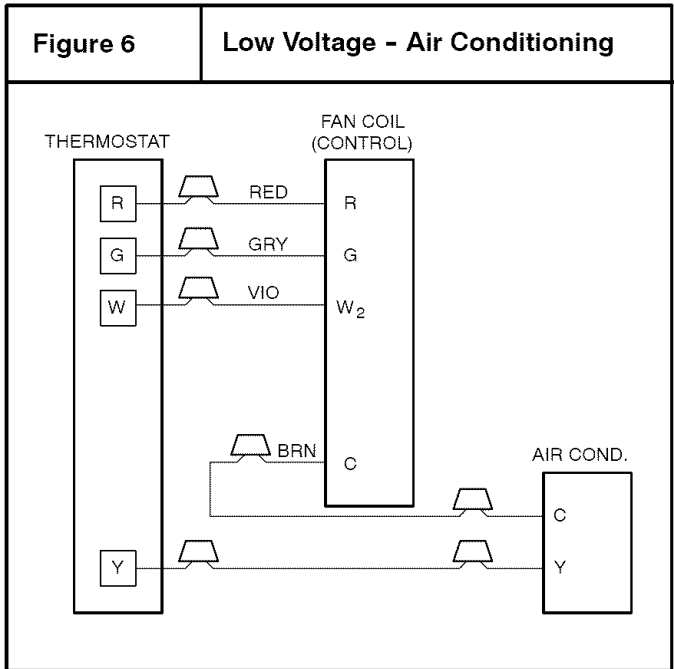
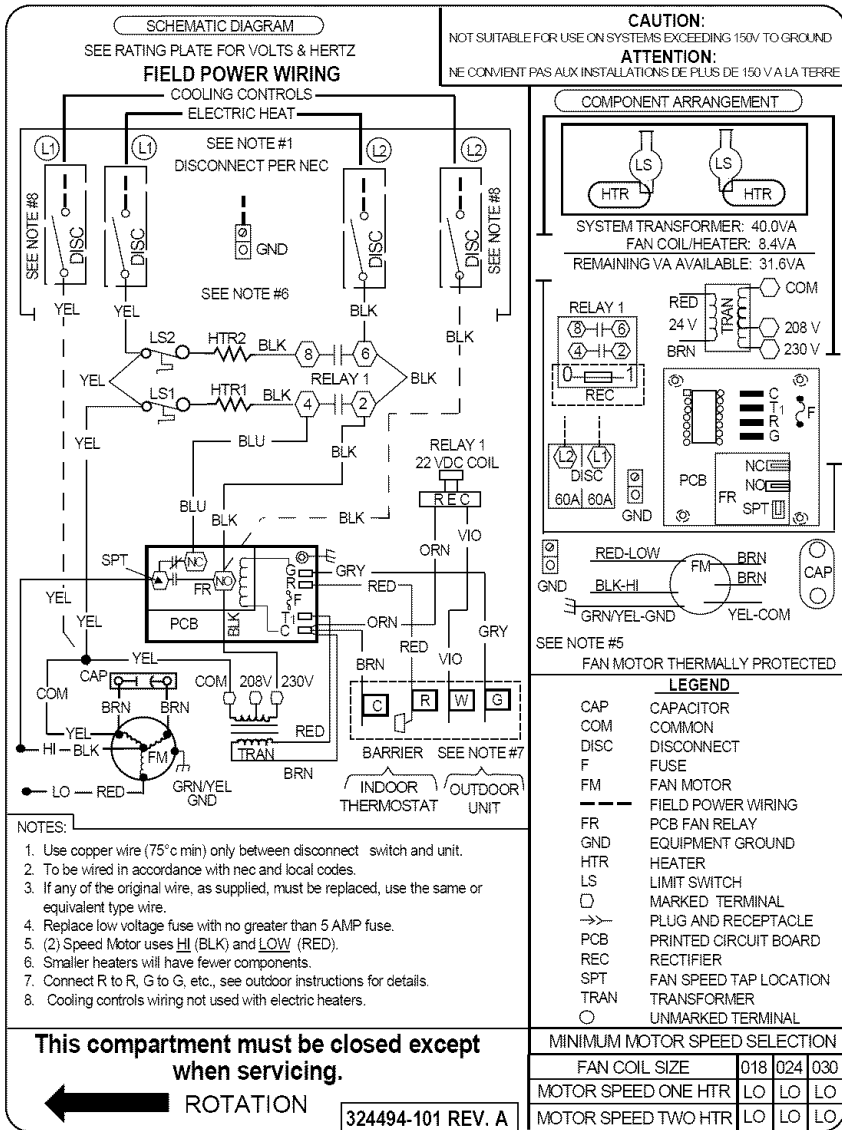

Figure 8

Electrical Data

PART NO.	UNIT SIZE	VOLTAGE	NOM KW @ 240-V	HEATER AMPS	HEATER CAPACITY (BTUH)	WIRE RATING (°C)	MIN WIRE SIZE*	MIN AMPACITY	MAX CIRCUIT PROTECTION
AMWK001CK	018	208/230	0	0.0/0.0	0/0	75	14	2.5	15/15
	024								
	030								
AMWK005AH	018	208/230	5.0	18.1/20.0	12799/15700	75	10/10	25.2/27.5	30/30
	024								
	030								
AMWK007AH	018	208/230	7.5	27.1/30.0	19215/23515	75	8/8	36.4/40.0	40/40
	024								
	030								
AMWK011AH	018	208/230	11.0	39.8/44.0	25597/31331	75	6/6	52.3/57.5	60/60
	024								
	030								



Replacement Parts

KEY NO.	DESCRIPTION	PART NUMBER																		
			FWM1800A1	FWM1805A1	FWM1807A1	FWM1811A1	FWM2400A1	FWM2405A1	FWM2407A1	FWM2411A1	FWM3000A1	FWM3005A1	FWM3007A1	FWM3011A1						
1	Blower Asy	1170633	1	1	1	1														
1	Blower Asy	1170634	-	-	-	-	1	1	1	1										
1	Blower Asy	1170635	-	-	-	-	-	-	-	-	1	1	1	1						
2	Motor, Blower	1170644	1	1	1	1														
2	Motor, Blower	1170645	-	-	-	-	1	1	1	1										
2	Motor, Blower	1170646	-	-	-	-	-	-	-	-	1	1	1	1						
3	Capacitor	1170647	1	1	1	1	1	1	1	1										
3	Capacitor	1170648	-	-	-	-	-	-	-	-	1	1	1	1						
4	Wheel, Blower	1170652	1	1	1	1	1	1	1	1	1	1	1	1						
5	Coil, Evaporator	1170681	1	1	1	1														
5	Coil, Evaporator	1170682	-	-	-	-	1	1	1	1										
5	Coil, Evaporator	1170683	-	-	-	-	-	-	-	-	1	1	1	1						
6	Distributor Asy	1170653	1	1	1	1														
6	Distributor Asy	1170654	-	-	-	-	1	1	1	1										
6	Distributor Asy	1170655	-	-	-	-	-	-	-	-	1	1	1	1						
7	Restrictor, .049	1087678	1	1	1	1														
7	Restrictor, .060	1087679	-	-	-	-	1	1	1	1										
7	Restrictor, .066	1062387	-	-	-	-	-	-	-	-	1	1	1	1						
8	Adaptor, Flow Control RH	1084878	1	1	1	1	1	1	1	1	1	1	1	1						
9	Pan, Condensate Asy	1170656	1	1	1	1	1	1	1	1	1	1	1	1						
10	Pan, Condensate	1170657	1	1	1	1	1	1	1	1	1	1	1	1						
11	Element Asy 5 KW	1170668	-	1							1									
11	Element Asy 7.5 KW	1170669	-	1							1									
11	Element Asy 11 KW	1170670	-	-	1						1									
12	Board, Circuit w/Relay	1170671	-	1	1	1					1	1	1	1						
13	Board, Rectifier	1170672	-	1	1	1					1	1	1	1						
14	Switch, Limit	1170673	-	1	2	2					1	2	2	1						
15	Relay	1170674	-	1	1	1					1	1	1	1						
16	Disconnect, Non-Fused	1170675	-	1	1	1					1	1	1	1						
17	Transformer	1170676	-	1	1	1					1	1	1	1						
18	Lug, Ground	1170677	-	1	1	1					1	1	1	1						

KEY NO.	DESCRIPTION	PART NUMBER																		
			FWM1800A1	FWM1805A1	FWM1807A1	FWM1811A1	FWM2400A1	FWM2405A1	FWM2407A1	FWM2411A1	FWM3000A1	FWM3005A1	FWM3007A1	FWM3011A1						
A	Panel, Top	1170627	1	1	1	1	1	1	1	1	1	1	1	1	1	1	1	1	1	1
B	Bracket, Filter	1170628	1	1	1	1	1	1	1	1	1	1	1	1	1	1	1	1	1	1
C	Support, Coil	1170629	1	1	1	1	1	1	1	1	1	1	1	1	1	1	1	1	1	1
D	Base, Fan Coil	1170630	1	1	1	1	1	1	1	1	1	1	1	1	1	1	1	1	1	1
E	Plate	1170680	1	1	1	1	1	1	1	1	1	1	1	1	1	1	1	1	1	1
F	Panel, Blower Door	1170631	1	1	1	1	1	1	1	1	1	1	1	1	1	1	1	1	1	1
G	Filter	1170632	1	1	1	1	1	1	1	1	1	1	1	1	1	1	1	1	1	1
H	Screw	1170636	3	3	3	3	3	3	3	3	3	3	3	3	3	3	3	3	3	3
J	Panel, Blower Cutoff	1170637	1	1	1	1	1	1	1	1	1	1	1	1	1	1	1	1	1	1
K	Housing, Blower	1170638	1	1	1	1	1	1	1	1	1	1	1	1	1	1	1	1	1	1
L	Wrapper, Blower	1170639	1	1	1	1	1	1	1	1	1	1	1	1	1	1	1	1	1	1
M	Plate, Blower Side	1170640	1	1	1	1	1	1	1	1	1	1	1	1	1	1	1	1	1	1
N	Plate, Blower Side (Motor Side)	1170641	1	1	1	1	1	1	1	1	1	1	1	1	1	1	1	1	1	1
P	Ring, Inlet	1170642	1	1	1	1	1	1	1	1	1	1	1	1	1	1	1	1	1	1
Q	Strap, Capacitor	1170643	1	1	1	1	1	1	1	1	1	1	1	1	1	1	1	1	1	1
R	Arm, Motor Mount	1170649	3	3	3	3	3	3	3	3	3	3	3	3	3	3	3	3	3	3
S	Band, Motor Mount	1170650	1	1	1	1	1	1	1	1	1	1	1	1	1	1	1	1	1	1
T	Grommet, Motor Mount	1170651	3	3	3	3	3	3	3	3	3	3	3	3	3	3	3	3	3	3
U	Pan, Condensate Shield	1170658	1	1	1	1	1	1	1	1	1	1	1	1	1	1	1	1	1	1
V	Panel, Control	1170659	-	1							1									
V	Panel, Control	1170660	-	-	1	1					1	1								
W	Bracket, Disc.Mtg.	1170661	-	1	1	1					1	1	1							
X	Panel, Protective	1170662	-	1	1	1					1	1	1							
Y	Barrier	1170663	-	1	1	1					1	1	1							
Y	Harness Asy	1170664	-	1	1	1					1	1	1							
Y	Harness Asy	1170665	-	-	1	1					1	1								
Y	Harness Asy	1170666	-	1	1	1					1	1	1							
Y	Harness Asy	1170667	-	1	1	1					1	1	1							

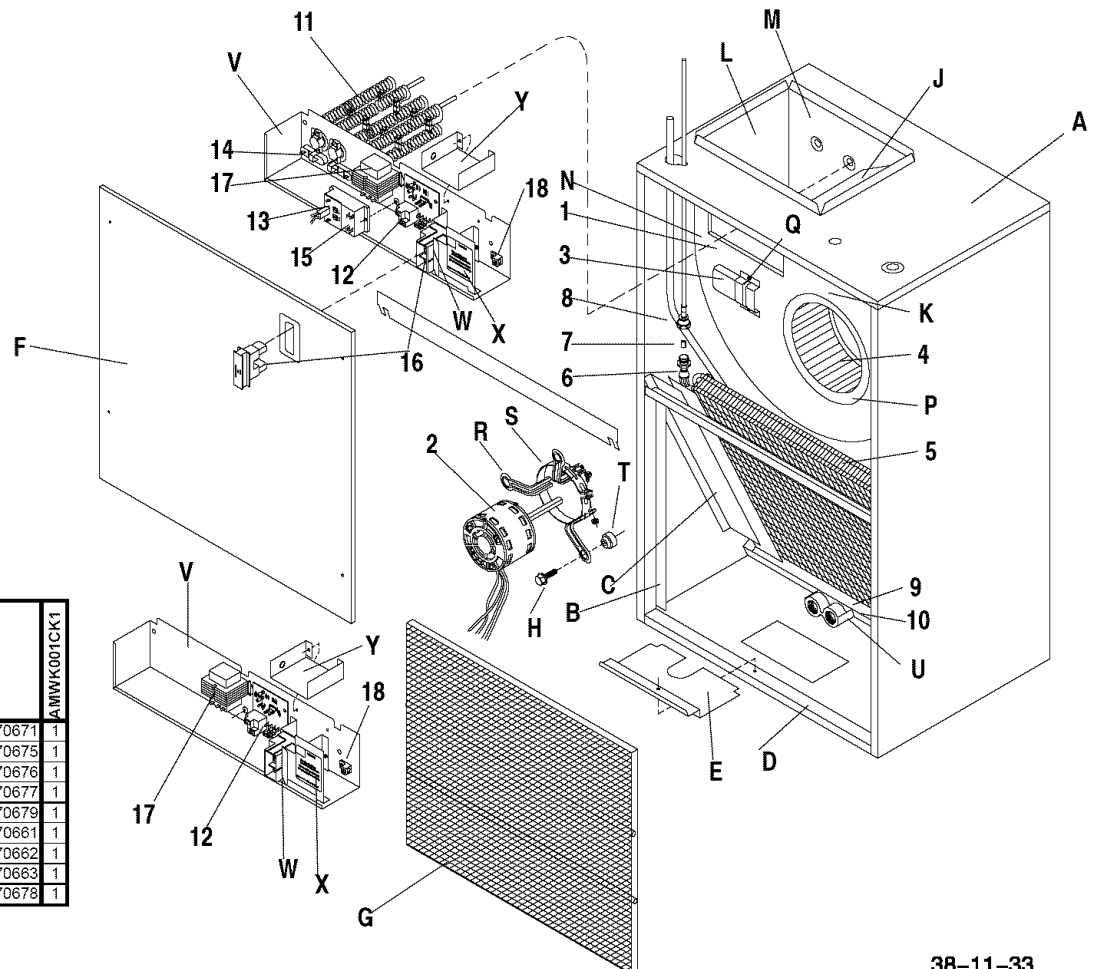

KEY NO.	DESCRIPTION	PART NUMBER	QTY
	Cooling Control Kit (Option)		
12	Board, Circuit w/Relay	1170671	1
16	Disconnect, Non-Fused	1170675	1
17	Transformer	1170676	1
18	Lug, Ground	1170677	1
V	Panel, Control	1170679	1
W	Bracket, Disc.Mtg.	1170661	1
X	Panel, Protective	1170662	1
Y	Barrier	1170663	1
Y	Harness Asy	1170678	1