

Installation Instructions

90+ 2-Stage & Variable Speed Category IV Furnace

*9MPT & *9MPV

* Denotes Brands (C, H, T)

FAN ASSISTED, DIRECT VENT GAS FURNACE

SAFETY REQUIREMENTS

Recognize safety information. This is the safety-alert symbol . When you see this symbol on the furnace and in instructions manuals be alert to the potential for personal injury.

Understand the signal words *DANGER*, *WARNING*, or *CAUTION*. These words are used with the safety-alert symbol. *DANGER* identifies the most serious hazards, those that **will** result in severe personal injury or death. *WARNING* signifies a hazard that **could** result in personal injury or death. *CAUTION* is used to identify unsafe practices that **may** result in minor personal injury or product and property damage. *NOTE* is used to highlight suggestions that will result in enhanced installation, reliability, or operation.

Installing and servicing heating equipment can be hazardous due to gas and electrical components. Only trained and qualified personnel should install, repair, or service heating equipment.

Untrained service personnel can perform basic maintenance functions such as cleaning and replacing air filters. All other operations must be performed by trained service personnel. When working on heating equipment, observe precautions in the literature, on tags, and on labels attached to or shipped with the unit and other safety precautions that may apply.

Follow all safety codes. In the United States, follow all safety codes including the current edition National Fuel Gas Code (NFPA) ANSI Z223.1-2002/NFPA No. 54-2002. In Canada, refer to the current edition of the National Standard of Canada Natural Gas and Propane Installation Code (NSCNGPIC) CSA B149.1-00. Wear safety glasses and work gloves. Have fire extinguisher available during start-up and adjustment procedures and service calls.

These instructions cover minimum requirements and conform to existing national standards and safety codes. In some instances, these instructions exceed certain local codes and ordinances, especially those that may not have kept up with changing residential construction practices. We require these instructions as a minimum for a safe installation.

International Comfort Products, LLC
Lewisburg, TN 37091



INSTALLER: Affix these instructions on or adjacent to the furnace.

CONSUMER: Retain these instructions for future reference.

Table of Contents

1. Safe Installation Requirements	3	7. Ductwork and Filter	33
2. Installation	4	8. Checks and Adjustments	36
3. Combustion & Ventilation Air	7	9. Furnace Maintenance	38
4. Vent & Combustion Air Piping	10	10. Sequence of Operation & Diagnostics	39
5. Gas Supply and Piping	28	11. Concentric Vent Termination	44
6. Electrical Wiring	31	Tech Support and Parts	47



WARNING

ELECTRIC SHOCK HAZARD
Failure to follow safety warnings exactly could result in serious injury, death, and/or property damage.
Turn Off All Power Before Servicing.

WARNING

CARBON MONOXIDE POISONING AND FIRE HAZARD.
Failure to follow safety warnings exactly could result in serious injury, death, and/or property damage.
This furnace is not designed for use in mobile homes, trailers or recreational vehicles.

START-UP CHECK SHEET

For 90+ Furnace

(Keep this page for future reference)

Dealer Name: _____

Address: _____

City, State(Province), Zip or Postal Code: _____

Phone: _____

Owner Name: _____

Address: _____

City, State(Province), Zip or Postal Code: _____

Model Number: _____

Serial Number: _____

Type of Gas: Natural: LP:

Which blower speed tap is used?

High Fire _____ Low Fire _____ or (Cooling) _____

Temperature of Supply Air: High Fire (°F) _____ or (°C) _____

Low Fire (°F) _____ or (°C) _____

Temperature of Return Air: (°F) _____ or (°C) _____

Temp. Rise Hi Fire (Supply - Return): (°F) _____ or (°C) _____

Lo Fire (Supply - Return): (°F) _____ or (°C) _____

Filter Type and Size: _____

Fan "Time ON" Setting: _____

Fan "Time OFF" Setting: _____

Dealer Comments: _____

Business Card Here

Manual Gas Shut-Off Upstream

of Furnace/Drip-Leg? YES NO

Condensate Drain Connected? YES NO

Condensate Drain Trapped? YES NO

Transition Pressure switch hose relocated for U/D/H

Application? YES NO

Blower Speed Checked? YES NO

All Electrical Connections Tight? YES NO

Gas Valve OK? YES NO

Measured Line Pressure When Firing Unit: _____

Calculated Firing Rate:(See *Checks and Adjustments* Section). (Lo) _____ & (Hi) _____

Temperature Rise (supply-return temperature):(°F) _____

Measured Manifold Gas Pressure: (Lo) _____ & (Hi) _____

Static Pressure (Ducts): Supply Air _____ Return _____

Date of Start-Up: _____

CO ? _____

CO2 ? _____

1. Safe Installation Requirements



WARNING

FIRE, EXPLOSION, AND ASPHIXIATION HAZARD

Improper adjustment, alteration, service, maintenance or installation could cause serious injury, death and/or property damage.

Installation or repairs made by unqualified persons could result in hazards to you and others. Installation **MUST** conform with local codes or, in the absence of local codes, with codes of all governmental authorities having jurisdiction.

The information contained in this manual is intended for use by a qualified service agency that is experienced in such work, is familiar with all precautions and safety procedures required in such work, and is equipped with the proper tools and test instruments.

NOTE: This furnace is design-certified by the CSA International (formerly AGA and CGA) for installation in the United States and Canada. Refer to the appropriate codes, along with this manual, for proper installation.

- Use only the Type of gas approved for this furnace (see **Rating Plate** on unit). Overfiring will result in failure of heat exchanger and cause dangerous operation. (Furnaces can be converted to L.P. gas with approved kit.)
- Install this furnace only in a location and position as specified in "2. *Installation*" of these instructions.
- Provide adequate combustion and ventilation air to the furnace as specified in "4. *Combustion and Ventilation Air*" of these instructions.
- Combustion products must be discharged outdoors. Connect this furnace to an approved vent system only, as specified in "5. *Combustion and Ventilation Air*, 6. *Horizontal Venting* and 7. *Masonry Chimney Venting*" of these instructions.
- Never test for gas leaks with an open flame. Use a commercially available soap solution made specifically for the detection of leaks to check all connections, as specified in "8. *Gas Supply and Piping, Final Check*" of these instructions.
- Always install furnace to operate within the furnace's intended temperature-rise range with a duct system which has an external static pressure within the allowable range, as specified in "*Technical Support Manual*" of these instructions.
- When a furnace is installed so that supply ducts carry air circulated by the furnace to areas outside the space containing the furnace, the return air shall also be handled by a duct(s) sealed to the furnace casing and terminating outside the space containing the furnace.
- A gas-fired furnace for installation in a residential garage must be installed as specified in "2. *Installation Requirements*" of these instructions.

- This furnace is not to be used for temporary heating of buildings or structures under construction.
- This furnace is **NOT** approved for installation in mobile homes, trailers or recreation vehicles.
- Seal around supply and return air ducts.
- Install correct filter type and size.
- Unit **MUST** be installed so electrical components are protected from direct contact with water.

Safety Rules

Your unit is built to provide many years of safe and dependable service providing it is properly installed and maintained. However, abuse and/or improper use can shorten the life of the unit and create hazards for you, the owner.

- A. The U.S. Consumer Product Safety Commission encourages installation of carbon monoxide alarms. There can be various sources of carbon monoxide in a building or dwelling. The sources could be gas-fired clothes dryers, gas cooking stoves, water heaters, furnaces, gas-fired fireplaces, wood fireplaces, and several other items.

Carbon monoxide can cause serious bodily injury and/or death. Carbon monoxide or "CO" is a colorless and odorless gas produced when fuel is not burned completely or when the flame does not receive sufficient oxygen.

Therefore, to help alert people of potentially dangerous carbon monoxide levels, you should have a commercially available carbon monoxide alarm that is listed by a nationally recognized testing agency in accordance with Underwriters Laboratories Inc. Standard for Single and Multiple Station Carbon Monoxide Alarms, ANSI/UL 2034 or the CSA 6.19-01 Residential Carbon Alarming Devices installed and maintained in the building or dwelling concurrently with the gas-fired furnace installation (see Note below). The alarm should be installed as recommended by the alarm manufacturer's installation instructions.

- B. There can be numerous sources of fire or smoke in a building or dwelling. Fire or smoke can cause serious bodily injury, death, and/or property damage. Therefore, in order to alert people of potentially dangerous fire or smoke, you should have fire extinguisher and smoke alarms listed by Underwriters Laboratories installed and maintained in the building or dwelling (see Note below).

Note: The manufacturer of your furnace does not test any alarms and makes no representations regarding any brand or type of alarms.

- C. To ensure safe and efficient operation of your unit, you should do the following:
1. **Thoroughly read this manual and labels on the unit.** This will help you understand how your unit operates and the hazards involved with gas and electricity.
 2. **Do not use this unit if any part has been under water.** Immediately call a qualified service technician to inspect the unit and to replace any part of the control system and any gas control which has been under water.
 3. **Never obstruct the vent grilles, or any ducts that provide air to the unit.** Air must be provided for proper combustion and ventilation of flue gases.

Frozen Water Pipe Hazard

WARNING

WATER DAMAGE TO PROPERTY HAZARD

Failure to protect against the risk of freezing could result in property damage and/or personal injury.

Do not leave your home unattended for long periods during freezing weather without turning off water supply and draining water pipes or otherwise protecting against the risk of frozen pipes and resultant damage.

Your furnace is designed solely to provide a safe and comfortable living environment. The furnace is NOT designed to ensure that water pipes will not freeze. It is equipped with several safety devices that are designed to turn the furnace off and prevent it from restarting in the event of various potentially unsafe conditions.

If your furnace remains off for an extended time, the pipes in your home could freeze and burst, resulting in serious water damage.

If the structure will be unattended during cold weather you should take these precautions.

1. Turn off the water supply to the structure and drain the water lines if possible and add an antifreeze for potable water to drain traps and toilet tanks. Open faucets in appropriate areas.

-or-

2. Have someone check the structure frequently during cold weather to make sure it is warm enough to prevent pipes from freezing. Instruct them on a service agency to call to provide service, if required.

-or-

3. Install a reliable remote sensing device that will notify somebody of freezing conditions within the home.

Winter Shutdown

If you go away during the winter months and do not leave the heat on in your home, the plastic transition box and the condensate trap on the furnace must be protected from freeze damage. (See Figure 9 through Figure 18)

1. Disconnect the $\frac{5}{8}$ " OD rubber hose from the vent drain fitting that is located downstream of the combustion blower. Insert a funnel into the hose and pour four(4) ounces of sanitary type (RV) antifreeze into the condensate trap. Reconnect the $\frac{5}{8}$ " OD rubber hose to the stub on the vent drain fitting. Secure with the hose clamp.
2. Disconnect the $\frac{3}{4}$ " OD rubber hose from the condensate trap. Insert a funnel into the hose and pour four(4) ounces of sanitary type (RV) antifreeze into the plastic Transition box. Squeeze the hose together near the end and quickly reconnect the $\frac{3}{4}$ " OD rubber hose to the stub on the condensate trap. Secure with the hose clamp.

When you return home, your furnace will be ready to start, as it is not necessary to drain the antifreeze from the furnace.

2. Installation

WARNING

CARBON MONOXIDE POISONING HAZARD

Failure to properly vent this furnace or other appliances could result in death, personal injury and/or property damage.

This furnace can NOT be common vented or connected to any type B, BW or L vent or vent connector, nor to any portion of a factory-built or masonry chimney. If this furnace is replacing a previously common-vented furnace, it may be necessary to resize the existing vent and chimney to prevent oversizing problems for the other remaining appliance(s). See *Venting and Combustion Air Check* in the 5. *Combustion & Ventilation Air* section. This furnace MUST be vented to the outside.

Location and Clearances

1. Refer to Figure 1 or Figure 2 for typical installation and basic connecting parts required. Refer to Figure 4 for typical horizontal direct vent installation and basic connecting parts required. Supply and return air plenums and duct are also required.
2. If furnace is a replacement, it is usually best to install the furnace where the old one was. Choose the location or evaluate the existing location based upon the minimum clearance and furnace dimensions (Figure 3).

WARNING

FROZEN AND BURST WATER PIPE HAZARD

Failure to protect against the risk of freezing could result in property damage and/or personal injury.

Special precautions MUST be made if installing furnace in an area which may drop below freezing. This can cause improper operation or damage to equipment. If furnace environment has the potential of freezing, the drain trap and drainline must be protected. The use of electric heat tape or RV antifreeze is recommended for these installations. (See "*Condensate Trap Freeze Protection Section*")

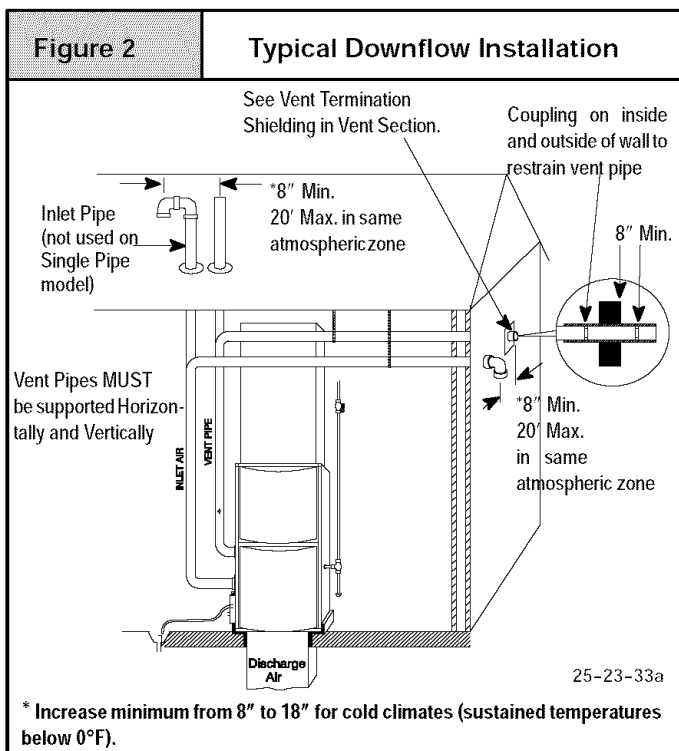
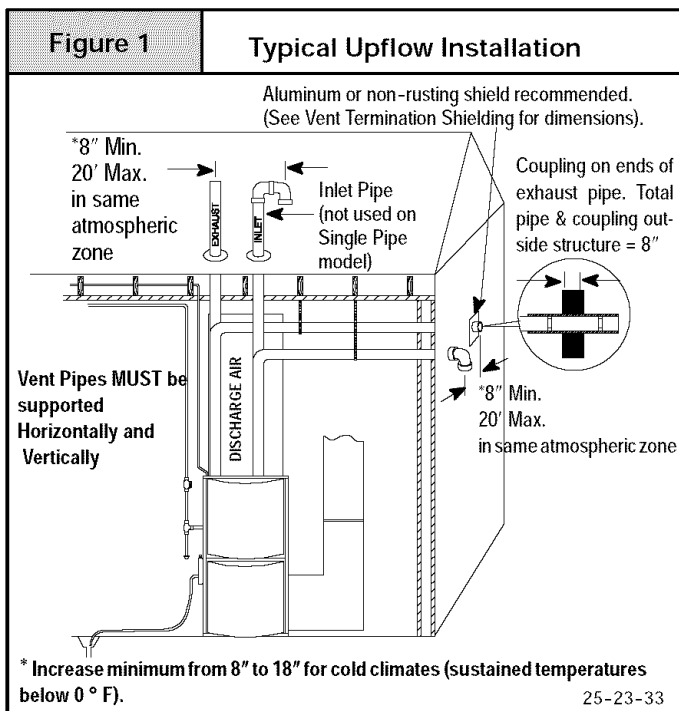

Installation Requirements

1. Install furnace level.
2. This furnace is **NOT** to be used for temporary heat of buildings or structures under construction.
3. Install furnace as centralized as practical with respect to the heat distribution system.
4. Install the vent pipes as short as practical. (See *Vent and Combustion Air Piping* section).
5. Maintain clearance for fire safety and servicing. A front clearance of 30" is required for access to the burner, controls and filter.
6. Use a raised base for upflow furnace if the floor is damp or wet at times.
7. For downflow installations, non combustible subbase must be used under the furnace unless installation is on a non combustible floor surface. This requirement applies even when a coil box or cabinet is used.
8. For horizontal installations, line contact is permissible only between lines formed by intersection of back and two sides of furnace jacket, and building joists, studs or framing.
9. Residential garage installations require:
 - Burners and ignition sources installed at least 18" above the floor.
 - Located or physically protected from possible damage by a vehicle.
10. Local codes may require a drain pan under the entire furnace and condensate trap when the furnace is installed in attic application.

Installation Positions

This furnace can be installed in an upflow, horizontal (either left or right) or downflow airflow position. **DO NOT** install this furnace on its back. For the upflow position, the return air ductwork can be attached to either the left or right side panel and/or the bottom. For horizontal and downflow positions, the return air ductwork must be attached to the bottom. The return air ductwork must **never** be attached to the back of the furnace.

Furnace Installation Considerations

The installation of the furnace for a given application will dictate the position of the furnace, the airflow, ductwork connections, vent and combustion air piping. Consideration must be given to the following:

Condensate Trap and Drain Lines

The supplied condensate trap must be attached to the furnace side panel on either the left or right side. For horizontal installations, the drain trap is vertically attached to the side panel below the furnace. A minimum clearance of 6" below the furnace is required for the condensate trap. Downward slope of the condensate drain line from the condensate trap to the drain location must be provided. Adequate freeze protection of the drain trap and the drain line must be provided. See "*Condensate Drain Trap*" section for further details.

Leveling

Proper leveling of the furnace must be provided to insure proper drainage of the condensate from the furnace. The furnace must be level to within 1/4" from front to back and from side to side for upflow and downflow installations or top to bottom for horizontal installations.

Vent and Combustion Air Connections

On the Dual Certified furnace, the vent and combustion air pipes attach to the furnace through the top panel for the upflow and hori-

⚠ WARNING

CARBON MONOXIDE POISONING HAZARD.

Failure to follow safety warnings exactly could result in serious injury, death, or property damage.

Do **NOT** operate furnace in a corrosive atmosphere containing chlorine, fluorine or any other damaging chemicals, which could shorten furnace life.

Refer to 3. *Combustion & Ventilation Air* section, *Contaminated Combustion Air* for combustion air evaluation and remedy.

zontal installations. For the downflow installation, the vent and combustion air pipes attach to the furnace through the alternate locations on the furnace side panels.

Note: On the Direct Vent furnace, the vent pipe attaches to the furnace through the side panels. The combustion air pipe attaches to the top panel or to the alternate location on the side panel.
On the Single Pipe furnace, the vent pipe attaches to the furnace through the furnace side panels.

Note: Repositioning of the combustion blower is required for the vent pipe connection to the furnace through the "right side" panel. See "Vent and Combustion Air Piping" section for further details.

Figure 3 Dimensions and Clearances

MINIMUM CLEARANCES TO COMBUSTIBLE MATERIALS FOR ALL UNITS	
REAR	0
FRONT (combustion air openings in furnace and in structure)	3"
Required For Service	*24"
ALL SIDES OF SUPPLY PLENUM	1"
SIDES	0
VENT	0
TOP OF FURNACE	1"

*30" clearance recommended for casing removal.

Horizontal position: Line contact is permissible only between lines formed by intersections of top and two sides of furnace jacket, and building joists, studs or framing.

NOTE: Evaporator "A" coil drain pan dimensions may vary from furnace duct opening size. Always consult evaporator specifications for duct size requirements.

Furnace is designed for bottom return or side return.

Return air through back of furnace is NOT allowed.

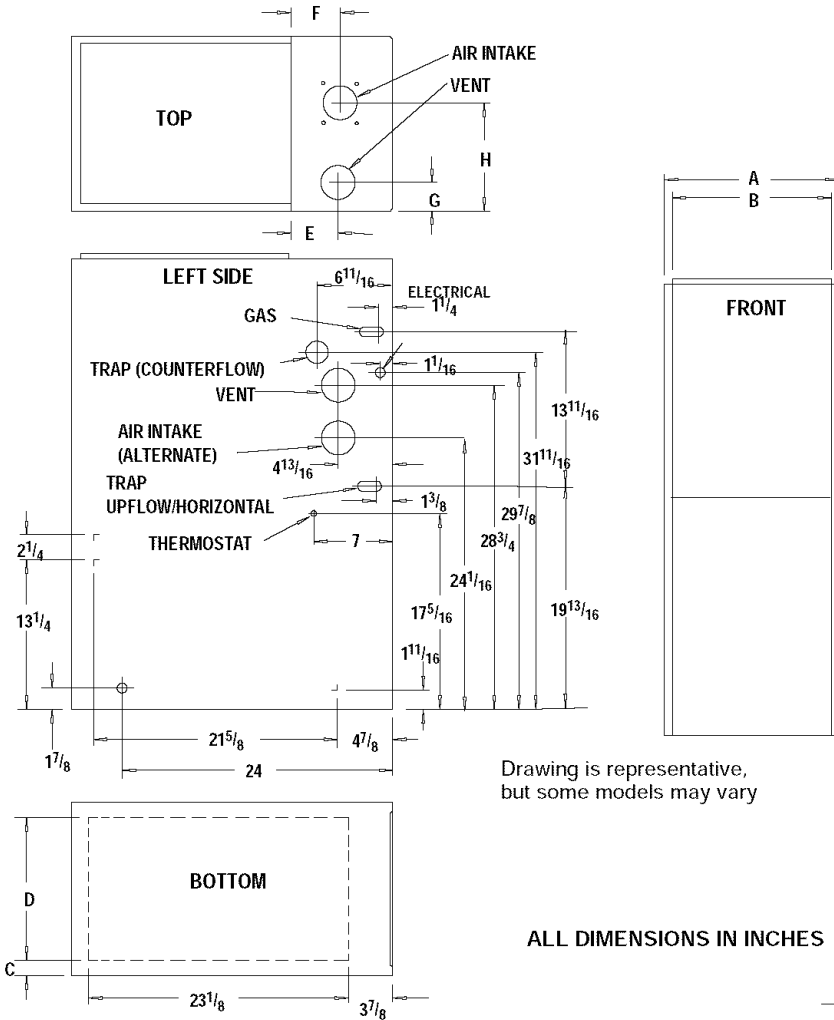

Drawing is representative, but some models may vary

ALL DIMENSIONS IN INCHES

Unit Capacity	Cabinet		Bottom		Top			
	A	B	C	D	E	F	G	H
*9MPT050F12A	19 ¹ / ₈	17 ⁵ / ₈	2 ¹ / ₈	14 ³ / ₄	4 ³ / ₈	4 ¹ / ₂	2 ¹ / ₂	9 ¹ / ₂
*9MPT075F14A	19 ¹ / ₈	17 ⁵ / ₈	2 ¹ / ₈	14 ³ / ₄	4 ³ / ₈	4 ¹ / ₂	2 ¹ / ₂	9 ¹ / ₂
*9MPT100J16A	22 ³ / ₄	21 ¹ / ₄	1 ¹⁵ / ₁₆	18 ³ / ₄	4 ³ / ₈	4 ¹ / ₂	2 ⁵ / ₈	11 ³ / ₈
*9MPT125L20A	24 ¹ / ₂	23	1 ¹ / ₁₆	23	4 ³ / ₈	4 ¹ / ₂	2 ¹ / ₄	12 ¹ / ₄
*9MPV050F12A	19 ¹ / ₈	17 ⁵ / ₈	2 ¹ / ₈	14 ³ / ₄	4 ³ / ₈	4 ¹ / ₂	2 ¹ / ₂	9 ¹ / ₂
*9MPV075F14A	19 ¹ / ₈	17 ⁵ / ₈	2 ¹ / ₈	14 ³ / ₄	4 ³ / ₈	4 ¹ / ₂	2 ¹ / ₂	9 ¹ / ₂
*9MPV100J20A	22 ³ / ₄	21 ¹ / ₄	1 ¹⁵ / ₁₆	18 ³ / ₄	4 ³ / ₈	4 ¹ / ₂	2 ⁵ / ₈	11 ³ / ₈
*9MPV125L20A	24 ¹ / ₂	23	1 ¹ / ₁₆	23	4 ³ / ₈	4 ¹ / ₂	2 ¹ / ₄	12 ¹ / ₄

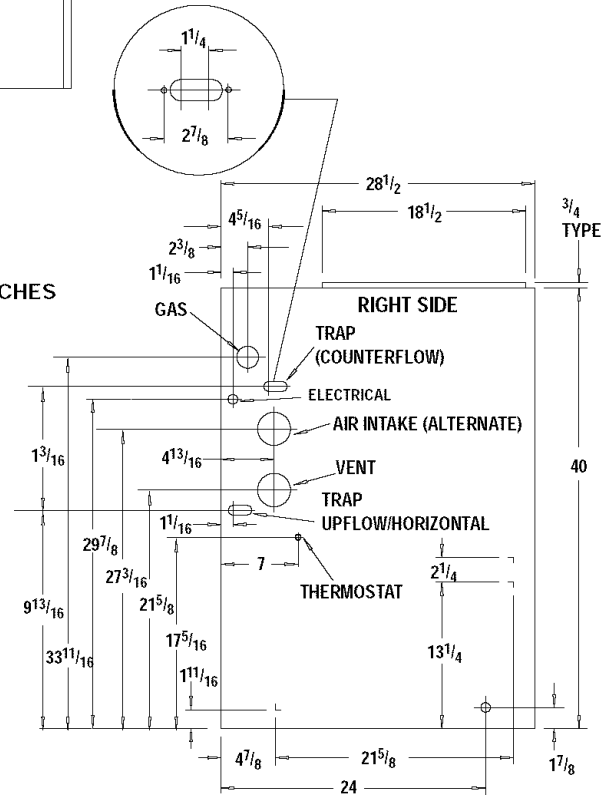

25-23-36b

Horizontal Furnace Installation

This furnace can be installed horizontally in an attic, basement, crawl space, alcove, or suspended from a ceiling in a basement or utility room (See **Figure 4**). Do not install furnace on its back or in the reverse airflow positions as safety control operation will be adversely affected.

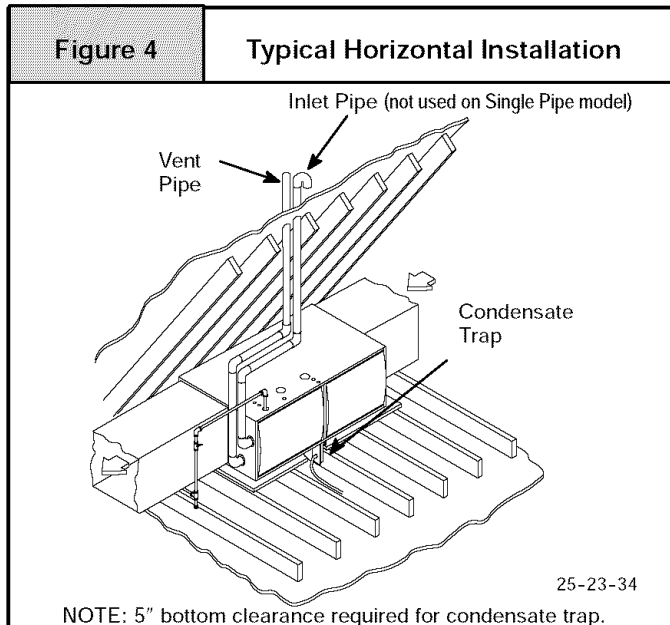

If the furnace is to be suspended from the floor joists in a crawl space or the rafters in an attic, it is necessary to use steel pipe straps or an angle iron frame to rigidly attach the furnace to prevent movement. These straps should be attached to the furnace with sheet metal screws and to the rafters or joists with bolts. The preferred method is to use an angle iron frame bolted to the rafters or joists. (Take caution to allow door panels to be removed for maintenance)

If the furnace is to be installed in a crawl space, consult local codes. A suitable concrete pad or blocks are recommended for crawl space installation on the ground.

NOTE: 6" bottom clearance required for condensate trap.

Thirty (30) inches between the front of the furnace and adjacent construction or other appliances **MUST** be maintained for service clearance.

Keep all insulating materials clear from louvered door. Insulating materials may be combustible.

The horizontal furnaces may be installed directly on combustible wood flooring or supports as long as all required furnace clearances are met. See **Figure 4**.

This furnace **MUST NOT** be installed directly on carpeting or tile or other combustible material other than wood flooring or supports.

For horizontal installation over a finished living space. A field fabricated auxiliary drain pan with drain pipe is required to prevent damage by overflow due to blocked condensate drain.

3. Combustion & Ventilation Air

For Single Pipe Installation

⚠ WARNING

CARBON MONOXIDE POISONING HAZARD

Failure to provide adequate combustion and ventilation air could result in death and/or personal injury.

Use methods described here to provide combustion and ventilation air.

Furnaces require ventilation openings to provide sufficient air for proper combustion and ventilation of flue gases. All duct or openings for supplying combustion and ventilation air must comply with National Fuel Gas Code, NFPA54/ANSI Z223.1, 2002 (or current edition) and applicable provisions of local building codes.

This furnace can NOT be common vented or connected to any type B, BW or L vent or vent connector, nor to any portion of a factory-built or masonry chimney. If this furnace is replacing a previously common-vented furnace, it may be necessary to resize the existing vent and chimney to prevent oversizing problems for the other remaining appliance(s). See "*Venting and Combustion Air Check*" in this section. This furnace **MUST** be vented to the outside.

Air Openings and Connecting Ducts

1. Total input rating for all non direct vent gas appliances **MUST** be considered when determining free area of openings.
2. Connect ducts or openings directly to outside.
3. When screens are used to cover openings, they **MUST** be no less than $\frac{1}{4}$ " mesh.
4. The minimum dimension of rectangular air ducts **MUST NOT** be less than 3".
5. When sizing grille or louver, use the free area of opening. If free area is **NOT** stamped or marked on grill or louver, assume a 20% free area for wood and 60% for metal.

Confined Space Installation

NOTE: A confined space is defined as an area with less than 50 cubic feet per 1,000 BTUH input rating for all gas appliances installed in the area.

Requirements

1. Provide confined space with sufficient air for proper combustion and ventilation of flue gases using horizontal or vertical ducts or openings.
2. **Figure 5** illustrate how to provide combustion and ventilation air. A minimum of two permanent openings, one inlet and one outlet, are required.

Figure 5

Outside Air (This is ONLY a guide. Subject to codes of country having jurisdiction.)

This installation NOT approved in Canada

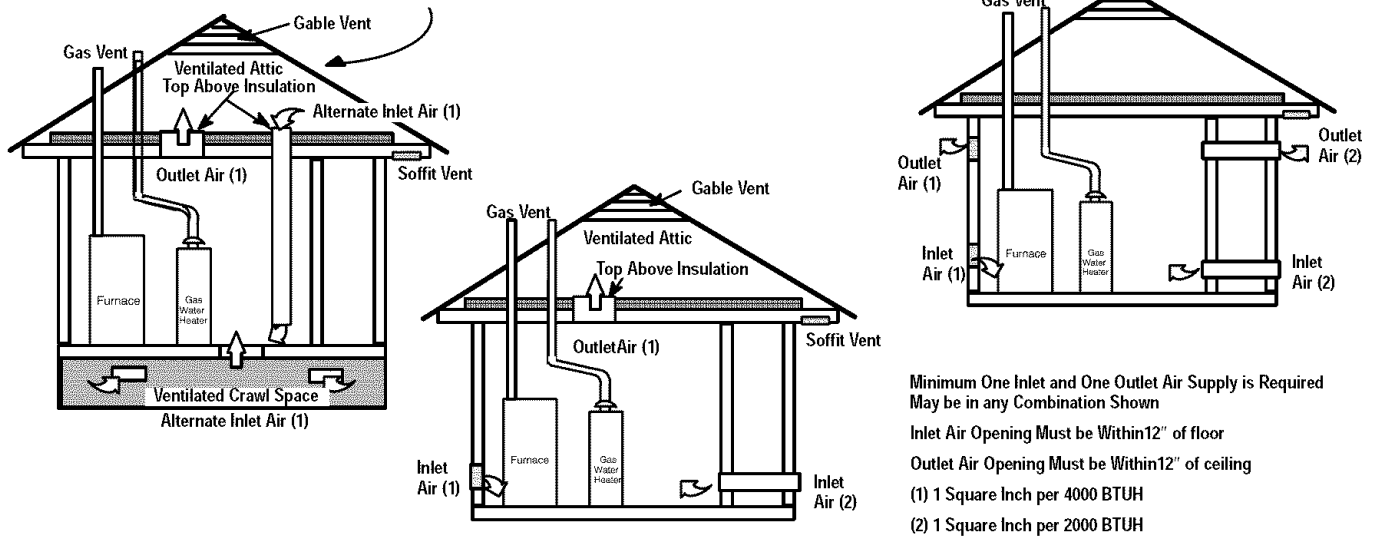

3. One opening **MUST** be within 12" of the floor and the second opening within 12" of the ceiling.
4. Size openings and ducts per Table 1.
5. Horizontal duct openings require 1 square inch of free area per 2,000 BTUH of combined input for all gas appliances in area (see Table 1).
6. Vertical duct openings or openings directly to outside require 1 square inch of free area per 4,000 BTUH for combined input of all gas appliances in area (see Table 1).

Table 1		Free Area		
BTUH Input Rating	Minimum Free Area Required for Each Opening			Round Duct (4,000 BTUH)
	Horizontal Duct (2,000 BTUH)	Vertical Duct or openings to outside (4,000 BTUH)		
50,000	25 sq. in.	12.5 sq. in.		4"
75,000	37.5 sq. in.	18.75 sq. in.		5"
100,000	50 sq. in.	25 sq. in.		6"
125,000	62.5 sq. in.	31.25 sq. in.		7"
150,000	75 sq. in.	37.5 sq. in.		7"

EXAMPLE: Determining Free Area

Appliance 1	Appliance 2	Total Input
100,000	+ 30,000	= (130,000 ÷ 4,000) = 32.5 Sq. In. Vertical
Appliance 1	Appliance 2	Total Input
100,000	+ 30,000	= (130,000 ÷ 2,000) = 65 Sq. In. Horizontal

One permanent opening, commencing within 12" of the top of the enclosure, shall be permitted where the equipment has clearances of at least 1" from the sides and back and 6" from the front of the appliance. The opening shall directly communicate with the outdoors or shall communicate through a vertical or horizontal duct to the outdoors or spaces (crawl or attic) that freely communicate with the outdoors, and shall have a minimum free area of:

- 1 sq. in per 3000 Btu per hr. of the total input rating of all equipment located in the enclosure, and
- Not less than the sum of the areas of all vent connectors in the confined space.

Unconfined Space Installation

⚠ WARNING

CARBON MONOXIDE POISONING HAZARD

Failure to supply additional air by means of ventilation grilles or ducts could result in death and/or personal injury.

An unconfined space or homes with tight construction may not have adequate air infiltration for proper combustion and ventilation of flue gases.

Most homes will require additional air.

An unconfined space is defined as an area having a minimum volume of 50 cubic feet per 1,000 Btu total input rating for all gas appliances in area. Refer to Table 2 for minimum area required.

Table 2		Unconfined Space Minimum Area in Square Feet
BTUH Input Rating	Minimum Area in Square Feet	
50,000	312	
78,000	490	
114,000	712	
155,000	968	

EXAMPLE: NOTE: Square feet is based on 8 foot ceilings.

$$\frac{28,000 \text{ BTUH}}{1,000} \times 50 \text{ Cubic Ft.} = \frac{1,400}{8' \text{ Ceiling Height}} = 175 \text{ Sq. Ft.}$$

NOTE: Refer to definitions in section titled *Unusually Tight Construction*. If any *one* of the conditions apply, the space **MUST** be considered confined space regardless of size.

1. Adjoining rooms can be considered part of an unconfined area if there are openings without doors between rooms.
2. An attic or crawl space may be considered an unconfined space provided there are adequate ventilation openings directly to outdoors. Openings **MUST** remain open and **NOT** have any means of being closed off. Ventilation openings to outdoors **MUST** be at least 1" square of free area per 4,000 BTUH of total input rating for all gas appliances in area.

3. Install air intake a minimum of 12" above maximum snow level and clear of any obstruction. Duct or ventilation opening requires one square inch of free area per 4,000 BTUH of total input rating for all gas appliances in area.
4. Air inlet **MUST** be screened with not less than 1/4" mesh screen.

Unusually Tight Construction

In unconfined spaces, infiltration may be adequate to provide air for combustion, ventilation and dilution of flue gases. However, in buildings with unusually tight construction, additional air **MUST** be provided using the methods described in section titled *Confined Space Installation*:

Unusually tight construction is defined as: Construction with

1. Walls and ceilings exposed to the outside have a continuous, sealed vapor barrier. Openings are gasketed or sealed and
2. Doors and openable windows are weather stripped and
3. Other openings are caulked or sealed. These include joints around window and door frames, between sole plates and floors, between wall-ceiling joints, between wall panels, at penetrations for plumbing, electrical and gas lines, etc.

Ventilation Air

Some provincial codes and local municipalities require ventilation or make-up air be brought into the conditioned space as replacement air. Whichever method is used, the mixed return air temperature across the heat exchanger **MUST** not fall below 60°F or flue gases will condense in the heat exchanger. This will shorten the life of the heat exchanger and possibly void your warranty.

Venting and Combustion Air Check

The following information is supplied to allow the installer to make adjustments to the setup of existing appliances, **IF REQUIRED**, based on good trade practices, local codes, and good judgement of the installer. Manufacturer does **NOT** take responsibility for modifications made to existing equipment.

NOTE: If this installation replaces an existing furnace from a commonly vented system, the original venting system may no longer be sized to properly vent the attached appliances. An improperly sized venting system may cause the formation of condensate in the vent and the leakage or spillage of vent gases. To make sure there is adequate combustion air for all appliances, **MAKE THE FOLLOWING CHECK.**

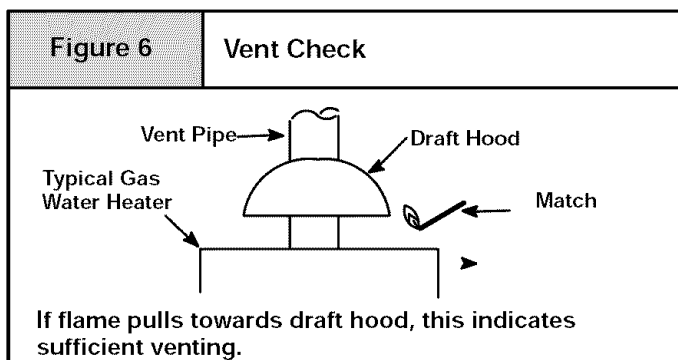

⚠ **WARNING**

CARBON MONOXIDE POISONING HAZARD

Failure to follow the steps outlined below for each appliance connected to the venting system being placed into operation, could result in carbon monoxide poisoning or death:

The following steps shall be followed for each appliance connected to the venting system being placed into operation, while all other appliances connected to the venting system are not in operation:

1. Seal any unused openings in the venting system.
2. Inspect the venting system for proper size and horizontal pitch, as required in the *National Fuel Gas Code, ANSI Z223.1/NFPA 54* or *CSA B149.1, Natural Gas and Propane Installation Code* and these instructions. Determine that there is no blockage or restriction, leakage, corrosion and other deficiencies which could cause an unsafe condition.
3. As far as practical, close all building doors and windows and all doors between the space in which the appliance(s) connected to the venting system are located and other spaces of the building.
4. Close fireplace dampers.
5. Turn on clothes dryers and any appliance not connected to the venting system. Turn on any exhaust fans, such as range hoods and bathroom exhausts, so they are operating at maximum speed. Do not operate a summer exhaust fan.
6. Follow the lighting instructions. Place the appliance being inspected into operation. Adjust the thermostat so appliance is operating continuously.
7. Test for spillage from draft hood equipped appliances at the draft hood relief opening after 5 minutes of main burner operation. Use the flame of a match or candle. (**Figure 6**)
8. If improper venting is observed, during any of the above tests, the venting system must be corrected in accordance with the *National Fuel Gas Code, ANSI Z223.1/NFPA 54* and/or *CSA B149.1, Natural Gas and Propane Installation Code*.
9. After it has been determined that each appliance connected to the venting system properly vents when tested as outlined above, return doors, windows, exhaust fans, fireplace dampers and any other gas-fired burning appliance to their previous conditions of use.

For Two Pipe Installation

This furnace can NOT be common vented or connected to any type B, BW or L vent or vent connector, nor to any portion of a factory-built or masonry chimney. If this furnace is replacing a previously common-vented furnace, it may be necessary to resize the existing vent and chimney to prevent oversizing problems for the other remaining appliance(s). See "*Venting and Combustion Air Check*" in this section. This furnace **MUST** be vented to the outside.

4. Vent and Combustion Air Piping



WARNING

CARBON MONOXIDE POISONING HAZARD.

Failure to properly vent this furnace could result in death and/or personal injury.

Use methods described here to provide combustion and ventilation air.

Dual Certified (*9MPT & *9MPV Models)

This furnace is certified as a category IV appliance. This furnace can be installed as a direct vent furnace using outside air for combustion or the furnace can use air from inside the structure for combustion. The **INLET** air pipe is optional. If combustion air comes from inside the structure, adequate make up air **MUST** be provided to compensate for oxygen burned. See *Confined Space Installation* in the *Combustion and Ventilation Air* chapter. If combustion air is drawn from outside the structure, it **MUST** be taken from the same atmospheric pressure zone as the vent pipe.

Contaminated Combustion Air

Installations in certain areas or types of structures will increase the exposure to chemicals or halogens that may harm the furnace.

The following areas or types of structures may contain or have exposure to the substances listed below. The installation must be evaluated carefully as it may be necessary to provide outside air for combustion.

- Commercial buildings.
- Buildings with indoor pools.
- Furnaces installed in laundry rooms.
- Furnaces installed in hobby or craft rooms.
- Furnaces installed near chemical storage areas.
- Permanent wave solutions for hair.
- Chlorinated waxes and cleaners.
- Chlorine based swimming pool chemicals.
- Water softening chemicals.
- De-icing salts or chemicals.
- Carbon tetrachloride.
- Halogen type refrigerants.
- Cleaning solvents (such as perchloroethylene).
- Printing inks, paint removers, varnishes, etc.
- Hydrochloric acid.
- Sulfuric Acid.
- Solvent cements and glues.
- Antistatic fabric softeners for clothes dryers.
- Masonry acid washing materials.

Vent and Combustion Air Piping Guidelines

NOTE: All vent piping **MUST** be installed in compliance with local codes or ordinances, these instructions, good trade practices, and codes of country having jurisdiction.

1. Determine the best routing and termination for the vent pipe and air inlet pipe by referring to all of the instructions and guidelines in this Section.
2. Determine the size required for the vent pipe and air inlet pipe.
3. Loosely assemble all venting parts without adhesive (pipe joint cement) for correct fit before final assembly.
4. Use of vertical piping is preferred because there will be some moisture in the flue gases that may condense as it leaves the vent pipe (See *Special Instruction For Horizontal Vents*).
5. The vertical vent pipe **MUST** be supported so that no weight is allowed to rest on the combustion blower.
6. Exhaust vent piping or air inlet piping diameter **MUST NOT** be reduced.
7. All exhaust vent piping from the furnace to termination **MUST** slope upwards. A minimum of $\frac{1}{4}$ " per foot of run is required to properly return condensate to the furnace drain system.
8. Use DWV type long radius elbows whenever possible, as they provide for the minimum slope on horizontal runs and they provide less resistance in the vent system. If DWV elbows cannot be used, use two, 45° elbows when possible. On horizontal runs the elbows can be slightly misaligned to provide the correct slope.
9. All horizontal pipe runs **MUST** be supported at least every five feet with galvanized strap or other rust resistant material. **NO** sags or dips are permitted.
10. All vertical pipe runs **MUST** be supported every six feet where accessible.
11. The maximum pipe length is 40' total in the inlet *or* outlet side of the system. Up to five, 90° elbows can be used on the inlet *or* the outlet. With the Concentric Vent Termination Kits (NAHA001CV or NAHA002CV), the maximum pipe length is 35' with 4 90° elbows. If more elbows are required, reduce the length of both the inlet and exhaust pipes 5' for each additional elbow used. (See **Table 3** or **Table 4**).
12. The minimum pipe run length is 2'.
13. The piping can be run in the same chase or adjacent to supply or vent pipe for water supply or waste plumbing. It can also be run in the same chase with a vent from another 90+ furnace.
NOTE: In **NO** case can the piping be run in a chase where temperatures can exceed 140° F. or where radiated heat from adjacent surfaces would exceed 140° F.
14. The vent outlet **MUST** be installed to terminate in the same atmospheric pressure zone as the combustion air inlet.
15. The vent system can be installed in an existing unused chimney provided that:
 - Both the exhaust vent and air intake run the length of the chimney.
 - No other gas fired appliance or fireplace (solid fuel) is vented into the chimney.
 - The top of the chimney **MUST** be sealed flush or crowned up to seal against rain or melting snow so **ONLY** the piping protrudes.
 - The termination clearances shown in **Figure 7** are maintained.
16. Furnace applications with vertical vents requiring vent diameter increaser fittings **must** have increaser fittings installed in vertical portion of the vent. Condensate will be trapped in the vent if the vent diameter is increased prior to having an elbow turned upward. This could cause nuisance tripping of the pressure switch.

Piping Insulation Guidelines

NOTE: Use closed cell, neoprene insulation or equivalent. If Fiber-glass or equivalent insulation is used it must have a vapor barrier. Use R values of 7 up to 10', R-11 if exposure exceeds 10'. If Fiber-glass insulation is used, exterior to the structure, the pipe **MUST** be boxed in and sealed against moisture.

1. When the vent or combustion air pipe height above the roof exceeds 30", or if an exterior vertical riser is used on a horizontal vent to get above snow levels, the exterior portion **MUST** be insulated.
2. When combustion air inlet piping is installed above a suspended ceiling, the pipe **MUST** be insulated with moisture resistant insulation such as Armaflex or other equivalent type of insulation.
3. Insulate combustion air inlet piping when run in warm, humid spaces such as basements.

Sizing Combustion Air and Vent Pipe

Consult Table 3 or Table 4 to select the proper diameter exhaust and combustion air piping. Exhaust and combustion air piping is sized for each furnace Btuh size based on total lineal vent length (on inlet *or* outlet side), and number of 90° elbows required.

1. **Double Pipe Installation**-If installing as a direct-vent appliance, consult **Table 4** to select the proper diameter exhaust and combustion air piping. Exhaust and combustion air piping is sized for each furnace Btuh size based on total lineal vent length (on inlet *or* outlet side), and number of 90° elbows required.
2. **Single Pipe Installation**-If installing as a non-direct vent appliance, (single outlet pipe and no inlet pipe) refer to **Table 3**. The table shows the maximum number of elbows allowed with any given pipe diameter and length of run.
3. **Use of Elbows**-Two 45° elbows can be substituted for one 90° elbow. The elbow or elbows used for vent termination outside the structure **ARE** counted, including elbows needed to bring termination above expected snow levels. The elbow inside the furnace on the *9MPD **IS NOT** included in the count.

Table 3	Pipe Diameter Table Single Piping ONLY
	50,000 & 75,000 Btuh Furnaces
	40' & (5) 90° elbows with 2" PVC pipe or
	100,000 Btuh Furnace
	40' & (5) 90° elbows with 3" PVC pipe
	125,000 Btuh Furnace
	40' & (5) 90° elbows with 3" PVC pipe
	Elbows are DWV Long Radius Type for 2" and 3" vents.

If more than five elbows are required, reduce the length of both the inlet and exhaust pipes 5' for each additional elbow used.

NOTE: It is allowable to use larger diameter pipe and fitting than shown in the tables but **not** smaller diameters than shown.

Table 4	Pipe Diameter Table Dual Piping ONLY
	50,000 & 75,000 Btuh Furnaces
	40' & (5) 90° elbows with 2" PVC pipe or
	100,000 Btuh Furnace
	40' & (5) 90° elbows with 3" PVC pipe
	125,000 Btuh Furnace
	40' & (5) 90° elbows with 3" PVC pipe
	Elbows are DWV Long Radius Type for 2" and 3" vents.

If more than five elbows are required, reduce the length of both the inlet and exhaust pipes 5' for each additional elbow used.

*Feet of pipe is whichever pipe run is the longest, either inlet *or* outlet side.

For "**Concentric Termination Kit**" Venting table, see "**Section 11**" in this manual.

Vent Termination Clearances

⚠ WARNING

CARBON MONOXIDE POISONING, FIRE AND EXPLOSION HAZARD.

Failure to properly vent this furnace could result in death, personal injury and/or property damage.

Inlet and outlet pipes may NOT be vented directly above each other.

1. Determine termination locations based on clearances specified in following steps and as shown in **Figure 7, Figure 8, Figure 20, through Figure 27.**

For "**Concentric Termination Kit**" clearances, see **Figure 47, Figure 48, Figure 49, Figure 50 and Figure 51** in "**Section 10**" in this manual.

2. This furnace is Dual Certified and can be installed as a single pipe appliance (all combustion from inside the structure) or as a direct vent appliance where all combustion air is taken from outside the structure.
3. For Single Pipe installation refer to **Figure 8** for vent termination clearances.
4. For Direct Vent installation, refer to **Figure 7** for vent termination.

Figure 7

Direct Vent Termination Clearance

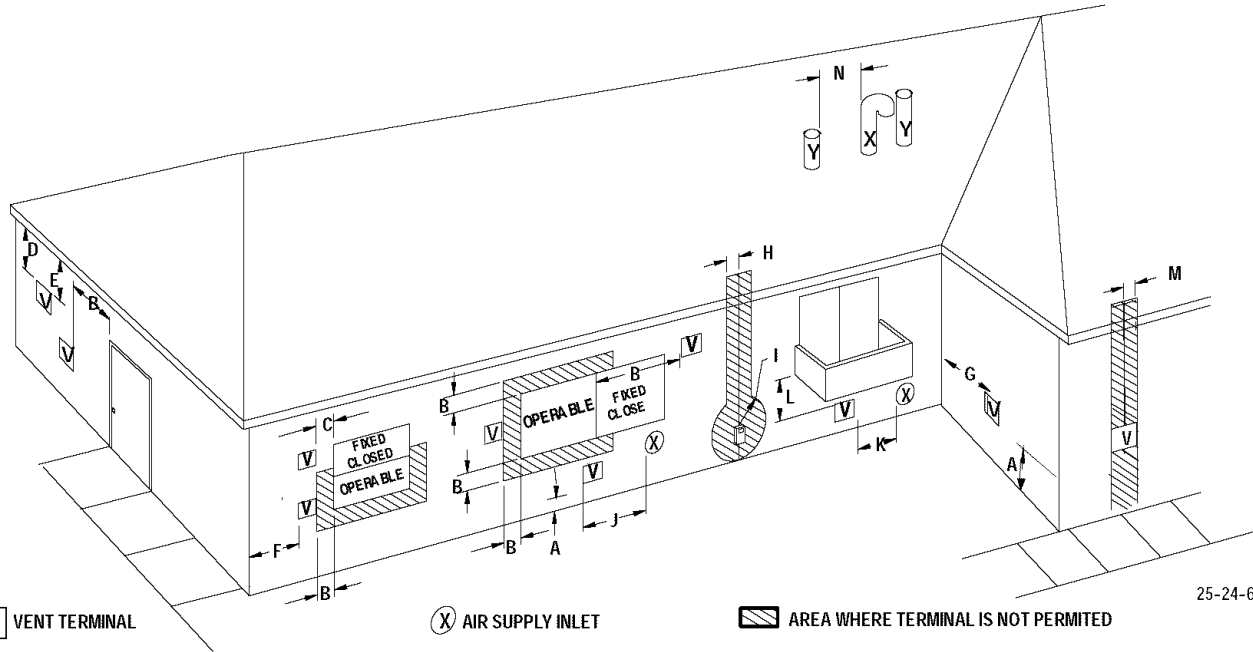

Item	Clearance Description	Canadian Installation (1)	U.S. Installation (2)
A	Clearance above grade, veranda, porch, deck, balcony, or anticipated snow level	12" (30cm) #	12" (30 cm)
B	Clearance to a window or door that may be opened	6" (15 cm) for appliances ≤ 10,000 BTUH (3kW), 12" (30 cm) for appliances > 10,000 Btuh (3 kW) and ≤ 100,000 Btuh (30 kW), 36" (91 cm) for appliances > 100,000 Btuh (30 kW)	6" (15 cm) for appliances ≤ 10,000 BTUH (3kW), 9" (23 cm) for appliances > 10,000 Btuh (3 kW) and ≤ 50,000 Btuh (15 kW), 12" (30 cm) for appliances > 50,000 Btuh (15 kW)
C	Clearance to a permanently closed window	*	*
D	Vertical clearance to a ventilated soffit located above the terminal within a horizontal distance of 2' (61cm) from the centerline of the terminal	*	*
E	Clearance to an unventilated soffit	*	*
F	Clearance to an outside corner	*	*
G	Clearance to an inside corner	*	*
H	Clearance to each side of the centerline extended above electrical meter or gas service regulator assembly	3' (91 cm) within 15' (4.5 m) above the meter/regulator assembly	3' (91 cm) within 15' (4.5 m) above the meter/regulator assembly
I	Clearance to service regulator vent outlet	3' (91 cm)	*
J	Clearance to non-mechanical air supply inlet to building or the combustion air inlet to any other appliance	6" (15 cm) for appliances ≤ 10,000 BTUH (3kW), 9" (23 cm) for appliances > 10,000 Btuh (3 kW) and ≤ 100,000 Btuh (30 kW) and ≤ 50,000 Btuh (15 kW), 12" (30 cm) for appliances > 50,000 Btuh (15 kW)	6" (15 cm) for appliances ≤ 10,000 BTUH (3kW), 9" (23 cm) for appliances > 10,000 Btuh (3 kW) and ≤ 50,000 Btuh (15 kW), 12" (30 cm) for appliances > 50,000 Btuh (15 kW)
K	Clearance to a mechanical air supply inlet	6' (1.83 m)	3' (91 cm) above if within 10' (3m horizontally)
L	Clearance under a veranda, porch, deck, or balcony	12" (30 cm) +	*
M	Clearance to each side of the centerline extended above or below vent terminal of the furnace to a dryer or water heater vent, or other appliance's direct vent intake or exhaust.	12" (30 cm)	12" (30 cm)
N	Clearance from a plumbing vent stack	3' (91 cm)	3' (91 cm)

(1.) In accordance with the current CSA B149.1, Natural Gas and Propane Installation Code

(2.) In accordance with the current ANSI Z223.1/NFPA 54, National Fuel Gas Code

18" (46 cm) above roof surface

+ Permitted only if veranda, porch, deck, or balcony is fully open on a minimum of two sides beneath the floor.

* For clearances not specified in ANSI Z223.1/NFPA 54 or CSA B149.1, clearances shall be in accordance with local installation codes and the requirements of the gas supplier and the manufacture's installation instructions.

Notes:

1. The vent for this appliance shall not terminate
 - a. Over public walkways; or
 - b. Near soffit vents or crawl space vents or other areas where condensate or vapor could create a nuisance or hazard or property damage; or
 - c. Where condensate vapor could cause damage or could be detrimental to the operation of regulators, relief valves, or other equipment.
2. When locating vent terminations, consideration must be given to prevailing winds, location, and other conditions which may cause recirculation of the combustion products of adjacent vents. Recirculation can cause poor combustion, inlet condensate problems, and accelerated corrosion of the heat exchangers.

Figure 8

Other than Direct Vent Termination Clearance

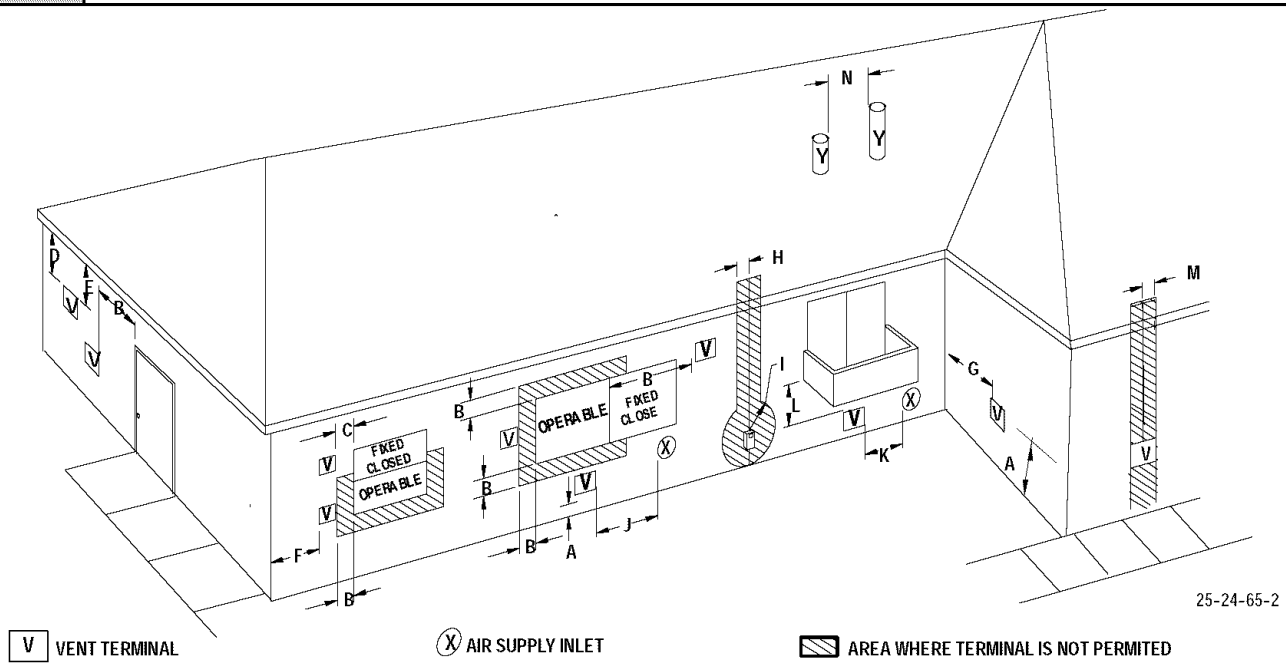

Item	Clearance Descriptions	Canadian Installation (1)	U.S. Installation (2)
A	Clearance above grade, veranda, porch, deck, balcony, or anticipated snow level	12" (30cm) #	12" (30 cm)
B	Clearance to a window or door that may be opened	6" (15 cm) for appliances ≤ 10,000 BTUH (3kW), 12" (30 cm) for appliances > 10,000 Btuh (3 kW) and ≤ 100,000 Btuh (30 kW), 36" (91 cm) for appliances > 100,000 Btuh (30 kW)	4' (1.2 m) below or to the side of the opening. 1' (30 cm) above the opening.
C	Clearance to a permanently closed window	*	*
D	Vertical clearance to a ventilated soffit located above the terminal within a horizontal distance of 2' (61cm) from the centerline of the terminal	*	*
E	Clearance to an unventilated soffit	*	*
F	Clearance to an outside corner	*	*
G	Clearance to an inside corner	*	*
H	Clearance to each side of the centerline extended above electrical meter or gas service regulator assembly	3' (91 cm) within 15' (4.5 m) above the meter/regulator assembly	3' (91 cm) within 15' (4.5 m) above the meter/regulator assembly
I	Clearance to service regulator vent outlet	3' (91 cm)	*
J	Clearance to non-mechanical air supply inlet to building or the combustion air inlet to any other appliance	6" (15 cm) for appliances ≤ 10,000 BTUH (3kW), 12" (30 cm) for appliances > 10,000 Btuh (3 kW) and ≤ 100,000 Btuh (30 kW), 36" (91 cm) for appliances > 100,000 Btuh (30 kW)	4' (1.2 m) below or to the side of opening. 1' (30 cm) above opening.
K	Clearance to a mechanical air supply inlet	6' (1.83 m)	3' (91 cm) above if within 10' (3m horizontally)
L	Clearance under a veranda, porch, deck, or balcony	12" (30 cm) +	*
M	Clearance to each side of the centerline extended above or below vent terminal of the furnace to a dryer or water heater vent, or other appliance's direct vent intake or exhaust.	*	*
N	Clearance from a plumbing vent stack	3' (91 cm)	3' (91 cm)

(1.) In accordance with the current CSA B149.1, Natural Gas and Propane Installation Code

(2.) In accordance with the current ANSI Z223.1/NFPA 54, National Fuel Gas Code

18" (46 cm) above roof surface

+ Permitted only if veranda, porch, deck, or balcony is fully open on a minimum of two sides beneath the floor.

* For clearances not specified in ANSI Z223.1/NFPA 54 or CSA B149.1, clearances shall be in accordance with local installation codes and the requirements of the gas supplier and the manufacturer's installation instructions.

Notes:

1. The vent for this appliance shall not terminate
 - a. Over public walkways; or
 - b. Near soffit vents or crawl space vents or other areas where condensate or vapor could create a nuisance or hazard or property damage; or
 - c. Where condensate vapor could cause damage or could be detrimental to the operation of regulators, relief valves, or other equipment.
2. When locating vent terminations, consideration must be given to prevailing winds, location, and other conditions which may cause recirculation of the combustion products of adjacent vents. Recirculation can cause poor combustion, inlet condensate problems, and accelerated corrosion of the heat exchangers.

Condensate Drain Trap

This furnace removes both sensible and latent heat from the products of combustion. Removal of the latent heat results in condensation of the water vapor. The condensate is removed from the furnace through the drains in the plastic transition and the vent fitting. The drains connect to the factory installed internally mounted condensate drain trap on the left or right side of the furnace.

The startup of a new furnace will involve a cycle or two of the furnace to properly prime the condensate trap with water. Until the trap is fully primed, some condensate will be pulled into the combustion blower. The furnace may cycle on the pressure switch connected to the plastic transition box due to condensate buildup. After the trap is primed, the condensate will start draining from the furnace. The combustion blower will clear out any remaining condensate in the blower housing through the vent fitting downstream of the blower. Note that the condensate trap can also be primed by pouring water into the $\frac{1}{2}$ " drain hose. Remove the $\frac{1}{2}$ " ID drain hose from either the gutter or the white PVC Tee Trap. Using a funnel pour eight (8) ounces of water into $\frac{1}{2}$ " ID drain hose. Water will flow through the drain hose and into the condensate drain trap. This will prime both the vent and the transition sides of the trap. Reconnect the $\frac{1}{2}$ " ID drain hose to the original component, either the gutter or the PVC Tee Trap.

The condensate drain trap supplied with the furnace **MUST** be used. The drain connection on the condensate drain trap is sized for $\frac{3}{4}$ " PVC or CPVC pipe, however alternate $\frac{1}{2}$ " CPVC (nominal $\frac{5}{8}$ " O.D.) or vinyl tubing with a minimum inner diameter (I.D.) of $\frac{5}{8}$ " may also be used, as allowed by local codes. Alternate drain pipes and hoses may be used as allowed by local codes.

The drain line must maintain a $\frac{1}{4}$ " per foot downward slope toward the drain. $\frac{1}{4}$ " per foot is recommended. Installation of an overflow line is recommended when the $\frac{1}{4}$ " per foot slope to the condensate drain cannot be maintained. See **Figure 18** for proper routing and installation of the overflow.

DO NOT trap the drain line in any other location than at the condensate drain trap supplied with the furnace.

If possible **DO NOT** route the drain line where it may freeze. The drain line must terminate at an inside drain to prevent freezing of the condensate and possible property damage.

1. A condensate sump pump **MUST** be used if required by local codes, or if no indoor floor drain is available. The condensate pump must be approved for use with acidic condensate.
2. A plugged condensate drain line or a failed condensate pump will allow condensate to spill. If the furnace is installed where a condensate spill could cause damage, it is recommended that an auxiliary safety switch be installed to prevent operation of the equipment in the event of pump failure or plugged drain line. If used, an auxiliary safety switch should be installed in the R circuit (low voltage) **ONLY**.
3. If the auxiliary switch in the condensate pump is used, the furnace may shut down due to a blocked condensate line or failed pump. To prevent frozen water pipes see the "Frozen Water Pipe Hazard" section on Page 4 of this manual.

WARNING

FROZEN AND BURST WATER PIPE HAZARD

Failure to do so could result in burst water pipes, serious property damage and/or personal injury.

If a condensate pump is installed, a plugged condensate drain or a failed pump may cause the furnace to shut down. Do not leave the home unattended during freezing weather without turning off water supply and draining water pipes or otherwise protecting against the risk of frozen pipes.

Condensate Drain Trap Freeze Protection

Special precautions **MUST** be made if installing furnace in an area which may drop below freezing. This can cause improper operation or damage to the equipment. If the the furnace environment has the potential of freezing, the drain trap and drain line must be protected. Use 3 to 6 watt per foot at 115 volt, 40° F self-regulating shielded and waterproof heat tape. Wrap the drain trap and drain line with the heat tape and secure with the ties. Follow the heat tape manufacturer's recommendations.

Figure 9

Upflow Installations Top Vent

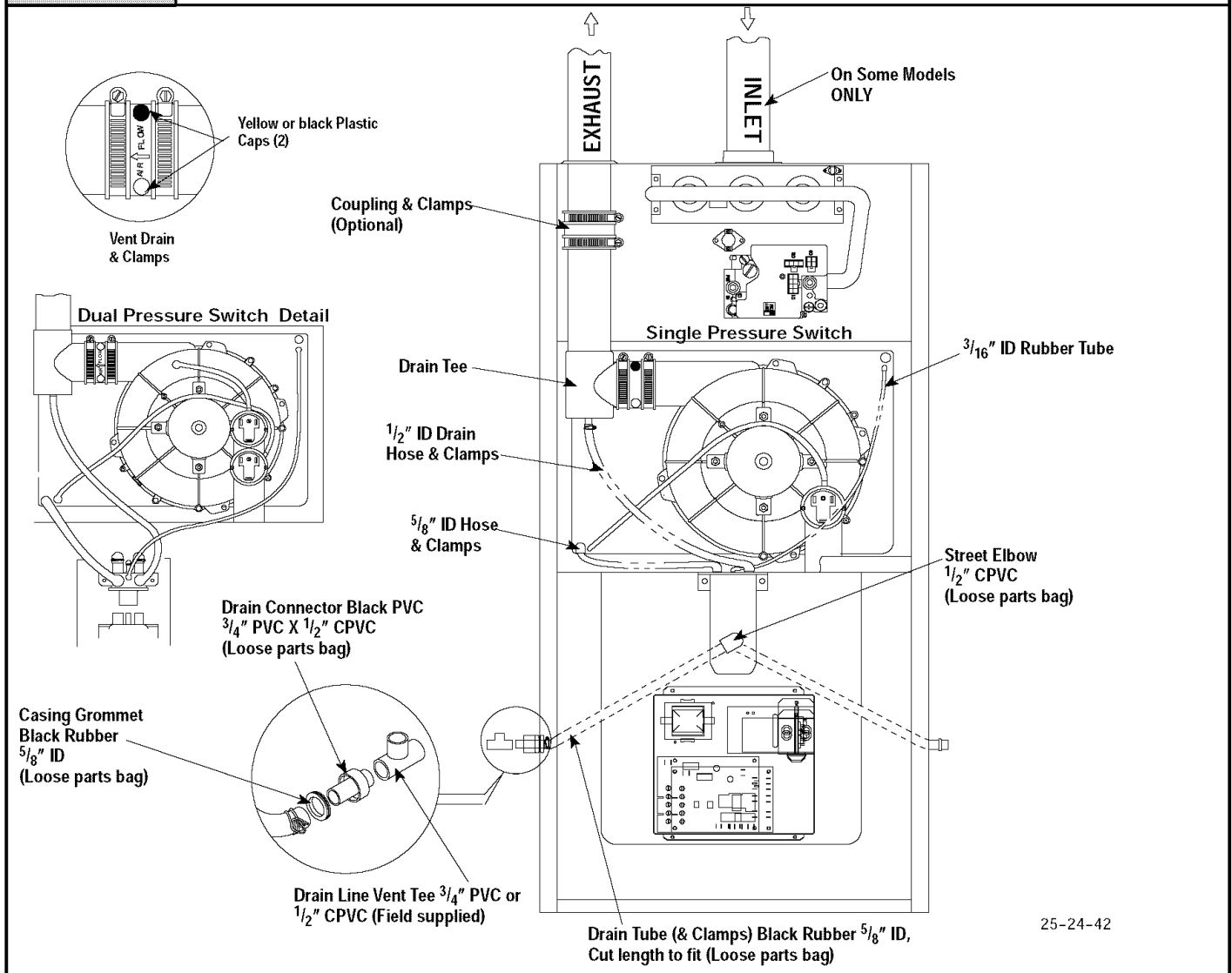

Upflow Installations Top Vent (See Figure 9)

Remove plug from the side of the furnace casing where Drain Tube will exit.

Install casing grommet (black rubber 5/8" ID grommet - in loose parts bag)

Install the 1/2" CPVC street elbow on discharge of Trap

Install the black PVC tube connector (3/4" PVC x 1/2" CPVC from loose parts bag) as shown in the illustration above.

Cut the black Drain Tube (5/8" ID - in loose parts bag) to length to fit between Trap and tube connector through grommet.

Clamp both ends of the Drain Tube using clamps provided.

Glue the CPVC street elbow to the Trap using appropriate cleaner and solvent cement.

Connect the Tee trap and the main drain line exiting the casing as shown **Figure 18**.

Note: It is recommended that all PVC piping and fitting connections be fit up and inspected before final cementing. **Trap must be primed before operation.** Verify all condensate drain connections are securely clamped. A coupling and clamps (in loose part bag) may be installed as shown for future servicing of the vent system.

Figure 10

Upflow Installations Vent thru Left Side

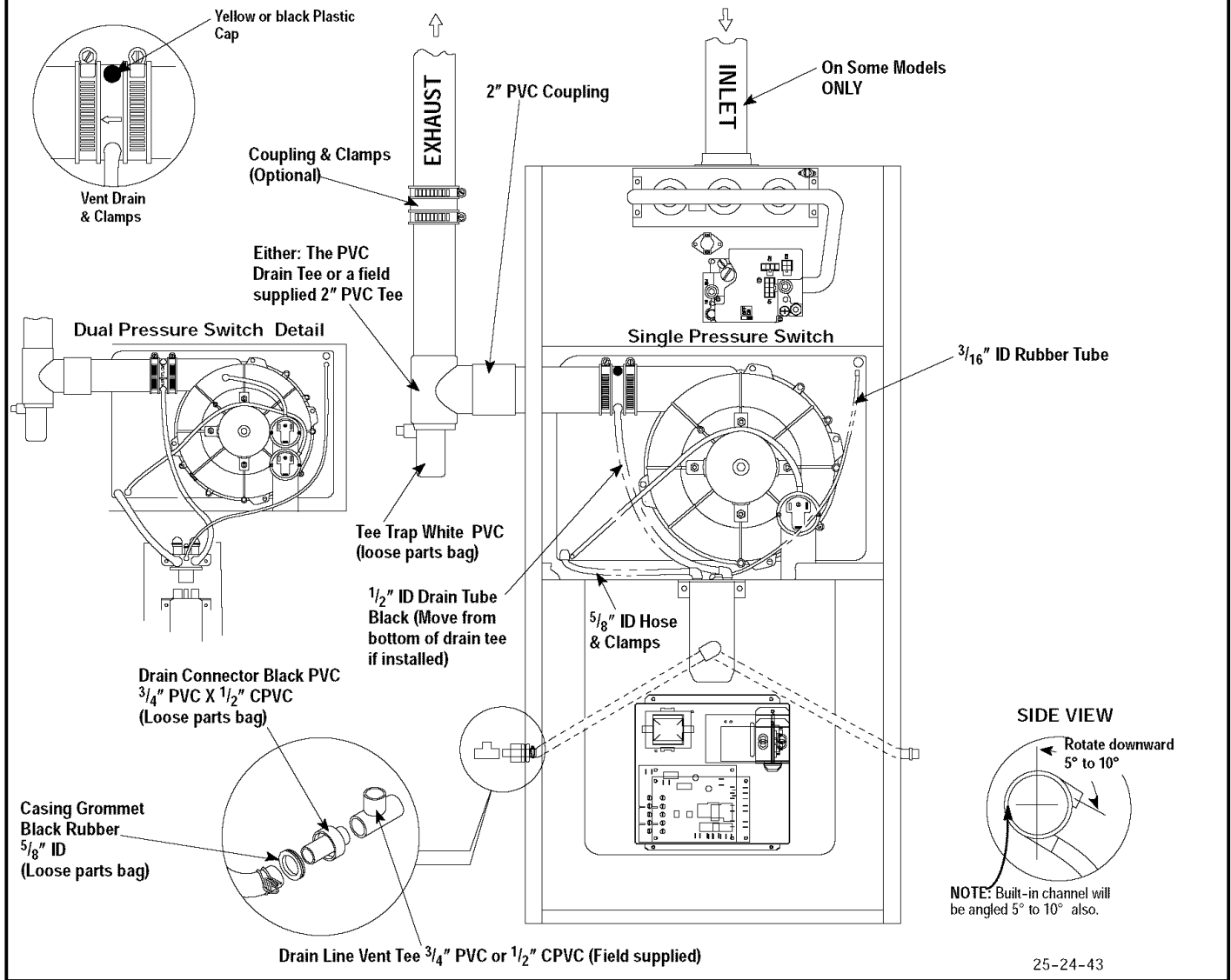

Upflow Installations Vent thru Left Side (See Figure 10)

Remove Drain Tee from inducer discharge and remove black Drain Tube ($1/2$ " ID) from bottom of Drain Tee. (*9MPT or V models only)

Install Vent Pipe grommet in side of casing.

Cut an appropriate length of 2" PVC pipe long enough to exit the cabinet and connect the vent drain to either:

- A 2" PVC coupling fastened onto the Drain Tee (*9MPT or V models)

Install Tee trap into bottom of tee.

Install the $1/2$ " CPVC street elbow on discharge of Trap

Install the black PVC drain connector ($3/4$ " PVC x $1/2$ " CPVC from loose parts bag) as shown in the illustration above.

Cut the black Drain Tube ($5/8$ " ID - in loose parts bag) to length to fit between Trap and tube connector through grommet.

Clamp both ends of the Drain Tube using clamps provided.

Glue the CPVC street elbow to the Trap using appropriate cleaner and solvent cement.

Connect the Tee trap and the main drain line exiting the casing as shown in Figure 18.

Note: It is recommended that all PVC piping and fitting connections be fit up and inspected before final cementing. **Both the internal Trap and the external Tee Trap must be primed before operation.** Verify all condensate drain connections are securely clamped. A coupling and clamps (in loose part bag) may be installed as shown for future servicing of the vent system.

Figure 11

All Models Vent thru Right Side

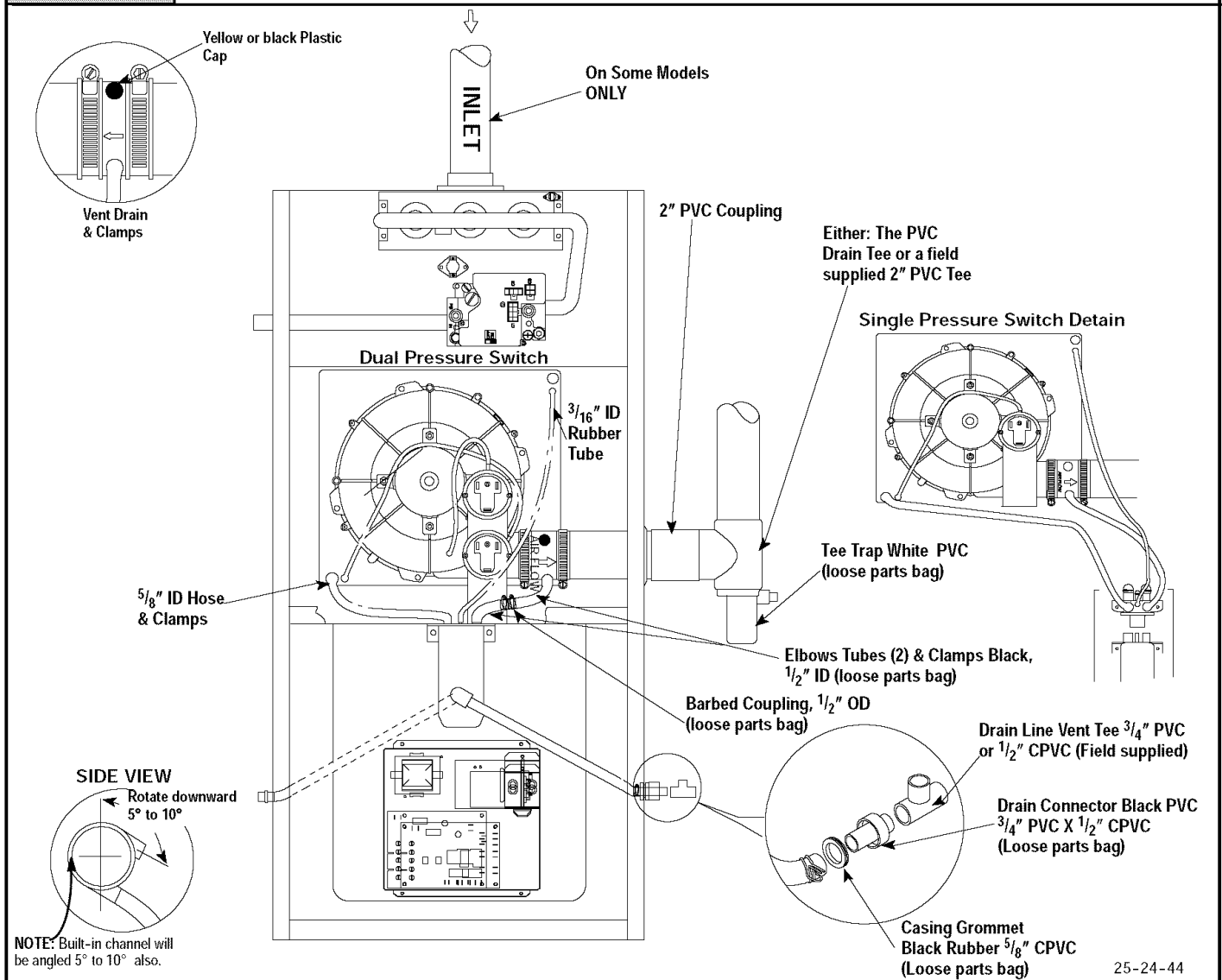

All Models Vent thru Right Side (See Figure 11)

Disconnect the black Drain Tube between the drain vent and the Trap.

Rotate the inducer 180° for a right side vent after loosening the 4 inducer attachment screws. Reinstall and retighten the inducer screws to 20" pounds torque.

Using the 1/2" OD barbed coupling in the loose parts bag connect together with the 2 short 1/2" ID elbow tubes and connect the lower discharge port of the vent drain to the Trap. Secure all connections with clamps.

Install the vent pipe grommet into the casing

Cut an appropriate length of 2" PVC pipe long enough to exit the cabinet and connect the vent drain to either:

- A 2" PVC coupling fastened onto the Drain Tee (*9MPD models)

Install Tee Trap into bottom section of Tee.

Remove plug from the side of the furnace casing where Drain Tube will exit.

Install casing grommet (black rubber 5/8" ID grommet - in loose parts bag)

Install the 1/2" CPVC street elbow on discharge of Trap

Install the black PVC tube connector (3/4" PVC x 1/2" CPVC from loose parts bag) as shown in the illustration above

Cut the black Drain Tube (5/8" ID - in loose parts bag) to length to fit between Trap and tube connector through grommet.

Clamp both ends of the Drain Tube using clamps provided.

Glue the CPVC street elbow to the Trap using appropriate cleaner and solvent cement.

Connect the Tee trap and the main drain line exiting the casing as shown in Figure 18.

Note: It is recommended that all PVC piping and fitting connections be fit up and inspected before final cementing. **Both the internal Trap and the external Tee Trap must be primed before operation.** Verify all condensate drain connections are securely clamped. A coupling and clamps (in loose part bag) may be installed as shown for future servicing of the vent system.

Figure 12

Downflow Left Side Vent and Trap

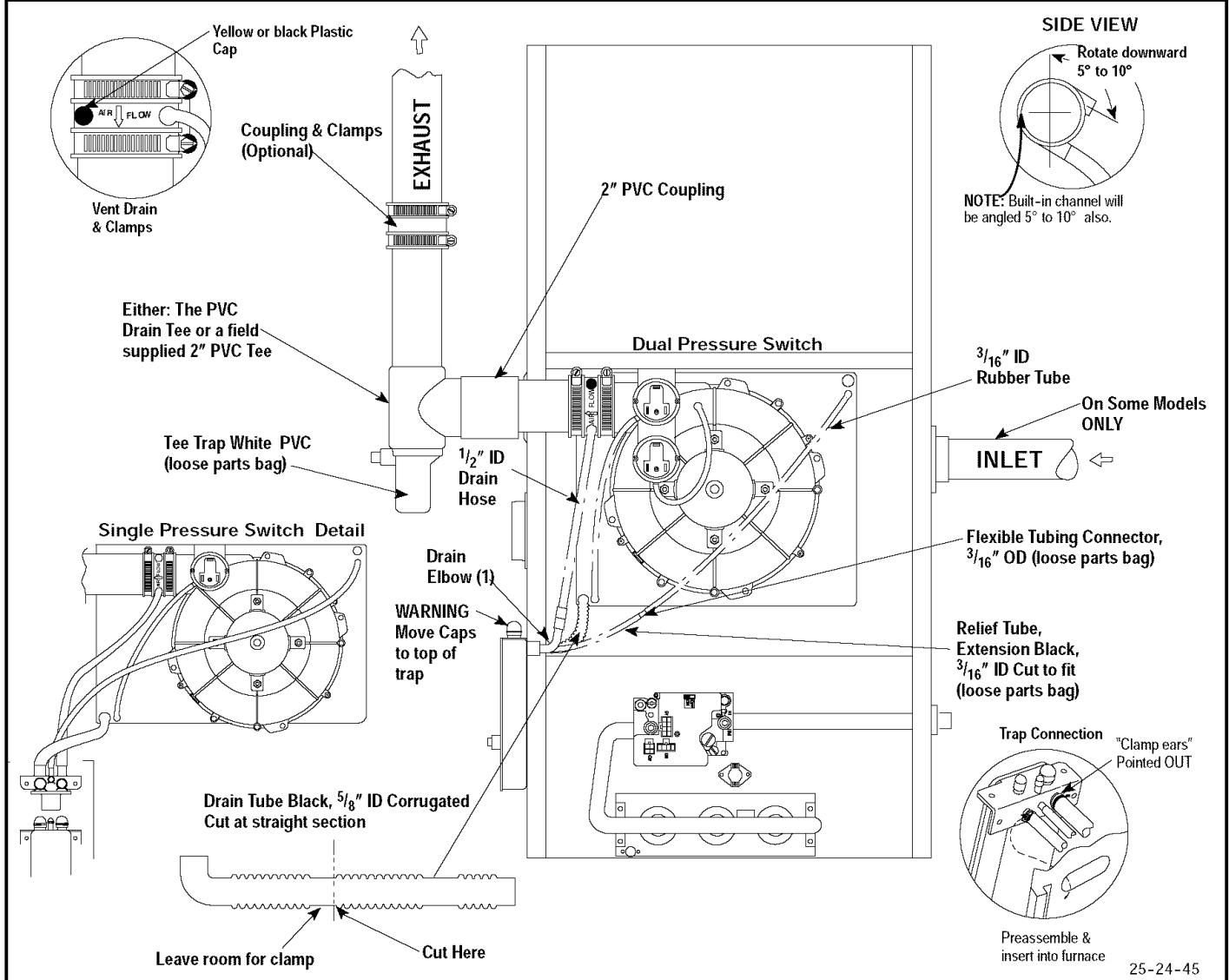

Downflow Left Side Vent and Trap (See Figure 12)

Remove the inducer mounting screws, rotate the inducer 180° and retighten the inducer screws to 20” pounds torque.

Disconnect the hoses from the Trap assembly, and remove Trap and Trap mounting bracket from the blower compartment. Using cover plate and gasket provided in the loose parts bag, cover the hole from the burner compartment to the blower compartment and secure with screws.

Move the caps to the top of the Trap and mount the Trap externally to the left side of the unit using the 2 screws provided.

Cut the 5/8” ID corrugated hose as shown above and fasten the 90° bend end to the Trap and fasten the straight end to the transition drain. Secure both connections with clamps.

Reconnect the 1/2” ID drain hose from the vent drain to the Trap and secure with a clamp. In some cases, additional length will be required for this hose. Use the Black plastic 1/2” OD barbed coupling and a suitable section of 1/2” ID hose to make the connection. Secure all connections with clamps

Connect the 3/16” ID relief tube from the small port on the Trap to the top port of the transition as shown in the picture. In some

cases, additional hose length will be needed. Use the clear plastic 3/16” OD flexible tubing connector and a suitable length of extra 3/16” ID hose to make this connection.

Install the vent pipe grommet into the casing

Cut an appropriate length of 2” PVC pipe long , enough to exit the cabinet and connect the vent drain to either:

- A 2” PVC coupling fastened onto the Drain Tee (*9MPT or V models)

Install Tee Trap into bottom section of Tee.

Connect the Tee trap and the main drain line exiting the casing as shown in **Figure 18**.

Note: It is recommended that all PVC piping and fitting connections be fit up and inspected before final cementing. **Both the external Trap and the external Tee Trap must be primed before operation.** Verify all condensate drain connections are securely clamped. A coupling and clamps (in loose part bag) may be installed as shown for future servicing of the vent system.

Figure 13

Downflow Right Side Vent and Trap

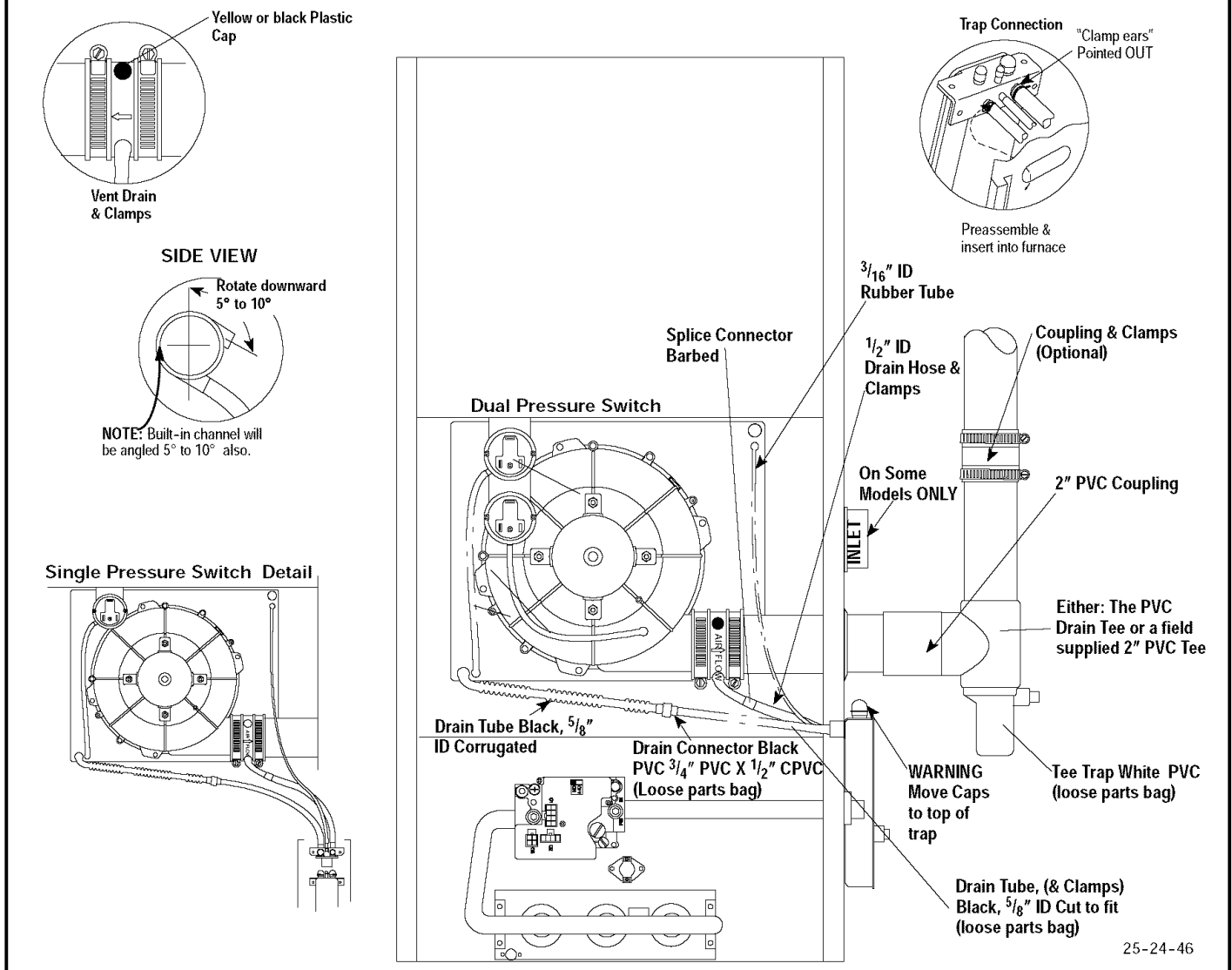

Downflow Right Side Vent and Trap (See Figure 13)

Remove the Drain Tee if installed.

Disconnect the hoses from the Trap assembly, and remove Trap and Trap mounting bracket from the blower compartment. Using cover plate and gasket provided in the loose parts bag, cover the hole from the burner compartment to the blower compartment and secure with screws.

Move the caps to the top of the Trap and mount the Trap externally to the right side of the unit using the 2 screws provided.

Connect the corrugated Drain Tube from the transition box to the Trap as shown. If an extension is required, use the black PVC tube connector and the black 5/8" ID Drain Tube in the loose parts bag. Cut tube to length. Secure all connections with clamps.

Connect the drain hose from the Vent Drain to the Trap. If an extension is required, use the black 1/2" OD barbed coupling, connect a black 1/2" ID elbow tube and a suitable section of a 1/2" ID

drain tube to make connection from the vent drain to the trap. Secure all connections with clamps.

Install the vent pipe grommet into the casing

Cut an appropriate length of 2" PVC pipe long, enough to exit the cabinet and connect the vent drain to either:

- A 2" PVC coupling fastened onto the Drain Tee (*9MPT or V models)

Install Tee Trap into bottom section of Tee.

Connect the Tee trap and the main drain line exiting the casing as shown in Figure 18.

Note: It is recommended that all PVC piping and fitting connections be fit up and inspected before final cementing. **Both the external Trap and the external Tee Trap must be primed before operation.** Verify all condensate drain connections are securely clamped. A coupling and clamps (in loose part bag) may be installed as shown for future servicing of the vent system.

Figure 14

Horizontal Left Thru Top

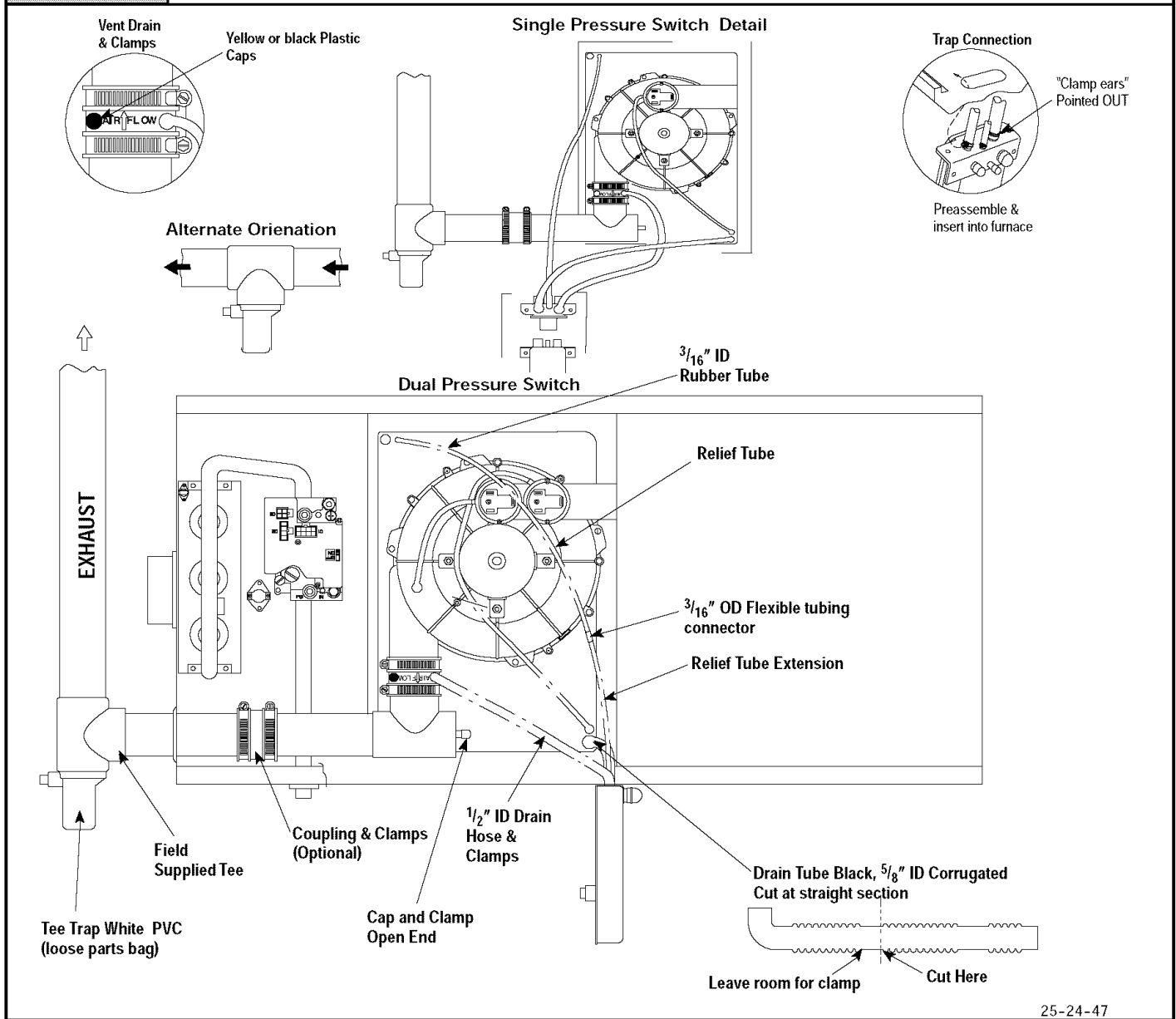

25-24-47

Horizontal Left-Thru Top (See Figure 14)

Disconnect the hoses from the Trap assembly, and remove Trap and Trap mounting bracket from the blower compartment. Using cover plate and gasket provided in the loose parts bag, cover the hole from the burner compartment to the blower compartment and secure with screws.

Mount the Trap externally to the bottom side of the unit using the 2 screws provided in the location shown.

Cut the corrugated tube as shown in the illustration above. Connect the corrugated hose from the transition to the Trap. Secure connections with clamps.

Remove the black 1/2" ID Drain Tube from the Drain Tee. Install a yellow cap and clamp over the open drain port of the Drain Tee.

Connect the black 1/2" ID Drain Tube from the Vent Drain to the Trap. Secure connections with clamps.

Connect the 3/16" ID relief tube to the middle port on the Trap. If an extension is required, use the 3/16" OD flexible tubing connector

and the black 3/16" ID relief tube in the loose parts bag. Cut tube to length. Secure all connections with clamps.

Cut an appropriate length of 2" PVC pipe, long enough to exit the cabinet and connect the vent drain to either:

- A 2" PVC coupling fastened onto the Drain Tee (*9MPT or V models)

Install Tee Trap into bottom section of Tee.

Connect the Tee trap and the main drain line exiting the casing as shown in Figure 18.

Note: It is recommended that all PVC piping and fitting connections be fit up and inspected before final cementing. **Both the external Trap and the external Tee Trap must be primed before operation.** Verify all condensate drain connections are securely clamped. A coupling and clamps (in loose part bag) may be installed as shown for future servicing of the vent system.

Figure 15

Horizontal Left-Side Vent

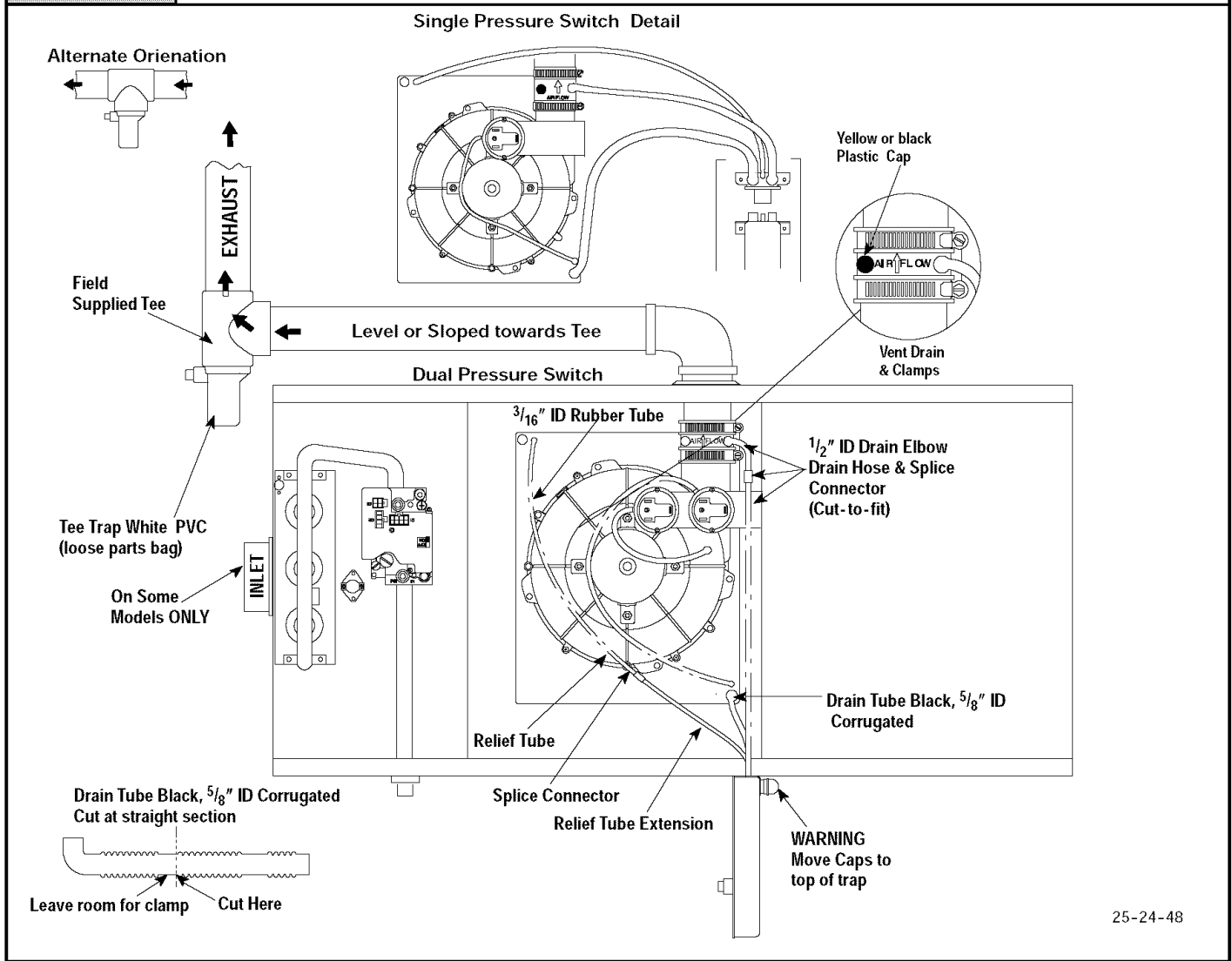

Horizontal Left-Side Vent (See Figure 15)

Remove the Drain Tee from the Vent Drain if installed (*9MPD models only)

Rotate the inducer 180° for a side vent after loosening the 4 inducer attachment screws. Reinstall and retighten the inducer screws to 20" pounds torque.

Disconnect the hoses from the Trap assembly, and remove Trap and Trap mounting bracket from the blower compartment. Using cover plate and gasket provided in the loose parts bag, cover the hole from the burner compartment to the blower compartment and secure with screws.

Mount the Trap externally to the bottom side of the unit using the 2 screws provided in the location shown.

Cut the corrugated tube as shown in the illustration above. Connect the corrugated hose from the transition to the Trap. Secure connections with clamps.

Connect the black 1/2" ID Drain Tube from the Vent Drain to the Trap. If an extension is required, use the black 1/2" OD flexible tubing connector and the black 1/2" ID Drain Tube in the loose parts bag. Cut tube to length. Secure connections with clamps.

Connect the 3/16" ID relief tube to the middle port on the Trap. If an extension is required, use the 3/16" OD flexible tubing connector

and the black 3/16" ID relief tube in the loose parts bag. Cut tube to length.

Cut an appropriate length of 2" PVC pipe, fittings and extension pipe long enough to exit the cabinet and connect the vent drain to either:

- A 2" PVC coupling fastened onto the Drain Tee (*9MPT or V models)

Install Tee Trap into bottom section of Tee.

Important: The pipe to the Tee Trap must be level or sloping towards the Tee Trap

Connect the Tee trap and the main drain line exiting the casing as shown in Figure 18.

Note: It is recommended that all PVC piping and fitting connections be fit up and inspected before final cementing. **Both the external Trap and the external Tee Trap must be primed before operation.** Verify all condensate drain connections are securely clamped. A coupling and clamps (in loose part bag) may be installed as shown for future servicing of the vent system.

A coupling and clamps (in loose part bag) may be installed as shown for future servicing of the vent system.

Figure 16

Horizontal Right thru Top

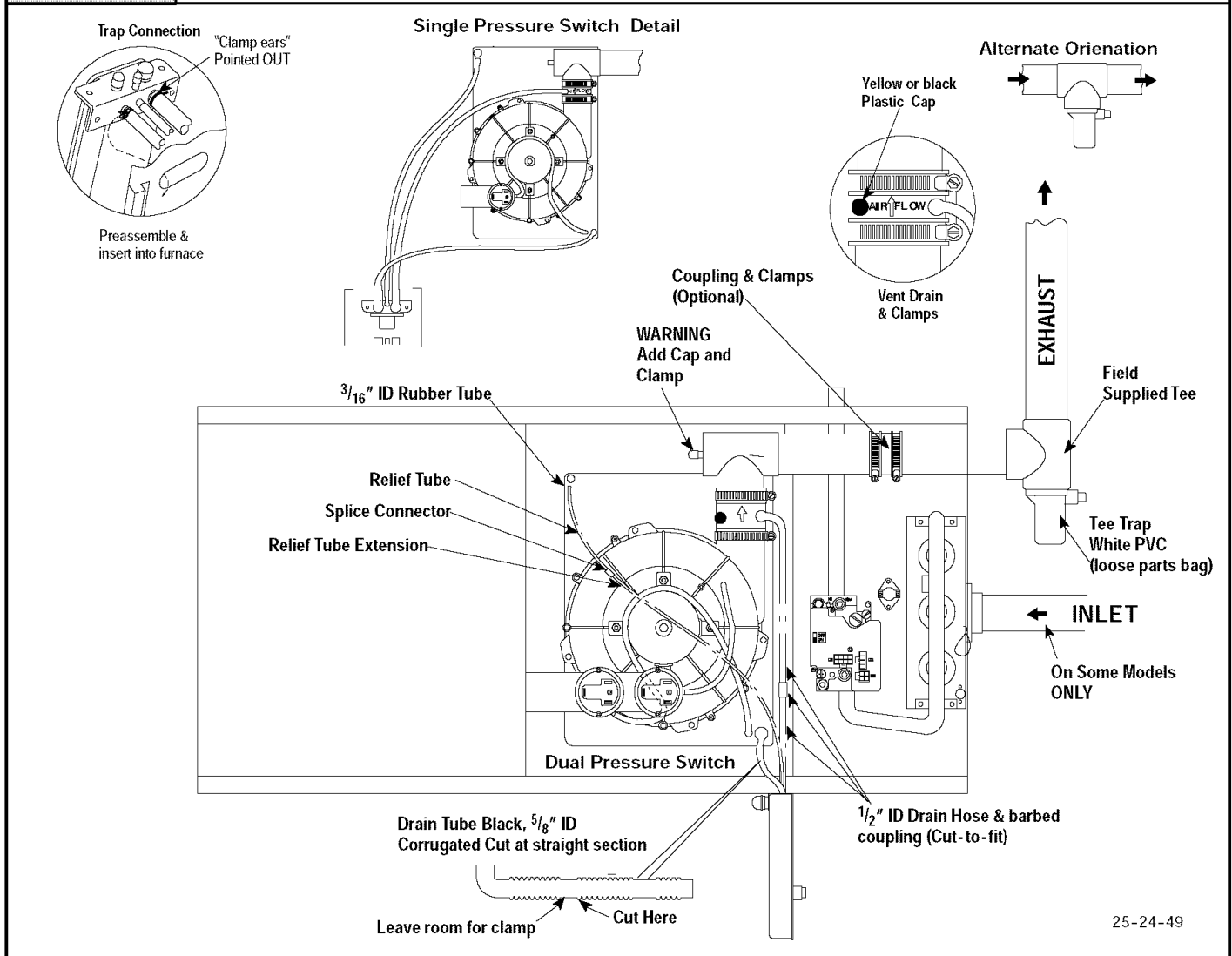

Horizontal Right Thru Top (See Figure 16)

Disconnect the hoses from the Trap assembly, and remove Trap and Trap mounting bracket from the blower compartment. Using cover plate and gasket provided in the loose parts bag, cover the hole from the burner compartment to the blower compartment and secure with screws.

Mount the Trap externally to the bottom side of the unit using the 2 screws provided in the location shown.

Cut the corrugated tube as shown in the illustration above. Connect the corrugated hose from the transition to the Trap. Secure connections with clamps.

Connect the black 1/2" ID Drain Tube from the Vent Drain to the Trap. If an extension is required, use the black 1/2" OD barbed coupling and the black 1/2" ID Drain Tube in the loose parts bag. Cut tube to length. Secure connections with clamps.

Connect the 3/16" ID relief tube to the middle port on the Trap. If an extension is required, use the clear 3/16" OD flexible tubing con-

nect and the black 3/16" ID relief tube in the loose parts bag. Cut tube to length.

Cut an appropriate length of 2" PVC pipe, fittings and extension pipe long enough to exit the cabinet and connect the vent drain to a standard field supplied 2" PVC tee

Install Tee Trap into bottom section of Tee.

Connect the Tee trap and the main drain line exiting the casing as shown in Figure 18.

Note: It is recommended that all PVC piping and fitting connections be fit up and inspected before final cementing. **Both the external Trap and the external Tee Trap must be primed before operation.** Verify all condensate drain connections are securely clamped. A coupling and clamps (in loose part bag) may be installed as shown for future servicing of the vent system.

Figure 17

Horizontal Right-Side Vent

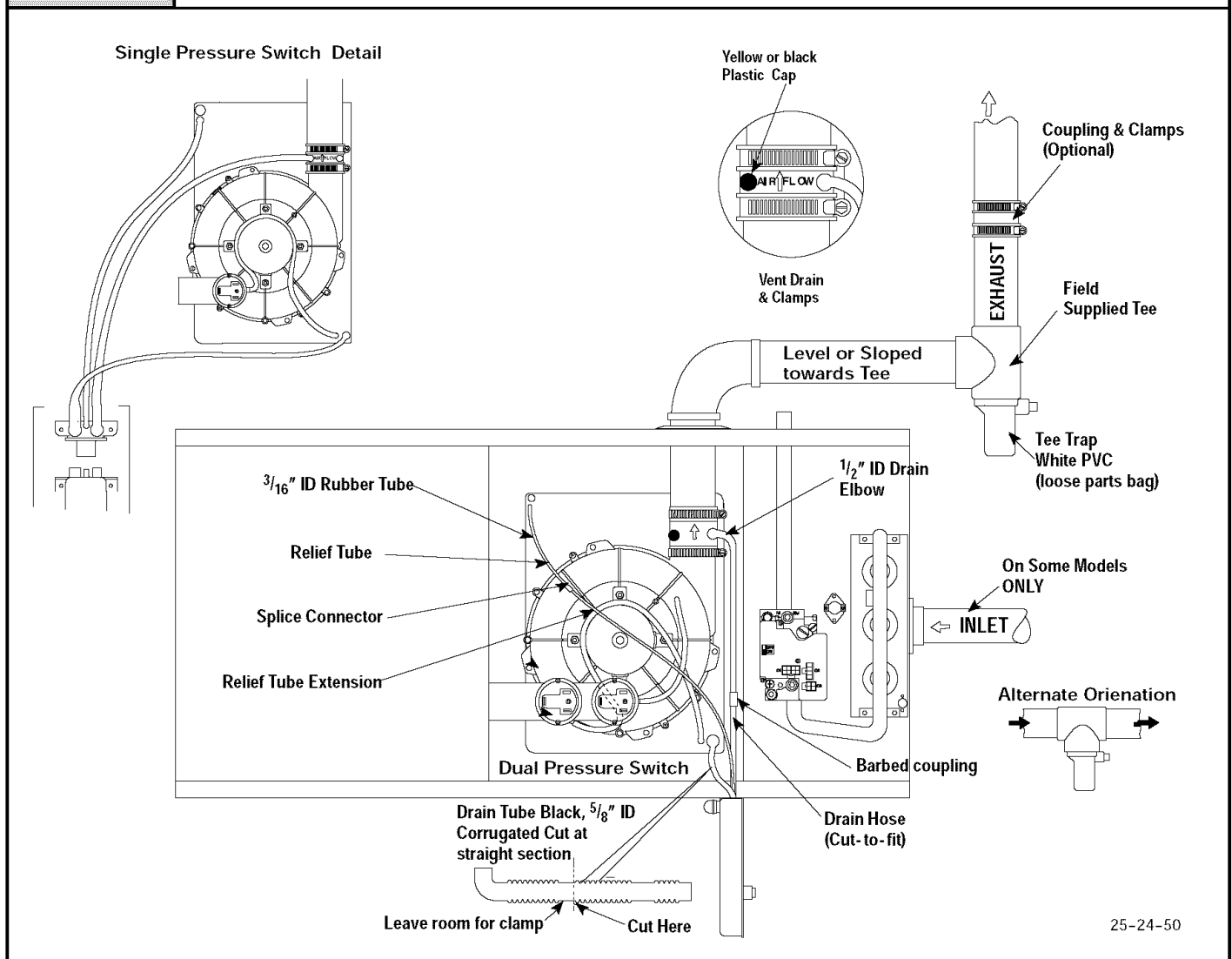

Horizontal Right Side Vent (See Figure 17)

Disconnect Drain Tee if installed (*9MPD models only)

Disconnect the hoses from the Trap assembly, and remove Trap and Trap mounting bracket from the blower compartment. Using cover plate and gasket provided in the loose parts bag, cover the hole from the burner compartment to the blower compartment and secure with screws.

Mount the Trap externally to the bottom side of the unit using the 2 screws provided in the location shown.

Cut the corrugated tube as shown in the illustration above. Connect the corrugated hose from the transition to the Trap. Secure connections with clamps.

Connect the black $\frac{1}{2}$ " ID Drain Tube from the Vent Drain to the Trap. If an extension is required, use the $\frac{1}{2}$ " OD barbed coupling and the black $\frac{1}{2}$ " ID Drain Tube in the loose parts bag. Cut tube to length. Secure connections with clamps.

Connect the $\frac{3}{16}$ " ID relief tube to the middle port on the Trap. If an extension is required, use the clear $\frac{3}{16}$ " OD splice connector

and the black $\frac{3}{16}$ " ID relief tube in the loose parts bag. Cut tube to length.

Cut an appropriate length of 2" PVC pipe, fittings and extension pipe long enough to exit the cabinet and connect the vent drain to either:

- A 2" PVC coupling fastened onto the Drain Tee (*9MPT or V models)

Install Tee Trap into bottom section of Tee.

Important: The pipe to the Tee Trap must be level or sloping towards the Tee Trap

Connect the Tee trap and the main drain line exiting the casing as shown in Figure 18.

Note: It is recommended that all PVC piping and fitting connections be fit up and inspected before final cementing. **Both the external Trap and the external Tee Trap must be primed before operation.** Verify all condensate drain connections are securely clamped. A coupling and clamps (in loose part bag) may be installed as shown for future servicing of the vent system.

Figure 18

Connecting Tee Trap to Condensate Trap and Main Drain Line

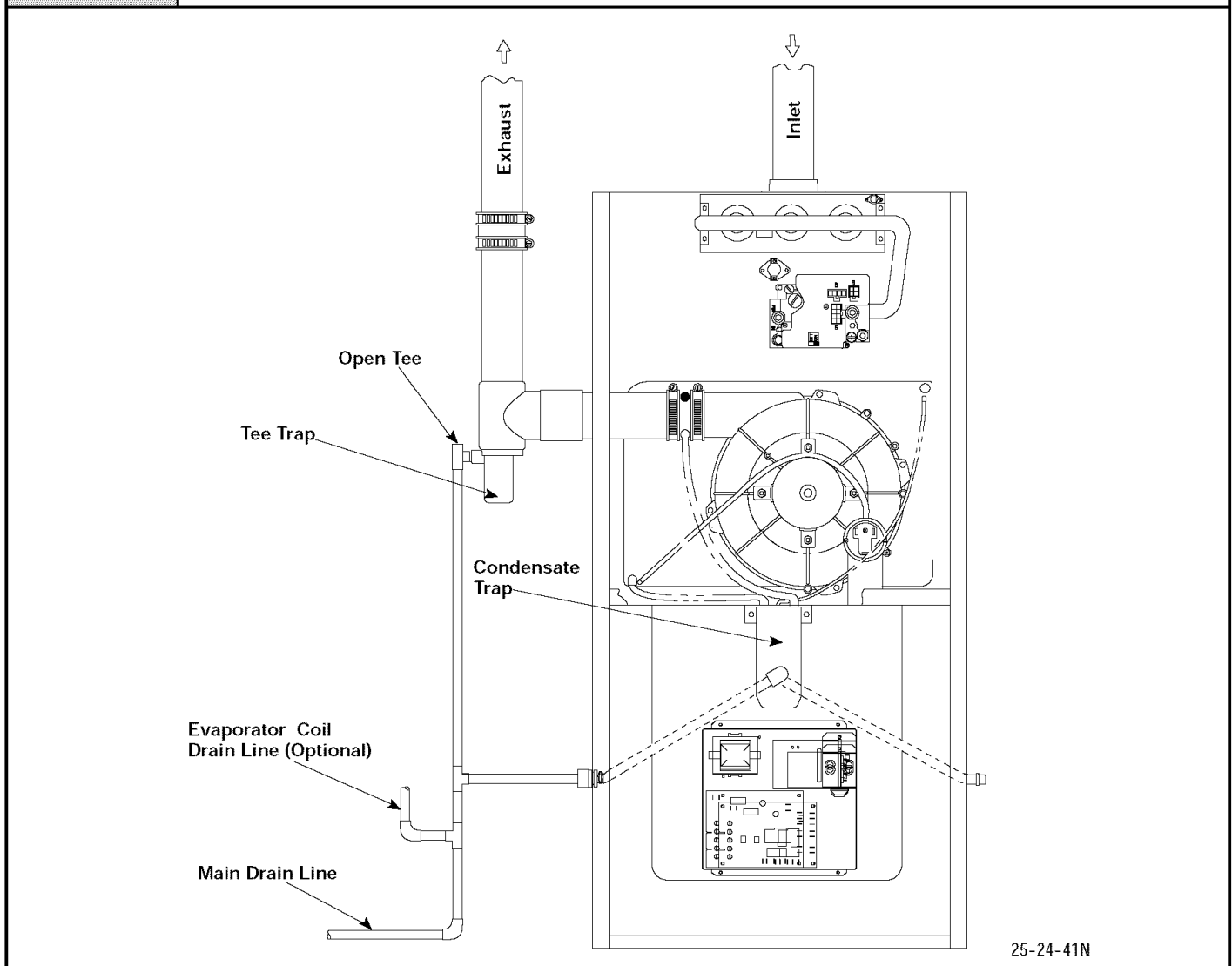

The Tee Trap must be connected to the main condensate drain line as conceptually shown above. Different installations may require slightly different orientations. The following steps apply to all installations.

1. The Tee Trap should be installed as close to the side or top of the furnace as practical. Minimize the distance between the inducer and the Tee Trap as much as possible.
2. An open tee is to be used at the Tee Trap discharge. The top end of the tee should be open to the atmosphere to eliminate potential air lock problems.
3. The drain line from the Tee Trap is to be connected to the furnace condensate trap drain line as shown above.
4. Condensate drain lines from a cooling coil may be connected downstream of the connection point of the Tee Trap and Furnace Condensate Trap.

Important: Prime both traps with water before operation. Failure to prime the traps may result in discharge of flue gases from the condensate drain line and open tee for a period of time, and may result in temporary lockout of the furnace upon start up. Main drain line construction is left to the discretion of the installer. It may be made of either ridged pipe or flexible tube. Tube ID should NOT be less than $\frac{1}{2}$ ".

Connecting Vent and Combustion Air Piping

⚠ WARNING

CARBON MONOXIDE POISONING HAZARD

Failure to properly seal vent piping could result in death, personal injury and/or property damage.

Cement or mechanically seal all joints, fittings, etc. to prevent leakage of flue gases.

Refer to **Figure 9** through **Figure 17** that corresponds to the installation position of the furnace for the application.

Preassemble the vent and combustion air piping from the furnace to the vent termination. Do not cement the pipe joints until the pipe preassembly process is complete.

Combustion Air Pipe Connection (Dual Certified or Direct Vent)

Install the air intake coupling and gasket to the furnace with the four(4) screws.

Note: The air intake coupling and gasket can be installed to the top panel to the alternate air intake locations on either the left or right side panels of the furnace.

25-24-41N

For downflow installation, the air intake coupling and gasket must be installed to the alternate air intake location on either the left or right side panels. Remove the 3" hole plug from the side panel and relocate to the air intake hole in the top panel. Use four screws to seal the four(4) mounting holes in the top panel next to the hole plug. Drill four(4) $\frac{7}{16}$ " diameter holes in the casing using the air intake coupling as the template.

The air intake coupling is sized for 2" PVC pipe.

Install the combustion air pipe to the air intake coupling using RTV sealant to provide for future serviceability.

Vent Pipe Connection

Install the vent pipe grommet to the furnace panel. Locate the grommet in the furnace panel at a location directly away from the vent fitting on the combustion blower. The grommet snaps into the 3" hole plug from the furnace panel. NOTE: Depending on the installation position, the vent pipe grommet will be installed to the top panel or to the alternate location on the side panels. If needed, remove the 3" hole plug from the furnace panel and relocate to the open hole in the furnace panel. (See **Figure 9** or **Figure 18**)

Install the vent pipe to the rubber coupling, the vent fitting or the PVC vent extension pipe. Securely attach using the clamp or PVC cement as required.

Note: The vent fitting **MUST** be installed with the air flow marking arrow pointed toward the vent pipe. (See **Figure 19**) Some installations require the vent fitting to be installed with a 5° to 10° downward slope. (See **Figure 9** thru **Figure 18**)

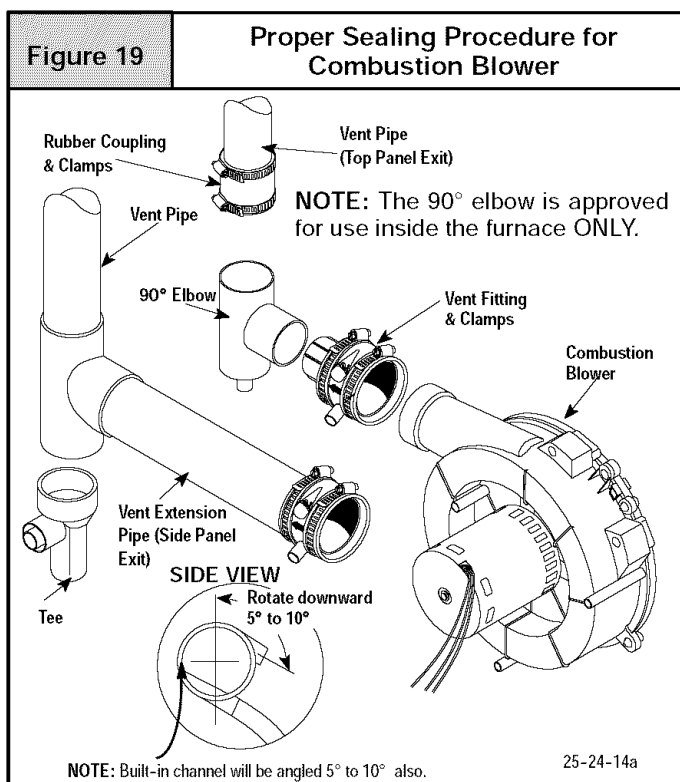

Joining Pipe and Fittings

⚠ WARNING

FIRE HAZARD

Failure to do so could result in personal injury and/or property damage.

Observe all cautions and warnings printed on material containers

Provide adequate ventilation and do **NOT** assemble near heat source or open flame. Do **NOT** smoke while using solvent cements and avoid contact with skin or eyes.

This furnace is approved for venting with Schedule 40 PVC, CPVC, ABS, Cellular Core pipe fittings and SDR-26 PVC.

NOTE: All PVC, CPVC, ABS, and Cellular Core pipe fittings, solvent cement, primers and procedures **MUST** conform to American National Standard Institute and American Society for Testing and Materials (ANSI/ASTM) standards.

- *Pipe and Fittings* – ASTM D1785, D2241, D2466, D2661, D2665, F-891, F-628
- *PVC Primer and Solvent Cement* – ASTM D2564
- *Procedure for Cementing Joints* – Ref ASTM D2855

NOTE: In order to create a seal that allows future removal of pipe, RTV sealant **MUST** be used on the inlet pipe where it joins to the furnace. PVC, CPVC, ABS, and Cellular Core pipe and cement may be used on all other joints.

⚠ WARNING

CARBON MONOXIDE POISONING HAZARD

Failure to follow this warning could result in personal property damage, injury or death.

Do **NOT** use solvent cement that has become curdled, lumpy or thickened and do **NOT** thin. Observe precautions printed on containers. For applications below 32° F., use only low temperature type solvent cement. Poor joints may lead to disconnected or leaking vent pipe joints allowing carbon monoxide to enter the living space.

1. Cut pipe end square, remove ragged edges and burrs. Chamfer end of pipe, then clean fitting, socket and pipe joint of all dirt, grease, or moisture.

NOTE: Stir the solvent cement frequently while using. Use a natural bristle brush or the dauber supplied with the cement. The proper brush size is one inch.

2. After checking pipe and socket for proper fit, wipe socket and pipe with cleaner-primer. Apply a liberal coat of primer to inside surface of socket and outside of pipe. Do **NOT** allow primer to dry before applying cement.
3. Apply a thin coat of cement evenly in the socket. Quickly apply a heavy coat of cement to the pipe end and insert pipe into fittings with a slight twisting movement until it bottoms out.

NOTE: Cement **MUST** be fluid while inserting pipe. If **NOT**, recoat pipe.

4. Hold the pipe in the fitting for 30 seconds to prevent the tapered socket from pushing the pipe out of the fitting.
5. Wipe any excess cement from the joint with a rag. Allow 15 minutes before handling. Cure time varies according to fit, temperature and humidity.

Connecting Vent Pipes and Termination

NOTE: Combustion air intake and vent **MUST** terminate in the same atmospheric pressure zone. If installation is in a cold climate (sustained temperatures below 0° F), increase the minimum distance between vent pipe and air intake from 8" to 18".



WARNING

CARBON MONOXIDE POISONING HAZARD.

Failure to properly vent this furnace could result in death, personal injury and/or property damage.

Maintain a minimum of 36" between combustion air inlet and clothes dryer vent. Terminate the combustion air intake as far as possible from any air conditioner, heat pump, swimming pool, swimming pool pumping, chlorinator or filtration unit.

1. Install all couplings, nipples and elbows using proper procedures for **Joining Pipe and Fittings** and maintain spacing between vent and combustion air piping as indicated in **Figure 20** through **Figure 27**.

Figure 20

Sidewall Termination 12" or More Above Snow Level or Grade Level

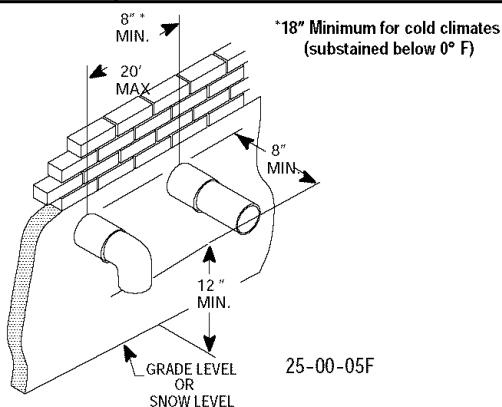

25-00-05F

Horizontal Termination

1. Cut two holes. 2¹/₂" for 2" pipe, 3" for 2¹/₂" pipe, or 3¹/₂" for 3" pipe. Do **NOT** make the holes oversized, or it will be necessary to add a sheet metal or plywood plate on the outside with the correct size hole in it.
2. Check hole sizes by making sure it is smaller than the couplings or elbows that will be installed on the outside. The couplings or elbows **MUST** prevent the pipe from being pushed back through the wall.
3. Extend vent pipe and combustion air pipe through the wall ³/₄" to 1" and seal area between pipe and wall.
4. Install the couplings, nipple and termination elbows as shown and maintain spacing between vent and combustion air piping as indicated in **Figure 20** and **Figure 21**.

A metal shield is recommended 18" x 18" min. or 18" min. diameter around the vent termination at the exterior wall to protect the house exterior materials from flue product or condensation (freezing) damage.

Using Exterior Risers

1. Install elbows and pipe to form riser as shown in **Figure 21**.

2. Secure vent pipe to wall with galvanized strap or other rust resistant material to restrain pipe from moving.
3. Insulate pipe with Armaflex or equivalent moisture resistant closed cell foam insulation or Fiberglass insulation if boxed in and sealed against moisture.

Figure 21

Sidewall Termination with Exterior Risers to Get Above Snow Level or Grade Level

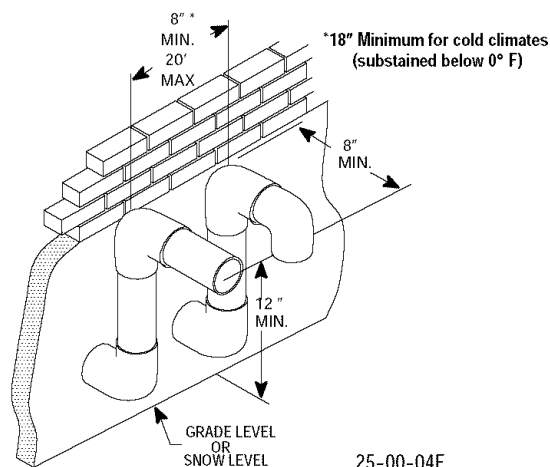

25-00-04F

Vertical Termination

1. **Figure 22** shows the proper installation and clearances for vertical vent termination. The vertical roof termination should be sealed with a plumbing roof boot or equivalent flashing. The inlet of the intake pipe and end of the exhaust vent must be terminated no less than 12" above the roof or snow accumulation level, and 12" away from a vertical wall or other protrusion.
2. If the vent system is installed in an existing chimney make sure clearances shown in **Figure 22** are maintained. Horizontal section before the termination elbow can be extended on the inlet air to provide necessary clearance.

Figure 22

Rooftop Termination

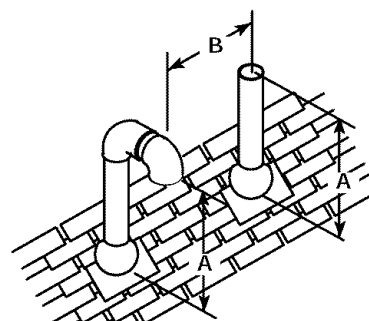

A = 12" Above roof or snow accumulation level
B = 8" Min., 20" Maximum, except in areas with extreme cold temperatures (sustained below 0°F), the 18" Min.

Vent Termination Shielding

Under certain wind conditions some building materials may be affected by flue products expelled in close proximity to unprotected surfaces. Sealing or shielding of the exposed surfaces with a corrosion resistant material (such as aluminum sheeting) may be required to prevent staining or deterioration. The protective material should be attached and sealed (if necessary) to the building before attaching the vent terminal.

Multi Vent Termination Clearances

When two (2) or more furnaces are vented near each other, each furnace must be individually vented.

Two (2) vent terminations may be installed as shown in **Figure 23**, **Figure 24**, **Figure 25**, **Figure 26**, **Figure 27** and **Figure 28**, but the next vent termination must be at least 36" away from first 2 terminations. It is important that vent terminations be made as shown to avoid recirculation of flue gases.

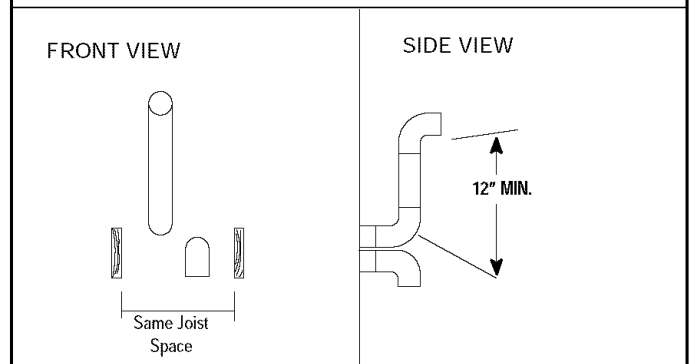
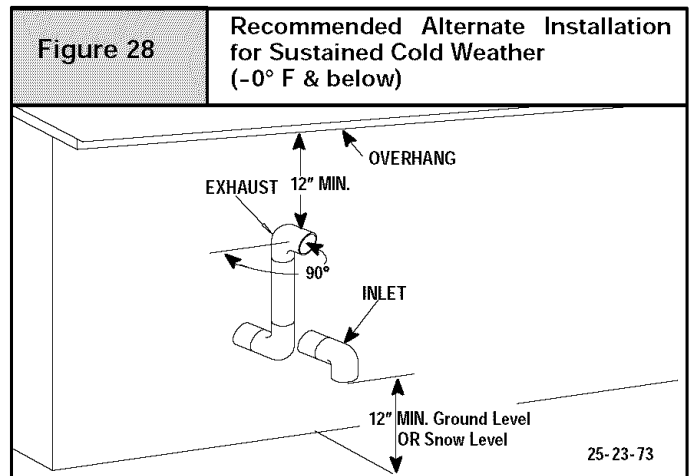
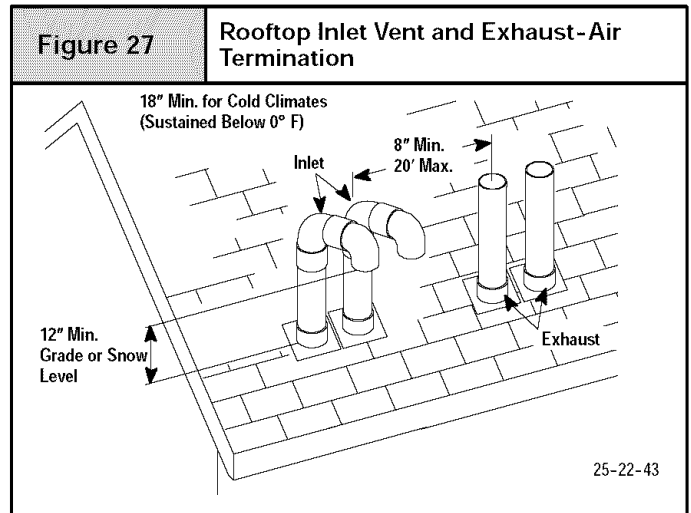
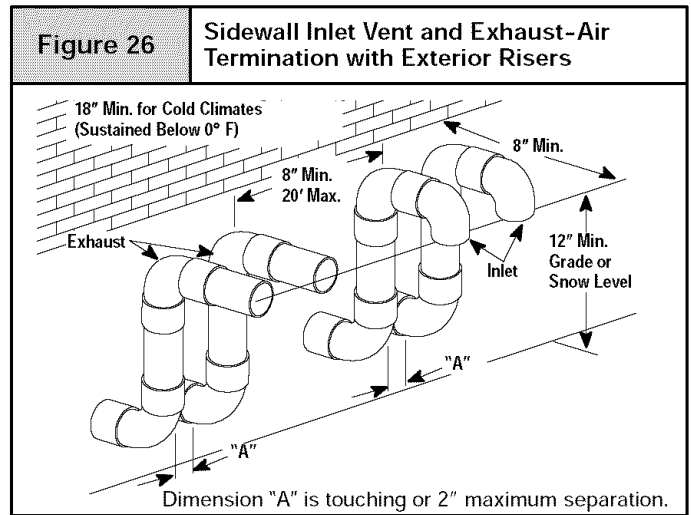
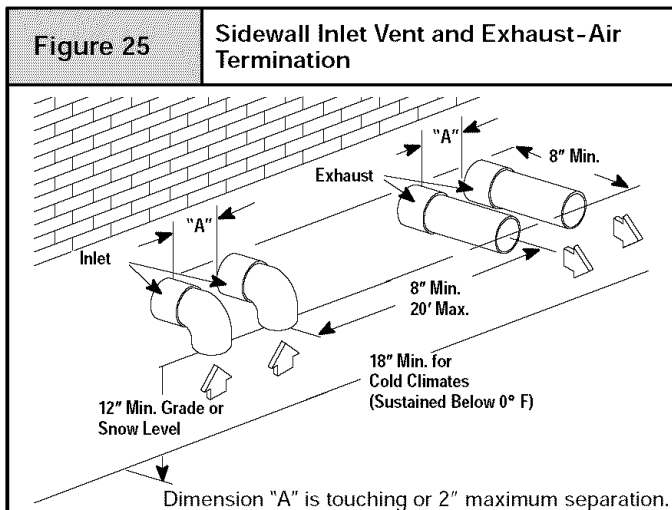
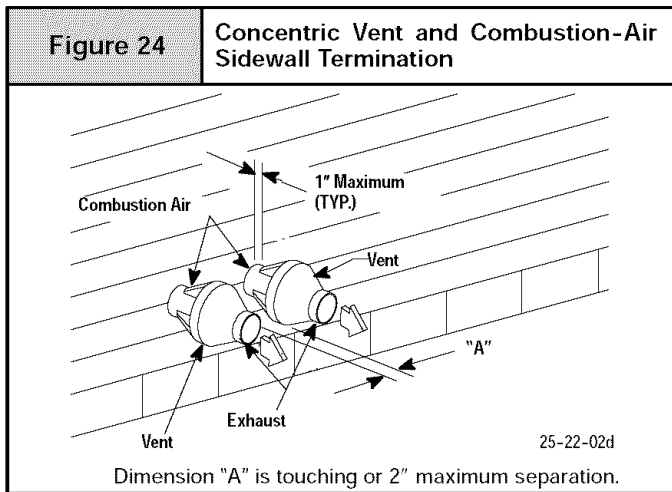
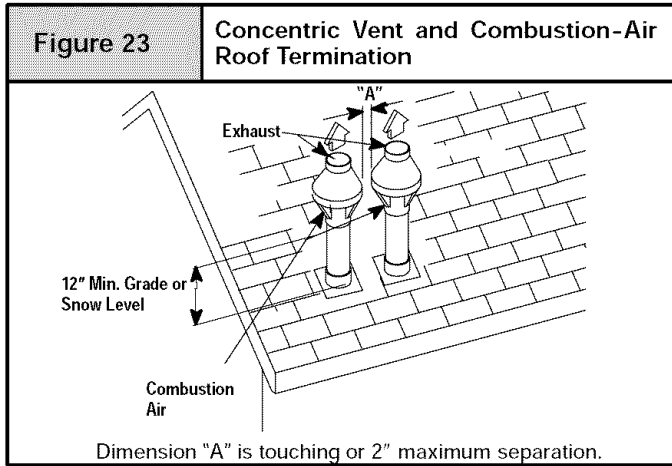

5. Gas Supply and Piping

⚠ WARNING

CARBON MONOXIDE POISONING, FIRE AND EXPLOSION HAZARD.

Failure to follow these instructions could result in death, personal injury and/or property damage.

Models designated for Natural Gas are to be used with Natural Gas **ONLY**, unless properly converted to use with LP gas.

NOTE: The rating plate is stamped with the model number, gas type and gas input rating. In addition, models manufactured for sale in Canada have orifice size information stamped on the rating plate.

Supply Pressure

⚠ WARNING

FIRE HAZARD.

Failure to properly set input pressure could result in death, personal injury and/or property damage.

Do **NOT** set input rating above that shown on rating plate.

1. Supply pressure can be checked using the $\frac{1}{8}$ " NPT port on the supply side of the gas valve.
2. Gas input to burners **MUST NOT** exceed the rated input shown on rating plate.
3. Do **NOT** allow minimum gas supply pressure to vary downward. Doing so will decrease input to furnace. Refer to **Table 6** or **Table 7** for normal gas supply and manifold pressures.

Gas Supply Pressure

⚠ WARNING

FIRE HAZARD

Failure to properly set input pressure could result in death, personal injury and/or property damage.

Do **NOT** set input rating above that shown on rating plate.

Gas supply pressure should be within minimum and maximum values listed on rating plate. Pressures are usually set by gas suppliers.

Manifold Gas Pressure Adjustment (Hi & Lo Fire)

NOTE: Make adjustment to manifold pressure with burners operating.

⚠ WARNING

ELECTRICAL SHOCK HAZARD.

Failure to do so could result in death, personal injury and/or property damage.

Turn **OFF** power to furnace before changing speed taps.

1. Remove the burner compartment door.
2. Return fourth (4th) DIP switch to previous setting.
3. Replace the burner compartment door.

General Derating Rules

1. These furnaces may be used at full input rating when installed at altitudes up to 2,000'. When installed above 2,000', the input must be decreased 2% (natural) or 4% (LP) for each 1000' above sea level. See **Table 5** for required high altitude input rate.

Table 5		
High Altitude Input Rate = Nameplate Sea Level Input Rate x (Multiplier)		
Elevation	High Altitude Multiplier	
	Natural Gas	LP Gas
2001' - 3000'	0.95	0.90
3001' - 4000'	0.93	0.86
4001' - 5000'	0.91	0.82
5001' - 6000'	0.89	0.78
6001' - 7000'	0.87	0.74
7001' - 8000'	0.85	0.70

* Based on mid-range of elevation.

2. For operation with natural gas at altitudes above 2,000', orifice change and/or manifold pressure adjustment may be required for the gas supplied. First consult your local gas supplier, then refer to **Table 6** for required pressure change and/or orifice change for high altitudes.
3. For operation with LP gas, gas orifices **MUST** be changed and manifold pressure **MUST** be *maintained* as per **Table 7**. Orifices can be ordered through your distributor. (See **Figure 29**)

High Altitude Air Pressure Switch

Altitudes over 4,000' may require a different air pressure switch than the one installed at the factory. Check parts list for pressure switch and consult your distributor for part number and availability. In Canada, provincial codes may govern installation of switch. Check with governing authorities.

NOTE: The derating of these units at 2% (Natural) and 4% (L.P.) has been tested and approved by CSA.

MANIFOLD PRESSURE AND ORIFICE SIZE FOR HIGH ALTITUDE APPLICATIONS

Table 6	NATURAL GAS MANIFOLD PRESSURE (" w.c.)																				
	MEAN ELEVATION FEET ABOVE SEA LEVEL																				
	0 to 2000			2001 to 3000			3001 to 4000			4001 to 5000			5001 to 6000			6001 to 7000			7001 to 8000		
	Orifice No.	Mnfl'd Pressure		Orifice No.	Mnfl'd Pressure		Orifice No.	Mnfl'd Pressure		Orifice No.	Mnfl'd Pressure		Orifice No.	Mnfl'd Pressure		Orifice No.	Mnfl'd Pressure		Orifice No.	Mnfl'd Pressure	
Hi		Lo	Hi		Lo	Hi		Lo	Hi		Lo	Hi		Lo	Hi		Lo	Hi		Lo	
700	--	--	--	--	--	--	--	--	--	--	--	--	--	--	--	--	--	41	3.7	1.8	
725	--	--	--	--	--	--	--	--	--	--	--	--	--	--	41	3.7	1.8	41	3.4	1.7	
750	--	--	--	--	--	--	--	--	--	--	--	--	--	--	41	3.5	1.7	42	3.6	1.7	
775	--	--	--	--	--	--	--	--	--	--	--	--	41	3.6	1.7	42	3.6	1.8	42	3.3	1.6
800	--	--	--	--	--	--	--	--	--	41	3.6	1.8	42	3.7	1.8	42	3.4	1.7	42	3.1	1.5
825	--	--	--	--	--	--	41	3.7	1.8	41	3.4	1.7	42	3.5	1.7	42	3.2	1.6	42	2.9	1.4
850	--	--	--	--	--	--	41	3.5	1.7	42	3.6	1.7	42	3.3	1.6	42	3.0	1.5	42	2.8	1.4
875	--	--	--	41	3.6	1.7	42	3.6	1.8	42	3.4	1.6	42	3.1	1.5	42	2.8	1.4	42	2.6	1.3
900	--	--	--	42	3.7	1.8	42	3.4	1.7	42	3.2	1.6	42	2.9	1.4	42	2.7	1.3	42	2.5	1.2
925	41	3.7	1.8	42	3.5	1.7	42	3.3	1.6	42	3.0	1.5	42	2.8	1.4	42	2.5	1.2	42	2.3	1.1
950	41	3.5	1.7	42	3.3	1.6	42	3.1	1.5	42	2.9	1.4	42	2.6	1.3	42	2.4	1.2	43	2.7	1.3
975	42	3.7	1.8	42	3.2	1.6	42	2.9	1.4	42	2.7	1.3	42	2.5	1.2	42	2.3	1.1	43	2.6	1.3
1000	42	3.5	1.7	42	3.0	1.5	42	2.8	1.4	42	2.6	1.3	42	2.4	1.2	43	2.7	1.3	43	2.4	1.2
1050	42	3.2	1.6	42	2.7	1.3	42	2.5	1.2	42	2.3	1.1	43	2.6	1.3	--	--	--	--	--	--
1100	42	2.9	1.4	42	2.5	1.2	42	2.3	1.1	43	2.6	1.3	--	--	--	--	--	--	--	--	--

NOTE: Natural gas data is based on 0.60 specific gravity. For fuels with different specific gravity consult the National Fuel Gas Code ANSI Z223.1-2002/NFPA 54-2002 or National Standard of Canada, Natural Gas and Propane Installation Code CSA B149.1-00.

Table 7	LPG or PROPANE GAS MANIFOLD PRESSURE (" w.c.)													
	MEAN ELEVATION FEET ABOVE SEA LEVEL													
	0 to 2000		2001 to 3000		3001 to 3999		4001 to 5000		5001 to 6000		6001 to 7000		7001 to 8000	
	Hi	Lo	Hi	Lo	Hi	Lo	Hi	Lo	Hi	Lo	Hi	Lo	Hi	Lo
2500	10.0	4.9	10.0	4.9	9.0	4.4	10.0	4.9	9.4	4.6	8.5	4.2	10	4.9
Orifice Size	#54		#54		#54		#55		#55		#55		#56	

NOTE: Propane data is based on 1.53 specific gravity. For fuels with different specific gravity consult the National Fuel Gas Code ANSI Z223.1-2002/NFPA 54-2002 or National Standard of Canada, Natural Gas and Propane Installation Code CSA B149.1-00.

NOTE: The derating of these furnaces at 2% (Natural Gas) and 4% (LP Gas) has been tested and design-certified by CSA.

4. Tighten orifices so it is seated and gas tight. (See Figure 29)

Changing Orifices for High Altitude

⚠ WARNING

ELECTRICAL SHOCK, FIRE OR EXPLOSION HAZARD.

Failure to properly install orifices could result in death, personal injury and/or property damage.

Turn OFF electric power (at disconnect) and gas supply (at manual valve in gas line) when installing orifices. Installation of orifices requires a qualified service technician.

NOTE: Main burner orifices can be changed for high altitudes.

1. Disconnect gas line from gas valve.
2. Remove manifold from furnace.
3. Remove the orifices from the manifold and replace them with properly sized orifices.

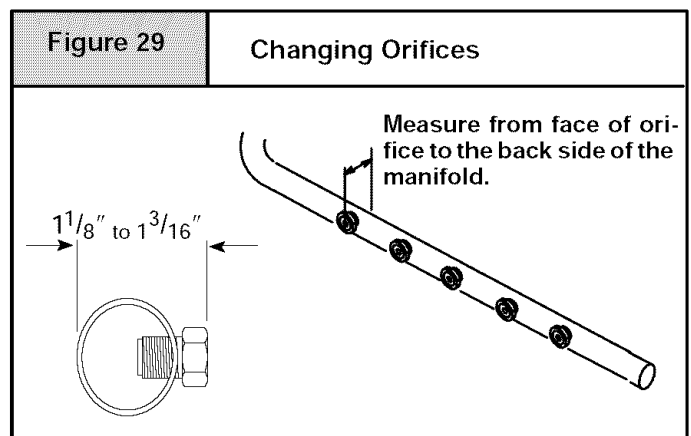

5. Reinstall manifold. Ensure burners do NOT bind on new orifices.

Figure 30

Typical Gas Piping for Upflow

Drip Leg and Union, Union* should be outside the cabinet. Manual shut-off valve MUST be upstream of dripleg, union, and furnace.

Use elbows and 3" pipe nipple to connect valve to piping when using right side gas pipe entry.

LP Low pressure switch. Optional on some models.

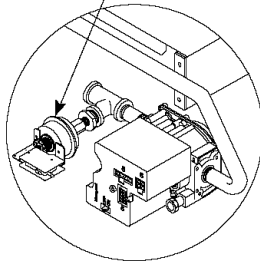

3" pipe nipple

Gas Pipe Grommet (Single Pipe)

Manual shut-off valve

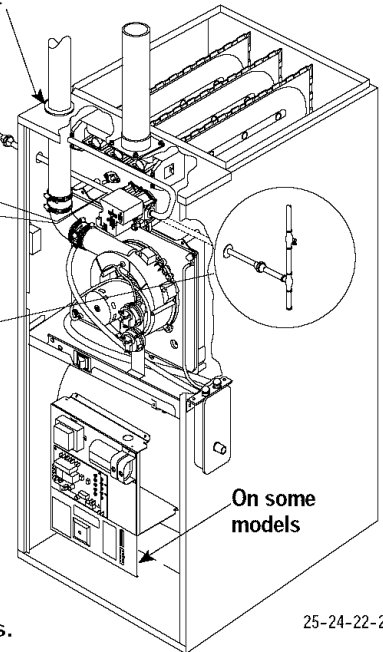
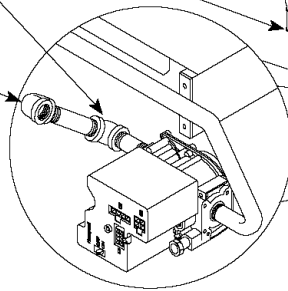

On some models

* Union may be installed inside the cabinet when necessary because of clearances.

25-24-22-2

Natural Gas Input Rating Check

NOTE: The gas meter can be used to measure input to furnace. Rating is based on a natural gas BTU content of 1,000 BTU's per cubic meter. Check with gas supplier for actual BTU content.

1. Turn OFF gas supply to all appliances and start furnace. Use jumper wire on R to W1 and W2 for Hi fire.
2. Time how many seconds it takes the smallest dial on the gas meter to make one complete revolution. Refer to **Example**.
3. Repeat steps 1 and 2 with jumper wire on R to W2 for low fire.

NOTE: Fourth (4th) dip switch must be in "ON" position. (See Furnace Wiring Diagram). Return fourth (4th) dip switch to previous setting after check.

Example			
Natural Gas BTU Content	No. of Seconds Per Hour	Time Per Cubic Foot in Seconds	BTU Per Hour
1,000	3,600	48	75,000
$1,000 \times 3,600 \div 48 = 75,000 \text{ BTUH}$			

4. Relight all appliances and ensure all pilots are operating.
- NOTE: If meter uses a 2 cubic foot dial, divide results (seconds) by two.

Figure 31

Typical Gas Piping for Downflow

Use elbows and 3" pipe nipple to connect valve to piping when using left side gas pipe entry.

LP Low pressure switch. Optional LP conversion.

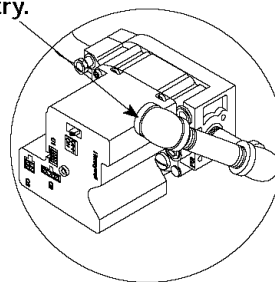
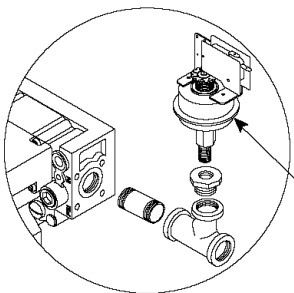

Drip Leg and Union, Union* should be outside the cabinet. Manual shut-off valve MUST be upstream of dripleg, union, and furnace.

Manual shut-off valve

Gas Pipe Grommet (Single Pipe)

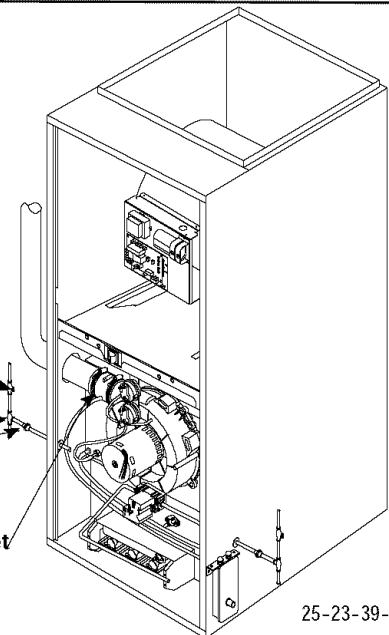

*Union may be installed inside the cabinet when necessary because of clearances.

25-23-39-4

Gas Piping Requirements

1. Properly size gas pipe to handle combined appliance load or run gas pipe directly from gas meter or LP gas regulator. Refer to NFGC and ANSI Z223.1 for proper gas pipe size.
2. Install correct pipe size for run length and furnace rating.
3. Measure pipe length from gas meter or LP second stage regulator.

NOTE: Refer to **Figure 30** or **Figure 31** for the general layout at the furnace. The rules listed apply to natural and LP gas pipe installations.

NOTE: On the Dual Certified or Direct Vent models, install the gas pipe grommet to the furnace side panel with the gas pipe entry. If needed, remove the 2" hole plug and relocate to the open hole in the furnace side panel.

⚠ WARNING

FIRE OR EXPLOSION HAZARD

Failure to properly install metal gas connector could result in death, bodily injury and/or property damage.

A flexible corrugated metal gas connector must be properly installed, shall not extend through the side of the furnace, and shall not be used inside the furnace.

Black iron pipe shall be installed at the furnace gas control valve and extend a minimum of 2" outside furnace casing.

6. Electrical Wiring

⚠ WARNING

ELECTRICAL SHOCK HAZARD.

Failure to do so could result in death, personal injury and/or property damage.

Turn OFF electrical power at fuse box or service panel before making any electrical connections and ensure a proper ground connection is made before connecting line voltage.

Power Supply Wiring

The furnace **MUST** be electrically wired and grounded in accordance with local codes, or in the absence of local codes with the latest edition of The National Electric Code, ANSI NFPA 70 and/or The Canadian Electric Code CSA C22.1.

Field wiring connections must be made inside the furnace connection box. A suitable strain relief should be used at the point the wires exit the furnace casing.

Copper conductors shall be used. Line voltage wires should conform to temperature limitation of 63° F (35° C) rise and be sized for the unit maximum amps stated on the rating plate. Add the full load amps for potential field-installed accessories such as electronic air cleaners and humidifiers that would receive power from the furnace control. The furnace control is rated for a maximum of 0.8 amps combined for EAC and Hum. Consult NEC or local codes for proper wire and circuit sizing.

4. Use black iron or steel pipe and fittings or other pipe approved by local code.
5. Use ground joint unions and install a drip leg no less than 3" long to trap dirt and moisture before it can enter gas valve.
6. Use two pipe wrenches when making connections to prevent gas valve from turning.
7. Install a manual shut-off valve external to furnace casing and tighten all joints securely.

Additional LP Connection Requirements

1. Have a licensed LP gas dealer make all connections at storage tank and check all connections from tank to furnace.
2. If copper tubing is used, it **MUST** comply with limitation set in National Fuel Gas Code or CGA codes.
3. Two-stage regulation of LP gas is recommended.

Final Check

1. The furnace and the gas valve must be disconnected from the gas supply piping system during any pressure testing of that system at test pressures in excess of 1/2" PSIG. Close the manual shut-off valve before testing at such pressures.
2. When installation is complete, test all pipe connections for leaks with the gas pressure less than 1/2" PSIG to the gas valve.
3. Apply a commercial soap solution to all joints to test for leaks. Correct any leaks indicated by bubbles.
4. Correct even the smallest leak at once.
5. Check for leaks at gas valve and orifice connections to the burner manifold along with the pilot tube connections to the valve and pilot assembly while the furnace is operating.

J-Box Relocation

The j-box is installed on left side of casing. An alternate j-box location on right side can be used.

1. Remove bag containing two hole plugs and two self tapping screws from loose parts bag in blower compartment.
2. Remove two screws holding j-box to casing.
3. Move large hole plug from right to left j-box location.
4. Move j-box to alternate location and attach using two self tapping screws from bag.
5. Apply two hole plugs from bag at left j-box location.

Thermostat

The 2-stage furnace control will operate with either a single stage or a two stage heating thermostat and will provide 2-stage heating operation. For single stage thermostat installations, the **R** and **W** wires from the thermostat connect to the **R** and **W1** connections on the furnace control. **Note:** The fourth (4th) DIP switch must be in the off position, failure to change DIP switch will result in Lo Fire ONLY operation. (See furnace wiring diagram) See "Furnace Wiring Diagram" for switch settings. Failure to set DIP switch will result in Lo fire operation ONLY with single stage thermostat. During operation, the furnace will operate on low fire for 12 minutes. If the heat request exists for more than 12 minutes, the furnace will automatically shift to the high fire mode for the remaining duration of the heating cycle. For two stage thermostat installations, the **R**, **W1** and **W2** wires from the thermostat connect to the **R**, **W1** and **W2** connections on the furnace control. During operation, the furnace will shift from low fire to high fire as requested by the thermostat. The thermostat heat anticipators should be adjusted to a .10 setting for both types of thermostats.

Low voltage connections to furnace must be made on terminal board to fan control.

Optional Equipment

All wiring from furnace to optional equipment **MUST** conform to local codes or, in the absence of local codes with the latest edition of The National Electric Code, ANSI NFPA 70 and/or The Canadian Electric Code CSA C22.1. Install wiring in accordance with manufacturer's instructions. The wiring **MUST** have a minimum temperature rating of 105° C. codes or, in the absence of local codes, the applicable national codes. Install wiring in accordance with manufacturer's instructions.

Humidifier/Electronic Air Cleaner

The furnace is wired for humidifier and/or electronic air cleaner connection.

⚠ CAUTION

REDUCED FURNACE LIFE HAZARD

Failure to follow caution instructions may result in reduced furnace life.

Do **NOT** exceed 115V/0.8 amp. maximum current load for both the EAC terminal and the HUM terminal combined.

NOTE: The humidifier will be powered when the furnace is fired and the circulating air blower comes on. The electronic air cleaner will be powered anytime the air circulating blower is energized. However, the electronic air cleaner is **NOT** energized during continuous fan operation controlled by the electronic fan control.

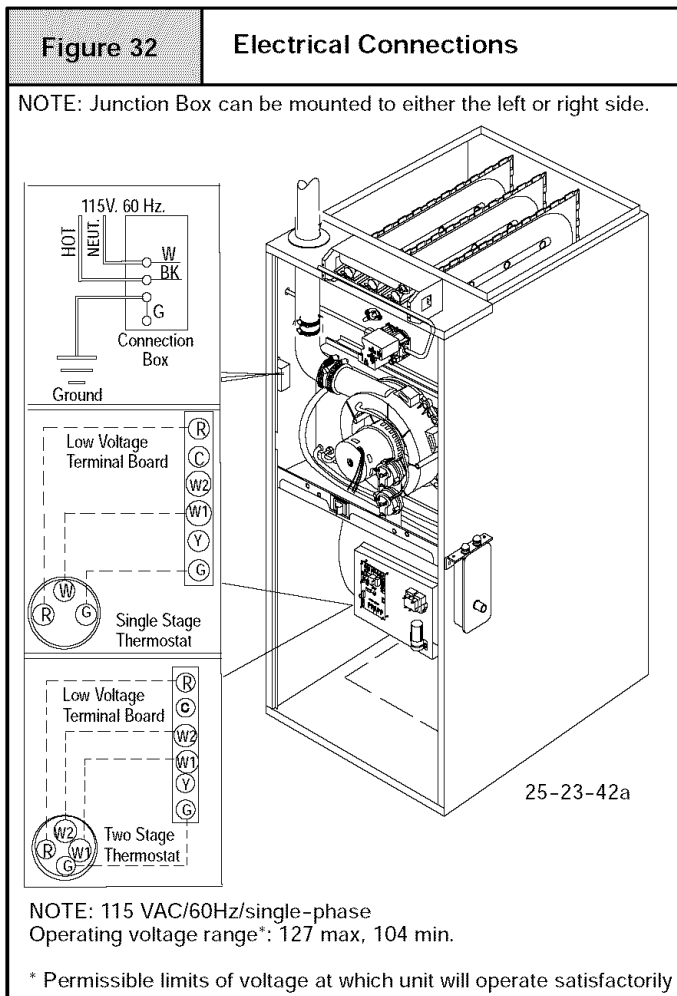

Fan Control

The fan control is preset at the factory with a fixed blower **ON** delay of 30 seconds in the heating mode. The blower **OFF** timing is preset at 140 seconds. If desired, the fan **OFF** delay can be reset to obtain the longest delay times while still maintaining comfort levels. See "Furnace Wiring Diagram".

Dehumidification - Variable Speed ONLY (*9MPV)

The fan control is wired for 24 VAC normally-open (N/O) dehumidistat connection. Connect dehumidistat to the Y terminal and the 1/4" male quick connect Y2 terminal on the fan control (See **Figure 33** and "Furnace Wiring Diagram".) A 20% reduction of cooling airflow will occur when the Y2 dehumidistat terminal is energized by being connected to Y during a call for cooling from the thermostat.

Control Center Fuse

The 24V circuit contains a 5-amp, automotive-type fuse located on fan timer board. (See **Figure 33**) Any electrical shorts of 24V wiring during installation, service, or maintenance may cause fuse to blow. If fuse replacement is required, use only a fuse of identical size (5 amp.)

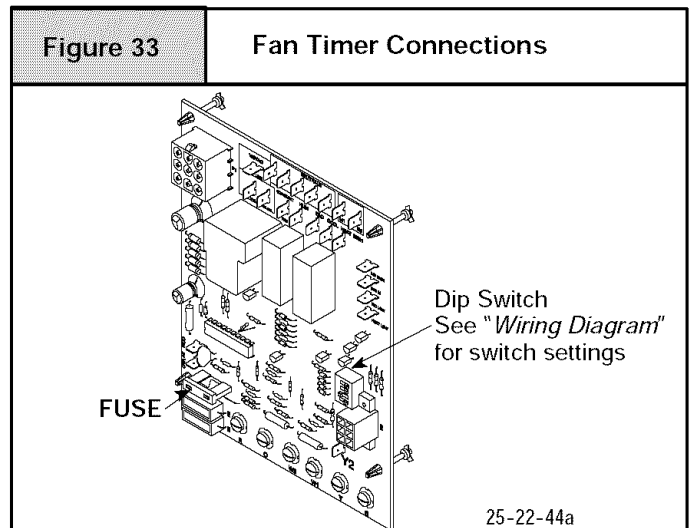

7. Ductwork and Filter



WARNING

CARBON MONOXIDE POISONING HAZARD.

Failure to properly seal duct could result in death, personal injury and/or property damage.

Do NOT draw return air from inside a closet or utility room. Return air duct MUST be sealed to furnace casing.

Installation

NOTE: Design and install air distribution system to comply with Air Conditioning Contractors of America manuals and/or NFPA pamphlets 90A and 90B or other approved methods that conform to local codes and good trade practices.

1. When furnace supply ducts carry air outside furnace area, seal return air duct to furnace casing and terminate duct outside furnace space .
2. Install air conditioning cooling coil (evaporator) on outlet side of furnace.
3. For furnaces installed without a cooling coil it is recommended that the outlet duct be provided with a removable access panel. This panel should be accessible when the furnace is installed so the exterior of the heat exchanger can be viewed for inspections. The access panel **MUST** be sealed to prevent leaks.
4. If separate evaporator and blower units are used, install good sealing dampers for air flow control. Chilled air going through the furnace could cause condensation and shorten the furnace life.

NOTE: Dampers (field supplied) can be either automatic or manual. Manually operated dampers **MUST** be equipped with a means to prevent furnace or air conditioning operation unless damper is in the full heat or cool position.



WARNING

CARBON MONOXIDE POISONING HAZARD.

Failure to follow this warning could result in death, personal injury and/or property damage.

Cool air passing over heat exchanger can cause condensate to form resulting in heat exchanger failure.

Connections

NOTE: On upflow installations, return air can enter through either side, both sides, or the bottom. On horizontal or downflow installations the return air must enter through the knockout opening in the lower panel of the furnace. Return air **cannot** enter through rear of the furnace. When the furnace is located in an area near or adjacent to the living area, the system should be carefully designed with returns to minimize noise transmission through the return grille. Any blower moving a high volume of air will produce audible noise which could be objectionable to when the unit is located very close to living areas. It is advisable to route the return air ducts under the floor or through the attic.

1. For side connections using a 16" x 25" filter, cut out the embossed area shown in **Figure 34**. This will provide a 14¹/₂" x 22¹/₂" approximate opening.

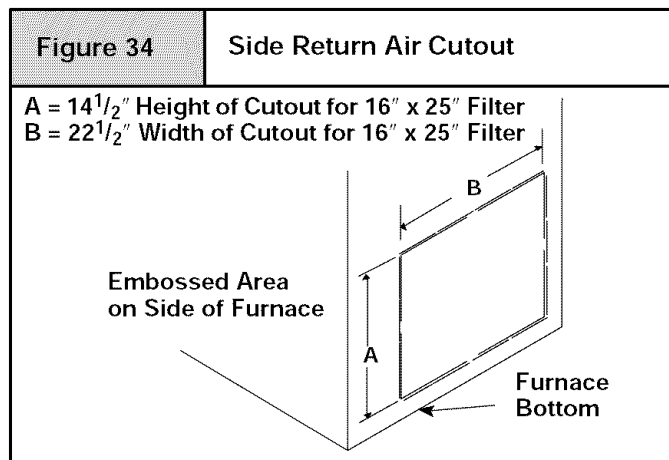

NOTE: Furnaces with 5 TONS cooling rating **require** two(2) side returns or one side return with bottom return.

2. Bottom returns can be made by removing the knockout panel in the furnace base. Do **NOT** remove knock-out except for a bottom return.
3. Installation of locking-type dampers are recommended in all branches, or in individual ducts to balance system's air flow.
4. Non-combustible, flexible duct connectors are recommended for return and supply connections to furnace.
5. If air return grille is located close to the fan inlet, install at least one, 90° air turn between fan and inlet grille to reduce noise.

NOTE: To further reduce noise, install acoustical air turning vanes and/or line the inside of duct with acoustical material.

Sizing

Existing or new ductwork **MUST** be sized to handle the correct amount of airflow for either heating only or heating and air conditioning.

Insulation

1. Insulate ductwork installed in attics or other areas exposed to outside temperatures with a minimum of 2" insulation and vapor barrier.
2. Insulate ductwork in indoor unconditioned areas with a minimum of 1" insulation with indoor type vapor barrier.

Filters

A Filter **must** be used:

Filters are not supplied with these furnaces, but can be purchased from dealer.

Use either filter type:

- Washable, high velocity filters are based on a maximum air flow rating of 600 FPM.
- Disposable, low velocity filters are based on a maximum air flow of 300 FPM when used with filter grille.

NOTE: Disposable, low velocity filters may be replaced with washable, high velocity filter providing they meet the minimum size areas. Washable, high velocity filters can be replaced **ONLY** with same type and size.

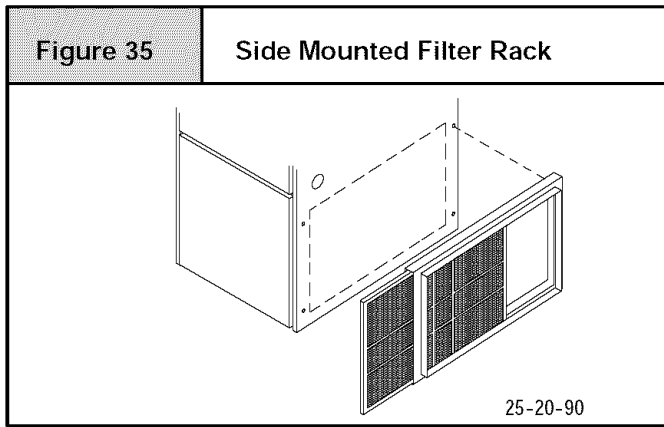

Filter Installation using Filter Rack

When installing or removing a bottom mounted filter, slide the two side filter clips to the back of the furnace **BEFORE** installing or removing. This will allow the filter to clear the front raised edge of the furnace. Insert filter into side clips first and push filter back until it is fully engaged into back clip. When filter is in place, slide clips back into place midway on filter as shown in **Figure 36**.

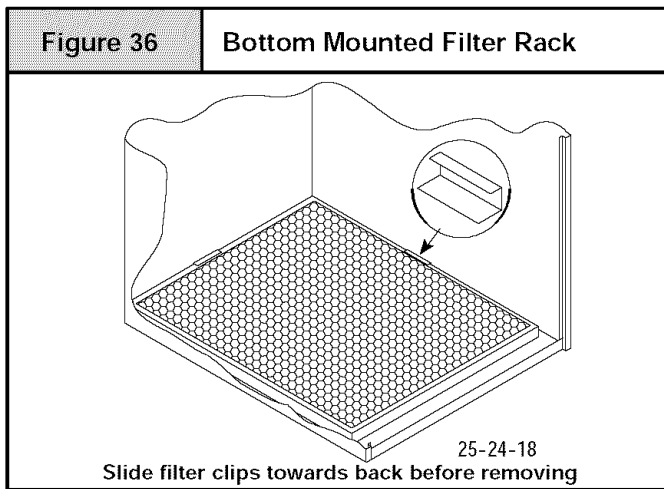

Refer to **Figure 37** and for guidelines to install filters. Furnaces which require larger filter media and have limited clearances on one side of furnace, require a standoff filter rack, see **Figure 37**, available from your distributor.

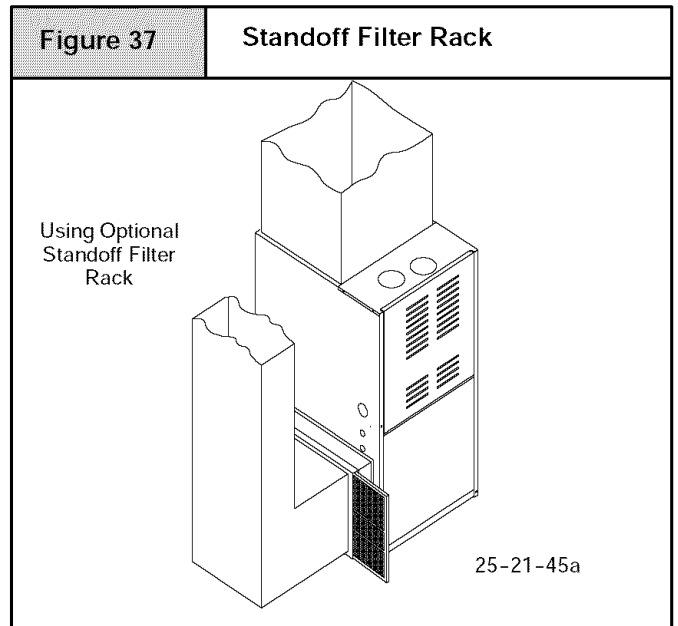

CAUTION

If filters are only suitable for heating application, advise homeowner that filter size may need to be increased if air conditioning is added.

Addition Of Air Conditioning

When a refrigeration coil is used in conjunction with this unit, it must be installed on the discharge side of the unit to avoid condensation on the heat exchanger. The coil installation instructions must be consulted for proper coil location and installation procedures. With a parallel flow arrangement, dampers must be installed to prevent chilled air from entering the furnace. If manually operated dampers are used, they must be equipped with a means to prevent operation of either unit unless the damper is in full heat or full cool position.

A 3" clearance is required on the right side of the furnace in order to run the condensate drain line. Copper, iron or plastic tubing may be used for the condensate drain line.

Downflow Furnace Installation

Non-Combustible Floor Installation

Fabricate a plenum to the dimensions given in **Figure 3**, for the furnace outlet. Plenum should be flanged, approximately $\frac{3}{4}$ " for support.

Note: The three(3) screws in the top panel of the furnace next to the duct flange **MUST** be removed to provide serviceability of the primary heat exchangers in the downflow installation

1. Position plenum through the floor and set the furnace over the opening in the floor. If necessary, grout around the base to seal air leaks between the base and the floor.

Combustible Floor Installation

 <h2 style="margin: 0;">WARNING</h2>
<p>FIRE HAZARD.</p> <p>Failure to install unit on noncombustible subbase could result in death, personal injury and/or property damage.</p> <p>Place furnace on noncombustible subbase on downflow applications, unless installing on non-combustible flooring.</p>

Subbase for Combustible Floor

NOTE: The three(3) screws in the top panel of the furnace next to the duct flange **MUST** be removed to provide serviceability of the primary heat exchangers in the downflow installation

Note: When using the subbase for combustible floors, the discharge air duct flanges on the furnace **MUST** be broken down to provide proper fit up to the subbase. Use duct pliers to bend the duct flanges flat onto the furnace casing. **DO NOT** bend the duct flanges inward (toward the heat exchangers) as air flow restrictions may occur.

The Subbase for Combustible Floors **MUST** be used when a downflow furnace is set on a combustible floor, even when the furnace is installed on a coil box.

1. Cut the opening in the floor according to **Table 8**. The hole in the floor must be cut to the dimensions listed in **Table 8** since the base is equipped with locating tabs that center the base over the opening.

The opening in the base is $1\frac{1}{4}$ " shorter and $1\frac{1}{8}$ " narrower than the recommended size of the opening in the floor. This is done to maintain clearance between the floor and the plenum.

2. Fabricate the plenum to the dimensions given in **Table 8**. Note that the dimensions given are outside dimensions.

Table 8		Subbases for Combustible Floors Dimensions									
Subbase for Combustible Floors Part Number	Subbase for Combustible Floor Dimensions				Opening In Floor		Opening In Base For Plenum		Typical Plenum Dimensions		
	H*	J*	K**	L	M	N	P	R	S	T	
Furnace Subbase											
NAHH001SB	15 ¹¹ / ₁₆	28 ³ / ₄	14 ⁹ / ₁₆	16	16 ¹ / ₄	14 ⁵ / ₈	15	13 ¹ / ₂	15	13 ¹ / ₂	
NAHH002SB	19 ⁵ / ₁₆	28 ³ / ₄	18 ³ / ₁₆	16	16 ¹ / ₄	18 ¹ / ₄	15	17 ¹ / ₈	15	17 ¹ / ₈	
NAHH003SB	22 ⁵ / ₁₆	28 ³ / ₄	21 ¹³ / ₁₆	16	16 ¹ / ₄	21 ¹ / ₈	15	19 ³ / ₄	15	19 ³ / ₄	
NAHH010SB	24 ¹¹ / ₁₆	28 ³ / ₄	23 ⁹ / ₁₆	16	16 ¹ / ₄	23 ⁵ / ₈	15	22 ¹ / ₂	15	22 ¹ / ₂	
Subbase for Coil Cabinets											
NAHH004SB	15 ¹¹ / ₁₆	20 ⁹ / ₁₆	14 ⁹ / ₁₆	16 ¹ / ₄	16 ¹ / ₄	14 ⁵ / ₈	15	13 ¹ / ₂	15	13 ¹ / ₂	
NAHH005SB	19 ⁵ / ₁₆	20 ⁹ / ₁₆	18 ³ / ₁₆	16 ¹ / ₄	16 ¹ / ₄	18 ¹ / ₄	15	17 ¹ / ₈	15	17 ¹ / ₈	
NAHH006SB	23	20 ⁹ / ₁₆	21 ¹³ / ₁₆	16 ¹ / ₄	16 ¹ / ₄	21 ¹ / ₈	15	19 ³ / ₄	15	19 ³ / ₄	
NAHH009SB	24 ³ / ₄	20 ⁹ / ₁₆	23 ⁹ / ₁₆	16 ¹ / ₁₆	16 ¹ / ₄	23 ⁵ / ₈	15	22 ¹ / ₂	15	22 ¹ / ₂	

* Outside Dimension
** Base Spacer Side To Side

3. Set the base over the opening in the floor, centering it over the opening. Fasten the base to the floor with screws or nails. See **Figure 38**, **Figure 39** and **Figure 40**.

5. Position furnace or coil cabinet and furnace on subbase so it aligns between the locating tabs.

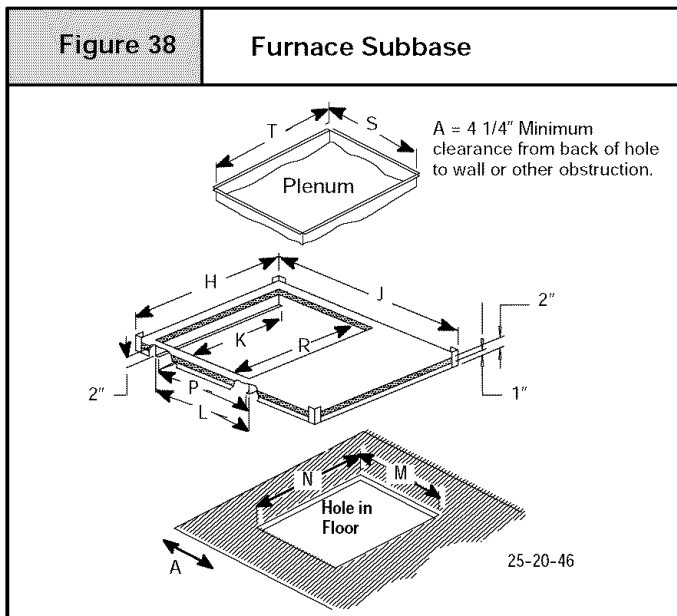

4. Drop the plenum through the opening in the base. The flange of the plenum should rest on top of the subbase.

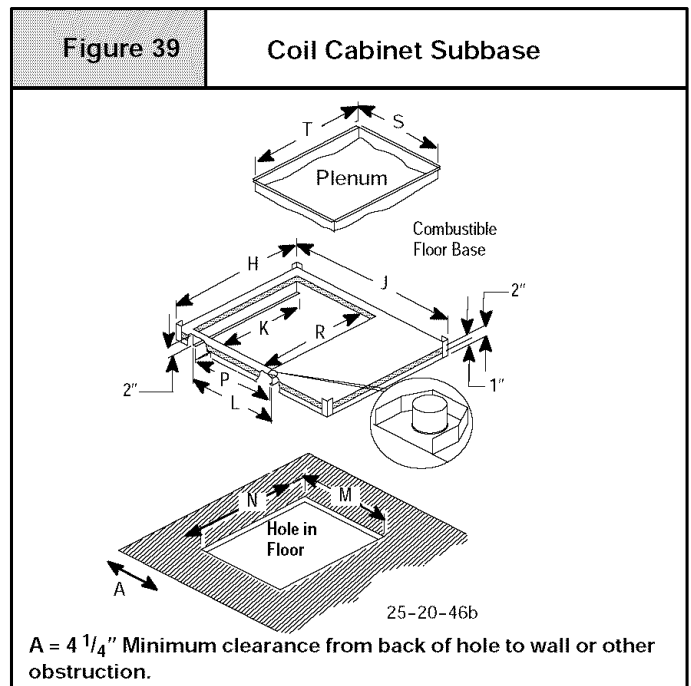

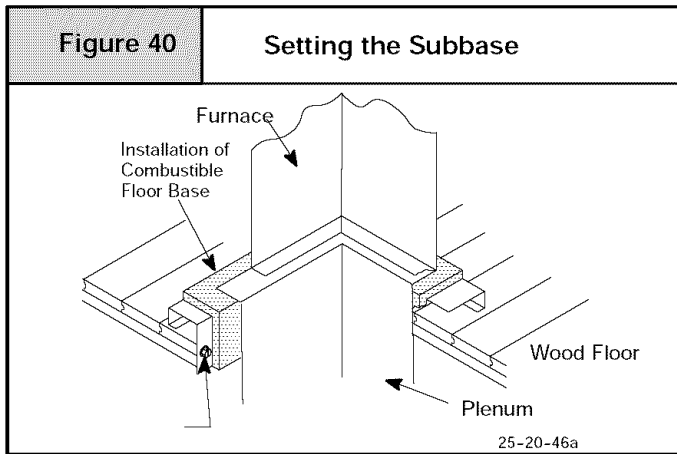

This subbase for combustible floors has been designed so that the height of the subbase raises the downflow coil off the floor to allow easy installation of the condensate drain. See Figure 41.

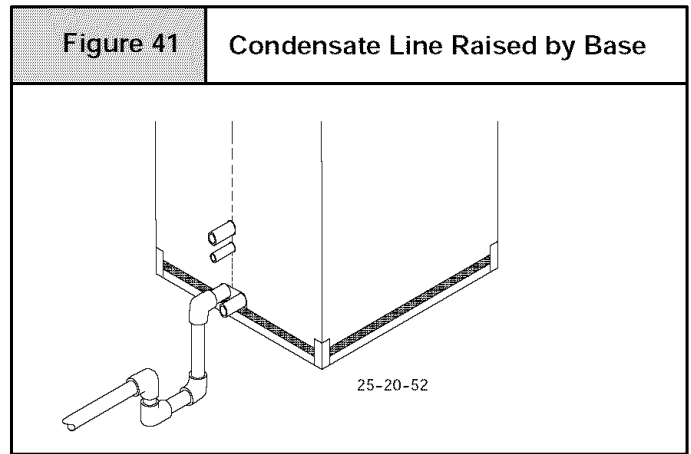

8. Checks and Adjustments

⚠ WARNING
FIRE OR EXPLOSION HAZARD.
 Failure to turn OFF gas at shut off before connecting manometer could result in death, personal injury and/or property damage.
 Turn OFF gas at shut off before connecting manometer.

Startup

NOTE: Refer to the start-up procedures in the "User's Information Manual" or to the "Operating Instructions Label" on the furnace.

⚠ WARNING
FIRE OR EXPLOSION HAZARD.
 Failure to correct hazard could result in death, personal injury, and/or property damage.
 If any sparks, odors or unusual noises occur, immediately shut OFF power to furnace. Check for wiring errors or obstruction to blower.

Gas Supply Pressure

Gas supply pressure should be within minimum and maximum values listed on rating plate. Pressures are usually set by gas suppliers.

Manifold Gas Pressure Adjustment

NOTE: Make adjustment to manifold pressure with burners operating.

1. Remove the burner compartment door.
2. With gas OFF, connect manometer to tapped opening on gas valve. Use manometer with a 0 to 15" water column range.

3. Turn gas ON and remove adjustment screw cover on gas valve. Turn counterclockwise to decrease pressure and clockwise to increase.
4. For altitudes up to 2000', set pressure to value shown in Table 6, $\pm 0.3"$ (8mm) water column. For altitudes of 2000' to 8000', see Section 5 for correct pressure setting.

Adjust Pilot Burner

The furnace has a pilot flame to light the main burner. The flame should surround $\frac{3}{8}"$ to $\frac{1}{2}"$ of the flame sensor. See Figure 42. To adjust, remove cap from pilot adjusting screw on gas valve. Turn screw counterclockwise to increase or clockwise to decrease flame as required. Replace adjusting screw cap.

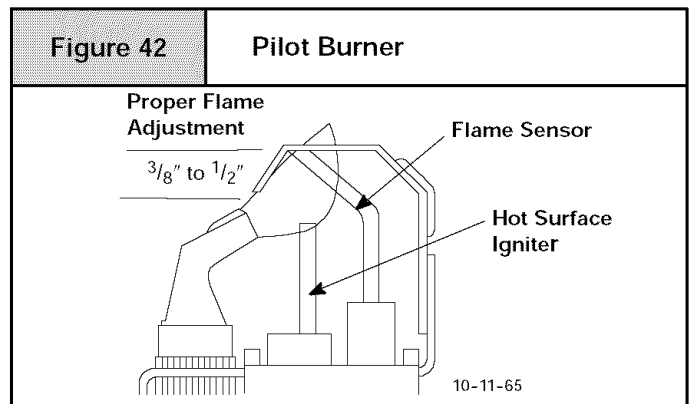

Main Burner Flame Check

Allow the furnace to run approximately 10 minutes then inspect the main burner and pilot flames. See Figure 43.

Check for the following (Figure 43):

- Stable and blue flames. Dust may cause orange tips or wisps of yellow, but flames **MUST NOT** have solid, yellow tips.
- Flames extending directly from burner into heat exchanger.
- Flames do **NOT** touch sides of heat exchanger.

If any problems with main burner flames are noted, it may be necessary to adjust gas pressures, or check for drafts.

Figure 43

Main Burner

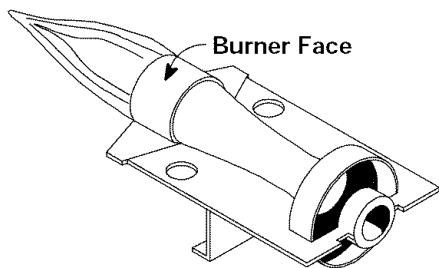

10-10-78

Temperature Rise Check

The blower speed **MUST** be set to give the correct air temperature rise through the furnace as marked on the rating plate for both high fire and low fire operation. Temperature rise is the difference between supply and return air temperatures.

To check temperature rise, use the following procedure:

1. Place thermometers in supply and return air registers as close to furnace as possible, avoiding direct radiant heat from heat exchangers.
2. Operate furnace on high fire for 10 minutes with all the registers and duct dampers open by using a jumper wire on R to W1 and W2 thermostat connections on the fan board.
Note: The fourth (4th) DIP switch should be in the on position. (See furnace wiring diagram)
3. Take readings and compare with range specified on rating plate.
4. If the temperature rise is not in the correct range, the blower speed must be changed. A higher blower speed will lower the temperature rise. A lower blower speed will increase the temperature rise.
5. Repeat steps 2 thru 4 with the furnace operating on low fire for 10 minutes by using a jumper wire on the R to W1 thermostat connections on the fan board.
6. Remove the jumper wire after the adjustments are complete. Return fourth (4th) to previous setting.

Changing Blower Speed (*9MPT Models)



WARNING

ELECTRICAL SHOCK HAZARD.

Failure to do so could result in death and/or personal injury.

Turn OFF power to furnace before changing speed taps.

NOTE: The speed taps that the manufacture sets from the factory for this product are based on a nominal 400 CFM per ton cooling and the basic mid range on the temperature rise for heating.

Since the manufacturer cannot establish the static pressure that will be applied to the unit, it is the responsibility of the installer dealer/contractor to select the proper speed taps for the application when the unit is installed.



CAUTION

REDUCED FURNACE LIFE HAZARD

Failure to properly set the air temperature rise may result in reduced furnace life.

Use **ONLY** the following blower motor speed taps for setting air temperature rise.

Blower Motor Speed Taps	Model Sizes	
	Heat High	Heat Low
Hi (BLK)	All	None
Med-Hi (O)	All	All
Med Lo (BL)	All except 100J	All
Lo (R)	None	050F12 and 125L20

If it is necessary to change speeds, refer to steps below.

1. Refer to *Furnace Wiring Diagram* for location of the heating and cooling speed taps located on the electronic fan control as well as location of unused blower motor speed leads. Use the chart (Table 9) to determine the blower motor speed settings.

Wire Color	Motor Speed
Black	High
Orange*	Med-High
Blue	Medium
Red	Low

* Med-High speed may not be provided on all models.

2. Change the heat or cool blower motor speed by removing the motor lead from the "Heat" or "Cool" terminal and replace it with the desired motor speed lead from the "Unused Motor Lead" location. Connect the wire previously removed from the "Heat" or "Cool" terminal to the vacated "Unused Motor Lead" terminal.
3. If the same speed must be used for both heating and cooling, remove the undesired motor speed lead from the "Heat" or "Cool" terminal and connect that lead to the open terminal at "Unused Motor Lead" location. Attach a jumper between the "Heat" and "Cool" terminals and the remaining motor speed lead.

Note: For motors with (4) speed leads, it will be necessary to tape off the terminal of the motor speed lead removed from the "Heat" or "Cool" terminal with electrical tape since an open terminal will not be available at the "Unused Motor Lead" location.

Continuous Fan Operation

A terminal is provided on the electronic fan control located in the circulating blower compartment for operation of the continuous fan option. This connection is intended for the low speed motor tap, and has a lower contact rating (8 amps) than the heat and cool taps. When the low speed blower lead is connected to this terminal, this will provide low speed blower operation whenever the other two speeds (Heat or Cool) are not energized.

Thoroughly check the system after modification to ensure the proper operation of the circulating air blower in all modes of operation.

Separate speed selections for Heat, Cool, and Continuous Fan

Connect low speed lead from circulating motor to the "Cont." terminal at the electronic fan control. The appropriate motor leads should already be connected to the "Heat" and "Cool" terminals.

Heating and Continuous Blower Speed the Same

If it is necessary to operate the heating speed and continuous blower speed using the same blower speed, connect a jumper between the "Heat" and "Cont." terminals on the electronic fan control.

Note: There should be only **ONE** motor lead going to the "Heat" and "Cont." terminals.

Changing Blower Speed (*9MPV Models)

⚠ WARNING

ELECTRICAL SHOCK HAZARD.

Failure to do so could result in personal injury and/or property damage.

Turn OFF power to furnace before changing speed taps.

NOTE: The blower speeds that the manufacturer sets from the factory for this product are based on a nominal 400 CFM per ton cooling and the mid range on the temperature rise for heating.

Since the manufacturer cannot establish the static pressure that will be applied to the unit, it is the responsibility of the installer dealer/contractor to select the proper speed taps for the application when the unit is installed.

If it is necessary to change speeds, refer to steps below.

1. The 115 VAC power supply to the furnace must be turned OFF before making adjustments to the motor.

NOTE: Allow at least 1 minute before restoring power to the furnace after making Blower Control changes.

2. The heating, cooling and continuous blower speeds can be adjusted by changing the switch settings that are located on the motor control (see **Figure 44**). Switches #1 and #2 adjust the continuous blower speeds. Switches #3, #4 and #5 adjust the heating speeds. Switches #6, #7 and #8 adjust the cooling speed. See the "*Technical Support Manual*" for the switch settings for the desired airflow rates for the installation.

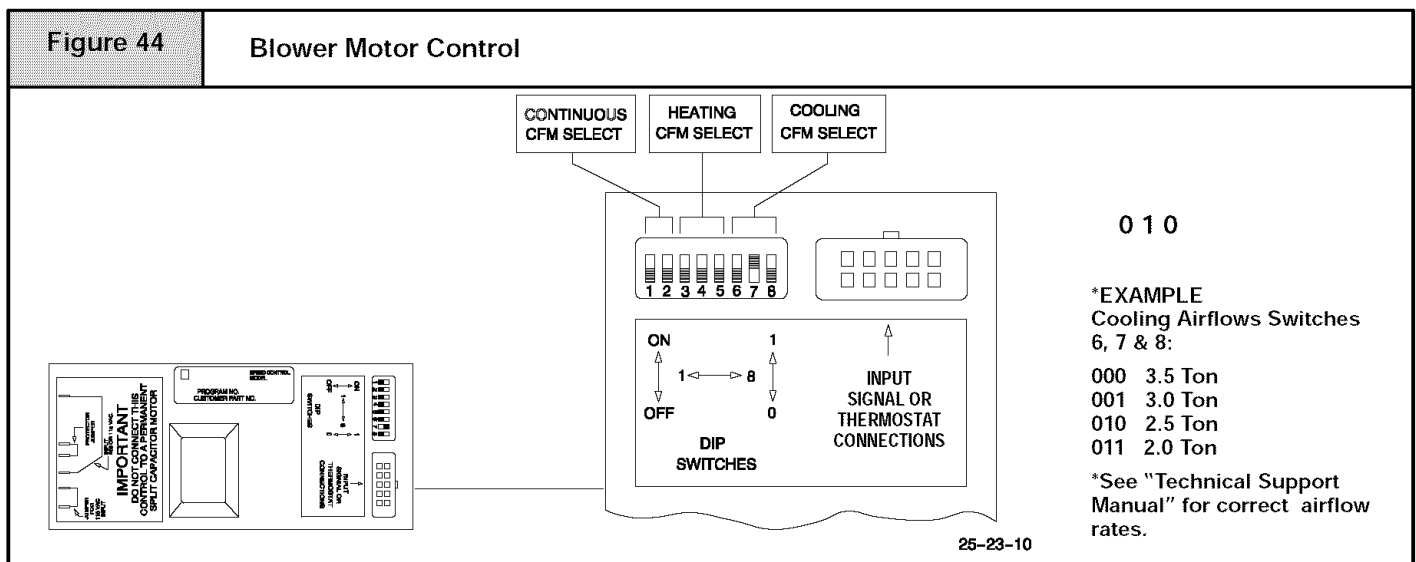

9. Furnace Maintenance

⚠ WARNING

FIRE, EXPLOSION, OR CARBON MONOXIDE HAZARDS

Failure to have the furnace inspected and maintained could result in fire, explosion, or carbon monoxide poisoning.

It is recommended that the furnace be inspected and serviced on an annual basis (before the heating season) by a qualified service technician.

⚠ WARNING

ELECTRICAL SHOCK, FIRE OR EXPLOSION HAZARD

Failure to follow safety warnings exactly could result in dangerous operation, serious injury, death or property damage.

Improper servicing could result in dangerous operation, serious injury, death or property damage.

- Before servicing, disconnect all electrical power to furnace.
- When servicing controls, label all wires prior to disconnecting. Reconnect wires correctly.
- Verify proper operation after servicing.

See "*User's Information Manual*" and the "*Service Manual*".

10. Sequence of Operation & Diagnostics

The following is the normal operating sequence for the 2-stage control system.

Cooling (Y) Request:

24 VAC signals applied to Y & G terminals of EFT (electronic fan timer) control.

- Cool motor speed energized after 5 second Cool Fan On Delay time.

Y & G signals removed from EFT.

- Cool motor speed de-energized after 90 second Cool Fan Off Delay time.

Cooling (Y) and dehumidification (Y2) requests:

- 24 VAC signals applied to Y, Y2 & G terminals of EFT (electronic fan timer) control.
- Same operation as the cooling (Y) request, except the cooling speed is reduced 20% to compensate for high humidity conditions during cooling operation. The cooling speed returns to the normal setting after the Y2 signal is removed.

Circulating Fan (G) Request:

24 VAC signals applied to G terminals of EFT control.

- Low motor speed energized without delay.

G signal removed from EFT.

- Low motor speed de-energized without delay.

NOTE1) Furnaces with DC blower motors run a low circulating fan speed in response to G request.

NOTE2) Furnaces with PSC blower motors de-energize the Low Heat fan speed during the heat exchanger warm-up period on a call for Heating that occurs during a G request.

NOTE3) Heating or Cooling requests received during a Fan request cause the fan speed to change to the appropriate heat or cool speed after the selected Fan On Delay time expires. The fan returns to circulating speed after the selected Fan Off Delay time expires following loss of the Heating or Cooling request.

Heating (W1) Request (single stage thermostat operation, 4th DIP switch must be in off position) (see furnace wiring diagram):

24 VAC signals applied to W1 terminal of EFT control.

- Inducer motor turns on at high speed.
- The high fire solenoid energizes.
- Following a 3 second prepurge delay, the pilot valve opens and the ignitor begins to warm up.
- After the pilot lights, the main burners energize and light (burners now at high fire rate).
- Timed from the opening of the main gas valve, the control will delay the selected Heat Fan On Delay time before switching the inducer to low speed, de-energizing the high fire solenoid and the fan switches to Low Heat speed.
- Timed from initial application of the Heating request, if the W1 request is still present after the selected Low Fire Delay time expires (12 minutes), the inducer switches to high speed, the high fire solenoid energizes and the fan switches to High Heat speed.

W1 signal removed from EFT.

- The gas valve de-energizes and the main burners go out.
- The inducer runs at its present speed for a 5 second postpurge period.
- The fan switches to (or stays at) Low Heat speed.
- Timed from the gas valve de-energizing, the Low Heat fan speed de-energizes after the selected Heat Fan Delay time expires.

NOTE4) If a new Heating request arrives while the control is waiting in the Heat Fan Off Delay time, the fan speed switches to High Heat until the Heat Fan Off Delay expires or the Heat Fan On Delay expires for the new Heating request.

Heating Request (two stage thermostat operation, 4th DIP switch must be in on position) (see furnace wiring diagram):

24 VAC signals applied to W1 terminal of EFT control.

- Same response as single stage thermostat operation described above except the control will not go to high fire, High Heat fan speed unless a W2 signal is applied.

24 VAC signals applied to W1 and W2 terminals of EFT control.

- Same light-off routine as described for the signal stage thermostat operation except that at the end of the selected Heat Fan On Delay, the inducer remains on high fire, the high fire solenoid remains energized and the High Heat fan speed energizes.

NOTE5) The EFT control responds without delay to the presence or loss of W2 (with W1 constant). W1 & W2 results in high inducer, high fire and High Heat fan speed. W1 only results in low inducer, low fire and Low Heat fan speed.

Heating Request with Gas Supply Line Shut Off:

24 VAC signals applied to W1 terminal of EFT control.

- Inducer motor turns on at high speed.
- The high fire solenoid energizes.
- Following a 3 second prepurge delay, the pilot valve opens and the ignitor begins to warm up.
- The ignitor glows red-hot for 30 seconds, then turns off.
- The igniter stays off for 25 seconds, then begins to warm-up again.
- The igniter glows red-hot for 30 seconds, then turns off.
- The pilot valve closes 3 seconds after the igniter de-energizes.
- The inducer de-energizes 5 seconds after the pilot valve closes.
- The SmartValve proceeds to soft lockout and flashes error code 6.
- The control exits soft lockout after 5 minutes and begins another ignition sequence.

Gas Valve Diagnostic Codes (See Figure 45)

OFF	= Control not powered
Heartbeat	= Normal Operation (Standby or call for heat)
1 Flash	= Not used
2 Flashes	= Low Pressure switch closed when should be open
3 Flashes	= Low Pressure switch circuit was still sensed as open 30 seconds after the inducer was energized. System is in 5 minute delay mode, with inducer off. After 5-minute delay, a new ignition sequence will be initiated. (Note: SV9541Q On/Off switch in off position during a call for heat will generate this diagnostic code)
4 Flashes	= Limit switch string open
5 Flashes	= Flame sensed out of sequence - Flame signal still present.
6 Flashes + 1 Note 1	= Soft Lockout -Maximum retry count exceeded (failed to light within 4 trials for ignition)
6 Flashes + 2 Notes 1,2	= Soft Lockout -Maximum recycle count exceeded - Last failure was Flame Sense Lost During Run, Cycling Pressure Switch or Blocked Condensate.
6 Flashes + 3 Notes 1,2	= Soft Lockout -Maximum recycle count exceeded - Last failure was Airflow Proving Circuit Opened During Run
6 Flashes + 4 Notes 1,2	= Soft Lockout -Maximum recycle count exceeded - Last failure was Limit Circuit Opened During Run
7 Flashes	= Soft Lockout Due to Limit Trips Taking Longer than 2 minutes to Reset; Auto Reset After 1 Hour if Call for Heat Still Present. Reset by Cycling Call for Heat at Any Time.
8 Flashes	= High Pressure Switch closed when should be open.
9 Flashes	= High Pressure Switch open when should be closed.

NOTE 1: The 6 + X designation indicates a combination of flash codes: 6 flashes shows the control is in soft lockout, followed by X flashes to indicate the reason the control went into soft lockout. When the 6+ X code is flashing, the SV9541 will attempt a new ignition sequence after a five minute delay period, if the call for heat is still present. Reset of the thermostat will initiate a new ignition sequence immediately.

NOTE 2: Any combination of 5 'abnormal' events during a single call for heat will result in soft lockout. An 'abnormal' event is a Flame Sense Failure During Run, Airflow Proving Circuit Open During Run, or Limit Circuit Open During Run. The flash code will indicate which was the last 'abnormal' event that put the system into the soft lockout state based on the table above.

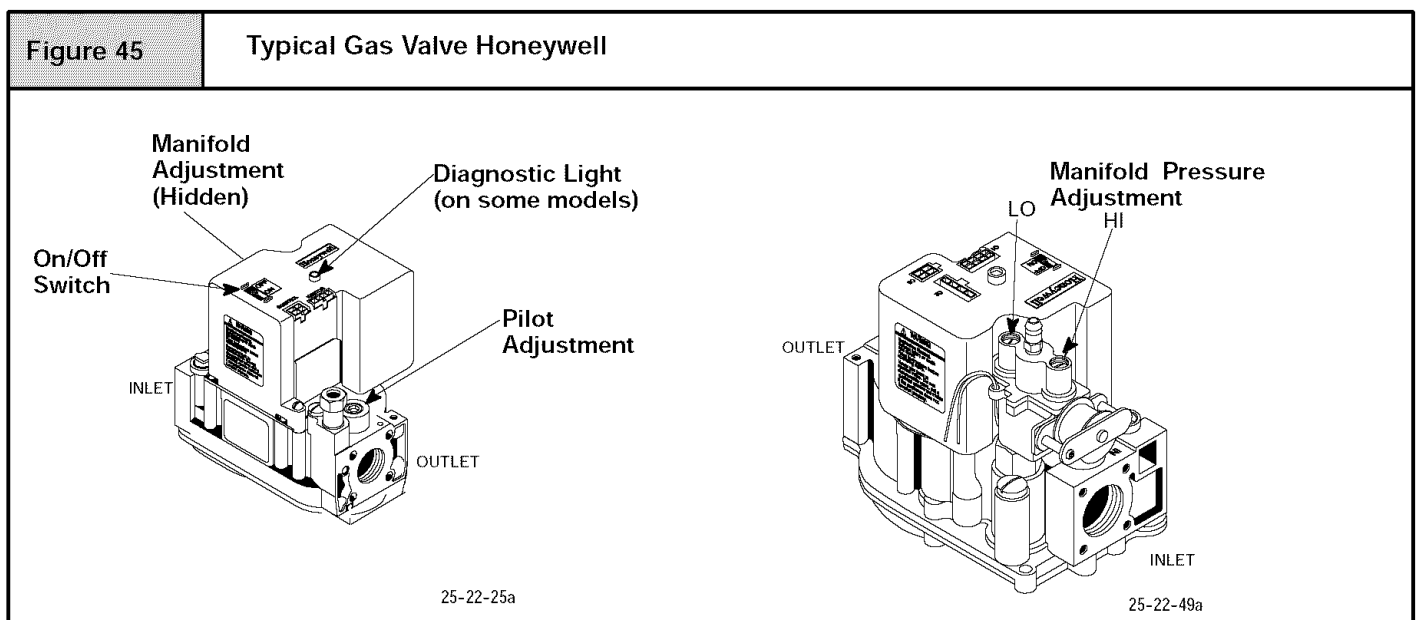

HONEYWELL SV9541Q "SMART VALVE" Sequence of Operation

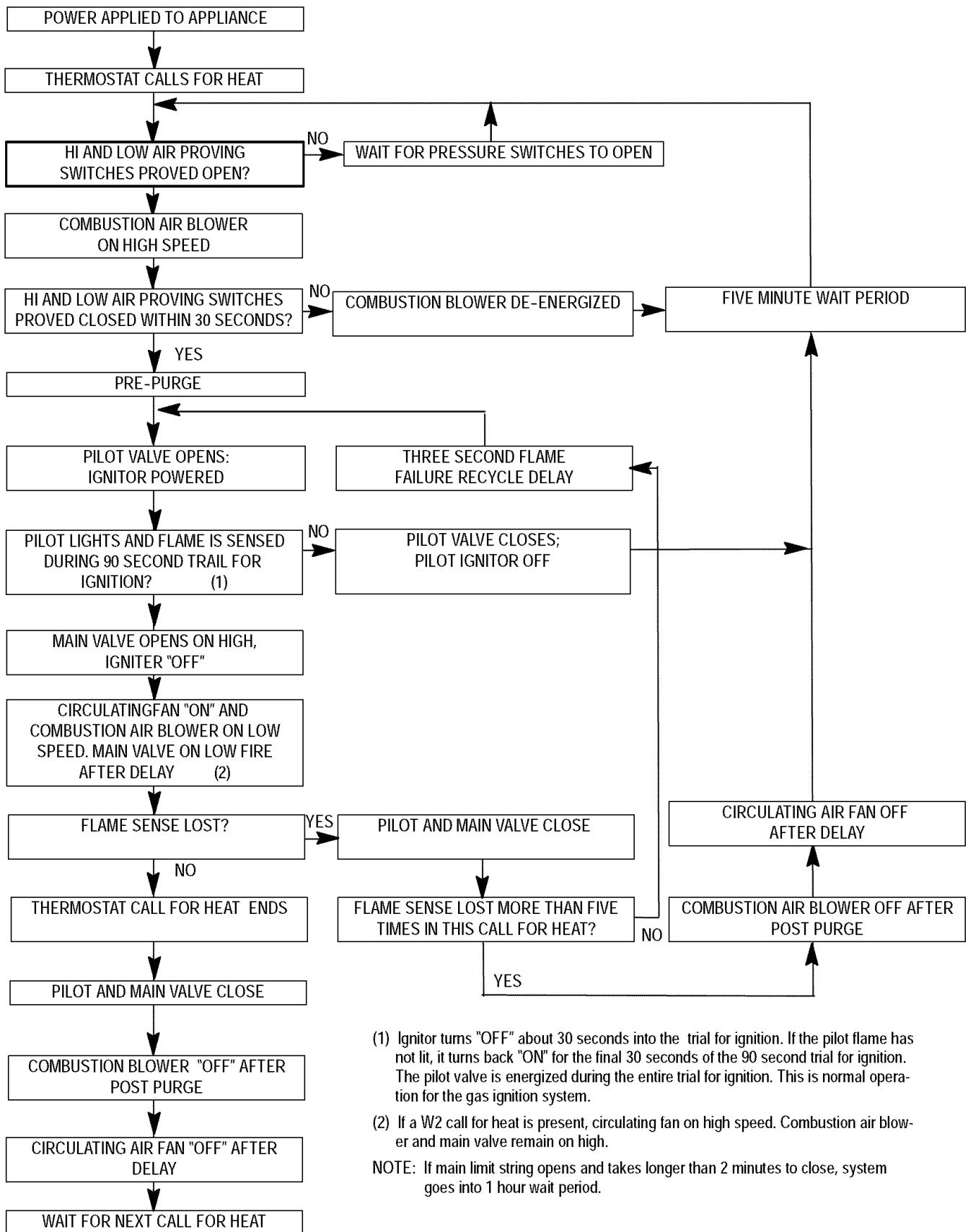

(1) Ignitor turns "OFF" about 30 seconds into the trial for ignition. If the pilot flame has not lit, it turns back "ON" for the final 30 seconds of the 90 second trial for ignition. The pilot valve is energized during the entire trial for ignition. This is normal operation for the gas ignition system.

(2) If a W2 call for heat is present, circulating fan on high speed. Combustion air blower and main valve remain on high.

NOTE: If main limit string opens and takes longer than 2 minutes to close, system goes into 1 hour wait period.

HONEYWELL SV9541Q "SMART VALVE" Trouble shooting

The 6 + X designation indicates a combination of flash codes: 6 flashes shows the control is in soft lockout, followed by X flashes to indicate the reason the control went into soft lockout. Last status code indicates repair to address first

LED STATUS	INDICATES	CHECK/REPAIR
Off	No power to system control.	Line voltage input at L1 and Neutral connectors on ST9162A Fan Timer. Low voltage (24V) power at 24 VAC and COM terminals on ST9162A System wiring harness is in good condition and securely connected.
Heartbeat Bright - Dim	Normal indication whenever the system is powered, unless some abnormal event has occurred.	Not Applicable - Normal Operation (stand by or call for heat)
2 Flashes	Low pressure switch closed when it should be open (i.e. when call for heat begins). (Combustion blower is not energized until pressure switches opens)	Pressure switch stuck closed (system will wait for pressure switch to open). Pressure switch miswired or jumpered.
3 Flashes	Low pressure switch, open when it should be closed (i.e. longer than 30 seconds after combustion blower/inducer is energized). System goes into 5-minute delay period, with combustion blower/inducer off. At end of the 5-minute delay, another cycle will begin.	Ignition system control switch must be in the ON position. Pressure switch operation, tubing, and wiring. Restrictions in furnace air intake or vent piping.
4 Flashes	Main Limit or Roll Out Switch is open. Combustion blower is energized, Circulating blower is energized heat speed.	Main limit switch. Manual reset burner rollout switch. Limit and rollout switch wiring is in good condition and securely connected.
5 Flashes	Flame signal sensed out of proper sequence. Combustion blower is energized, Circulating blower is energized heat speed after the "ON" delay.	Flame at pilot burner.
6 Flashes + 1 Flash	Soft Lockout. Failed to light pilot during 90 sec. trial for ignition Combustion air blower is de-energized, Circulating blower is de-energized after the "OFF" delay. After 5-minute delay time, control system will reset and initiate a new ignition sequence,	Gas supply off or pressure too low or high for appliance to operate. Damaged or broken HSI element Line voltage HOT lead wire not connected to L1 terminal on ST9162A. Furnace not properly earth grounded. Flame sense rod contaminated or in incorrect position. Pilot burner located in incorrect position. Pilot burner lead wires are in good condition and properly connected. Pressure switches operation, tubing, and wiring.
6 Flashes + 2 Flashes	Soft Lockout. Last failure was Flame Sense lost during run. Maximum recycle count exceeded Combustion air blower is de-energized, Circulating blower is de-energized after the "OFF" delay. After 5-minute delay time, control system will reset and initiate a new ignition sequence,	Gas supply off or pressure too low or high for appliance to operate. Line voltage HOT lead wire not connected to L1 terminal on ST9162A. Furnace not properly earth grounded. Flame sense rod contaminated or in incorrect position. Pilot burner located in incorrect position. Pilot burner lead wires are in good condition and properly connected. Cycling, pressure switch Condensate drain blocked Pressure switches operation, tubing, and wiring.

HONEYWELL SV9541Q "SMART VALVE" Trouble shooting continued

LED STATUS	INDICATES	CHECK/REPAIR
6 Flashes + 3 Flashes	<p>Soft Lockout.</p> <p>Last failure was pressure switch</p> <p>Maximum recycle count exceeded</p> <p>Combustion air blower is de-energized, Circulating blower is de-energized after the "OFF" delay.</p> <p>After 5-minute delay time, control system will reset and initiate a new ignition sequence,</p>	<p>Ignition system control switch must be in the ON position.</p> <p>Pressure switches operation, tubing, and wiring.</p> <p>Restrictions in furnace air intake or vent piping.</p> <p>High winds blowing against vent.</p>
6 Flashes + 4 Flashes	<p>Soft Lockout.</p> <p>Last failure was limit circuit opened during run.</p> <p>Combustion air blower is de-energized, Circulating blower is de-energized after the "OFF" delay.</p> <p>After 5-minute delay time, control system will reset and initiate a new ignition sequence,</p>	<p>Main limit switch.</p> <p>Limit and rollout switch wiring is in good condition and securely connected.</p> <p>Restriction in duct work.</p> <p>Dirty filter</p>
7 Flashes	<p>Soft Lockout.</p> <p>Blower failure (typical)</p> <p>Limit trip took longer than 2 minutes to reset.</p> <p>System will start a new ignition sequence after 1 hour, if call for heat still present.</p>	<p>Dead blower.</p> <p>Blocked duct work.</p>
8 Flashes	<p>High Pressure closed when should be open. (i.e., when call for heat begins).</p> <p>(Combustion blower is not energized until pressure switches open)</p>	<p>Pressure switches stuck closed (system will wait for pressure switch to open).</p> <p>Pressure switch miswired or jumpered.</p>
9 Flashes	<p>High Pressure open when should be closed. (i.e., longer than 30 seconds after combustion/inducer is energized).</p> <p>System goes into a 5 minute delay period with combustion blower/inducer "OFF". At end of the 5 minute delay another cycle begins.</p>	<p>Ignition system control switch must be in the "ON" position.</p> <p>Pressure switch operation, tubing and wiring.</p> <p>Restrictions in furnace air intake or vent piping.</p>

11. Concentric Vent Termination

Vent Termination Clearances

⚠ WARNING

CARBON MONOXIDE POISONING, FIRE AND EXPLOSION HAZARD.

Failure to properly vent this furnace could result in death, personal injury and/or property damage.

Inlet and outlet pipes may NOT be vented directly above each other (standard vent terminals).

1. Determine termination locations based on clearances specified in following steps and as shown in **Figure 7**, **Figure 46** through **Figure 51**.
2. The vent termination must be located at least 12" above ground or normally expected snow accumulation levels.
3. Do **NOT** terminate over public walkways. Avoid areas where condensate may cause problems such as above planters, patios, or adjacent to windows where steam may cause fogging.
4. The vent termination shall be located at least 4' horizontally from any electric meter, gas meter, gas regulator, and any relief equipment. These distances apply **ONLY** to U.S. installations.
5. The vent termination is to be located at least 3' above any forced air inlet located within 10' ; and at least 10' from a combustion air intake of another appliance, except another direct vent furnace intake.
6. In Canada, the *Canadian Fuel Gas Code* takes precedence over the preceding termination instructions.

Concentric Vent Termination - Kit # NAHA001CV & NAHA002CV

These kits are for vertical or horizontal termination of the combustion air inlet and the exhaust vent pipes on Category IV gas-fired condensing furnaces. The NAHA001CV kit can be used for 3" diameter pipe systems. The NAHA002CV kit can be used for 2" diameter pipe system. Refer to **Table 10** for the correct pipe size for the furnace. Both the combustion air inlet and the exhaust vent pipes must attach to the termination kit. The termination kit must terminate outside the structure and must be installed per the instructions outlined below for vertical or horizontal termination. Vertical termination is preferred. Field supplied pipe and fittings are required to complete the installation.

Vertical & Horizontal Termination

1. Determine the pipe diameters required for the installation from **Table 10** and **Figure 48**.
2. Determine the best location for the termination kit. See **Figure 47** for vertical termination or **Figure 46** and **Figure 51** for horizontal termination. Roof termination is preferred since it is less susceptible to damage, has reduced intake contaminants and less visible vent vapor. For side wall termination, consideration should be given to: 1) possible damage from the vapors to plants/shrubs, other equipment and building materials, 2) possible damage to the terminal from foreign objects, 3) wind effects that may cause recirculation of flue products, debris or light snow and 4) visible vent vapor.

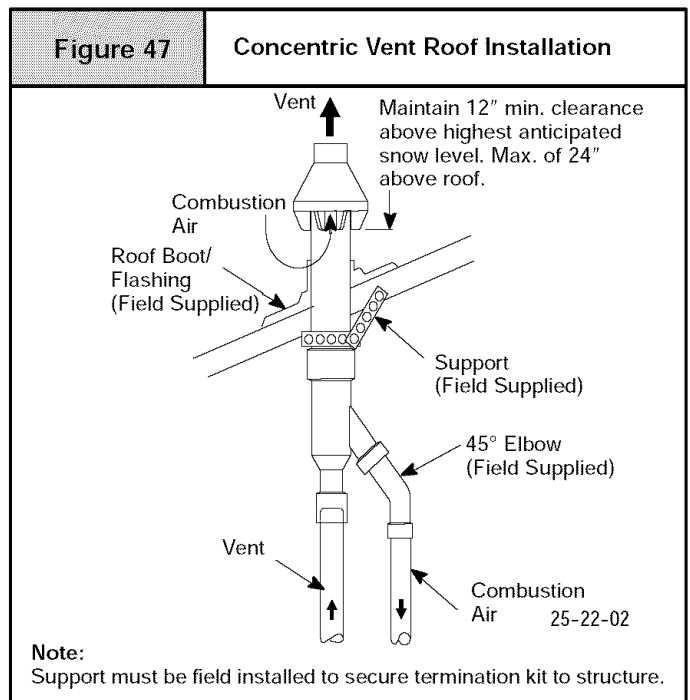
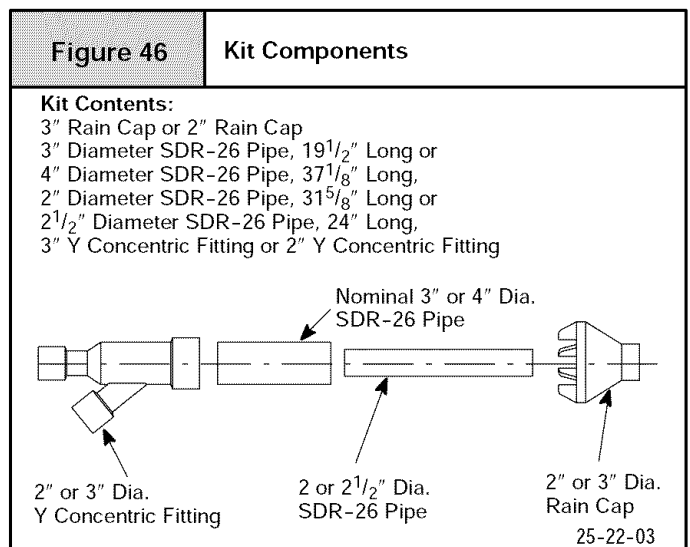

3. Cut one 5" diameter hole through the structure for the NAHA001CV Kit or one 4" diameter hole for the NAHA002CV Kit .
4. Dimension D may be lengthened to 60" max. or shortened by cutting the pipes to 12" min. Dimension A will change according to D dimension. (See **Figure 48**)

Figure 48

Concentric Vent Dimensional Drawing

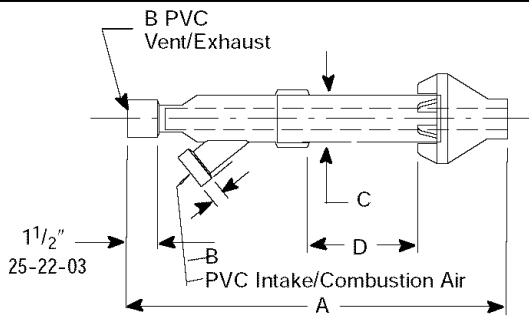

Model	A*	B	C	D**
NAHA001CV	33 ³ / ₈	2	3 ¹ / ₂	16 ¹ / ₈
NAHA002CV	38 ¹ / ₈	3	4 ¹ / ₂	21 ¹ / ₈

* = Dimension will change accordingly as dimension D is lengthened or shortened.
 ** = Dimension D may be lengthened to 60" may also be shortened by cutting the pipes provided in the kit to 12" minimum

Table 10

**Concentric Termination Kit
 NAHA001CV & NAHA002VC Venting
 Table Dual Piping ONLY**

50,000 & 75,000 Btuh Furnace

NAHA002CV - 35' & (4) 90° elbows with 2" PVC pipe

100,000 & 125,000 Btuh Furnace

NAHA001CV - 35' & (4) 90° elbows with 3" PVC pipe

1. Do not include the field supplied 45° elbow in the total elbow count.
2. If more than four elbows are required, reduce the length of both the inlet and the exhaust pipes five feet for each additional elbow used.
3. Elbows are DWV long radius type for 2" and 3" vents.

If more than four elbows are required, reduce the length of both the inlet and exhaust pipes 5' for each additional elbow used.

*Feet of pipe is whichever pipe run is the longest, either inlet or outlet side.

If assembly needs to be extended to meet height or side wall thickness requirement, the two pipes supplied in the kit may be replaced by using the same diameter solid, single (no coupling connections) field supplied SDR-26 PVC (ASTM D2241) pipes. Do not extend dimension D more than 60". (See Figure 48)

Do not use field supplied couplings to extend the pipes. Airflow restriction will occur and the furnace pressure switch may cause intermittent operation.

5. Partially assemble the concentric vent termination kit. Clean and cement the parts using the procedures for Joining Pipe and Fittings section of the manual. A) Cement the Y Concentric fitting to the 4" diameter kit pipe. (See Figure 49) B) Cement the 3" rain cap to the 2¹/₂" diameter kit part. (See Figure 49) NOTE: A field supplied stainless steel screw may be used to secure the rain cap to the pipe instead of cementing when field disassembly is desired for cleaning (See Figure 49)

Figure 49

Rain Cap to Vent Pipe Assembly

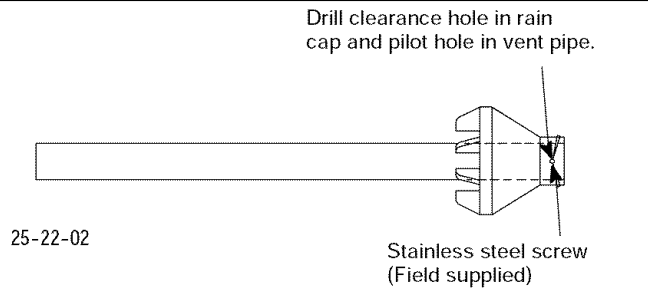

⚠ WARNING

CARBON MONOXIDE POISONING HAZARD.
 Failure to follow this warning could result in death, personal injury and/or property damage.
 When using the alternate screw assembly method, drill a clearance hole in the rain cap and a pilot hole in the vent pipe for the screw size being used. Failure to drill adequate holes may cause cracking of the PVC components, allowing flue gases to be recirculated.

⚠ WARNING

CARBON MONOXIDE POISONING HAZARD.
 Failure to follow this warning could result in death, personal injury and/or property damage.
 Do not operate the furnace with the rain cap removed as recirculation of the flue gases may occur. Water may also collect inside the larger combustion air pipe and flow to the burner enclosure.

6. Install the Y concentric fitting and the pipe assembly through the structure's hole. For vertical termination, install the parts through the field supplied roof boot/flashing. NOTE: Do not allow insulation or other materials to accumulate inside the pipe assembly when installing through the structure's hole.
7. Secure the assembly to the structure as shown in Figure 47 or Figure 51 using field supplied metal strapping or equivalent material.
 NOTE: Ensure the termination height is above the roof surface or anticipated snow level as shown in Figure 47 for vertical termination. Ensure the termination location clearance dimensions are as shown in Figure 50 and Figure 51 for horizontal termination.

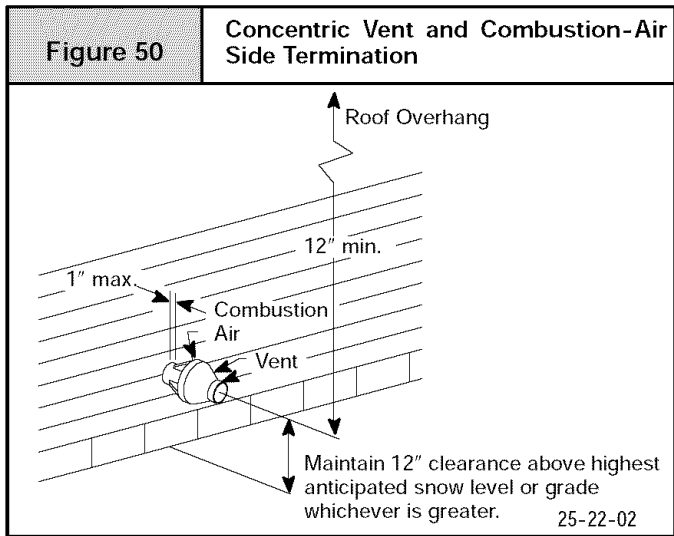

8. Install the rain cap and the small diameter pipe assembly in the Y concentric fitting and the large pipe assembly. Ensure that the small diameter pipe is bottomed out and securely cemented in the Y concentric fitting.
9. Cement the furnace combustion air and vent pipes to the concentric vent termination assembly. See **Figure 47** or **Figure 51** for proper pipe attachment.
10. Operate the furnace through one heat cycle to ensure combustion air and vent pipes are properly connected to the concentric termination connections.

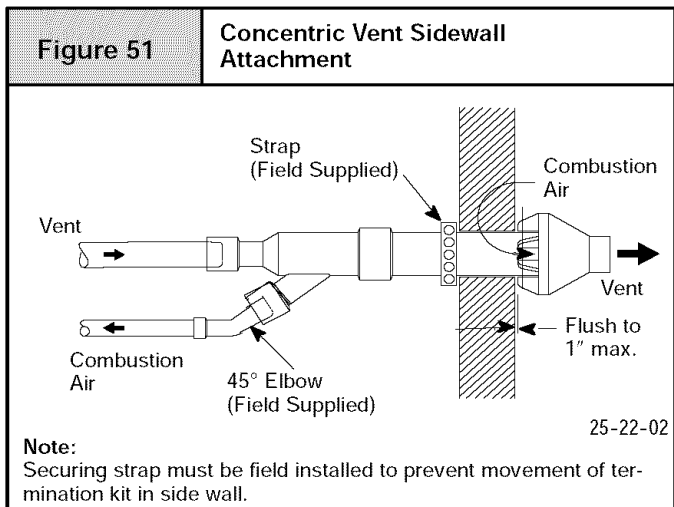

Technical Support Manual

Four Position Furnace

Models

Dual Certified

*9MPT050F12B1
*9MPT075F14B1
*9MPT100J16B1
*9MPT125L20B1

*9MPV050F12B1
*9MPV075F12B1
*9MPV100J16B1
*9MPV125L20B1

* Denotes Brand

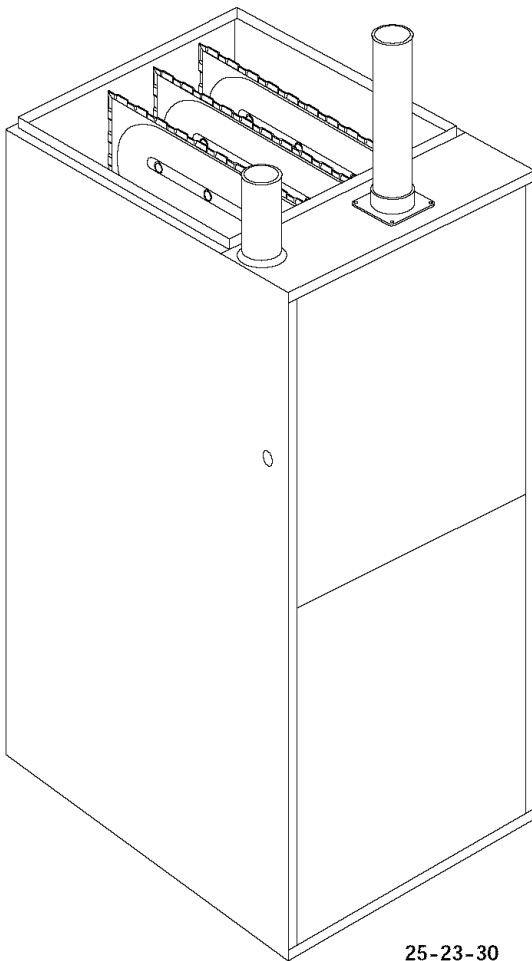

25-23-30



International Comfort Products, LLC
Lewisburg, TN 37091
Fast Parts Division
866-380-3278

Save This Manual For Future Reference

TECHNICAL SUPPORT

Specifications								
	*9MPT050F12B		*9MPT075F14B		*9MPT100J16B		*9MPT125L20B	
General	Nat	L.P.	Nat	L.P.	Nat	L.P.	Nat	L.P.
Gas Type								
Transformer Size (VA)	40							
T'stat Heat Anticipator	.10							
Input (Btuh) Std/Alt. Hi Fire	50,000		75,000		100,000		125,000	
Lo Fire	35,000		53,000		70,000		87,500	
Output (Btuh) Std/Alt. Hi Fire	46,000		67,500		92,000		115,000	
Lo Fire	32,200		48,800		64,400		80,500	
Temp. Rise (°F) Hi Fire	35-65		40-70		40-70		40-70	
Lo Fire	25-55		30-60		30-60		30-60	
Electrical (Volts/Hz/FLA)	115/60/9.8		115/60/9.0		115/60/9.0		115/60/11.2	
Gas & Ignition								
Gas Type	Nat.	L.P.	Nat.	L.P.	Nat.	L.P.	Nat.	L.P.
Std. Main Orifices (No/Size)	2/42	2/54	3/42	3/54	4/42	4/54	5/42	5/54
Gas Valve (Honeywell)	SV 9541	SV 9541	SV 9541	SV 9541	SV 9541	SV 9541	SV 9541	SV 9541
Regulation Type	SNAP	SNAP	SNAP	SNAP	SNAP	SNAP	SNAP	SNAP
Manifold Press. Hi Fire (" WC)	3.5	10.0	3.5	10.0	3.5	10.0	3.5	10.0
Lo Fire (" WC)	1.7	4.9	1.7	4.9	1.7	4.9	1.7	4.9
Pilot Orifice Size	.018	.011	.018	.011	.018	.011	.018	.011
Ignition Type/Series	HSP	HSP	HSP	HSP	HSP	HSP	HSP	HSP
Combustion								
Flue Outlet Size (Inches)	2		2		3		3	
Std. Outlet Temp (° F)	<140		<140		<140		<140	
@ Blower / @ Transition Box (Hi Fire)								
Std. Pressures (" of WC)								
5' No Elbows	-1.80 / -2.60		-1.80 / -2.60		-1.80 / -2.60		-1.80 / -2.60	
40' +5-90° DWV Elbows	-1.30 / -2.30		-1.30 / -2.30		-1.70 / -2.50		-1.70 / -2.50	
@ Blower / @ Transition Box (Lo Fire)								
Std. Pressures (" of WC)								
5' No Elbows	-1.20 / -1.90		-1.20 / -1.90		-1.20 / -1.90		-1.30 / -2.30	
40' +5-90° DWV Elbows	-1.00 / -1.80		-1.00 / -1.80		-1.00 / -1.80		-1.20 / -2.20	
Fan Controls								
Fan Control (Type)	HW ST9162A							
Fan Control On	30/60							
(Timed-secs) Off	60,100,140,180							
Limits & Controls								
Rollout Switch (°F)	300		300		300		300	
Limit Control Setting (°F)	260		210		240		180	
Std. Pressure Sw. (Part No)	1013515		1013515		1013515		1013166	
Blower Switch Pressure (Close)	0.95		0.95		0.95		1.30	
Blower Switch Pressure (Open)	0.80		0.80		0.80		1.10	
Transition Switch Pressure (Close)	1.70		1.70		1.70		1.80	
Transition Switch Pressure (Open)	1.50		1.50		1.50		1.60	
High Altitude Pressure Sw. (Part No)	1013165		1013165		1013165		1013157	
Blower Switch Pressure (Close)	0.70		0.70		0.70		0.85	
Blower Switch Pressure (Open)	0.55		0.55		0.55		0.70	
Transition Switch Pressure (Close)	1.40		1.40		1.40		1.70	
Transition Switch Pressure (Open)	1.20		1.20		1.20		1.50	
Blower Data								
Type & Size	11-8		11-10		11-10		11-10	
Motor Amps/Rpm	10/1050		10/1050		10/1050		13/900	
Motor Type/H.p.	PSC/1/2		PSC/1/2		PSC/1/2		PSC ³ / ₄	
Cap. Mfd/Volts	10/370		10/370		10/370		40/370	
Filter Type & Size (Permanent - supplied)	16x25x1		16x25x1		16x25x1		16x25x1 (2)	
Cool Cap. (Tons) @ .5" W.C. L, ML, MHi & Hi	1 1/2, 2, 2 1/2, 3		1 1/2, 2, 2 1/2, 3.5		2 1/2, 3, 3 1/2, 4		3 1/2, 4, 4 1/2, 5	
Gas Conversion Kits All Models								
Nat to LP	NAHF002LP *1011789							
LP to Nat	NAHF002NG *1011787							
*Order from Service Parts								

CIRCULATION AIR BLOWER DATA

For 050 Models 3 Ton Units

External Static Pressure Inches of W.C.	Speed Tap	Low	Med L	Med H	Hi
	0.1	826	1083	1301	1408
	0.2	804	1050	1242	1347
	0.3	770	1028	1195	1295
	0.4	735	985	1153	1237
	0.5	698	952	1093	1183
	0.6	657	909	1040	1118
	0.7	---	863	935	1053
	0.8	----	812	865	976
	0.9	---	---	802	887
	1.0	---	---	720	787

For 075 Models 3.5 Ton Units

External Static Pressure Inches of W.C.	Speed Tap	Low	Med L	Med H	Hi
	0.1	695	1025	1455	1724
	0.2	674	1001	1410	1662
	0.3	653	951	1366	1601
	0.4	631	921	1309	1530
	0.5	609	891	1252	1460
	0.6	569	845	1187	1380
	0.7	529	799	1122	1300
	0.8	490	730	1030	1190
	0.9	---	680	950	1080
	1.0	---	---	831	969

For 100 Models 4 Ton Units

External Static Pressure Inches of W.C.	Speed Tap	Low	Med L	Med H	Hi
	0.1	823	1109	1527	1850
	0.2	795	1087	1482	1791
	0.3	747	1056	1426	1720
	0.4	677	1016	1382	1648
	0.5	617	970	1317	1575
	0.6	544	854	1245	1485
	0.7	---	763	1154	1401
	0.8	---	652	1043	1284
	0.9	---	---	905	1161
	1.0	---	---	737	1028

For 125 Models 5 Ton Units

External Static Pressure Inches of W.C.	Speed Tap	Low	Med L	Med H	Hi
	0.1	1720	1910	2127	2315
	0.2	1686	1881	2087	2268
	0.3	1644	1833	2024	2201
	0.4	1600	1777	1961	2131
	0.5	1533	1720	1891	2029
	0.6	1494	1647	1804	1948
	0.7	1413	1571	1708	1820
	0.8	1306	1470	1604	1730
	0.9	----	1349	1484	1614
	1.0	----	----	1328	1430

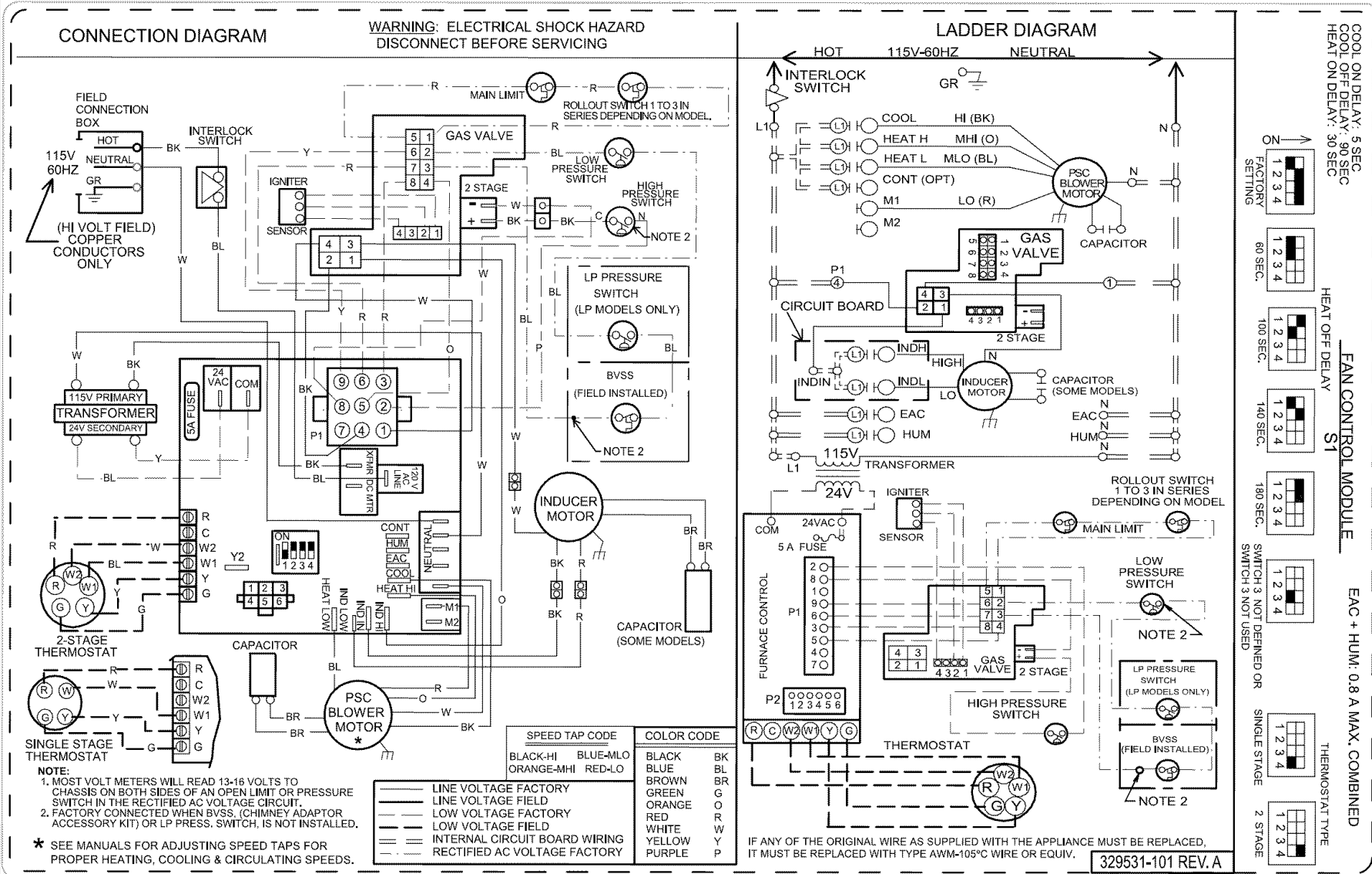

FAN CONTROL MODULE S1

EAC + HUM: 0.8 A MAX. COMBINED

THERMOSTAT TYPE

COOL ON DELAY: 5 SEC	HEAT OFF DELAY: 100 SEC.	FAN CONTROL MODULE S1	THERMOSTAT TYPE
COOL OFF DELAY: 90 SEC	HEAT ON DELAY: 30 SEC	ON	1 2 3 4
		FACTORY SETTING	1 2 3 4
		60 SEC.	1 2 3 4
		100 SEC.	1 2 3 4
		140 SEC.	1 2 3 4
		180 SEC.	1 2 3 4
		SWITCH 3 NOT DEFINED OR SWITCH 3 NOT USED	1 2 3 4
		SINGLE STAGE	1 2 3 4
		2 STAGE	1 2 3 4

25-23-95c

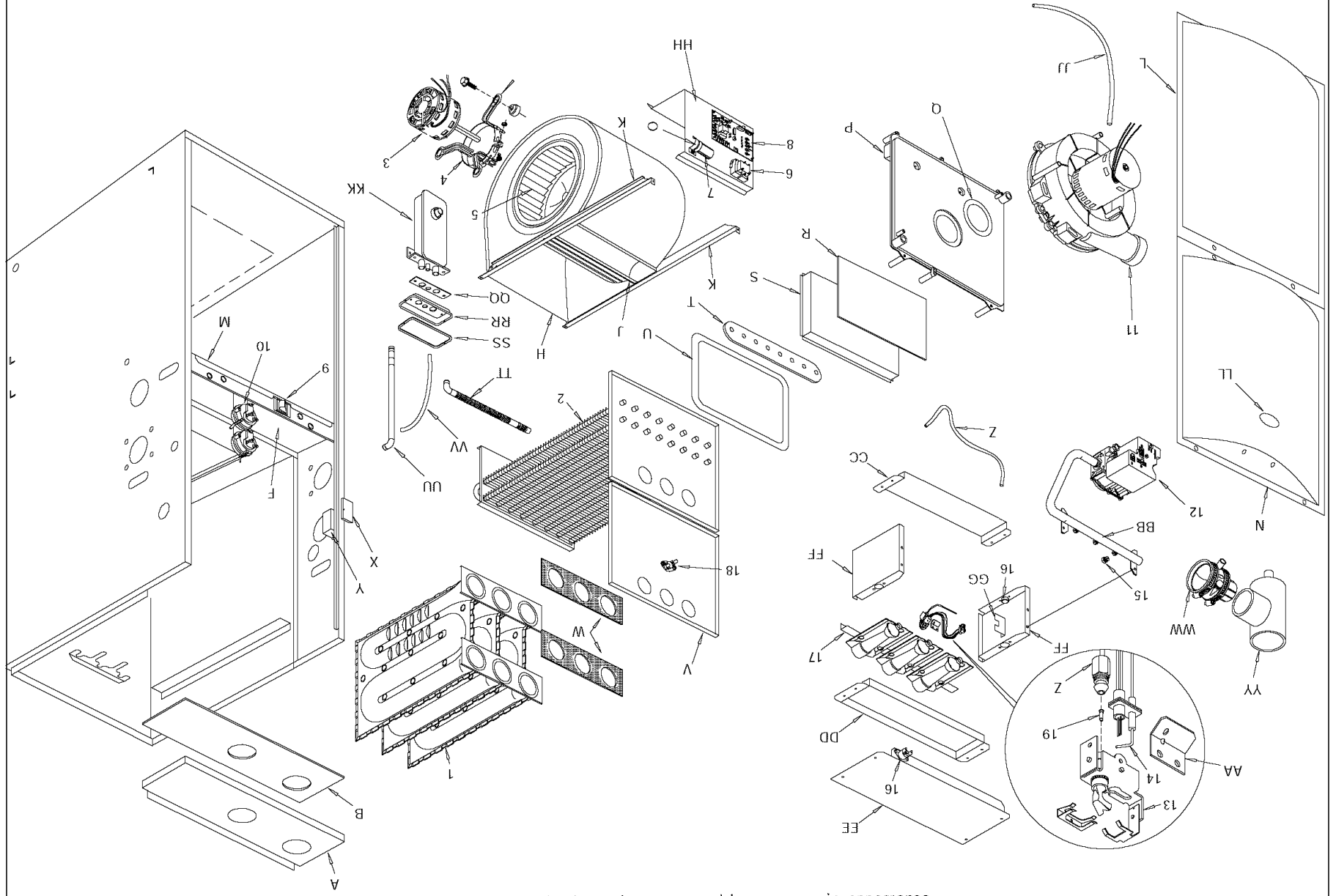

Representative drawing only, some models may vary in appearance.

25-23-95

Replacement Parts - *9MPT

Models - *9MPT050F12B1, *9MPT075F14B1, *9MPT100J16B1 & *9MPT125L20B1 (Natural Gas)

Replacement part supplied will be current active part. For parts not listed, consult place of purchase.

Key No.	Description Functional	Part Number	*9MPT			
			050 F12	075 F14	100 J16	125 L20
1	Heat Exchanger, Primary	1012850	1	-	-	-
		1012854	-	1	-	-
		1012858	-	-	1	-
		1012862	-	-	-	1
2	Heat Exchanger, Secondary	1013762	1	-	-	-
		1013763	-	1	-	-
		1013765	-	-	1	-
		1013767	-	-	-	1
3	Motor, Blower 1/115 1/2 CCW 1/115 3/4 CCW	1172488	1	1	1	-
		1172489	-	-	-	1
4	Mount, Motor kit*	1014824	1	-	-	-
		1014823	-	1	1	1
5	Wheel, Blower	1013011	1	-	-	-
		1011420	-	1	1	1
6	Transformer	1012722	1	1	1	1
7	Capacitor, 10Mfd., 370V 40Mfd., 370V	1171929	1	1	1	-
		1171982	-	-	-	1
8	Control, Fan Timer	1014459	1	1	1	1
9	Switch, Interlock	1171981	1	1	1	1
10	Switch, Pressure	1013166	-	-	-	1
		1013515	1	1	1	-
11	Blower, Exhaust	1014339	1	1	1	-
		1014340	-	-	-	1
12	Valve, Gas HSP Nat. 2 Stage	1013351	1	1	1	1
13	Burner, Pilot HSP	1008731	1	1	1	1
14	Igniter/Sensor HSP	1009524	1	1	1	1
15	Orifice, Burner #42 Nat.	1011351	2	3	4	5
16	Switch, Limit (Rollout)	1013102	2	2	2	2
17	Burner Assembly	1008723	1	-	-	-
		1008724	-	1	-	-
		1008725	-	--	1	-
		1008726	-	--	-	1
18	Switch, Limit (Main)	1320366	1	-	-	-
		34335002	-	-	1	-
		1008445	-	-	-	1
		34335001	-	1	-	-
19	Orifice, Pilot .018	503211	1	1	1	1
20	Filter, HH 16X25X1/2"	1010365	1	1	2	2

*See Table below for bellyband location on motor

Bellyband Location on Motor	
Model *9MPT	A(in.)
050F12B1	2.09"
075F14B1	1.81"
100J16B1	1.81"
125L20B1	1.65"

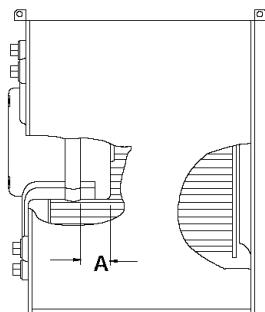

Key No.	Description Non-Functional	Part Number	*9MPT			
			050 F12	075 F14	100 J16	125 L20
A	Panel, Top	1012866	1	1	-	-
		1012867	-	-	1	-
		1012868	-	-	-	1
B	Gasket, Top Panel	1012603	1	1	-	-
		1012604	-	-	1	-
		1012605	-	-	-	1
F	Partition, Blower	1172008	1	-	-	-
		1172005	-	1	-	-
		1172006	-	-	1	-
		1172007	-	-	-	1
H	Housing, Blower	1012972	1	-	-	-
		1012888	-	1	1	1
J	Panel, Blower Cutoff	721020013	1	-	-	-
		721020008	-	1	1	1
K	Hanger, Blower	1012328	2	2	2	2
L	Door, Blower (Comfortmaker only) (Comfortmaker only) (Comfortmaker only) (Heil only) (Heil only) (Heil only) (Tempstar only) (Tempstar only) (Tempstar only)	1014203	1	1	-	-
		1014206	-	-	1	-
		1014209	-	-	-	1
		1014204	1	1	-	-
		1014207	-	-	1	-
		1014210	-	-	-	1
		1014205	1	1	-	-
1014207	-	-	1	-		
1014211	-	-	-	1		
M	Bracket Asy., Door Filler	1013680	1	1	-	-
		1013681	-	-	1	-
		1014494	-	-	-	1
N	Door, Front (Comfortmaker only) (Comfortmaker only) (Comfortmaker only) (Heil only) (Heil only) (Heil only) (Tempstar only) (Tempstar only) (Tempstar only)	1014194	1	1	-	-
		1014197	-	-	1	-
		1014200	-	-	-	1
		1014195	1	1	-	-
		1014198	-	-	1	-
		1014201	-	-	-	1
		1014196	1	1	-	-
1014199	-	-	1	-		
1014202	-	-	-	1		
O	Clamp, Capacitor	1170643	1	1	1	-
		1014315	-	-	-	1
P	Transition Assembly	1012281	1	1	-	-
		1012282	-	-	1	-
		1012283	-	-	-	1
Q	Gasket, Blower	1014425	1	1	1	1
R	Board, Insulating	1012418	1	1	-	-
		1012419	-	-	1	-
		1012420	-	-	-	1
S	Box, Collector	1012244	1	1	-	-
		1012245	-	-	1	-
		1012246	-	-	-	1
T	Gasket, Transition	1013263	1	-	-	-
		1013080	-	1	-	-
		1013083	-	-	1	-
		1013084	-	-	-	1
U	Gasket, Collector Box	1012594	1	1	-	-
		1012595	-	-	1	-
		1012596	-	-	-	1
V	Partition, Front Heat Exchanger	1012650	1	-	-	-
		1012648	-	1	-	-
		1012651	-	-	1	-
		1012653	-	-	-	1

Replacement Parts - *9MPT

Models - *9MPT050F12B1, *9MPT075F14B1, *9MPT100J16B1 & *9MPT125L20B1 (Natural Gas)

Replacement part supplied will be current active part. For parts not listed, consult place of purchase.

Key No.	Description Functional	Part Number	*9MPT			
			050 F12	075 F14	100 J16	125 L20
W	Gasket, Attachment Plate	1012542	2	-	-	-
		1012543	-	2	-	-
		1012544	-	-	2	-
		1012545	-	-	-	2
X	Cover, Junction Box	1012350	1	1	1	1
Y	Box, Junction	1012349	1	1	1	1
Z	Tube, Pilot	1012832	1	-	1	-
		1013189	-	1	-	-
		1013077	-	-	-	1
AA	Bracket, Pilot	1010901	1	1	1	1
BB	Manifold	1012970	1	-	-	-
		1012971	-	1	-	-
		1012278	-	-	1	-
		1012279	-	-	-	1
CC	Bottom, Burner Box	1012334	1	1	-	-
		1012335	-	-	1	-
		1012336	-	-	-	1
DD	Baffle, Burner Box	1012338	1	1	-	-
		1012339	-	-	1	-
		1012340	-	-	-	1
EE	Top, Burner Box	1013702	1	1	-	-
		1013703	-	-	1	-
		1013704	-	-	-	1
FF	Bracket, Manifold Support	1012377	2	2	2	2
GG	Bracket, Burner Box Side	1012532	2	2	2	2
HH	Bracket, Control Mounting	1013677	1	1	1	1
JJ	Tube, Sensor	1009238	1	1	1	1
KK	Trap, Drain Assembly	1171917	1	1	1	1
LL	Sightglass (Tempstar only)	1013235	1	1	1	1
		1013236	1	1	1	1
MM	Wrapper, Filter Rack	741010039	1	1	2	2
NN	Front, Filter Rack	741020001	1	1	2	2
OO	Cover, Filter	2791043	1	1	2	2
PP	Clip, Filter	1008482	3	3	3	3
QQ	Gasket, Trap	1013701	1	1	1	1
RR	Bracket, Trap	1171986	1	1	1	1
SS	Bracket, Trap Bracket	1171987	1	1	1	1
TT	Tube, Drain Coll. Box ⁵ / ₈ " ID	1171988	1	1	1	1
UU	Tube, Drain Tee ¹ / ₂ " ID	1171989	1	1	1	1
VV	Tube, Relief	1009238	1	1	1	1
WW	Drain Vent	1014003	1	1	1	1
YY	Tee, Drain	1171915	1	1	1	1
)	PART NOT ILLUSTRATED					
)	Door Screws	1014488	4	4	4	4
)	Door Screw Grommets	1171990	4	4	4	4
)	Coupling, Air Intake	1002284	1	1	1	1
)	Gasket, Air Intake	1012583	1	1	1	1
)	Clamp, Hose ⁵ / ₈ "	1012975	4	4	4	4
)	Clamp, Hose ³ / ₄ "	1012976	2	2	2	2
)	Coupling, Discharge	1002522	2	2	2	2
)	Clamp Hose	1013830	4	4	4	4
)	Grommet, Vent	1012697	1	1	1	1
)	Bushing, Strain Relief	1945287	1	1	1	1
)	Grommet, Vinyl (Gas Inlet)	1009535	1	1	1	1
)	Harness, Wire	1013689	1	1	-	-
)		1013690	-	-	1	1

Key No.	Description Functional	Part Number	*9MPT			
			050 F12	075 F14	100 J16	125 L20
)	Trap, Drain Tee	1171916	1	1	1	1
)	Tube, Drain ¹ / ₂ " ID Drain	1171991	1	1	1	1
)	Tube, ¹ / ₂ " Elbow	1171992	2	2	2	2
)	Coupling, ¹ / ₂ " Barbed	1171993	1	1	1	1
)	Tubing, ⁵ / ₈ " ID Drain	1171994	1	1	1	1
)	Connector, ³ / ₄ " X ¹ / ₂ "	1171995	1	1	1	1
)	Elbow, ¹ / ₂ " CPVC street	1171996	1	1	1	1
)	Grommet, Casing	1170977	1	1	1	1
)	Tube, Relief Ext.	1009238	1	1	1	1
)	Connector, Relief Tube	1171998	1	1	1	1
)	Plate, Cover	1171999	1	1	1	1
)	Gasket, Cover Plate	1172000	1	1	1	1
)	Cap, Drain Tee	1172001	1	1	1	1
)	Clamp, Tee Cap	1172002	1	1	1	1
)	Manual, Users	44102201004	1	1	1	1
)	Manual, Installation	44001202005	1	1	1	1
Gas Conversion Kits - All models						
Nat to LP		*1011789				
LP to Nat		*1011787				
* Must be ordered from Service Parts						

TECHNICAL SUPPORT

Specifications									
	*9MPV050F12B		*9MPV075F12B		*9MPV100J20B		*9MPV125L20B		
General	Nat	L.P.	Nat	L.P.	Nat	L.P.	Nat	L.P.	
Gas Type									
Transformer Size (VA)	40								
T'stat Heat Anticipator	.10								
Input (Btuh) Std/Alt. Hi Fire	50,000		75,000		100,000		125,000		
Lo Fire	35,000		52,500		70,000		87,500		
Output (Btuh) Std/Alt. Hi Fire	46,000		70,500		92,000		115,000		
Lo Fire	32,200		48,800		64,400		80,500		
Temp. Rise (°F) Hi Fire	35-65		40-70		40-70		40-70		
Lo Fire	35-65		40-70		40-70		40-70		
Electrical (Volts/Hz/FLA)	115/60/9.8		115/60/8.9		115/60/9.0		115/60/11.2		
Gas & Ignition									
Gas Type	Nat.	L.P.	Nat.	L.P.	Nat.	L.P.	Nat.	L.P.	
Std. Main Orifices (No/Size)	2/42	2/54	3/42	3/54	4/42	4/54	5/42	5/54	
Gas Valve Honeywell	SV 9541	SV 9541	SV 9541	SV 9541	SV 9541	SV 9541	SV 9541	SV 9541	
Regulation Type	SNAP	SNAP	SNAP	SNAP	SNAP	SNAP	SNAP	SNAP	
Manifold Press. Hi Fire (" WC)	3.5	10.0	3.5	10.0	3.5	10.0	3.5	10.0	
Lo Fire (" WC)	1.7	4.9	1.7	4.9	1.7	4.9	1.7	4.9	
Pilot Orifice Size	.018	.011	.018	.011	.018	.011	.018	.011	
Ignition Type/Series	HW HSP								
Combustion									
Flue Outlet Size (Inches)	2		2		3		3		
Std. Outlet Temp (° F)	<140		<140		<140		<140		
Comb. Blower (MFD/Volts)	4/370		4/370		4/370		4/370		
@ Blower / @ Transition Box (Hi Fire)									
Std. Pressures (" of WC)									
5' No Elbows	-1.80 / -2.60		-1.80 / -2.60		-1.80 / -2.60		-1.80 / -2.60		
40' +5-90° DWV Elbows	-1.30 / -2.30		-1.30 / -2.30		-1.70 / -2.50		-1.70 / -2.50		
@ Blower / @ Transition Box (Lo Fire)									
Std. Pressures (" of WC)									
5' No Elbows	-1.20 / -1.90		-1.20 / -1.90		-1.20 / -1.90		-1.30 / -2.30		
40' +5-90° DWV Elbows	-1.00 / -1.80		-1.00 / -1.80		-1.00 / -1.80		-1.20 / -2.20		
Limits & Controls									
Rollout Switch (° F)	300		300		300		300		
Limit Control Setting (° F)	260		210		240		190		
Fan Control (Type)	HW ST9162A								
Fan Control On	30/60								
(Timed-secs) Off	60,100,140,180								
Std. Pressure Sw. (Part No)	1013515		1013515		1013515		1013166		
(Hi Fire)Blwer Switch Press (Close)	0.95		0.95		0.95		1.30		
Blower Switch Pressure (Open)	0.80		0.80		0.80		1.10		
(Lo Fire)Trans Switch Press (Close)	1.70		1.70		1.70		1.80		
Transition Switch Pressure (Open)	1.50		1.50		1.50		1.60		
High Altitude Pressure Sw. (Part No)	1013165		1013165		1013165		1013157		
(Hi Fire)Blwer Switch Press (Close)	0.70		0.70		0.70		0.85		
Blower Switch Pressure (Open)	0.55		0.55		0.55		0.70		
(Lo Fire)Trans Switch Press (Close)	1.40		1.40		1.40		1.70		
Transition Switch Pressure (Open)	1.20		1.20		1.20		1.50		
Blower Data									
Type & Size	11-8		11-10		11-10		11-10		
Motor Amps/Rpm	9.8/1050		8.9/1080		11.2/1150		11.2/1150		
Motor Type/H.p.	DC/1/2		DC/1		DC/1		DC/1		
Filter Type & Size (Permanent - supplied)	16x25x1		16x25x1		16x25x1		16x25x1 (2)		
Min. Cool Cap. (Tons)	1.5		1.5		2		2		
Max. Cool Cap. (Tons)	3		3		5		5		
Gas Conversion Kits All Models									
Nat to LP	*1011789								
LP to Nat	*1011787								
*Order from Service Parts									

Circulation Air Blower Data - *9MPV

Heating, Cooling & Continuous Airflow Settings

Continuous Blower (CFM) @ 0.10" Static

Switch Settings		Furnace Model			
#1	#2	50K	75K	100K	125K
0*	0*	540	540	700	703
0	1	660	660	860	821
1	0	780	780	1020	1000
1	1	900	900	1180	1160

*Factory Setting

Hi Heat Air Temperature Adjustment (° F)**

Switch Settings			Furnace Model			
#3	#4	#5	50K	75K	100K	125K
0**	0**	0**	0	0	0	0
0	0	1	3	2	3	2
0	1	0	6	4	5	6
0	1	1	14	6	9	11
1	0	0	17	11	13	13
1	0	1	-8	-4	-4	-5
1	1	0	-13	-4	-7	-5
1	1	1	-17	-4	-9	-5

*Factory setting

**Approximate air temperature change from factory setting @ 0.20" static on high heat).

Lo Heat Air Temperature Adjustment (° F)**

Switch Settings			Furnace Model			
#3	#4	#5	50K	75K	100K	125K
0**	0**	0**	0	0	0	0
0	0	1	1	1	1	6
0	1	0	4	2	2	8
0	1	1	7	3	5	12
1	0	0	11	6	8	16
1	0	1	-7	-4	-5	-1
1	1	0	-11	-6	-9	-4
1	1	1	-15	-9	-11	-7

*Factory setting

**Approximate air temperature change from factory setting @ 0.20" static on high heat).

Cooling (CFM) @ 0.50" Static

Switch Settings			Furnace Model			
#6	#7	#8	50K	75K	100K	125K
0*	0*	0*	1170	1395	2095	2059
0	0	1	1098	1197	1875	1859
0	1	0	991	1096	1642	1700
0	1	1	894	1000	1489	1621
1	0	0	807	907	1255	1410
1	0	1	697	799	1013	1191
1	1	0	621	650	830	986
1	1	1	556	543	750	800

*Factory setting

Blower Motor Settings

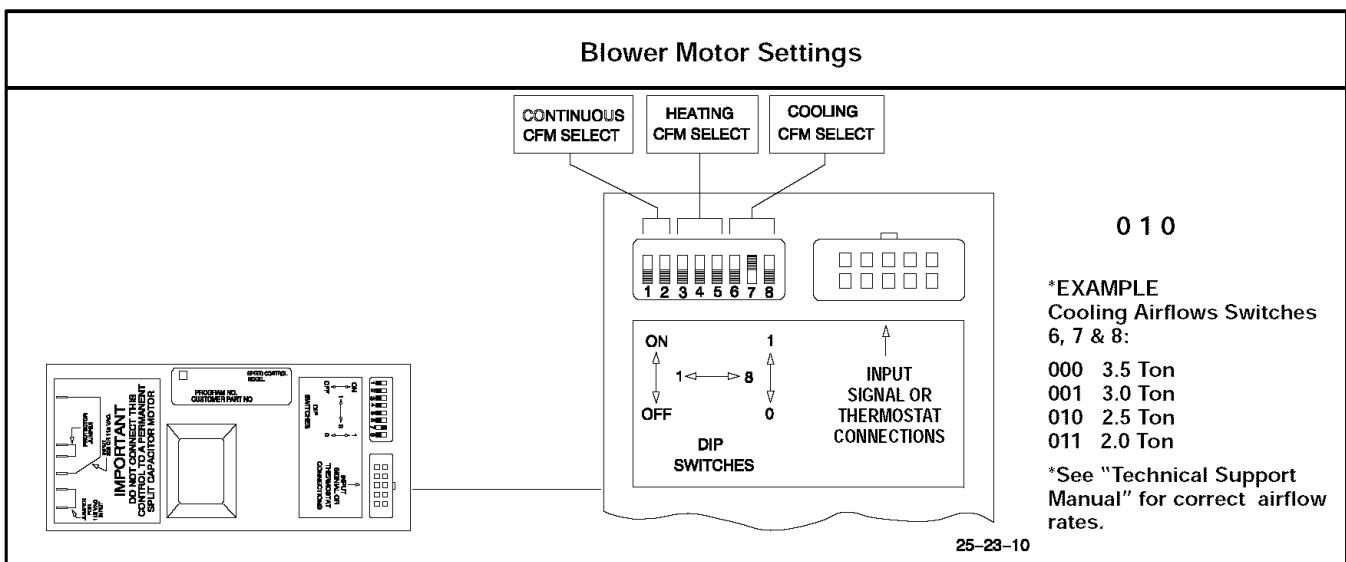

Circulation Air Blower Data - *9MPV

Heating, Cooling & Continuous Airflow Settings

Figure 1

***9MPV050 COOLING**
(CFM VS. EXTERNAL STATIC PRESSURE)

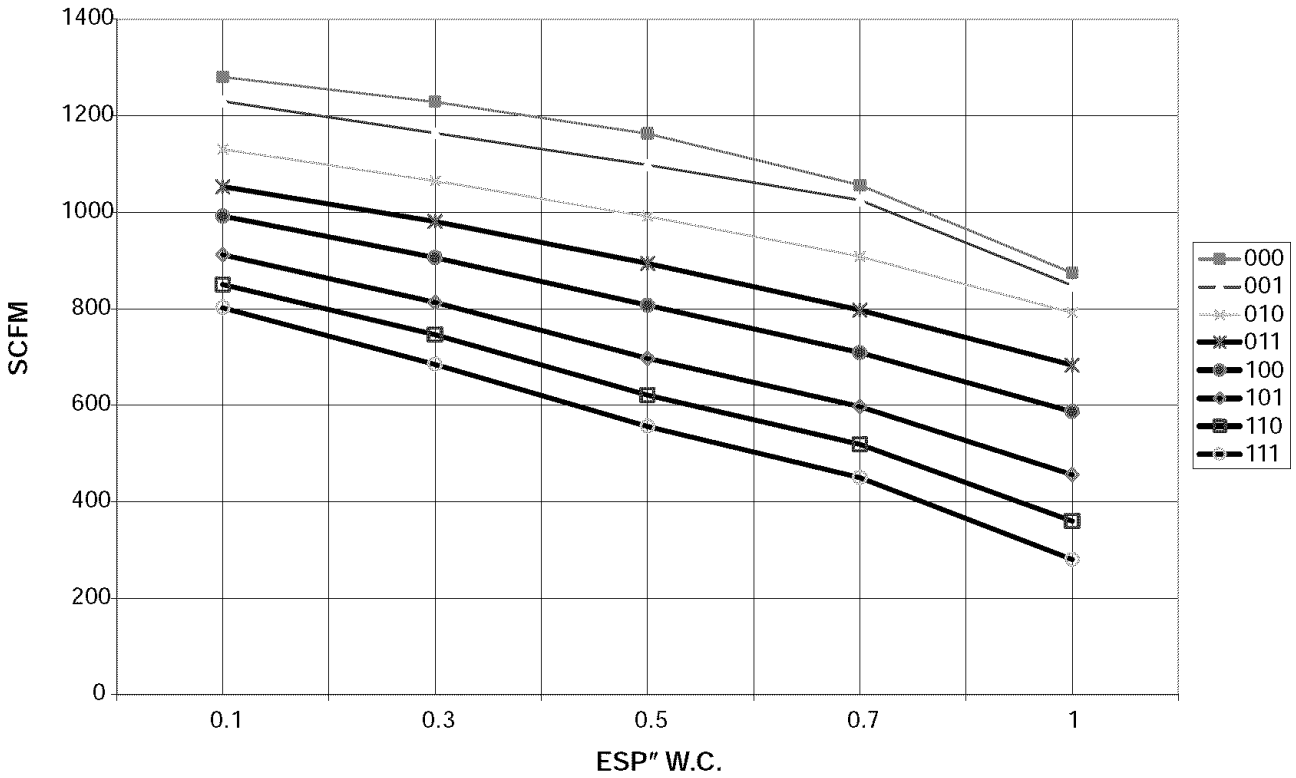
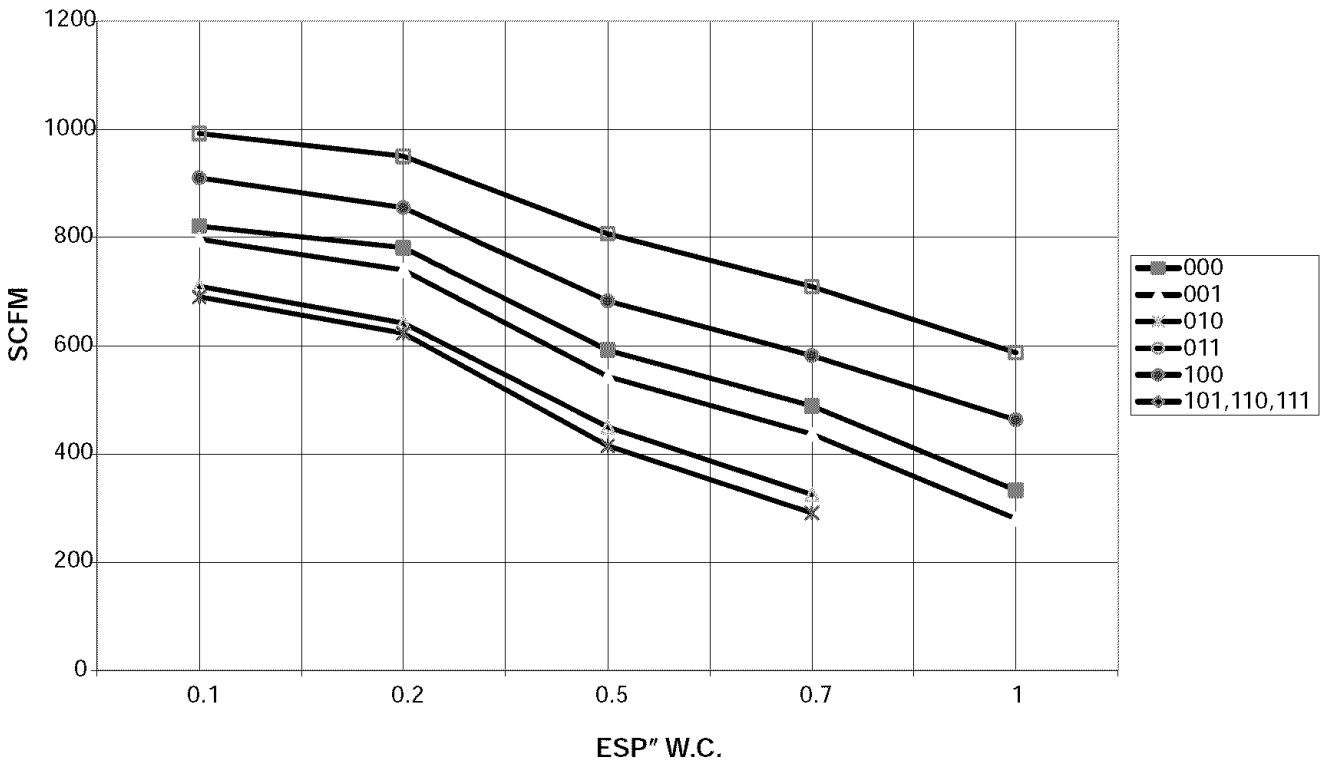

Figure 2

***9MPV050 Hi HEAT**
(CFM VS. EXTERNAL STATIC PRESSURE)



Circulation Air Blower Data - *9MPV

Heating, Cooling & Continuous Airflow Settings

Figure 3

***9MPV050 Lo HEAT**
(CFM VS. EXTERNAL STATIC PRESSURE)

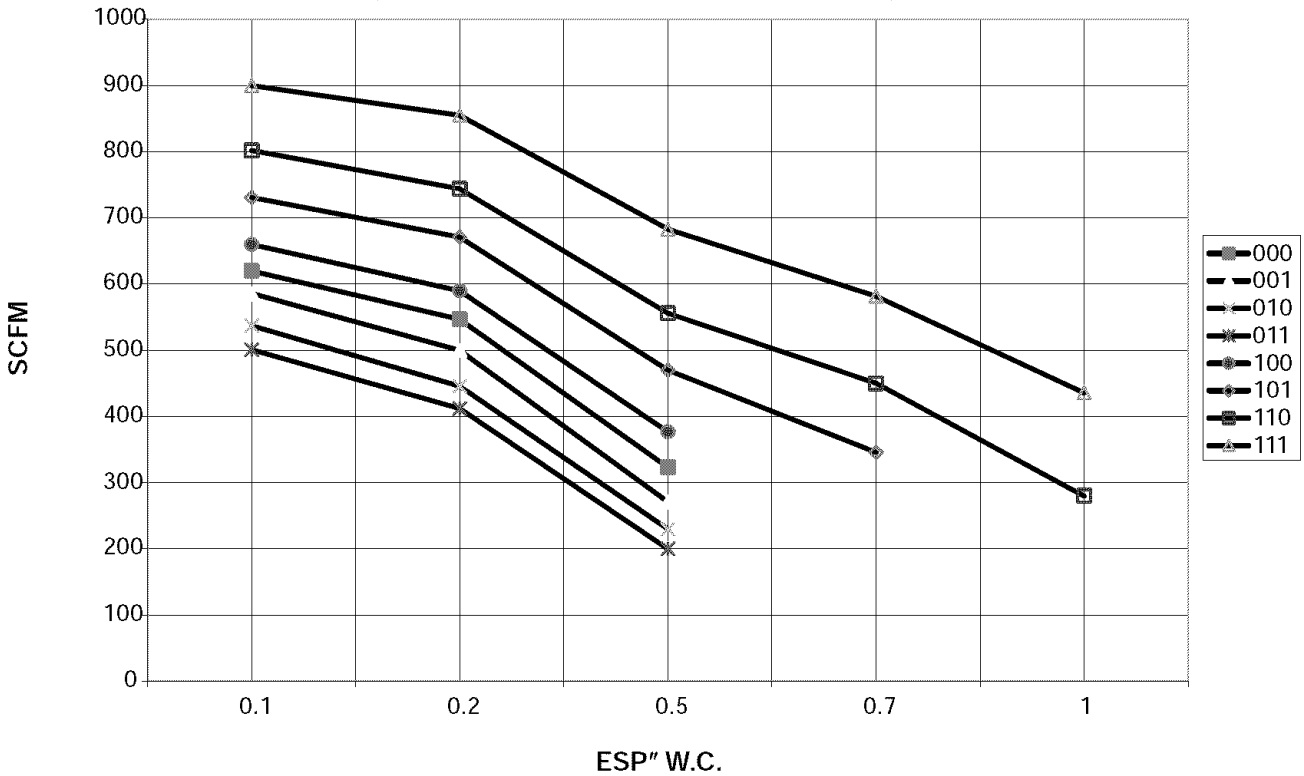
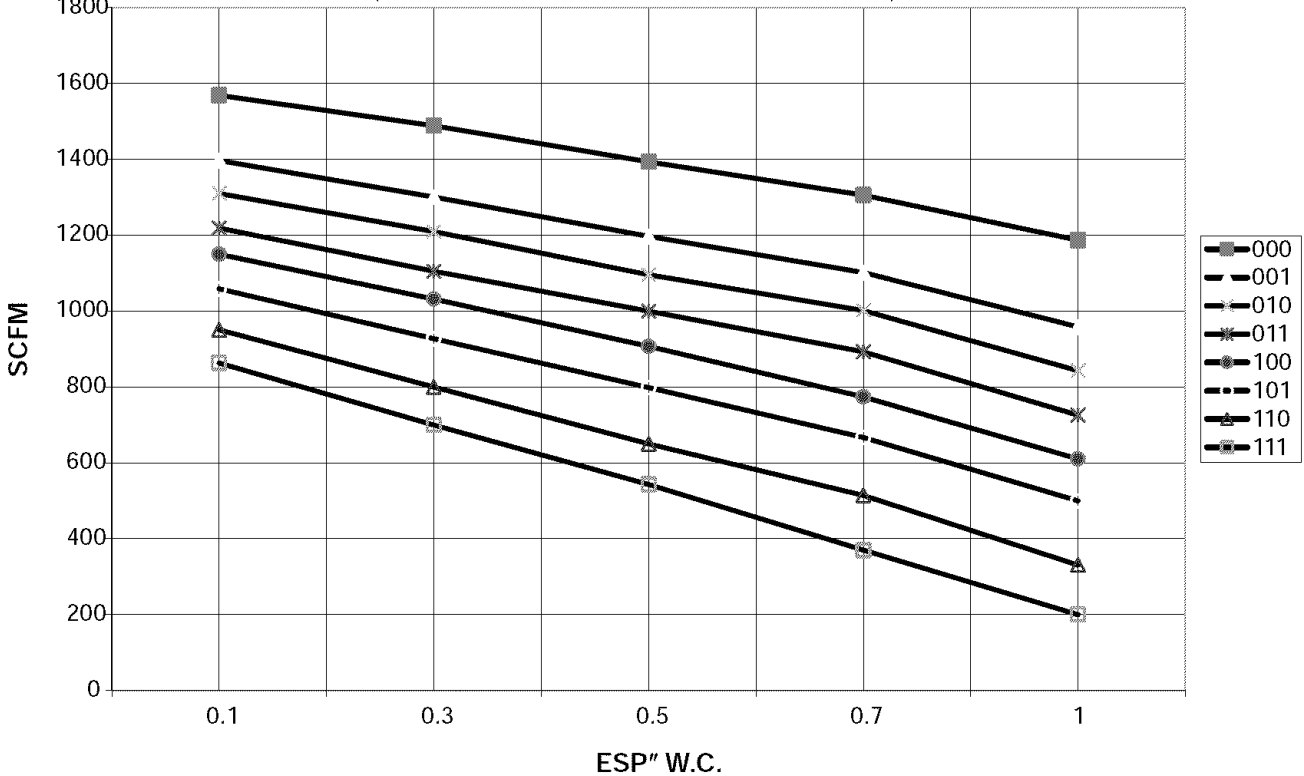

Figure 4

***9MPV075 COOLING**
(CFM VS. EXTERNAL STATIC PRESSURE)



Circulation Air Blower Data - *9MPV

Heating, Cooling & Continuous Airflow Settings

Figure 5

***9MPV075 Hi HEAT**
(CFM VS. EXTERNAL STATIC PRESSURE)

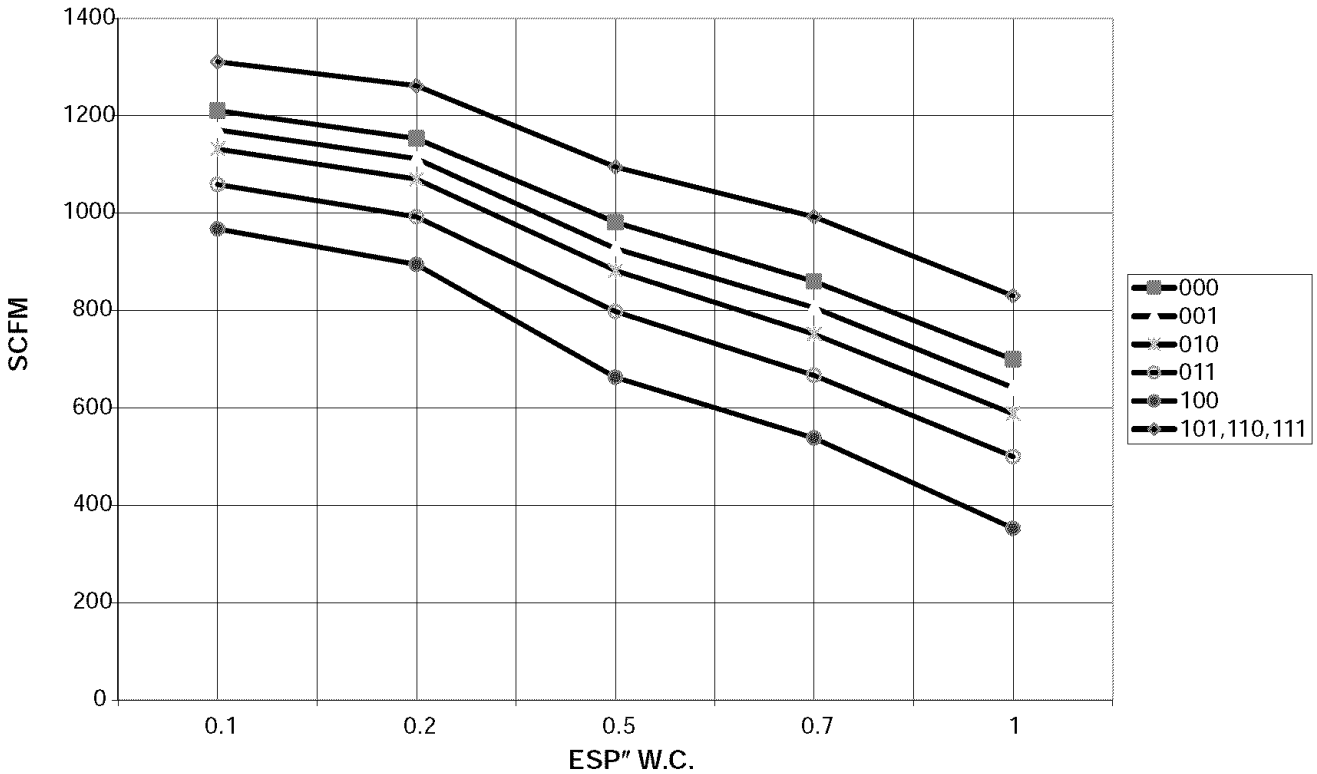
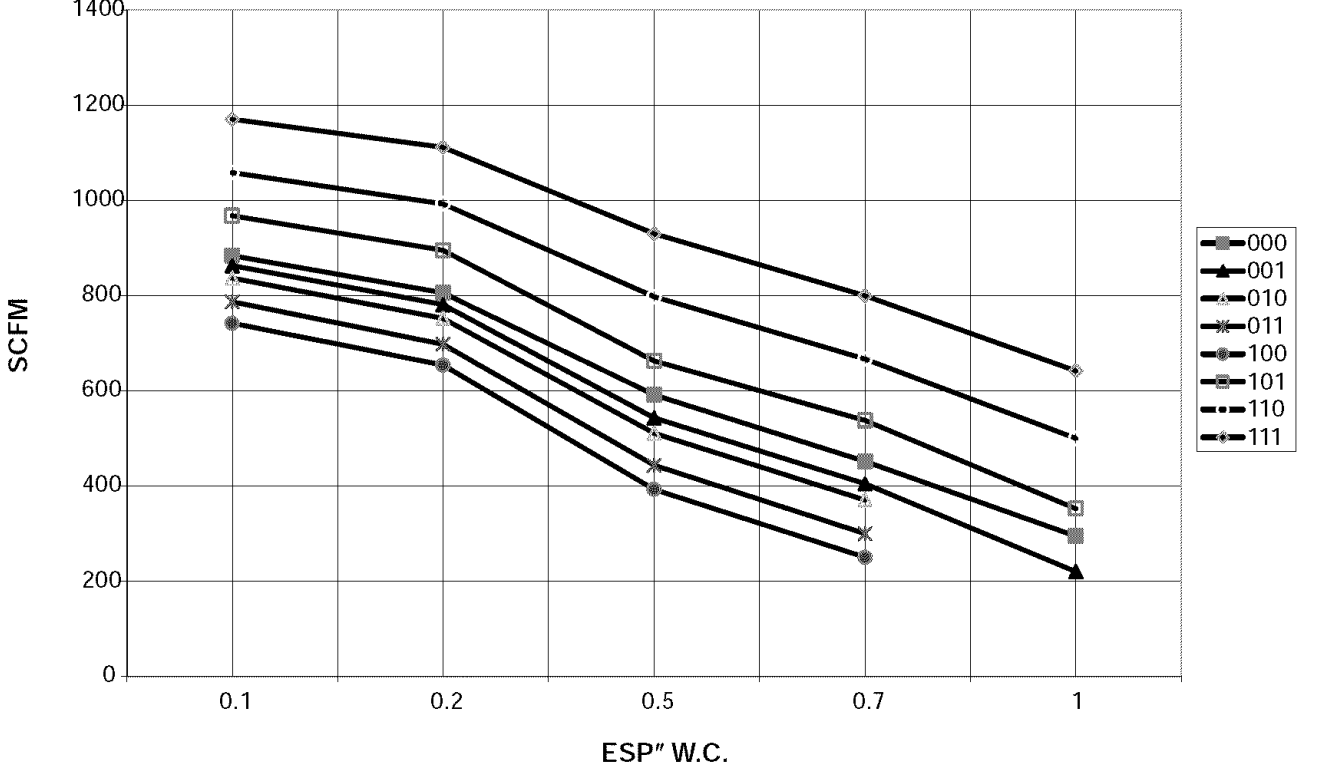

Figure 6

***9MPV075 Lo HEAT**
(CFM VS. EXTERNAL STATIC PRESSURE)



Circulation Air Blower Data - *9MPV

Heating, Cooling & Continuous Airflow Settings

Figure 7

***9MPV100 COOLING**
(CFM VS. EXTERNAL STATIC PRESSURE)

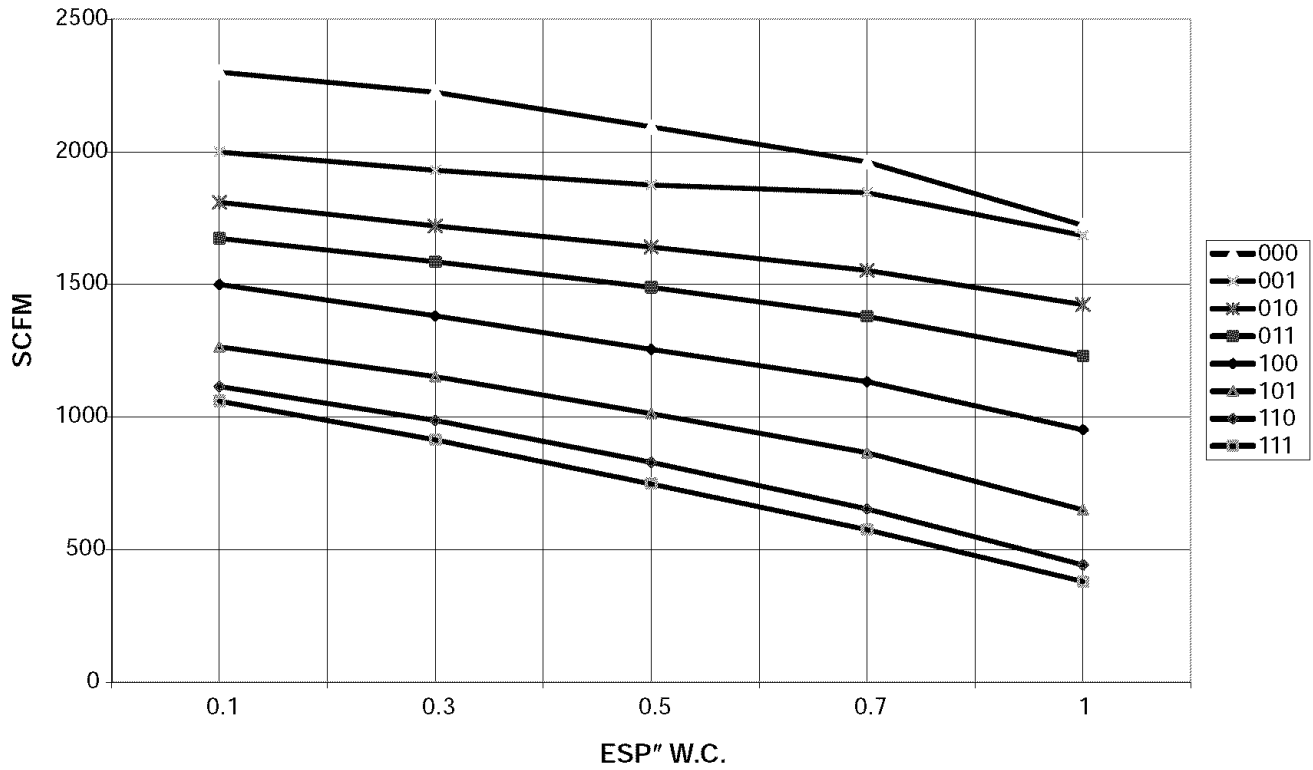
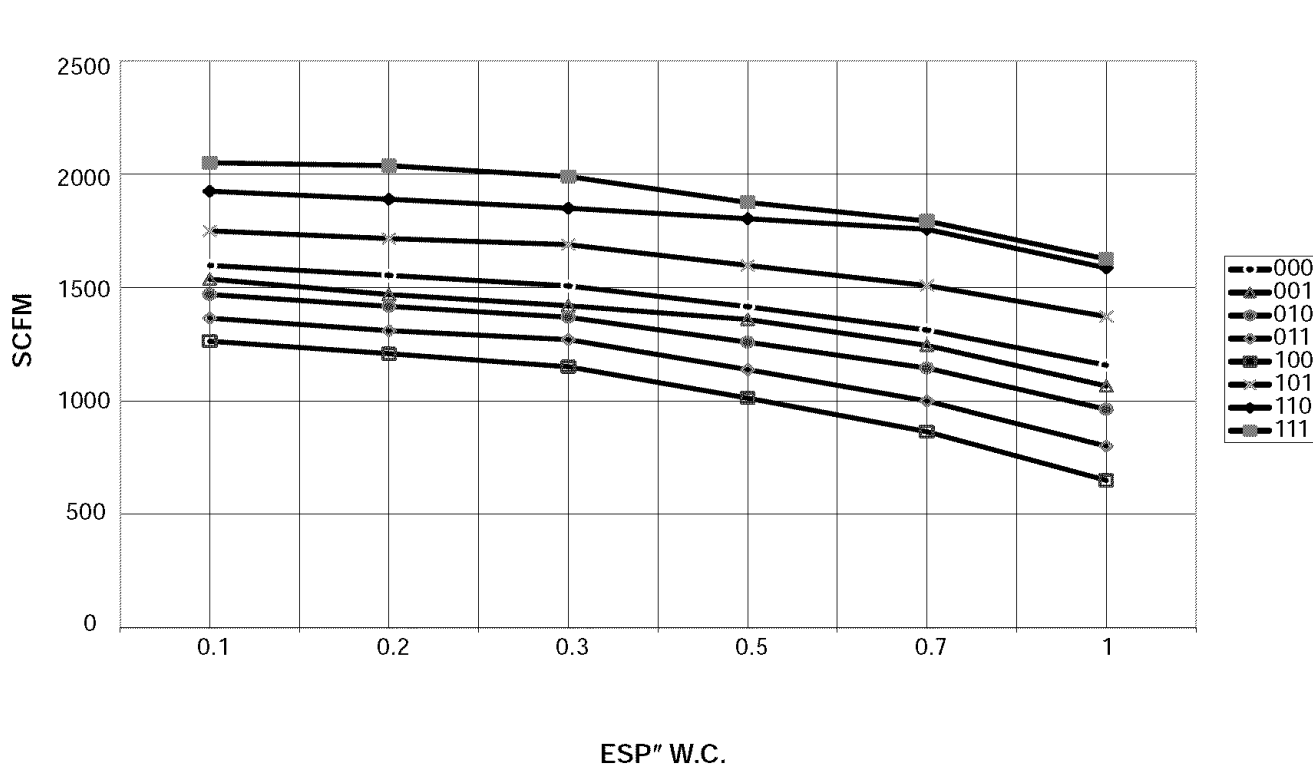

Figure 8

***9MPV100 Hi HEAT**
(CFM VS. EXTERNAL STATIC PRESSURE)



Circulation Air Blower Data - *9MPV

Heating, Cooling & Continuous Airflow Settings

Figure 9

***9MPV100 Lo HEAT**
(CFM VS. EXTERNAL STATIC PRESSURE)

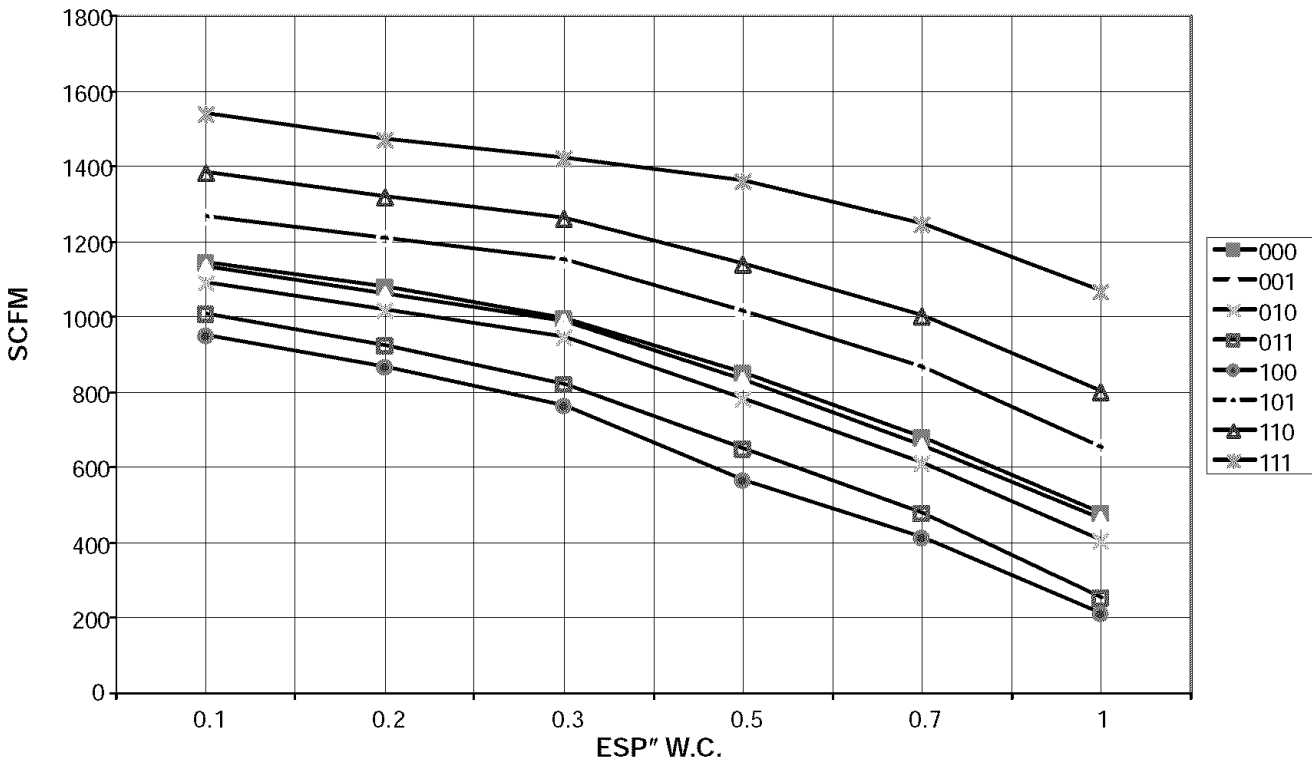
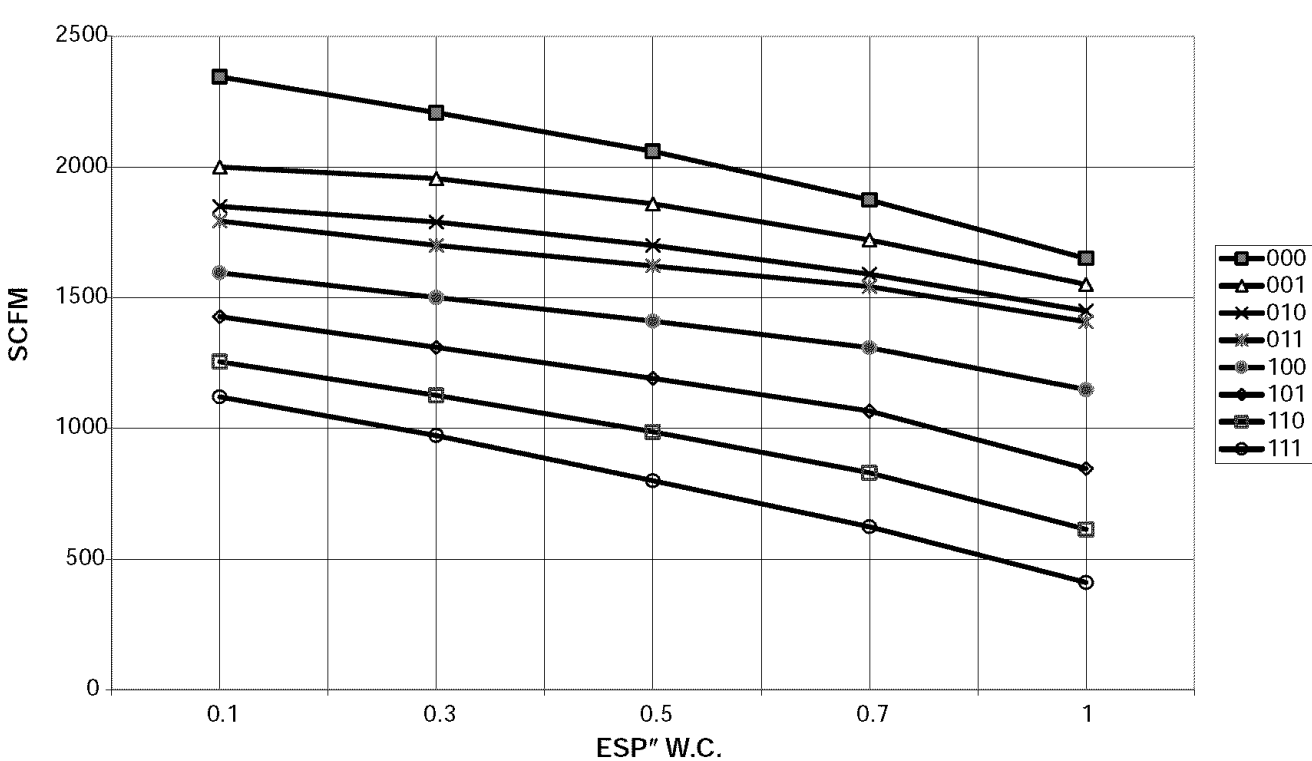

Figure 10

***9MPV125 COOLING**
(CFM VS. EXTERNAL STATIC PRESSURE)



Circulation Air Blower Data - *9MPV

Heating, Cooling & Continuous Airflow Settings

Figure 11

***9MPV125 Lo HEAT**
(CFM VS. EXTERNAL STATIC PRESSURE)

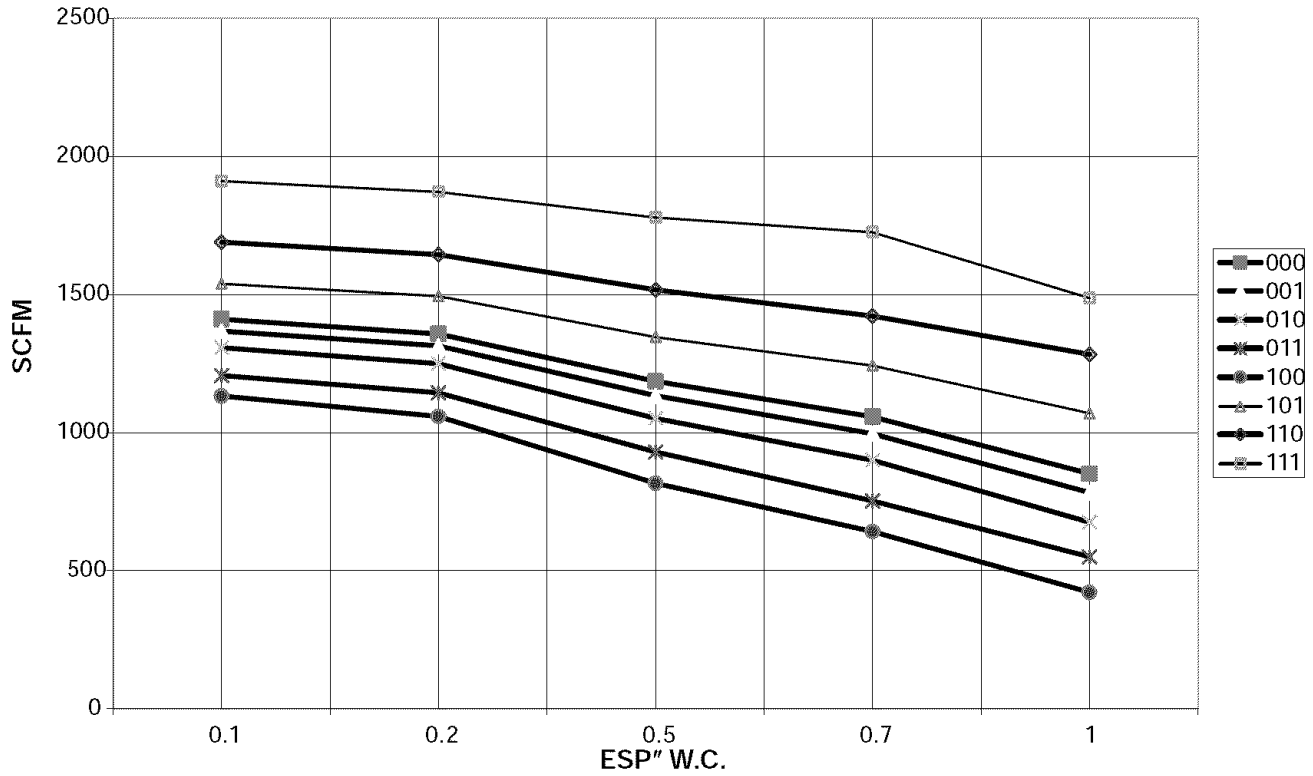
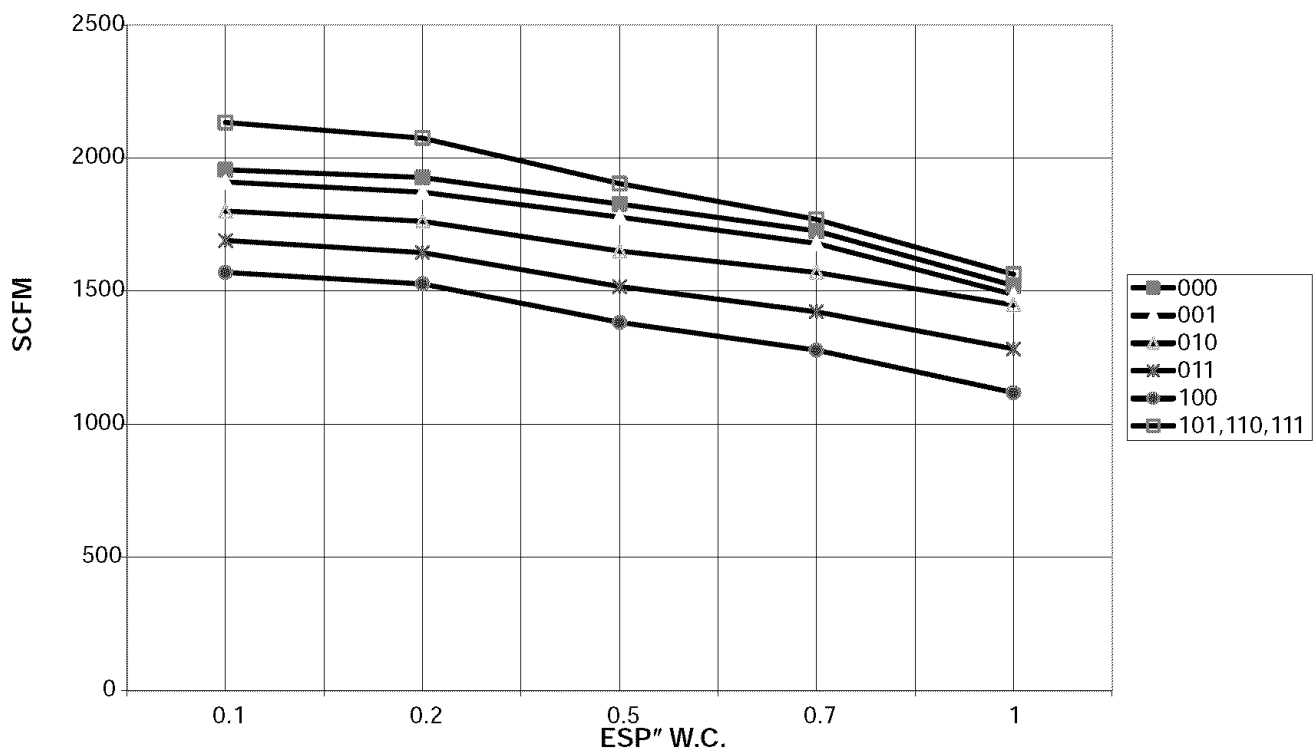
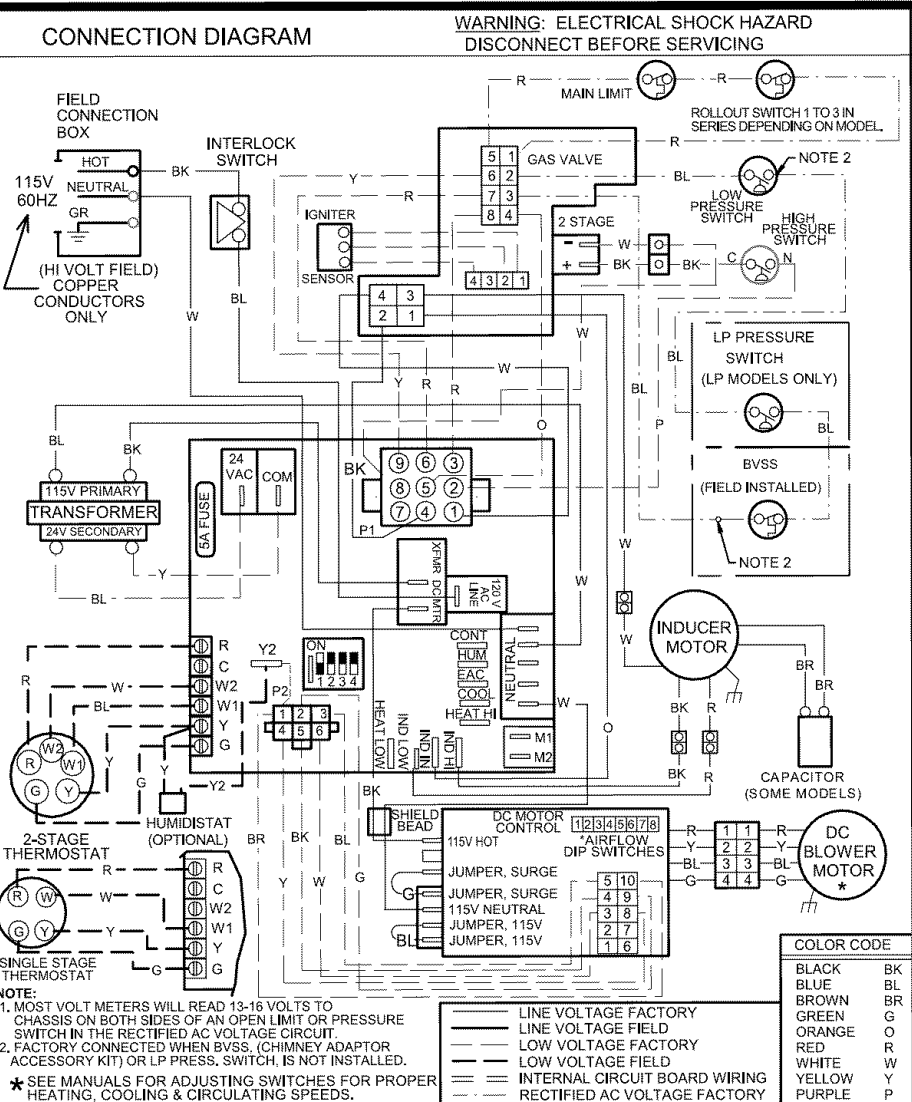
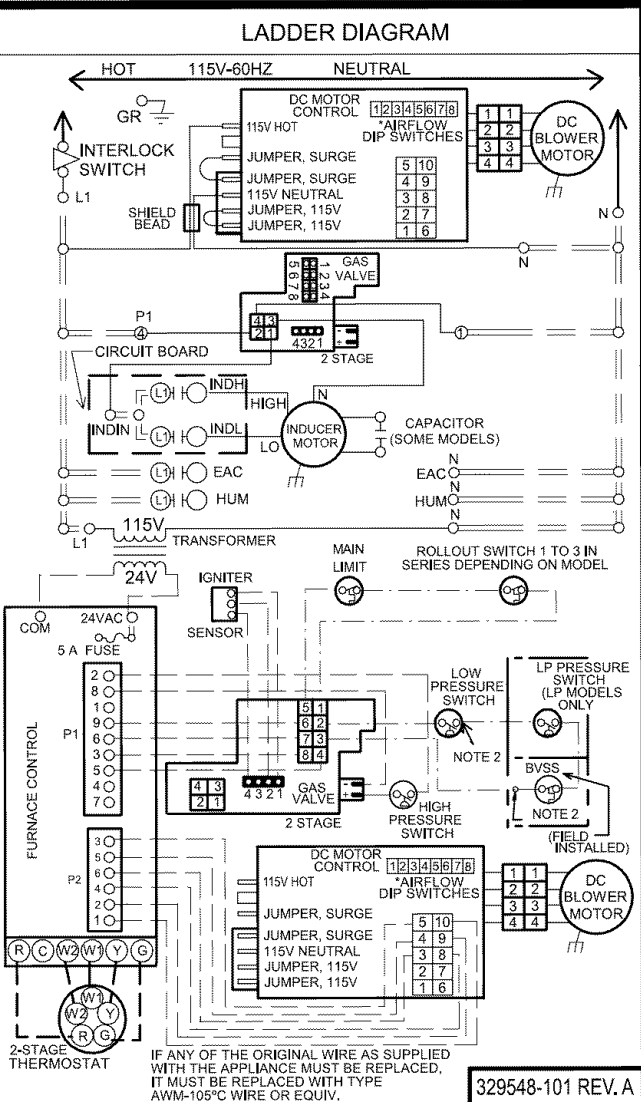
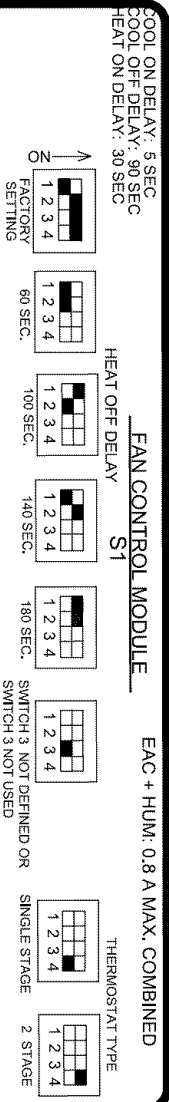

Figure 12

***9MPV125 Hi HEAT**
(CFM VS. EXTERNAL STATIC PRESSURE)



14. Wiring Diagram (1/2 HP Variable Speed Blower Motor)



Wiring Diagram (1 HP Variable Speed Blower Motor)

COOL ON DELAY: 5 SEC
 COOL OFF DELAY: 90 SEC
 HEAT ON DELAY: 30 SEC

FAN CONTROL MODULE S1

EAC + HUM: 0.8 A MAX. COMBINED

THERMOSTAT TYPE

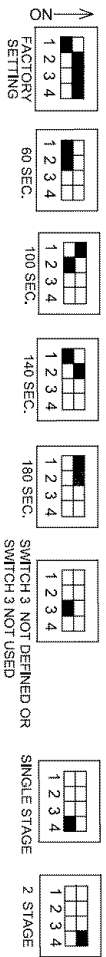

LADDER DIAGRAM

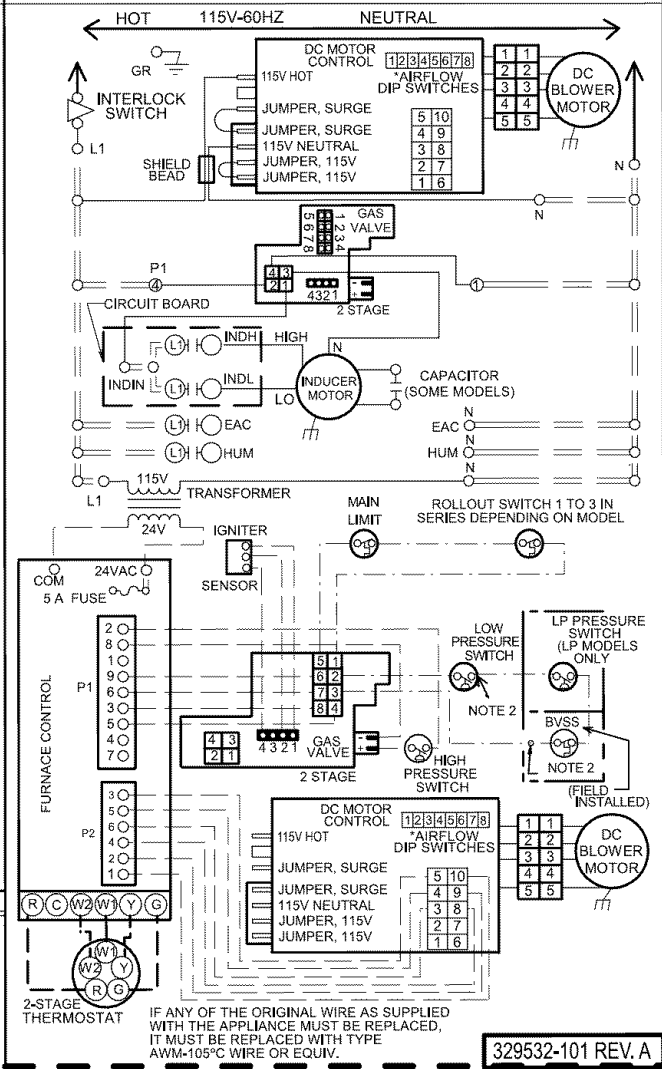

WARNING: ELECTRICAL SHOCK HAZARD DISCONNECT BEFORE SERVICING

CONNECTION DIAGRAM

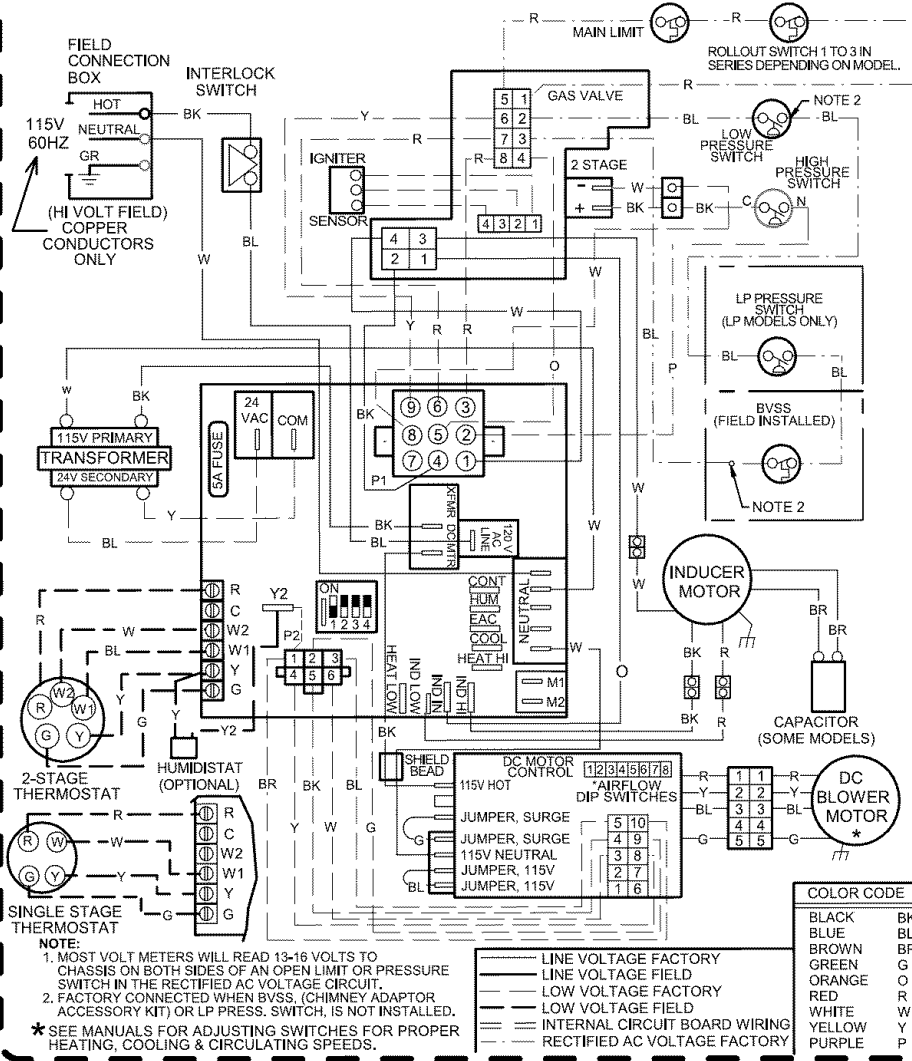

NOTE:
 1. MOST VOLT METERS WILL READ 13-18 VOLTS TO CHASSIS ON BOTH SIDES OF AN OPEN LIMIT OR PRESSURE SWITCH IN THE RECTIFIED AC VOLTAGE CIRCUIT.
 2. FACTORY CONNECTED WHEN BVSS, (CHIMNEY ADAPTOR ACCESSORY KIT) OR LP PRESS. SWITCH, IS NOT INSTALLED.
 * SEE MANUALS FOR ADJUSTING SWITCHES FOR PROPER HEATING, COOLING & CIRCULATING SPEEDS.

329532-101 REV. A

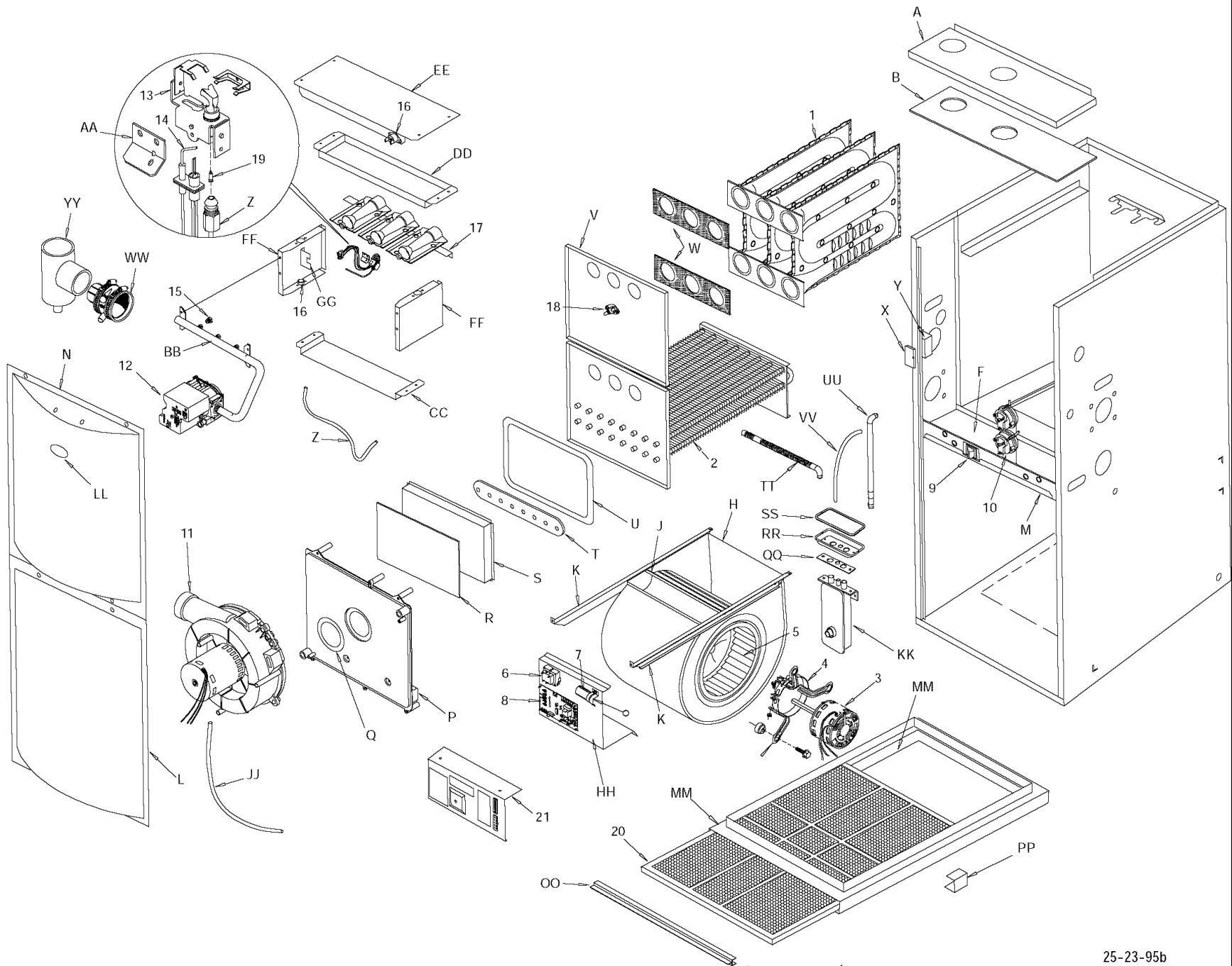

Representative drawing only, some models may vary in appearance.

25-23-95b

Replacement Parts - *9MPV

Models - *9MPV050F12B1, *9MPV075F12B1, *9MPV100J20B1 & *9MPV125L20B1 (Natural Gas)

Replacement part supplied will be current active part. For parts not listed, consult place of purchase.

Key No.	Description Functional	Part Number	*9MPV			
			050 F12B	075 F12B	100 J20B	125 L20B
1	Heat Exchanger, Primary	1012850	1	-	-	-
		1012854	-	1	-	-
		1012858	-	-	1	-
		1012862	-	-	-	1
2	Ht Exchanger, Secondary	1013762	1	-	-	-
		1013763	-	1	-	-
		1013765	-	-	1	-
		1013767	-	-	-	1
3	Motor, Blower	1012478	1	-	-	-
		1012479	-	1	1	1
4	Mount, Motor kit*	1014822	1	1	1	1
5	Wheel, Blower	1013011	1	-	-	-
		1172129	-	1	1	1
6	Transformer	1012722	1	1	1	1
8	Control, Fan Timer	1014459	1	1	1	1
9	Switch, Interlock	1171981	1	1	1	1
10	Switch, Pressure	1013166	-	-	-	1
		1013515	1	1	1	-
11	Blower, Exhaust	1014339	1	1	1	-
		1014340	-	-	-	1
		1013351	1	1	1	1
12	Valve, Gas HSP Nat. 2 Stg	1013351	1	1	1	1
13	Burner, Pilot HSP	1008731	1	1	1	1
14	Igniter/Sensor HSP	1009524	1	1	1	1
15	Orifice, Burner #42 Nat.	1011351	2	3	4	5
16	Switch, Limit (Rollout)	1013102	2	2	2	2
17	Burner Assembly	1008723	1	-	-	-
		1008724	-	1	-	-
		1008725	-	-	1	-
		1008726	-	-	-	1
18	Switch, Limit (Main)	1320366	1	-	-	-
		34335001	-	1	-	-
		34335002	-	-	1	-
		1008445	-	-	-	1
19	Orifice, Pilot .018	503211	1	1	1	1
20	Filter, HH 16X25X1/2"	1010365	1	1	2	2
21	Control, Mtr Variable Spd	1013410	1	-	-	-
		1013411	-	1	-	-
		1013412	-	-	1	-
		1013413	-	-	-	1

Key No.	Description	Part Number	*9MPV				
			050 F12B	075 F12B	100 J20B	125 L20B	
A	Panel, Top	1012866	1	1	-	-	
		1012867	-	-	1	-	
		1012868	-	-	-	1	
B	Gasket, Top Panel	1012603	1	1	-	-	
		1012604	-	-	1	-	
		1012605	-	-	-	1	
F	Partition, Blower	1172008	1	-	-	-	
		1172005	-	1	-	-	
		1172006	-	-	1	-	
		1172007	-	-	-	1	
H	Housing, Blower	1012972	1	-	-	-	
		1012888	-	1	1	1	
J	Panel, Blower Cutoff	721020013	1	-	-	-	
		721020008	-	1	1	1	
K	Hanger, Blower	1012328	2	2	2	2	
L	Door, Blwer (Cmaker only)	1014227	1	-	-	-	
		(Cmaker only)	1014230	-	1	-	-
		(Cmaker only)	1014233	-	-	1	-
		(Cmaker only)	1014236	-	-	-	1
		(Heil only)	1014228	1	-	-	-
		(Heil only)	1014231	-	1	-	-
		(Heil only)	1014234	-	-	1	-
		(Heil only)	1014237	-	-	-	1
M	Bracket Asy., Door Filler	1014229	1	-	-	-	
		(Tstar only)	1014232	-	1	-	-
		(Tstar only)	1014235	-	-	1	-
		(Tstar only)	1014238	-	-	-	1
		1013680	1	1	-	-	
		1013681	-	-	1	-	
1014494	-	-	-	1			
N	Door, Front (Cmaker only)	(Cmaker only)	1014194	1	1	-	-
		(Cmaker only)	1014197	-	-	1	-
		Cmaker only)	1014200	-	-	-	1
		(Heil only)	1014195	1	1	-	-
		(Heil only)	1014198	-	-	1	-
		(Heil only)	1014201	-	-	-	1
		(Tstar only)	1014196	1	1	-	-
		(Tstar only)	1014199	-	-	1	-
1014202	-	-	-	1			
P	Transition Assembly	1012281	1	1	-	-	
		1012282	-	-	1	-	
		1012283	-	-	-	1	
Q	Gasket, Exhaust Blower	1014425	1	1	1	1	
R	Board, Insulating	1012418	1	1	-	-	
		1012419	-	-	1	-	
		1012420	-	-	-	1	
S	Box, Collector	1012244	1	1	-	-	
		1012245	-	-	1	-	
		1012246	-	-	-	1	
T	Gasket, Transition	1013263	1	-	-	-	
		1013080	-	1	-	-	
		1013083	-	-	1	-	
		1013084	-	-	-	1	
U	Gasket, Collector Box	1012594	1	1	-	-	
		1012595	-	-	1	-	
		1012596	-	-	-	1	

*See Table below for bellyband location on motor

Bellyband Location on Motor	
Model *9MPV	A(in.)
050F12B1	1.38"
075F12B1	2.09"
100J120B1	2.09"
125L20B1	2.09"

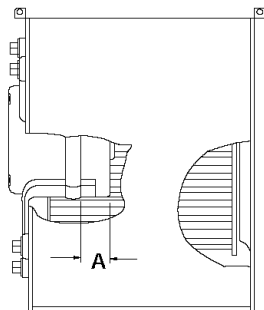

Replacement Parts - *9MPV

Models - *9MPV050F12B1, *9MPV075F12B1, *9MPV100J20B1 & *9MPV125L20B1 (Natural Gas)

Replacement part supplied will be current active part. For parts not listed, consult place of purchase.

Key No.	Description	Part Number	*9MPV				Key No.	Description	Part Number	*9MPV			
			050 F12B	075 F12B	100 J20B	125 L20B				050 F12B	075 F12B	100 J20B	125 L20B
V	Partition, Front Ht Exchger	1012650	1	-	-	-)	PART NOT ILLUSTRATED					
		1012648	-	1	-	-)	Door Screws	1014488	4	4	4	4
		1012651	-	-	1	-)	Door Screw Grommets	1171990	4	4	4	4
		1012653	-	-	-	1)	Coupling, Air Intake	1002284	1	1	1	1
W	Gasket, Attachment Plate	1012542	2	-	-	-)	Gasket, Air Intake	1012583	1	1	1	1
		1012543	-	2	-	-)	Clamp, Hose 5/8"	1012975	4	4	4	4
		1012544	-	-	2	-)	Clamp, Hose 3/4"	1012976	2	2	2	2
		1012545	-	-	-	2)	Coupling, Discharge	1002522	2	2	2	2
X	Cover, Junction Box	1012350	1	1	1	1)	Clamp Hose	1013830	4	4	4	4
Y	Box, Junction	1012349	1	1	1	1)	Grommet, Vent	1012697	1	1	1	1
Z	Tube, Pilot	1012832	1	-	1	-)	Bushing, Strain Relief	1945287	1	1	1	1
		1013189	-	1	-	-)	Grommet, Vinyl (Gas Inlet)	1009535	1	1	1	1
		1013077	-	-	-	1)	Harness, Wire	1013689	1	1	-	-
AA	Bracket, Pilot	1010901	1	1	1	1)	1013690	-	-	1	1	
BB	Manifold	1012970	1	-	-	-)	Harness, Wire Lo Voltage	1012520	1	1	1	1
		1012971	-	1	-	-)	Harness, Wire High Voltage	1012521	1	1	1	1
		1012278	-	-	1	-)	Trap, Drain Tee	1171916	1	1	1	1
		1012279	-	-	-	1)	Tube, Drain 1/2" ID Drain	1171991	1	1	1	1
CC	Bottom, Burner Box	1012334	1	1	-	-)	Tube, 1/2" Elbow	1171992	2	2	2	2
		1012335	-	-	1	-)	Coupling, 1/2" Barbed	1171993	1	1	1	1
		1012336	-	-	-	1)	Tubing, 5/8" ID Drain	1171994	1	1	1	1
DD	Baffle, Burner Box	1012338	1	1	-	-)	Connector, 3/4" X 1/2"	1171995	1	1	1	1
		1012339	-	-	1	-)	Elbow, 1/2" CPVC street	1171996	1	1	1	1
		1012340	-	-	-	1)	Grommet, Casing	1170977	1	1	1	1
EE	Top, Burner Box	1013702	1	1	-	-)	Tube, Relief Ext.	1009238	1	1	1	1
		1013703	-	-	1	-)	Connector, Relief Tube	1171998	1	1	1	1
		1013704	-	-	-	1)	Plate, Cover	1171999	1	1	1	1
FF	Bracket, Manifold Support	1012377	2	2	2	2)	Gasket, Cover Plate	1172000	1	1	1	1
GG	Bracket, Burner Box Side	1012532	2	2	2	2)	Cap, Drain Tee	1172001	1	1	1	1
HH	Bracket, Control Mounting	1012321	1	1	1	1)	Clamp, Tee Cap	1172002	1	1	1	1
JJ	Tube, Sensor	1009238	1	1	1	1)	Manual, Users	44102201003	1	1	1	1
KK	Trap, Drain Assembly	1171917	1	1	1	1)	Manual, Installation	44001202004	1	1	1	1
LL	Sightglass (Tstar only)	1013235	1	1	1	1)						
		1013236	1	1	1	1)						
MM	Wrapper, Filter Rack	741010039	1	1	2	2	Gas Conversion Kits - All models						
NN	Front, Filter Rack	741020001	1	1	2	2	Nat to LP *1011789						
OO	Cover, Filter	2791043	1	1	2	2	LP to Nat *1011787						
PP	Clip, Filter	1008482	3	3	3	3	* Must be ordered from Service Parts						
QQ	Gasket, Trap	1013701	1	1	1	1							
RR	Bracket, Trap	1171986	1	1	1	1							
SS	Bracket, Trap Bracket	1171987	1	1	1	1							
TT	Tube, Drain Coll. Box 5/8" ID	1171988	1	1	1	1							
UU	Tube, Drain Tee 1/2" ID	1171989	1	1	1	1							
VV	Tube, Relief	1009238	1	1	1	1							
WW	Drain Vent	1014003	1	1	1	1							
YY	Tee, Drain	1171915	1	1	1	1							