

# BOSCH

## USE AND CARE MANUAL

for

### GAS COOKTOPS

with FULL SURFACE GRATES

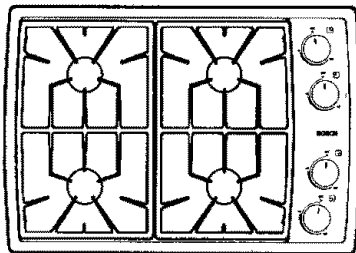

**30" MODELS  
NGT73, NGP73**

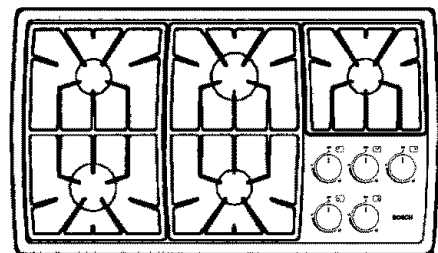

**36" MODELS  
NGT93, NGP93**

**To the Installer:** Leave this manual with the cooktop.  
**To the Consumer:** Retain this manual for future reference

## Dear Bosch Cooktop Owner

Thank you and congratulations on your purchase of a Bosch cooktop. Whether you are an expert chef or a beginning cook we believe that you will find your Bosch cooktop exceeds your expectations for a modern gas cooktop. You will take great pride in the quality of construction of these fine cooktops.

We also ask that you read this manual thoroughly before using your new cooktop. This is especially important if you have never before used a gas cooktop. Please pay particular attention to the Safety Instructions printed at the front of the book and the numerous safety hints and cautions placed throughout this manual. Also, be sure to familiarize yourself with the proper operation of the cooktop and its cleaning and maintenance procedures. Adherence to these instructions and procedures will assure that you realize the full potential of your new cooktop.

For even more information visit our website at [www.boschappliances.com](http://www.boschappliances.com) to learn about your cooktop as well as other top quality Bosch appliances. If you have any questions, please contact us at 1-800-944-2904. For additional information, write to us at:

BOSCH  
BSH Home Appliances Corp.  
5551 McFadden Avenue  
Huntington Beach, CA 92649

Note: The **Bosch** cooktop referred to throughout this manual is manufactured by BSH Home Appliances Corp.

# Table of Contents

**Safety Instructions** ..... 1-2

**Operating Instructions**

- Features of Your Cooktop ..... 3
- Sealed Burners ..... 4
- Burner Caps ..... 4
- Grates ..... 4
- Burner Control Knobs ..... 4-5
- Electronic Ignition/Reignition ..... 5
- Typical Flame Characteristics ..... 5
- Power Failure ..... 5
- Proper Cookware ..... 6
- Cooking Chart ..... 7

## Care and Cleaning

- Cleaning the Cooktop ..... 8
- Cooktop Cleaning Chart ..... 8-9

## Problem Solver

- In Case of a Power Failure ..... 5
- Before Calling for Service ..... 10

## Consumer Services

- Warranty ..... 11
- How to Obtain Service ..... 10
- Data Plate Information ..... Back Cover



## IMPORTANT SAFETY INSTRUCTIONS

Read all instructions before using this appliance.



### WARNING:

If the information in this manual is not followed exactly, a fire or explosion may result causing property damage, personal injury or death.

Do not store or use gasoline or other flammable vapors and liquids in the vicinity of this or any other appliance.

#### WHAT TO DO IF YOU SMELL GAS:

- Do not try to light any appliance.
- Do not touch any electrical switch.
- Do not use any phone in your building.
- Immediately call your gas supplier from a neighbor's phone. Follow the gas supplier's instructions.
- If you cannot reach your gas supplier, call the fire department.

Installation and service must be performed by a qualified installer, authorized service agency or the gas supplier.

## COOKTOP SAFETY



**WARNING** – To reduce the risk of fire, electric shock, or injury to persons, take these precautions:

- This appliance is intended for normal family household use only. See the Warranty. If you have any questions, contact the manufacturer.
- Have the cooktop installed and grounded by a qualified technician. Have the installer show you where the gas shut-off valve is located.
- Do not repair or replace any part of the appliance unless specifically recommended in this manual. All other servicing should be referred to a qualified technician.
- For proper lighting and performance of the burners, keep the igniters clean and dry.
- In the event that a burner goes out and gas escapes, open a window or a door. Wait at least 5 minutes before using the cooktop.
- Do not obstruct the flow of combustion and ventilation air.
- Do not use aluminum foil to line any part of the cooktop.
- If the cooktop is near a window, be certain that curtains or any other window covering do not blow over or near the burners; they could catch on fire.



# IMPORTANT SAFETY INSTRUCTIONS



Read all instructions before using this appliance.

## PERSONAL SAFETY



**WARNING — TO REDUCE THE RISK OF INJURY TO PERSONS, IN THE EVENT OF A GREASE FIRE, OBSERVE THE FOLLOWING:**

- In the event of a grease fire **SMOTHER FLAMES** with a close-fitting lid, cookie sheet, or other metal tray, then turn off the gas burner. **BE CAREFUL TO PREVENT BURNS.** If the flames do not go out immediately, **EVACUATE AND CALL THE FIRE DEPARTMENT.**
- Do not use water, including wet dishclothes or towels on grease fires. A violent steam explosion may result.
- **NEVER PICK UP A FLAMING PAN.** You may be burned.
  - **ALWAYS** have a working **SMOKE DETECTOR** near the kitchen.
  - **LEAVE THE HOOD VENTILATOR ON** when flambéing food.
- Use an extinguisher **ONLY IF**:
  - You know you have a Class ABC extinguisher, and you already know how to operate it.
  - The fire is small and contained in the area where it started.
  - The fire department is being called.
  - You can fight the fire with your back to an exit.
- **SMOTHER FLAMES** from other types of food fires with baking soda. **NEVER** use water on cooking fires.



**WARNING — TO REDUCE THE RISK OF BURN INJURIES DURING COOKTOP USE, OBSERVE THE FOLLOWING:**

- Never use the cooktop to warm or heat a room.
- **Children or pets should not be left alone or unattended in an area where appliances are in use.** They should never be allowed to sit or stand on any part of the appliance.
- **CAUTION: Do not store items of interest to children above or at the back of the cooktop .**
- **Do not store flammable materials on or near the cooktop.**

- When using the cooktop: **DO NOT TOUCH THE BURNER GRATES OR THE IMMEDIATE SURROUNDING AREA.**
- **Use only dry potholders;** moist or damp potholders on hot surfaces may cause burns from steam.
- **Never leave the cooktop unattended when in use.** Boilovers cause smoking, and greasy spillovers may ignite. A spill on a burner can smother all or part of the flame or hinder spark ignition. If a boilover occurs, turn off burner and check operation. If burner is operating normally, turn it back on.
- During cooking, **set the burner control so that the flame heats only the bottom of the pan** and does not extend beyond the bottom of the pan.
- Take care that drafts like those from fans or forced air vents **do not blow flammable material toward the flames or push the flames so that they extend beyond the edges of the pan.**
- **Always position handles of utensils inward** so they do not extend over adjacent work areas, burners, or the edge of the cooktop.
- **Wear proper apparel.** Loose fitting garments or hanging sleeves should never be worn while cooking.
- In the event that personal clothing catches fire, **DROP AND ROLL IMMEDIATELY** to extinguish flames.
- **Never let clothing, potholders, or other flammable materials come in contact with hot burners or hot burner grates.**
- **Use only certain types of glass, heatproof glass-ceramic, ceramic, earthenware, or other glazed utensils that are suitable for cooktop use.**
- **Do not clean the cooktop while it is still hot.** Some cleaners produce noxious fumes when applied to a hot surface.
- **CAUTION: Do not allow aluminum foil, plastic, paper or cloth to come in contact with a hot burner or grate. Do not allow pans to boil dry.**

**California Proposition 65** - Warning: Burning gas cooking fuel generates some by-products which are on the list of substances which are known by the State of California to cause cancer or reproductive harm. To minimize exposure to these substances, always operate this unit according to the instructions contained in this booklet and provide good ventilation.

# FEATURES OF YOUR COOKTOP

## 30" Models

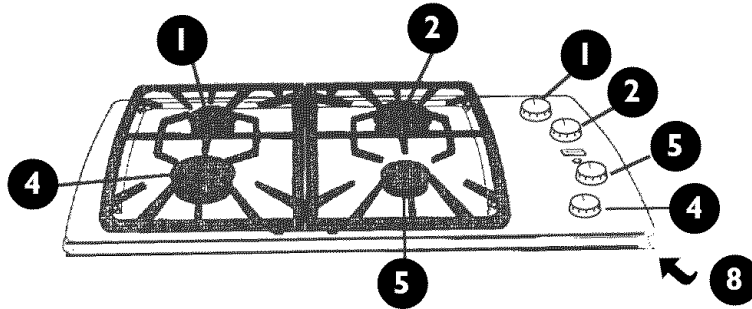

## 36" Models

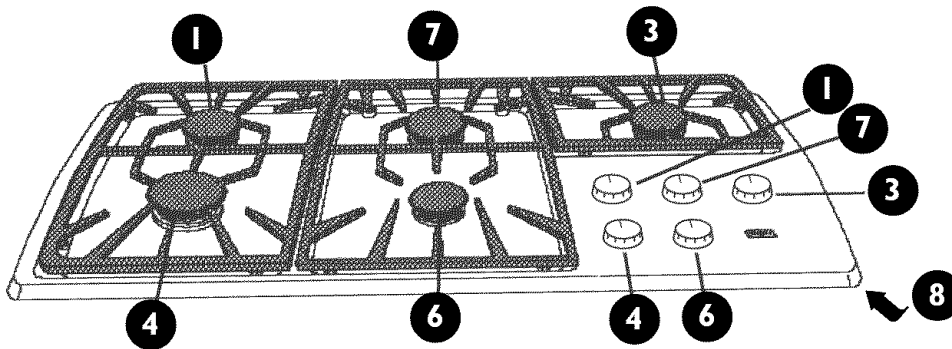

KEY NO*	LOCATION	BTU RATE
1	Left Rear	9,100
2	Right Rear-30"	11,000
3	Right Rear-36"	9,100
4	Left Front	12,500 - NGT Model 15,000 - NGP Model
5	Right Front-30", Simmer Burner	6,500/950
6	Center Front-36", Simmer Burner	6,500/950
7	Center Rear-36"	11,000
8	Serial/Number/Data Plate	

\* Key numbers 1-7 also correspond to the control knob location for the burner.

# COOKTOP OPERATION

The following pages explain how each feature on the gas cooktop works and how to get the best cooking results.

Follow these hints when cooking on the cooktop:

- Use proper cookware. (See Page 6.)
- Center the pan over the burner before turning the burner on.
- Refer to the Cooking Chart on Page 7 for suggested flame settings.

## Sealed Burners

Your new cooktop has sealed gas burners. There are no burner parts under the cooktop to clean, disassemble or adjust. Your cooktop has two different burner cap sizes, large and medium. Match the pan to the size burner.

## Burner Caps

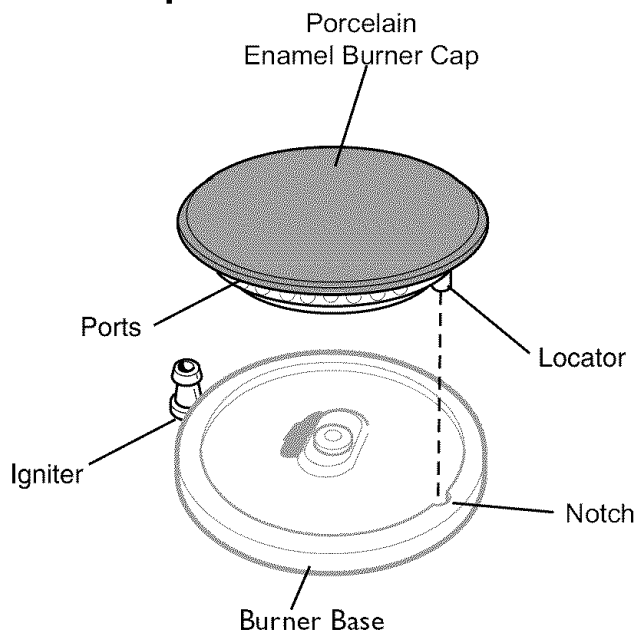

The burner cap is porcelainized steel. On the underside of the cap is one locator which must fit into the corresponding notch on the burner base. If the burner cap is not placed correctly, the burner may not light or the flame may not burn completely or correctly.



**WARNING:** To prevent flare-ups do not use the cooktop without all burner caps and all burner grates properly positioned.

## Burner Grates

The position of each double grate is labeled on the underside edge of the grate as shown in the figure below.

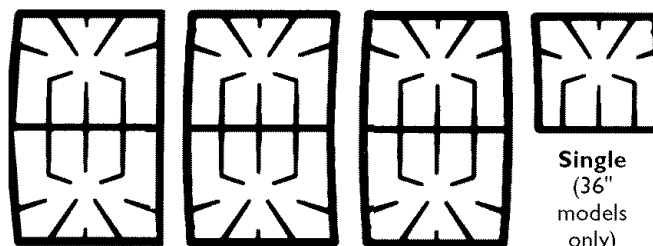

**Universal**  
(30" models only)

**Side**

**Center**

**30" Models** have two universal grates. Position the straight side in the center. They are interchangeable by rotating 180°.

**36" Models** have one side grate, one center grate and one single grate. Position the grates on the cooktop as illustrated above.



**WARNING:** To prevent flare-ups all grates must be properly positioned on the cooktop whenever the cooktop is in use. Each of the four feet must be placed into the corresponding dimples in the cooktop. See illustration on Page 8. Do not use a grate if the rubber feet are missing or damaged.

## Burner Control Knobs

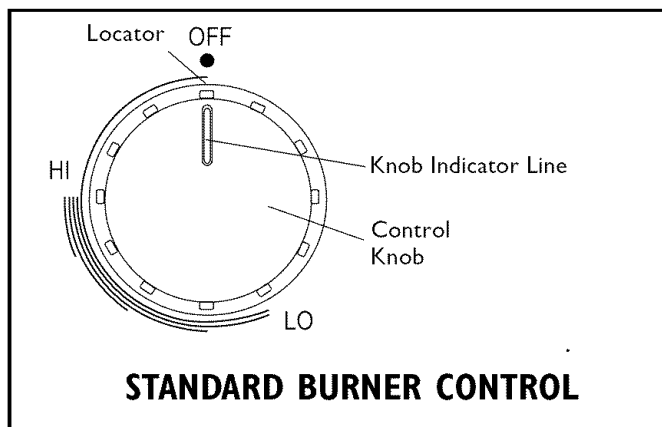

# COOKTOP OPERATION

## Burner Control Knobs (continued)

The standard burner controls have an infinite number of heat settings with no fixed positions.

To operate: Select the appropriate control knob, push down and turn counterclockwise to the desired flame size. Turn OFF by turning the control knob clockwise to OFF.

A rubber grommet is located under each control knob.

**To remove knob and grommet:** With burner in the OFF position, gently lift knob up and off. Gently pull grommet toward center and lift out.



**WARNING:** To avoid electric shock, do not reach through opening into rough-in box.

To replace grommet and knob: Replace grommet by placing center groove around cooktop. The rubber grommet should be firmly attached around the cooktop opening. Place the control knob indicator line at the OFF position; press down firmly.

## Electronic Ignition/Reignition

The cooktop uses electronic igniters to light the burners. There is no pilot light. Each burner has its own igniter. If a burner flame blows out during use, the burner will automatically reignite.

**CAUTION:** All igniters spark when any single burner is turned ON or the reignition system is activated. Do not touch any of the burners when the cooktop is in use.

The ignitor should be clean and dry for proper operation.

- Avoid getting water or food on the igniter.
- If the igniter is wet or soiled, it may spark without igniting the burner, or even spark continuously when a flame is present.

**Note:** If the burner does not light within 4 seconds, turn the burner off. Check to see that the cap is positioned correctly on the burner base and the igniter is clean and dry. If a burner still fails to ignite, see *Before Calling for Service* on Page 10.

## Typical Flame Characteristics

The burner flame should be blue in color and stable with no yellow tips, excessive noise or fluttering. It should burn completely around the burner cap.

Foreign particles in the gas line may cause an orange flame during initial use. This should disappear with use. Check burner cap to make sure port holes are not obstructed. If the ports are clogged, see *Before Calling for Service* on page 10.

**Note:** An audible “pop” may be heard when the burner is turned off manually. The “popping” may be louder with LP gas than with natural gas. This is normal.

## Power Failure

In the event of a power failure, the burners can be ignited manually.

If the cooktop is being used when a power failure occurs, turn all the burner control knobs to the **OFF** position. The burners can then be ignited manually by holding a match at the ports and turning the control knob to the HI position. Wait until the flame is burning all the way around the burner before adjusting the flame to the desired height.

**CAUTION:** The reignition feature will not work in the event of a power failure.

# PROPER COOKWARE

## Cookware Characteristics

- Aluminum or copper bottomed pans conduct heat evenly.
- Steel pans, if not combined with other metals, may cook unevenly.
- Cast-iron cookware absorbs heat slowly and cooks more evenly at low-to-medium settings.
- Flat, heavy bottom pans provide even heat and stability.

DO NOT USE pans that are thin, warped, dented or ridged as they heat unevenly.

### Match Pan Diameter to Flame Size

- The flame should be the same size as the bottom of the pan or smaller. Do not use small pans with high flame settings as the flames can lick up the sides of the pan.
- Oversize pans that span two burners are placed front to rear, not side to side.



### Use Balanced Pans

- Pans must sit level on the cooktop grate without rocking.
- Center pan over burner.



### Use a Lid That Fits Properly

- A well-fitting lid helps shorten the cooking time.



**Pans that span 2 burners**, i.e. griddles, roasters and fish poachers, may be used when placed front to back. Adjust flame equally to cook evenly. Use the Bosch accessory griddle on your Bosch Cooktop. To order, call the 800 number listed below.

**Use a wok with a flat bottom.** If using a round bottomed wok, use the Bosch accessory support wok ring. To order call the 800 number listed below.

For simmering stews and soups, or melting chocolate, use the **Bosch simmer plate accessory**. The simmer plate distributes the heat evenly and gently. The simmer plate is supplied with NGP models only, but is available separately for the NGT. Follow use and care instructions provided with the simmer plate.

**Canners and pressure cookers** must meet the same requirements as described above.

- After bringing contents to a boil, use lowest heat setting possible to maintain a boil or pressure (for pressure canners/cookers).

**Bosch Customer Service — 800/944-2904**



# COOKING CHART

FOOD	Start Cooking	Continue Cooking
<b>BREADS</b> French Toast, Pancakes Grilled Sandwiches	<b>Med.</b> – preheat skillet.	<b>Med. LO to Med.</b>
<b>CEREALS</b> Cornmeal, Grits, Oatmeal	<b>HI</b> – cover, bring water to a boil, add cereal.	<b>Med. LO to Med.</b> – finish cooking according to package directions.
<b>CHOCOLATE</b>	<b>LO</b> to melt.	Remove when melted.
<b>DEEP FRYING</b>	<b>HI</b> – heat oil	<b>Med. HI to HI</b> – to maintain temperature.
<b>EGGS</b> Cooked in Shell	<b>HI</b> – cover, bring water to a boil, add eggs, cover.	<b>OFF to LO</b> – cook 3 to 4 minutes for soft cooked; or 15 to 20 minutes for hard cooked.
Fried, Scrambled	<b>Med. to Med. HI</b> – melt butter, add egg.	<b>LO to Med. LO</b> finish cooking.
<b>MEAT, FISH, POULTRY</b> Bacon, Sausage Patties	<b>HI</b> – until meat starts to sizzle.	<b>Med. LO to Med.</b> – to finish cooking.
<b>Braising:</b> Swiss Steak, Pot Roast	<b>HI</b> – melt fat, then brown on <b>Med. HI</b> to <b>HI</b> , add liquid, cover.	<b>LO to Med. LO</b> – cover, simmer until tender.
<b>Frying:</b> Chicken	<b>HI</b> – melt fat, then brown on <b>Med.</b>	<b>LO</b> – cover, finish cooking.
<b>Pan Frying:</b> Lamb Chops, Thin Steaks, Hamburgers, Link Sausage	<b>Med. HI to HI</b> – preheat skillet.	<b>Med. to HI</b> – brown meat.
<b>Simmering:</b> Stewed Chicken, Corned Beef, Poaching Fish	<b>HI</b> – cover, bring liquid to a boil.	<b>LO to Med. LO</b>
<b>POPCORN</b>	<b>Med to Med. HI</b> – cover, heat until kernels start to pop.	<b>Med. to Med. HI</b> – finish popping.
<b>PRESSURE COOKER</b> Meat, Vegetables	<b>Med. HI to HI</b> – build up pressure.	<b>Med. LO to Med.</b> – maintain pressure.
<b>RICE</b>	<b>HI</b> – cover, bring water to boil, add rice, cover.	<b>LO to Med. LO</b> – cover, cook according to package directions.
<b>SAUCES</b> Tomato Base	<b>Med. HI to HI</b> – cook meat/vegetables, follow recipe.	<b>LO to Med. LO</b>
White, Cream, Bernaise, Hollandaise	<b>LO to Med. LO</b> – melt fat, follow recipe.	<b>LO to Med. LO</b> – finish cooking.
<b>SOUPS, STEWS</b>	<b>HI</b> – cover, bring liquid to a boil.	<b>LO to Med. LO</b> – simmer.
<b>STIR FRY</b>	<b>HI</b> – heat oil, add vegetables.	<b>Med. HI to HI</b> – finish cooking.
<b>VEGETABLES</b> Fresh	<b>HI</b> – cover, bring water and vegetable to a boil.	<b>Med. LO to Med.</b> – cook 10 to 30 minutes, or until tender.

# CLEANING THE COOKTOP

The entire Cooktop can be safely cleaned by wiping with a soapy sponge, then rinsing and drying. If stubborn soil remains, follow the recommended cleaning methods below.

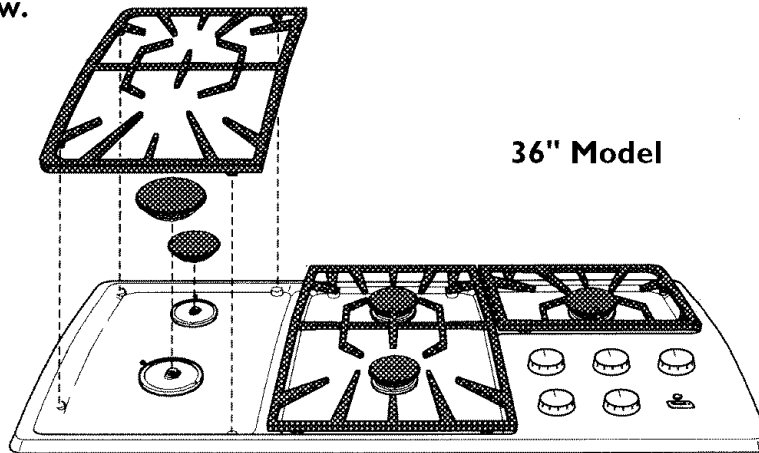

## CAUTION:

- Before cleaning, be certain the burners are turned off and the grates are cool.
- Always use the mildest cleaner that will do the job. Use clean, soft cloths, sponges or paper towels.
- Rub stainless steel finishes in the direction of the grain. Wipe area dry to avoid water marks.
- Do not clean removable cooktop parts in any self-cleaning oven.
- After cleaning, place all parts in their proper positions before using cooktop.

*The cleaners recommended below and on the following page indicate cleaner types and do not constitute an endorsement of a particular brand. Use all products according to package directions.*



**WARNING:** To avoid electrical shock hazard: If cleaning under the cooktop is ever required, switch off main power before reaching inside.

## Cooktop Cleaning Chart

Cooktop Part / Material	Suggested Cleaners	Important Reminders
<b>Burner Base and Burner Cap, underside</b> Aluminum Alloy	<ul style="list-style-type: none"> <li>• Detergent and hot water; rinse and dry.</li> <li>• Stiff nylon bristle-toothbrush to clean port openings.</li> <li>• Abrasive cleansers: Brillo® or S.O.S.® pads. Rinse and dry.</li> </ul>	<ul style="list-style-type: none"> <li>• Do not soak burner caps.</li> <li>• Do not scratch or gouge the port openings.</li> <li>• Clean ports with a wire or straightened paper clip.</li> <li>• Do not use a toothpick that may break off.</li> </ul>
<b>Burner Cap and exterior finish</b> Porcelain Enamel	<ul style="list-style-type: none"> <li>• Hot sudsy water; rinse and dry thoroughly.</li> <li>• Nonabrasive cleansers: Ammonia, Fantastic®, Formula 409®.</li> <li>• Mild abrasive cleansers: Bon Ami®, Ajax®, Comet®.</li> <li>• Liquid cleaners: Kleen King®, Soft Scrub®.</li> <li>• Stiff nylon bristle toothbrush to clean port openings.</li> <li>• Reassemble. Make sure that the cap is seated on the base and aligns with the notch.</li> </ul>	<ul style="list-style-type: none"> <li>• Acidic and sugar-laden spills deteriorate the porcelain enamel. Remove soil immediately.</li> <li>• Do not use wet sponge or towel on hot porcelain.</li> <li>• Do not soak burner caps.</li> <li>• Always apply minimal pressure with abrasive cleaners.</li> </ul>

*Continued, please turn page*

## Cooktop Cleaning Chart, *continued from previous page*

Cooktop Part / Material	Suggested Cleaners	Important Reminders
<b>Control Knobs</b> / Plastic	<ul style="list-style-type: none"> <li>• Hot sudsy water; rinse and dry immediately.</li> <li>• To remove knobs, lift straight up.</li> </ul>	<ul style="list-style-type: none"> <li>• See Warning page 8.</li> <li>• Do not soak knobs.</li> <li>• Do not force knobs onto valve shaft.</li> <li>• Do not use abrasive scrubbers or cleansers, such as BonAmi<sup>®</sup>, Ajax<sup>®</sup>, or Comet<sup>®</sup>. They may permanently damage the finish or remove graphics.</li> </ul>
<b>Grommet</b> / Rubber	<ul style="list-style-type: none"> <li>• Hot sudsy water; rinse and dry immediately.</li> <li>• To remove grommet, gently push toward center and lift up.</li> </ul>	<ul style="list-style-type: none"> <li>• Do not soak grommets.</li> <li>• Do not pull on grommet when removing or replacing.</li> </ul>
<b>Exterior Finish</b> / Stainless Steel	<ul style="list-style-type: none"> <li>• Nonabrasive cleaners: Hot water and detergent, Fantastic<sup>®</sup>, Formula 409<sup>®</sup>. Rinse and dry immediately.</li> <li>• Cleaner polish: Stainless Steel Magic<sup>®</sup> to protect the finish from staining and pitting; enhances appearance.</li> <li>• Hard water spots: Household white vinegar.</li> <li>• Mild Abrasive Cleaners: Kleen King<sup>®</sup> stainless steel liquid cleaner, Cameo<sup>®</sup> aluminum &amp; stainless steel cleaner, Bon Ami<sup>®</sup>.</li> <li>• Heat discoloration: Bar Keepers Friend<sup>®</sup>.</li> </ul>	<ul style="list-style-type: none"> <li>• Stainless steel resists most food stains and pit marks providing the surface is kept clean and protected.</li> <li>• Never allow food stains or salt to remain on stainless steel for any length of time.</li> <li>• Rub lightly in the direction of polish lines.</li> <li>• Chlorine or chlorine compounds in some cleaners are corrosive to stainless steel. Check ingredients on label before using.</li> </ul>
<b>Grates</b> / Porcelain Enamel on Cast Iron	<ul style="list-style-type: none"> <li>• Nonabrasive cleaners: Hot water and detergent, Fantastic, Formula 409. Rinse and dry immediately.</li> <li>• Mild abrasive cleaners: Bon Ami<sup>®</sup> and Soft Scrub<sup>®</sup>.</li> <li>• Abrasive cleaners for stubborn stains: soap-filled steel wool pad.</li> </ul>	<ul style="list-style-type: none"> <li>• The grates are heavy; use care when lifting. Place on a protected surface.</li> <li>• Blisters / crazing / chips are common due to the extreme temperatures on grate fingers and rapid temperature changes.</li> <li>• Acidic and sugar-laden spills deteriorate the enamel. Remove soil immediately.</li> <li>• Abrasive cleaners, used too vigorously or too often, can eventually mar the enamel.</li> </ul>
<b>Igniters</b> / Ceramic	<ul style="list-style-type: none"> <li>• Carefully wipe with a cotton swab dampened with water, ammonia or Formula 409<sup>®</sup>.</li> <li>• Gently scrape soil off with a toothpick.</li> </ul>	<ul style="list-style-type: none"> <li>• Avoid excess water on the igniter. A damp igniter will prevent burner from lighting.</li> <li>• Remove any lint that may be remain after cleaning.</li> </ul>

# PROBLEM SOLVER

## BEFORE CALLING FOR SERVICE

### IF BURNERS DO NOT IGNITE PROPERLY, CHECK FOR THE FOLLOWING:

- Make sure that the gas shut-off valve is in the ON position and the gas supply to the house is not shut off.
- Make sure the burner caps are properly positioned and the burner ports are not clogged. Clear ports with a wire or straightened paper clip if clogged.
- Make sure the igniters are clean and dry.
- Make sure that there is no draft in the room.
- Check the power supply. It should be properly grounded with the correct polarity. Make sure the unit is plugged in and the circuit breaker is not tripped.
- When the electrical power connection has been activated at the first power up or re-connected after an outage, the igniters may spark once or twice even though all burner knobs are in the off position.

### For Authorized Service or Parts

We want you to be a satisfied customer. If a situation arises that has not been resolved to your satisfaction, please let us know. Call 800-944-2904 or write us at:

BSH Home Appliances Corp.  
Customer Support  
5551 McFadden Ave.,  
Huntington Beach, CA 92649

Please include the Model Number, Serial Number and Date of Original Purchase / Installation with all communication. (See Back Cover)

# WARRANTY

## BOSCH COOKTOP WARRANTY NGT73 / NGT93 / NPG73 / NPG93

### WHAT IS COVERED

#### Full One Year Warranty

For one year from the date of installation or date of occupancy for a new, previously unoccupied dwelling, any part which fails in normal home use will be repaired or replaced free of charge. Save your dated receipt or other evidence of the installation/occupancy date. Bosch will pay for all repair labor and replacement parts found to be defective due to materials and workmanship. Service must be provided by a Factory Authorized Service Agency during normal working hours. For a Service Agency nearest you, please phone 800/944-2904.

### WHAT IS NOT COVERED

1. Service by an unauthorized agency. Damage or repairs due to service by an unauthorized agency or the use of unauthorized parts.
2. Service visits to:
  - Teach you how to use the appliance.
  - Correct the installation. You are responsible for providing electrical wiring and/or gas installation and other connecting facilities.
  - Reset circuit breakers or replace home fuses.
3. Damage caused from accident, alteration, misuse, abuse, improper installation or installation not in accordance with local electrical codes or plumbing codes, or improper storage of the appliance.
4. Repairs due to other than normal home use.
5. Any service visits and labor costs during the limited warranty.
6. Travel fees and associated charges incurred when the product is installed in a location with limited or restricted access, (i.e., airplane flights, ferry charges, isolated geographic regions).

### WARRANTY APPLICATION

This warranty applies to appliances used in residential application. It does not cover their use in commercial situations.

This warranty is for products purchased and retained in the 50 states of the U.S.A., the District of Columbia and Canada. The warranty applies even if you should move during the warranty period. Should the appliance be sold by the original purchaser during the warranty period, the new owner continues to be protected until the expiration date of the original purchaser's warranty period.

**BOSCH DOES NOT ASSUME ANY RESPONSIBILITY FOR INCIDENTAL OR CONSEQUENTIAL DAMAGES.** Some states do not allow the exclusion or limitation of incidental or consequential damages, so the above limitation or exclusion may not apply to you. This warranty gives you specific legal rights and you may also have other rights which may vary from state to state or province to province.

### SERVICE DATA

For handy reference, the serial tag information has been affixed to the back cover. For location of the serial tag on the product, see Page 3. Keep your invoice for warranty validation. To obtain service, see Page 10.

## Model Information

The model/rating plate, located on the bottom surface of the cooktop, shows the model number and serial number of your cooktop. This is information you will need if your cooktop should ever need service. Below you will find the rating plate.

--

As a handy reference, copy the information from the model/rating plate in space provided below. Also keep your invoice. The invoice as well as the information listed below will be required for warranty validation.

Model No.		Dealer's Name	
Serial No.			
Date of Purchase		Dealer's Phone	

Specifications are for planning purposes only. Refer to installation instructions and consult your countertop supplier prior to making counter opening. Consult with a heating and ventilating engineer for your specific ventilation requirements. For the most detailed information, refer to installation instructions accompanying product or write to BSH Home Appliances Corp. indicating model number.

We reserve the right to change specifications or design without notice. Some models are certified for use in Canada. BSH is not responsible for products which are transported from the United States for use in Canada. Check with your local Canadian distributor or dealer.

For the most up to date critical installation dimensions by fax, use your fax handset and call 775/833-3600. Use code #8317.

# BOSCH

555 I McFadden Avenue, Huntington Beach, CA 92649 • 800/944-2904  
©2002 BSH Home Appliance Corp. • Litho U.S.A. 01/02  
5060003616 (8202)