

GE Monogram®

Installation

Instructions

Stainless Steel
Professional Outdoor
Cooking Centers

48" Natural gas models:

ZGG48N42

ZGG48N31

48" Liquid Propane models:

ZGG48L42

ZGG48L31

36" Natural gas models:

ZGG36N31

ZGG36N21

36" Liquid Propane models:

ZGG36L31

ZGG36L21

27" Natural gas models:

ZGG27N21

ZGG27N20

27" Liquid Propane models:

ZGG27L21

ZGG27L20

Before you begin—Read these instructions completely and carefully.

IMPORTANT: Save these instructions for local inspector's use.

IMPORTANT: OBSERVE ALL GOVERNING CODES AND ORDINANCES.

NOTE TO INSTALLER: Be sure to leave these instructions with the Consumer.

NOTE TO CONSUMER: Keep these instructions with your Use and Care Book for future reference.

If you received a damaged cooking center, you should contact your dealer.

Installation of this cooking center requires basic mechanical skills. Proper installation is the responsibility of the installer.

**For Monogram local service in your area,
1-800-444-1845.**

For Monogram service in Canada, 1-888-880-3030.

**For Monogram Parts and Accessories, call
1-800-626-2002.**

In the Commonwealth of Massachusetts:

- This product must be installed by a licensed plumber or gas fitter.
- When using ball type gas shut off valves, they shall be T-handle type.
- A flexible gas connector, when used, must not exceed 3 feet.

FOR YOUR SAFETY:

Do not use cooking center in a space where gasoline or other liquids having flammable vapors are stored or used.

CAUTION:

- **For outdoor use only.** Use this cooking center only in the manner intended by the manufacturer.
- This outdoor cooking gas appliance is not intended to be installed in or on recreational vehicles and/or boats.
- Do not use the grill in an explosive atmosphere. Keep the grill away from areas where gasoline or other flammable liquids and vapors are stored or being used.
- Observe proper clearances to combustible materials at all times.
- Do not use a rusty or damaged LP tank.
- Never substitute gases (natural for LP or LP for natural). These grills are factory set for LP or natural gas. Order the model for your installation situation.
- When storing the grill indoors, disconnect the LP tank. Store the tank outdoors in a well ventilated area.
- Do not store additional LP tanks in or near the gas grill.
- Follow the guidelines on the LP tank for proper storage, transport and handling.
- LP models are supplied with a 20 lb. LP tank (shipped separately) equipped with a Type I Acme connector. The supplied regulator has a mating connector.
- The supplied LP tank is equipped with an overflow protection device. If you utilize a tank exchange system, be sure to exchange this tank for a tank with the same device.

IF YOU SMELL GAS:

- Shut off gas to appliance.
- Extinguish any open flame.
- Open lid.
- If odor continues, immediately call your gas supplier.

- Tested in accordance with ANSI Z21.58 latest edition standard for outdoor cooking gas appliances. This grill is for outdoor use only. Check local building codes for the proper method of installation in the absence of local codes, this unit should be installed in accordance with the National Fuel Gas Code No. Z223 latest edition and the National Electrical Code ANSI/NFPA no. 70, latest edition.

CALIFORNIA PROPOSITION 65 - WARNING
The burning of gas cooking fuel generates some by products that are on the list of substances which are known by the State of California to cause cancer or reproductive harm. California law requires businesses to warn customers of potential exposure to such substances. To minimize exposure to these substances, always operate this unit according to the use and care manual, ensuring you provide good ventilation when cooking with gas.

INSECT WARNING!

Spiders and insects can nest in the burners of this and any other grill, and cause the gas to flow from the front of the burner. This is a very dangerous condition which can cause a fire to occur behind the valve panel, thereby damaging the grill and making it unsafe to operate. Inspect the grill twice a year or immediately if any symptoms appear.

Contents

Models Available	3	LP Gas Models	9
Accessories	3	Natural Gas Models	9
Product Dimensions & Clearances	4	Electrical Supply	10
Advance Planning	5	Step 4: Test for Leaks	10
Choosing the Location	5	Step 5: Check Burners, Replace Drip Trays and Grates	11
Tools & Materials Required	5	Step 6: Lighting the Grill	12
Step 1: Remove the Packaging	6	Step 7: Adjusting the Burners	13
Step 2: Provide Support	7	Install Rotisserie	14
Built-In Installations	7, 8	Install Access Doors	15
Step 3: Provide Gas & Electrical Supply	9		

Models Available

Monogram Outdoor Cooking Centers are factory set for LP or natural gas. Order the model for your installation situation.

48" Natural gas models:

ZGG48N42
4 grill burners, 2 rear infra red burners
ZGG48N31
3 grill burners, 1 rear infra red burner, and
2 side burners

36" Natural gas models:

ZGG36N31
3 grill burners, 1 rear infra red burner
ZGG36N21
2 grill burners, 1 rear infra red burner, and
2 side burners

27" Natural gas models:

ZGG27N21
2 grill burners, 1 rear infra red burner
ZGG27N20
2 grill burners

48" Liquid Propane models:

ZGG48L42
4 grill burners, 2 rear infra red burners
ZGG48L31
3 grill burners, 1 rear infra red burner, and
2 side burners

36" Liquid Propane models:

ZGG36L31
3 grill burners, 1 rear infra red burner
ZGG36L21
2 grill burners, 1 rear infra red burner, and
2 side burners

27" Liquid Propane models:

ZGG27L21
2 grill burners, 1 rear infra red burner
ZGG27L20
2 grill burners

Accessories

All models may be installed on a portable grill cart or built into an enclosure. Enclosures can be constructed of non-combustible (masonry) material or of combustible material such as wood. Insulated jackets are required for installation into combustible enclosures.

Grill Carts:

ZX48CTA, for 48" wide models.
ZX36CTA, for 36" wide models.
ZX27CTA, for 27" wide models.

Insulated Jackets for Combustible enclosure:

ZX48JYSS, for 48" wide models.
ZX36JYSS, for 36" wide models.
ZX27JYSS, for 27" wide models.

27" Model Trim Kit

ZX27TKYSS is available to conceal the gap between the cooking center and enclosure.

ZXADYSS - Stainless Steel Double Access Doors

Optional accessories to cover the access opening under the grill in a built-in installation.

Vinyl Covers:

Tough vinyl, felt lined with elastic bottom.
ZX48CVCC, fits all 48" models on cart.
ZX48CV4Y, fits 48" built-in's with 4 burners.
ZX48CV3Y, fits 48" built-in's with 3 burners.
ZX36CVCC, fits all 36" models on cart.
ZX36CV3Y, fits 36" built-in's with 3 burners.
ZX36CV2Y, fits 36" built-in's with 2 burners.
ZX27CVCY, fits 27" "Y" models on cart.
ZX27CVCC fits 27" "C" models on cart.
ZX27CV2Y, fits all 27" built-in models.
ZX27CVDY, fits all 27" models on cart when fitted with side dual range top burner.
ZX2LYSS - Dual range top burner - LP Gas
ZX2NYSS - Dual range top burner - Nat. Gas
Can be installed on the right side of a 27" cart. For built in installations order Trim Kit ZX2TKYSS to conceal the gap between the side and rear edges of the opening.
Insulated jacket ZX2JYSS is required for installation into a combustible enclosure.
ZX27QDC - LP Quick Disconnect Tee
For installation onto a 27" cart.

Design Information

Outdoor Cooking Centers

Product Dimensions & Clearances

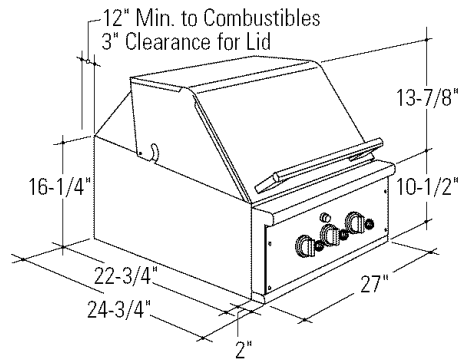

27" Wide Models

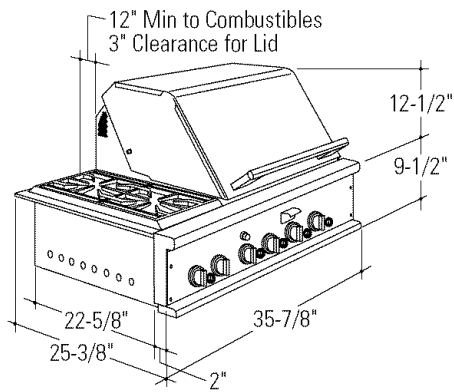

36" Wide Models

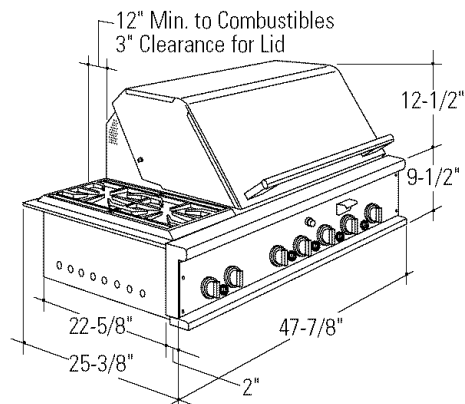

48" Wide Models

Design Information

Outdoor Cooking Centers

Advance Planning

- Monogram Outdoor Cooking Centers are designed to be installed on a grill cart or into an enclosure.

27" Models:

- In a non-combustible (masonry) enclosure, the grill drops into the opening. A deck or ledge on each side is required for support from the bottom.
- Insulated jackets are available to allow the grill to be installed in a combustible enclosure. The insulated jacket must be supported from the bottom by a solid deck or ledge on each side beneath the jacket.
- If using a backsplash or rear wall, locate the electrical service for the rotisserie on the left side.
- Trim kit ZX27TKYSS is available to conceal the gap between cooking center and the back and sides of an enclosure.

36" and 48" Models:

- In a non-combustible (masonry) enclosure, the grill drops into the opening and hangs from its side flanges. A deck is not required for support.
- Insulated jackets are available to allow these grills to be installed in a combustible enclosure. The insulated jacket must be supported from the bottom by a solid deck or ledge on each side beneath the jacket.
- If using a backsplash or rear wall, locate the electrical service for the rotisserie on the right side of the opening.

Clearances—All Models

- Allow 3" at the rear for lid clearance.
- Allow at least 12" clearance at the back of the grill when exhaust is directed to a window or a surface that is difficult to clean.
- Allow at least 6" clearance on each side to any non-combustible material located above the cooking surface for counterspace. Rotisserie models also require 6" clearance for placing and handling the motor and skewer.
- Allow at least 12" clearance on each side and rear to combustible vertical materials.

Choosing the Location

- **These cooking centers are designed for outdoor use only.** Do not locate the grill in a building, garage or other enclosed area.
- Ensure that fresh air ventilation is adequate.
- Consider exposure to wind and proximity to traffic paths.
- The minimum clearances to combustibles must be maintained at all times.

- Do not install a grill below overhead unprotected combustible construction.
- The installation must conform to local codes or in the absence of local codes, with the national fuel gas code, ANSI Z223 latest edition.
- The location must be level and stable.

Tools & Materials Required (Not supplied)

- Phillips head screwdriver
- Pipe wrench
- Level
- Flat blade screwdriver (3/32" blade)
- Pliers
- Appropriate gas line to reach built-in installation location
- Pipe joint sealant, approved type and resistant to LP gases
- Manual shut-off valve

CAUTION: All cooking centers are extremely heavy. 2 people are required for lifting and placing the product into a cart or enclosure.

Installation

Outdoor Cooking Centers

Step 1 Remove the Packaging

- Open the box and remove packaging.
- Open the grill lid and remove white plastic tie-downs on burners.
- Remove side burner grate and aeration pan.
- Remove tie-downs on burners.
- Open the hardware accessory carton and check contents.

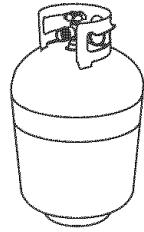

Type 1 Acme, 20 lb. LP tank
(LP models only)

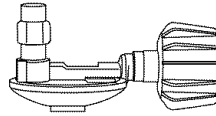

LP Regulator

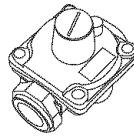

Natural Gas Regulator

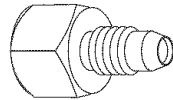

1/2" NPT to 3/8 flare adaptor

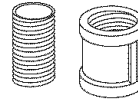

Coupler and Nipple
(Natural Gas Models)

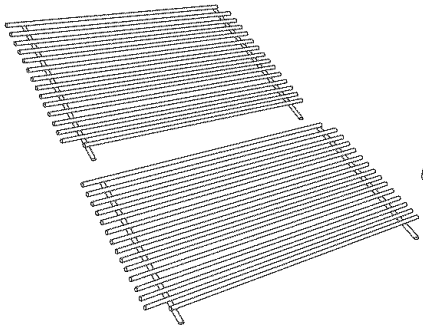

Grill Grates

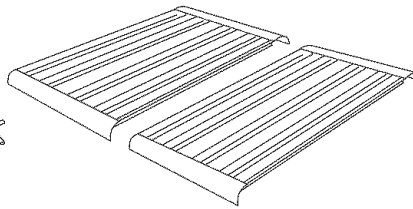

Gourmet Radiant™ Trays

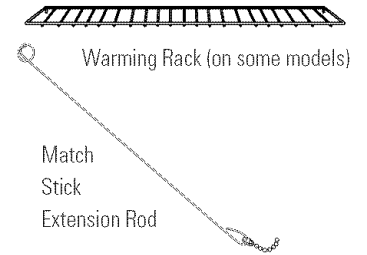

Warming Rack (on some models)

Match
Stick
Extension Rod

36" and 48" models have side shipping brackets. Remove side brackets when installing into an enclosure. Shipping brackets may remain in place when installing into a cart.

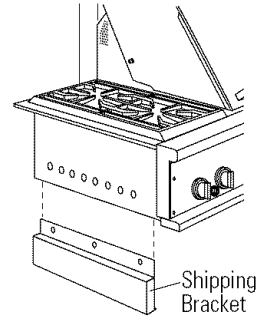

Shipping Bracket

27" models are mounted to a shipping panel. Remove bolts and discard panel.

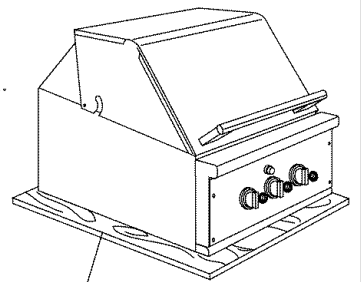

Shipping Support

Rotisserie rod, handle, holders and motor (on models so equipped).

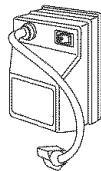

27" Motor

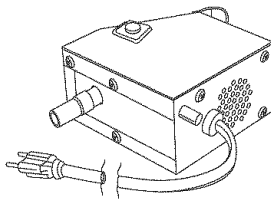

36"/48" Motor

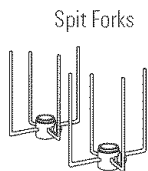

Spit Forks



Rotisserie Rod and Handle

Models with side burners.

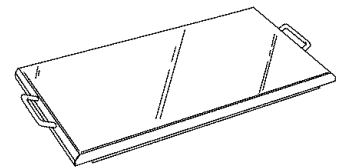

Side Burner Cover

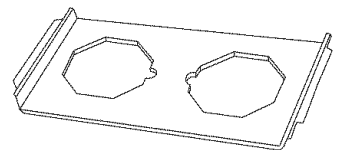

Side Burner Aeration Pan

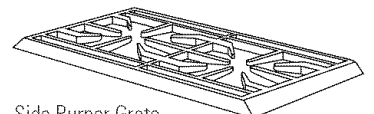

Side Burner Grate

Installation

Outdoor Cooking Centers

Step 2 Provide Support

All Outdoor Cooking Centers can be installed on a cart designed specifically for that model size. Follow the installation instructions provided with the carts to install. Proceed to Gas supply to complete the installation.

CAUTION: The grill is heavy. 2 people are required to lift and place the grill into the cart or the enclosure.

Built-In Installation

- All models may be installed into a combustible or non-combustible enclosure.
- Combustible enclosures require the use of an insulated jacket. Insulated jackets are available as a optional accessory. Order the specific type for your model.

Clearances

- Allow 3" at the rear for lid clearance.
- Allow at least 12" clearance at the back of the

grill when exhaust is directed to a window or a surface that is difficult to clean.

- Allow at least 6" clearance on each side to any non-combustible material located above the cooking surface for counterspace. Rotisserie models also require 6" clearance for placing and handling the motor and skewer.
- Allow at least 12" clearance on each side and rear to combustible vertical materials.

27" Models

ZX27TKYSS Trim Kit

This kit is designed for both combustible and non-combustible enclosures. The trim will conceal the gap at the rear and both sides of the opening.

- Secure trim to the sides and back with screws provided.
- Place the grill into the enclosure.

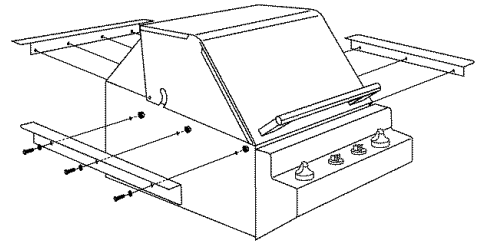

NOTE: This trim kit is not designed to support the weight of the grill. The grill must be supported from the bottom.

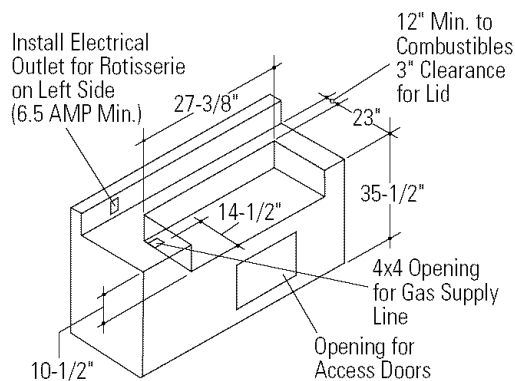

27" wide models:

Installation in a non-combustible enclosure.

- In a non-combustible (masonry) enclosure, the grill drops into the opening. A deck or ledge on each side is required for support from the bottom.

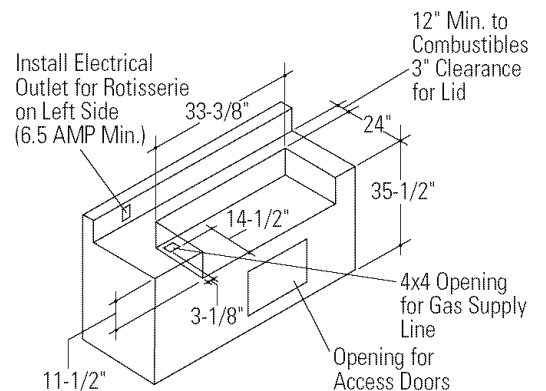

27" wide models:

Installation in a combustible enclosure.

ZX27JYSS insulated jacket is required

- The insulated jacket must be supported from the bottom by a solid deck or ledge on each side beneath the jacket.
- Construct the enclosure as shown and place the insulated jacket into the enclosure. Place the cooking center into the jacket. No installation hardware is required.

Installation

Outdoor Cooking Centers

36" Models

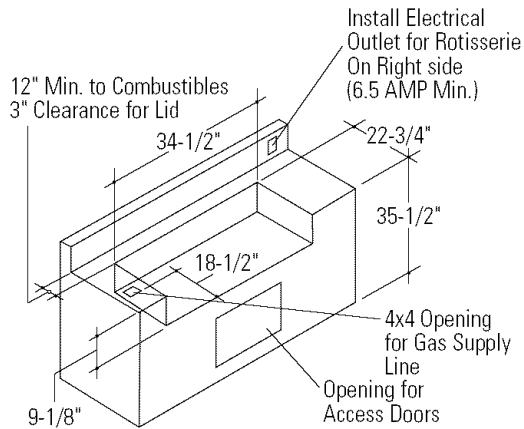

36" wide models:
Installation in a non-combustible enclosure.

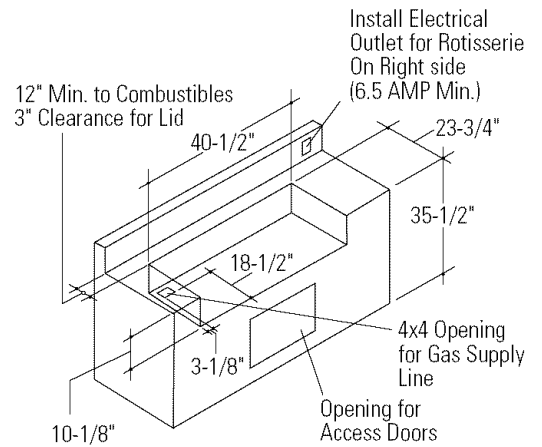

36" wide models:
Installation in a combustible enclosure.
ZX36JYSS insulated jacket is required.

48" Models

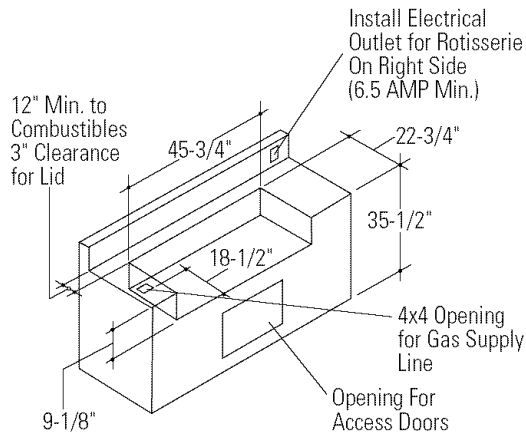

48" wide models:
Installation in a non-combustible enclosure.

- In a non-combustible (masonry) enclosure, the grill drops into the opening and hangs from its side flanges. A deck is not required for support.

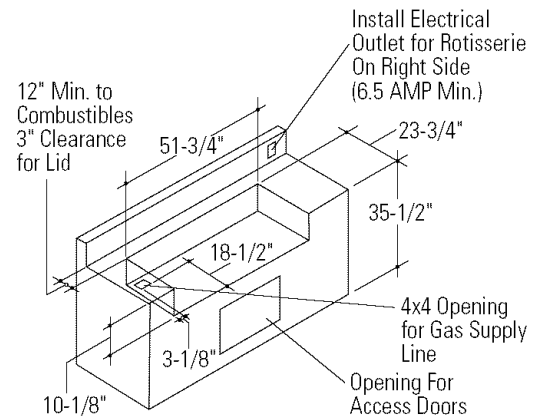

48" wide models:
Installation in a combustible enclosure.
ZX48JYSS insulated jacket is required.

- Combustible enclosures require insulated jackets. ZX36JYSS for 36" models and ZX48JYSS for 48" wide models. The insulated jacket must be supported from the bottom by a solid deck or ledge on each side beneath the jacket.
- Construct the enclosure as shown and place the insulated jacket into the enclosure. Place the cooking center into the jacket. No installation hardware is required.

Installation

Outdoor Cooking Centers

Step 3 Provide Gas & Electrical Supply

WARNING **PRODUCT STORAGE**
When storing LP models indoors, disconnect the LP tank. Store the tank outdoors in a well ventilated area.
Do not store spare LP tanks in or near the Outdoor Cooking Center enclosure.

LP GAS MODELS

- Connect the regulator/Quick Connect assembly to the hose attached to the grill.
- The Quick Connect type coupling requires the user to pull on the outer sleeve of the female coupling while simultaneously inserting the male hose end into the coupling, then release the locking outer sleeve.

To connect the tank:

- Insert the coupler sleeve on the regulator over the tank inlet, turn clockwise to tighten.

To disconnect the tank:

- Turn off the main tank valve.
- Grasp the coupler sleeve and turn counter-clockwise. Remove the inlet from the opening.

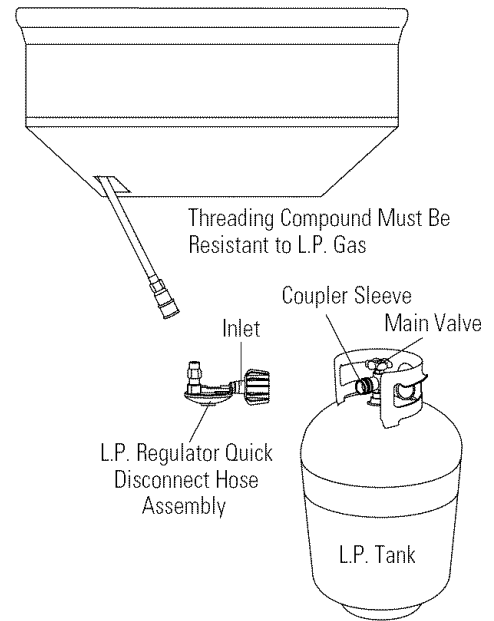

LP operating pressure is 10" W.C.

CAUTION: The LP tank (shipped separately) is a Type 1 Acme. Do not attempt to change or alter these supplied parts. Do not attempt to use the regulator/hose assembly with a standard 510 POL tank/valve assembly.

NATURAL GAS MODELS

The grill and its individual shut-off valve must be disconnected from the gas supply during any pressure testing of the system at test pressures in excess of 1/2 PSIG.

The grill must be isolated from the gas supply system by closing its individual shut-off valve during any pressure testing of the system at test pressures equal to or less than 1/2 PSIG.

The installation of these grills must conform with local codes or, in the absence of local codes, with the National fuel gas code, ANSI Z223 latest edition.

Operating pressure is 4" W.C.
Supply pressure should be 5" to 14" W.C. If pressure is more than 14" W.C. a step down regulator is required.

Check with local gas utility or with local codes for instructions on installing gas supply lines. Be sure to check on type and size of run and how deep to bury the line. If the gas line is too small, the grill will not function properly.

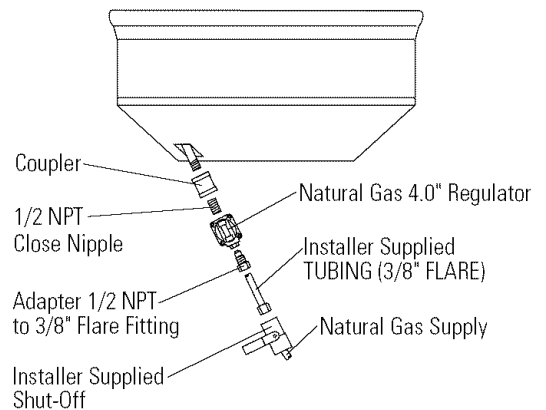

- Install a manual gas shut-off valve in an easily accessible location.
- Use threading compound on male threads only. Do not use threading compound on the male end of the 1/2 NPT to 3/8 flare adapter.
- Make connections as shown.
- Check to be sure the regulator arrow points in the direction of gas flow, towards the grill and away from the gas supply.

ELECTRICAL SUPPLY

Models with rotisserie require 120V, 60Hz. and connected to an individual properly grounded branch circuit protected by a 15 amp circuit breaker or time delay fuse.

The power cord on the rotisserie is equipped with a three-prong (grounding) plug which mates with a standard three-prong grounding wall receptacle to minimize the possibility of shock hazard from this appliance.

If the electrical service provided does not meet the above specifications, it is recommended that a licensed electrician install an approved outlet.

DO NOT UNDER ANY CIRCUMSTANCES, CUT OR REMOVE THE THIRD (GROUND) PRONG FROM THE POWER CORD.

- For 27" wide built-in grills, locate the electrical outlet on the left hand side within reach of the rotisserie's 72" power cord.
- For 36" and 48" wide built-in grills, locate the electrical outlet on the right hand side within reach of the rotisserie's 30" power cord.

Step **4** *Test for Leaks*

 WARNING TEST FOR LEAKS
A complete gas tightness check must be performed at the installation site. Do not use a flame to check for gas leaks.

- Do not use the grill until all connections have been leak tested.
- Repeat leak test after each LP tank change.
- Check to be sure the main valve on the LP tank or the shut-off valve is in the "OFF" position.
- Make a soap solution of one part liquid detergent and one part water.

The valve panel must be removed to check the valves and fittings.

- All control valves should be in the "OFF" position.
- Remove the knobs.
- On models equipped with Rotisserie, remove the safety valve pushbutton and unscrew the surrounding bezel.
- Remove the 4 screws holding the valve panel to the grill.
- Pull the panel outwards and unplug the wires from the back of the rotary igniters.
- If the grill has an optional rotisserie burner, remove the screws holding the inspection cover in place.

TO TEST:

- Apply the soap solution around the connections, valve and tubing.
- Turn the gas supply on.
- Check all connections from the supply line or LP tank up to and including the manifold pipe assembly.
- If a leak is detected, turn gas supply to off and tighten fittings. Turn the gas on and check again.
- To re-install the valve panel, re-connect the igniter wires and secure the panel with original screws.

Step 5

Check Burners, Drip Trays and Grates

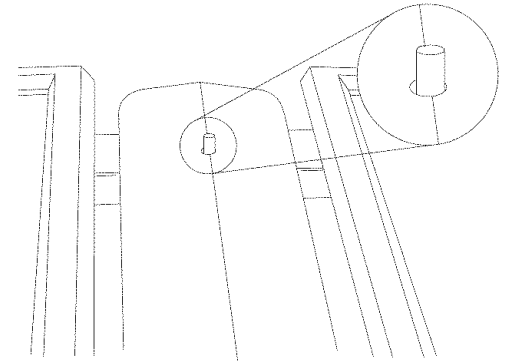
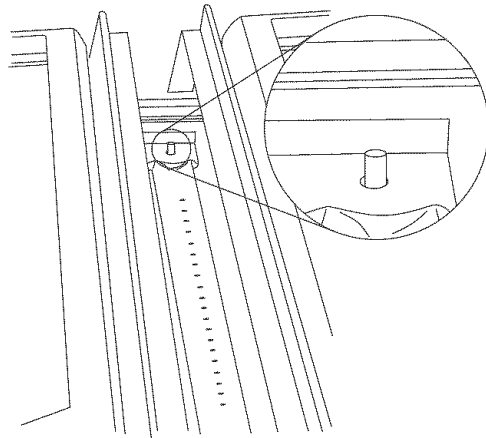

- During shipping parts, such as burners and reflectors may have moved. Check to be sure all parts are in position.

- Remove the smoker tray (if so equipped). Check to be sure smoker burner and deflector plate are installed properly. The burner and plate should be placed over the holding pin at the back and front of the grill.

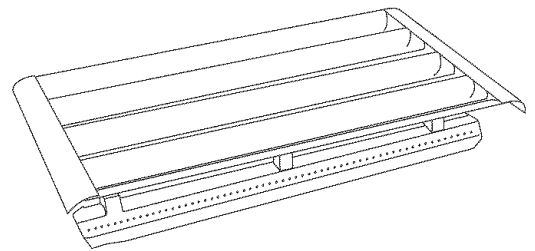
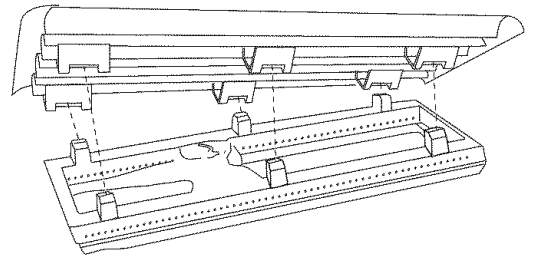
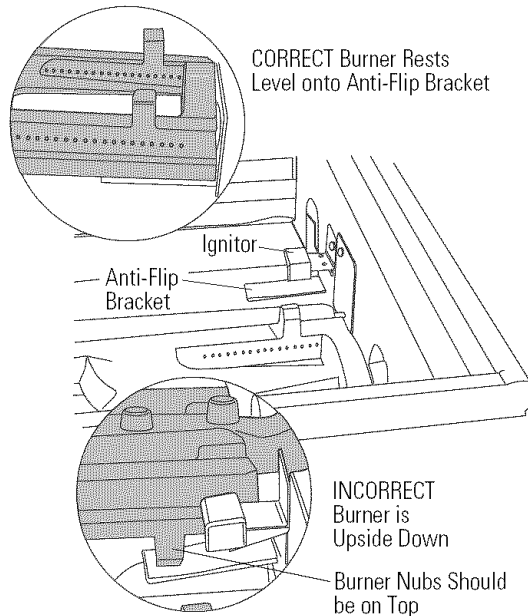

Check to be sure all burners are in the correct position. Burners should rest flat over the anti-flip brackets with stubs on top and flat side down.

- Check to be sure that all grill burners are level and securely seated in the grill box.
- Place Gourmet radiant on top of each burner. Clips on the bottom of the radiant fits over stubs on the burners. It should be centered in the grill box front to rear.
- Place the grill grates over the opening.
- Slide drip tray into place.

Step
6
*Lighting
the Grill*

WARNING Do not attempt to light the grill if the odor of gas is present.

CAUTION: Keep hands and face as far away from the grill as possible when lighting.

- Open the lid and remove the side cooktop burner cover.
- Turn all knobs to “OFF” position.
- Turn gas supply on at the LP tank or shut-off valve.

NOTE: When lighting the burner for the first time or after a LP tank change, allow up to 20 seconds to purge air from the lines.

- Push and turn control knob to “LITE” position, immediately turn the rotary igniter knob next to the burner knob.

NOTE: The spark will produce a snapping sound. This is normal.

- If the burner does not light within 4 seconds, turn knobs to “OFF” and wait 5 minutes for the gas to dissipate before trying again.
- If the burner does not light after several attempts, the burner can be lit with a match.

- A match stick extension rod is provided on some models.

TO MATCH LIGHT:

- Insert a match stick (DO NOT LIGHT) securely into the clip end of the match stick extension rod.
- Light the match stick held on the end of the rod and hold against a burner port towards the front.

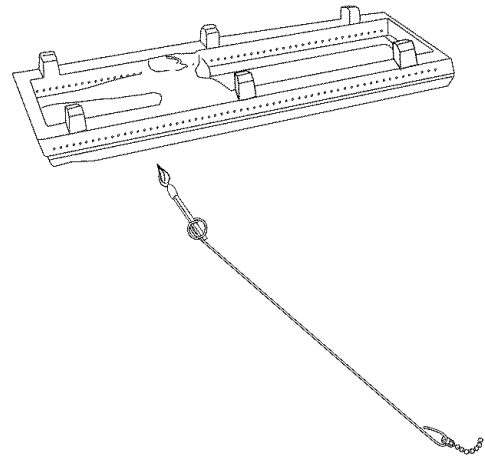

- Push and turn the corresponding control knob to the LITE position.
- If the burner does not light after 4 seconds, turn the knob OFF. Wait 5 minutes for any accumulated gas to dissipate before trying to light the burner again.
- All burners may be match lit in the same manner.
- If the match light extension rod is not provided with your model, refer to the Owners Manual for lighting instructions.

Installation

Outdoor Cooking Centers

Step 7

Adjusting the Burners

Adjustments should not be required, unless vibration during transit or variations in local gas supply make minor adjustments necessary.

Adjustments must be made by a qualified technician at the time of installation. Extreme care should be used if adjustments are made after installation.

- Turn gas supply on.
- Push and turn the burner control knobs to the "LITE" position. Up to 20 seconds may be required to purge air from the lines.
- Flames should be blue and stable with no yellow tips, excessive noise or lifting from the burner. If any of these conditions exist turn control to off and check air shutter and burner ports for debris or spider webs.

TO ADJUST:

- Remove burners by lifting and twisting while pulling towards the back.
- Locate and loosen the lock screw on the face of the air shutter with a screwdriver.
- Replace the burners.
- Turn burner knob to the "LITE" position.
- If the flame is yellow, indicating insufficient air, turn the air shutter open to allow more air to the burner.
- If the flame is noisy and tends to lift away from the burner, there is too much air. Turn the air shutter to reduce the opening.
- Side burners can be adjusted in the same manner.

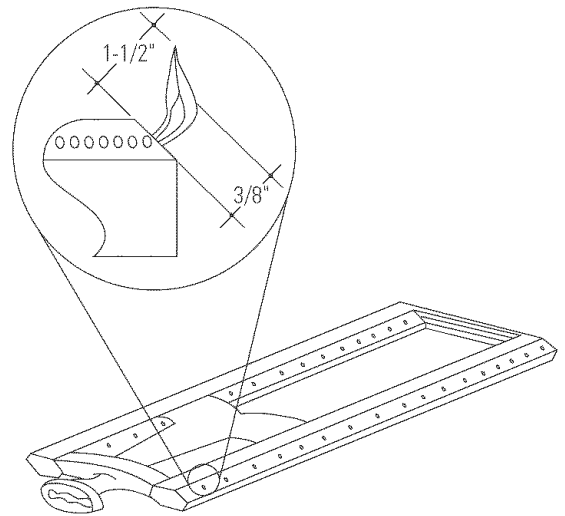

Low setting Adjustment:

Minor adjustments may be required due to fluctuations in local gas pressure. Adjustments to increase or decrease gas flow may be necessary.

- Turn burner knob to "LITE" position.
- Turn the control knob to the lowest setting, all the way counter-clockwise.
- Remove the knob by pulling straight out.
- Insert a thin-blade flat screwdriver into the valve shaft and hold. ($3/32$ " blade width recommended.)
- Grip the shaft with pliers and turn the screwdriver counter-clockwise to lower the flame, or clockwise to increase the flame.
- When the desired setting is made, replace the knob and turn burner off.

NOTE: Adjustment of the infra-red rotisserie burner is not recommended.

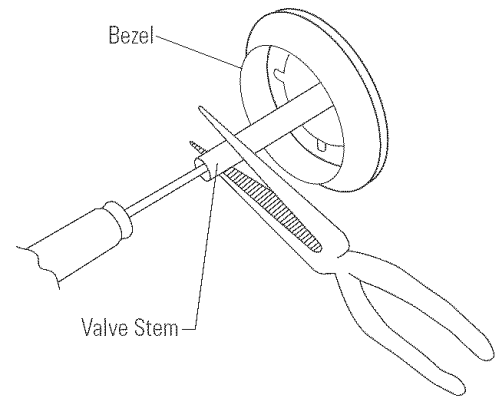

WARNING:

Always check the low flame size for stability. A burner flame which is too small may go out or be extinguished easily. This can cause unburned gas to escape and cause a hazardous condition.

Installation

Outdoor Cooking Centers

*Install
Rotisserie
(If so equipped)*

27" Wide Models:

- Slide the motor down into the channel on the left side and tighten thumb screw.
- To use, place pointed end of the skewer into the motor, and the threaded end resting on the right side support.
- Remove the handle from the threaded end of the skewer before using.

36" and 48" Wide Models:

- The motor will rest on the cast iron block and can be tightened against the grill by turning the black knob.
- To use, place pointed end of the skewer into the motor, and the threaded end resting on the right side support.
- Remove the handle from the threaded end of the skewer before using.

Install Access Doors

Outdoor Cooking Centers

ZXADYSS Double Access Doors

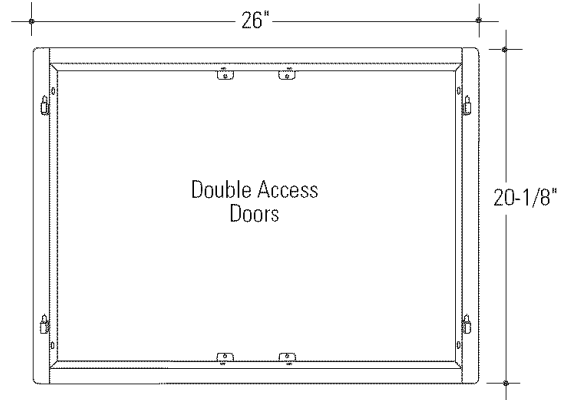
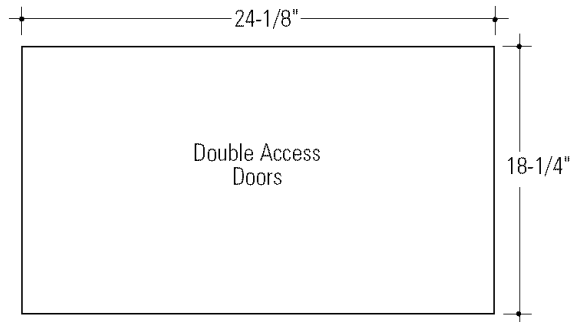

- The opening for double access doors should be 24-1/8" wide and 18-1/4" high.

Installation

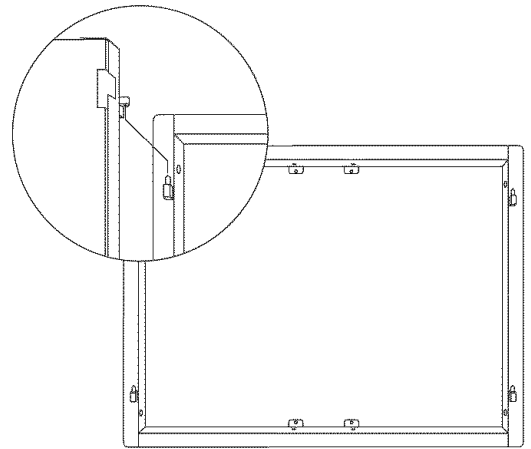
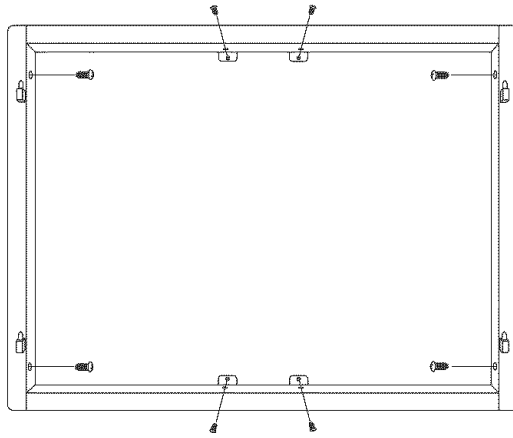

- Place the frame into the opening and secure with appropriate screws on all sides as shown.
- Hang the doors on the hinges as shown.

Note: While performing installations described in this book, safety glasses or goggles should be worn.

For Monogram® local service in your area, call 1-800-444-1845.

Note: Product improvement is a continuing endeavor at General Electric. Therefore, materials, appearance and specifications are subject to change without notice.



Monogram®
We bring good things to life.

GE Consumer Products
General Electric Company
Louisville, KY 40225
© 2003 General Electric Company

Pub. No. 49-80009-3
Dwg. No. 164D3333P227

(N.D. 728) 3/03

10743-Rev. 3