

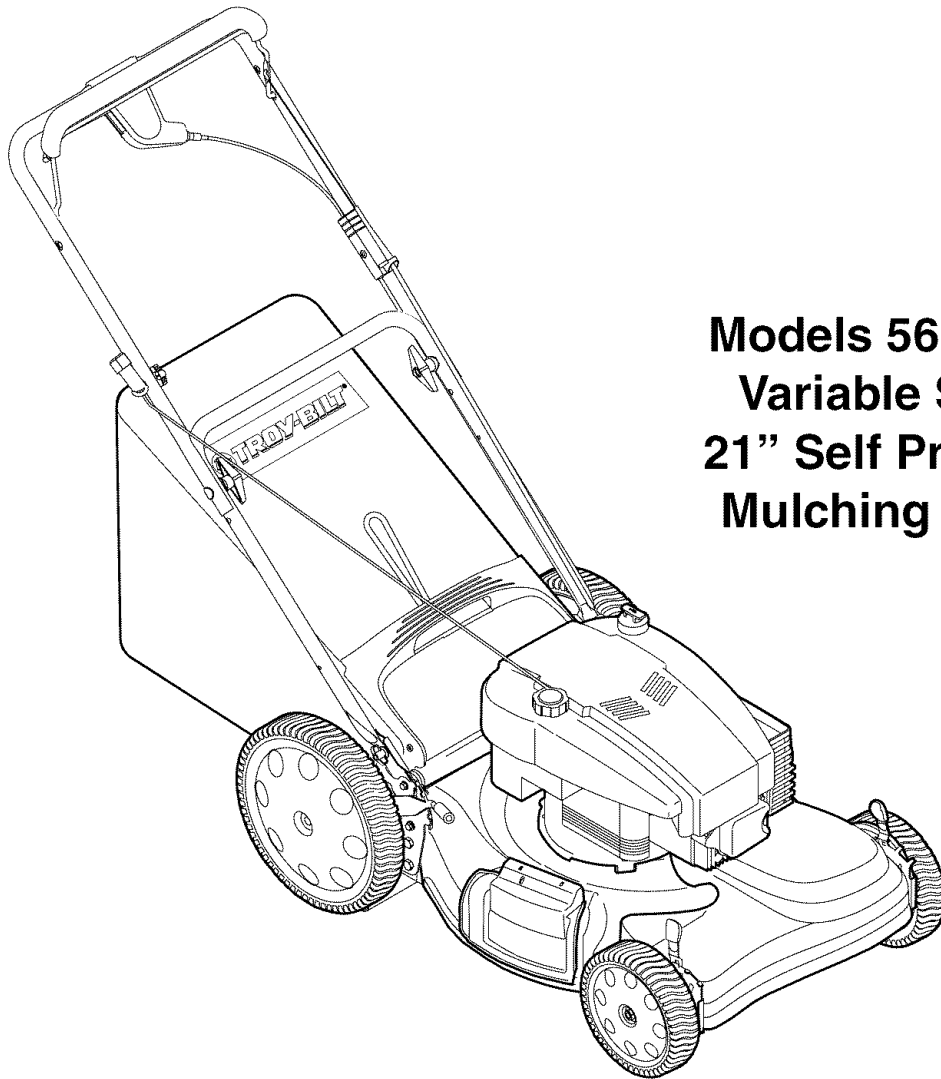

# Operator's Manual



**Models 566 & 569  
Variable Speed  
21" Self Propelled  
Mulching Mower**

**IMPORTANT:** Read safety rules and instructions carefully before operating equipment.

**Warning:** This unit is equipped with an internal combustion engine and should not be used on or near any unimproved forest-covered, brush-covered or grass-covered land unless the engine's exhaust system is equipped with a spark arrester meeting applicable local or state laws (if any). If a spark arrester is used, it should be maintained in effective working order by the operator. In the State of California the above is required by law (Section 4442 of the California Public Resources Code). Other states may have similar laws. Federal laws apply on federal lands. A spark arrester for the muffler is available through your nearest engine authorized service dealer or contact the service department, P.O. Box 361131 Cleveland, Ohio 44136-0019.

**Troy-Bilt LLC, P.O. BOX 361131 CLEVELAND, OHIO 44136-0019**

PRINTED IN U.S.A.

FORM NO. 769-01542  
(12/2004)

## TABLE OF CONTENTS

Content	Page	Content	Page
Important Safe Operation Practices	3	Service and Adjustments	14
Slope Gauge	6	Off Season Storage	15
Assembling Your Lawn Mower	7	Trouble Shooting	16
Know Your Lawn Mower	10	Illustrated Parts List	18
Operating Your Lawn Mower	11	Warranty	20
Maintaining Your Lawn Mower	12		

## FINDING MODEL NUMBER

This Operator's Manual is an important part of your new lawn mower. It will help you assemble, prepare and maintain the unit for best performance. Please read and understand what it says.



**Before you start assembling your new equipment**, please locate the model plate on the equipment and copy the information from it in the space provided below. A sample model plate is also given below. You can locate the model plate by standing at the operating position and looking down at the rear of the deck. This information will be necessary to use the manufacturer's web site and/or help from the Customer Support Department or an authorized service dealer.



Copy the model number here: \_\_\_\_\_

Copy the serial number here: \_\_\_\_\_

## CUSTOMER SUPPORT

**Please do NOT return the unit to the retailer from where it was purchased, without first contacting Customer Support.**

If you have difficulty assembling this product or have any questions regarding the controls, operation or maintenance of this unit, you can seek help from the experts. Choose from the options below:

	<p>Visit <a href="http://www.troybilt.com">www.troybilt.com</a> for many useful suggestions. Click on Customer Support button and you will get the four options reproduced here. Click on the appropriate button and help is immediately available.</p> <div style="text-align: center; border: 1px solid black; padding: 5px; margin: 10px auto; width: 80%;"> <p><b>Find Answers</b> Click here to search our knowledge base. Search by product, keyword, or phrase.</p> <hr/> <p><b>My Stuff</b> Login to check the status of your questions, modify your inquiries, or update your personal profile.</p> <hr/> <p><b>Service Locator</b> Need local assistance? Click here to find authorized service centers in your area.</p> <hr/> <p><b>Manuals Online</b> Need a manual and/or parts list? Download literature from recent model years.</p> </div> <p style="text-align: center;"><i>The answer you are looking for could be just a mouse click away!</i></p>
	<p>If you prefer to reach a Customer Support Representative, please call <b>1-800-520-5520</b>.</p>
	<p>The <b>engine</b> manufacturer is responsible for all engine-related issues with regards to performance, power-rating, specifications, warranty and service. Please refer to the engine manufacturer's Owner's/Operator's Manual, packed separately with your unit, for more information.</p>

---

## SECTION 1: IMPORTANT SAFE OPERATION PRACTICES



**WARNING:** This symbol points out important safety instructions which, if not followed, could endanger the personal safety and/or property of yourself and others. Read and follow all instructions in this manual before attempting to operate this machine. Failure to comply with these instructions may result in personal injury. When you see this symbol—HEED ITS WARNING.

**WARNING:** Engine exhaust, some of its constituents, and certain vehicle components contain or emit chemicals known to State of California to cause cancer and birth defects or other reproductive harm.

**WARNING:** This machine was built to be operated according to the rules for safe operation in this manual. As with any type of power equipment, carelessness or error on the part of the operator can result in serious injury. This machine is capable of amputating hands and feet and throwing objects. Failure to observe the following safety instructions could result in serious injury or death.

### General Operation

1. Read this operator's manual carefully in its entirety before attempting to assemble this machine. Read, understand, and follow all instructions on the machine and in the manual(s) before operation. Be completely familiar with the controls and the proper use of this machine before operating it. Keep this manual in a safe place for future and regular reference and for ordering replacement parts.
2. This machine is a precision piece of power equipment, not a plaything. Therefore, exercise extreme caution at all times. Your unit has been designed to perform one job: to mow grass. Do not use it for any other purpose.
3. Never allow children under 14 years old to operate this machine. Children 14 years old and over should read and understand the operation instructions and safety rules in this manual and should be trained and supervised by a parent. Only responsible individuals who are familiar with these safe operation rules should use this machine.
4. Thoroughly inspect the area where equipment is to be used. Remove all stones, sticks, wire, bones, toys and other foreign objects which could be tripped over or picked up and thrown by the blade. Thrown objects can cause serious personal injury. Plan your mowing pattern to avoid discharge of material toward roads, sidewalks, bystanders and the like. Also, avoid discharging material against a wall or obstruction which may cause discharged material to ricochet back toward the operator.
5. To help avoid blade contact or a thrown object injury, stay in the operator zone behind the handles and keep bystanders, helpers, children and pets at least 75 feet from the machine while it is in operation. Stop machine if anyone enters the area.
6. Always wear safety glasses to protect your eyes during equipment operation and while performing an adjustment or repair. Thrown objects which ricochet can cause serious injury to the eyes.
7. Wear sturdy, rough-soled work shoes and close-fitting slacks and shirts. Shirts and pants that cover the arms and legs and steel-toed shoes are recommended. Never operate this machine in bare feet, sandals, slippery or light weight (e.g. canvas) shoes.
8. Do not put hands or feet near rotating parts or under the cutting deck. Contact with the blade can amputate hands and feet.
9. A missing or damaged discharge cover can cause blade contact or thrown object injuries.
10. Many injuries occur as a result of the mower being pulled over the foot during a fall caused by slipping or tripping. Do not hold on to the mower if you are falling; release the handle immediately.
11. Never pull the mower back toward you while you are walking. If you must back the mower away from a wall or obstruction first look down and behind to avoid tripping and then follow these steps:
  - a. Step back from the mower to fully extend your arms.
  - b. Be sure you are well balanced with sure footing.
  - c. Pull the mower back slowly, no more than half way toward you.
  - d. Repeat these steps as needed.
5. Do not operate the mower while under the influence of alcohol or drugs.
6. Do not engage the self-propelled mechanism on units so equipped while starting engine.
7. The blade control handle is a safety device. Never attempt to bypass its operation. Doing so makes the safety device inoperative and may result in personal injury through contact with the rotating blade. The blade control handle must operate easily in both directions and automatically return to the disengaged position when released.
8. Never operate the mower in wet grass. Always be sure of your footing. A slip and fall can cause serious personal injury. If you feel you are losing

your footing, release the blade control handle immediately and the blade will stop rotating within three seconds.

9. Mow in daylight or good artificial light; walk, not run.
10. Stop the blade when crossing gravel drives, walkways or roads.
11. If the equipment should start to vibrate abnormally, stop the engine and check immediately for the cause. Vibration is generally a warning of trouble.
12. Shut the engine off and wait until the blade comes to a complete stop before removing the grass catcher or unclogging the chute. The cutting blade continues to rotate for a few seconds after the engine is shut off. Never place any part of the body in the blade area until you are sure the blade has stopped rotating.
13. Never operate mower without proper trail shield, discharge cover, grass catcher, blade control handle or other safety protective devices in place and working. Never operate mower with damaged safety devices. Failure to do so can result in personal injury.
14. Muffler and engine become hot and can cause a burn. Do not touch.
15. Only use parts and accessories made by the original equipment manufacturer (O.E.M). Failure to do so can result in personal injury.
16. If situations occur which are not covered in this manual, use care and good judgment. Contact your dealer for assistance. Call 1-800-520-5520 for the name of your nearest dealer.

## Slope Operation

Slopes are a major factor related to slip and fall accidents which can result in severe injury. Operation on slopes requires extra caution. If you feel uneasy on a slope, do not mow it. Before operating this unit on a slope or hilly area, use the slope gauge on page 6 to measure slopes. If the slope is greater than 15 degrees, do not mow it.

### Do:

1. Mow across the face of slopes; never up and down. Exercise caution when changing direction.
2. Watch for holes, ruts, rocks, hidden objects, or bumps which can cause you to slip or trip. Tall grass can hide obstacles.
3. Always be sure of your footing. A slip and fall can cause serious personal injury. If you feel you are losing your balance, release the blade control handle immediately, and the blade will stop rotating within 3 seconds.

### Do Not:

1. Do not mow near drop-offs, ditches or embankments, you could lose your footing or balance.

2. Do not mow slopes greater than 15 degrees as shown on the slope gauge.
3. Do not mow on wet grass. Unstable footing could cause slipping.

## Children

Tragic accidents can occur if the operator is not alert to the presence of children. Children are often attracted to the mower and the mowing activity. They do not understand the dangers. Never assume that children will remain where you last saw them.

1. Keep children out of the mowing area and under the watchful care of a responsible adult other than the operator.
2. Be alert and turn mower off if a child enters the area.
3. Before and while moving backwards, look behind and down for small children.
4. Use extreme care when approaching blind corners, doorways, shrubs, trees, or other objects that may obscure your vision of a child who may run into the mower.
5. Keep children away from hot or running engines. They can suffer burns from a hot muffler.
6. Never allow children under 14 years old to operate a power mower. Children 14 years old and over should read and understand the operation instructions and safety rules in this manual and should be trained and supervised by a parent.

## Service

### Safe Handling of Gasoline:

1. To avoid personal injury or property damage use extreme care in handling gasoline. Gasoline is extremely flammable and the vapors are explosive. Serious personal injury can occur when gasoline is spilled on yourself or your clothes which can ignite.
2. Wash your skin and change clothes immediately.
3. Use only an approved gasoline container.
4. Never fill containers inside a vehicle or on a truck or trailer bed with a plastic liner. Always place containers on the ground away from your vehicle before filling.
5. If possible, remove gas-powered equipment from the truck or trailer and refuel it on the ground. If this is not possible, then refuel such equipment on a trailer with a portable container, rather than from a gasoline dispenser nozzle.
6. Keep the nozzle in contact with the rim of the fuel tank or container opening at all times until fueling is complete. Do not use a nozzle lock-open device.
7. Extinguish all cigarettes, cigars, pipes and other sources of ignition.
8. Never fuel machine indoors because flammable vapors will accumulate in the area.

9. Never remove gas cap or add fuel while the engine is hot or running. Allow engine to cool at least two minutes before refueling.
10. Never over fill fuel tank. Fill tank to no more than ½ inch below bottom of filler neck to provide space for fuel expansion.
11. Replace gasoline cap and tighten securely.
12. If gasoline is spilled, wipe it off the engine and equipment. Move unit to another area. Wait 5 minutes before starting the engine.
13. Never store the machine or fuel container inside where there is an open flame, spark or pilot light as on a water heater, space heater, furnace, clothes dryer or other gas appliances.
14. To reduce fire hazard, keep mower free of grass, leaves, or other debris build-up. Clean up oil or fuel spillage and remove any fuel soaked debris.
15. Allow a mower to cool at least 5 minutes before storing.

**General Service:**

1. Never run an engine indoors or in a poorly ventilated area. Engine exhaust contains carbon monoxide, an odorless and deadly gas.
2. Before cleaning, repairing, or inspecting, make certain the blade and all moving parts have stopped. Disconnect the spark plug wire and ground against the engine to prevent unintended starting.
3. Check the blade and engine mounting bolts at frequent intervals for proper tightness. Also, visually inspect blade for damage (e.g., bent, cracked, worn) Replace blade with the original equipment manufacturer's (O.E.M.) blade only, listed in this manual. "Use of parts which do not meet the original equipment specifications may

lead to improper performance and compromise safety!"

4. Mower blades are sharp and can cut. Wrap the blade or wear gloves, and use extra caution when servicing them.
5. Keep all nuts, bolts, and screws tight to be sure the equipment is in safe working condition.
6. Never tamper with safety devices. Check their proper operation regularly.
7. After striking a foreign object, stop the engine, disconnect the spark plug wire and ground against the engine. Thoroughly inspect the mower for any damage. Repair the damage before starting and operating the mower.
8. Never attempt to make a wheel or cutting height adjustment while the engine is running.
9. Grass catcher components, discharge cover, and trail shield are subject to wear and damage which could expose moving parts or allow objects to be thrown. For safety protection, frequently check components and replace immediately with original equipment manufacturer's (O.E.M.) parts only, listed in this manual. "Use of parts which do not meet the original equipment specifications may lead to improper performance and compromise safety!"
10. Do not change the engine governor setting or overspeed the engine. The governor controls the maximum safe operating speed of the engine.
11. Maintain or replace safety and instruction labels, as necessary.
12. Observe proper disposal laws and regulations. Improper disposal of fluids and materials can harm the environment.

**Your Responsibility**

- Restrict the use of this power machine to persons who read, understand and follow the warnings and instructions in this manual and on the machine.



## SECTION 2: SLOPE GAUGE

Use this page as a guide to determine slopes where you may not operate safely.

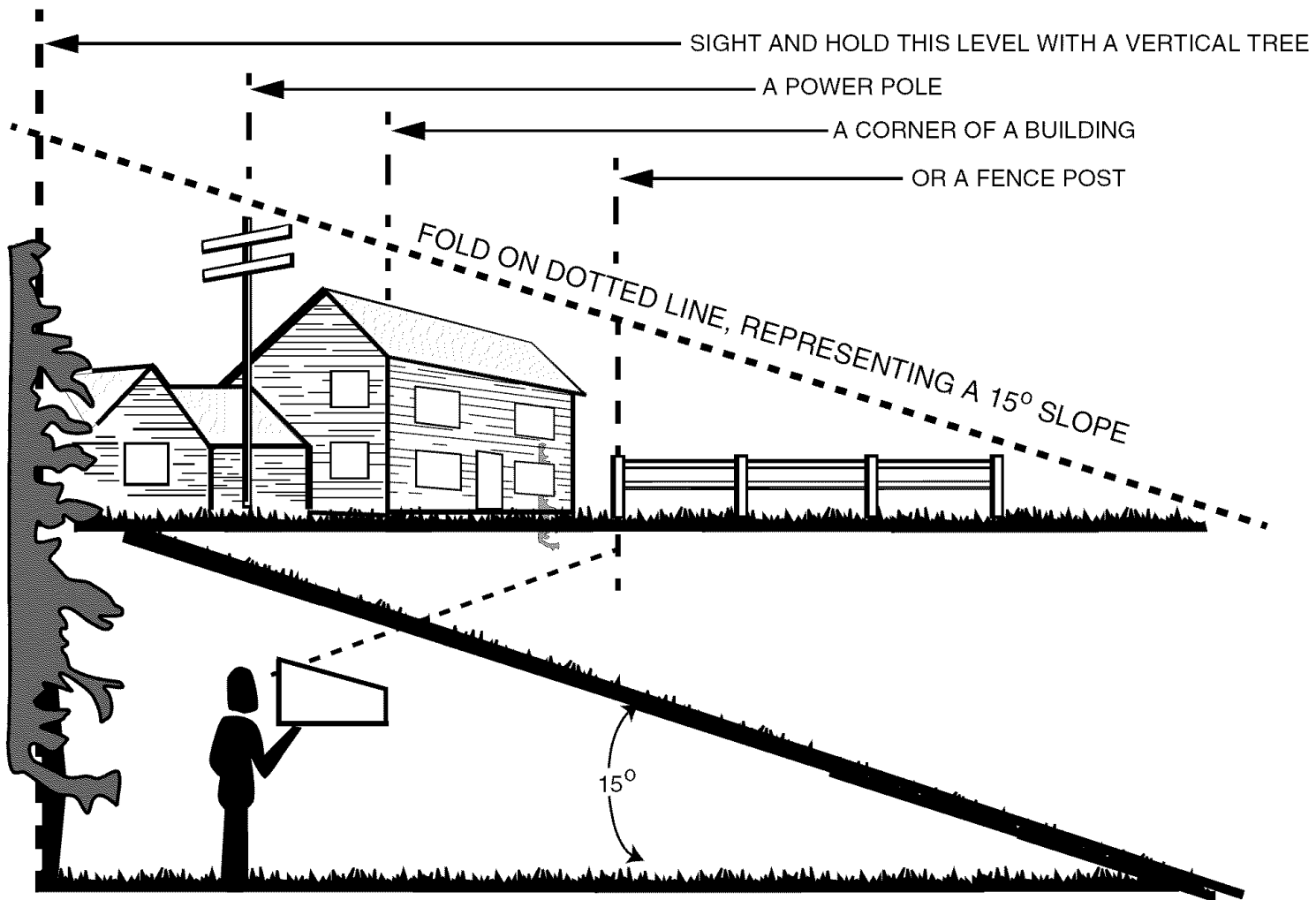

### WARNING

Do not mow on inclines with a slope in excess of 15 degrees (a rise of approximately 2-1/2 feet every 10 feet). A riding mower could overturn and cause serious injury. If operating a walk-behind mower on such a slope, it is extremely difficult to maintain your footing and you could slip, resulting in serious injury.

Operate RIDING mowers up and down slopes, never across the face of slopes.

Operate WALK-BEHIND mowers across the face of slopes, never up and down slopes.

## SECTION 3: ASSEMBLING YOUR LAWN MOWER

### Removing Unit From Carton

- Remove staples, break glue on top flaps, or cut tape at carton end and peel along top flap to open.
- Remove loose parts included with unit (i.e., operator's manual, oil, etc.).
- Cut corners and lay carton down flat. Remove packing material.
- Roll or slide unit out of carton. Check carton thoroughly for loose parts.

**NOTE:** Make sure not to crimp cables while removing loose parts or the entire unit from the carton.

### Tools Required

- Pair of Pliers
- Funnel

**NOTE:** Reference to right or left hand side of the mower and/or front or behind the mower is observed from the operating position.

### Hardware Pack

Please identify each piece of the hardware pack as shown in figure here.

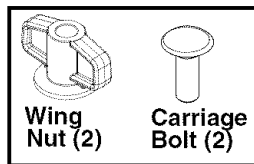

### Fresh Start™ Cartridge

### FreshStart™ Gas Cap

(Available on Model 569)



This unit is equipped with a FreshStart™ continuous fuel preserver gas cap which automatically drips continuous fuel preserver into your fuel tank for up to six months depending on conditions, such as temperature, usage patterns, fuel type and blend.

To activate the gas cap, follow the instructions below:

- Snap the fuel preserver cartridge that comes with your unit into the fuel cap.
- Peel off the white tab from the cartridge.
- Twist the FreshStart™ cap onto the fuel tank.

When you visually see that the fuel preserver cartridge is empty, replacement cartridges you may purchase through your local Troybilt service dealer

### Disconnecting Spark Plug

- Before setting up your lawn mower, disconnect the spark plug wire from the spark plug, and ground it against the engine.

### Assembling Handle

- Remove grass bag from the unit and set it out of the way. See Figure 1 (step 1).
- Remove any packing material which may be between the upper and lower handles for shipping purposes.

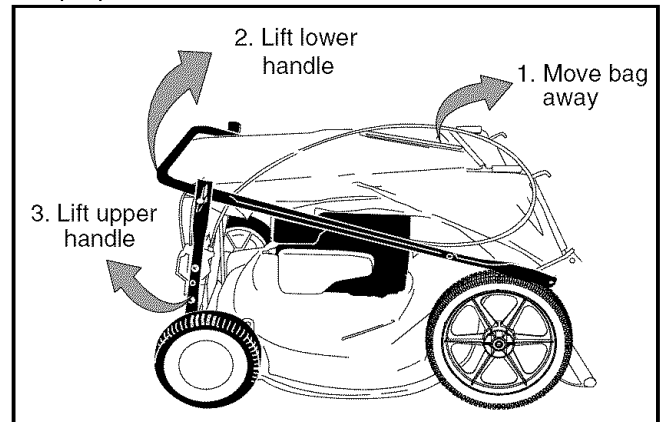

Figure 1

- Raise the lower handle in the direction shown in Figure 1 (step 2) till it snaps into place.
- Raise the upper handle in the direction shown in Figure 1 (step 3). Tighten the wing nuts which are already on the handle. See Figure 2 .

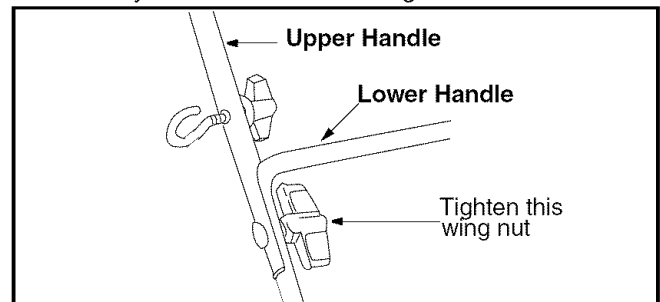

Figure 2

**NOTE:** Make sure to route the cables inside the lower handle. Also do not crimp the cables while lifting the handle up.

- For shipping purposes, the hairpin clip is placed in the outer hole of the weld pin on the lower handle. Remove the hairpin clip from the outer hole of the weld pin. See Figure 3.
- Using a pair of pliers, insert the hairpin clip into the inner hole on the weld pin. Repeat on other side. See Figure 3 .

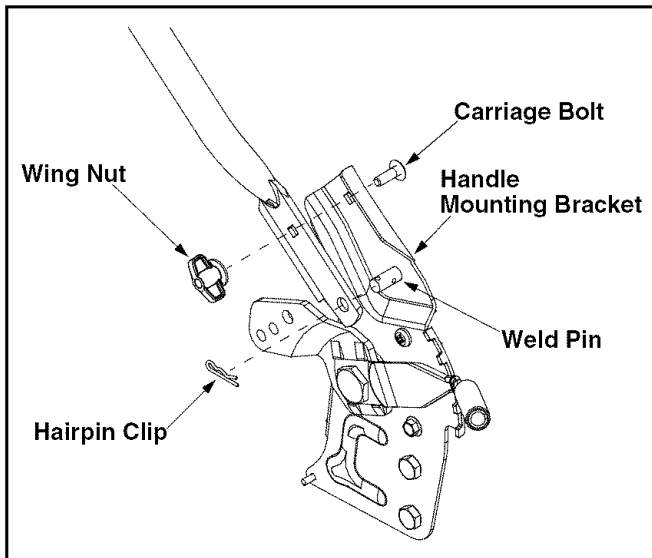

Figure 3

- Insert the carriage bolt, included in the hardware pack, in the upper hole on the handle mounting bracket (carriage bolt must go to the inside of handle). Secure with one plastic wing nut, also included in the hardware pack. Repeat on the other side with remaining items from the hardware pack.
- Attach cables to the lower handle with the two cable ties already on the lower handle. Pull cable ties tight and cut off the extra.

## Attaching Starter Rope

The rope guide is already attached to the right side of the upper handle of your mower. See Figure 4 .

- With spark plug wire disconnected and grounded, hold the blade control handle against the upper handle, and pull the starter rope out of the engine.
- Slip the rope through the rope guide as shown below. Tighten the wing nut holding the rope guide to the upper handle.

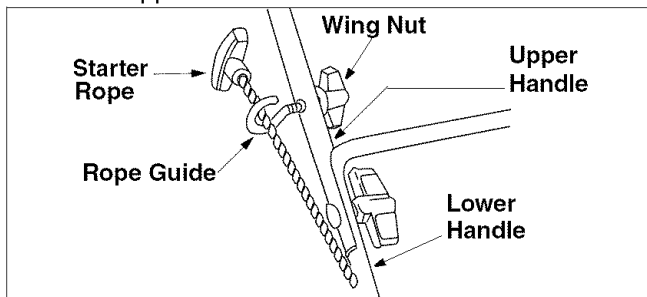

Figure 4

## Assembling Grass Catcher

**NOTE:** If the grass catcher came pre-assembled, proceed to the next section. If not, follow the steps below to assemble it before attaching to the mower.

- Insert frame into grass bag with the black plastic side on the bottom of bag. See Figure 5.

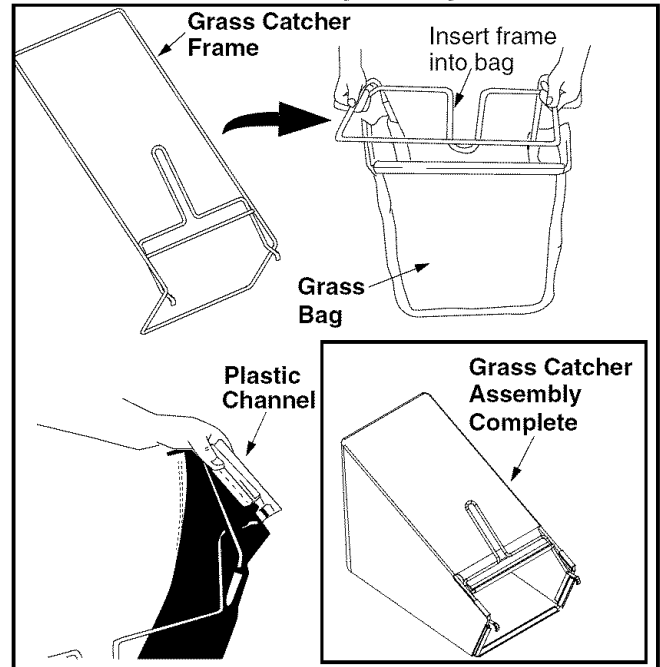

Figure 5

- Slip the openings in the side of the plastic channel on bag over the hooks on the grass catcher frame. Secure bag to the frame by working the six plastic channels on bag over frame. All of the plastic channels except the center top of the bag attach from the outside of bag. The center top of the bag attaches from inside the bag. See Figure 5.



**WARNING:** When using the mower to bag grass clippings, make sure the hooks on the grass catcher are firmly seated on the chute pivot rod, and the rear discharge door rests firmly against the top of the grass catcher.



## Attaching Grass Catcher

- Lift the rear discharge door and place the grass catcher on the pivot rod. Let go of discharge door so that it rests on the grass catcher. See Figure 6.

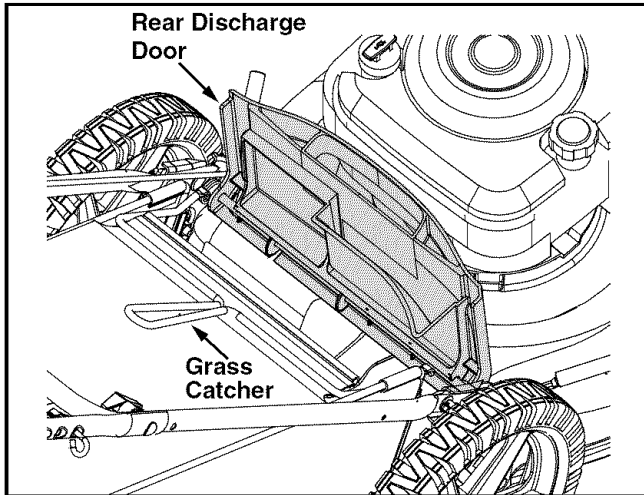

Figure 6

## Converting To Mulcher

- Lift the rear discharge door on the mower and lift the grass catcher up. Release the discharge door to allow it to close the rear opening of the mower.

## Converting To Side Discharge

- Make sure the grass catcher is off the unit and the rear discharge door is closed. Refer to Figure 7.
- On the side of the mower, lift the mulching plug. See Figure 7.
- Slide the two hooks of the side-discharge chute under the hinge pin on the mulching plug assembly. Lower the side mulching plug.
- Do not remove the side mulching plug at any time, even when you are not mulching.

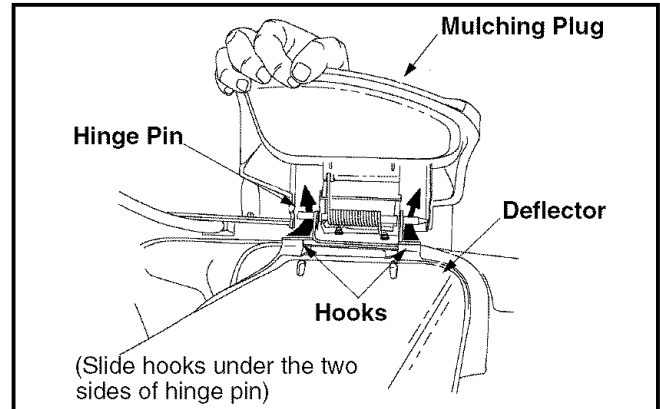

Figure 7

## SECTION 4: KNOW YOUR LAWN MOWER

Read this owner's manual and safety rules before operating your lawn mower. Compare the illustrations in Figure 8 with your lawn mower to familiarize yourself with the location of various controls and adjustments. Save this manual for future reference.

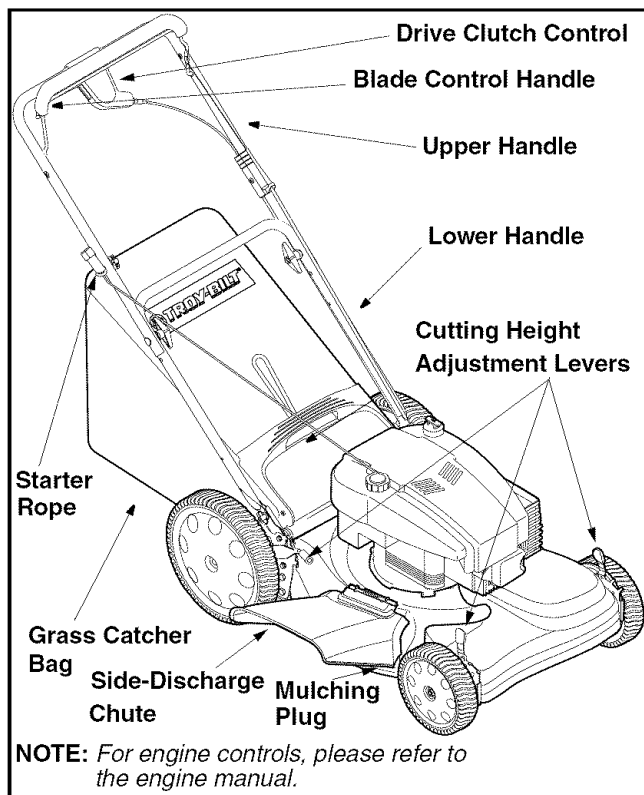

Figure 8

### Drive Clutch Control

The drive clutch control is located on the upper handle. Squeeze the drive control to engage the drive system. Release the clutch control to disengage the drive system. Release the clutch control to slow down when approaching an obstacle, making a turn, or stopping.

### Starter Rope

The starter rope is attached to the handle. Stand behind the unit and pull the starter rope to start the unit.

### Blade Control Handle

The blade control handle is located on the upper handle of the mower. The blade control handle must be depressed in order to operate the unit. Release the blade control handle to stop the engine and the blade.



**WARNING:** The blade control handle is a safety device. Never attempt to bypass its operations or alter it in any way.

### Grass Catcher Bag

The grass bag is used for collecting grass clippings. Attach it to the mower for this purpose, but remove it when the intention is to mulch the grass.

### Mulching Plug

The mulching plug is used only for mulching purposes. Instead of collecting the grass clippings in a grass catcher, your mower has the option of recirculating the clippings back to the lawn. Make sure that the rear discharge door is closed and the grass catcher is removed from the unit while mulching.

### Cutting Height Adjustment Lever

These levers are located on each wheel and they are used to adjust the cutting height. All four levers have to be at the same relative position to ensure uniform cut.



**WARNING:** The operation of any lawn mower can result in foreign objects being thrown into the operator's eyes thus causing severe eye damage. **Always wear safety glasses** while operating the mower, or while performing any adjustments or repairs on it.

---

## SECTION 5: OPERATING YOUR LAWN MOWER



**WARNING:** Read and understand all instructions and warnings on the machine and in this manual before operating.

### Gas & Oil Fill-Up

- Check oil level and add oil if necessary. Follow relevant instructions in the engine manual for this.
- Service the engine with gasoline as instructed in the engine manual.



**WARNING:** Use extreme care when handling gasoline. Gasoline is extremely flammable and the vapors are explosive. Never fuel the machine indoors or while the engine is hot or running. Extinguish cigarettes, cigars, pipes and other sources of ignition.

### Before Starting Mower

- Attach spark plug wire to spark plug. Make certain the metal cap on the end of the spark plug wire (inside the rubber boot) is fastened securely over the metal tip on the spark plug.
- Check for proper drive clutch operation using the neutral adjustment test described below:

#### Neutral Adjustment Test

To perform the neutral adjustment test answer the following questions:

- With the drive clutch control released, push mower forward and pull it backward. Does it move freely?
- Squeeze the drive clutch control and pull the mower backward. Do the rear wheels lock?
- Is the drive clutch control cable free of kinks or sharp bends?
- If you answered “yes” to all three questions, your mower passed the test and you can start it.
- If you answered “no” to any of the three questions, you will have to adjust the drive clutch control as instructed in the adjustment section.

### Throttle Speed

Your lawn mower engine is equipped with a constant speed throttle, which is set at full throttle for best performance.

### Starting Engine

- On **model 569**, push the primer three times. Wait about two seconds between each push. In cold weather around 55° F or below, prime five times. Do not prime to restart a warm engine after a short shutdown. **Model 566** has no primer and requires no priming.



**WARNING:** Be sure no one other than the operator is standing near the lawn mower while starting engine or operating mower.

**WARNING:** Never run engine indoors or in enclosed, poorly ventilated areas. Engine exhaust contains carbon monoxide, an odorless and deadly gas.

**WARNING:** Keep hands, feet, hair and loose clothing away from any moving parts on engine and lawn mower.

**WARNING:** When starting the unit for the first time, face the mower against a wall or a fence. Start the unit and if it shows any signs of motion while the drive clutch control is still disengaged, shut engine off immediately.

- Standing behind the mower, depress the blade control handle and hold it against the upper handle.
- Grasp starter handle and pull rope out slowly until engine reaches the start of compression cycle (rope will pull slightly harder at this point). Keeping a firm grip on the starter handle, let the rope rewind slowly.

**NOTE:** See your engine manual packed with your unit for more detailed instructions.

### To Stop Engine

- Release the blade control handle to stop the engine and blade.
- Disconnect spark plug wire and ground it against the engine to prevent accidental starting while equipment is unattended.

### Using Your Lawn Mower

- You can use your mower as a mulcher or a rear bagger or for side discharge of grass.
- Be sure that the lawn is clear of stones, sticks, wire, or other objects which could damage lawn mower or engine. Such objects could be accidentally thrown by the mower in any direction and cause serious personal injury to the operator and others.
- *For best results, do not cut wet grass* because it tends to stick to the underside of the mower.
- For a *healthy lawn*, always cut off one-third or less of the total length of the grass. Lawn should be trimmed in fall as long as there is growth.



**WARNING:** If the mower strikes a foreign object, stop the engine. Remove spark plug wire from the spark plug and thoroughly inspect for any damage. Repair the damage promptly before restarting and operating the mower.

## Mulching

For effective mulching, do not cut wet grass because it tends to stick to the underside of the deck, preventing proper mulching of grass clippings. New or thick grass may require a narrower cut. The ground speed should be adjusted to the condition of the lawn. If mowing has been delayed and the grass has been allowed to grow in excess of 4", mulching is not recommended. Mow using the grass bag to reduce the grass height to 3 1/4" maximum before mulching.

## Adjusting Cutting Height

Refer to height adjustments section of this manual on page 14 for instruction on how to adjust the cutting height and the handle height.

For best results in mowing, keep the cutting height position high until you can determine a suitable height.

## Bagging Grass Clippings

You can use the grass catcher bag to collect clippings while you are operating the mower.

- Attach grass catcher following instructions on page 9. Grass clippings will automatically collect in the bag as you run the mower. Operate the mower till the grass bag is full.
- Once the bag is full, stop the engine and the mower completely. Lift discharge door and pull grass bag up and away from the mower to dispose of the grass clippings.

---

## SECTION 6: MAINTAINING YOUR LAWN MOWER



**WARNING:** Always stop the engine and disconnect the spark plug wire before performing any maintenance work or adjustments on your lawn mower.



**WARNING:** Never tip the mower more than 90 degrees in any directions and do not leave the mower tipped for any length of time. Oil can drain into the upper part of the engine causing a starting problem.

## Cleaning Mower

The underside of the mower deck should be cleaned after each use to prevent any build-up of grass clippings, leaves, dirt, or other debris. If this debris is allowed to accumulate, it will result in rust and corrosion.

**NOTE:** *We do not recommend the use of pressure washers or garden hose to clean your unit. These may cause damage to electric components, spindles, pulleys, bearings, or the engine. The use of water will result in shortened life and reduce serviceability.*

- Disconnect spark plug wire.
- Drain the gasoline from the lawn mower, or place a piece of plastic under the gas cap.
- Tip the mower so that it rests on the housing. Keep the side with the air cleaner facing up. Hold the mower firmly.
- Scrape and clean the underside of the deck with a suitable tool. Do not spray with water.
- Put the mower back on its wheels on the ground. If you had put plastic under the gas cap, make sure to remove it now.

## Engine Care

A list of key maintenance jobs required for good performance by the mower is given below. Follow the accompanying engine manual for detailed list and instructions.

- Change engine oil regularly, as instructed in the engine manual. Check oil level before starting engine every time.
- Service air cleaner regularly. You may have to service this more frequently if you are operating the mower under extremely dusty conditions.
- Clean the engine periodically. Remove dirt and debris with a cloth or brush.
- Clean the spark plug and reset the gap to .030" at least once a season. Refer to the engine manual for correct spark plug type.
- Inspect muffler periodically, and replace if necessary. Damaged mufflers or spark arresters can create a fire hazard.



**WARNING:** Avoid muffler and surrounding areas while the mower engine is hot because temperature of these areas of the engine may exceed 150° F.

## Lubrication

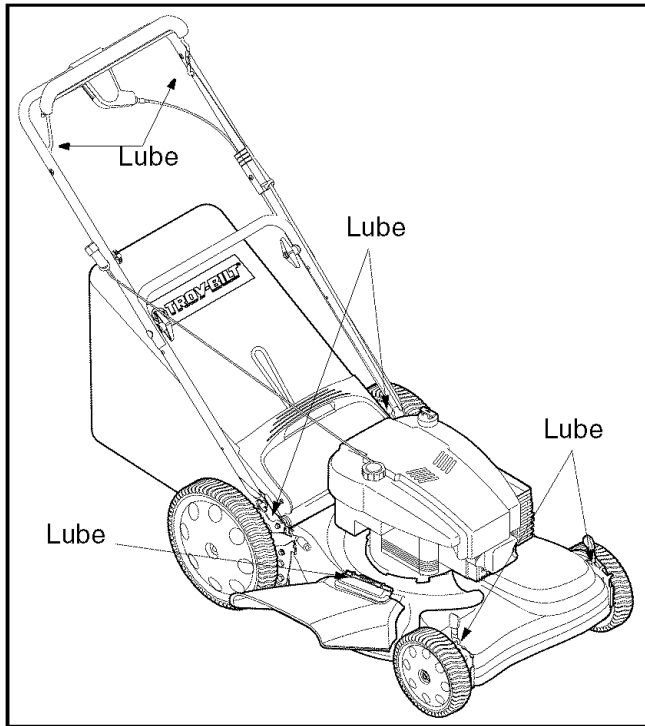

Figure 9: Lubrication Chart

### Wheels

- Lubricate the wheels and bearings, if so equipped, at least once a season with light oil or engine oil. Also, if the wheels are removed for any reason, lubricate the surface of the axle and the inner surface of the wheel with light oil.

### Mulch Plug & Rear Discharge Door

- Lubricate the torsion spring and the pivot point on each end of the rear discharge door using a light oil.

### Transmission

- The transmission is pre-lubricated and sealed at the factory and does not require lubrication on a regular basis as part of maintenance.

### Blade Control

- Lubricate the pivot points on the blade control handle and the brake cable at least once a season with a light oil. It needs to move in both directions.

### Engine

- Follow the engine manual instructions and recommended schedule for lubricating engine components.

## Blade Care

- Periodically inspect the blade adapter and pulley for cracks, especially if you strike a foreign object. Replace when necessary.



**WARNING:** When removing the cutting blade for sharpening or replacement, protect hands by using heavy gloves or a thick rag to grasp the cutting blade.

- Disconnect spark plug wire from spark plug.

- Turn mower on its side making sure that the air filter and the carburetor are up.

### To Remove Blade:

- Remove the hex bolt which holds the blade adapter-pulley assembly to the engine crankshaft. See Figure 10. Remove the pulley assembly and the bell support from the crankshaft.
- Remove blade from the blade adapter and pulley.

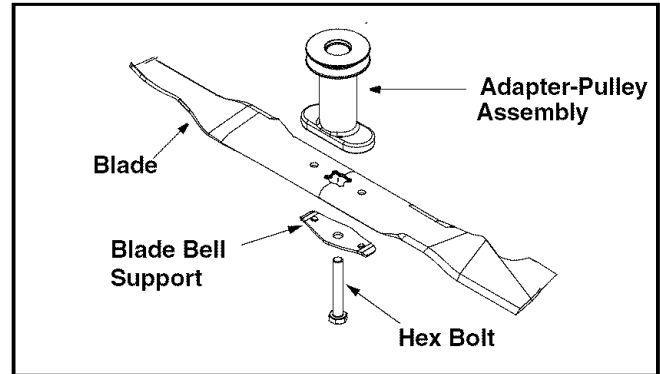

Figure 10

### To Replace Blade:

- Before reinstalling the blade-pulley assembly to the unit, lubricate the engine crankshaft and the inner surface of the blade adapter with light oil.
- Also lubricate the bolt hole and the hex bolt.
- Insert the hex bolt, earlier removed, through the center holes on the blade bell support and the blade adapter-pulley assembly respectively.
- Install the blade assembly on the crankshaft. Tighten the hex bolt to the recommended torque.

### Blade Mounting Torque:

Center bolt: 450 in.lbs. minimum, 600 in.lbs. maximum.

**IMPORTANT:** The bolt used to secure the blade to the engine is specially heat-treated. **Do not substitute.** To order replacement bolt, refer to the parts list in the back of this manual.



**WARNING:** To ensure safe operation of your unit, all nuts and bolts must be checked periodically for correct tightness.

### To Sharpen Blade:

- The blade can be sharpened with a file or on a grinding wheel. Do not attempt to sharpen the blade while it is still on the mower.
- Follow the original angle of grind as a guide. Make sure that each cutting edge receives an equal amount of grinding to prevent an unbalanced blade.

**NOTE:** An unbalanced blade will cause excessive vibration when rotating at high speeds, may cause damage to the mower and could break, causing personal injury. Test the blade by balancing it on a round shaft screwdriver or a blade balancer.

- If the blade is not balanced, remove metal from the heavy side until it balances evenly.

## SECTION 7: SERVICE & ADJUSTMENTS

### Replacing Drive Belt

- Remove two shoulder screws securing the front drive cover to the mower deck. See Figure 11.

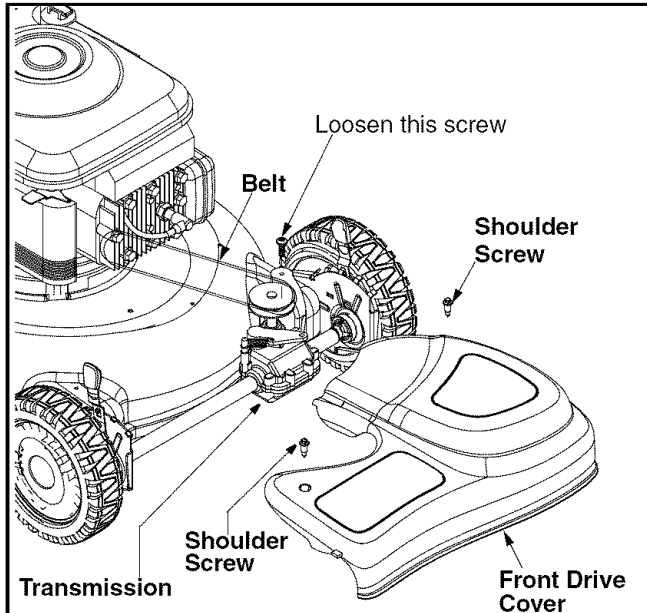

Figure 11

- Press inward on the sides of the front drive cover and release the tabs that secure the front drive cover to the height adjuster brackets. Remove drive cover from the mower.
- Using a torx wrench, loosen the screw holding the belt tension spring to the transmission. See Figure 11. Do not remove the screw completely. As you loosen the screw, tension on the belt will release.
- Push the transmission up a little and slide the belt off the transmission pulley.
- Lift the mower to access the belt from the underside of the mower.



**WARNING:** Use a thick piece of rag to handle the blade while sliding the belt in the next step. Make sure the engine does not start at all while doing this job.

- Slide the belt off the engine pulley and around the blade. See Figure 12 .
- Replace with the new belt, working around the blade. Make sure the belt is firmly seated on the engine pulley while pulling from the other side and sliding it around the transmission pulley.
- Put the mower down with all four wheels firmly placed on one level.

- Tighten the screw, loosened earlier, to secure the belt tension spring to the transmission, and reassemble the front drive cover.

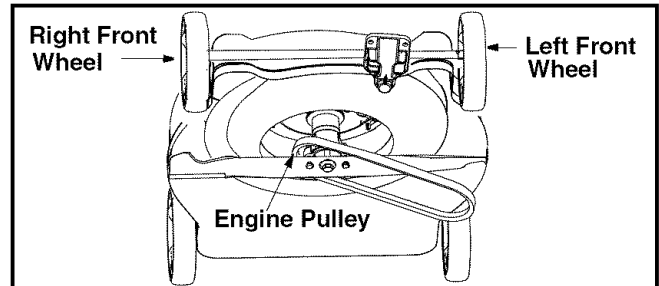

Figure 12

### Replacing Rear Flap

- To remove rear flap, cut off the flat end of the wire rod which secures it to the deck. See Figure 13 .
- Attach the new flap and new rod to deck, bending the ends of the new rod over to secure to deck.

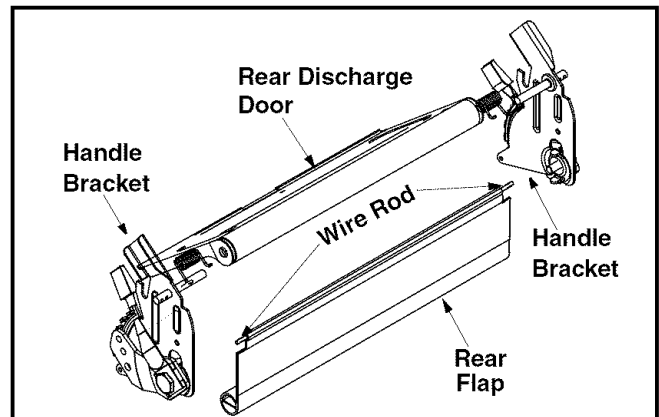

Figure 13

### Adjusting Cutting Height

**IMPORTANT:** All wheels must be placed in the same relative position. For rough or uneven lawns, move the height adjustment lever to a higher position. This will help stop scalping of the grass.

An adjusting plate and thumb lever at each wheel provides cutting height adjustment. Each adjusting plate has nine height positions. Height of cut will be changed when you move the thumb lever from one position to another.

- Simply depress the lever towards the wheel and move the lever assembly to desired position. See Figure 14 .
- For rough or uneven lawns, move the height adjustment handles to higher cutting height position

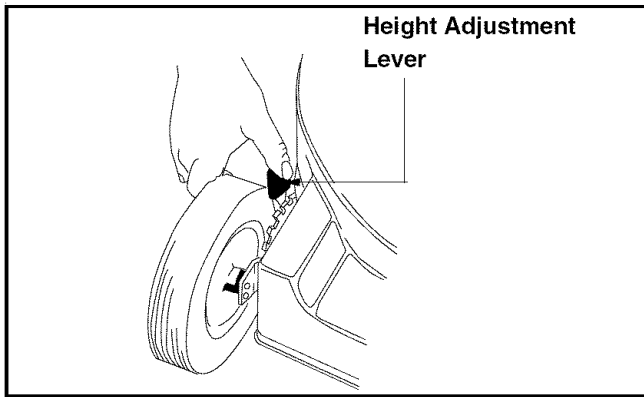

Figure 14

## Drive Clutch Control

The adjustment wheel is located in the drive clutch control handle housing and is used to tighten or loosen the drive belt. You will have to adjust the drive clutch control if any of the following happens:

1. The mower does not propel itself with the drive clutch engaged;
2. The mower's drive wheels hesitate with the drive clutch engaged.

To resolve the above problems, rotate the adjustment wheel clockwise to tighten the cable and counterclockwise to loosen the cable. See Figure 15.

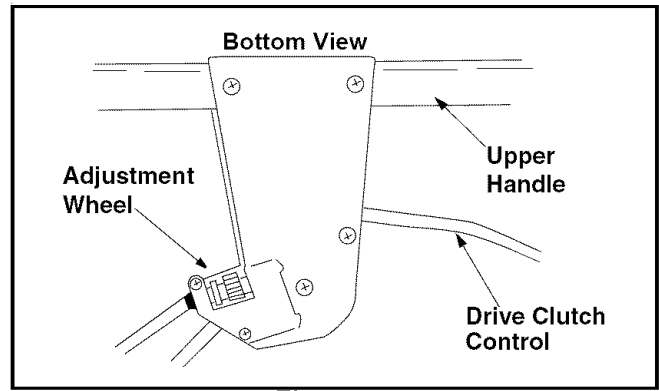

Figure 15

**NOTE:** For some people the drive clutch control may not be in a comfortable position. You can adjust the handle by tightening the adjustment wheel.

## Engine Adjustments

See the engine manual for adjustments to the engine.

## Adjusting Carburetor

If the engine is running rough, minor adjustments to the carburetor may be required to compensate for differences in fuel, temperature, altitude and load.

**NOTE:** Dirty air cleaner may cause an engine to run rough. Before adjusting carburetor, check air cleaner.

To adjust the carburetor, please follow the recommendations and instructions on carburetor adjustment in the engine manual.



**WARNING:** If any adjustments are made to the engine (e.g. carburetor) while the engine is running, keep clear of all moving parts. Be careful of heated surfaces like the muffler.

## SECTION 8: OFF-SEASON STORAGE

Prepare your lawn mower for storage at the end of the season or if the unit will not be used for 30 days or more. Store the mower in a clean, dry area.

### Mower

- Clean underside of the mower following instructions in the Maintain Your Lawn Mower section of this manual.
- Lubricate mower as instructed on page 11.
- You can fold your mower's handle for convenient storage: Remove the starter rope from the rope guide; loosen the two hand knobs on the sides of the handle, and let the upper handle fold down to the rear. Move the hairpin clips to the outer hole in

the weld pins on the handle mounting brackets. Spread the sides of the lower handle, and push it forward and down.

- Inspect and replace/sharpen blade, if required.

### Engine

**IMPORTANT:** It is important to prevent gum deposits from forming in essential fuel system parts such as the carburetor, fuel filter, fuel hose, or tank during storage. Also, alcohol blended fuels (called gasohol or using ethanol or methanol) can attract moisture which leads to separation and formation of acids during storage. Acidic gas can damage the fuel system of an engine while in storage.

**NOTE:** Fuel stabilizer is an acceptable alternative to emptying the tank of fuel in minimizing the formation of fuel gum deposits during storage.

- Add stabilizer to gasoline in fuel tank (on model 569 if FreshStart™ fuel preserver cartridge is empty) or storage container.
- Do not drain the gas tank and carburetor if using fuel stabilizer.

In all cases, drain all the oil from the crankcase (this should be done after the engine has been operated and is still warm) and refill the crankcase with fresh oil.

When you visually see that the fuel preserver cartridge is empty(model 569), replacement cartridges are available through your local Troybilt Service Dealer.

If you do not use FreshStart™ or other fuel stabilizer, follow these instructions:

- Drain the fuel from the tank by running the engine until the fuel tank is empty.
- Remove spark plug, pour approximately 1/2 ounce (approximately one tablespoon) of engine oil into cylinder and crank slowly to distribute oil.
- Replace spark plug.
- Follow recommendations in the engine manual for off-season storage of the engine.
- Clean engine and remove any grass clippings.

### Other

- Do not store gasoline from one season to another.
- Replace your gasoline can if it starts to rust. Rust and/or dirt in the gasoline will cause problems. Store unit in a clean, dry area. Do not store next to corrosive materials, such as fertilizer.

**NOTE:** If storing in an unventilated or metal storage shed, be certain to rustproof the equipment by coating with a light oil or silicone.

## SECTION 9: TROUBLE-SHOOTING

Problem	Possible Cause	Corrective Action
Engine fails to start	<ol style="list-style-type: none"> <li>1. Blade control handle disengaged</li> <li>2. Spark plug wire disconnected</li> <li>3. Fuel tank empty, or stale fuel</li> <li>4. Blocked fuel line</li> <li>5. Faulty spark plug</li> <li>6. Engine flooded</li> </ol>	<ol style="list-style-type: none"> <li>1. Engage blade control handle.</li> <li>2. Connect wire to spark plug.</li> <li>3. Fill up tank with fresh gasoline.</li> <li>4. Clean fuel line.</li> <li>5. Clean, adjust gap, or replace.</li> <li>6. Wait a few minutes to restart, Do not prime.</li> </ol>
Engine runs erratic	<ol style="list-style-type: none"> <li>1. Spark plug wire loose</li> <li>2. Blocked fuel line or stale fuel</li> <li>3. Vent in gas cap plugged</li> <li>4. Water or dirt in fuel system</li> <li>5. Dirty air cleaner</li> </ol>	<ol style="list-style-type: none"> <li>1. Connect and tighten spark plug wire.</li> <li>2. Clean fuel line, fill tank with fresh gasoline.</li> <li>3. Clear vent.</li> <li>4. Drain fuel tank. Refill with fresh fuel.</li> <li>5. Clean air cleaner. Refer to engine manual.</li> </ol>
Engine overheats	<ol style="list-style-type: none"> <li>1. Engine oil level low</li> <li>2. Air flow restricted</li> </ol>	<ol style="list-style-type: none"> <li>1. Fill crankcase with proper oil.</li> <li>2. Clean lawn mower engine.</li> </ol>
Occasional skip (hesitates) at high speed	<ol style="list-style-type: none"> <li>1. Spark plug gap too close</li> </ol>	<ol style="list-style-type: none"> <li>1. Adjust gap to .030 inches.</li> </ol>
Idles poorly	<ol style="list-style-type: none"> <li>1. Spark plug faulty, or gap too wide</li> <li>2. Dirty air cleaner</li> </ol>	<ol style="list-style-type: none"> <li>1. Reset gap to .030 inches or replace spark plug.</li> <li>2. Clean air cleaner.</li> </ol>
Excessive vibration	<ol style="list-style-type: none"> <li>1. Blade loose or unbalanced</li> <li>2. Bent cutting blade</li> <li>3. Bent engine crankshaft</li> </ol>	<ol style="list-style-type: none"> <li>1. Tighten blade and adapter, balance blade.</li> <li>2. Replace blade.</li> <li>3. Contact the nearest service center</li> </ol>
Mower will not mulch grass	<ol style="list-style-type: none"> <li>1. Wet grass</li> <li>2. Excessively high grass</li> <li>3. Dull blade</li> </ol>	<ol style="list-style-type: none"> <li>1. Wait until grass is dry to cut.</li> <li>2. Mow once at a high cutting height, then mow again at desired height.</li> <li>3. Sharpen or replace blade.</li> </ol>
Uneven cut	<ol style="list-style-type: none"> <li>1. Wheels not at same height</li> <li>2. Dull blade</li> </ol>	<ol style="list-style-type: none"> <li>1. Reposition all wheels at same height.</li> <li>2. Sharpen or replace blade.</li> </ol>

**NOTE:** For repairs beyond the minor adjustments listed above, contact your local authorized service dealer.



# NOTES

# SECTION 10: PARTS LIST FOR MODEL SERIES 566 & 569

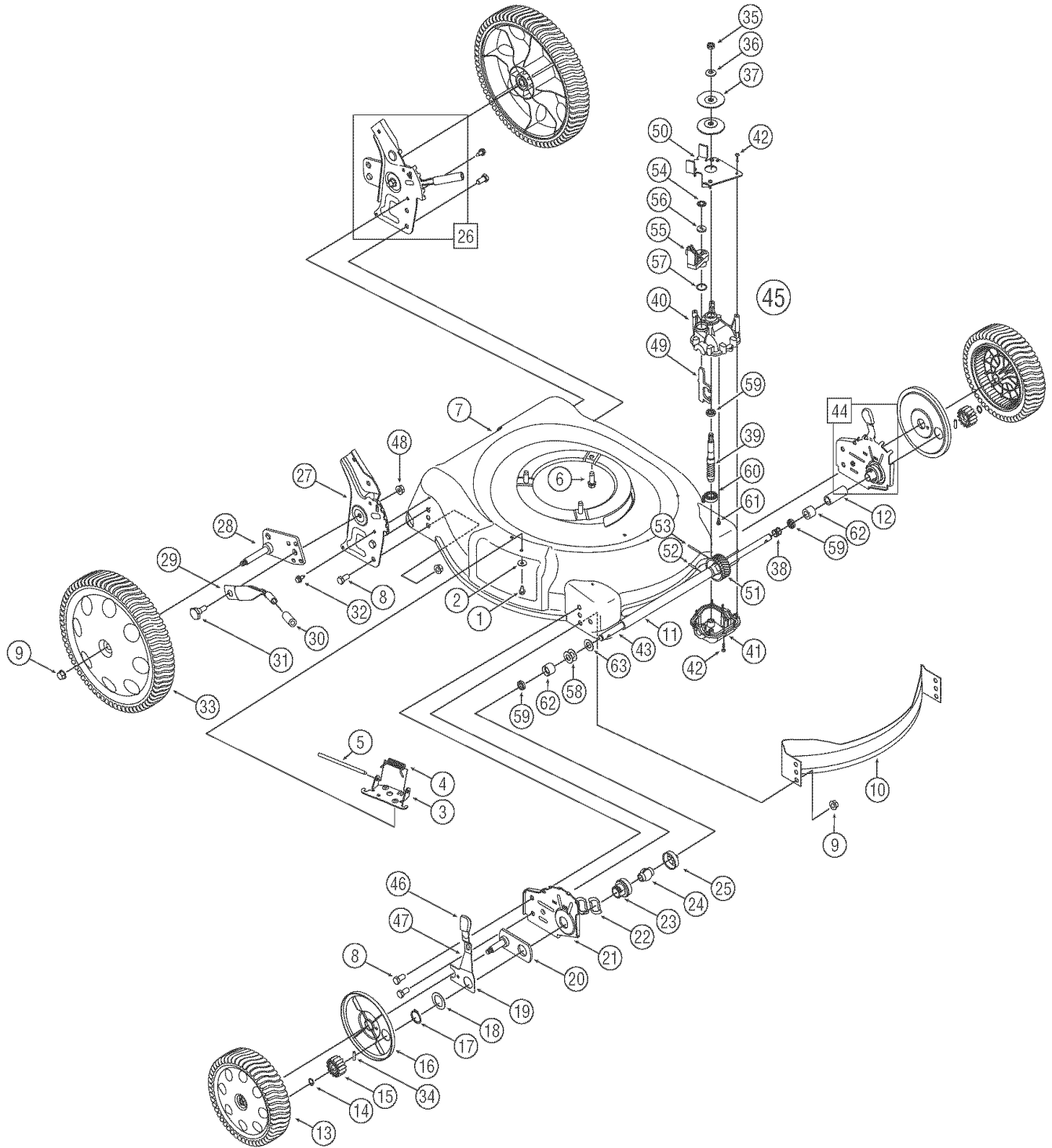

## Model Series 566 & 569

Ref. No	Part No.	Description	Ref. No	Part No.	Description
1.	710-0599	TT Screw 1/4-20 x 0.5	31.	738-0507B	Shoulder Scr.500 Dia. x.434
2.	736-0270	Bell Washer.265 x 0.75	32.	710-1652	Tt Screw 1/4-20 x.625"
3.	17032A	Deflector Chute Adapter	33.	734-04127	Wheel, 12 x 2.125
4.	732-1014	Torsion Spring	34.	715-0221	Dowel Pin
5.	747-0710	Hinge Pin	35.	712-0116	Hex Jam Nut 5/16-24
6.	710-0654A	Self-Tapping Sems Screw	36.	736-0105	Bell Washer.325 x.930 x.45
7.	787-01222	21" Deck	37.	756-04132	Pulley, 3.82 x.313 x.68
8.	710-0216	Hex Screw 3/8-16 x.75	38.	732-04273	Compression Spring
9.	712-0431	Hex Nut 3/8-16	39.	711-04317	Pinion Shaft
10.	782-5002B	Front Baffle	40.	731-05099	Upper Housing
11.	750-04404	Sleeve Spacer 9.10" Lg.	41.	731-04883	Lower Housing
12.	750-04405	Slev. Spacer 1.5" Lg.	42.	710-04329	Torx Screw
13.	734-04018A	Wheel 8 x 2.125 Gear	43.	711-04304	Output Shaft
14.	716-0865	Snap Ring	44.	682-0511A	Height Adjustment Assembly LH
15.	717-1762	Gear 14T RH FWD		682-0512A	Height Adjustment Assembly RH*
	717-1761	Gear 14T LH FWD *	45.	618-04274	Transmission Assembly Comp.*
16.	782-7551A	Wheel Dust Cap	46.	720-0426	Adjustment Knob
17.	716-0102	Snap Ring	47.	732-0706	Front Lever RH
18.	736-0474	Washer		732-0707	Front Lever LH*
19.	687-02018	Lever Assembly RH	48.	712-3005	Hex Flange Lock Nut 3/8-16
20.	687-02044	Pivot Plate Assembly	49.	707-04409	Shifter Fork
21.	782-0512B	Height Adjuster Plate - RH	50.	707-04567	Transmission Bracket
	782-0511A	Height Adjuster Plate - LH*	51.	717-04194	28 Tooth Gear
22.	736-0447	Wave Washer	52.	715-0129	Spirol Pin
23.	748-0355	Bearing Support	53.	415-04030	Dowel Pin
24.	741-0604A	Bearing Sleeve	54.	726-04043	Push Nut
25.	732-0708	Bearing Retainer	55.	731-05187	Clutch Lever
26.	687-02057	Handle Bracket Assembly - LH	56.	736-04178	Slotted Washer
	687-02056	Handle Bracket Assembly - RH*	57.	721-04110	O-ring
27.	687-02033	Handle Bracket - RH	58.4	736-04170	Flat Washer
	687-02031	Handle Bracket - LH*	59.	721-04107	Oil Seal
28.	687-02039	Pivot Bar RH	60.	741-04116	Ball Bearing
	687-02040	Pivot Bar LH*	61.	710-04374	Hex Screw
29.	732-0866	Height Adjustment Lever	62.	741-04106	Plastic Bushing
30.	720-0312	Foam Grip	63.	436-0572	Flat Washer

\*Not Pictured in Illustration

# Model Series 566 & 569

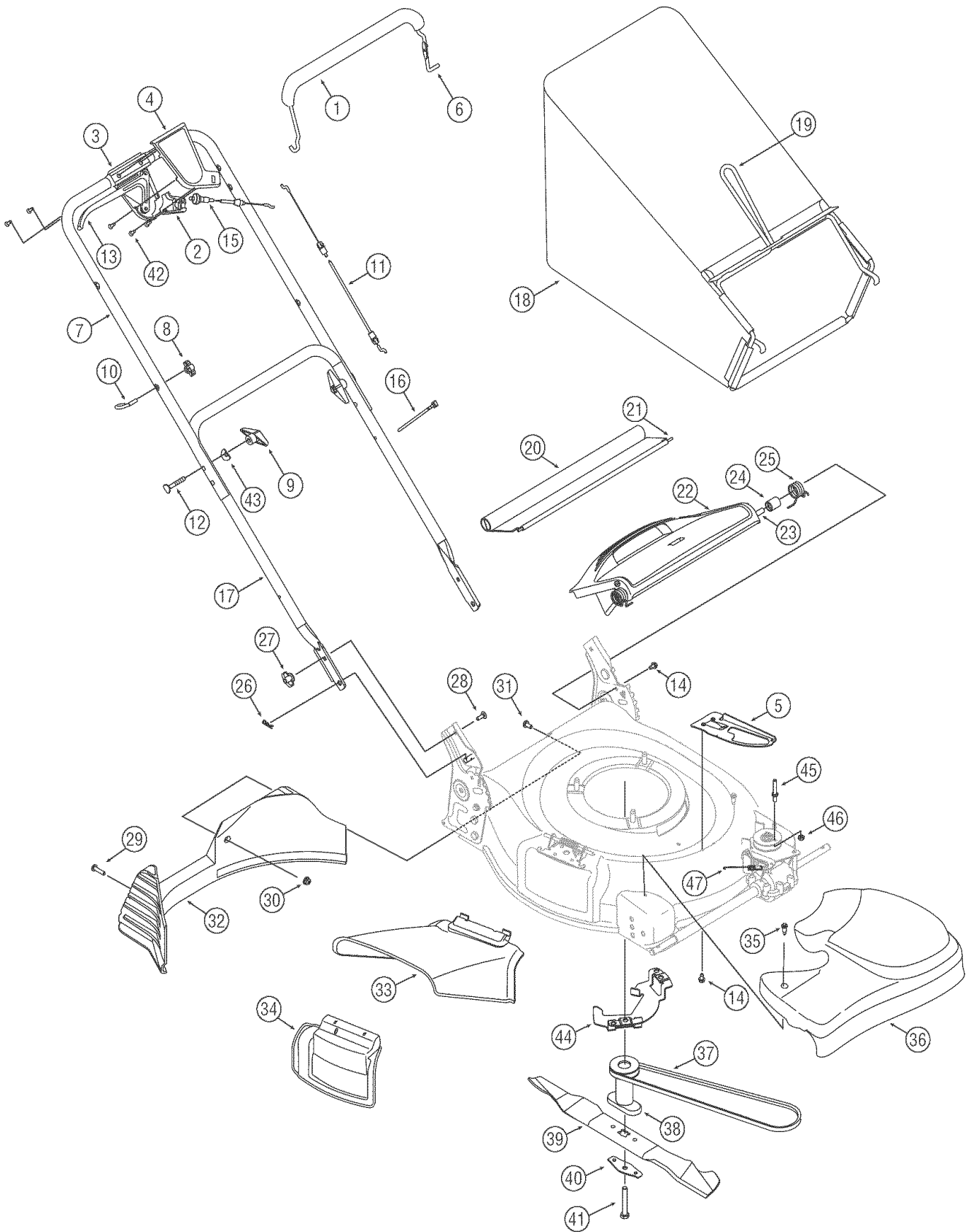

# Model Series 566 & 569

Ref. No	Part No.	Description	Ref. No	Part No.	Description
1.	731-04204	Deluxe Bail Cover	25.	732-04089A	Torsion Spring LH
2.	731-1059	Cable Mounting Cap		732-04090A	Torsion Spring RH
3.	731-1058	Control Cover Lower Half	26.	714-0104	Cotter Pin
4.	731-1057	Control Cover Upper Half	27.	712-0397	Wing Nut
5.	787-01258	Cable Mount Bracket	28.	710-0703	Carriage Bolt 1/4-20
6.	747-1161A	Blade Control Handle	29.	710-0286	Machine Screw 1/4-20
7.	749-04206	Upper Handle	30.	712-04064	Flange Lock Nut 1/4-20
8.	720-0279	Handle Knob	31.	710-04371	HL Screw 1/4-15
9.	720-0284	Handle Knob	32.	731-04150	Rear Baffle 21" Rd.
10.	710-1205	Eye Bolt	33.	731-04177	Chute Deflector
11.	746-0957	Control Cable 37.25"	34.	687-02055	Mulch Plug Comp.
12.	710-1174	Carriage Bolt 5/16-18 x 2.0	35.	710-1650	Shoulder Screw # 12 -24
13.	731-0620	Drive Control Lever	36.	731-05020	Transmission Cover
14.	710-0599	TT Screw 1/4-20 x 0.5	37.	754-04082	V-Belt
15.	746-04206	Drive Cable	38.	748-04015A	Blade Adapter w/ Pulley
16.	726-0240	Cable Tie	39.	742-0741	21" Mulching Blade
17.	749-0928A	Lower Handle	40.	736-0524B	Blade Bell Support
18.	664-04011	Grassbag Assembly	41.	710-1257	Hex Screw 3/8-24 x 2.50
19.	747-04080	Grass Bag Frame	42.	710-1667A	HL Screw #10-16
20.	731-04998	Rear Trailing Shield	43.	736-0451	Saddle Washer
21.	732-0700	Wire	44.	687-02150	Belt Keeper Engine Bracket
22.	731-04134A	Rear Discharge Door	45.	711-0993	Belt Guard Pin 1/4 x 1.43
23.	747-0996	Pivot Rod	46.	712-3055	Hex Lock Nut 1/4 x 20
24.	750-04162	Spacer.375 x.50 x 1.02	47.	732-04286	Extension Spring

**IMPORTANT:** For a proper working machine, use Factory Approved Parts. **V-BELTS** are specially designed to engage and disengage safely. A substitute (non OEM) V-Belt can be dangerous by not disengaging completely.

# NOTES

## NOTES;

# MANUFACTURER'S LIMITED WARRANTY FOR:



The limited warranty set forth below is given by Troy-Bilt LLC with respect to new merchandise purchased and used in the United States, its possessions and territories.

"Troy-Bilt" warrants this product against defects in material and workmanship for a period of two (2) years commencing on the date of original purchase and will, at its option, repair or replace, free of charge, any part found to be defective in materials or workmanship. This limited warranty shall only apply if this product has been operated and maintained in accordance with the Operator's Manual furnished with the product, and has not been subject to misuse, abuse, commercial use, neglect, accident, improper maintenance, alteration, vandalism, theft, fire, water, or damage because of other peril or natural disaster. Damage resulting from the installation or use of any part, accessory or attachment not approved by Troy-Bilt for use with the product(s) covered by this manual will void your warranty as to any resulting damage.

Normal wear parts are warranted to be free from defects in material and workmanship for a period of thirty (30) days from the date of purchase. Normal wear parts include, but not limited to items such as: batteries, belts, blades, blade adapters, grass bags, rider deck wheels, seats, snow thrower skid shoes, shave plates, auger spiral rubber and tires.

**HOW TO OBTAIN SERVICE:** Warranty service is available, WITH PROOF OF PURCHASE, through your local authorized service dealer. To locate the dealer in your area, check your Yellow Pages, or contact Troy-Bilt LLC at P.O. Box 361131, Cleveland, Ohio 44136-0019, or call 1-866-840-6483 or 1-330-558-7220, or log on to our Web site at [www.troybilt.com](http://www.troybilt.com).

This limited warranty does not provide coverage in the following cases:

- a. The engine or component parts thereof. These items may carry a separate manufacturer's warranty. Refer to applicable manufacturer's warranty for terms and conditions.
- b. Log splitter pumps, valves, and cylinders have a separate one year warranty.
- c. Routine maintenance items such as lubricants, filters, blade sharpening, tune-ups, brake adjustments, clutch adjustments, deck adjustments, and normal deterioration of the exterior finish due to use or exposure.
- d. Service completed by someone other than an authorized service dealer.
- e. Troy-Bilt does not extend any warranty for products sold or exported outside of the United States, its possessions and territories, except those sold through Troy-Bilt's authorized channels of export distribution.
- f. Replacement parts that are not genuine Troy-Bilt parts.
- g. Transportation charges and service calls.

**No implied warranty, including any implied warranty of merchantability of fitness for a particular purpose, applies after the applicable period of express written warranty above as to the parts as identified. No other express warranty, whether written or oral, except as mentioned above, given by any person or entity, including a dealer or retailer, with respect to any product, shall bind Troy-Bilt. During the period of the warranty, the exclusive remedy is repair or replacement of the product as set forth above.**

**The provisions as set forth in this warranty provide the sole and exclusive remedy arising from the sale. Troy-Bilt shall not be liable for incidental or consequential loss or damage including, without limitation, expenses incurred for substitute or replacement lawn care services or for rental expenses to temporarily replace a warranted product.**

Some states do not allow the exclusion or limitation of incidental or consequential damages, or limitations on how long an implied warranty lasts, so the above exclusions or limitations may not apply to you.

In no event shall recovery of any kind be greater than the amount of the purchase price of the product sold. **Alteration of safety features of the product shall void this warranty.** You assume the risk and liability for loss, damage, or injury to you and your property and/or to others and their property arising out of the misuse or inability to use the product.

This limited warranty shall not extend to anyone other than the original purchaser or to the person for whom it was purchased as a gift.

**HOW STATE LAW RELATES TO THIS WARRANTY:** This limited warranty gives you specific legal rights, and you may also have other rights which vary from state to state.

**IMPORTANT:** Owner must present Original Proof of Purchase to obtain warranty coverage.

**Troy-Bilt LLC, P.O. BOX 361131 CLEVELAND, OHIO 44136-0019; Phone: 1-866-840-6483, 1-330-558-7220**