

Installation Instructions

Under-the-Cabinet Microwave Oven

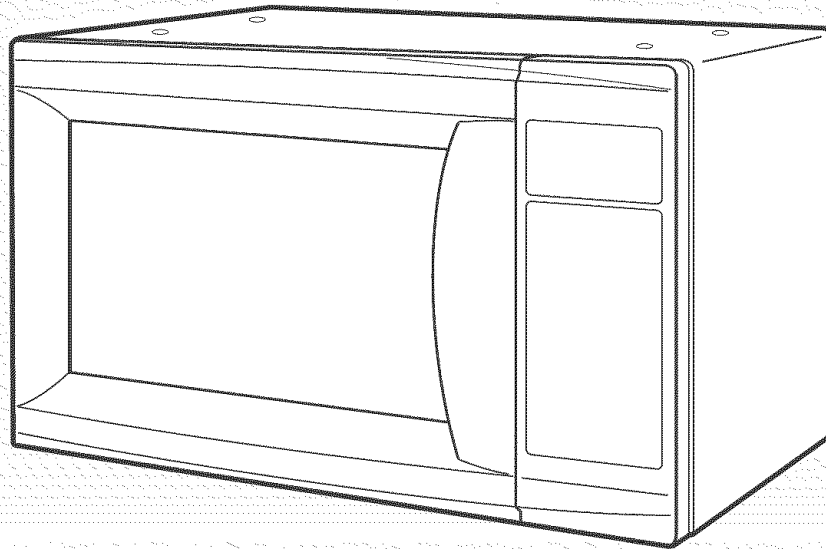

Quick Reference

Table of Contents:

Pages

- | | |
|---|-------------------------|
| 2 | Before you start |
| 2 | Product dimensions |
| 2 | Location |
| 3 | Electrical requirements |
| 3 | Installation steps |

IMPORTANT: Read and save these instructions.

www.whirlpool.com

IMPORTANT:

Installer: Leave Installation Instructions with the homeowner.

Homeowner: Keep Installation Instructions for future reference.

Read and save these instructions for local electrical inspector's use.

For quick reference, please record the following:

Model Number _____

Serial Number _____

Model/Serial plate located on the oven behind the door.

Date of Purchase _____

Dealer _____ Phone No. _____

Part No. 8204864/3828W5U0311

Before you start...

Your safety and the safety of others are very important.

We have provided many important safety messages in this manual and on your appliance. Always read and obey all safety messages.



This is the safety alert symbol.

This symbol alerts you to potential hazards that can kill or hurt you and others.

All safety messages will follow the safety alert symbol and either the word "DANGER" or "WARNING." These words mean:

DANGER

You can be killed or seriously injured if you don't immediately follow instructions.

WARNING

You can be killed or seriously injured if you don't follow instructions.

All safety messages will tell you what the potential hazard is, tell you how to reduce the chance of injury, and tell you what can happen if the instructions are not followed.

You need to:

- ✓ observe all governing codes and ordinances.
- ✓ install microwave oven as specified in these instructions or as specified on upper cabinet template.
- ✓ have everything you need to properly install microwave oven.
- ✓ check the microwave oven for damage. If any damage is evident, do not operate the microwave oven until it is checked by an authorized service technician.
- ✓ place a portion of carton or other heavy material between the microwave oven and the floor or countertop. Do not use a plastic cover.
- ✓ remove shipping materials and parts from inside the microwave oven. Locate templates and set them aside to be used later.
- ✓ make sure the microwave oven will be mounted against and supported by upper cabinet or other horizontal structure.
- ✓ support for an additional weight of 90 lbs (41 kg), which includes microwave oven and items placed in the oven.

Tools recommended for installation:

Assemble the required tools and parts before starting installation. Read and follow the instructions provided with any tools listed here.

- Phillips screwdriver
- electric drill
- 1/2" drill bit
- 1/2" wood bit or metal hole cutter (if metal cabinet is used)
- protective covering, such as a blanket for microwave and countertop (you may also use carton for protection)
- scissors
- pencil
- measuring tape
- masking tape or similar
- center punch
- hammer

Parts included for Installation:

the installation hardware items are in a small bag packed below the oven.

- 4 – 1-3/8" mounting screws
- 4 – 2-3/8" mounting screws
- 2 – mounting holders
- 8 – 1/4" spacers
- template

Location

NOTE: This microwave oven is intended for installation over a countertop. Do not install this microwave oven above any heat source such as a range or cooktop.

Check the cabinet:

The cabinet must be a minimum of 12" (30.5 cm) deep. The bottom shelf of your cabinet must be at least 3/16" (4.8 mm) thick and strong enough to support an additional weight of 90 lbs (41 kg).

NOTE: This weight is in addition to the normal contents of the cabinet, as well as any other objects hung from the bottom of the cabinet.

To provide for adequate ventilation, do not install the microwave closer than 2-9/16" (6.5 cm) to a side wall.

Product dimensions

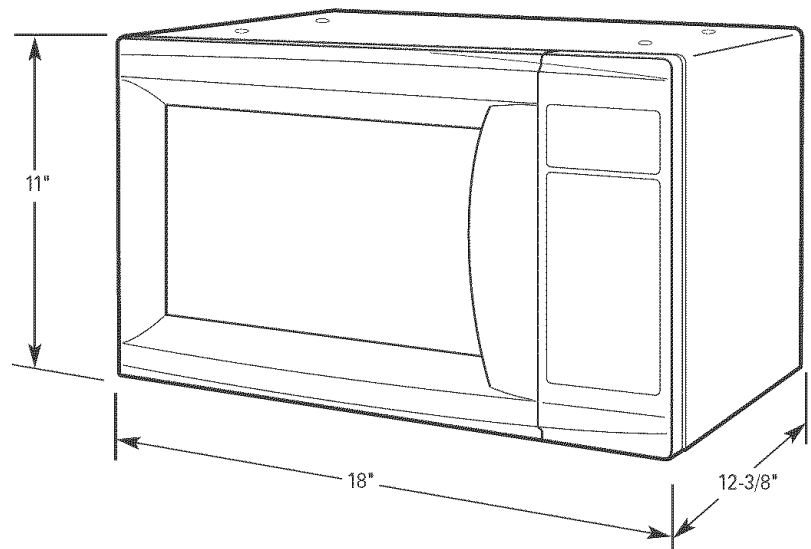

Electrical requirements

⚠ WARNING



Electrical Shock Hazard

Plug into a grounded 3 prong outlet.
Do not remove ground prong.
Do not use an adapter.
Do not use an extension cord.
Failure to follow these instructions can result in death, fire, or electrical shock.

IMPORTANT: Observe all governing codes and ordinances.

It is the customer's responsibility:

To assure that the electrical installation is adequate and in conformance with National Electrical Code, ANSI/NFPA 70 — latest edition*, and all local codes and ordinances.

You must have:

- ✓ 120-volt, 60Hz, AC-only, 15 or 20 amp, fused (or circuit breaker) grounded electrical supply.
- ✓ outlet located as close as possible to the microwave oven.

We recommend:

- ✓ a time-delay fuse or circuit breaker.
- ✓ a separate circuit serving this appliance only.

If codes permit and a separate ground wire is used, it is recommended that a qualified electrician determine that the ground path is adequate.

Recommended ground method

For your personal safety, this appliance must be grounded. This appliance is equipped with a power supply cord having a 3 prong ground plug. To minimize possible shock hazard, the cord must be plugged into a mating 3 prong ground-type wall outlet, grounded in accordance with the National Electrical Code, ANSI/NFPA 70 — latest edition*, and all local codes and ordinances.

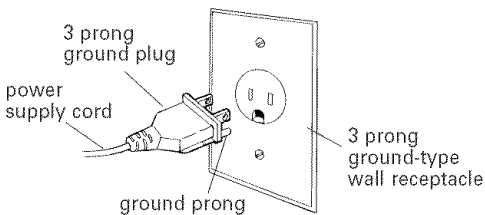

Copies of the standards listed may be obtained from:

* National Fire Protection Association
One Batterymarch Park
Quincy, Massachusetts 02269

Installation steps

⚠ WARNING

Excessive Weight Hazard

Use two or more people to move and install microwave oven.
Failure to do so can result in back or other injury.

1. Remove contents from the bottom shelf of your cabinet.

2. Location of template: Select the easiest position to work from, either on the inside bottom of the cabinet or the underside of the cabinet to locate the template.

When putting the template in place, make sure the front of the cabinet is directly above the front of the microwave oven cabinet, not the microwave oven door.

Go to "Template instructions" on next page.

3. Once the template is in place and taped down, use a center punch, or a nail, to mark the position of the 4 holes, as shown on the template. Remove the template.

4. Drill 4 holes through the cabinet at the marked locations, using a 1/2" (12.7 mm) drill bit.

5. Remove the four plugs from top of microwave oven cabinet. Be sure to save these plugs. If the microwave oven is used later as a countertop model, these plugs will need to be replaced.

6. If the cabinet has a front frame extending below cabinet bottom go to Step 6a.

If the cabinet does not have a front frame extending below the cabinet bottom go to Step 6b.

6a. If the cabinet has a front frame extending below cabinet:

Measure the distance from the bottom of the cabinet to the bottom of the front frame, to determine which of the mounting screws provided, (short or long) and how many of the spacers provided, will need to be used to install the oven properly.

Slide the correct number of spacers on the back mounting screws only.

Distance "A"	Number of spacers
0 - 1/2" (0 - 12.7 mm)	0 - 2
1/2" - 3/4" (12.7 mm - 19.1 mm)	2 - 3
3/4" - 1" (19.1 mm - 25.4 mm)	3 - 4

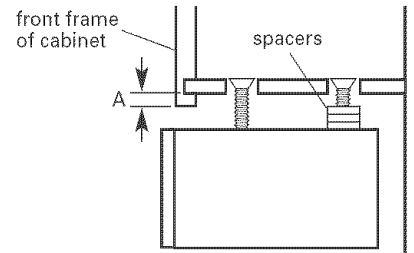

Insert each screw into a threaded hole in the top of the oven. Turn each screw three or four times to start the screw into the threaded hole

6b. If the cabinet does not have a front frame extending below the cabinet bottom:

Slide one spacer over each of the four mounting screws or, for a smaller gap, use 1/4" I.D. flat washers available from hardware store.

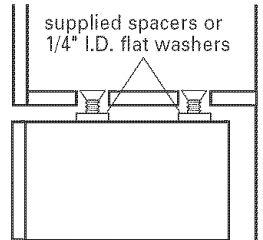

Insert each screw into a threaded hole in the top of the oven. Turn each screw three or four times to start the screw into the threaded hole.

7. Lift the microwave oven so the mounting screws enter into the four holes in the bottom of the cabinet. Slide the mounting holders onto the necks of the mounting screws.

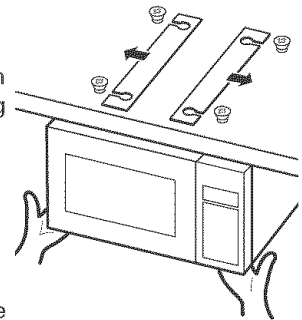

8. Slowly tighten the four screws evenly until the oven is completely secure and level.

9. Plug power supply cord into a grounded 3 prong outlet.

To get the most efficient use from your under-the-cabinet microwave oven, read your Use and Care guide.

Template instructions

Drilling from inside the cabinet

If you cannot drill from inside the cabinet, see "Drilling from under the cabinet" section.

If the cabinet does not have a partition or you are not installing under two adjoining cabinets:

Place template inside the cabinet so that the front line of the Template A will be aligned with the front edge of the cabinet. If necessary, cut some areas of the template in order to make it fit properly within cabinet.

See **NOTE** at bottom of page.

If the cabinet has a partition or you are installing under two adjoining cabinets:

1. Cut Template B from template A along the dotted line.
2. Cut Template A into two pieces to fit each side of the partition.
3. Position one piece of Template A inside cabinet making sure the front line is aligned with the front edge of the cabinet. Tape in place.

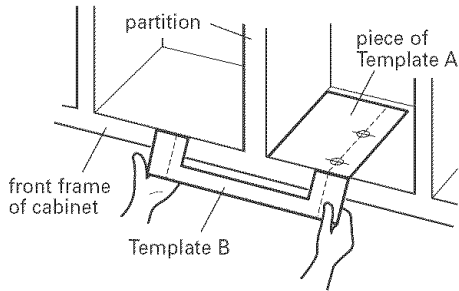

4. Position Template B in front of the cabinet so that the hole centerline is aligned with the hole centerline of the Template A piece positioned in Step 3 above.
5. Position the other piece of Template A inside the adjacent cabinet opening so that the hole centerline aligns with the hole centerline on Template B. Tape in place. If you have followed the instructions properly, the distance between the right and left hole centerlines will be 12-7/8" (32.7 cm).

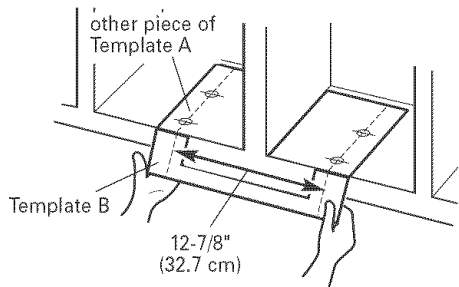

See **NOTE** to right.

Drilling from under the cabinet

If the cabinet does not have a front frame extending below the cabinet, there is no partition, or you are not installing under two adjoining cabinets:

Tape Template A to the underside of cabinet so the front line of template will be aligned with the front edge of the cabinet. If necessary, cut some areas of the template in order to make it fit properly on the underside of cabinet.

See **NOTE** at bottom of page.

If cabinet has only a front frame extending below the cabinet bottom and no partition:

Measure the thickness of the frame. Fold template along guide line that matches the frame thickness. Place the folded edge of template against the back side of front frame on the underside of the cabinet. Tape in place.

See **NOTE** at bottom of page.

If the cabinet has a partition, you are installing under two adjoining cabinets, or there is a side frame as shown:

1. Cut Template B from template A along the dotted line.
2. Cut Template A into two pieces to fit each side of the partition or adjoining cabinets.
3. Position one piece of Template A under cabinet making sure the front line is positioned against the back side of front frame on the underside of the cabinet. Tape in place.

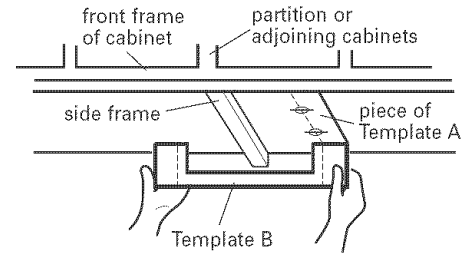

4. Position Template B toward the rear of the cabinet so that the hole centerline is aligned with the hole centerline of the Template A piece positioned in Step 3 above.
5. Position the other piece of Template A under the adjacent cabinet opening so that the hole centerline aligns with the hole centerline on Template B. Tape in place. If you have followed the instructions properly, the distance between the right and left hole centerlines will be 12-7/8" (32.7 cm).

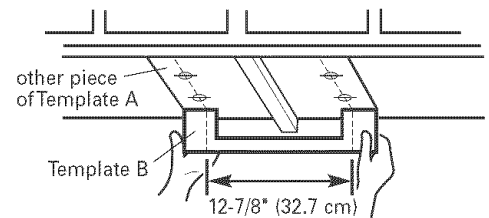

See **NOTE** below.

NOTE: For any of the template instructions used, when Template A is properly installed, the distance from the front edge of the cabinet with cabinet door(s) open to the centerlines of the front holes will be 2-1/16" (5.2 cm).

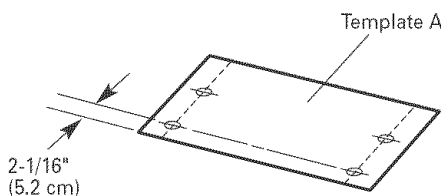

Return to Step 3 of "Installation steps."