

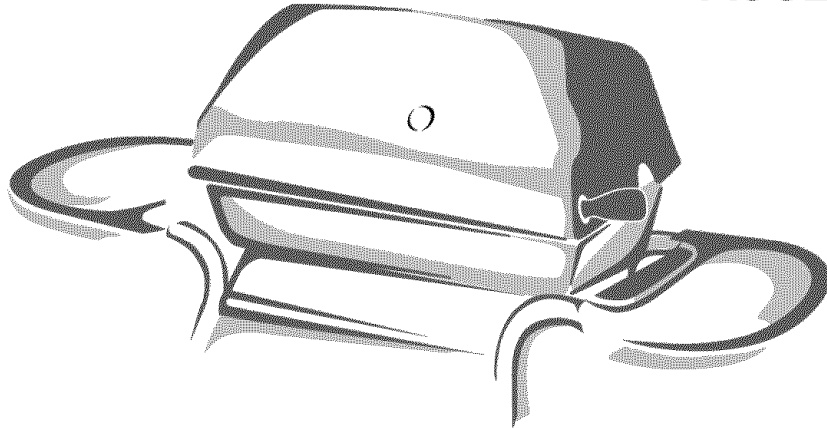

Liquid Propane Gas Grill

Model No. 415.161110

This Grill Is For
Outdoor Use Only



WARNING

- Read this manual before cooking on grill. Failure to follow all manufacturers' instructions could result in fire or explosion which could cause property damage, personal injury or death.
- Combustion by-products produced when using this product contain chemicals known to the State of California to cause cancer, birth defects, or other reproductive harm.

- Parts
- Assembly
- Safety Rules
- Use and Care
- Troubleshooting
- Español, p. 33

CAUTION

- Read and follow all Safety Statements, Assembly Instructions and Use & Care Directions before attempting to assemble and cook.
- Some parts may contain sharp edges, especially as noted in these instructions. Wear protective gloves if necessary.

Assembly Questions?
Call 1-800-241-7548

Parts Ordering:
Call 1-800-4-MY-HOME®

To Installer/Assembler: Leave these instructions with consumer.

To Consumer: Keep this manual for future reference.

463351605 / 0-7000959 (01-14-05)

 **WARNING** 

FOR YOUR SAFETY

1. Do not store or use gasoline or other flammable vapors and liquids in the vicinity of this or any other appliance.
2. An LP tank not connected for use shall not be stored in the vicinity of this or any other appliance.

FOR YOUR SAFETY

If you smell gas:

1. Shut off gas to the appliance.
2. Extinguish any open flame.
3. Open lid.
4. If odor continues, immediately call your gas supplier or your fire department.

Call Grill Service Center For Help And Parts

If you have questions or need assistance during assembly, please call **1-800-241-7548**. You will be speaking to a representative of the grill manufacturer and not a Sears employee. To order new parts call Sears at **1-800-4-MY-HOME®**.



Product Record

IMPORTANT: Fill out the product record information below.

Model Number _____

Serial Number _____
See rating label on grill for serial number.

Date Purchased _____

 **CAUTION** 

For residential use only. Do not use for commercial cooking.

Safety Symbols

The symbols and boxes shown below explain what each heading means. Read and follow all of the messages found throughout the manual.

 **DANGER** 

DANGER: Indicates an imminently hazardous situation which, if not avoided, will result in death or serious injury.

 **WARNING** 

WARNING: Be alert to the possibility of serious bodily injury if the instructions are not followed. Be sure to read and carefully follow all of the messages.

 **CAUTION** 

CAUTION: Indicates a potentially hazardous situation which, if not avoided, may result in minor or moderate injury.

Installation Safety Precautions

- Use grill only with LP (propane) gas and the regulator/valve assembly supplied.
- Grill installation must conform with local codes, or in their absence with **National Fuel Gas Code, NFPA 54 / ANSI Z223.1**. Handling and storage of LP cylinders must conform to LP Gas Code **NFPA/ANSI 58**. Grill is not for use in or on recreational vehicles and/or boats.
- All electrical accessories (such as rotisserie) must be electrically grounded in accordance with local codes, or **National Electrical Code, ANSI / NFPA 70**. Keep any electrical cords and/or fuel supply hoses away from any hot surfaces.
- This grill is safety certified for outdoor use in the United States only. Do not modify for use in any other location. Modification will result in a safety hazard.

TABLE OF CONTENTS

For Your Safety	2
Grill Service Center	2
Product Record Information	2
Safety Symbols	2
Installation Safety Precautions	2
Kenmore Grill Warranty	3
Parts List	4
Parts Diagram	5
Assembly	6-16
Use and Care	17-23
Cooking Table	24
Troubleshooting	25-27

Repair Protection Agreements

Congratulations on making a smart purchase. Your new Kenmore® product is designed and manufactured for years of dependable operation. But like all products, it may require repair from time to time. That's when having a Repair Protection Agreement can save you money and aggravation.

Purchase a Repair Protection Agreement now and protect yourself from unexpected hassle and expense.

Here's what's included in the Agreement:

- Expert service** by our 12,000 professional repair specialists
- Unlimited service and no charge** for parts and labor on all covered repairs
- Product replacement** if your covered product can't be fixed
- Discount of 10%** from regular price of service and service-related parts not covered by the agreement; also, 10% off regular price of preventive maintenance check
- Fast help by phone** – phone support from a Sears technician on products requiring in-home repair, plus convenient repair scheduling

Once you purchase the Agreement, a simple phone call is all that it takes for you to schedule service. You can call anytime day or night, or schedule a service appointment online.

Sears has over 12,000 professional repair specialists, who have access to over 4.5 million quality parts and accessories. That's the kind of professionalism you can count on to help prolong the life of your new purchase for years to come. Purchase your Repair Protection Agreement today!

Some limitations and exclusions apply.

For prices and additional information call 1-800-827-6655.

Sears Installation Service

For Sears professional installation of home appliances, garage door openers, water heaters, and other major home items, in the U.S.A. call 1-800-4-MY-HOME®

WARRANTY

KENMORE GRILL WARRANTY

Full 1-Year Warranty on Grill

For one year from the date of purchase Sears will repair or replace, at our option, any grill part (except for paint finish) that is defective in material or workmanship.

Limited Warranty on Selected Grill Parts

From one year after the date of purchase for the designated time periods listed below, Sears will replace the following grill parts if they are defective in material or workmanship. You will be charged for labor.

- Lifetime of Grill: Aluminum Top and Bottom Castings (except for paint finish)
- 2 years: Burner Assembly

WARRANTY SERVICE

Warranty service is available by contacting Sears at

1-800-4-MY-HOME®.

WARRANTY RESTRICTIONS

This warranty is void if grill is used for commercial or rental purposes.

This warranty applies only when the grill is used in the United States.

This warranty gives you specific legal rights, and you may also have other rights which vary from state to state.

Sears, Roebuck and Co., Dept. 817WA,
Hoffman Estates, IL 60179

PARTS LIST – Model No. 415.161110

<u>Key</u>	<u>Qty</u>	<u>Description</u>	<u>Part #</u>	<u>Key</u>	<u>Qty</u>	<u>Description</u>	<u>Part #</u>
1	2	Leg Assembly	7000865	25	1	Ignitor Wire	7000893
2	1	Bottom Shelf	7000506	26	2	Shelves	7000291
3	25	#10-16x1/2" Self-Tap Screw	7000737 STD611005	27	1	Top Casting	7000654
4	2	Leg Extender	7000320	28	1	Bezel Temperature Gauge	4157169
5	3	"U" Nut 1/4-20	7000185	29	1	Temperature Gauge w/Wing Nut	4157171
6	1	1/4-20 x 6" Tank Thumbscrew	7000355	30	1	Logo Plate Assembly	4157167
7	1	1/4-20 Flanged Hex Nut	7000394	31	2	Shoulder Bolt	7000186
8	2	#10-24x1/2" Washer Head Screw	7000829	32	3	Control Knob	7000312
9	1	Axle Rod	7000265	33	1	Condiment Basket	7000242
10	2	Wheel	7000262	34	3	Vaporizer Tents	7000044
11	4	Rail	7000652	35	3	Cooking Grid, 8"x15".	7000027
12	1	Heat Shield	7000388	36	1	Warming Rack	7000180
13	1	Front Panel	7000897	37	1	Handle	7000199
14	5	Push Fastener	4080112	38	2	#10-24 Wing Nut	4080063 STD541610
15	1	Grill Bottom	7000846	39	1	Ignitor Button w/Battery	7000162
16	1	Carry-Over Tube	7000278	40	1	Grease Tray	7000042
17	2	Pal Nut	7000132	41	1	Grease Pan	7000046
18	2	Casting Bumper	7000184				
19	3	Burner	7000083				
20	4	#10-1" Self-Tap Screw	4080716				
21	1	Electrode w/Wing Nut	7000378				
22	1	Control Panel	7000863				
23	1	Valve/Hose/Regulator Assembly	7000335				
24	1	Ignitor Module	7000160				

PARTS DIAGRAM – Model No. 415.161110

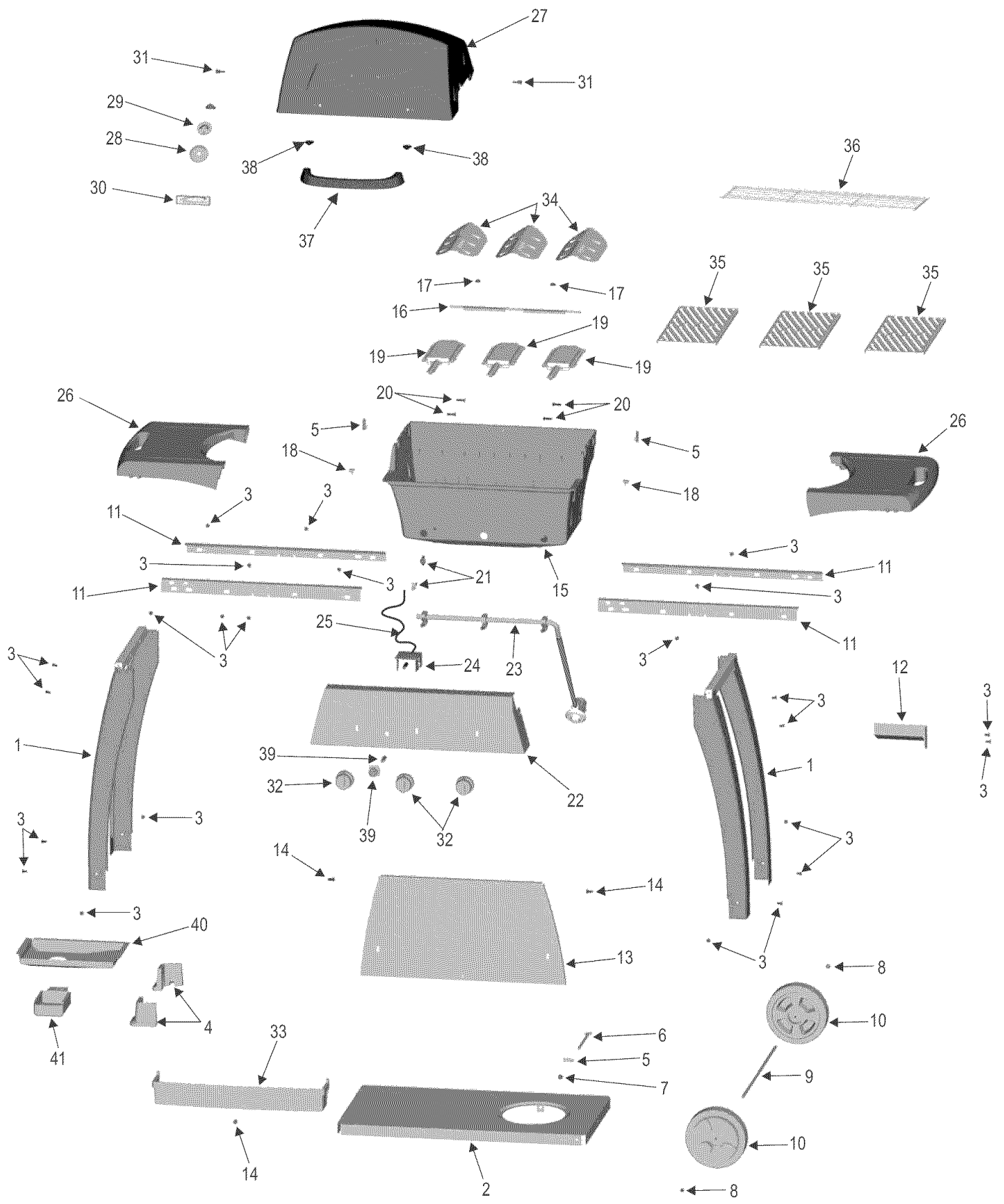

ASSEMBLY – Model No. 415.161110

Use included Phillips head screwdriver to assemble your grill.

Size and type of hardware used in assembly of your grill may vary, but will not affect grill integrity, performance or assembly.

“NEW”

T. L. M. - Torque Locking Method

① ② ③

Screw + Thru Part + Formed Lock = Solid Lock Cart Structure

- The cart assembly utilizes the new T.L.M. fastening method.
- No need for the old style “Bolt & Nut” combination

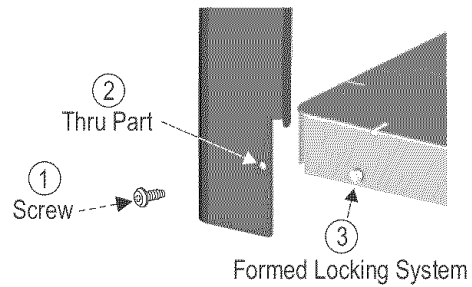

1

Cart Assembly

- Place bottom shelf on table or grill container.
- Insert tabs on leg assemblies into left and right sides of bottom shelf.
- Attach leg assemblies with one screw on each side.

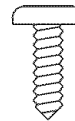

3

Qty:8

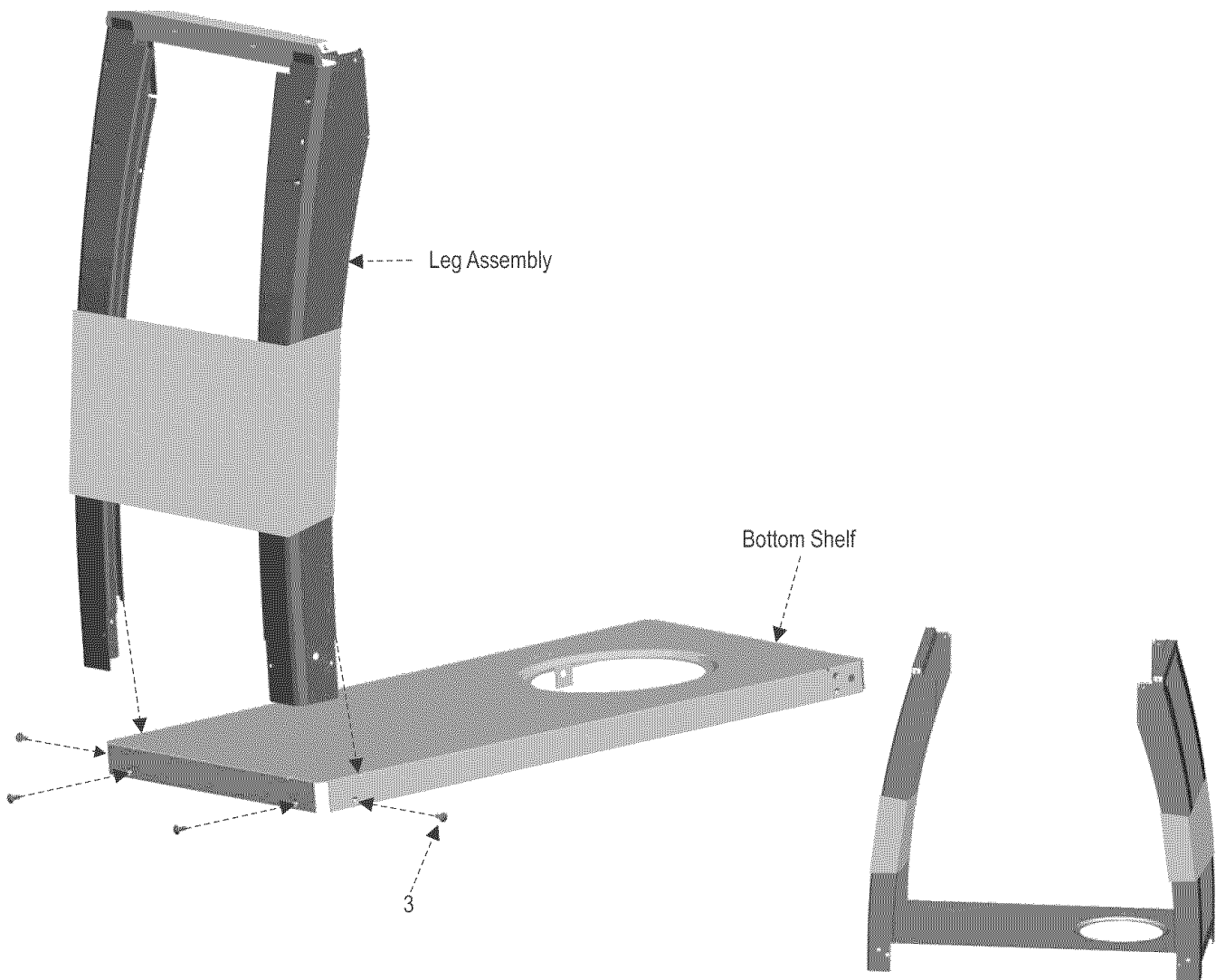

Correctly assembled legs

2

Leg Extenders, Axle Rods, Wheels and Tank Thumbscrew

- Turn cart upside down.
- Insert leg extenders. Check to make sure leg extender is all the way into the leg.
- Attach u-nut to tab. See enlargement of u-nut for correct position.
- Thread tank thumbscrew into hole and u-nut. Screw flanged hex nut onto end of tank thumbscrew.
- Attach washer head screw to axle rod. Slide wheel on axle rod. Insert axle rod/wheel into large hole in bottom shelf. Attach other wheel and washer head screw.

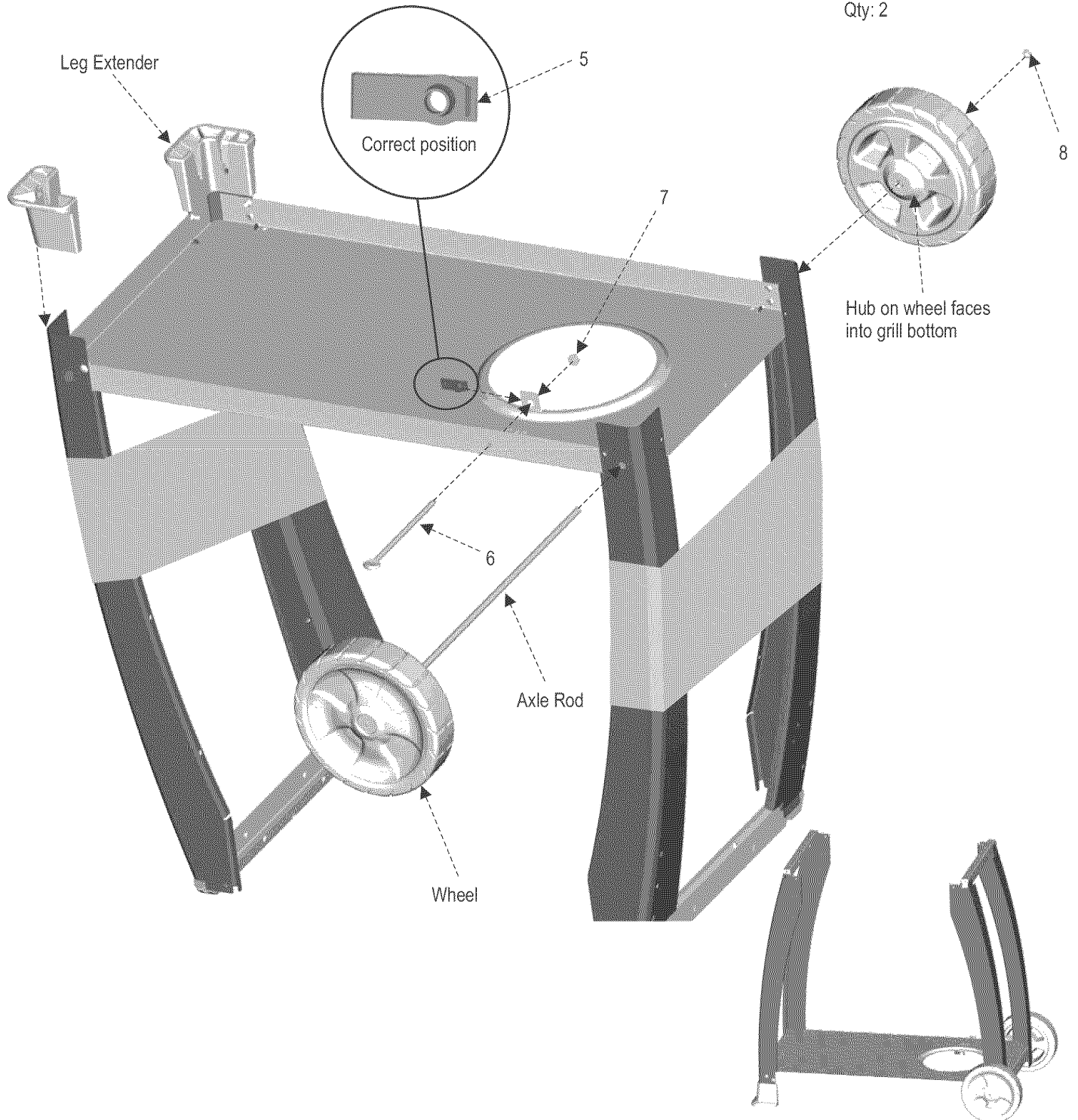
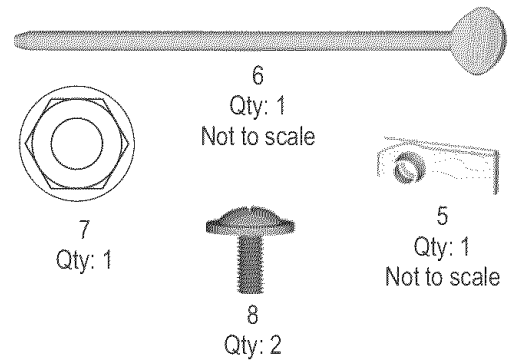

Stand cart upright and remove cardboard sleeves

3

Rail Assembly

- Overlap rails (all identical) and hook tabs into slots. Pull rails to latch.
- Attach rail to legs with two screws in each corner.

HINT:

Firmly push rail down into leg notches. Attach lower screw first.

- Attach one screw in center of each rail.

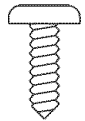

3
Qty:10

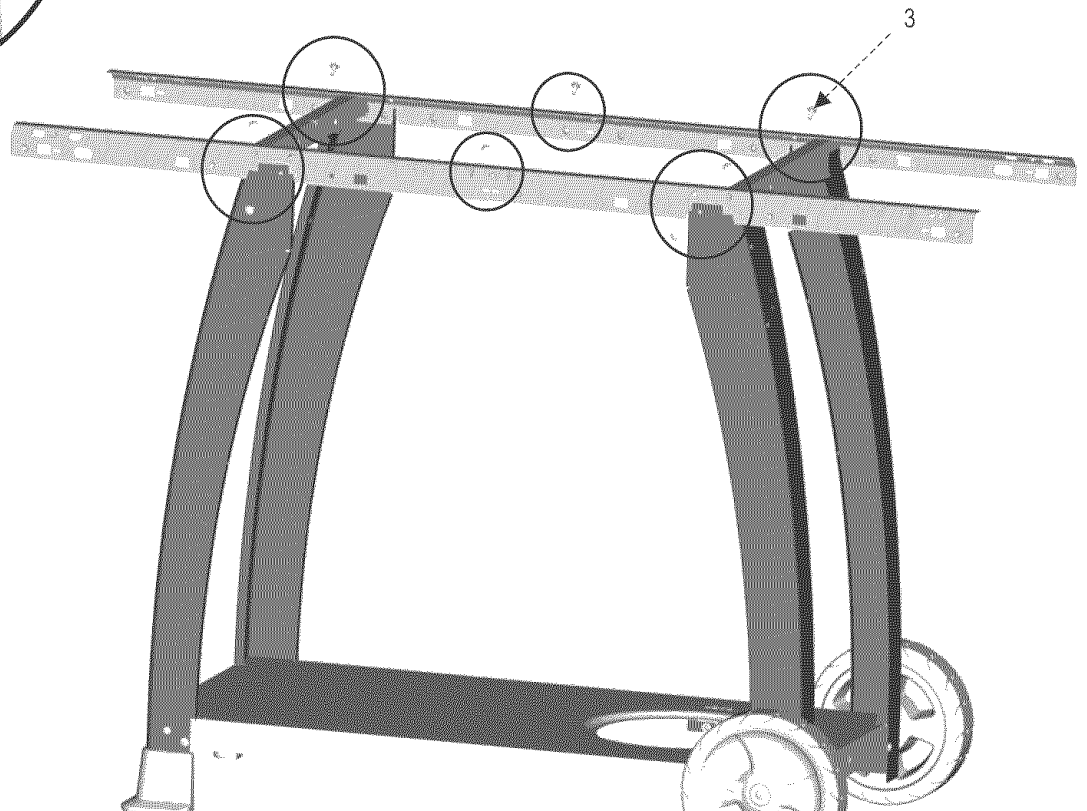
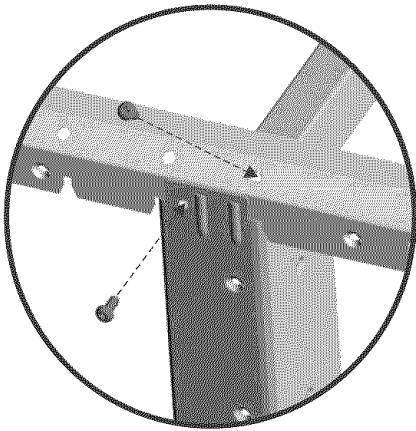
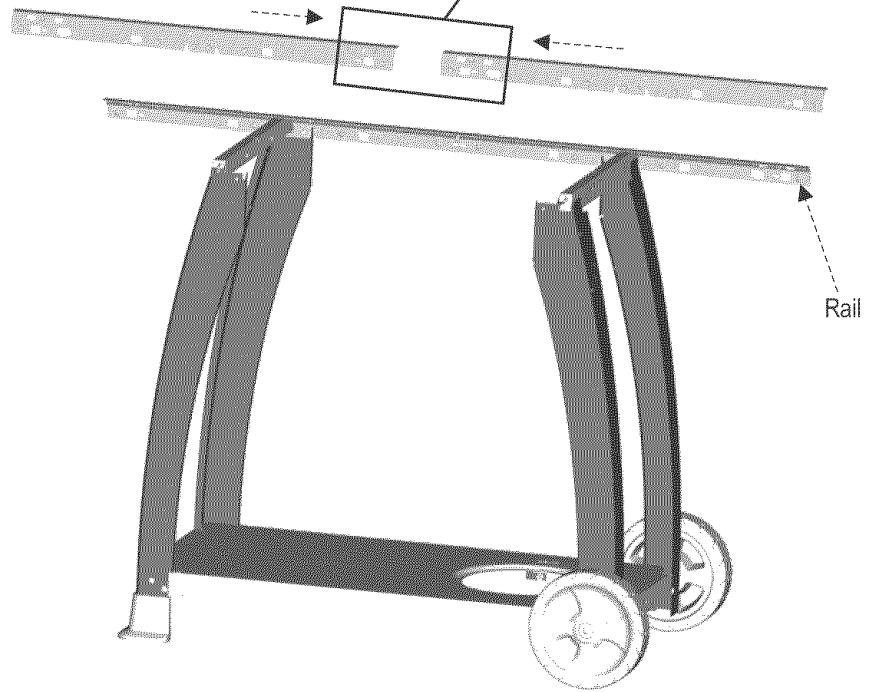
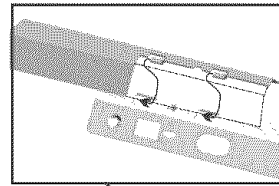

4

Hose Heat Shield

- Attach hose heat shield to right side of cart.

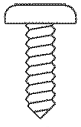

3
Qty: 2

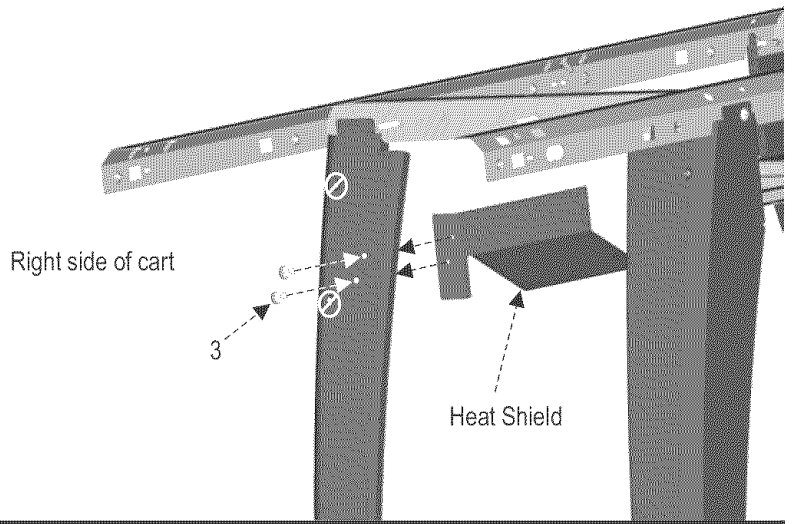

5

Front Panel

- Place push pins halfway into bottom of front panel
- Rotate front panel up, insert push pins.
- Push bottom push pins in all the way.

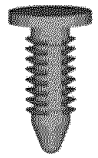

6
Qty: 4

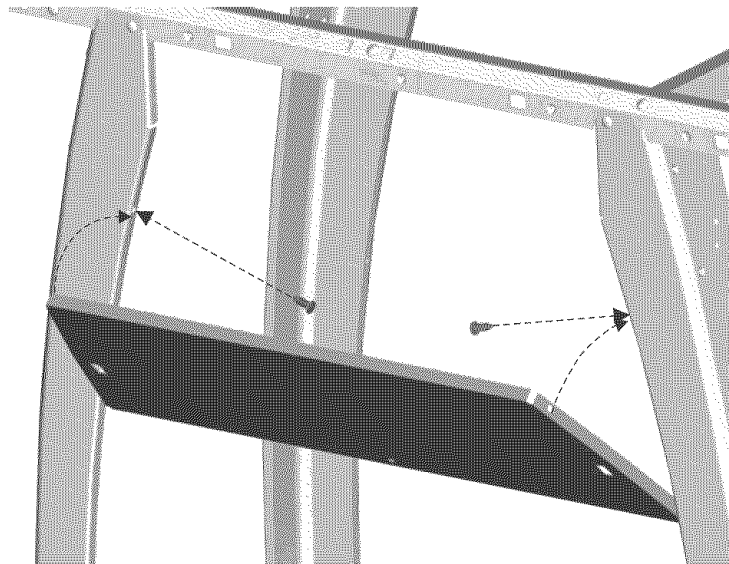
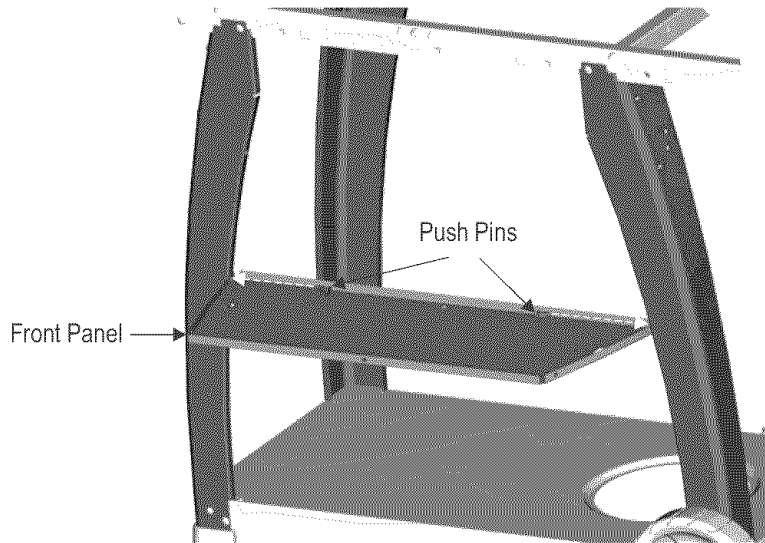

6

Grill Bottom Assembly

- Angle grill bottom assembly around and under the rails.
- Make sure ribs on each side of bottom casting are nestled into notches on casting seat.
- Attach four screws inside grill bottom and into casting seat.

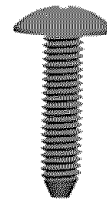

20
Qty: 4

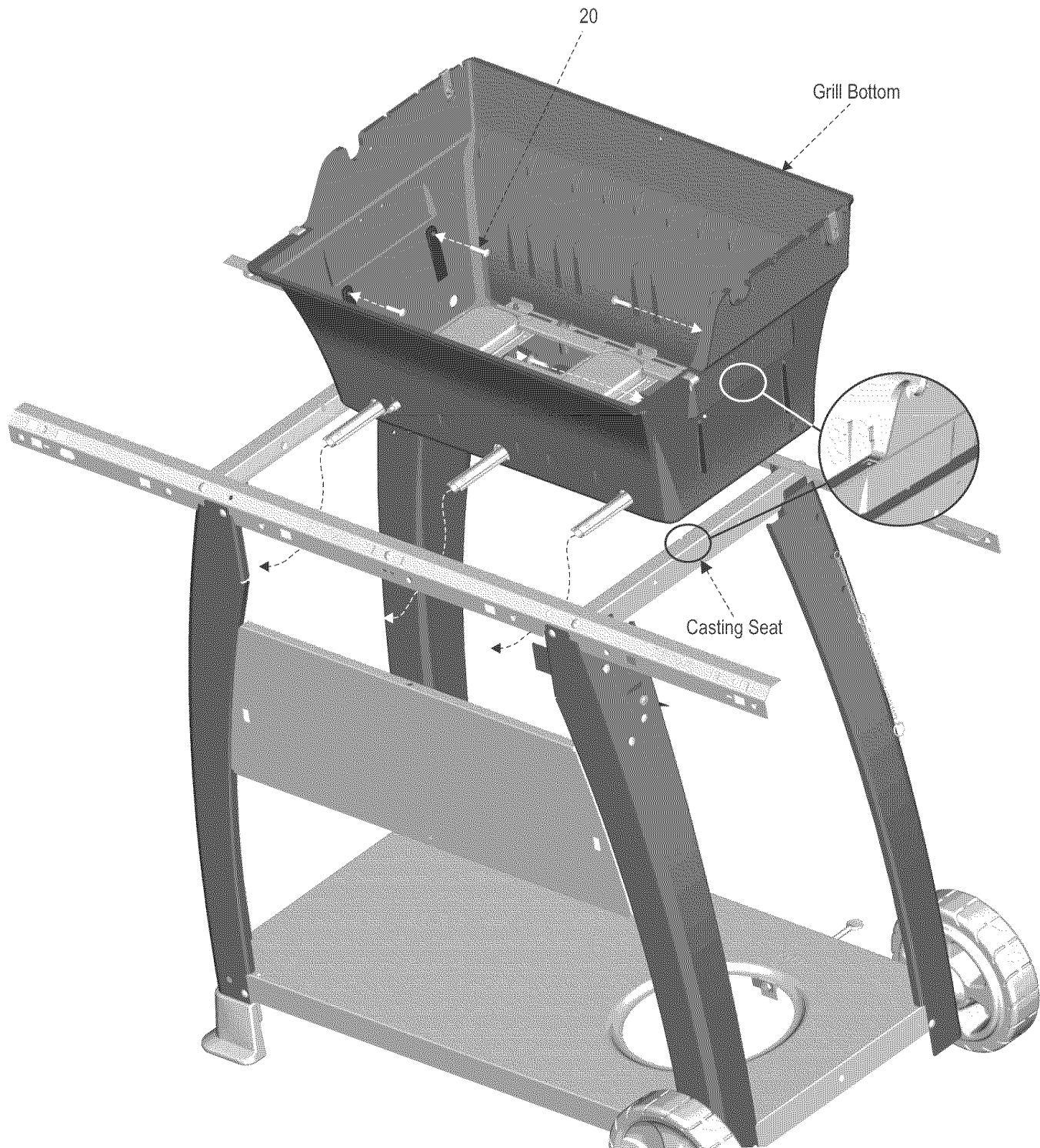

7

Electrode with Wing Nut or Nut

- Inside bottom casting insert electrode and attach with wing nut or nut.

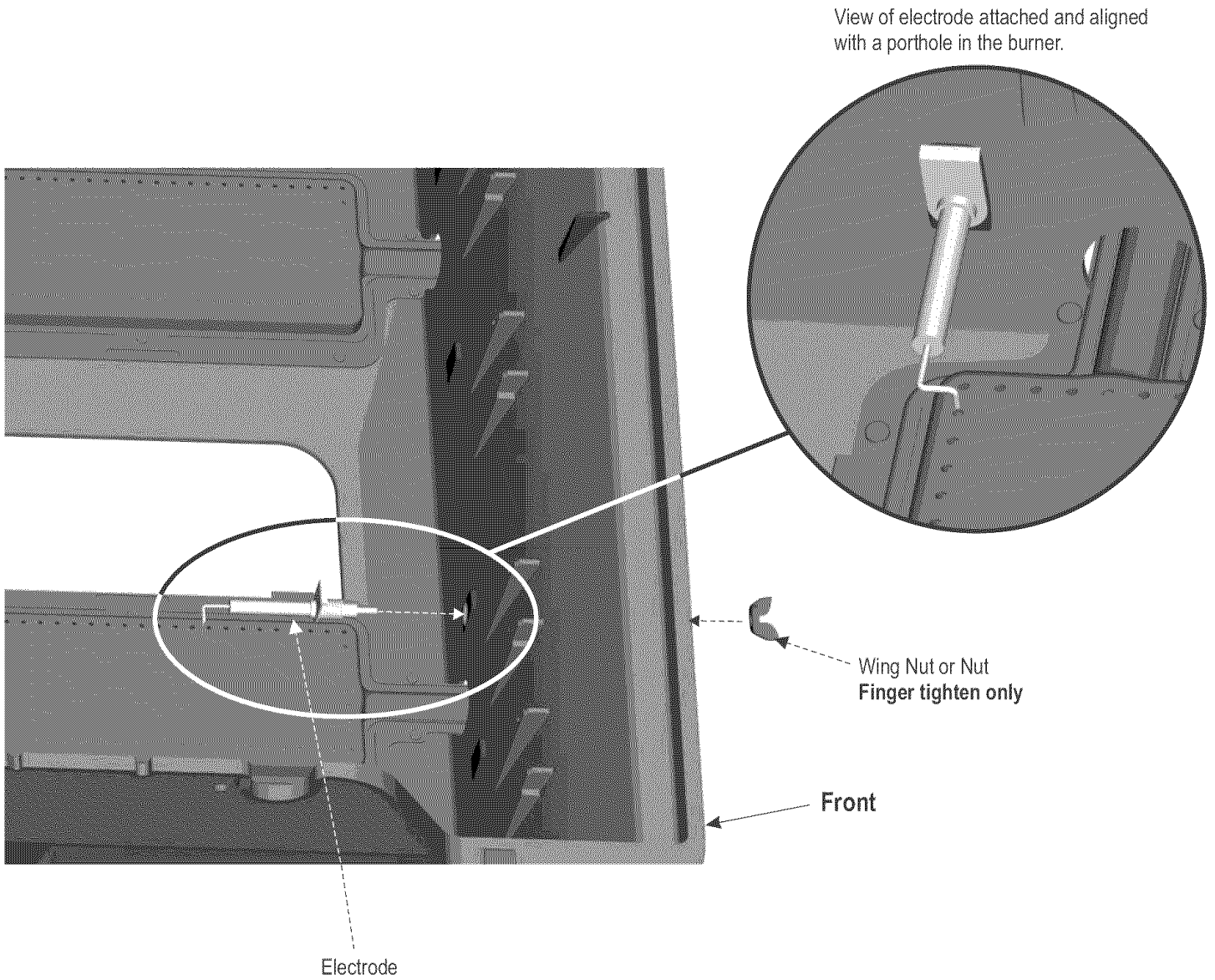

8

Console Assembly

- Hold control panel close to bottom casting. Feed the valve/hose/regulator assembly over the front panel so that it hangs inside the cart.
- Attach ignitor wire to electrode.
- Position valves into burner tubes (see burner-valve view). Rotate control panel up and rest flange over rail.
- Attach control panel to legs with two screws on each side.

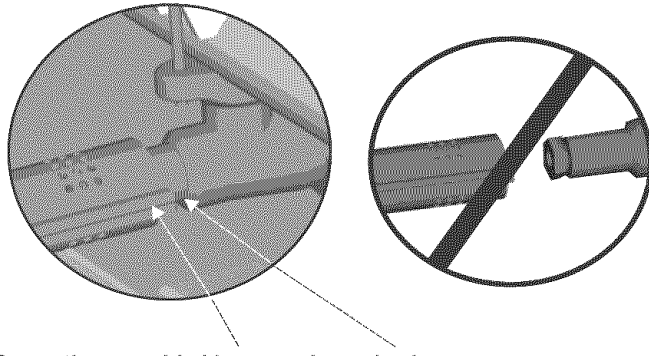
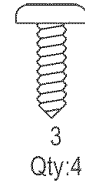

Correctly assembled burner tube and valve.

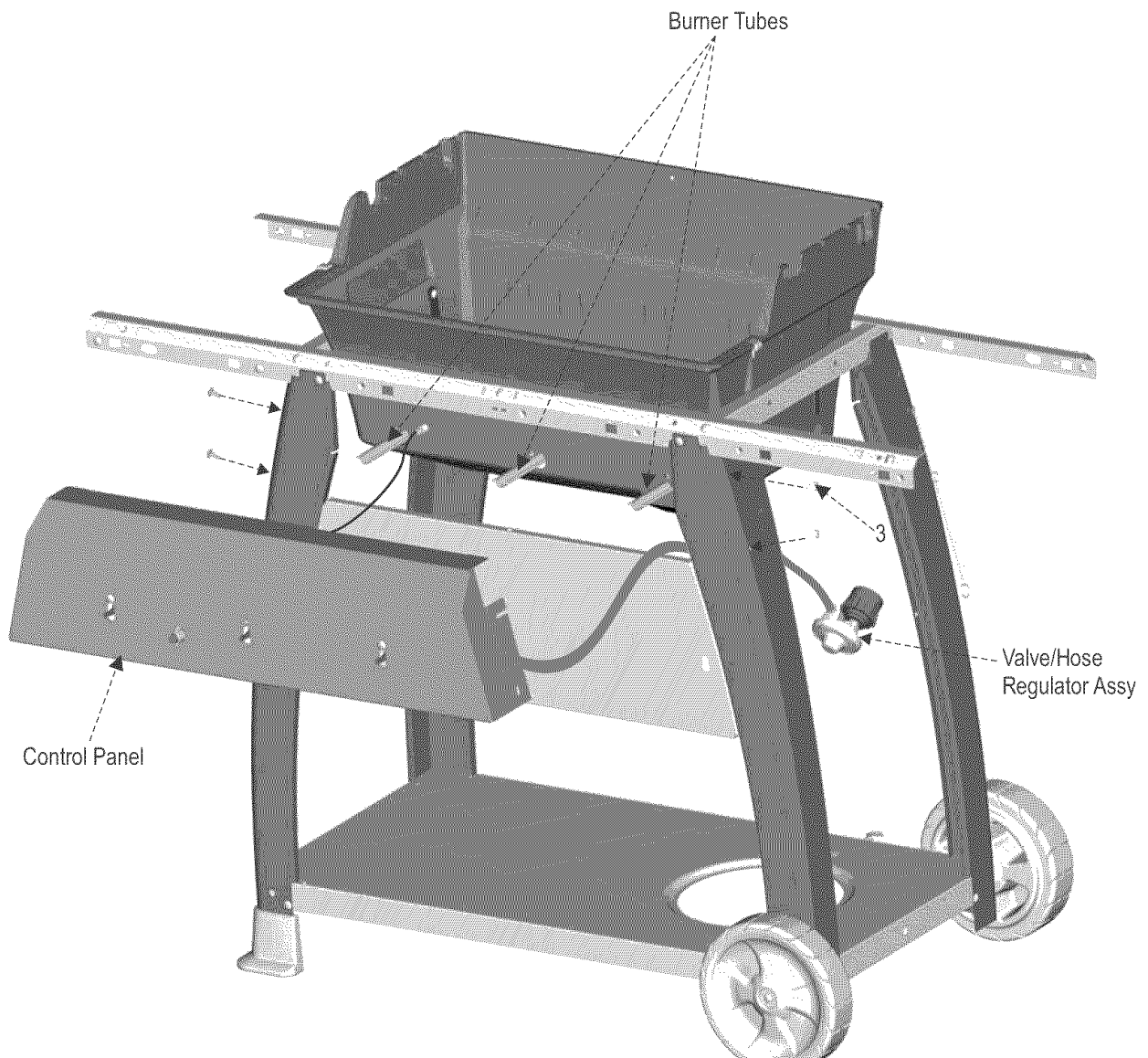

9

Shelves

- Snap shelves into small slots on rail.

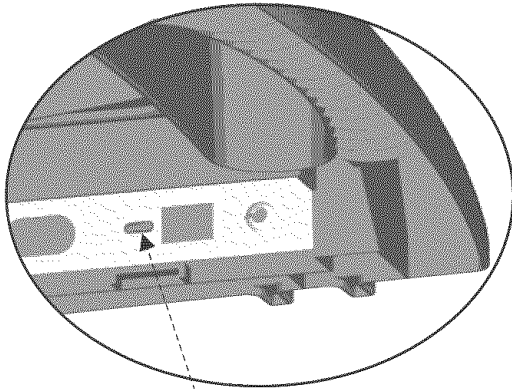

Tab fully secured

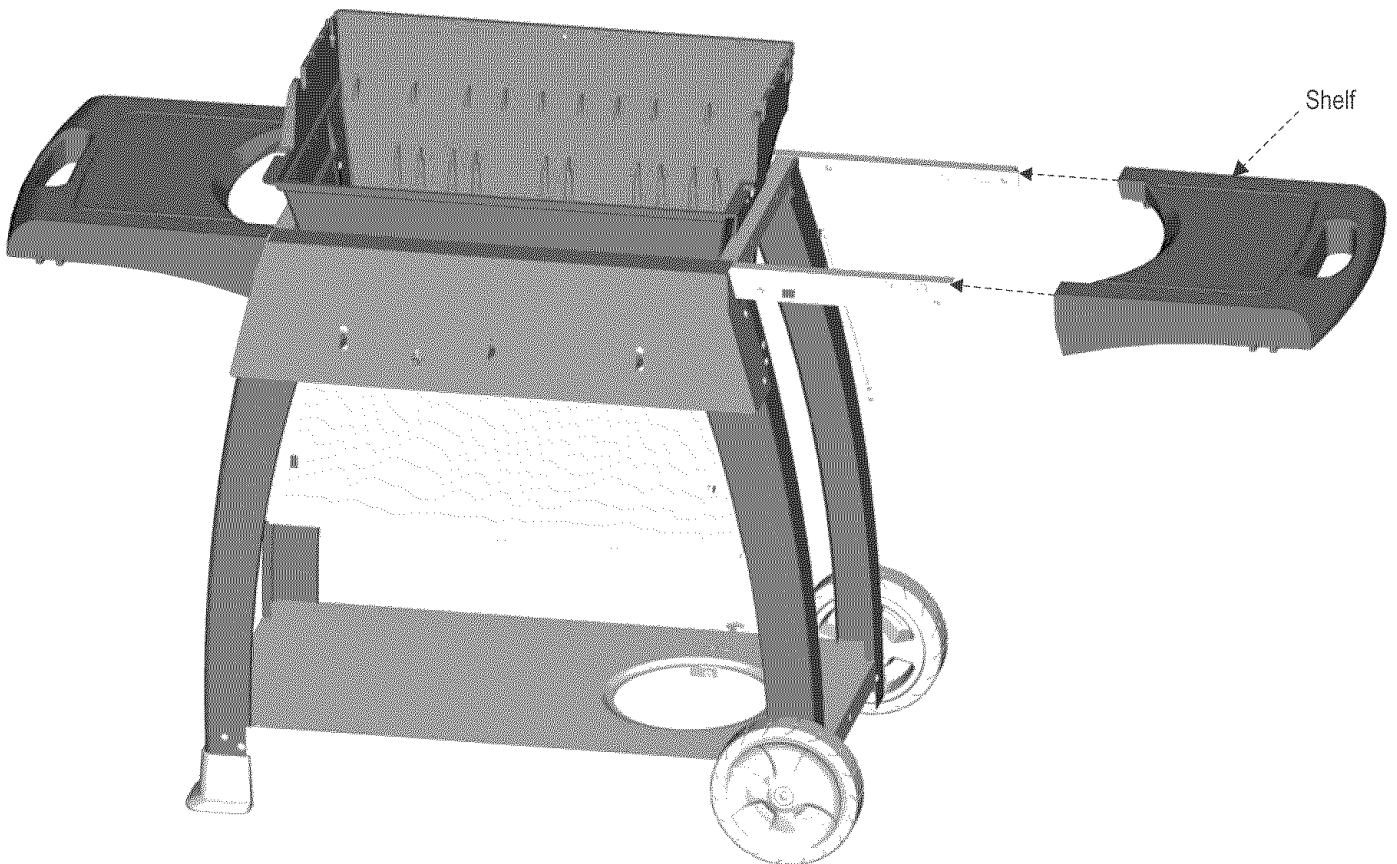
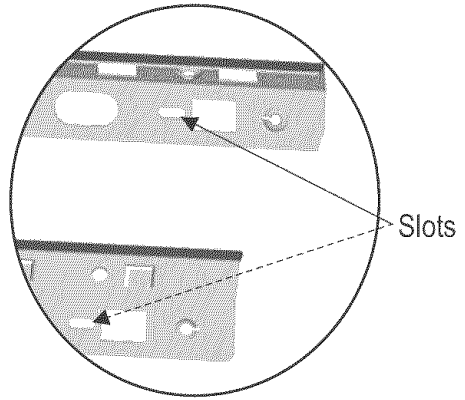

10

Vaporizer Tents, Cooking Grids, Warming Rack, Battery, Ignitor Button, Control Knobs, Top Casting, Handle and Condiment Basket

- Place vaporizer tents directly over burners.
- Place cooking grids onto grid rests.
- Place warming rack onto grill bottom.
- Insert + side of battery into ignitor module. Note correct position to hold ignitor button. Push on button once to engage seal.
- Push control knobs onto valve stems.
- Attach top casting with shoulder bolts.
- Attach handle with wing nuts.
- Insert tabs on condiment basket into holes in front panel. Secure basket to front panel using one push fastener.

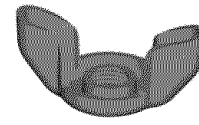

38
Qty. 2

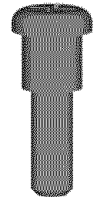

31
Qty. 2

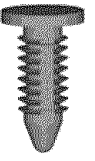

6
Qty: 1

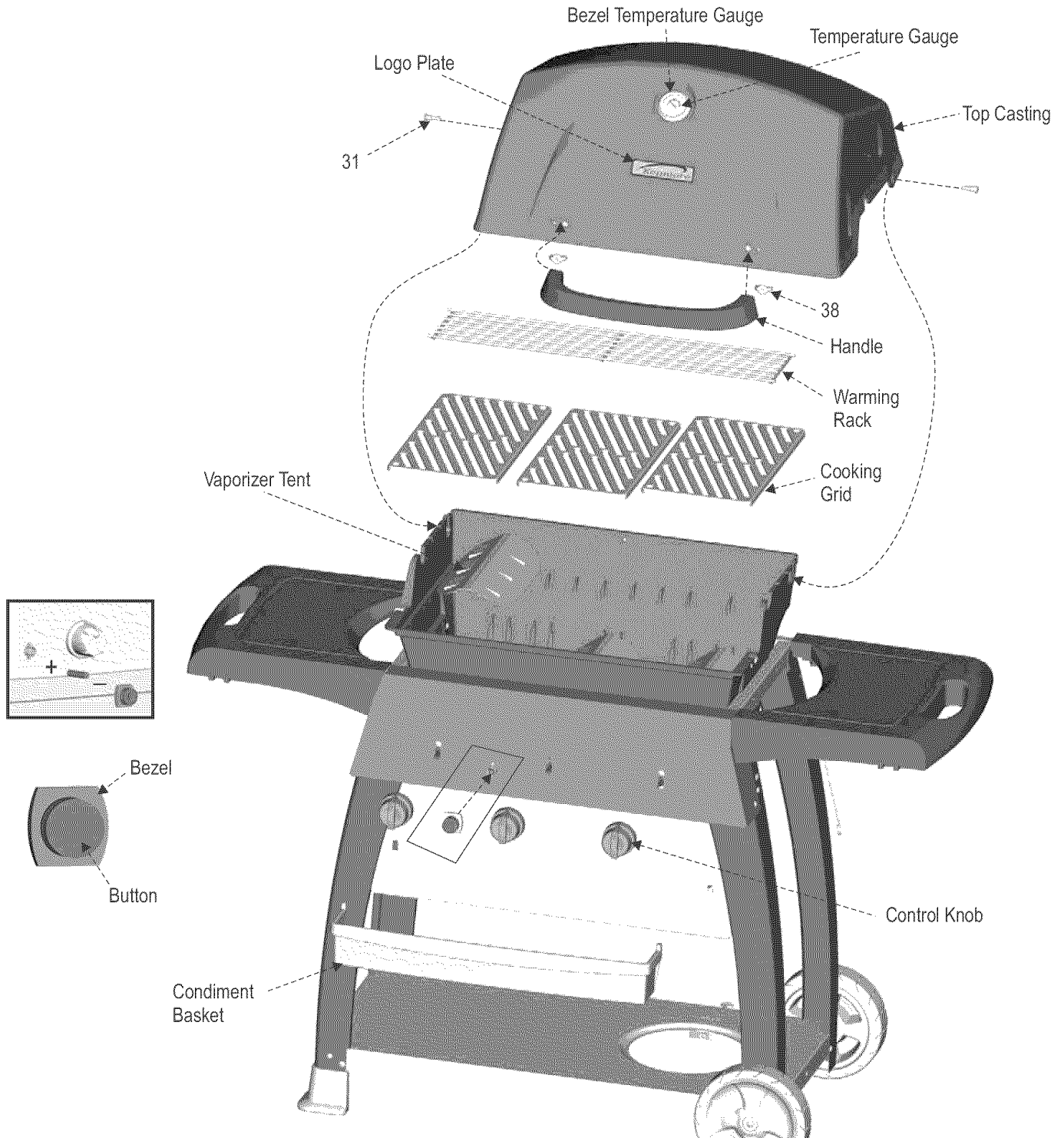

11

LP Tank

- LP tank is sold separately. Use only with an (over-fill protection device) OPD equipped LP tank. Fill and leak check before attaching to grill and regulator.
- Place LP tank into hole in bottom shelf. Finger tighten tank thumbscrew to hold LP tank securely in place.

See Use and Care section to correctly Leak Test and perform the Burner Flame Check.

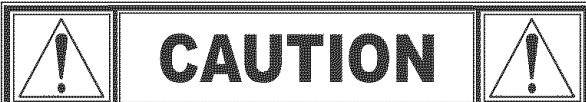
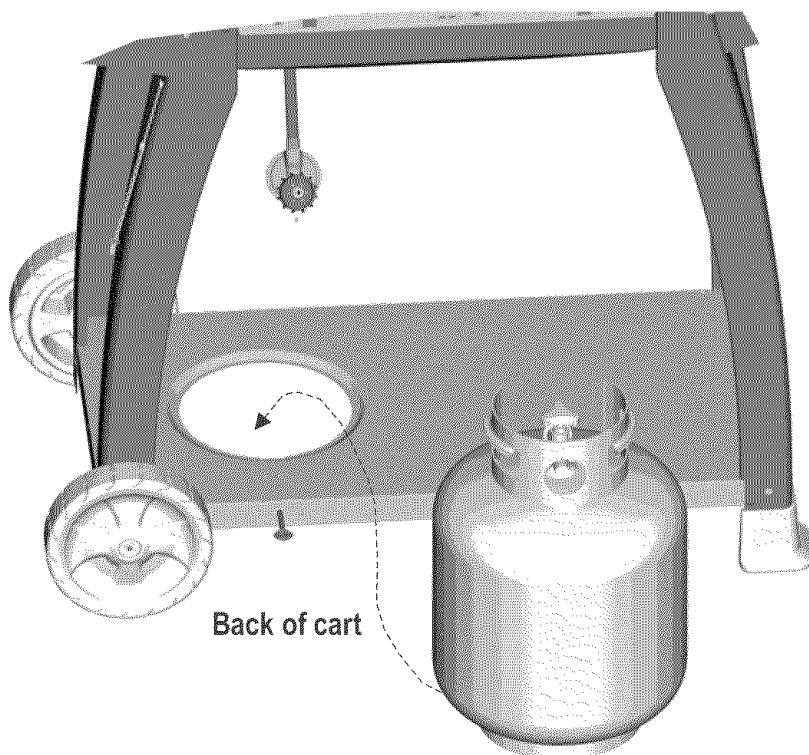

- Tank collar opening must face to front of cart once tank is attached.
- Failure to install tank correctly may allow gas hose to be damaged in operation, resulting in the risk of fire.

12

Grease Tray and Grease Pan

- Slide grease tray onto grill bottom.
- Slide grease pan onto grease tray.



Failure to install the grease tray and grease pan will cause hot grease to drip from bottom of grill with risk of fire or property damage.

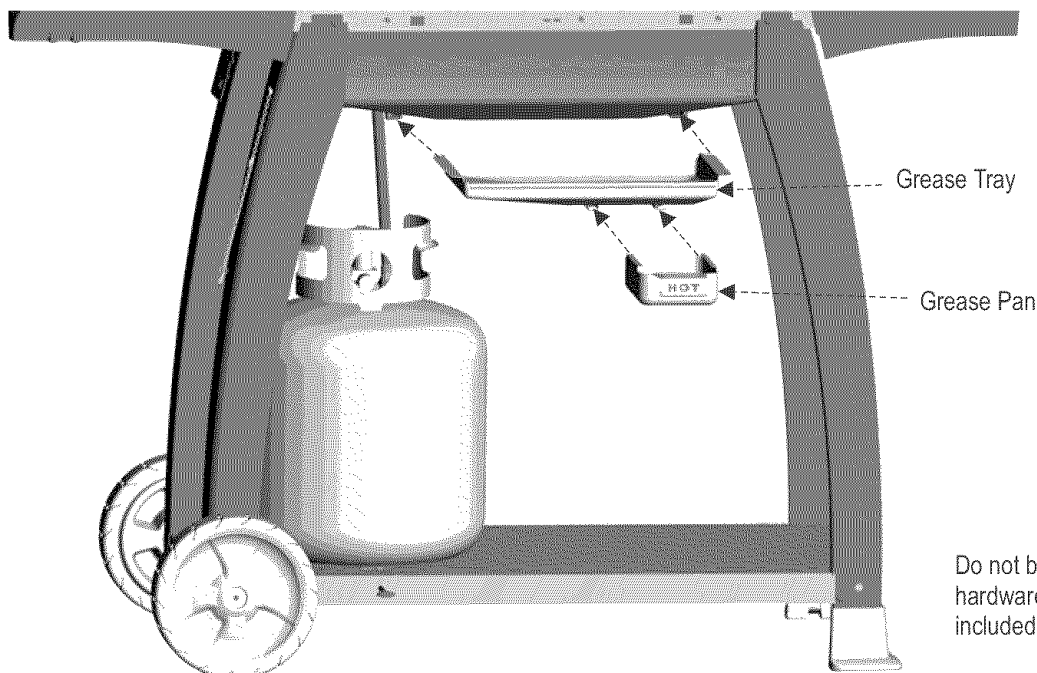

Do not be concerned if you have some hardware left over. Extra hardware has been included to make sure you have enough.

USE AND CARE



DANGER



- Never fill the cylinder beyond 80% full. An overfilled spare LP tank is hazardous due to possible gas released from the safety relief valve.
- When LP tank is over 80% full, the safety relief valve on the LP tank could activate, releasing gas and cause an intense fire with risk of property damage, serious injury or death.
- NEVER store a spare LP tank under or near grill or in enclosed areas.

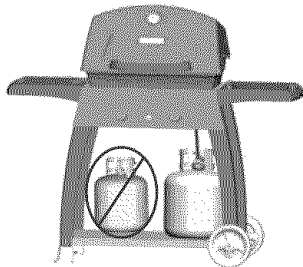

- If you see, smell or hear escaping gas, immediately get away from the LP tank/grill and call your fire department.
- All spare LP tanks must have safety caps installed on the LP tank outlet.

LP Tank

- The LP tank used with your grill must meet the following requirements:
 - Use LP tanks only with these required measurements: 12" (30.5cm) (diameter) x 18" (45.7 cm) (tall) with 20 lb. (9 kg.) capacity maximum.
 - LP tanks must be constructed and marked in accordance with specifications for LP tank of the U.S. Department of Transportation (DOT). See LP tank collar for marking.
 - LP tank valve must have:
 - Type 1 outlet compatible with regulator or grill.
 - Safety relief valve.
 - UL listed Overfill Protection Device (OPD). This OPD safety feature is identified by a unique triangular hand wheel. **Use only LP tanks equipped with this type of valve.**
- LP tank must be arranged for vapor withdrawal and include collar to protect LP tank valve.

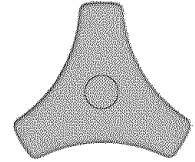

OPD Hand Wheel

LP (Liquefied Petroleum Gas)

- LP gas is nontoxic, odorless and colorless when produced. **For Your Safety**, LP gas has been given an odor (similar to rotten cabbage) so that it can be smelled.
- LP gas is highly flammable and may ignite unexpectedly when mixed with air.

LP Tank Filling

- Use only licensed and experienced dealers.
- LP dealer **must purge tank** before filling.
- Dealer should **NEVER** fill LP tank more than 80% of LP tank volume. Volume of propane in tank will vary by temperature.
- A frosty regulator indicates gas overfill. Immediately close LP tank valve and call local LP gas dealer for assistance.
- Do not release liquid propane (LP) gas into the atmosphere. This is a hazardous practice.
- To remove gas from LP tank, contact an LP dealer or call a local fire department for assistance. Check the telephone directory under "Gas Companies" for nearest certified LP dealers.

LP Tank Removal, Transport And Storage

- Turn OFF all control knobs and LP tank valve. Turn coupling nut counterclockwise by hand only - do not use tools to disconnect. Lift LP tank wire upward off of LP tank collar, then lift LP tank up and off of support bracket. Install safety cap onto LP tank valve. Always use cap and strap supplied with valve. **Failure to use safety cap as directed may result in serious personal injury and/or property damage.**

LP Tank Valve

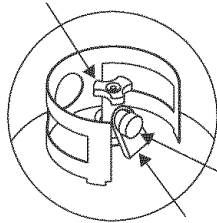

Safety Cap

Retainer Strap

- A disconnected LP tank in storage or being transported must have a safety cap installed (as shown). Do not store an LP tank in enclosed spaces such as a carport, garage, porch, covered patio or other building. Never leave an LP tank inside a vehicle which may become overheated by the sun.
- Do not store an LP tank in an area where children play.



LP Tank Exchange

- Many retailers that sell grills offer you the option of replacing your empty LP tank through an exchange service. Use only those reputable exchange companies that inspect, precision fill, test and certify their cylinders. **Exchange your tank only for an OPD safety feature-equipped tank as described in the "LP Tank" section of this manual.**
- Always keep new and exchanged LP tanks in upright position during use, transit or storage.
- **Leak test new and exchanged LP tanks BEFORE connecting to grill.**

LP Tank Leak Test

For your safety

- Leak test must be repeated each time LP tank is exchanged or refilled.
- Do not smoke during leak test.
- Do not use an open flame to check for gas leaks.
- Grill must be leak tested outdoors in a well-ventilated area, away from ignition sources such as gas fired or electrical appliances. During leak test, keep grill away from open flames or sparks.
- Use a clean paintbrush and a 50/50 mild soap and water solution. Brush soapy solution onto areas indicated by arrows in figure below. Leaks are indicated by growing bubbles.

	WARNING	
<p>If "growing" bubbles appear do not use or move the LP tank. Contact an LP gas supplier or your fire department!</p>		

- ▲ **Do not use household cleaning agents.** Damage to gas train components can result.

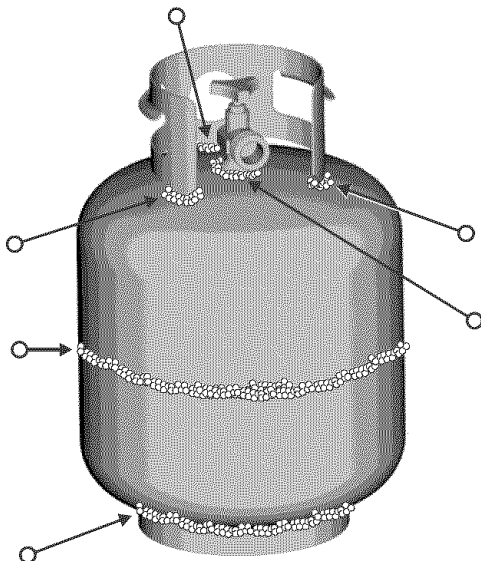

Connecting Regulator To The LP Tank

1. LP tank must be properly secured onto grill. (Refer to assembly section.)
2. Turn all control knobs to the OFF position.
3. Turn LP tank OFF by turning OPD hand wheel clockwise to a full stop.
4. Remove the protective cap from LP tank valve. Always use cap and strap supplied with valve.

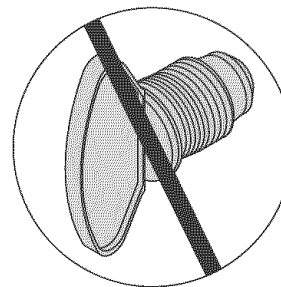
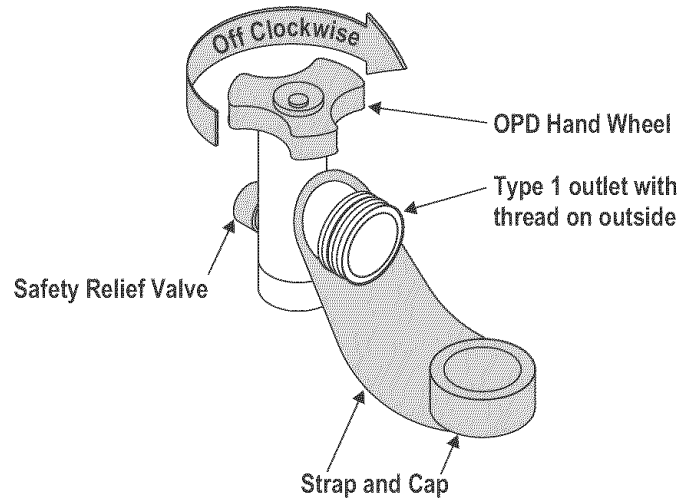

Do not use a POL transport plug (plastic part with external threads)! It will defeat the safety feature of the valve.

5. Hold regulator and insert nipple into LP tank valve. Hand-tighten the coupling nut, holding regulator in a straight line with LP tank valve so as not to cross-thread the connection.

Nipple has to be centered into the LP tank valve.

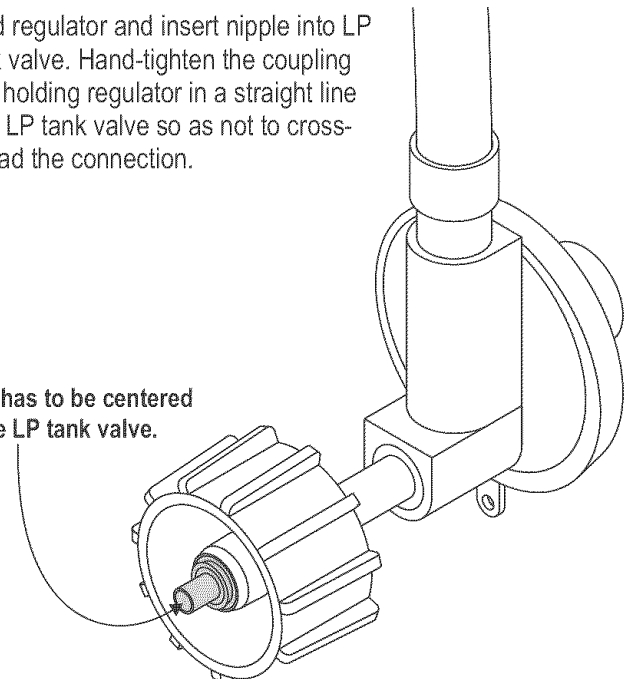

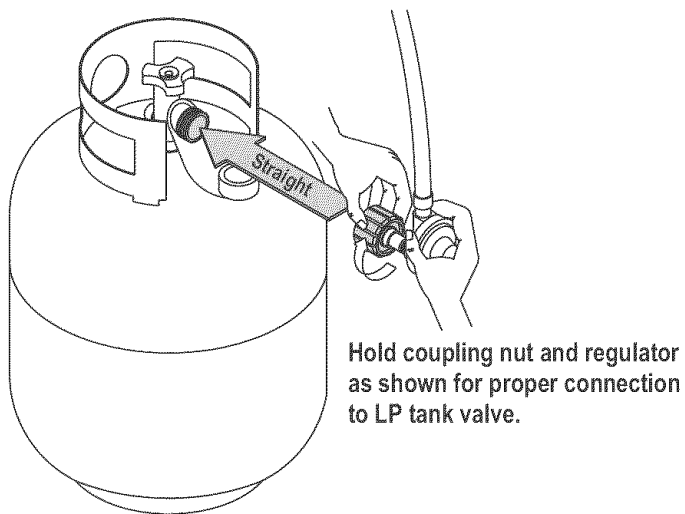

6. Turn the coupling nut clockwise and tighten to a full stop. The regulator will seal on the back-check feature in the LP tank valve, resulting in some resistance. **An additional one-half to three-quarters turn is required to complete the connection. Tighten by hand only – do not use tools.**

NOTE:

If you cannot complete the connection, disconnect regulator and repeat steps 5 and 6. If you are still unable to complete the connection, **do not use this regulator!**

	DANGER	
<ul style="list-style-type: none"> • Do not insert any tool or foreign objects into the valve outlet or safety relief valve. You may damage the valve and cause a leak. Leaking propane may result in explosion, fire, severe personal injury, or death.. • If a leak is detected at any time, STOP and call the fire department. • If you cannot stop a gas leak, <i>immediately</i> close LP tank valve and call LP gas supplier or your fire department! 		

	WARNING	
<ul style="list-style-type: none"> • Never attempt to attach this grill to the self-contained LP gas system of a camper trailer or motor home. • Do not use grill until leak-tested. 		

Leak Testing Valves, Hose and Regulator

1. Turn all grill control knobs to OFF.
2. Be sure regulator is tightly connected to LP tank.
3. Completely open LP tank valve by turning OPD hand wheel counterclockwise. If you hear a *rushing sound*, turn gas off immediately. There is a major leak at the connection. **Correct before proceeding** by calling Sears for replacement parts at 1-800-4-MY-HOME®.
4. Brush soapy solution onto areas where bubbles are shown in picture below:

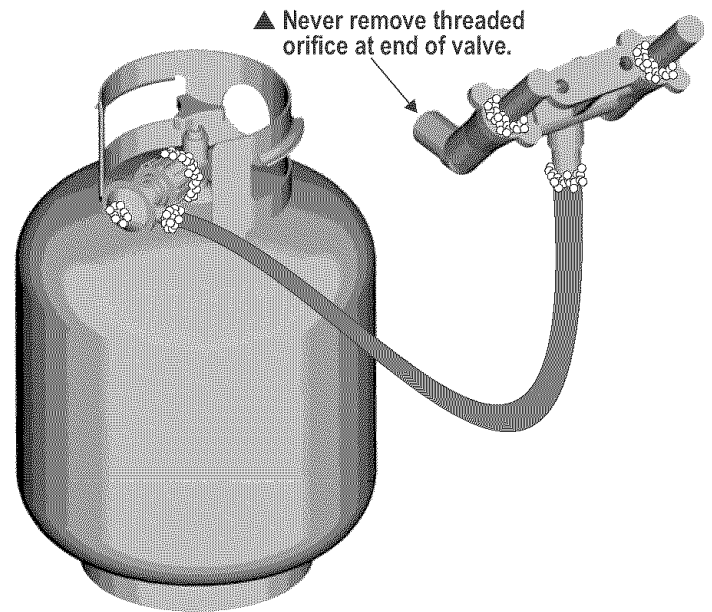

5. If “growing” bubbles appear, there is a leak. Close LP tank valve immediately and retighten connections. **If leaks cannot be stopped do not try to repair.** Call Sears for replacement parts at 1-800-4-MY-HOME®.
6. Always close LP tank valve after performing leak test by turning hand wheel clockwise.



WARNING



For Safe Use Of Your Grill And To Avoid Serious Injury:

- Do not let children operate or play near grill.
- Keep grill area clear and free from materials that burn.
- Do not block holes in bottom or back of grill.
- Check burner flames regularly.
- Use grill only in well-ventilated space. NEVER use in enclosed space such as carport, garage, porch, covered patio, or under an overhead structure of any kind.
- Do not use charcoal or ceramic briquets in a gas grill. *(Unless briquets are supplied with your grill.)*
- **Use grill at least 3 ft. from any wall or surface.** Maintain 10 ft. clearance to objects that can catch fire or sources of ignition such as pilot lights on water heaters, live electrical appliances, etc.

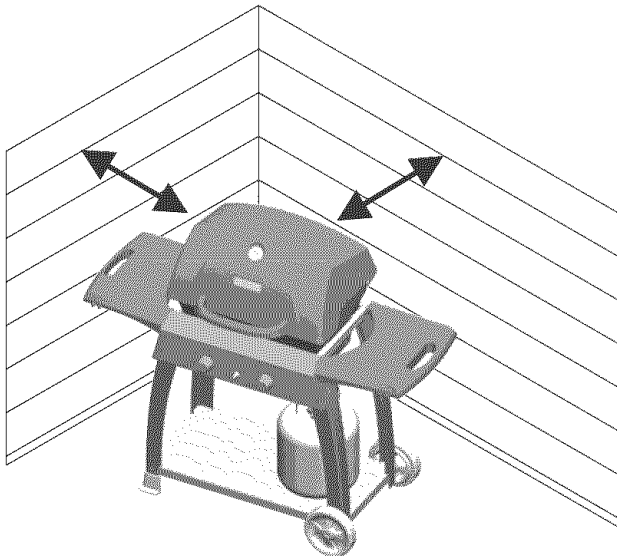

• Apartment Dwellers:

Check with management to learn the requirements and fire codes for using an LP gas grill in your apartment complex. If allowed, use outside on the ground floor with a three (3) foot clearance from walls or rails. Do not use on or under balconies.

- **NEVER attempt to light burner with lid closed.** A buildup of non-ignited gas inside a closed grill is hazardous.
- **Never operate grill with LP tank out of correct position specified in assembly instructions.**
- **Always close LP tank valve and remove coupling nut before moving LP tank from specified operation position.**

Safety Tips

- ▲ Before opening LP tank valve, check the coupling nut for tightness.
- ▲ When grill is not in use, turn off all control knobs and LP tank valve.
- ▲ Never move grill while in operation or still hot.
- ▲ Use long-handled barbecue utensils and oven mitts to avoid burns and splatters.
- ▲ Maximum load for shelves is 10 lbs.
- ▲ The grease cup **must** be attached to grease tray and emptied after each use. Do not remove grease cup until grill has completely cooled.
- ▲ If you notice grease or other hot material dripping from grill onto valve, hose or regulator, turn off gas supply at once. Determine the cause, correct it, then clean and inspect valve, hose and regulator before continuing. Perform a leak test.
- ▲ The regulator may make a humming or whistling noise during operation. This will not affect safety or use of grill.
- ▲ If you have a grill problem see the "Troubleshooting Section".



WARNING

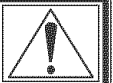

If the regulator frosts, turn off grill and LP tank valve immediately. This indicates a problem with the tank and it should not be used on any product. Return to supplier!

CAUTION

- Putting out grease fires by closing the lid is not possible. Grills are well ventilated for safety reasons.
- Do not use water on a grease fire. Personal injury may result. If a grease fire develops, turn knobs and LP tank off.
- Do not leave grill unattended while preheating or burning off food residue on high. If grill has not been regularly cleaned, a grease fire can occur that may damage the product. Follow instructions on General Grill Cleaning and Cleaning The Burner Assembly to prevent grease fires.

Ignitor Lighting

▲ Do not lean over grill while lighting.

1. Open lid. Turn on gas at LP tank.
2. Turn left knob to 🔥 preheat to light.
3. Push and hold ignitor button to light. Be sure burner lights and stays lit.
4. If burner does not light, turn knobs to OFF, wait 5 minutes, try again.
5. Once left burner is lit, turn right knob to 🔥 preheat to light.
6. If ignitor does not work, wait 5 minutes, then follow match lighting instructions.

After Lighting: Turn knobs to HIGH position for warm-up. Do not warm up grill with knobs in 🔥 preheat position. Knobs and handle will become uncomfortably hot if left in preheat position.

CAUTION

If burner does not light, turn knobs to OFF, wait 5 minutes, and try again. Always close valve during the 5 minute waiting period. If the burner does not ignite with the valve open, gas will continue to flow out of the burner and could accidentally ignite with risk of injury.

Match-Lighting

▲ Do not lean over grill while lighting.

1. Open lid. Turn on gas at LP tank.
2. Place lit match into match lighting hole from outside of grill bottom (as shown).
3. Push in and turn right knob to 🔥 preheat position. Be sure burner lights and stays lit.
4. Light left burner by pushing left knob in and turning to 🔥 preheat position.

After Lighting: Turn knobs to HI for warm-up.

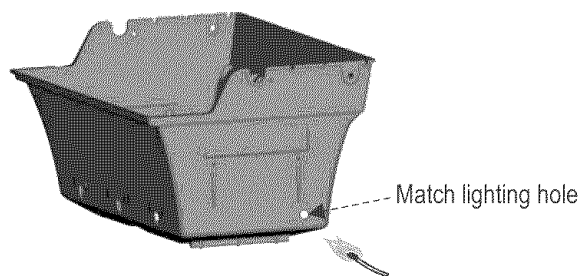

Hose Check

- Before each use, check to see if hoses are cut, worn or kinked. Replace damaged hoses before using grill. Use only valve/hose/regulator specified in the Parts List.

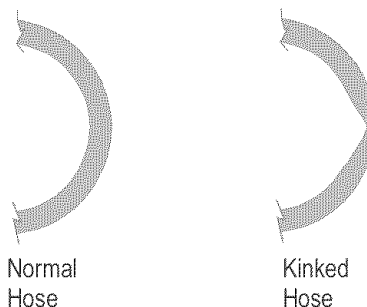

Before Your First Cookout

- Light burners, check to make sure they are lit, close the lid and warm up grill on HIGH for 15 minutes. This curing of paint and parts will produce an odor only on first lighting.

Burner Flame Check

- Light burner, rotate knobs from HI to LO. You should see a smaller flame in LO position than seen on HI. Always check flame prior to each use. If only low flame is seen refer to "Sudden drop or low flame" in the *Troubleshooting Section*.

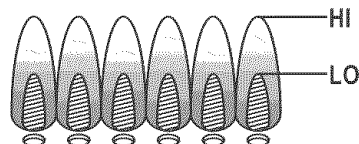

Turning Grill Off

- Turn all knobs to **OFF** position. Turn LP tank off by turning OPD hand wheel clockwise to a full stop.

Ignitor Check

- **Turn gas off at LP tank.** Press and hold ignitor button. "Click" should be heard and spark seen each time between collector box or burner and electrodes. See "*Troubleshooting*" if no click or spark.

Valve Check

- **Important: Make sure gas is off at LP tank before checking valves.** Knobs lock in **OFF** position. To check valves, first push in knobs and release, knobs should spring back. If knobs do not spring back, replace valve assembly before using grill. Turn knobs to **LO** position then turn back to **OFF** position. Valves should turn smoothly.

General Grill Cleaning

- Keep the outside of your grill looking new by cleaning it once a month with warm soap and water or a non-abrasive cleaner. If you don't have a grill cover, wipe off dust and grime before starting your grill.
- Coating the cooking grids with spray-on cooking oil will keep the food from sticking and make clean up easier. After cooking, scrape the grates with a long handled, brass wire bristle brush.
- Check inside the grill bottom for grease build up and clean often, especially after cooking fatty meat.
- Do not mistake brown or black accumulation of grease and smoke for paint. Interiors of gas grills are not painted at the factory (**and should never be painted**). Apply a strong solution of detergent and water or use a grill cleaner with scrub brush on insides of grill lid and bottom. Rinse and allow to completely air dry. **Do not apply a caustic grill/oven cleaner to painted surfaces.**
- **Plated wire grates:** Wash grates and V-bar with concentrated grill cleaner or use soap and water solution. Dry thoroughly and store indoors between cookouts.
- **Plastic parts:** Wash with warm soapy water and wipe dry.
 - ▲ Do not use citrisol, abrasive cleaners, degreasers or a concentrated grill cleaner on plastic parts. Damage to and failure of parts can result.
- **Porcelain grates:** Because of glass-like composition, most residue can be wiped away with baking soda/water solution or specially formulated cleaner. Use non-abrasive scouring powder for stubborn stains.

Repainting Your Grill

- After extended use and exposure to weather, paint on grill may deteriorate or become spotted. Although this detracts from grill's appearance, it will not impair its performance.
- To refinish your grill brush outside of grill lid and bottom with wire brush and lightly sand with fine grit sandpaper. Sanding allows new paint to adhere more easily. Wash grill lid and bottom with soap and water to remove dust and grease. Do not use a grill cleaner on outside of grill. Wipe with vinegar. Refinish outside with heat-resistant paint. **Do not paint inside of grill.**



NATURAL HAZARD • SPIDERS

FACT: Sometimes spiders and other small insects climb into the burner tubes attached to the burners. The spiders spin webs, build nests and lay eggs. The webs or nests can be very small, but they are very strong and can block the flow of gas. Clean burners prior to use after storing, at the beginning of grilling season or after a period of one month not being used.

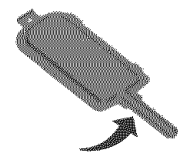
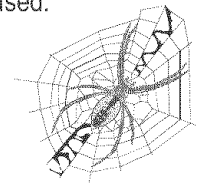

Typical spider webs inside burner.

Spider guards are on the air intakes in an effort to reduce this problem, but it will not eliminate it! An obstruction can result in a "flashback" (a fire in the burner tubes). The grill may still light, but the obstruction does not allow full gas flow to the burners.

IF YOU EXPERIENCE THE FOLLOWING:

1. Smell gas.
2. Burner(s) will not light.
3. A small yellow flame from burner (should be blue).
4. Fire coming from around or behind control knob.

STOP!

Immediately turn off gas at LP tank!

▲ **After a burner tube fire, you must inspect the hose and do a "Leak Test" to assure no damage has occurred to the parts.**

SOLUTION:

Wait for grill to cool.

Follow the "*Cleaning The Burner Assembly*" instructions. Clean burners often. Use a 12" pipe cleaner to clean out the burner tubes. You may also force a stream of water from a hose nozzle through burner tubes to clean them.

Cleaning The Burner Assembly

Follow these instructions to clean and/or replace parts of burner assembly or if you have trouble igniting the grill.

1. **Turn gas off at control knobs and LP tank.**
2. Remove cooking grids and vaporizer tents.
3. Remove two pal nuts, carry-over tube and burners.
4. Under grill remove grease pan and tray. Clean with soap and water.
5. Under console disengage ignitor wire.
6. Wipe ceramic electrode with rubbing alcohol and cloth.
7. Clean carry-over tube and burners exterior with soap and water. Lay burners on flat surface, insert garden hose (preferably with nozzle), into burner tubes forcing water through tubes. Make sure water comes out of every porthole. Open clogged portholes with a thin wire. **Shake out excess water** and examine porthole. Due to normal wear and corrosion some portholes may become enlarged, if so replace burner. If any horizontal cracks appear from porthole to porthole or large holes (other than portholes) are found replace burner.
8. If grill is to be stored, coat burners lightly with cooking oil. Wrap in protective cover to keep insects out. If not storing use following steps.

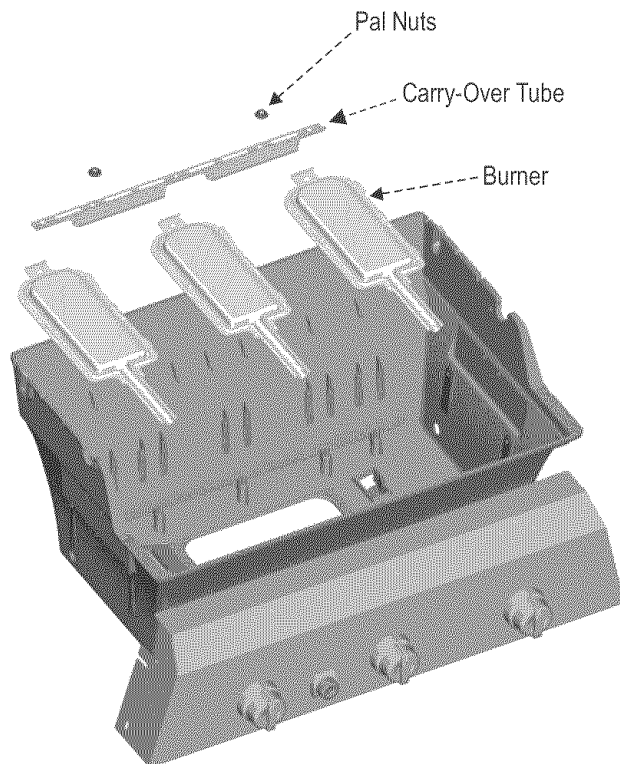

VERY IMPORTANT: Burner tubes must engage valve openings as shown (A).

9. Attach ignitor wire to electrode.
10. Reposition cooking grids and vaporizer tents. Place clean grease tray and pan into grill bottom.
11. Before cooking again on grill, perform a "Leak Test" and "Burner Flame Check".

▲ Do not use ceramic briquets or charcoal in your grill.

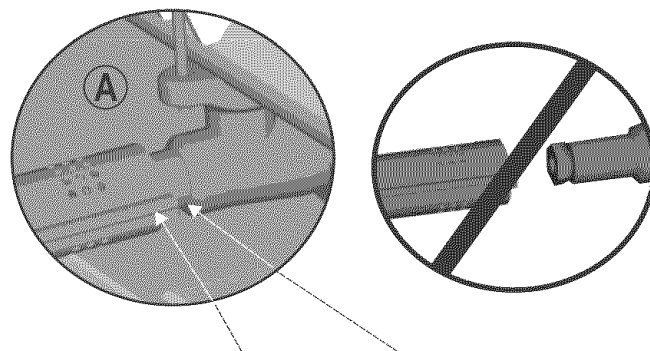

Correctly assembled burner tube and valve.

Cleaning the Grease Tray

Your grill is equipped with a removable grease tray. Although grease will drain from the grease tray to the grease cup provided, food particles and debris may accumulate in the bottom and should be removed after cooking 5 to 10 times. This can easily be done by sliding the grease tray out of the rear of the unit. Make sure in replacing the tray to push it all the way forward.

Storing Your Grill

- Clean cooking grates.
- Store in dry location.
- When LP tank is connected to grill, store outdoors in well-ventilated space and out of reach of children.
- Cover grill if stored outdoors.
- Store grill indoors ONLY if LP tank is turned off and disconnected, removed from grill and stored outdoors.
- When removing grill from storage follow "Cleaning Burner Assembly" instructions before starting grill.

Food Safety

Food safety is a very important part of enjoying the outdoor cooking experience. To keep food safe from harmful bacteria, follow these four basic steps:

Clean: Wash hands, utensils, and surfaces with hot soapy water before and after handling raw meat and poultry.

Separate: Separate raw meats and poultry from ready-to-eat foods to avoid cross contamination. Use a clean platter and utensils when removing cooked foods.

Cook: Cook meat and poultry thoroughly to kill bacteria. Use a thermometer to ensure proper internal food temperatures.

Chill: Refrigerate prepared foods and leftovers promptly.

For more information call: USDA Meat and Poultry Hotline at 1-800-535-4555 in Washington, DC (202) 720-3333, 10:00 am-4:00 pm EST.

How To Tell If Meat Is Grilled Thoroughly

- Meat and poultry cooked on a grill often browns very fast on the outside. Use a meat thermometer to be sure food has reached a safe internal temperature, and cut into food to check for visual signs of doneness.
- Whole poultry should reach 180° F; breasts, 170° F. Juices should run clear and flesh should not be pink.
- Hamburgers made of any ground meat or poultry should reach 160° F, and be brown in the middle with no pink juices. Beef, veal and lamb steaks, roasts and chops can be cooked to 145° F. All cuts of pork should reach 160° F.
- NEVER partially grill meat or poultry and finish cooking later. Cook food completely to destroy harmful bacteria.
- When reheating takeout foods or fully cooked meats like hot dogs, grill to 165° F, or until steaming hot.

Cooking Table

Cooking times and temperatures may vary according to specific recipes, cooking conditions or barbecue equipment used. Take these factors into consideration to insure best results. If you use the indirect cooking method (indirect cooking is lighting only one burner and placing food on opposite side of cooking grate), allow more grilling time.

Temperatures: High = 650°F / Medium = 450°F / Low = 300°F.

Food	Setting	Cooking Time
Beef Hamburger 1/2" thick	Medium	Med: 7-10 min. / Well done: 10-15 min.
Steak 1/2"	Medium-Hot	Rare: 3-6 min. / Med: 6-9 min. / Well done: 9-12 min.
Roast	Low	Rare: 18-22min. per lb. / Med: 22-28 min. per lb. / Well done: 28-32 min. per lb.
Pork Chops 1/2"	Medium	Well done: 15-20 min.
Ribs 5-6 lbs.	Low-Medium	Well done: 45-90 min.
Roast 3-5 lbs.	Low-Medium	Well done: 18-23 min. per lb.
Ham Steak 1/2"	Medium-Hot	12-15 min.
Ham 5 lb. fully cooked	Low-Medium	20 min. per lb.
Lamb Chops 1/2"	Medium	6-12 min.
Poultry Chicken 2-1/2 to 3-1/2 lbs.	Low	1 hr., 15 min. to 1 hr., 30 min.
Chicken halved or quartered	Low	40-60 min.
Turkey	Low-Medium	18-20 min. per lb.
Seafood Steaks 1" thick	Medium-Hot	Well done: 10-25 min.
Filletts 6-8 oz.	Medium-Hot	8-12 min.
Shrimp large or jumbo	Low-Medium	8-12 min.
Venison Steak 1" thick	Medium	Rare: 8-10 min. / Med: 10-12 min.
Burgers 1/2"	Medium	Rare: 10-12 min. / Med: 12-15 min.
Roast 3-4 lbs.	Low-Medium	Rare: 20-22 min. per lb. / Med: 22-25 min. per lb.
Vegetables Baking Potato whole	Low	<i>Wrap vegetables in foil</i> 55-60 min.
Onions whole	Low	45 min.
Tomatoes half	Medium	30-40 min.
Corn whole	Low	35-45 min.
Mushrooms	Medium	15-20 min.

Troubleshooting

Emergencies	Possible Cause	Prevention/Solution
Gas leaking from cracked/cut/burned hose.	<ul style="list-style-type: none"> • Old hose, cut in hose. 	<ul style="list-style-type: none"> • Turn off gas at LP tank. If hose is cut or cracked, replace valve/hose/regulator. If burned, discontinue use of product until a gas service technician/plumber has investigated cause and correction is made.
Gas leaking from LP tank.	<ul style="list-style-type: none"> • Mechanical failure due to rusting or mishandling. 	<ul style="list-style-type: none"> • Turn off LP tank valve.
Gas leaking from LP tank valve.	<ul style="list-style-type: none"> • Failure of tank valve from mishandling or mechanical failure. 	<ul style="list-style-type: none"> • Call LP gas dealer 800-number on tank label or call local fire department.
Gas leaking between LP tank and regulator connection.	<ul style="list-style-type: none"> • Improper installation, connection not tight, failure of rubber seal. 	<ul style="list-style-type: none"> • Remove regulator from tank and visually inspect rubber seal for damage. Reinstall and check for leaks. Ensure black knob is on tight.
Fire coming through control panel.	<ul style="list-style-type: none"> • Fire in burner tube section of burner due to partial blockage. • Misalignment of valve to burner tube. 	<ul style="list-style-type: none"> • Turn off LP tank valve (if possible without injury to self). If fire cannot be controlled with baking soda/extinguisher, call local fire department. Remove burner and inspect for spider nest or rust. Clean using bottle brush. • Ensure valves and burner tubes are aligned per assembly instructions.
Grease fire or continuous excessive flames above cooking surface.	<ul style="list-style-type: none"> • Too much grease buildup in burner area. 	<ul style="list-style-type: none"> • Turn off LP tank valve. Leave lid open to allow flames to die down. After cooling, clean food particles and excess grease from inside firebox area, grease cup/pan/tray, and other surfaces.
Problem	Possible Cause	Prevention/Solution
Burner(s) will not light using ignitor. <i>Continued on next page.</i>	GAS ISSUES: <ul style="list-style-type: none"> • Trying to light wrong burner. • Burner not engaged with control valve. • Obstruction in burner. • No gas flow. • Vapor lock at coupling nut to LP tank. • Coupling nut and LP tank valve not fully connected. 	<ul style="list-style-type: none"> • See instructions on control panel and section in the Use and Care. • Make sure valves are positioned inside of burner tubes. • Ensure burner tubes are not obstructed with spider webs or other matter. See cleaning section of Use and Care. • Make sure LP tank is not empty. If LP tank is not empty, refer to "Sudden drop in gas flow." • Turn off knobs and disconnect coupling nut from LP tank. Reconnect and retry. • Turn the coupling nut approximately one-half to three-quarters additional turn until solid stop. Tighten by hand only - do not use tools.
	ELECTRICAL ISSUES: <ul style="list-style-type: none"> • Electrode cracked or broken; "sparks at crack." • Electrode tip not in proper position. • Wire and/or electrode covered with cooking residue. • Wires are loose or disconnected. • Wires are shorting (sparking) between ignitor and electrode. 	<ul style="list-style-type: none"> • Replace electrode. • Tip of electrode should be pointing toward port hole in burner. The distance should be 1/8" to 3/16". Adjust if necessary. • Clean wire and/or electrode with rubbing alcohol and clean swab. • Reconnect wires or replace electrode/wire assembly. • Replace ignitor wire.

Troubleshooting (continued)

Problem	Possible Cause	Prevention/Solution
Burner(s) will not light using ignitor.	<ul style="list-style-type: none"> • Push-button sticks at bottom.. • Sparking between ignitor and electrode. 	<ul style="list-style-type: none"> • Replace ignitor. • Inspect wire insulation and proper connection. Replace wires if insulation is broken.
Burner(s) will not match light.	<ul style="list-style-type: none"> • See “GAS ISSUES:” on previous page. • Improper method of match-lighting. 	<ul style="list-style-type: none"> • See “Match-Lighting” section of Use and Care.
Sudden drop in gas flow or low flame.	<ul style="list-style-type: none"> • Out of gas. • Excess flow valve tripped. • Vapor lock at coupling nut/LP tank connection. 	<ul style="list-style-type: none"> • Check for gas in LP tank. • Turn off knobs, wait 30 seconds and light grill. If flames are still low, turn off knobs and LP tank valve. Disconnect regulator. Reconnect regulator and leak-test. Turn on LP tank valve, wait 30 seconds and then light grill. • Turn off knobs and LP tank valve. Disconnect coupling nut from tank. Reconnect and retry.
Flames blow out.	<ul style="list-style-type: none"> • High or gusting winds. • Low on LP gas. • Excess flow valve tripped. 	<ul style="list-style-type: none"> • Turn front of grill to face wind or increase flame height. • Refill LP tank. • Refer to “Sudden drop in gas flow” above.
Flare-up.	<ul style="list-style-type: none"> • Grease buildup. • Excessive fat in meat. • Excessive cooking temperature. 	<ul style="list-style-type: none"> • Clean burners and inside of grill/firebox. • Trim fat from meat before grilling. • Adjust (lower) temperature accordingly.
Persistent grease fire.	<ul style="list-style-type: none"> • Grease trapped by food buildup around burner system. 	<ul style="list-style-type: none"> • Turn knobs to OFF. Turn gas off at LP tank. Leave lid in position and let fire burn out. After grill cools, remove and clean all parts.
Flashback... (fire in burner tube(s)).	<ul style="list-style-type: none"> • Burner and/or burner tubes are blocked. 	<ul style="list-style-type: none"> • Turn knobs to OFF. Clean burner and/or burner tubes. See burner cleaning section of Use and Care manual.
Unable to fill LP tank.	<ul style="list-style-type: none"> • Some dealers have older fill nozzles with worn threads. 	<ul style="list-style-type: none"> • The worn nozzles don't have enough “bite” to engage the valve. Try a second LP dealer.
One burner does not light from other burner(s).	<ul style="list-style-type: none"> • Grease buildup or food particles in end(s) of carryover tube(s). 	<ul style="list-style-type: none"> • Clean carry-over tube(s) with wire brush.

Troubleshooting - Electronic Ignition

Problem (Ignition)	Possible Cause	Check Procedure	Prevention/Solution
<p>SECTION I No sparks appear at any electrodes when ignition button is pushed; no noise can be heard from spark module.</p>	<ul style="list-style-type: none"> • Battery not installed properly. • Dead battery. • Button assembly not installed properly. • Faulty spark module. 	<ul style="list-style-type: none"> • Check battery orientation. • Has battery been used previously? • Check to ensure button assembly is fully engaged. Button should travel up and down without binding. • If no sparks are generated with new battery and good wire connections, module is faulty. 	<ul style="list-style-type: none"> • Install battery (make sure that “-” and “+” connectors are oriented correctly, with “-” end up and “+” end down.) • Replace battery with new AAA-size alkaline battery. • Remove button cap assembly and reinstall, making sure it can be fully engaged. • Replace spark module assembly.
<p>SECTION II No sparks appear at any electrodes when ignition switch is pushed; noise can be heard from spark module.</p>	<ul style="list-style-type: none"> • Output lead connections not connected. • Electrode tip not in proper position. 	<ul style="list-style-type: none"> • Are output connections on and tight? • Are the electrode tips pointing in the right direction? Is the gap too big? 	<ul style="list-style-type: none"> • Remove and reconnect all output connections at module and electrodes. <p>Main Burners:</p> <ul style="list-style-type: none"> • Tip of electrode should be pointing toward port hole in burner. The distance should be 1/8” to 3/16”. Adjust if necessary.
<p>SECTION III Sparks are present but not at all electrodes and/or not at full strength</p>	<ul style="list-style-type: none"> • Output lead connections not connected. • Arcing to grill away from burner(s). • Weak battery. • Electrodes are wet. • Electrodes cracked or broken “sparks at crack”. 	<ul style="list-style-type: none"> • Are output connections on and tight? • If possible, observe grill in dark location. Operate ignition system and look for arcing between output wires and grill frame. • All sparks present but weak or at slow rate. • Has moisture accumulated on electrode and/or in burner ports? • Inspect electrodes for cracks. 	<ul style="list-style-type: none"> • Remove and reconnect all output connections at module and electrodes. • If sparks are observed other than from burner(s), wire insulation may be damaged. Replace wires. • Replace battery with a new AAA-size alkaline battery. • Use paper towel to remove moisture. • Replace cracked or broken electrodes.

Please register your grill online at:
Sirvase registrar su parrilla en línea, en:

WWW.GRILLREGISTRATION.COM

(If you register online, you do not need to send in this registration card./Si la registra en línea, no es necesario que envíe esta tarjeta de registro.)

PLEASE FILL OUT THIS CARD AND RETURN IT *WITHIN 10 DAYS OF PURCHASE. FAILURE TO RETURN MAY AFFECT YOUR WARRANTY COVERAGE.*
LLENE ESTA TARJETA Y DEVUÉLVALA DENTRO DE LOS 10 DÍAS DE LA COMPRA. *SI NO LA DEVUELVE, PUEDE VERSE AFECTADA SU COBERTURA DE GARANTÍA.*
VEUILLEZ COMPLÉTER CETTE CARTE ET LA RETOURNER DANS LES 10 JOURS SUIVANT L'ACHAT.
LA COUVERTURE DE VOTRE GARANTIE POURRAIT EN ÊTRE AFFECTÉE SI VOUS NE LE FAITES PAS.

1 First Name/Nombre/Prénom _____ Initial/Inicial/Initiale _____ Last Name/Apellido/Nom de famille _____
Address (number and street)/Dirección (número y calle)/Adresse (numéro et rue) _____ Apt Number/Nº de apart./Nº d'appt. _____
City/Ciudad/Ville _____ State/Estado/Province _____ Zip Code/Código zip/Code postal _____

2 E-mail Address/Dirección de correo electrónico/Adresse électronique _____
If you voluntarily provide us with your email address, you give us permission to use your email address to send you offers that may interest you.
Si nos informa voluntariamente su dirección de correo electrónico, nos da permiso para usarlo a fin de enviarle ofertas que pueden interesarle.
Si vous choisissez de nous fournir votre adresse électronique, vous nous donnez la permission de l'utiliser pour vous faire part d'offres spéciales susceptibles de vous intéresser.

(Example: your name@your host.com) (Ejemplo: su nombre@su host.com) (Exemple : votre nom@votre hôte.com)

3 Phone Number/Número telefónico/Numéro de téléphone _____

6 Date of Purchase/Fecha de compra/Date de l'achat _____

4 **IMPORTANT! / IMPORTANTE! / IMPORTANT!**
Write Serial Number and Model Number in spaces below.
Escriba en los espacios de abajo el número de serie y el número de modelo.
Inscrivez le numéro de série et le numéro de modèle dans les espaces ci-dessous.

7 Store Name/Nombre de la tienda/Nom du magasin _____

8 Purchase Price/Precio de compra/Prix d'achat
\$ _____ .00

5 Your Gender/Su sexo/Sexe: 1. Male/Masculino/Masculin 2. Female/Femenino/Féminin

9 Which product are your registering?
¿Qué producto está registrando?
Quel produit enregistrez-vous?
1. Gas Grill/Parrilla de gas/
Gril au gaz
2. Electric Grill/Parrilla eléctrica/
Gril électrique
3. Smoker/Ahumadora/Fumoir
4. Charcoal Grill/Parrilla de carbón/
Barbecue au charbon
5. Charcoal Smoker/Ahumadora de
carbón/Fumoir au charbon
6. Outdoor Fireplace/Hogar para
exteriores/Foyer extérieur
7. Cooker/Fryer / Cocina/freidora /
Cuisneur/Friteuse
8. Other/Otro/Autre

10 Which of these sources influenced your decision to buy this product? (check all that apply)
¿Cuál de estas fuentes influyó a su decisión de comprar este producto? (Marque todas las que correspondan)
Parmi les éléments ci-dessous, qu'est-ce qui a influencé votre décision d'acheter ce produit?
(Cochez tous les éléments s'appliquant)
1. Magazine/newspaper advertisement / Propaganda en revista/periódico /
Publicité dans un magazine ou dans un journal
2. Television commercial/Comercial televisivo/Publicité à la télévision
3. Grill was assembled/Parrilla ensamblada/Le gril était déjà assemblé
4. In-store display/Exhibidor en la tienda/Promotion sur le lieu de vente
5. Store circular/Circular de la tienda/Prospectus de magasin
6. Brand name/Marca/Marque
7. Product style/Estilo del producto/Style du produit
8. Price/value / Precio/valor / Rapport prix/valeur
9. Product quality/Calidad del producto/Qualité du produit
10. Friend/Relative recommendation / Recomendación de amigo o pariente /
Recommandation d'un(e) ami(e)/parent(e)
11. Salesperson recommendation/Recomendación del vendedor/
Recommandation d'un(e) préposé(e) à la vente
12. Grill size/Tamaño de la parrilla/Taille du gril
13. Product warranty/Garantía del producto/Garantie du produit
14. Store demonstration/Demostración en la tienda/Démonstration en magasin
15. Point of purchase/Punto de compra/Lieu de vente
16. Other/Otras/Autre: _____

Mail to:
Product Registration Dept.
PO BOX 1240
Columbus, Georgia 31902-1240

Thank you for completing this questionnaire. Your answers will help us and other companies reach you with offers that may interest you. If you prefer not to receive these offers, please check here .

Gracias por completar este cuestionario. Sus respuestas nos ayudarán, a nosotros y a otras compañías, a llegar a ustedes con ofertas que puedan resultarles de interés. Si prefiere no recibir estas ofertas, por favor marque aquí .

Merci d'avoir bien voulu remplir ce questionnaire. Vos réponses nous aideront et aideront d'autres compagnies à vous communiquer des offres spéciales susceptibles de vous intéresser. Si vous préférez ne pas recevoir d'informations concernant ces offres spéciales, veuillez cocher ici .