

Owner's Manual



Liquid Propane Gas Grill

Model 141.157941

Natural Gas Grill

Model 141.157951

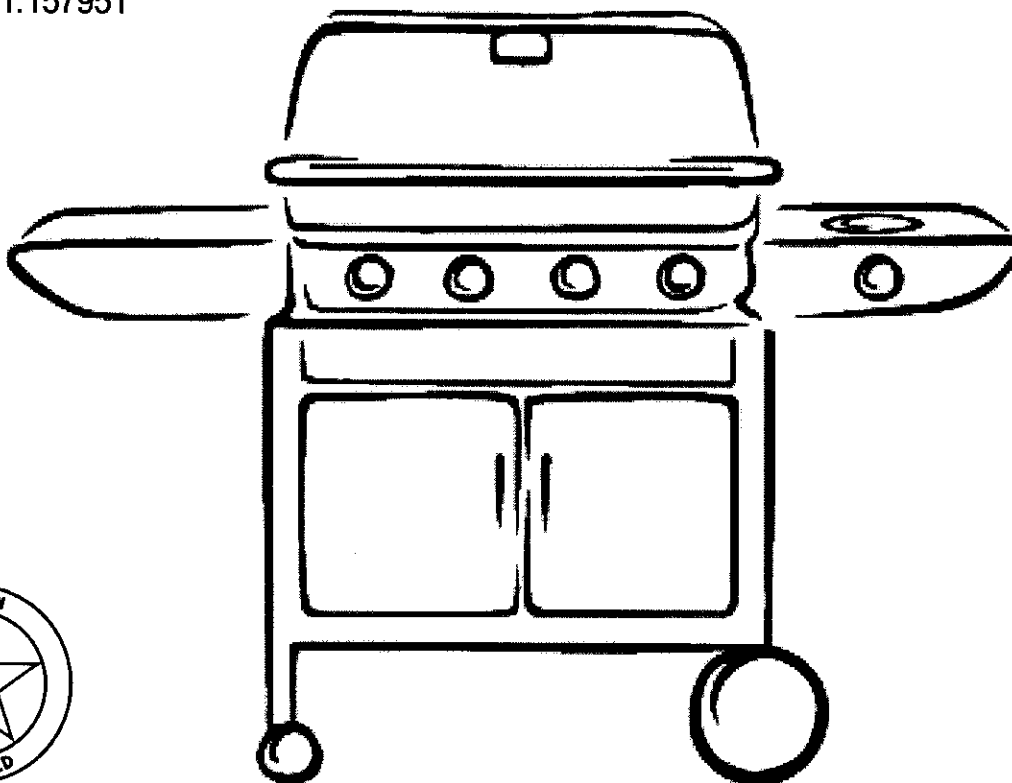

WARNING:

Read this Owner's Manual carefully and be sure your gas grill is properly assembled, installed and maintained. Failure to follow these instructions could result in serious bodily injury and/or property damage. This gas grill is intended for outdoor use only and is not intended to be installed in or on recreational vehicles or boats.

Note to Installer:

Leave this Owner's Manual with the consumer after delivery and/or installation.

Note to Consumer:

Leave this Owner's Manual in a convenient place for future reference.

Manufacturer Customer Service Helpline:

If the shipping box is missing parts or you have questions about assembly, call the Customer Service Helpline 8am - 11pm CST, Monday through Friday at 1-888-317-7642.

**Sears, Roebuck and Co.,
Hoffman Estates, IL 60179 U.S.A.**

Table of Contents

Warranty	2
Safety Instructions	2
Pre-Assembly Instructions	4
Parts Diagram and Part Lists	5
Assembly Instructions	8
Lighting Instructions	14
Cooking Instructions	16
Cleaning and Maintenance Instructions	16
Frequently Asked Questions	19
Cooking Guide and Recipes	20

Limited Warranty

From the date of purchase for the designated time periods listed below, Sears will replace the following grill parts free of charge if they are defective in material or workmanship.

- Lifetime of Grill: Exterior Stainless Steel Parts, Aluminum Castings (except for paint loss)
- 3 Years: Flame Tamers, Cooking Grids, Burners
- 5 Years: All Other Grill Parts (except ignitor battery)

This warranty does not cover:

- Labor costs for repairs
- Grill if it is used for commercial or rental purposes.

Replacement parts are available by contacting the nearest Sears Service Center.

This warranty applies only when the grill is used in the United States.

This warranty gives you specific legal rights, and you may also have other rights which vary from state to state.

**Sears, Roebuck and Co., Dept. 817WA,
Hoffman Estates, IL 60179**

Read These Safety Instructions

WARNING

Failure to comply with these instructions could result in a fire or explosion which could cause serious bodily injury, death, or property damage.

Grill Installation Codes

This gas grill must be installed in accordance with all local codes. In areas without local codes, follow the latest edition of the National Fuel Gas Code ANSI Z223.1. In Canada, installation must conform to standard CAN/CGA 1b149.1 or 1-b149.2 (Installation Code for Gas Burning Appliances and Equipment) and all local codes.

Proper Placement and Clearance of Grill

Never use your gas grill in a garage, porch, shed, breezeway or any other enclosed area. Your gas grill is to be used **outdoors only**, at least 24" from the back and side of any combustible surface. Your gas grill should not be placed under any surface that will burn. Do not obstruct the flow of ventilation air around the gas grill housing.

This outdoor gas grill is not intended to be installed in or on recreational vehicles and/or boats.

Correct LPG Cylinder Use

LPG grill models are designed for use with a standard 20 lb. Liquid Propane Gas (LPG) cylinder, not included with grill box. **Never** connect your gas grill to an LPG cylinder that exceeds this capacity. A cylinder of approximately 12 inches in diameter by 18-1/2 inches high should be the maximum size LPG cylinder used. We recommend buying an "OPD" gas cylinder which offers an Overfill Prevention Device. This safety feature prevents the cylinder from being overfilled which can cause malfunction of the LPG cylinder, regulator and/or grill.

The LPG cylinder must be constructed and marked in accordance with specifications of the U.S. Dept. of Transportation (DOT). In Canada, the LPG cylinder must meet the Canadian Transportation and Communications (CTC) specifications. Also be sure:

1. The LPG cylinder has a shutoff valve, terminating in an LPG supply cylinder valve outlet, that is compatible with a Type 1 cylinder connection device. The LPG cylinder must also have a safety relief device that has a direct communication with the vapor space of the cylinder.
2. The cylinder supply system must be arranged for vapor withdrawal.
3. The LPG cylinder used must have a collar to protect the cylinder valve.

WARNING

Failure to comply with these instructions could result in a fire or explosion which could cause serious bodily injury, death, or property damage.

- **Never** connect an unregulated LPG cylinder to your gas grill. The gas regulator assembly supplied with your gas grill is adjusted to have an outlet pressure of 11" water column (W.C.) for connection to an LPG cylinder.
- Only use the regulator and hose assembly supplied with your gas grill. Replacement regulators and hose assemblies must be those specified by Sears.
- Have your LPG cylinder filled by a reputable propane gas dealer and visually inspected and re-qualified at each filling.
- **Never** fill the gas cylinder beyond 80% full. Have your propane gas dealer check the release valve after every filling to ensure that it remains free of defects.
- Always keep LPG cylinders in an upright position.
- Do not store (or use) gasoline or other flammable vapors and liquids in the vicinity of this gas grill.
- An LPG cylinder that is not connected for use must not be stored in the vicinity of this or any other gas grill.
- Do not subject the LPG cylinder to excessive heat.
- **Never** store an LPG cylinder indoors. If you store your gas grill in the garage or other indoor location, **always** disconnect the LPG cylinder first and store it safely outside.
- LPG cylinders must be stored outdoors in a well-ventilated area. Disconnected LPG cylinders must not be stored in a building, garage or any other enclosed area.
- When your gas grill is not in use the gas must be turned off at the LPG cylinder.
- The regulator and hose assembly must be inspected before each use of the grill. If there is excessive abrasion or wear or if the hose is cut, it must be replaced prior to the grill being used again.
- Keep the gas regulator hose away from hot grill surfaces and dripping grease. Avoid unnecessary twisting of hose. Visually inspect hose prior to each use for cuts, cracks, excessive wear or other damage.
- If the hose appears damaged do not use gas grill. Call Sears at 1-800-4-MY-HOME for a Sears authorized replacement hose.
- **Never** light your gas grill with the lid closed or before checking to insure the burner tubes are fully seated over the gas valve orifices.
- **Never** allow children to operate your grill. Do not allow children to play near your grill.

WARNING

IF YOU SMELL GAS:

- Shut off gas supply to the grill.
- Extinguish any open flame.
- Open grill lid.
- If odor continues, immediately call your gas company or local fire department.

Failure to comply with these instructions could result in a fire or explosion which could cause serious bodily injury, death, or property damage.

WARNING

A strong gas smell, or the hissing sound of gas indicates a serious problem with your gas grill or the LPG cylinder. Failure to immediately follow the steps listed below could result in a fire or explosion which could cause serious bodily injury, death, or property damage.

- Get away from the LPG cylinder.
- Do not try to fix the problem yourself.
- Call your fire department. (Do not call near the LPG cylinder because your telephone is an electrical device.)

CAUTION: BEWARE OF FLASH-BACK

CAUTION: Spiders and small insects occasionally spin webs or make nests in the grill burner tubes during transit and warehousing. These webs can lead to a gas flow obstruction which could result in a fire in and around the burner tubes. This type of fire is known as a "FLASH-BACK" and can cause serious damage to your grill and create an unsafe operating condition for the user.

Although an obstructed burner tube is not the only cause of "FLASH-BACK", it is the most common cause.

To reduce the chance of "FLASH-BACK", you must clean the burner tubes before assembling your grill, and at least once a month in late summer or early fall when spiders are most active. Also perform this burner tube cleaning procedure if your grill has not been used for an extended period of time.



Pre-Assembly Instructions

To reduce the chance of "FLASH-BACK" (see caution on page 3) clean the burner tubes and burners **before** fully assembling your grill. Remove the cotter pin from the rear underside of each burner using a pair of long nose pliers. Carefully lift each burner up and away from the gas valve orifice, then refer to **Figure 1** and perform one of these three cleaning methods:

1. Bend a stiff wire, (a lightweight coat hanger works well) into a small hook as shown below. Run the hook through the burner tube and inside the burner several times to remove any debris.
2. Use a bottle brush with a flexible handle. Run the brush through the burner tube and inside the burner several times, removing any debris.
3. Use an air hose to force air through each burner tube. The forced air should pass debris or obstructions through the burner and out the ports.



Figure 1

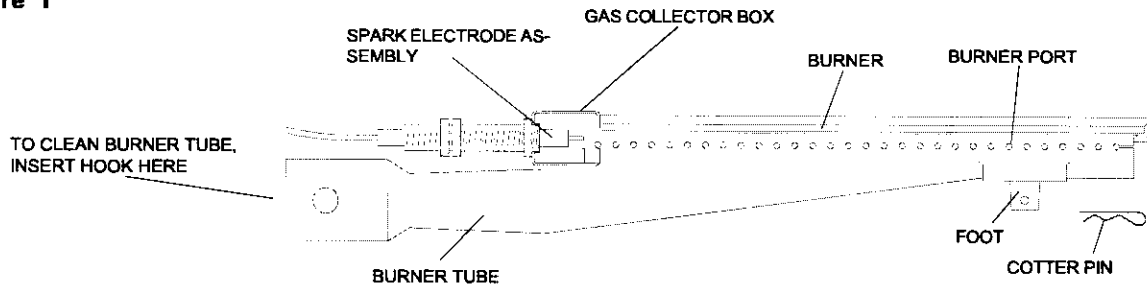

Tools Required for Assembly

- Size 2 phillips screwdriver
- Size 4 phillips screwdriver
- Adjustable wrench
- Long nose pliers
- Open-end wrench, 11/16" size
- Protective work gloves
- Eye protection

⚠ WARNING

The location of the burner tube with respect to the orifice is vital for safe operation. Check to ensure the orifice is inside of the burner tube before using your gas grill. See **Fig. 2**. If the burner tube does not fit over the valve orifice, lighting the burner may cause explosion and/or fire.

Figure 2

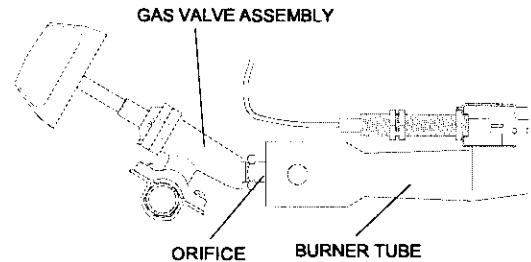

Contents for Hardware Pack (Part #P5591C)

The following table illustrates a breakdown of the hardware pack. It highlights what components are used in the various stages of assembly.

Ref.	Component	Qty. to Use	Purpose of Components
H005 H008	1/4"x1/2" Phillips Head Screw 1/4" Nut	4 4	Install Bottom Shelf To Cart Legs
H001 H002 H003	3/8" Wheel Bolt Spring Washer 3/8" Nut	2 2 2	Install Wheels To Cart Legs
H005 H008	1/4"x1/2" Phillips Head Screw 1/4" Nut	3 3	Install Rear Panel To Cart
H005 H008	1/4"x1/2" Phillips Head Screw 1/4" Nut	7 7	Install Top Panel and Bottom Shelf To Cart
H005 H008	1/4"x1/2" Phillips Head Screw 1/4" Nut	4 4	Install Door Stops To Cart
H007	M4x6mm Phillips Head Screw	4	Install Door Handles To Doors
H006	1/4"x5/8" Part-Threaded Bolt	4	Install Doors To Cart
H005	1/4"x1/2" Phillips Head Screw	1	Install Tank Holder To Cart
H005	1/4"x1/2" Phillips Head Screw	1	Install Tank Hook To Cart
H005	1/4"x1/2" Phillips Head Screw	4	Restrict Drawer From Being Pulled Out Too Far
H004 H009	1/4"x3/4" Phillips Head Screw 1/4" Lock Nut	4 4	Install Grill Head To Cart
H004	1/4"x3/4" Phillips Head Screw	8	Install Side Shelves To Cart
P0239A	Door Handle	2	Install To Front Doors
P5589A	Magnetic Door Stop	2	Install To Cart
P8080A	AA Battery	1	Install To Electric Ignitor
P80C4A	Flame Tamer Spacer	4	Install To Bowl Side Panels

Actual Size and Quantity of Each Hardware Piece:

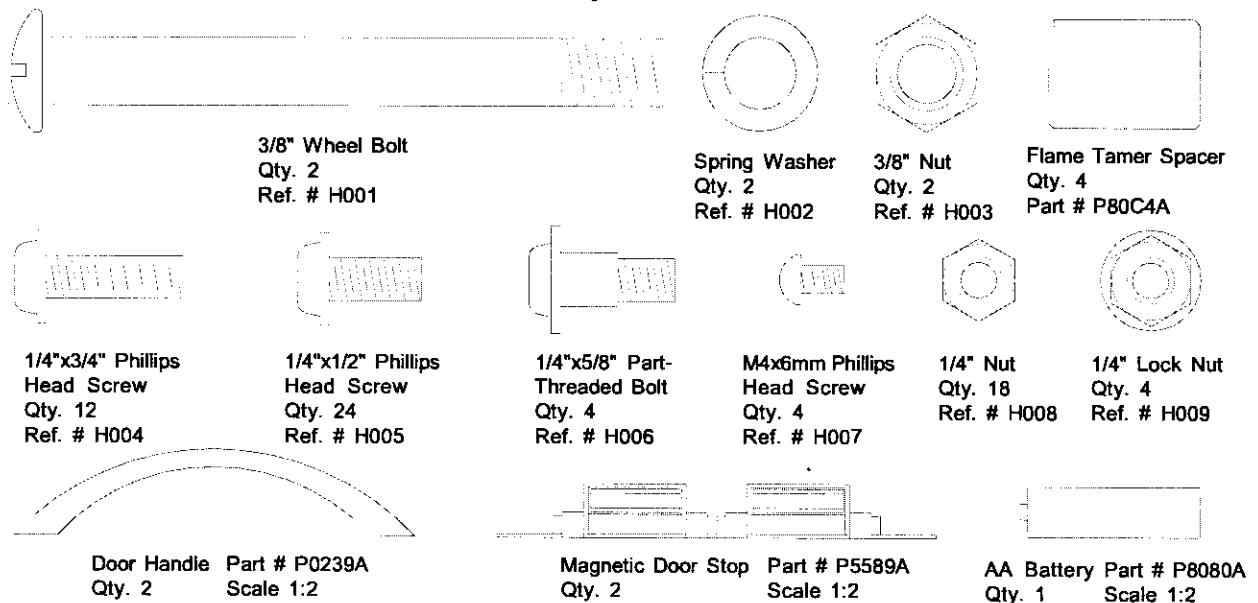

Parts Diagram

Remove all components from the packing carton and place within easy reach. Do not throw the shipping carton away; instead use it as an elevated assembly surface.

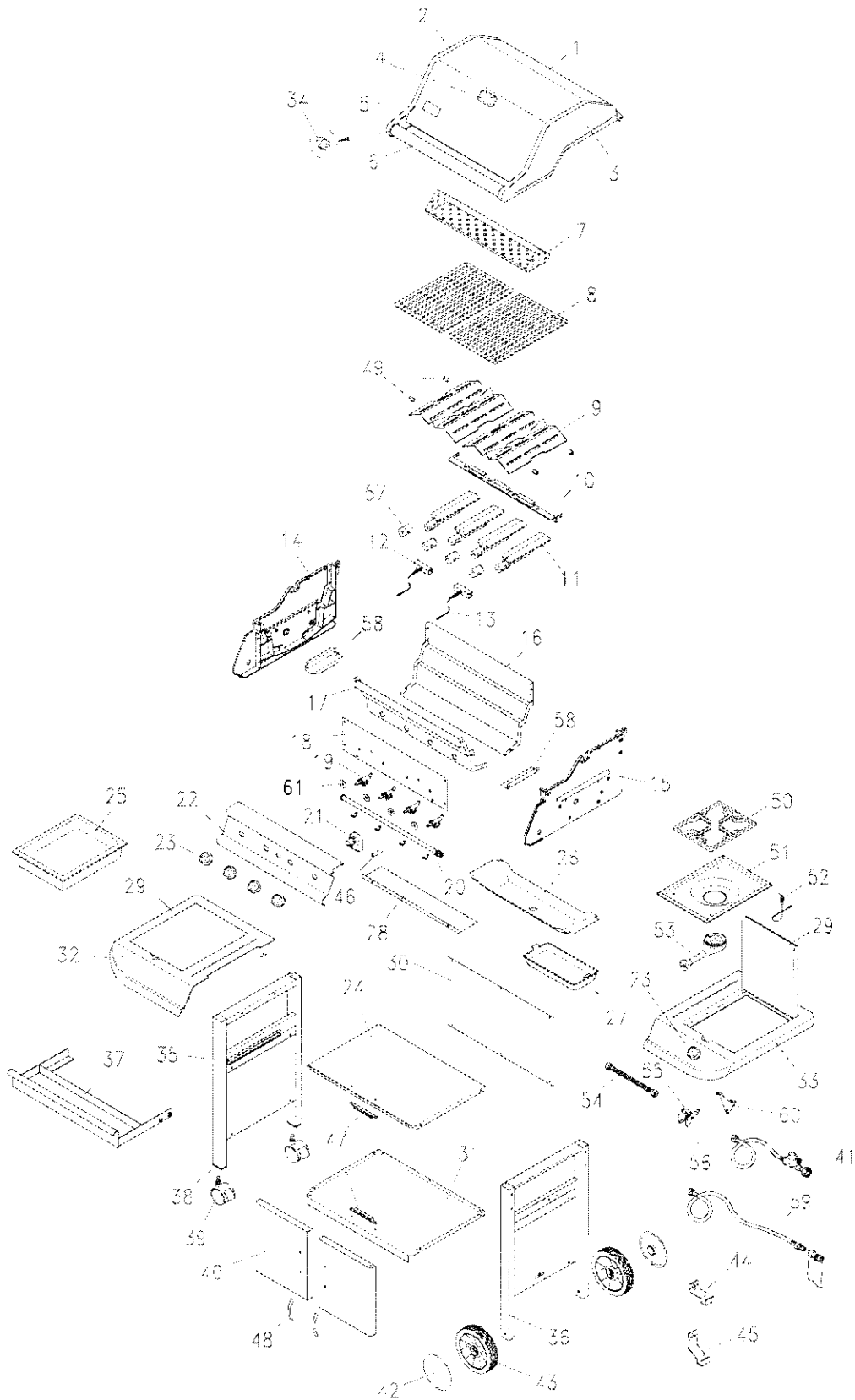

Parts List

REF#	DESCRIPTION	PART#	QTY	REF#	DESCRIPTION	PART#	QTY
1.	Lid - Stainless Steel	P0149F	1	41.	Regulator and Hose (L.P.G. only)	P3632E	1
2.	Lid Side Panel - Left	P0145B	1	42.	Wheel Hub - Graphite	P5113C	2
3.	Lid Side Panel - Right	P0144B	1	43.	Wheel - Graphite	P5106D	2
4.	Temperature Gauge	P0615B	1	44.	Tank Hook (L.P.G. only)	P4029A	1
5.	Name Plate	P0459A	1	45.	Tank Holder (L.P.G. only)	P4029B	1
6.	Lid Handle	P0237D	1	46.	AA Battery	P8080A	1
7.	Swing-Away Warming Rack	P1522A	1	47.	Magnetic Door Stop	P5589A	2
8.	Cast Iron Cooking Grid	P1648B	2	48.	Door Handle	P0239A	2
9.	Stainless Steel Flame Tamer	P1733A	2	49.	Flame Tamer Spacer	P80C4A	4
10.	Burner Support Bracket	P2218B	1	50.	Pot Support	P80C6A	1
11.	Burner	P1935A	4	51.	Side Burner Body - Inner	P2323B	1
12.	Gas Collector Box w/ Electrode	P2618A	2	52.	Electrode Assembly	P2627A	1
13.	Ignition Wire Set	P2626B	1	53.	Burner Assembly	P1922A	1
14.	Bowl Panel - Left	P0728D	1	54.	Connection Tube	P3983E	1
15.	Bowl Panel - Right	P0727D	1	55.	Adaptor	P3998A	1
16.	Bowl Panel - Rear	P0732B	1	56.	Gas Valve Assembly - L.P.G. - N.G.	P3298A P3298B	1
17.	Bowl Panel - Front	P0731B	1	57.	Air Shutter (N.G. only)	P80C7A	4
18.	Heat Shield	P2942B	1	58.	Grease Shield	P80C8A	2
19.	Gas Valve Assembly - L.P.G. - N.G.	P3297C P3297E	4	59.	N.G. 12' Hose Kit	P3718A	1
20.	Gas Manifold	P5028A	1	60.	Gas Valve Bracket	P80C9A	1
21.	Electric Ignitor	P2503C	1	61.	Rain Shield	P80D5A	4
22.	Control Panel	P2942A	1	—	Owner's Manual	P4775B	1
23.	Control Knob	P3409B	5	—	Hardware Pack (contents page 5)	P5591C	1
24.	Top Panel of Cabinet	P1042B	1	If your shipping box is missing parts or you have questions about assembly, call 8 am - 11 pm CST, Monday through Friday, 1-888-317-7642			
25.	Storage Bin	P1134A	1	For the repair or replacement parts you need: Call 6 am - 11 pm CST, 7 days a week 1-800-366-PART (1-800-366-7278)			
26.	Grease Draining Tray	P2725A	1	To make sure you obtain the correct replacement parts for your Kenmore Elite gas grill, please refer to the part numbers on this page. The following information is required to assure you receive the correct parts:			
27.	Grease Receptacle	P2717C	1	1. Grill Model Number (see AGA label on grill)			
28.	Lower Heat Shield	P2944A	1	2. Part Number			
29.	Insert Plate - Stainless Steel	P1131B	2	3. Part Description			
30.	Rear Panel	P4327A	1	4. Quantity of parts needed			
31.	Bottom Shelf of Cabinet	P1042A	1	Important: Keep this Owner's Manual for convenient referral and for part replacement.			
32.	Side Shelf	P1131E	1	Important: Use only Sears authorized parts. The use of any part that is not Sears authorized can be dangerous and will also void your product warranty.			
33.	Side Burner Body	P1137B	1				
34.	Heat-Insulating Spacer	P5573A	2				
35.	Cart Legs - Castor Side	P0932A	1				
36.	Cart Legs - Wheel Side	P0832A	1				
37.	Drawer - Stainless Steel	P8078E	1				
38.	Castor Seat	P4521A	2				
39.	Castor	P5109A	2				
40.	Front Door	P4328A	2				

Assembly Instructions

Before assembling your gas grill, use the parts list to check that all necessary parts have been included. Inspect grill and cart parts for damage as you proceed. Do not assemble or operate your grill if it appears damaged. If you have questions during the assembly process, call 1-888-317-7642, 8am - 11pm CST, Monday through Friday.

CAUTION:

While it is possible for one person to assemble this gas grill, have assistance from another person when handling some of the larger, heavier pieces, especially the grill head.

Remove all cart parts, hardware, and grill head from carton. Assemble the gas grill on a protective work surface to avoid scratching grill surfaces. Refer to parts list and hardware pack illustrations to help you assemble your grill.

Assembling The Grill Cart

1. Position Bottom Shelf (Parts List Item #31) with its front vertical ledge facing down. Before attaching the Cart Legs to the Bottom Shelf, make sure its 2 holes for Door Stop are located in the front. See Fig. 1. Install the Cart Legs-Castor Side on the left side of the Bottom Shelf, with the Drawer Channel facing in. The 90 degree lip on sides and back of Bottom Shelf must be on the outside of the Side Panels for proper fit. Secure using 2 of the 1/4"x1/2" Phillips head screws and nuts provided. Install the Cart Legs-Wheel Side to the other side of Bottom Shelf by using the same-sized screws and nuts.
2. Install Rear Panel to inside of Side Panels by using 3 of the 1/4"x1/2" Phillips head screws and nuts. See Fig. 2.
3. Screw the 2 Castors into Castor Seats (see bottom of Cart Legs-Castor Side). Turn the threaded castor stem by hand, clockwise until it stops. Tighten with an Open-end 11/16" wrench.
4. Install the 2 Wheels to the Cart Legs-Wheel Side, by inserting the wheel bolt through the wheel and axle hole on the cart leg as shown in Fig. 2. Put spring washer and 3/8" nut onto bolt and tighten securely using a size 4 phillips screwdriver. Do not overtighten or wheel will not turn freely. Snap Wheel Hubs onto the wheels.
5. Position Top Panel (Parts List Item #24) with its front vertical ledge facing up. Before installing the Top Panel, make sure its 2 holes for the Door Stop are located in the front. Place Top Panel into position, with the 90 degree lip on the outside of Rear Panel. See Fig. 3. Secure firmly using 7 of the 1/4"x1/2" Phillips head screws and nuts provided.

Figure 1

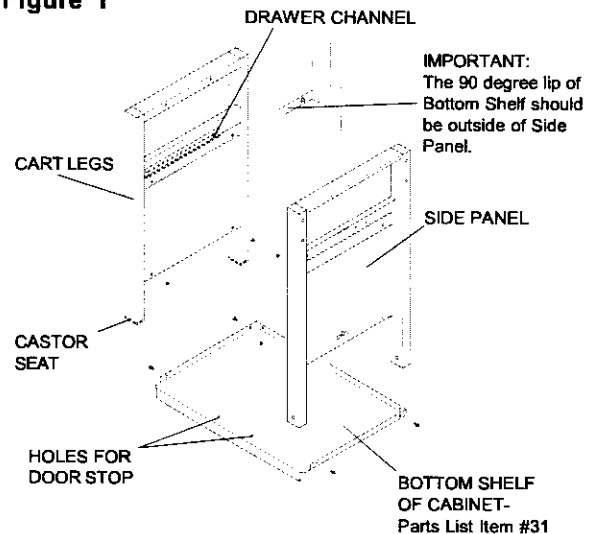

Figure 2

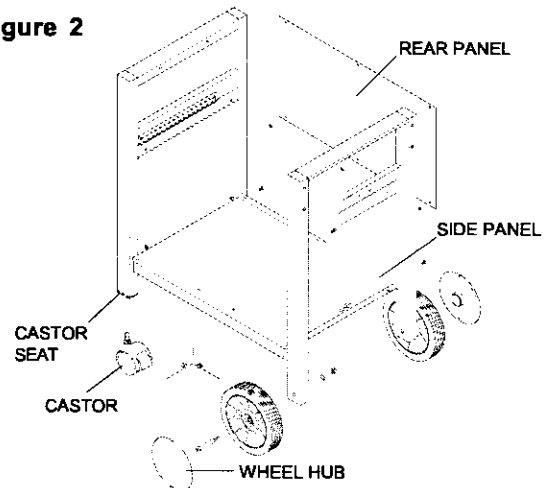
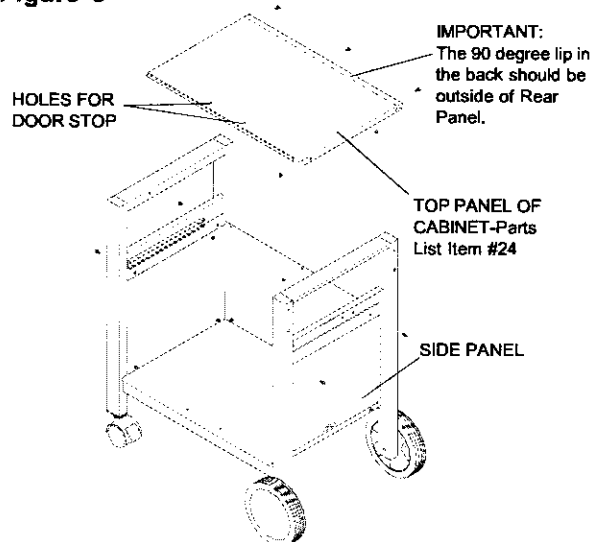

Figure 3



Assembling The Cabinet Doors

1. Install Door Stops to Bottom Shelf and Top Panel of Cabinet. See Fig. 4. Secure firmly using 4 of the 1/4"x1/2" Phillips head screws and nuts.
2. Remove the white protective film from the stainless steel Doors. Attach a Door Handle to each Front Door by using 2 of the M4x6mm Phillips head screws provided. See Fig. 5. Be careful not to scratch the door surfaces.
3. When installing the Front Doors, make sure the door bolt holes are located on the hinge sides of the Cart Legs.
4. Install either Front Door by inserting 1/4"x5/8" part-threaded bolt through the lower door bolt hole of the Front Door and into the tapped hole of the Bottom Shelf. Tighten securely. Next, align the upper door bolt hole of Front Door with the tapped hole in the Top Panel of Cabinet. Insert 1/4"x5/8" part-threaded bolt provided and tighten securely.
5. Repeat these steps to install the other Front Door.

How To Level The Grill Cart So The Doors Line-Up

When the top edge of the cabinet doors do not line-up your grill cart needs to be leveled. This step is often required after initial assembly and when your grill has been moved to a new location. To level your grill cart, use an 11/16" open-end wrench to unscrew the Castors counter-clockwise from their Castor Seats (see bottom of the Cart Legs) until the cabinet doors are aligned. See Fig. 5.

Figure 4

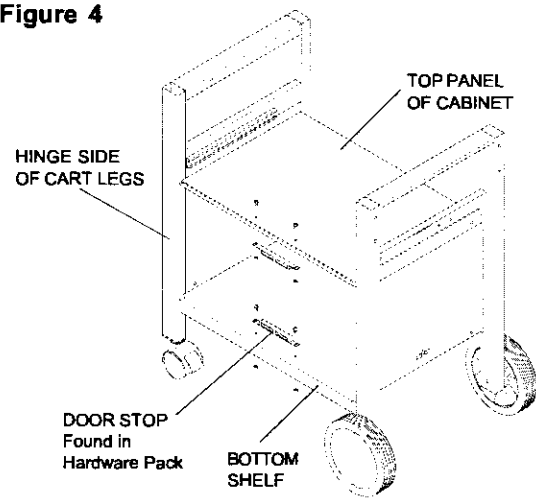
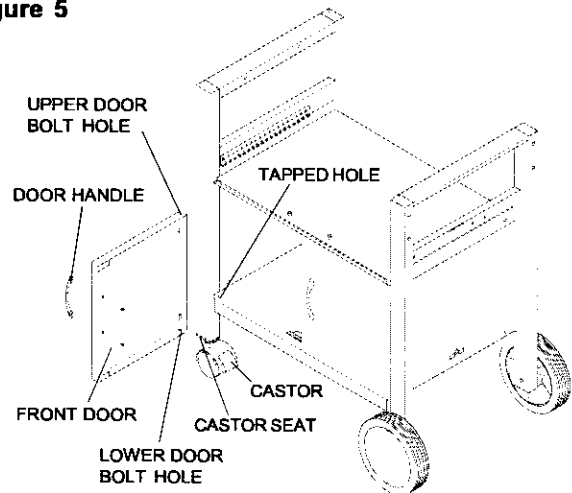

Figure 5



Assembling The Tank Hook and Grill Drawer

1. Attach the LPG Tank Hook and Tank Holder to the wheel-side of grill as shown in **Fig. 6**. Align the tapped holes of both parts with the holes on Side Panel. Secure firmly using 1/4"x1/2" Phillips head screws provided.
2. Install 2 of the 1/4"x1/2" Phillips head screws to the rear of the Drawer Track.
3. Slide the Drawer into the Drawer Tracks until it stops. See **Fig. 7**.
4. Install 2 of the 1/4"x1/2" Phillips head screws to the front of the Drawer Track. This important step prevents the drawer from being pulled outside the tracks. See **Fig. 7**.

Installing The Grill Head

1. Now that you've assembled the grill cart you can install the pre-assembled Grill Head. See **Fig. 8**. To reduce the weight of the Grill Head, we suggest you open the Grill Lid and remove the packed components. Even with the components removed, this step requires 2 people to lift and position the Grill Head onto the grill cart. Be sure to align the 2 holes beneath the hang ledge on each side of the Grill Head with the 2 holes on each cross brace of cart. Raise Grill Lid and insert 4 of the 1/4"x3/4" Phillips head screws and lock nuts and tighten securely.
2. From the back side of grill head, install the Grease Draining Tray. See **Fig. 8**.
3. Center the Grease Receptacle under Grease Draining Tray. See **Fig. 8**.

Figure 6

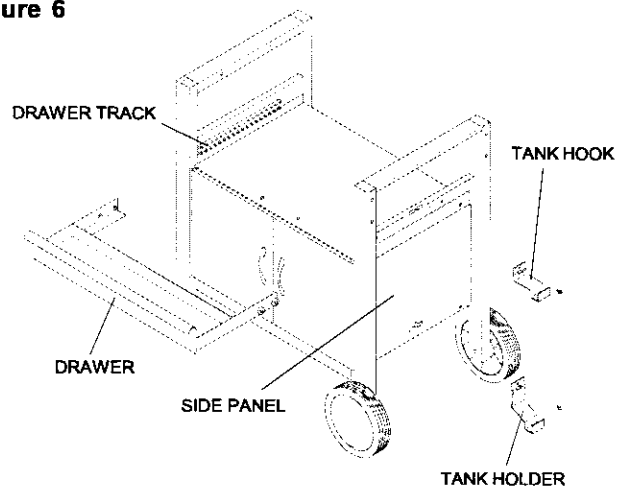

Figure 7

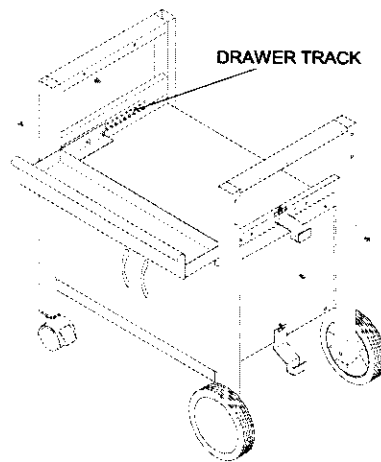
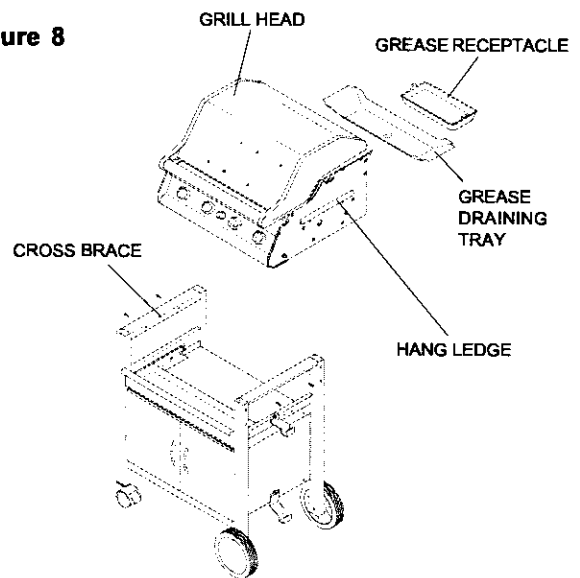

Figure 8



Installing Side Shelf and Side Burner

1. Remove and discard the protective rubber boots from the Side Shelf and Side Burner braces. Attach Side Shelf and Side Burner to Cart Legs as shown in Fig. 9. Align the 4 holes on Side Shelf and Side Burner frame with the holes on the Cart Legs. Tighten securely using 4 of the 1/4"x3/4" Phillips head screws provided.
2. Place a Storage Bin into Side Shelf.
3. Install Connection Tube between the inlet of Gas Manifold and Brass Adaptor of Gas Valve Assembly as illustrated in Fig. 9.
4. For LPG gas grills: Connect the hose end fitting of LPG Gas Regulator to the opening end of Adaptor. Tighten securely with a wrench.
5. For Natural Gas grills: Connect the 12' Natural Gas Hose between your gas grill, see Fig. 9A and the natural gas line at your home following the instructions included with your natural gas hose. Also read the natural gas safety instructions below.
6. On both LPG and natural gas grills, connect the Ignition Wire terminal from Side Burner with the other from Grill Head. See Fig. 9. Bind the connected Ignition Wires and Connection Tube together using the supplied Fastening Band.

Natural Gas Safety Instructions

- Your natural gas grill is designed to operate on natural gas only, at a pressure of 7" water column (W.C.) (1/4 psig or 1.75 kpa), regulated at the residential meter. Check with your gas utility company for local gas pressure and with your local municipality for building code requirements. If your residential gas line pressure has not been regulated to 7" W.C., contact your local gas utility company for professional assistance.
- It is recommended that a Shutoff Valve be installed at the gas supply source outdoors after the gas pipe exits the outside wall and before the quick-disconnect hose or, before the gas line piping enters the ground.
- Pipe sealing compound or pipe thread tape resistant to the action of natural gas must be used on all male pipe threads when making the connection.
- Disconnect your gas grill from fuel source when the gas supply is being tested at high pressures. This gas grill and its individual shutoff valve must be disconnected from the gas supply pipe system during any pressure testing of that system at pressure in excess of 1/2 psi (3.5kpa).
- Turn off your gas grill when the gas supply is being tested at low pressures. The grill must be isolated from the gas supply pipe system by closing its individual manual shutoff valve during any pressure testing of the gas supply pipe system at pressures equal to or less than 1/2 psi (3.5kpa).

Figure 9

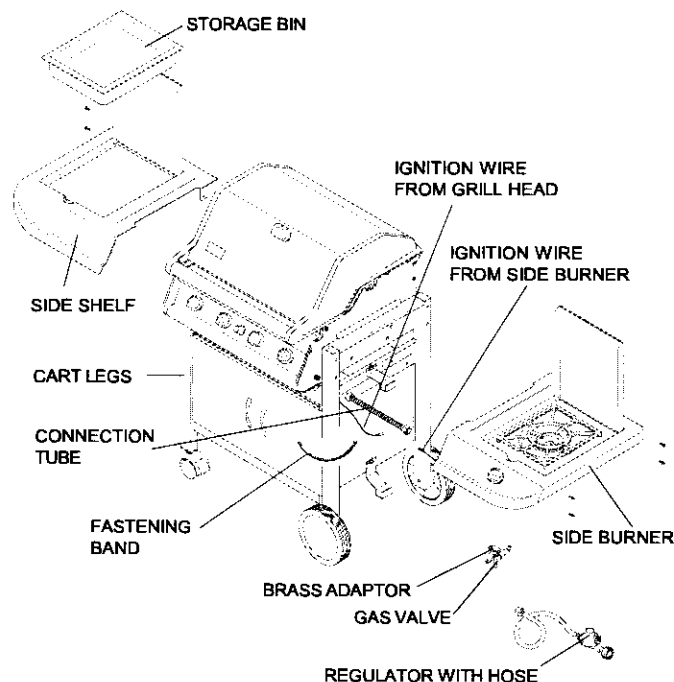
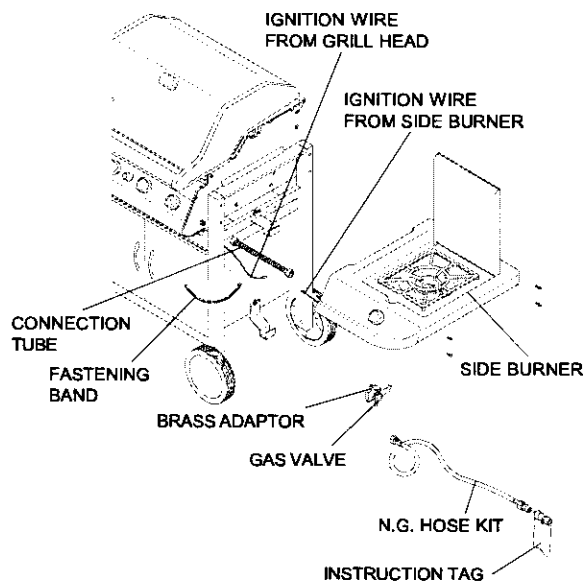

Figure 9A



Ignitor Battery Installation - See Fig. 10

1. Unscrew the Ignitor Cap located on the grill Control Panel and remove the Contact and Spring from the Ignitor Slot.
2. Place the manufacturer supplied AA battery into the Ignitor Slot. Be sure to place the positive pole facing toward you. See Fig. 10.
3. Place the Spring over the AA battery, then place the Contact on top of the Spring. Screw the Ignitor Cap back onto the grill Control Panel.

Figure 10

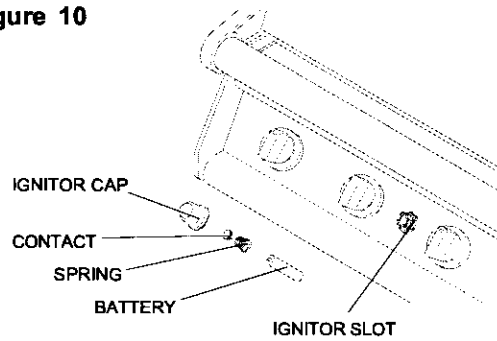

Electrode Check - Requires an Assistant

Before placing the cooking components into your grill, ensure that the Spark Electrode Tip is properly positioned within each Gas Collector Box (a 3-1/4" wide stainless mechanism found at the front between each set of burners.) The easiest way to ensure this is to perform the following Electrode Check:

Figure 11 - Side View

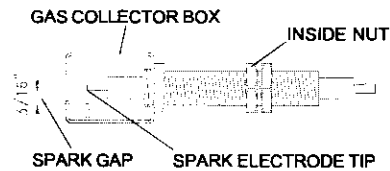

1. Be sure all Control Knobs are set to "OFF".
2. Have an assistant stand behind to the right of the grill and look down at each Gas Collector Box. NEVER put your face inside the grill bowl.
3. Press the Ignitor Cap and have the assistant watch for a small blue spark within each Gas Collector Box. If a spark is present the Electrode Tips are properly positioned.
4. If no spark is seen the Spark Gap shown in Fig. 11 needs to be adjusted as follows:
 - Using an adjustable wrench, loosen the Inside Nut just until the Gas Collector Box can be maneuvered and turned upward.
 - The gap between the Spark Electrode Tip and the bottom of the Gas Collector Box should be approximately 3/16".
 - If the gap is wider than 3/16" use a pair of long nose pliers and gently squeeze the Gas Collector Box until the gap is correct.
 - Return the Gas Collector Box to its original horizontal position, secure the Inside Nut and try the Electrode Check again.

Installing Cooking Components

Important: Before cooking on your grill the first time, wash the cooking grids and warming rack with warm, soapy water. Rinse and dry thoroughly. Season with cooking oil regularly. (After cooking is completed, turn grill to HIGH setting for about five minutes to burn off excess grease or food residue.)

1. Screw the 4 Flame Tamer Spacers on the Bowl Side Panels. See Fig. 12. Place the 2 Stainless Steel Flame Tamers on the lower ledge above burners. They should meet in the center.
2. Evenly space the reversible Cast Iron Cooking Grids on the ledge above the Stainless Steel Flame Tamers.
3. The inside of the Grill Lid has a U-shaped support on each side. Place the arms of the swing-away Warming Rack into both supports.

Connecting A Liquid Propane Gas (LPG) Cylinder To Your Grill

1. Hang your filled gas cylinder on the top Tank Hook. The ring foot of the gas cylinder will rest on the Tank Holder. See Fig. 13. Make sure the LPG cylinder valve is in the full OFF position. (Turn clockwise to close.)
2. Check the cylinder valve features to ensure it has proper external mating threads to fit the hose & regulator assembly provided. (Type 1 connection per ANSI Z21.58a-1998)
3. Make sure all burner valves are in the OFF position.
4. Inspect the valve connection port and regulator assembly. Look for any damage or debris. Remove any debris. Inspect hose for damage. Never attempt to use damaged or plugged equipment.
5. When connecting the hose and regulator assembly to the cylinder valve, hand tighten nut clockwise to a full stop. Do Not use a wrench to tighten because it could damage the Quick Coupling Nut and result in a hazardous condition.
6. Open the cylinder valve fully (counterclockwise). Use a soapy water solution to check all connections for leaks before attempting to light your grill. If a leak is found, turn the cylinder valve off and do not use your grill until repairs are made.

Disconnecting A Liquid Propane Gas (LPG) Cylinder From Your Grill

1. Turn the burner valves and LPG cylinder valve to the full OFF position. (Turn clockwise to close.)
2. Detach the hose and regulator assembly from the LPG cylinder valve by turning the Quick Coupling Nut counterclockwise.

Figure 12

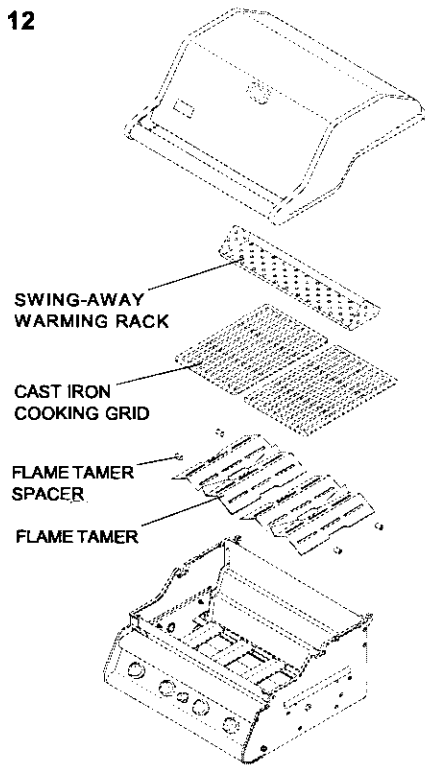
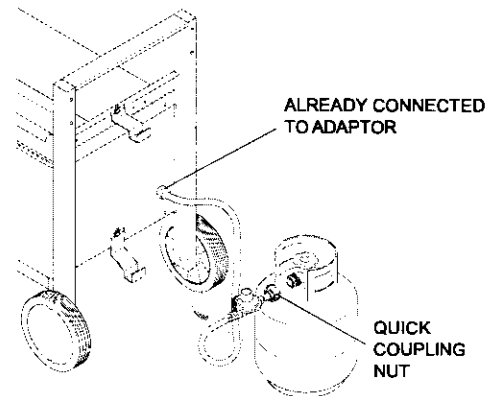

Figure 13



CAUTION: When the appliance is not in use, the gas must be turned off at the supply cylinder.

Congratulations

Your Kenmore Elite gas grill is now ready for use. Before the first use and at the beginning of each season (and whenever the LPG gas cylinder has been changed):

1. Read all safety, lighting and operating instructions.
2. Check gas valve orifices, burner tubes and burner ports for any obstructions.
3. Perform gas leak check according to instructions found on page 14 of this manual.

Lighting Instructions

Basic Lighting Procedures

1. Familiarize yourself with the safety guidelines at the front of this manual. Do not smoke while lighting grill or checking gas supply connections.
2. Be sure the LPG cylinder is filled.
3. Check that the end of each burner tube is properly located over each valve orifice.
4. Make sure all gas connections are securely tightened.
5. Open the Grill Lid or Side Burner Insert Plate.

⚠ WARNING

Failure to open Grill Lid or Insert Plate during the lighting procedures could result in a fire or explosion which could cause serious bodily injury, death, or property damage.

6. Set control knobs to OFF and open the LPG cylinder valve.
7. Push and turn one control knob to HIGH.
8. Then immediately press the electric ignitor for 3-4 seconds to light the burner.
9. If the burner does not light, turn the control knob to OFF, wait 5 minutes for gas to clear, then retry.
10. Once the first grill burner is ignited, the adjacent burner can be lit by simply turning it's control knob to HIGH.
11. Adjust control knobs to your desired cooking temperature.

⚠ WARNING

IF YOU SMELL GAS:

- Shut off gas supply to the grill.
- Extinguish any open flame.
- Open grill lid.
- If odor continues, immediately call your gas company or local fire department.

Failure to comply with these instructions could result in a fire or explosion which could cause serious bodily injury, death, or property damage.

Checking For LP Gas Leaks

Never test for leaks with a flame. Prior to first use, at the beginning of each season, or every time your LPG cylinder is changed, you must check for gas leaks. Follow these four steps:

1. Make a soap solution by mixing one part liquid detergent and one part water.
2. Turn the grill control knobs to the full OFF position, then turn the gas ON at source.
3. Apply the soap solution to all gas connections. Bubbles will appear in the soap solution if the connections are not properly sealed. Tighten or repair as necessary.
4. If you have a gas leak that you cannot repair, turn off the gas at the source, disconnect fuel line from your grill and call 1-800-4-MY-HOME or your gas supplier for repair assistance.

⚠ WARNING

A strong gas smell, or the hissing sound of gas indicates a serious problem with your gas grill or the LPG cylinder. Failure to immediately follow the steps listed below could result in a fire or explosion which could cause serious bodily injury, death, or property damage.

- Get away from the LPG cylinder.
- Do not try to fix the problem yourself.
- Call your fire department. (Do not call near the LPG cylinder because your telephone is an electrical device.)

Lighting Your Grill by Match

To light your gas grill by match, follow steps 1 through 6 of the Basic Lighting Procedures. Then, insert a lit match through the lighting hole on either side of the grill. See Fig. 14. Turn the nearest control knob to the HIGH setting to release gas. The burner should light immediately.

Figure 14

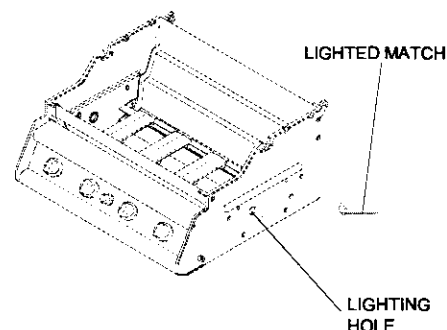

⚠ WARNING

Never lean over the grill cooking area while lighting your gas grill. Keep your face and body a safe distance (at least 18 inches) from the lighting hole or burners, when lighting your grill by match.

If the grill fails to light properly:

1. Turn gas off at source and turn the control knob to OFF. Wait at least five minutes for gas to clear, then retry.
2. Check gas supply and connections.
3. Repeat lighting procedure. If your grill still fails to operate properly, turn the gas off at source, turn the control knobs to OFF, then check the following:
 - Misalignment of burner tubes over orifices
Correction: Reposition burner tubes over orifices.
 - Obstruction in gas line
Correction: Remove fuel line from grill. Do not smoke! Open gas supply for one second to clear any obstruction from fuel line. Close off gas supply at source and reconnect fuel line to grill.
 - Plugged orifice
Correction: Remove burners from grill by pulling cotter pin (beneath burner) using a screwdriver or pliers. Carefully lift each burner up and away from gas valve orifice. Remove the orifice from gas valve and gently clear any obstruction with a fine wire. Then reinstall all orifices, burners, cotter pins and cooking components.

If an obstruction is suspected in gas valves or gas valve bracket, please call for repair service at 1-800-4-MY-HOME.

Misalignment of ignitor on burner
 - **Correction:** Check for proper position of the electrode tip. The tip of the electrode should be pointing toward the bottom of the collector box, as shown in **Figure 11**. The gap between the spark electrode and the bottom of the gas collector box should be 3/16". Adjust if necessary. With the gas supply closed and all control knobs set to OFF press the electric ignitor cap and check for the presence of a spark at the electrode.

Disconnected Ignition Wires
 - **Correction:** Inspect the Ignitor junction box found beneath the Control Panel. Connect loose Ignitor wires to the junction box and try to light the grill.

Weak AA battery
 - **Correction:** Unscrew the Ignitor Cap and replace the battery.
4. If all checks or corrections have been made and your grill still fails to operate properly, call 1-800-4-MY-HOME for repair service.

⚠ WARNING

Should a "FLASH-BACK" fire occur in/or around the burner tubes, follow the instructions below. Failure to comply with these instructions could result in a fire or explosion which could cause serious bodily injury, death, or property damage.

- Immediately turn the gas OFF at its source.
- Turn the control knobs to OFF position.
- Once the grill has cooled down, clean the burner tubes and burners according to the cleaning instructions found on page 17 in this manual.

Cooking Instructions

Burn-off

Before cooking on your gas grill for the first time, you will want to "burn off" the grill to eliminate any odor or foreign matter. Just ignite the burners, close the lid, and operate grill on the HIGH setting for about five minutes.

CAUTION:

Operating your grill on the HIGH setting for longer than five minutes may damage certain parts of your grill. **Do not leave your grill unattended.**

Preheating

To preheat, light your grill on HIGH, close the lid and follow this timetable:

- For high temperature cooking, preheat grill 5 minutes.
- For low temperature cooking, preheat grill 3 minutes.
- To slow cook, preheating is not necessary.

Cooking Temperatures

High setting: Only use this setting for fast warm-up, searing steaks or chops and for burning food residue off the grill after cooking is complete. **Never** use the HIGH setting for extended cooking.

Medium to Low settings: Most recipes specify medium to low settings, including all smoking, rotisserie cooking and for cooking lean cuts such as fish.

NOTE: Temperature settings will vary with the amount of wind and temperature outside your home.

Direct Cooking

The direct cooking method can be used with the supplied cast-iron grids, optional griddle or cooking pan placed directly over the lit grill burners. **Direct cooking requires the grill lid to be open.** This method is ideal for searing and whenever you want meat, poultry or fish to have an open-flame barbecued taste. Deep frying and smoking are also best cooked in this manner because they require direct heat.

Indirect Cooking

The indirect cooking method can also be used with the supplied cast-iron grids, optional griddle or cooking pan. To cook **indirectly**, the food should be placed on the left or right side of your grill with the burner lit on the opposite side. Or place your food on the warming rack mounted inside your grill lid and light the outer grill burners. Either way, **indirect cooking must be done with the lid down.**

Seasoning Cast-Iron

Before and after each cookout, apply a thin layer of cooking oil, spray or vegetable shortening to each cooking grid. Be sure to coat the entire surface including edges and any areas with chipped porcelain. Insert the cooking grids into your warm grill for 2 to 3 minutes.

Flare-Ups

The fats and juices dripping from grilled food can cause flare-ups. Since flare-ups impart a favorably distinctive taste and color to food cooked over an open flame, they should be accepted up to a point. Nevertheless, uncontrolled flaring can result in a ruined meal.

WARNING

Your grill will get very hot. Never lean over the cooking area while using your grill. Do not touch cooking surfaces, grill housing, grill lid or any other grill parts while the grill is in operation, or until the grill has cooled down after use.

Failure to comply with these instructions may result in serious bodily injury.

Cleaning and Maintenance

As with all appliances, proper care and maintenance will keep your grill in top operating condition and prolong its life. By following these cleaning procedures on a timely basis, your grill will stay clean and work properly with minimum effort.

Cleaning The Cooking Grids

Before initial use and periodically we suggest you wash your cooking grids in a mild soap and warm water solution. You can use a wash cloth or vegetable brush to clean your cooking grids.

CAUTION:

Take care not to chip or scratch the porcelain finish because it will void your warranty. **Never** try to clean your cooking grids unless you are sure the grids are cool to the touch.

Cleaning The Flame Tamers

Periodically you should wash the Flame Tamers in a soap and warm water solution. Use a wire brush to remove stubborn burnt-on cooking residue. Dry the Flame Tamers thoroughly before you reinstall them into the cooking bowl.

Cleaning The Grease Tray and Receptacle

To reduce the chance of fire, the Grease Draining Tray and Grease Receptacle should be visually inspected before each grill use. Remove any grease and wash grease tray and receptacle with a mild soap and warm water solution.

Cleaning The Burner Tubes and Burner Ports

To reduce the chance of "FLASH-BACK" the procedure below should be followed at least once a month in late summer or early fall when spiders are most active or when your grill has not been used for a period of time.

1. Turn all burner valves to the full OFF position.
2. Turn the LPG cylinder valve or NG Shutoff Valve to the full OFF position.
3. Detach the LPG regulator assembly or NG hose assembly from your gas grill.
4. Remove the cooking grids, flame tamers, and grease trays from your grill.
5. Remove the cotter pin from the rear underside of each burner using a pair of long nose pliers.
6. Carefully lift each burner up and away from the gas valve orifice.
7. Refer to **Fig. 1** and perform one of these three cleaning methods:

- Bend a stiff wire, (a lightweight coat hanger works well) into a small hook as shown below. Run the hook through the burner tube and inside the burner several times to remove any debris.



- Use a bottle brush with a flexible handle. Run the brush through the burner tube and inside the burner several times, removing any debris.
- Use an air hose to force air through each burner tube. The forced air should pass debris or obstructions through the burner and out the ports.

Figure 1

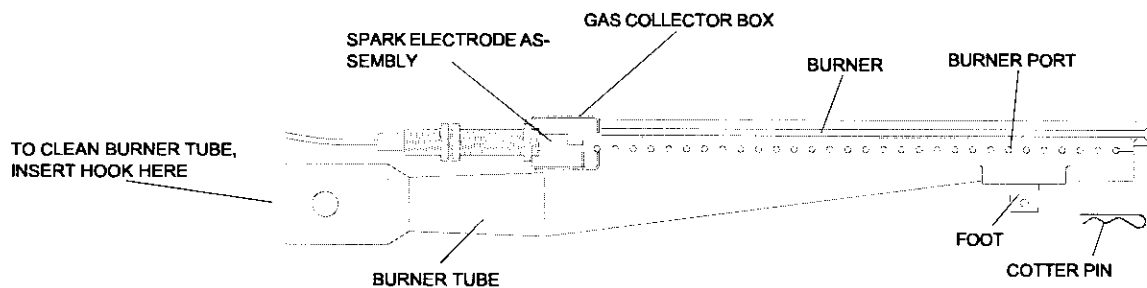

Regardless of which burner cleaning procedure you use, we recommend you also complete the following steps to help prolong burner life.

1. Use a wire brush to clean the entire outer surface of each burner until free of food residue and dirt.
2. Clean any clogged ports with a stiff wire, such as an open paper clip.
3. Inspect each burner for damage (cracks or holes) and if such damage is found, order and install a new burner. After installation, check to insure that the gas valve orifices are correctly placed inside the ends of the burner tubes. Also check the position of your spark electrode.

⚠ WARNING

The location of the burner tube with respect to the orifice is vital for safe operation. Check to ensure the orifice is inside of the burner tube before using your gas grill. See **Fig. 2**. If the burner tube does not fit over the valve orifice, lighting the burner may cause explosion and/or fire.

Figure 2

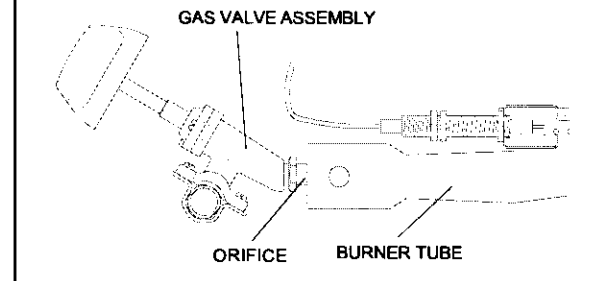

CAUTION:

Be sure your grill is OFF and cool before cleaning. Take care not to chip or scratch the painted surfaces because it will void your warranty.

Annual Cleaning of The Grill Interior

Burning-off the grill after every cookout will keep it ready for instant use. However, once a year you should give the entire grill a thorough cleaning to keep it in top operating condition. Follow these steps:

1. Turn all burner valves to the full OFF position.
2. Turn the LPG cylinder valve or NG Shutoff Valve to the full OFF position.
3. Detach the LPG regulator assembly or NG hose assembly from your gas grill.
4. Remove and clean the flame tamers, cooking grids and grill burners.
5. Cover each gas valve orifice with aluminum foil.
6. Brush the inside and bottom of the grill with a stiff wire brush, and wash with a mild soap and warm water solution. Rinse thoroughly and let dry.
7. Remove aluminum foil from orifices and check each orifice for obstruction.
8. Check each spark electrode, adjusting as needed. The Electrode tip should be pointing toward the bottom of the gas collector box and approximately 3/16" from the bottom of the collector box.
9. Replace the burners and adjust the gas collector box. The edge of the collector box should be overlapping the burner port.
10. Replace flame tamers and the cooking grids.
11. Reconnect the gas source and observe the burner flame for correct operation.

 **WARNING**

Do not line the bottom of the grill housing with aluminum foil, sand or any substance that will restrict the flow of grease into the grease draining tray and receptacle.

Failure to comply with these instructions could result in a fire or explosion which could cause serious bodily injury, death, or property damage.

Cleaning Exterior Surfaces:

Before initial use, and periodically thereafter, we suggest you wash your grill using a mild soap and warm water solution. You can use a wash cloth or sponge for this process. Do not use a stiff wire or brass brush that might remove paint during the cleaning process.

Cleaning Exterior Stainless Steel Surfaces:

Weathering and extreme heat can cause exterior stainless steel surfaces to turn tan in color. Follow these steps for the best cleaning results.

1. Turn the LPG cylinder valve (clockwise) to the full OFF position. Disconnect the regulator and hose assembly from LPG cylinder. Cover exposed gas fitting with aluminum foil.
2. Remove dirt or grease using a soft cloth and polish stainless surfaces using a Stainless Steel Foam Cleaner. Never use abrasive cleaners or scrubbers—they will scratch and damage your stainless steel.
3. Wipe with a soft cloth and allow to air dry before lighting your grill.

Frequently Asked Questions

Question: Who do I call with questions about grill assembly or parts missing from my shipping box?

Answer: Call the Customer Service Helpline 8 am - 11 pm CST, Monday through Friday, at 1-800-317-7642.

Question: Can I convert my Kenmore Elite gas grill from one fuel type to another?

Answer: Your Kenmore Elite gas grill is manufactured to exact specifications and is approved by the American Gas Association (AGA) for LPG or NG use only. For your own safety, conversion kits are not available and any attempt to convert your grill from one fuel type to another will void your product warranty.

Question: Are the serial and model numbers of my grill listed somewhere for future reference?

Answer: Yes, this valuable information is listed on a silver label found on the back of your grill.

Question: Why doesn't the hose and regulator assembly supplied with my new Kenmore Elite grill fit the older LPG cylinder I've used for years?

Answer: The U.S. Government regulates gas appliances and LPG cylinders. Whenever new regulations are passed the LPG cylinder fittings are altered. If your current cylinder does not fit the hose and regulator supplied with your new grill, the cylinder is outdated and must be replaced.

Question: What is the best way to protect my new Kenmore Elite gas grill?

Answer: A good quality grill cover should be used to protect your grill when not in use. Also, follow the cleaning and maintenance instructions in this owner's manual on a timely basis, and your new grill will offer you years of enjoyment.

Question: I understand rusting is a natural oxidation process, but what can I do to help prevent the cast-iron cooking grids from rusting?

Answer: To protect against the natural rusting process, your cast-iron cooking grids have a porcelain finish. However, dropping, scraping or scratching the cooking grids will damage the porcelain finish and allow rusting. To minimize rusting we recommend you "season" the cast-iron cooking grids regularly—before and after each use. Consistent seasoning will help cast-iron resist rusting and will create a non-stick cooking surface.

Question: How do I season cast-iron?

Answer: Before and after each cookout, apply a thin layer of cooking oil, spray or vegetable shortening to each cooking grid. Be sure to coat the entire surface including edges and any areas with chipped porcelain. Preheat your grill for 2 to 3 minutes then insert the cooking grids. The cooking grids will be seasoned and ready for use after 5 minutes in your warm grill.

Question: Sometimes my grill does not light when I push the ignitor button. Why?

Answer: Refer to the Lighting Instructions in this owner's manual. Also check these common causes.

- Ignitor AA battery may need replacing.
- Ignitor wires may be loose. Remove the AA battery, inspect the Ignitor junction box found beneath the Control Panel, and connect any loose wires.

Question: Where can I buy replacement parts?

Answer: For the repair or replacement parts you need call 6 am - 11 pm CST, 7 days a week 1-800-366-PART (1-800-366-7278). Use only Sears authorized parts. The use of any part that is not Sears authorized can be dangerous and will also void your product warranty.

Cooking Guide

Burn-off

Before cooking on your gas grill for the first time and after every meal, you will want to "burn off" the grill to eliminate any odor or foreign matter. Just ignite the burners, close the lid, and operate grill on the HIGH setting for about five minutes.

CAUTION:

Operating your grill on the HIGH setting for longer than five minutes may damage certain parts of your grill. **Do not leave your grill unattended.**

Preheating

To preheat, light your grill on HIGH, close the lid and follow this timetable:

- For high temperature cooking, preheat grill 5 minutes.
- For low temperature cooking, preheat grill 3 minutes.
- To slow cook, preheating is not necessary.

Cooking Temperatures

High setting: Only use this setting for fast warm-up, searing steaks or chops and for burning food residue off the grill after cooking is complete. **Never** use the HIGH setting for extended cooking.

Medium to Low settings: Most recipes specify medium to low settings, including all smoking, rotisserie cooking, and for cooking lean cuts such as fish.

NOTE: Temperature settings will vary with the amount of wind and temperature outside your home.

Direct Cooking

The direct cooking method can be used with the supplied cast-iron grids, optional griddle or cooking pan placed directly over the lit grill burners. **Direct cooking requires the grill lid to be open.** This method is ideal for searing and whenever you want meat, poultry or fish to have an open-flame barbecued taste. Deep frying and smoking are also best cooked in this manner because they require direct heat.

Indirect Cooking

The indirect cooking method can also be used with the supplied cast-iron grids, optional griddle or cooking pan. To cook **indirectly**, the food should be placed on the left or right side of your grill with the burner lit on the opposite side. Or place your food on the warming rack mounted inside your grill lid and light the outer grill burners. Either way, **indirect cooking must be done with the lid down.**

Seasoning Cast-Iron

Before and after each cookout, apply a thin layer of cooking oil, spray or vegetable shortening to each cooking grid. Be sure to coat the entire surface including edges and any areas with chipped porcelain. Insert the cooking grids into your warm grill for 2 to 3 minutes.

Flare-Ups

The fats and juices dripping from grilled food can cause flare-ups. Since flare-ups impart a favorably distinctive taste and color to food cooked over an open flame, they should be accepted up to a point. Nevertheless, uncontrolled flaring can result in a ruined meal.

An Important Note About Heat Settings

The suggested heat settings shown on the following pages are approximate. There are many factors such as outside temperature, wind conditions and location of grill that affect your grill performance. An overcooked meal can ruin the fun, so we offer these cooking times as a convenience, but suggest you watch the grill thermometer and adjust the heat accordingly.

GRILLING TECHNIQUES

Grilling is a **low fat** cooking technique that lends itself to a wide range of foods. Your Kenmore Elite gas grill is a fast heating grill that produces the barbecued **appearance and flavor** everyone enjoys so much. You can expand a dinner for two to a neighborhood block party by simply purchasing larger cuts and quantities of meat which cook beautifully on your new grill. This technique doesn't require much experience or skill on your part to produce a superb supper.

Preparing to Grill

Preheat your grill for 5 minutes with the burners on high and the grill lid down. Before placing the food onto the grill, brush the cooking grids with a light coating of cooking oil. This step isn't necessary when foods have been marinating in an oil-based marinade.

Your Kenmore Elite gas grill is **now ready to grill.** Remember to keep the lid open when cooking directly on the grill. For most foods it's best to start grilling on high. Once the food is seared, reduce the heat to medium. Foods marinated with ingredients such as honey may burn because of the high sugar content. You should begin their cooking on medium. A favorite on the grill is sausages. Always cook them slowly and if they're particularly fatty, it may be best to partially boil them first.

Guide to Grilling Meat and Poultry

Grilling Steak and Ribs

Turn the grill burners on high, close the lid and preheat your grill 5 minutes. After 5 minutes place the meat on the cooking grid directly above the lit burners. Cook the meat on both sides until seared. Reduce the heat to medium and cook meat until done. Grilling times will vary according to meat thickness.

Grilling Hamburger and Sausages

Turn the grill burners on high, close lid and preheat your grill 5 minutes. After 5 minutes place the meat on the cooking grid directly above the lit burners. Cook the meat on both sides until seared. Reduce the heat to medium and move the meat away from the lit burners. Close the grill lid and cook the meat indirectly until done. Grilling times will vary according to meat thickness.

Grilling Poultry

Turn the grill burners on high, close lid and preheat your grill 2 to 3 minutes. Then raise the lid, reduce heat to medium and cook poultry directly over lit burners until done. Poultry skin is fatty so you should expect some flare-ups when using this direct method.

To minimize flare-ups, try grilling poultry using the indirect method. Place the poultry on one side of the grill with the opposing burners on medium heat, and lower the grill lid. Grilling times will vary based on the size of your poultry.

Grilling Pork

Turn burners on high and preheat your grill 5 minutes with the lid down. Raise lid, place pork on cooking grid and cook until seared. Reduce heat to medium and cook until done. Grilling times will vary according to meat thickness.

Cut of Meat

T-bone steak
Sirloin steak
Beef spare ribs
Porter house steak
New York strip steak

Hamburgers
Sausages

Chicken breast
(cook with bone down)
Chicken wings
Drumsticks

Whole bird
(cook with breast up)

Pork spare ribs
Chops
Loins
Cutlets

Approximate Cooking Times

Rare: 4-8 minutes
Medium: 10-14 minutes
Well done: 15-20 minutes

Rare: 4-6 minutes
Medium: 8-10 minutes
Well done: 10-15 minutes

Direct method:
approximately 15 minutes

Indirect method:
up to 30 minutes

Indirect method:
approximately 1 hour

Rare: 4-8 minutes
Medium: 10-14 minutes
Well done: 15-20 minutes

Guide to Grilling Fish and Seafood

Whole Fish and Whole Fillets

Preheat your grill on HIGH for 2-3 minutes with the lid down. Raise lid and turn burners to medium heat. Place fish (skin down) on grill and cook over direct heat until done. Use cooking time as a guide or until fish is opaque but still moist.

Smaller Fish Fillets and Cubes

Follow the directions from above, using approximate cooking times shown at right. Place a small piece of aluminum foil on the cooking grids if the fish pieces are small enough to drop between the cooking grids.

Cut of Meat

Whole fish
Whole fish fillets

Approximate Cooking Times

10 - 12 minutes per pound or until fish is opaque

Fish fillets
Boneless cubes

4 - 5 minutes each side or until fish is opaque

Guide to Grilling Vegetables and Fruit

Prepare your fruit or vegetables and brush with butter or basting sauce if desired. To cook **indirectly**, the food should be placed on the left or right side of your grill with the burner lit on the opposite side. Or place your food on the warming rack mounted inside your grill lid and light the outer grill burners. Either way, **indirect cooking must be done with the lid down.**

In some instances, you may want to grill vegetables and fruit **directly** over the heat, using the supplied cooking grids or an optional griddle. Foods that work best with direct heat are relatively soft and require a short cooking time; mushrooms, zucchini, tomatoes and skewered fruit such as apricots, peaches, pineapple, strawberries and kiwis. Remember the **grill lid must remain up when cooking directly.**

Grilling times using the indirect method with the hood down will be similar to those for your kitchen oven. For very firm vegetables—particularly potatoes and yams, we recommend that you partially boil until almost cooked, before placing them on the grill.

Cooking times for foods prepared with the direct method will be much shorter mainly because of the softness of the food. Timing will be comparable to normal pan frying or grilling.

ROASTING TECHNIQUES

Roasting is very easy with your Kenmore Elite gas grill. It leaves you plenty of time to relax with family and friends and saves you the hours required to clean a dirty kitchen oven. Roasting is suitable for prime, tender cuts of meat, poultry and game, many whole fish and some vegetables.

Preparing to Roast

Roasting uses the **indirect cooking** method. Therefore, the food should be placed on the left or right side of your grill with the burner lit on the opposite side. Place your meat inside an optional roasting rack and cooking pan that allows you to collect juices for making gravy. You can also use the supplied cooking grid with an aluminum drip pan underneath. Either way, indirect cooking requires the lid of your grill to be closed.

Preheating your grill is not required for slow cooking methods such as roasting. If you do choose to preheat your grill before roasting, turn the burners on high and close lid for approximately 2-3 minutes.

Food preparation

Trim meat of excess fat. Truss meat and poultry with cooking string to retain shape if desired. Bacon strips can be used to cover the outside surface of lean meat and poultry to help prevent it from drying out. Another method for keeping food moist during roasting is to put water in a cooking pan, then cover the food (and roasting rack) with foil. The foil should be removed for the first or the last part of the cooking time to ensure proper browning.

Tips for roasting

Except when roasting with water in the roasting pan, the juices that collect in the pan can be used as the base for a tasty sauce or gravy. Place a cooking pan directly over the heat, add extra butter if needed, then add several spoonfuls of flour to thicken sauce. Finally, add sufficient chicken or beef stock to obtain the desired consistency.

Once the meat is cooked, remove it from your grill and cover with a piece of foil. Allow it to stand for 10-15 minutes which allows the juices to settle. This will make carving easier and ensure a tender juicy roast.

Guide to Slow Roasting Beef, Lamb, Veal or Pork

Type of Food	How Cooked	Approximate Cooking Times
Beef	Rare	18 minutes per pound
	Medium	23 minutes per pound
	Well done	27 minutes per pound
Lamb	Medium	18 minutes per pound
	Well done	23 minutes per pound
Veal		27 minutes per pound
Pork		30-33 minutes per pound
Chicken		20-25 minutes per pound
Duck		25 minutes per pound
Fish		10 minutes per pound
Turkey, under 16 pounds		20-25 per pound + 30 minutes
Turkey, over 16 pounds		18-23 per pound + 15 minutes

SMOKING TECHNIQUES

Smoking gives food a distinctive, delicious flavor. This surprisingly quick and versatile cooking method expands the creative chef's menu with endless new and innovative ways to prepare popular barbecue dishes.

Preparing to Smoke

All you need for smoking on your Kenmore Elite gas grill is a cooking pan and roasting rack. First, line the inside of the pan with foil. The smoking agent, either pure wood chips or smoking mix, is sprinkled over the foil. Dried herbs and spices may also be added to produce different flavors. Place the cooking pan directly over the burner. The direct heat will eventually produce smoke and season the food. Elevate your food above the cooking pan with a roasting rack or baking rack.

Tips for Smoking

You can reduce the strength of the smoke flavor by only smoking for half or three quarters of the cooking time, then roast your food until done. The heat required for smoking is normally low to medium.

Foods naturally high in oils lend themselves well to smoking, while drier foods benefit from a marinade. Red meats, poultry, game, fish and seafood can all be smoked easily in your new grill. You can also rub the food with herbs, spices or flavored oils. An enormous array of foods can be smoked in your Kenmore Elite gas grill to produce stunning results with very little effort. Here are a few suggestions:

- **Tuna steaks**, marinated in Asian flavors of sesame oil, soy sauce and sherry.
- **Pork fillets**, rubbed with ginger, orange rind and brushed with maple syrup.
- **Mussels**, brushed with lemon rind and chili oil.
- **Lamb cutlets**, marinated in virgin olive oil, lemon, oregano and black pepper. The same marinade can be used for a whole leg or rack of lamb.

STIR-FRYING TECHNIQUES

This method of cooking is popular around the world and can be easily accomplished outdoors on your Kenmore Elite gas grill. It's a quick and healthful way of preparing a complete meal using meat, poultry or seafood in infinite combinations with other interesting ingredients like vegetables, rice or noodles.

Preparing to Stir-fry

Although it is possible to stir fry in other dishes, the wok is your best tool. Its high sides enable the cook to stir food without spillage. Its construction allows you to cook quickly at high temperatures, with instant control of heat which is essential for successful stir frying.

Food preparation

Slice meat and poultry into long thin strips and cube fish fillets. Remove all fat from meat and poultry and cut large vegetables into even slices or cubes.

Marinate foods for extra flavor and tenderness. Marinating times will vary for red meat, fish and or various cuts. Less tender cuts of meat should be marinated longer. Remember to always chill marinating food in the refrigerator prior to cooking.

Stir-fry meats, poultry or fish first. Next, add hard vegetables like carrots. Then continue with softer vegetables like snowpeas and peppers. To ensure even cooking, continually stir and toss the food in the wok using a wooden spoon or spatula.

Tips for Stir-frying

Place the wok directly over a high heat on your grill. Add only a small amount of food at a time to ensure fast cooking and also to allow the wok to reheat between ingredients.

- **Chicken**, boneless chicken pieces—especially sliced breasts
- **Fish**, sliced fillets of firm fish, assorted seafood such as prawns, scallops and calamari
- **Pork**, sliced fillets, diced or minced pork, sliced leg steak, sliced chops
- **Beef**, sliced fillet, rib-eye, round, rump, sirloin
- **Lamb**, sliced fillet, round, loin

DEEP-FRYING TECHNIQUES

A wide variety of foods can be deep-fried outdoors on your grill, from potatoes, to seafood and chicken. Deep-frying uses a large portion of oil, preferably saturated. The outdoor location is ideal for deep-frying as smoke, grease and smells reach for the sky—not the ceiling of your kitchen.

Preparing to Deep-fry

Deep-fry on your grill using a cooking pan or wok, over direct heat with the grill lid raised.

Fill the cooking pan no more than half full of vegetable or corn oil. Start with low heat, then raise the heat gradually. Check the temperature of the oil carefully with a frying thermometer or test with a cube of bread. The cube of bread should brown in about 30 seconds for most cooking needs. A temperature between 350 and 400 degrees is optimal for preparing the majority of deep-fried foods.

Food Preparation

Foods being deep-fried taste better when coated with either batter or breadcrumbs to add flavor and prevent moisture from escaping.

Tips for Deep-frying

Slowly lower foods into the hot oil using a wire scoop or stainless steel tongs. Add only a small quantity of food to the oil, allow it to cook, then repeat with another small quantity. This ensures the oil doesn't drop in temperature. Once the food is cooked, remove it carefully and drain onto a paper towel. Turn the heat off as soon as you have finished deep-frying and allow the pan to cool. When the oil is cool, remove all remnants of fried foods by straining it through a fine metal sieve. Once the oil is quite cool, store it in a clean bottle for future use.

COOKING ON THE WARMING RACK

Vegetables are generally easy to cook on the grill. The warming rack makes it convenient because you can still use the main cooking area while the vegetables are suspended from above.

Pre-cook hard vegetables by briefly boiling or microwaving them before cooking on the grill. Wrap vegetables in a double thickness of foil to protect them while cooking on the grill. Then, remove the foil if desired, 10-15 minutes before the end of cooking, brush vegetables with butter or oil and finish cooking.

The warming rack can be used for purposes other than just the obvious. Consider using it for warming French bread, garlic bread, croissants or even bagels. A small whole fish wrapped in foil also cooks well in the warming rack. Parcels of seafood such as scallops, prawns and sliced fish fillets prepared in a sauce and portioned into small foil wraps cooks well this way, too.

ROTISSERIE TECHNIQUES

Rotisserie cooking produces foods that are moist, flavorful and attractive. Although the rotisserie is most commonly used for cooking meat or poultry, nearly anything can be used if prepared properly.

Balancing the Food

In rotisserie cooking, balancing the food is of utmost importance. The rotisserie must turn evenly or the stopping and starting action will cause the food to cook unevenly and possibly burn the heavier side.

The easiest foods to balance are those of uniform shape and texture. To test if the food is balanced correctly when secured, place the ends of the rotisserie spit loosely in the palms of your hands. If there is no tendency to roll, give the spit a quarter turn. If it is still stable, give it a final quarter turn. It should rest without turning in each of these positions. It can then be attached to your grill.

Food Preparation

When preparing poultry, truss the birds tightly so that wings and drumsticks are close to the body of the bird. The cavity of the bird may be stuffed prior to this if you wish. Pull the neck skin down and, using a small skewer, fix it to the back of the bird. Push the rotisserie spit through lengthwise, catching the bird in the fork of the wishbone. Center the bird and tighten with the holding forks. Test the balance as described above.

A rolled piece of meat requires the rotisserie skewer to be inserted through the center of the length of meat, then secured and balanced.

For meats that contain bones, it is best to secure the rotisserie skewer diagonally through the meaty sections. If protruding bones or wings brown too quickly, cover with pieces of foil.

Tips for Rotisserie Cooking

When rotisserie cooking, the majority of heat will come from an indirect source. In other words, the burners at each end of the grill are lit and the food is placed centrally on the rotisserie, with no direct heat source underneath. To catch any drips from the rotisserie food it will be necessary to remove the cooking grids and then place a drip pan directly under the food. These drippings can be used to make gravies and other sauces to accompany the cooked meats. Place the lid down over the food when you start to cook.

The cooking times on a rotisserie will be approximately the same as for oven cooking.

BAKING TECHNIQUES

Certainly not a method of cooking usually associated with the barbecue grill, baking can be easily done on your Kenmore Elite gas grill. There is no limit to the recipes you can bake on your grill. From casseroles and cornbread to delicious deserts like fondue fruit skewers or crumb cake, it's as easy as baking in the kitchen.

Preparing to Bake

To bake in your new grill you'll need a baking dish or cast-iron cooking pan, and a pair of insulated cooking mitts. If the cooking pan is cast-iron be sure to season the pan before use.

Preheat your grill 3-5 minutes, then lower heat to achieve the baking temperature desired. Baking uses the **indirect cooking** method. Therefore, your cooking pan should be placed on the left or right side of your grill with the burner lit on the opposite side.

Tips for Baking

Prepare your favorite recipe as you would in the kitchen. Foods cooked in the grill for long periods of time should always be covered in aluminum foil to retain moisture. You will need to stir the food several times as it bakes, and add additional liquid if required.

Watch the temperature, and adjust to cook according to your recipe directions.

Guide to Baking

Oven Temperature

Slow 300° - 340° F

Moderate 355° - 390° F

High 410° - 480° F

Recommended Grill Setting

Both outside burners on low

One outside burner on high, and the other outside burner on low

Both outside burners on high

Recipes

ONION BURGERS

A honey and mustard sauce glazes the onion slices as they cook alongside these delicious burgers. For optimal sweetness, select Vidalia or Walla Walla onions. **Makes 4 open face burgers.**

Ingredients

- 2 large sweet onions, sliced (12 to 16 ounces)
- 2 tablespoons margarine or melted butter
- 2 teaspoons dry mustard
- 2 teaspoons honey
- 1 pound lean ground beef
- 1/4 teaspoon salt
- 1/8 teaspoon pepper
- 4 slices Texas toast
- 4 lettuce leaves
- 4 tomato slices

Preparing Onions

Place onions in a cooking pan or on a small piece of aluminum foil. Combine melted margarine, mustard and honey, then drizzle over onions. Cover pan with lid or fold up edges of foil and seal with double fold to completely enclose onions—leaving space for steam to build. Place pan or foil packet on grill directly over medium heat for 15 minutes with the grill hood up.

Preparing Burgers

While onions are cooking, combine ground beef, salt and pepper in a medium bowl and mix well. Shape mixture into four 3/4 inch burger patties and add to grill, directly over heat. Grill burgers along with onions for about 5 minutes, then turn burgers. Grill for 8 to 10 minutes more or until no pink remains in meat, and onions are tender. To serve, toast both sides of Texas toast on grill. Then top each slice of Texas toast with a burger, lettuce, tomato and onion. Sprinkle with pepper if desired.

DOUBLE SALSABURGERS

A fresh tomato salsa flavors the beef mixture for a zesty tasting burger. The salsa also serves as a colorful topping. **Makes 6 burger patties.**

Ingredients

- 1 large tomato, seeded and finely chopped
- 1/2 cup finely chopped green pepper
- 1/4 cup finely chopped red onion
- 2 finely chopped, seeded jalapeno peppers
- 1 garlic clove, minced
- 1 tablespoon snipped cilantro

- 1/4 teaspoon salt
- 1 1/2 pounds lean ground beef
- 2 cups shredded lettuce
- 1/3 cup finely shredded cheddar cheese
- 1/4 cup dairy sour cream and /or guacamole

Preparing the Salsa

Combine tomato, green pepper, onion, jalapeno peppers, garlic, cilantro and salt in a bowl. Set aside 2 tablespoons of salsa. Cover and chill remaining salsa until serving time.

Preparing Burgers

In another bowl, combine ground beef with 2 tablespoons of reserved salsa, mix well. Shape mixture into six 1/2 inch thick burgers and place on the grill directly over medium heat with hood up. Grill for 13 to 15 minutes or until no pink remains. Turn burgers once, halfway through grilling time. Arrange the shredded lettuce on individual plates. Top lettuce with a burger, cheddar cheese and salsa. Serve with sour cream and/or guacamole.

CHICAGO STYLE HOT DOGS

Serve these hot dogs "Chicago-style" with pickled peppers! **Makes 4 servings.**

Ingredients

- 1/3 cup ketchup
- 1/4 cup chopped pickled peppers
- 2 tablespoons pickle relish
- 2 tablespoons chopped onion
- 1/4 teaspoon poppy seed
- 4 fully cooked 4-ounce jumbo hot dogs
- 4 hot dog buns

Preparing the Relish

Combine ketchup, chopped pickled peppers, relish, onion and poppy seed in a small bowl, then set aside.

Preparing Hot Dogs

Place hot dogs on grill directly over medium heat 5 to 8 minutes with the lid up. Turn hot dogs and brush with some of the relish mixture. Grill hot dogs 6 to 8 minutes more or until thoroughly cooked.

To Serve

Toast inner sides of hot dog buns on grill. Serve hot dogs inside buns and top with remaining relish mixture.

RIB EYE STEAKS WITH GRILLED GARLIC

As they cook, the garlic cloves mellow in flavor, making a delicious sauce for any grilled meat. And for an appetizer, spread the softened cloves over toasted slices of french bread! **Makes 4 servings.**

Ingredients

- 1 whole head of garlic
- 2 tablespoons olive oil or cooking oil
- 1 tablespoon snipped fresh basil, or 1/2 teaspoon dried basil, crushed
- 1 tablespoon snipped fresh rosemary or 1/2 teaspoon dried rosemary, crushed
- 2 twelve-oz. boneless rib eye steaks

Preparing the Garlic

Use a cooking pan or tear off a 24x18-inch piece of aluminum foil and fold long length in half, then trim to make a 12-inch square. Remove the outer layer of garlic head, then cut off and discard the top 1/2-inch of garlic head to expose the garlic cloves. Place garlic head in center of a cooking pan or in center of foil with all sides of the foil folded up around the garlic to form a cup. Drizzle garlic with oil and sprinkle with basil and rosemary. Cover pan or twist the ends of the foil to completely enclose the garlic.

Preparing Steaks

Place steaks and the garlic pack on grill directly over medium heat and cook about 7 minutes with the lid up. Turn steaks and grill for 5 to 8 minutes more, or until cooked to taste. Then remove steaks and place on platter. Remove garlic and drizzle its juices over your steak. Remove the softened garlic cloves and spread over your steak. Season with salt and pepper as desired and cut into serving-size pieces.

HERB-PEPPER SIRLOIN STEAK

The hearty beef flavor is complemented with a delicious herb coating! **Makes 6 servings.**

Ingredients

- 2 tablespoons ketchup
- 1/2 teaspoon coarsely ground pepper
- 1 1/2 teaspoons snipped fresh rosemary or 1/2 teaspoon dried rosemary, crushed
- 1 1/2 teaspoons snipped fresh basil or 1/2 teaspoon dried basil, crushed
- 1/8 teaspoon garlic powder
- 1 1 1/2-pound boneless beef sirloin steak, cut 1-inch thick

Preparation

Combine ketchup, pepper, rosemary, basil and garlic powder. Coat both sides of steak with mixture. Grill steak with hood up, directly over medium heat for 6 minutes. Turn steak and grill for 8 to 12 minutes more or until cooked as desired. Cut into serving size pieces.

BARBECUED RIBS

Serve this tangy barbecue classic with corn-on-the-cob, green salad, potato salad or coleslaw! **Makes 4 servings.**

Ingredients

- 2 pounds American style pork spareribs
- 1/2 cup barbecue sauce
- 1/2 cup tomato sauce
- 2 cloves garlic, crushed
- juice of 1 lemon
- few drops of tobasco sauce

Preparation

Place ribs into a large glass or ceramic dish. Combine remaining ingredients and pour over the ribs. Refrigerate for several hours.

Preheat your grill 3 minutes and place the ribs on cooking grid. Cook indirectly, over a low to medium heat until cooked. During the last few minutes of cooking you can cook the ribs over a direct fire for added barbecue flavor and texture.

MARINATED TUNA STEAK

Experiment with unique dishes, like this tuna steak recipe boasting a delicious wine marinade! **Makes 4 servings.**

Ingredients

- 4 6-ounce fresh or frozen tuna steaks cut 1 inch thick. Thaw fish if frozen
- 1/3 cup dry white wine
- 1 tablespoon lemon juice
- 1 tablespoon olive oil or cooking oil
- 1 clove garlic, minced
- 2 teaspoons snipped fresh rosemary, crushed, or 1/2 teaspoon dried rosemary, crushed
- 1 teaspoon snipped fresh oregano, crushed, or 1/4 teaspoon dried oregano, crushed
- 1/4 teaspoon salt

Preparation

Combine wine, oil, garlic, rosemary, oregano and salt. Place tuna steak in plastic bag and into shallow dish, add marinade then seal bag. Rotate bag to coat fish well then chill for up to 2 hours, turning fish once.

Remove fish from bag and discard marinade. Place a cooking pan with baking rack or roasting rack into center of grill with outer burners on medium heat. Cook tuna steak on top of rack with lid down for 8 to 12 minutes or until fish begins to flake easily. Turn fish once during cooking. When cooked, remove fish from grill and serve.

MUSTARD-GLAZED HALIBUT STEAKS

A simple sauce of melted margarine, lemon juice, Dijon-style mustard and basil adds a scintillating note to these sizzling fish steaks! **Makes 4 servings.**

Ingredients

- 4 6-ounce fresh or frozen halibut steaks, cut 1 inch thick
- 2 tablespoons margarine or butter
- 2 tablespoons lemon juice
- 1 tablespoon Dijon-style mustard
- 2 teaspoons snipped fresh basil or 1/2 teaspoons dried basil, crushed

Preparation

Combine thawed fish, margarine or butter, lemon juice, mustard and basil into a cooking pan or aluminum foil rectangle, and cook directly over low flame until melted. Brush mixture over both sides of halibut fish steaks. Pour balance of mixture into small bowl.

Place clean cooking pan or foil on center of grill with both outer burners on medium. Place fish on grill and close lid. Cook indirectly for 8 to 12 minutes or just until fish begins to flake easily, turning once and brushing as needed with remaining mixture.

ALMOND COATED TROUT

This delicious recipe is unique and easy to prepare on your Kenmore Elite gas grill. **Makes 4 servings.**

Ingredients

- 2 trout
- 1/2 cup all purpose flour
- 1 egg, lightly beaten
- 1 cup sliced almonds
- 1/3 cup parmesan cheese, grated
- olive or peanut oil for frying

Preparation

Remove the head and tail from trout and fillet all bones. Cut each fish in half to form 4 long fillets. Coat fish in flour, dip in egg and roll in almonds. Refrigerate for 1 hour.

Fill a cast-iron pan with 1 to 2 inches of oil, and place over high heat. Cook trout until golden brown. Drain oil, sprinkle trout with parmesan cheese and serve right from the grill.

SOUTHWEST CHICKEN BREASTS

This popular recipe can also be a grilled chicken salad! Slice chicken into small strips and place them on top of shredded lettuce with avocado dressing and top with cheese! **Makes 6 servings.**

Ingredients

- 1/4 cup dry white wine
- 2 tablespoons olive oil or cooking oil
- 2 teaspoons snipped fresh tarragon or 1/4 teaspoon dried tarragon, crushed
- 1/4 teaspoon salt
- 6 skinless, boneless chicken breast halves
- 2 avocados, pitted, peeled and chopped
- 1 tomato, chopped
- 1 clove garlic, minced
- 2 tablespoons finely chopped seeded green chili peppers of your choice
- 2 green onions, finely chopped
- 1 tablespoon snipped fresh cilantro
- 1 tablespoon honey
- 1 tablespoon lemon juice

Preparing the Chicken

Combine wine, oil, tarragon and salt. Rinse chicken and dry with paper towels. Place chicken in plastic bag and into shallow dish—then add marinade and seal bag. Rotate chicken to coat well and chill up to 24 hours, turning bag occasionally.

Preparing the Avocado Dressing

Combine avocados, tomato, garlic, chili peppers, onions, cilantro, honey and lemon juice. Toss well then cover and chill up to 2 hours.

Grilling the Chicken

Remove the chicken from plastic bag and reserve the marinade. Grill chicken directly over medium heat with lid up for 5 minutes. Turn chicken and brush with marinade, then grill for 5-10 minutes more or until chicken is no longer pink. Serve with side of avocado dressing.

BARBECUED CHICKEN

Another backyard favorite, this recipe includes an easy to make, sweet and spicy sauce.

Makes 4 servings.

Ingredients

- 1/2 cup ketchup
- 1/4 cup orange marmalade
- 1 tablespoon vinegar
- 1/2 teaspoon celery seed
- 1/2 teaspoon chili powder
- 1/4 to 1/2 teaspoon bottled hot pepper sauce
- 1 2 1/2 to 3 pound broiler-fryer chicken, pre-cut

Preparing the Sauce

Combine ketchup, marmalade, vinegar, celery seed, chili powder and hot pepper sauce in a cooking pan, and cook directly over a low to medium heat. Leave the cooked sauce in the pan and remove from heat until chicken is prepared.

Preparing the Chicken

Wash chicken and dry with paper towels. Turn outside burners on medium and place pre-cut chicken pieces (bone side down) in center of grill. Close lid and cook indirectly for 1 hour or until chicken is no longer pink. Brush occasionally with sauce. Remove chicken from grill once cooked, then place cooking pan with sauce into center of grill and reheat. Pour warmed sauce over chicken and serve.

TRADITIONAL HOLIDAY TURKEY

Imagine everyone's surprise when you serve your next holiday turkey—complete with dressing—delicious and tender straight from the grill! **Serves 8 - 10**

Ingredients for Turkey

- 8 - 10 pound whole turkey
- 4 ounces butter, softened
- 2 tablespoons chopped thyme
- 2 tablespoons lemon juice
- 2 teaspoons grated lemon rind

Ingredients for Dressing

- 2 ounces butter
- 2 onions, finely chopped
- 8 ounces bacon, chopped
- 2 tablespoons port wine
- 1/4 cup red wine
- 2 chicken stock cubes
- 4 ounces chopped cashews, hazelnuts or pecans
- 1/2 cup chopped celery
- 1/2 cup chopped carrot
- 1 - 1 1/2 cups fresh white breadcrumbs
- 1 egg, lightly beaten
- salt and pepper to taste

Preparing the Dressing

Prepare dressing in a cooking pan directly over medium heat. Melt butter, add onions and bacon then saute 3 minutes. Add port, red wine and stock cubes and bring to a boil. Cook 2 minutes. Remove pan to allow ingredients to cool. Add remaining ingredients and mix.

Preparing the Turkey

Although not required, you may want to preheat your grill 3 minutes.

Wash inside of turkey and dry with paper towels. Pack breadcrumb seasoning into the turkey cavity. Combine the butter, thyme, lemon juice and rind together in a bowl. Using turkey baster, insert butter mixture under skin covering the turkey breast.

Truss the turkey with string and place it on a baking pan or roasting rack that rests into a cooking pan. Remove the cooking grids from your grill if necessary, then place the cooking pan and turkey in the center of your grill. Turn one outside burner to low, the other to medium, and close lid. Cook indirectly for 3 1/2 to 4 hours or until cooked. Halfway through cooking time you may alternate burner temperatures so that the turkey browns evenly. Once cooked, remove dressing from cooked turkey, slice and serve.

PIZZA ON THE GRILL

You may never want to call out for pizza again! Follow this pizza dough recipe, or purchase ready-made pizza dough found in your grocers refrigerated section—next to the biscuits. Slice and serve directly from the grill. **Serves 6 - 8**

Ingredients

- 1 1/2 teaspoons dried yeast
- 1 cup lukewarm water
- 1/2 teaspoon sugar
- 3 tablespoons olive oil
- 3 cups all purpose flour
- 1/4 cup tomato paste or Italian tomato sauce
- 6 ounces sliced pepperoni
- 1 red pepper, roasted and sliced
- 3/4 cup pitted black olives
- 8 ounces grated mozzarella cheese

It's easy to customize this recipe with toppings to suit your family's taste. For spicier crust, lightly rub the dough with olive oil then spice with pepper and garlic salt before spreading your tomato sauce.

Preparing the Pizza Dough

Combine yeast, water and sugar together and let stand in a warm place until mixture starts to foam. Add this yeast mixture to flour and oil and combine to form your pizza dough. Knead on a lightly floured surface until smooth and elastic. Cover and stand in a warm place until doubled in size. Knock back dough and roll out to a rectangle the size of your cooking pan or baking dish. Place dough into a lightly oiled pan.

If you purchased a ready-made pizza dough, simply open can and roll dough into a lightly oiled cooking pan.

Preparing the Pizza

Spread tomato paste or Italian tomato sauce on top of your pizza dough. Top with pepperoni, red peppers, olives, and lastly, mozzarella cheese. Or if you prefer, you may place cheese first with toppings on last.

Place cooking pan in center of grill and cook indirectly, with one outside burner on high and the other on low, for approximately 20 minutes or until bottom of crust is light brown. Lastly, raise the lid and finish cooking pizza by turning burner under the cooking pan on high for about 2 minutes. This will insure the center of pizza gets brown. Then turn off heat, slice and serve directly from pan.

FRESH VEGETABLE STIR-FRY

Take a trip to the Orient with this easy, and healthy vegetable recipe. **Makes 4 - 6 servings.**

Ingredients

- 2 tablespoons oil
- 1 onion, cut into wedges
- 1 carrot, thinly sliced
- 2 cups broccoli, cut into small flowerets
- 1 red pepper, sliced
- 2 sticks celery, thinly sliced
- 1 cup snow peas
- 1/2 cup chicken broth

Preparation

Heat oil in a wok or saute pan, directly over a high heat. Add onion and cook 1 minute. Add carrot and broccoli and stir-fry 2 minutes, then add red pepper, celery and snow peas and continue cooking 1 minute more. Add chicken broth and toss vegetables until cooked to desired doneness.

ONION BLOSSOMS

Great served as a snack, or to dress up barbecued meats, poultry or fish. **Makes 4 servings.**

Ingredients

- 4 medium sweet onions (4-5 ounces each)
- 1 tablespoons margarine or butter, melted
- 1 teaspoon Dijon-style mustard
- 1/8 teaspoon hot pepper sauce
- 1 tablespoon brown sugar
- 1 pepper (optional)

Preparation

Peel onions, then cut almost completely through each onion, forming 8 wedges. Onion will be loose, but still be intact. Prepare four 12-inch squares of aluminum foil. Place one onion in the center of each foil square.

Stir margarine (or butter) with hot pepper sauce and drizzle over onions. Sprinkle with brown sugar. Then bring up two sides of foil square and double fold. Bring remaining corners up and completely enclose—leaving enough space for steam to build.

Place wrapped onion blossoms on grill, directly over medium heat. Close lid and cook 15 to 25 minutes or until onions are nearly tender. Make a 2-inch opening at the top of each onion wrapping, then close lid and cook 5 to 10 minutes more, or until onions are lightly browned. Sprinkle with pepper if desired and serve warm.

GRILLED POTATO SKINS

Serve these crispy potatoes as a snack or side dish. We've included microwave instructions for a timesaving short cut. **Makes 12 servings.**

Ingredients

- 6 baking potatoes (about 8 ounces each)
- 3 tablespoons margarine or butter, melted
- 1/2 cup picante sauce
- 1 cup shredded cheddar cheese (4 ounces)
- 3 slices bacon, crisp-cooked and crumbled or use prepackaged bacon bits
- 1 chopped tomato (optional)
- 1 diced green onion (optional)
- 1/2 cup sour cream (optional)

Preparation

Puncture clean potatoes with a fork, wrap in aluminum foil and place directly over low to medium heat. Close lid and cook directly for 1 hour or until center is tender. OR - Microwave clean, punctured potatoes on high for 15 to 20 minutes, or until center tender. Allow cooked potatoes to cool then unwrap and discard foil.

Cut potatoes in half - lengthwise. Scoop out potato pulp (serve separately or discard.) Be sure to leave 1/4-inch thick potato shell remaining. Brush the inside of each potato shell with melted margarine. Spoon 2 teaspoons picante sauce into each potato shell, sprinkle with cheese and top with bacon.

Place prepared potato skins on grill, directly over medium heat. Close lid and cook for 8 to 10 minutes or until potato skins are crisp. Sprinkle each potato skin with tomato and green onion and then top with sour cream, if desired.

**For in-home repair of a major appliance,
no matter who made it, no matter who sold it!**

Call 24 hours a day, 7 days a week

1-800-4-MY-HOMESM (1-800-469-4663)

Para pedir servicio o ordenar piezas:

1-888-SU-HOGARSM (1-888-784-6427)

Pour tout le service:

1-877-LE-FOYERSM (1-877-533-6937)

**For repair of carry-in products like
vacuums, lawn mowers, stereos and VCRs,
call for the nearest Sears Service Center location.**

Call 24 hours a day, 7 days a week

1-800-488-1222

**For the replacement parts and owner's manuals that
you need to "do-it-yourself," call and ask for PartsDirect.**SM

Call 6 a.m. - 11 p.m. CT, 7 days a week

1-800-4-MY-HOMESM (1-800-469-4663)

www.sears.com/partsdirect

For a Sears Service Agreement purchase or inquiry:

Call 7 a.m. - 5 p.m. CT, Monday - Saturday

1-800-827-6655

