

# SEARS

Model No.  
**919.679501**

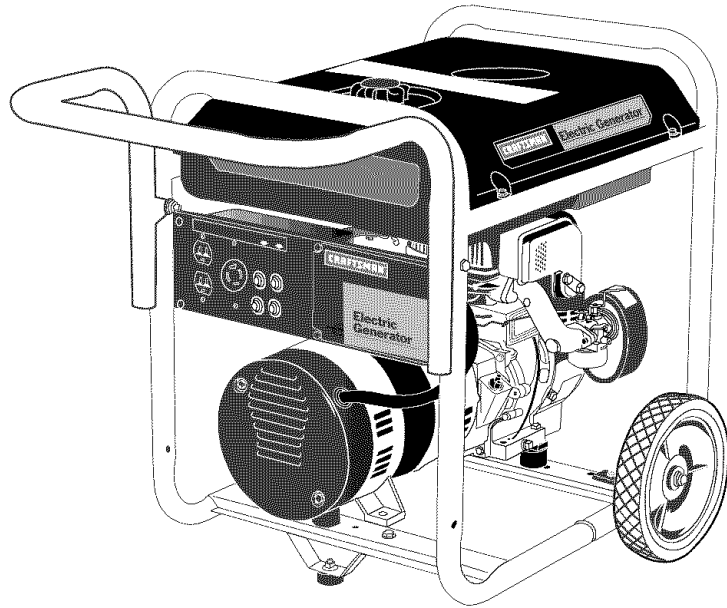

## CRAFTSMAN

**120/240 VOLT • 5000 WATT  
GENERATOR**

**IMPORTANT:**

Read the Safety Guidelines  
and All Instructions Carefully  
Before Operating

- SAFETY GUIDELINES
- ASSEMBLY
- OPERATION
- MAINTENANCE
- TROUBLESHOOTING
- REPAIR PARTS

---

**Sold by Sears Canada, Inc., Toronto, Ont. M5B2B8**

---

# TABLE OF CONTENTS

Warranty .....	2	Storage .....	17
Safety Guidelines .....	3-8	Troubleshooting Guide .....	17
Assembly .....	9-10	Generator Parts .....	18-20
Operation .....	11-14	Engine Parts .....	21-24
Maintenance .....	14-16	EPA Codes .....	25-26
Service Adjustments .....	16	How To Order Parts .....	Back Cover

DATE PURCHASED: \_\_\_\_\_

MODEL NO: \_\_\_\_\_

SERIAL NO: \_\_\_\_\_

STORE WHERE PURCHASED: \_\_\_\_\_

ADDRESS: \_\_\_\_\_

CITY: \_\_\_\_\_

TELEPHONE: \_\_\_\_\_

Record the above information about your unit so that you will be able to provide it in case of loss or theft.

HORSE POWER	10 HP
GASOLINE CAPACITY	7 GALLON
OIL CAPACITY	26 OZ.

## MAINTENANCE AGREEMENT

The Craftsman Warranty, plus a Maintenance Agreement, provide maximum value for your Sears products. Contact your nearest Sears store for details.

## CUSTOMER RESPONSIBILITIES

Read and observe the safety rules.

Follow a regular schedule in maintaining, caring for and using your generator.

Follow the instructions under "Customer Responsibilities" and "Storage" sections of this owner's manual.

## FULL ONE YEAR WARRANTY ON CRAFTSMAN GENERATORS

For one year from the date of purchase, when this Craftsman generator is maintained and operated according to the instructions in this owner's manual, Sears will repair, free of charge, any defect in material and workmanship.

If your Craftsman Generator is used for commercial or rental purposes, this warranty applies for only 90 days from the original date of purchase.

## FULL ONE YEAR WARRANTY ON CRAFTSMAN ENGINE

For one year from the date of purchase, when this Craftsman engine is maintained and operated according to the instructions in this owner's manual, Sears will repair, free of charge, any defect in material and workmanship.

If your Craftsman engine is used for commercial or rental purposes, this warranty applies only for 90 days from the date of purchase. This warranty does not cover: Expendable items such as spark plugs and air filters, which become worn during normal use.

Repairs necessary because of operator abuse or negligence, including damage resulting from no oil being supplied to the engine or failure to maintain the equipment according to the instructions contained in this owner's manual, are not covered under warranty.

WARRANTY SERVICE IS AVAILABLE BY RETURNING THE GENERATOR TO THE NEAREST SEARS SERVICE CENTER. This warranty gives you specific legal rights and you may also have other rights, which vary from PROVINCE TO PROVINCE.

**Sold by Sears Canada, Inc., Toronto, Ont.**

# SAFETY GUIDELINES - DEFINITIONS

This manual contains information that is important for you to know and understand. This information relates to protecting **YOUR SAFETY** and **PREVENTING EQUIPMENT PROBLEMS**. To help you recognize this information, we use the symbols to the right. Please read the manual and pay attention to these sections.

<b>⚠ DANGER</b>	<b>⚠ CAUTION</b>
<b>DANGER</b> indicates an imminently hazardous situation which, if not avoided, will result in <u>death or serious injury</u> .	<b>CAUTION</b> indicates a potentially hazardous situation which, if not avoided, <u>may</u> result in <u>minor or moderate injury</u> .
<b>⚠ WARNING</b>	<b>CAUTION</b>
<b>WARNING</b> indicates a potentially hazardous situation which, if not avoided, <u>could</u> result in <u>death or serious injury</u> .	<b>CAUTION</b> used without the safety alert symbol indicates a potentially hazardous situation which, if not avoided, <u>may</u> result in <u>property damage</u> .

**This product is not equipped with a spark arresting muffler.** If the product will be used around flammable materials, or on land covered with materials such as agricultural crops, forest, brush, grass, or other similar items, then an approved spark arrester must be installed and is legally required in the state of California. It is a violation of California statutes section 130050 and/or sections 4442 and 4443 of the California Public Resources Code, unless the engine is equipped with a spark arrester, as defined in section 4442, and maintained in effective working order. Spark arresters are also required on some U. S. Forest service land and may also be legally required under other statutes and ordinances.

This product may contain chemicals known to the state of California to cause cancer, birth defects, or other reproductive harm. This warning is given in compliance with California Proposition 65, as detectable amounts of chemicals subject to proposition 65 may be contained in this product.

## IMPORTANT SAFETY INSTRUCTIONS

- **SAVE THESE INSTRUCTIONS** •

### ⚠ WARNING

When using this product basic precautions should always be followed including the following:

### ⚠ DANGER

#### RISK OF ELECTROCUTION AND FIRE

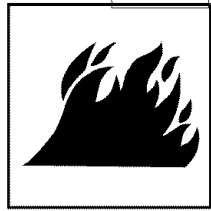
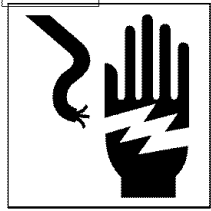

HAZARD	WHAT COULD HAPPEN	HOW TO PREVENT IT
Attempting to connect generator directly to the electrical system of any building structure.	<p>Back feeding electricity through a building's electrical system to the outside utility feed lines could endanger repair persons attempting to restore service.</p> <p>Attempting to connect to the incoming utility service could result in electrocution.</p> <p>Restoration of electrical service while the generator is connected to the incoming utility could result in a fire or serious damage if a isolator switch is not installed.</p> <p>Failure to use a double throw transfer switch when connecting to a structure's electrical system can damage appliances and <b>WILL VOID</b> the manufacturer's warranty.</p>	<p>Never backfeed electricity through a structure's electrical system.</p> <p>To connect to a structure's electrical system in a safe manner, always have a Double-Throw Transfer Switch installed by a qualified electrician and in compliance with local ordinances. <b>(When installing a Double-Throw Transfer Switch, a minimum of 10 gauge wiring must be used.)</b></p>

**READ AND UNDERSTAND ALL WARNINGS BEFORE  
ATTEMPTING TO OPERATE GENERATOR.**

**⚠ DANGER**

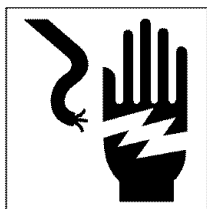

**RISK OF ELECTROCUTION AND FIRE (cont'd)**

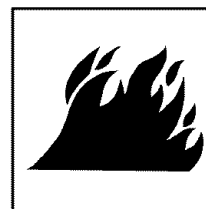

<b>HAZARD</b>	<b>WHAT COULD HAPPEN</b>	<b>HOW TO PREVENT IT</b>
Operation of generator in rain, wet, icy, or flooded conditions.	Water is an excellent conductor of electricity! Water which comes in contact with electrically charged components can transmit electricity to the frame and other surfaces, resulting in electrical shock to anyone contacting them.	Operate generator in a clean, dry, well ventilated area. Make sure hands are dry before touching unit.
Use of worn damaged, undersized or ungrounded extension cords.	<p>Contact with worn or damaged extension cords could result in electrocution.</p> <p>Use of undersize extension cords could result in overheating of the wires or attached items, resulting in fire.</p> <p>Use of ungrounded cordsets could prevent operation of circuit breakers and result in electrical shock.</p>	<p>Inspect extension cords before use and replace with new cord if required.</p> <p>Use proper size (wire gauge) cordset for application see chart in the Assembly section of this manual.</p> <p>Always use a cordset having a grounding wire with an appropriate grounding plug. DO NOT use an ungrounded plug.</p>
Placing generator on or against highly conductive surface, such as a steel walkway or metal roof.	Accidental leakage of electrical current could charge conductive surfaces in contact with the generator.	<p>Place generator on low conductivity surface such as a concrete slab.</p> <p>ALWAYS operate generator a minimum of six feet from any conductive surface.</p>
Improper connection of items to generator.	Exceeding the load capacity of the generator by attaching too many items, or items with very high load ratings to it could result in overheating of some items or their attachment wiring resulting in fire or electrical shock.	Read the load rating chart and instructions in the Wattage Calculation section. Make sure that the summation of electrical loads for all attachments does not exceed the load rating of the generator.
Operation of unit when damaged, or with guards or panels removed.	<p>Attempting to use the unit when it has been damaged, or when it is not functioning normally could result in fire or electrocution.</p> <p>Removal of guarding could expose electrically charged components and result in electrocution.</p>	<p>Do not operate generator with mechanical or electrical problem. Have unit repaired by an Authorized Service Center.</p> <p>Do not operate generator with protective guarding removed.</p>

**READ AND UNDERSTAND ALL WARNINGS BEFORE  
ATTEMPTING TO OPERATE GENERATOR.**

**⚠ WARNING  
RISK OF FIRE**

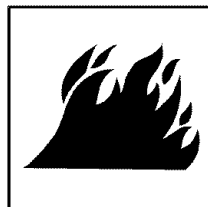

<b>HAZARD</b>	<b>WHAT COULD HAPPEN</b>	<b>HOW TO PREVENT IT</b>
Attempting to fill the fuel tank while the engine is running.	Gasoline and gasoline vapors can become ignited by coming in contact with hot components such as the muffler, engine exhaust gases, or from an electrical spark.	Turn engine off and allow it to cool before adding fuel to the tank. Equip area of operation with a fire extinguisher certified to handle gasoline or fuel fires.
Sparks, fire, hot objects	Cigarettes, sparks, fires, or other hot objects can cause gasoline or gasoline vapors to ignite.	Add fuel to tank in well ventilated area. Make sure there are no sources of ignition near the generator.
Improper storage of fuel	Improperly stored fuel could lead to accidental ignition. Fuel improperly secured could get into the hands of children or other unqualified persons.	Store fuel in a OSHA approved container designed to hold gasoline. Store container in secure location to prevent use by others.
Inadequate ventilation for generator	Materials placed against or near the generator or operating the generator in areas where the temperature exceeds 104° F. ambient (such as storage rooms or garages) can interfere with its proper ventilation features causing overheating and possible ignition of the materials or buildings.	Operate generator in a clean, dry, well ventilated area a minimum of four feet from any building, object or wall. <b>DO NOT OPERATE UNIT INDOORS OR IN ANY CONFINED AREA.</b>
Tampering with factory set engine speed settings.	Engine speed has been factory set to provide safe operation. Tampering with the engine speed adjustment could result in overheating of attachments and could cause a fire.	Never attempt to " <b>speed-up</b> " the engine to obtain more performance. Both the output voltage and frequency will be thrown out of standard by this practice, endangering attachments and the user.
Overfilling the fuel tank – fuel spillage.	Spilled fuel and its vapors can become ignited from hot surfaces or sparks.	Use care in filling the tank to avoid spilling fuel. Make sure fuel cap is secured tightly and check engine for fuel leaks before starting engine. Move generator away from refueling area or any spillage before starting engine. Allow for fuel expansion. Keep maximum fuel level ¼ inch below the tip of the fuel tank. Never refuel with the engine running.

**READ AND UNDERSTAND ALL WARNINGS BEFORE  
ATTEMPTING TO OPERATE GENERATOR.**

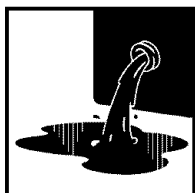

**⚠ DANGER**

**Risk of Injury and Property Damage When  
Transporting Generator**

<b>HAZARD</b>	<b>WHAT COULD HAPPEN</b>	<b>HOW TO PREVENT IT</b>
Fire, Inhalation, Damage to Vehicle Surfaces	Fuel or oil can leak or spill and could result in fire or breathing hazard, serious injury or death can result. Fuel or oil leaks will damage carpet, paint or other surfaces in vehicles or trailers.	If generator is equipped with a fuel shut-off valve, turn the valve to the off position before transporting to avoid fuel leaks. If generator is not equipped with a fuel shut-off valve, drain the fuel from tank before transporting. Transport fuel only in an OSHA approved container. Always place generator on a protective mat when transporting to protect against damage to vehicle from leaks. Remove generator from vehicle immediately upon arrival at your destination

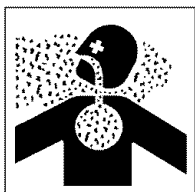

**⚠ DANGER**

**RISK OF BREATHING - INHALATION HAZARD**

<b>HAZARD</b>	<b>WHAT COULD HAPPEN</b>	<b>HOW TO PREVENT IT</b>
Gasoline engines produce toxic carbon monoxide exhaust fumes.	Breathing exhaust fumes will cause serious injury or death.	Operate generator in clean, dry, well ventilated area. Never operate unit in enclosed areas such as garages, basements, storage, sheds, or in any location occupied by humans or animals. Keep children, pets and others away from area of operating unit.

**READ AND UNDERSTAND ALL WARNINGS BEFORE  
ATTEMPTING TO OPERATE GENERATOR.**



**⚠ WARNING**

**RISK OF UNSAFE OPERATION**

<b>HAZARD</b>	<b>WHAT COULD HAPPEN</b>	<b>HOW TO PREVENT IT</b>
Operation of generator in careless manner.	All sources of energy include the potential for injury. Unsafe operation or maintenance of your generator could lead to serious injury or death to you or others.	<ul style="list-style-type: none"> <li>• Review and understand all of the operating instructions and warnings in this manual.</li> <li>• Become familiar with the operation and controls of the generator. Know how to shut it off quickly.</li> <li>• Equip area of operation with a fire extinguisher certified to handle gasoline or fuel fires.</li> <li>• Keep children or others away from the generator at all times.</li> </ul>
Operation of voltage sensitive appliances without a voltage surge protector.	Any gasoline operated household generator will incur voltage variations causing damage to voltage sensitive appliances or could result in fire.	<p>Always use a U.L. listed voltage sensitive surge protector to connect voltage sensitive appliances (TV, computer, stereo, etc.). <b>Failure to use a U.L. listed voltage surge protector will void the warranty on your generator.</b></p> <p><b>Notice:</b> A multiple outlet strip is not a surge protector make sure you use a U.L. listed voltage surge protector.</p>
Raising or suspending generators equipped with lift rings improperly	<p>Generator could fall causing serious injury or death to you or others.</p> <p>Improper raising or suspending can cause damage to the generator.</p>	<p>Always use proper connecting procedures as described in this manual when connecting cables, chains, or straps for raising or suspending generators equipped with lift rings.</p> <p>Always use cables, chains, or straps rated at 2000 lbs working load or more to raise or suspend generator.</p>
Operating generator while suspended	Generator will not operate properly and will cause damage to the generator and could cause serious injury or death to you or others.	Never operate generator while suspended or in an unlevel position. Always operate generator on a flat, level surface.

**READ AND UNDERSTAND ALL WARNINGS BEFORE  
ATTEMPTING TO OPERATE GENERATOR.**



**⚠ WARNING**  
**RISK OF HOT SURFACES**

HAZARD	WHAT COULD HAPPEN	HOW TO PREVENT IT
Contact with hot engine and generator components.	Contact with hot surfaces, such as engines exhaust components, could result in serious burns.	During operation, touch only the control surfaces of the generator. Keep children away from the generator at all times. They may not be able to recognize the hazards of this product.

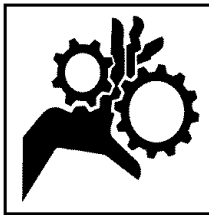

**⚠ WARNING**  
**RISK OF MOVING PARTS**

HAZARD	WHAT COULD HAPPEN	HOW TO PREVENT IT
Contact with moving parts can result in serious injury.	The generator contains parts which rotate at high speed during operation. These parts are covered by guarding to prevent injury.	Never operate generator with guarding or cover plates removed. Avoid wearing loose fitting clothing or jewelry which could be caught by moving parts.



**⚠ WARNING**  
**RISK FROM LIFTING**

HAZARD	WHAT COULD HAPPEN	HOW TO PREVENT IT
Lifting a very heavy object.	Serious injury can result from attempting to lift too heavy an object.	The generator is too heavy to be lifted by one person. Obtain assistance from others before you try to move it.



# ASSEMBLY

## CARTON CONTENTS

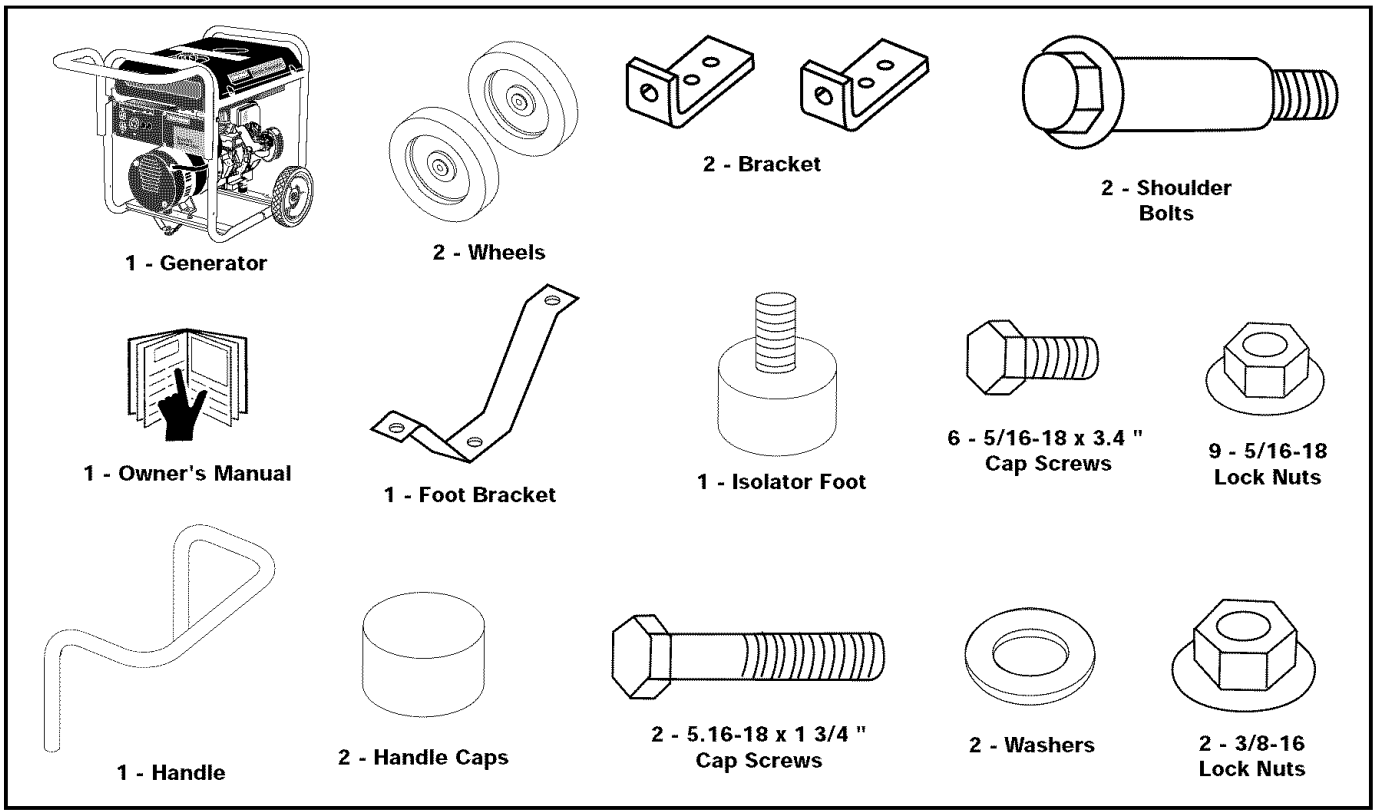

### **CAUTION**

Read owner's manual. Do not attempt to operate equipment until you have read Owner's Manual for Safety, Assembly, Operation, Maintenance, Storage Instructions.

## TOOLS NEEDED FOR ASSEMBLY

- 1- Box Cutter or Knife
- 2 - 9/16" Wrenches
- 2 - 1/2" Wrenches
- 1 - 1" thick x 1' square piece of wood

## REMOVE GENERATOR FROM CARTON

- Open carton from top.
- Cut carton along dotted lines.
- Remove all carton inserts.
- Remove generator through opening in carton.
- Using a 9/16 inch socket remove shipping block from under the generator head. Unscrew the bolt and remove the wood block. **NOTE:** It is very important that this is removed before starting your generator.

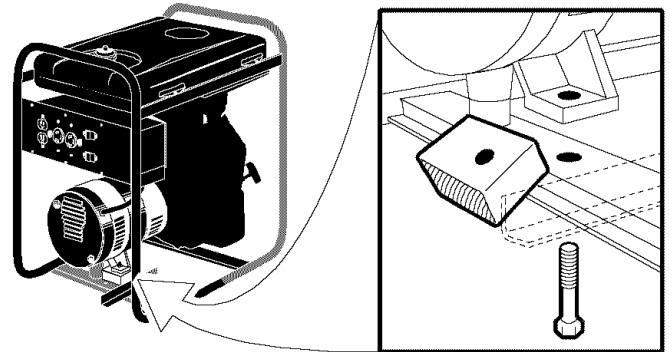

**IMPORTANT:** Before any attempt to start your generator be sure to check engine oil (See Adding Engine Oil paragraph in the Operation section on page 13 of this manual.)

## GROUNDING THE GENERATOR

A grounding lug is supplied with the generator for use when required by local electrical ordinances. Refer to article 250 of the National Electrical Code to clarify any needed grounding information. Your local electric company or a certified electrician should be able to help you with this information.

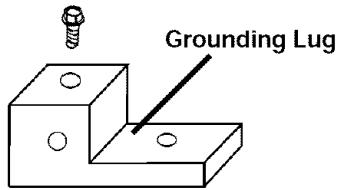

**NOTE:** Your engine is already grounded to the frame by a grounding strap.

## INSTALLING WHEEL KIT

The Craftsman Wheel Kit was designed to greatly improve the portability of your generator.

**CAUTION** Drain gas and oil before assembling the portability kit. Failure to do so will cause damage to the engine.

**NOTE:** Always follow state regulations for proper oil disposal.

- Place generator on level ground; drain all gas and oil from the engine (see engine manual for correct procedure).
- Place a 1" thick x 1' square piece of wood on the ground in front of the engine. With the help of another person, tilt the generator and rest the recoil starter on the wood. **NOTE:** This will support the gasoline engine during assembly and make assembly easier.
- Place a handle cap (7) onto each end of handle prior to installation.
- The handle should be installed on the electrical outlet end of the generator. Place one washer (12) on long cap screws (11). Align the handle brackets with the upper holes pre-drilled in the generator frame. Place mentioned screws through frame and handle brackets. Secure with lock nuts (8) and tighten.
- Locate the engine support. Place one wheel bracket (4) on top of support as shown in illustration. Align with the pre-drilled holes in support. Place 2 cap screws (9) through holes in bracket and support. Secure with 2 lock nuts (8) and tighten.
- Insert one shoulder bolt (2) into wheel (1). Insert threaded end of bolt through wheel bracket, secure with lock nut (3) and tighten. **NOTE: The wheel will not rub frame if installed properly.**

- Repeat the above steps for the opposite side.
- Insert the threaded stud of rubber foot (10) through the middle hole of the foot bracket (5). Secure with lock nut (8) and tighten.
- Locate the support under the electrical outlet end of the generator. Position foot bracket (5), with rubber foot installed, under the support and align the holes in the foot bracket (5) with the slots in the support. Place one cap screw (9) through each slot in the support and the holes in the foot bracket. Secure with the lock nuts (8) and tighten.
- Once completed, the wheel kit is ready for use.

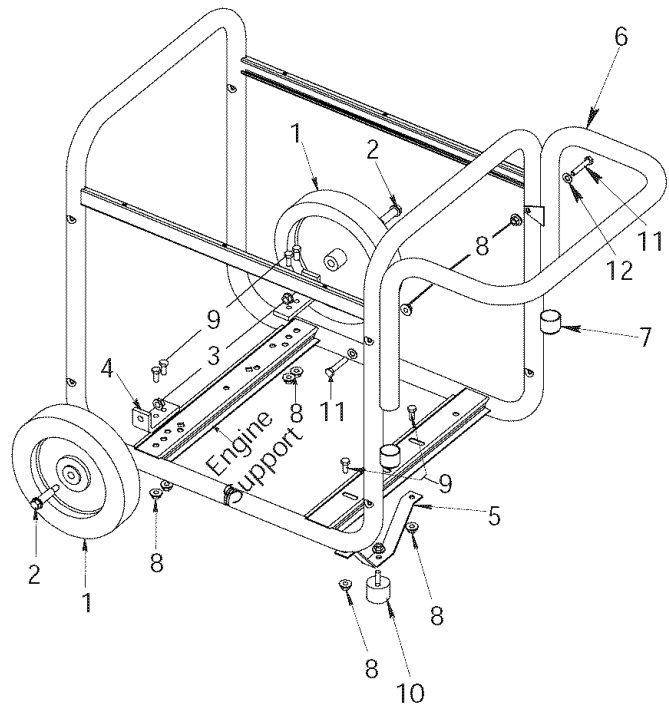

**This portability kit includes the following parts:**

<b>Key No.</b>	<b>Description</b>	<b>PART NO.</b>
1	Wheel (2 used)	AC-0014
2	Shoulder Bolt (2 used)	CAC-60
3	Lock Nut 3/8" - 16 (2 used)	SSF-8111-ZN
4	Wheel Bracket (2 used)	GS-0561
5	Foot Bracket	GS-0562
6	Handle	GS-0564
7	Handle Cap (2 used)	GS-0565
8	Lock Nut 5/16" - 18 (9 used)	SSF-8150
9	Cap Screw 5/16" - 18 x 3/4" (6 used)	SS-12-CD
10	Isolator Foot	GS-0587
11	Cap Screw 5/16-18 x 1.75" (2 used)	SSF-999-1
12	Washer (2 used)	SS-6506-CD

# OPERATION

## KNOW YOUR GENERATOR

Read this Owner's Manual and Safety Rules before operation of your Generator. Compare this illustration with your generator to familiarize yourself with the location of various controls and adjustments. Save the manual for future references.

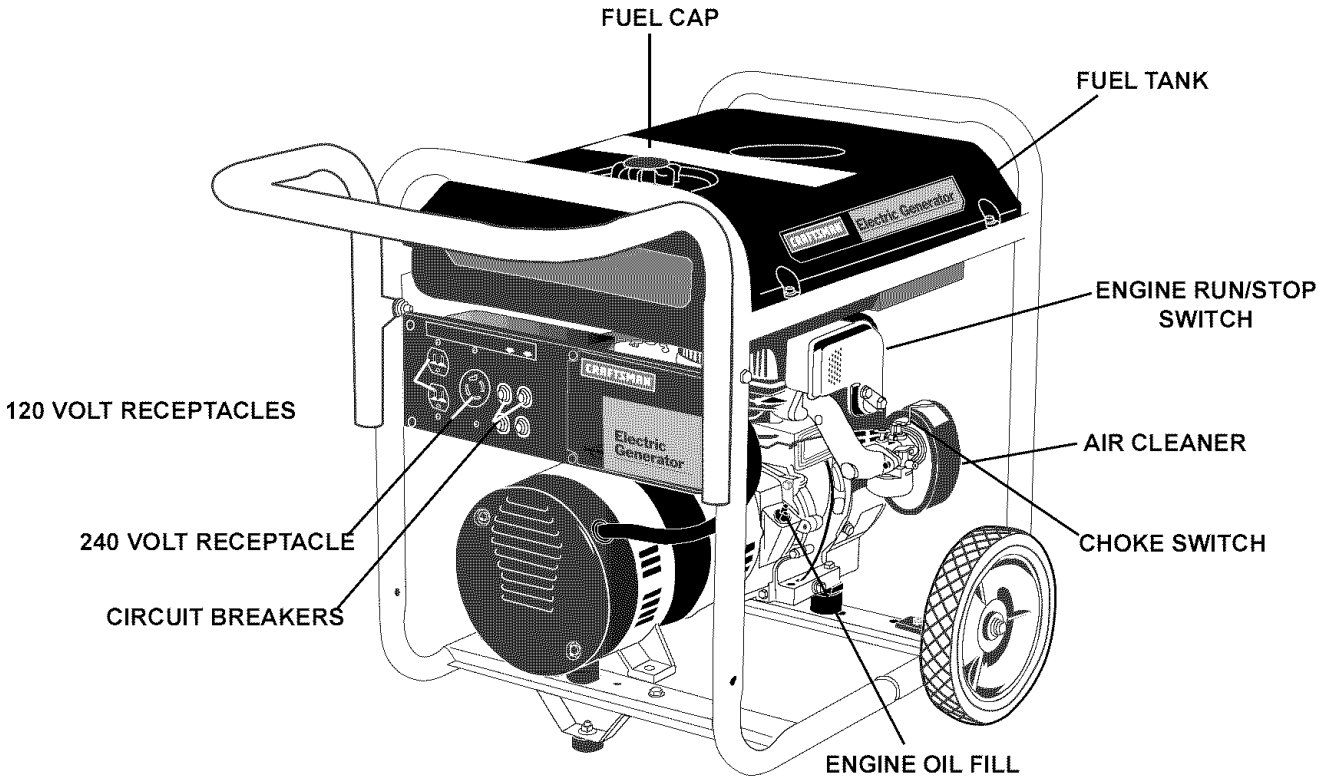

**FUEL TANK**- Capacity of 7 US gallons.

**CHOKE SWITCH**- Lever used to start cold engine.

**ENGINE RUN/STOP SWITCH**- Sets engine in starting mode for recoil starter - Stops running engine.

**ENGINE OIL FILL**- Place where engine oil is poured.

**CIRCUIT BREAKER**- Each receptacle has a circuit breaker to protect the generator from overloading.

**120 VOLT RECEPTACLES**- Used to supply 1800 watts of electrical power per receptacle or a combination of 3600 watts on the 120 side for operations. Protected by 15 amp circuit breaker.

**240 VOLT TWISTLOCK RECEPTACLE**- Used to supply 5000 watts of electrical power per receptacle for operations. Protected by 20 amp circuit breaker.

**AIR CLEANER**- Includes filter element and foam pre-cleaner that limits the amount of dirt that enters the engine.

## RECEPTACLES

Your generator is equipped with duplex 120 volt receptacles and a twistlock 240 volt receptacle.

The unit is also equipped with a 15 amp circuit breaker for the 120 volt receptacles and a 20 amp circuit breaker for the 240 volt receptacle which is provided to protect the generator against electrical overload. If the circuit breaker trips, unplug electrical load from receptacle. Let circuit breaker cool down and then push circuit breaker button to reset.

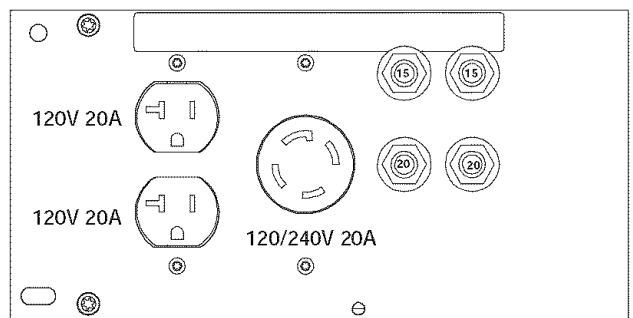

## LOW OIL SHUTDOWN

Your Craftsman generator engine is equipped with Low Oil Shutdown. Low Oil Shutdown is a safety device designed to protect your engine from damage in the event the oil level in the crankcase is low.

If while the engine is running, the oil gets low, it will automatically shut itself down and will not restart until the oil is added. If the oil is low before start-up, the generator will not start until oil is added.

**NOTE:** The Low Oil Shutdown mechanism is very sensitive. You must fill the engine to the full mark on the dipstick to inactivate this safety device.

## GENERATOR CAPACITY

Exceeding the rated capacity of your generator can result in serious damage to your generator and connected electrical devices. You should observe the following to prevent overloading the unit:

- Starting and running wattage requirements should always be calculated when matching a generator's wattage capacity to the appliance or tool.
- There are two types of electrical appliances that can be powered by your generator:
  - A. Items such as radios, light bulbs, television sets, and microwaves have a "resistive load". Starting wattage and running wattage are the same.
  - B. Items such as refrigerators, air compressors, washer, dryer, and hand tools that use an electrical motor have an "inductive load". Inductive load appliances and tools require approximately 2 to 4 times the listed wattage for **starting** the equipment. This initial load only lasts for a few seconds on start-up but is very important when figuring your total wattage to be used.

**NOTE:** Some inductive appliances and tools will list on the motor name plate, the starting and running voltage and amperage requirements. Use the following formula to convert voltage and amperage to wattage: **(Volts X Amp = Watts)**

- Always start your largest electric motor first, and then plug in other items, one at a time.

**NOTE:** On 120-volt loads the maximum starting wattage should **NOT** exceed one half of the rated generator wattage. Example: a 5000 rated wattage generator = 2500 maximum starting wattage.

The guide is provided to assist you in determining the appliances and tools that can be ran with the wattage capacity of your generator.

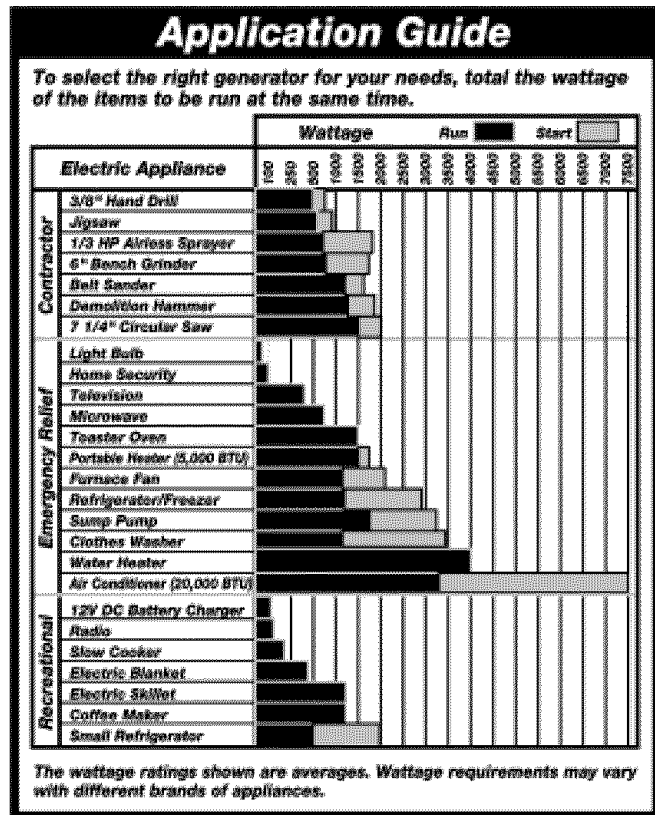

## OBTAINING ELECTRICITY FROM GENERATOR

There are basically two ways to obtain electricity from a generator:

- Use of extension cords directly from the generator to the appliance, lights, tools, etc.
- Use of a double-throw transfer switch installed directly to the main electrical supply outside of the house.

### Extension Cord

When using an appliance or tool at a considerable distance from the generator, a 3-wire extension cord that has a 3-blade grounding plug and a 3-slot receptacle that accepts the tool's plug **MUST** be used in order to reduce the risk of electrical shock. A cord of adequate size must be used. A minimum of 12 gauge wire size with at least a 20 amp draw can be used. When amperage exceeds 20 amps a 10 gauge wire size should be used.

**⚠ WARNING** An extension cord that is hot to the touch is overloaded. Repair or replace damaged extension cords immediately.

## Connecting Generator To Main Electrical Supply

Potential hazards exist when a electrical generator is connected to the main electrical supply coming into the house. It is at that point that the generator could feed back into the utility company's system causing possible electrocution of workers who are repairing electrical lines. To avoid back feeding of electricity into utility systems, a **double-throw transfer switch** should be installed between the generator and utility power. This device should be installed by a licensed electrician and in compliance with all local electrical codes.

**NOTE:** When installing a Double-Throw Transfer Switch, a minimum of 10 gauge wiring must be used.

### BEFORE STARTING ENGINE

**CAUTION** Always check engine oil level before every start. Running engine low of oil or out of oil could result in serious damage to the engine.

### Adding Engine Oil

Your generator has been shipped **without** oil in the engine. Begin by removing the oil dipstick and plug. Start pouring the oil in slowly.

The engine will hold approximately 26 ounces of oil. To check the oil, clean and replace the dipstick. Do not screw the dip stick in when checking the oil level. Next, remove the dipstick to check the level. The oil dipstick is clearly marked with lines that tell you when the engine has enough oil. **Do not fill above this point.**

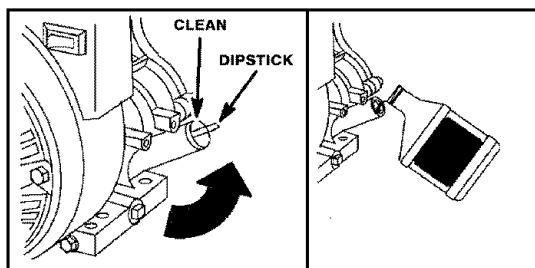

**NOTE:** When adding oil to the engine crankcase, use a high quality detergent oil classified "For Service SF,SG,SH" rated SAE 30 weight. Use no special additives. Select the oil's viscosity grade according to your expected operating temperatures.

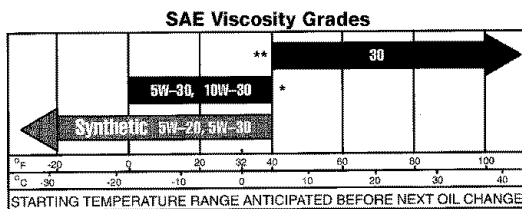

### Gasoline

Your generator engine is 4 cycle. Use unleaded fuel only. Never mix oil with gasoline.

- Remove gas cap.
- Add unleaded gasoline, slowly, to fuel tank.

Use clean, fresh, regular unleaded gasoline with a minimum of 85 octane. Do not mix oil with gasoline.

**CAUTION** Never fill fuel tank completely. Fill tank to 1/2" below the bottom of the filler neck to provide space for fuel expansion. Wipe any fuel spillage from engine and equipment before starting engine.

- Do not overfill.

**WARNING** Never fill fuel tank indoors. Never fill fuel tank when engine is running or hot. Do not smoke when filling fuel tank.

### To Start Your Generator

**CAUTION** Never run engine indoors or in enclosed, poor ventilated areas. Engine exhaust contains carbon monoxide, an odorless and deadly gas.

- Open the fuel shut-off valve. Turn counter clockwise until the valve stops.



- On the engine there is a ON/OFF switch located on the front panel of the engine. Place this switch to the "ON" position.

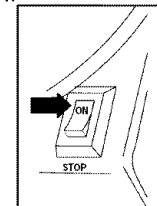

- Move the choke control located on the engine to "FULL CHOKE" position.

**NOTE:** No choke is required on warm engines. Make sure choke is in the "NO CHOKE" position on warm

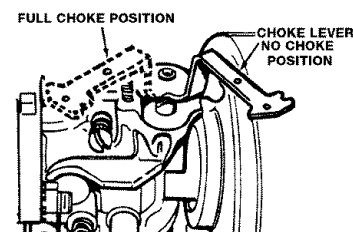

**CAUTION**

engine starts.

**You MUST unplug any load from the generator before starting to prevent permanent damage to any appliances.**

- Grasp handle on rope starter and pull slowly until resistance is felt. Let the rope rewind slowly. Pull rope with a rapid full arm stroke. Let rope rewind slowly. Repeat if necessary.

**NOTE: IF ENGINE OIL LEVEL IS TOO LOW, ENGINE WILL NOT START. CHECK OIL LEVEL AND ADD IF NECESSARY.**

- When engine starts, gradually move the choke to the "NO CHOKE" position.

**IMPORTANT:** Allow generator to run at no load for 5 minutes upon each initial start-up to allow engine and generator to stabilize.

**STOPPING ENGINE**

- Disconnect all electrical loads.
- Turn ON/OFF switch to "STOP" position.
- Close fuel shut-off valve.

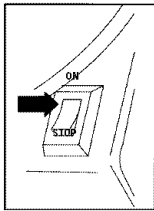

**IMPORTANT:** Never store engine with fuel in tank, indoors, or in enclosed, poorly ventilated areas or where fuel fumes may reach an open flame.

**CONNECTING ELECTRICAL LOADS**

- Let engine run and warm up for five minutes after starting with no electrical load.

Connect loads in the following manner to prevent damage to equipment:

- Connect inductive load equipment first, inductive loads consist of refrigerators, freezers, water pumps, air conditioners, or small hand tools. Connect the items that require the most wattage first.
- Connect the lights next.
- Voltage sensitive equipment should be the last equipment connected to the generator. Plug voltage sensitive appliances such as TV's, VCR's, microwaves, ovens, computers, and cordless telephones into a UL listed voltage surge protector, then connect the UL listed voltage surge protector to the generator.

**IMPORTANT:** You should always add up the rated watts of all lights, tools and appliances you are powering at one time. This total should not exceed the rated capacity of you generator or circuit breaker rating of the receptacle supplying power.

**MAINTENANCE****CUSTOMER RESPONSIBILITIES TABLE**

MAINTENANCE TASK	Before each use	Every 25 Hours of Every Season	Every 50 Hours of Every Season	Every 100 Hours of Every Season
Check oil level	X	See Note 2		
Change oil			See Note 1	
Clean Air Filter Assembly		X		
Check Spark Plug		X		X
Prepare Unit for Storage	<b>Prepare unit for storage if it is to remain idle for more than 30 days.</b>			

**Note 1:** Change oil after first two (2) operating hours and every 50 operating hours thereafter, more often if operated in extreme dusty or dirty conditions.

**Note 2:** Check oil after 5 hours of operation (See the **Oil** paragraph on page 15 of this section)

## GENERAL RECOMMENDATIONS

The warranty of the generator does not cover items that have been subjected to operator abuse or negligence. To receive full value from the warranty, operator must maintain the generator as instructed in this manual.

Some adjustments will need to be made periodically to maintain your generator.

## GENERATOR MAINTENANCE

Your generator should be kept clean and dry at all times. The generator should not be stored or operated in environments that include excessive moisture, dust or any corrosive vapors. If these substances are on the generator, clean with a cloth or soft bristle brush. Do not use a garden hose or anything with water pressure to clean the generator. Water may enter the cooling air slots and could possibly damage the rotor, stator and the internal windings of the generator head.

All adjustments in the Maintenance section of this manual should be made at least once each season.

## ENGINE MAINTENANCE

**NOTICE: Maintenance, replacement or repair of the emission control devices and systems may be performed by any nonroad engine repair establishment or individual. However, to obtain no charge repairs under the terms and provisions of the engine manufacturers warranty statement, any service or emission control part repair or replacement must be performed by a factory authorized dealer.**

### Oil

- Oil level should be checked prior to each use and at least every 5 hours of operation. To check oil see **Adding Engine Oil** paragraph in the Operation section on page 13.

### Changing Engine Oil

For a new engine, change oil after the first **2 operating hours**. Thereafter, change oil after every **50 hours** of operation.

Change the oil while the engine is still warm. The oil will flow freely and carry away more impurities. Make sure the engine is level when filling, checking or changing oil.

#### Change the oil as follows:

- To keep dirt, grass clippings, etc. out of the engine, clean the area around the drain plug and dipstick before removing it.
- Remove the oil drain plug and dipstick. Tilt the engine slightly towards the oil drain to obtain better drainage. Be sure to allow ample time for complete drainage.

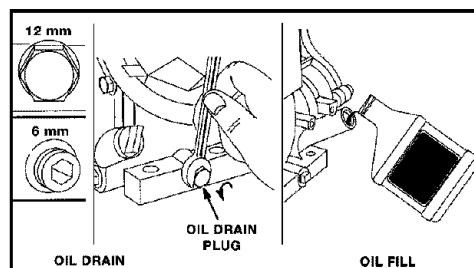

- Reinstall the drain plug. Make sure it is tightened securely.
- Fill the crankcase with new oil of the proper type (See Adding Engine Oil in the Operation Section), to the Full mark on the dipstick. Always check the level with the dipstick before adding more oil.

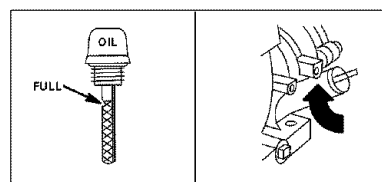

- Reinstall the oil fill cap or plug and tighten securely.

### Service Air Cleaner

**NOTE:** Do not use petroleum solvents, e.g., kerosene, which will cause the cartridge to deteriorate. Do not use pressurized air to clean cartridge. Pressurized air can damage the cartridge.

#### To service air cleaner follow these steps:

- Unscrew wing nut. Remove cover and air cleaner cartridge.
- Remove cartridge from cover.

To service cartridge, clean by tapping gently on a flat service. Do not oil cartridge. Replace if dirty or damaged.

- Replace air cleaner cartridge. Place cover over cartridge and tighten nut finger tight and then turn it one more complete turn.

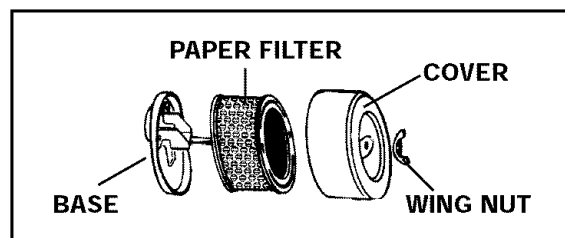

## Clean Guard/Muffler

Do not clean with a forceful spray of water because water could contaminate fuel system. With a brush or cloth clean finger guard after every use to prevent engine damage caused by overheating. Before running engine, clean muffler area to remove all combustible debris.

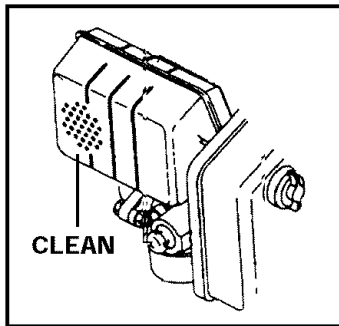
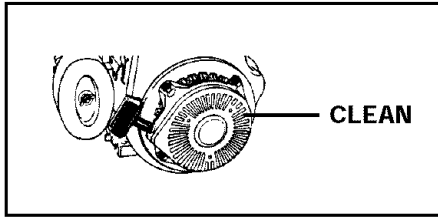

## Clean and Replace Spark Plug

Check spark plug yearly or every 100 operating hours.

- Clean area around spark plug.
- Remove and inspect spark plug.
- Replace spark plug if electrodes are pitted, burned or porcelain is cracked. For replacement use Champion RJ17LM resistor spark plug.
- Check electrode gap with wire feeler gauge and set gap .030 if necessary.
- Install spark, tighten securely.

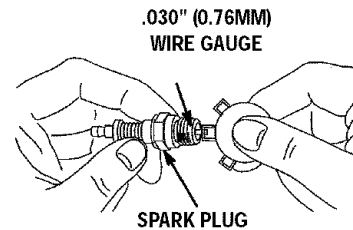

# SERVICE ADJUSTMENTS

## CARBURETOR

The carburetor of your generator is pre-set at the factory. The carburetor should not be tampered with. If your generator is used at an altitude in excess of 4000 feet performance may be affected. If so consult with your nearest Craftsman Service Center regarding high altitude set changes.

## GOVERNOR

Your engine governor maintains the constant operating speed of your generator. **DO NOT** tamper with the engine governor which is factory set for proper engine speed.

Over-speeding your engine above factory high speed setting can be dangerous and could possibly cause personal injury or property damage. If you believe the engine is running too fast or slow, take your generator to a Authorized Craftsman Service Center for repair and adjustment.

**⚠ CAUTION** Low engine speeds impose a heavy load on the engine and when sufficient power is not available the engine life could be shortened.



# STORAGE

If you are going to store your generator for more than 30 days, use the following information as a guide to prepare the generator for storage.

**CAUTION** Never store generator with fuel in the tank indoors or in enclosed, poorly ventilated areas, where fumes can reach an open flame, spark or pilot light as on a furnace, water heater, clothes dryer or other gas appliances.

## Engine Preparation

- Add fuel stabilizer to fuel tank to minimize the formation of fuel gum deposits during storage.
- Run engine at least 10 minutes after adding stabilizer to allow it to enter the fuel system.

- Disconnect the spark plug wire and remove the spark plug.
- Add one teaspoon of oil through the spark plug hole.
- Place rag over spark plug hole and pull the recoil a few times to lubricate the combustion chamber. Replace the spark plug, but do not connect the spark plug wire.

**NOTE:** If a fuel stabilizer is not used, all gasoline must be drained from the tank and carburetor to prevent gum deposits from forming on these parts and causing possible malfunction of the engine.

## Generator

- Clean the generator as outlined in the Generator Maintenance paragraph on page 15.
- Check that cooling air slots and openings on generator are open and unobstructed.

# TROUBLESHOOTING GUIDE

<b>PROBLEM</b>	<b>CAUSE</b>	<b>CORRECTION</b>
<b>Engine will not start</b>	<ol style="list-style-type: none"> <li>1. Low on fuel or oil.</li> <li>2. Ignition switch in "Off" position.</li> <li>3. Faulty spark plug.</li> <li>4. Choke in wrong position.</li> <li>5. Fuel shut-off valve in closed position.</li> <li>6. Unit loaded during start-up.</li> <li>7. Spark plug wire loose.</li> </ol>	<ol style="list-style-type: none"> <li>1. Add fuel or oil.</li> <li>2. Turn to "ON" position</li> <li>3. Replace spark plug.</li> <li>4. Adjust choke accordingly.</li> <li>5. Open fuel shut-off valve.</li> <li>6. Remove load from unit.</li> <li>7. Attach wire to spark plug.</li> </ol>
<b>No electrical output</b>	<ol style="list-style-type: none"> <li>1. Faulty receptacle.</li> <li>2. Circuit breaker kicked out.</li> <li>3. Defective capacitor.</li> <li>4. Faulty power cord.</li> </ol>	<ol style="list-style-type: none"> <li>1. Have Authorized Sears Service Center replace.</li> <li>2. Depress and reset.</li> <li>3. Have Authorized Sears Service Center replace capacitor.</li> <li>4. Repair or replace cord.</li> </ol>
<b>Repeated circuit breaker tripping</b>	<ol style="list-style-type: none"> <li>1. Overload</li> <li>2. Faulty cords or equipment.</li> </ol>	<ol style="list-style-type: none"> <li>1. Reduce load.</li> <li>2. Check for damaged, bare, or frayed wires on equipment. Replace.</li> </ol>
<b>Generator overheating the circuit breaker depressed</b>	<ol style="list-style-type: none"> <li>1. Generator overloaded.</li> <li>2. Insufficient ventilation.</li> </ol>	<ol style="list-style-type: none"> <li>1. Reduce load.</li> <li>2. Move to adequate supply of fresh air.</li> </ol>

# GENERATOR PARTS

CRAFTSMAN 5000 GENERATOR 919.679501

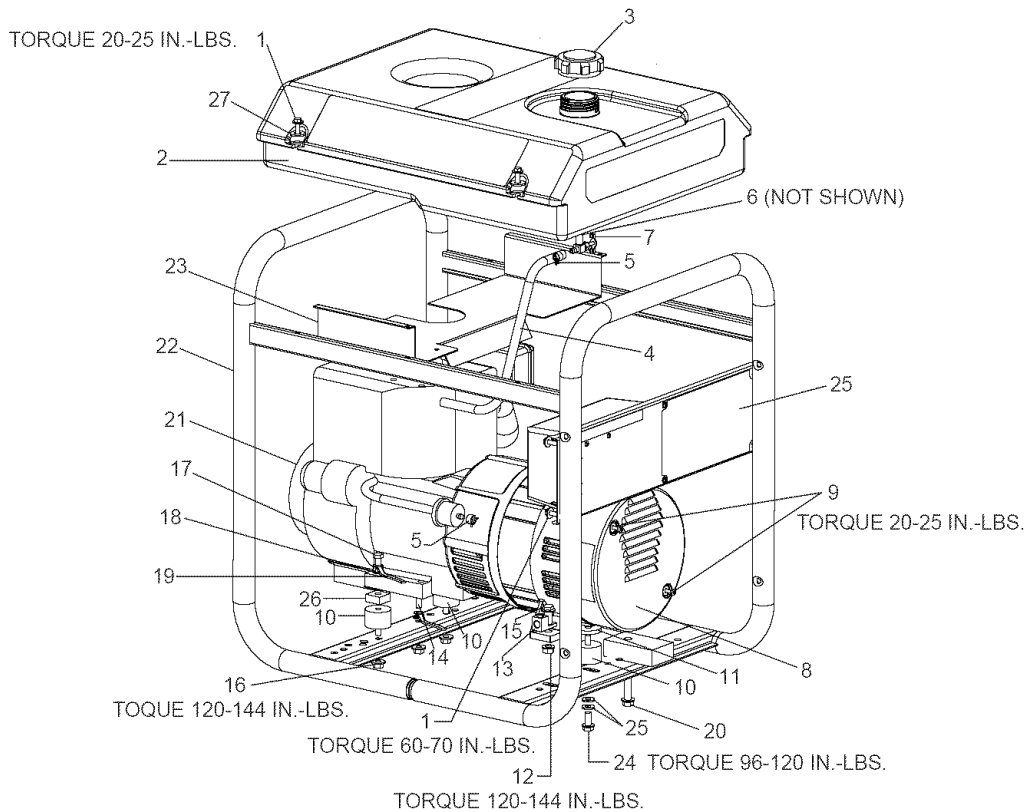

**KEY  
NO.**

**DESCRIPTION**

**PART NUMBER**

1	FUEL TANK SCREWS	91895680
2	FUEL TANK	GS-0795
3	FUEL CAP	GS-0443
4	FUEL HOSE	GS-0225
5	FUEL LINE CLAMP	GS-0227
6	DRAINCOCK GROMMET	GS-0446
7	FUEL SHUT-OFF VALVE	GS-0437
8	ENDCOVER	GS-0077
9	SCREW #10-24 x 9/16	SSF-553-1
10	ISOLATOR	GS-0033
11	WASHER 1-1/2 OD	SSN-1014-ZN
12	LOCK NUT 3/8-16	SSF-8111-ZN
13	GROUND LUG	GS-0117
14	SCREW 5/16-18 x 3/4	SS-12-CD
15	SCREW 3/8-16 x 1	SSF-3140-ZN
16	LOCK NUT 5/16-18	SSF-8150
17	SCREW, HEX HEAD 5/16-18	SSF-999-1
18	LOCK WASHER	SSN-1619-ZN
19	GROUND STRAP	GS-0118
20	HEX SCREW 3/8-16X2.5	SSF-628
21	ENGINE	GS-0501
22	FRAME ASSEMBLY	GS-0798
23	HEAT SHIELD	GS-0432-1
24	SCREW 5/16-18 X .5	SSF-549
25	PANEL ASSEMBLY	GS-0807
26	SPACER ENGINE	GS-0746
27	WASHER .8750D .3751D .083THK	SSN-632

# GENERATOR PARTS

CRAFTSMAN 5000 GENERATOR 919.679501

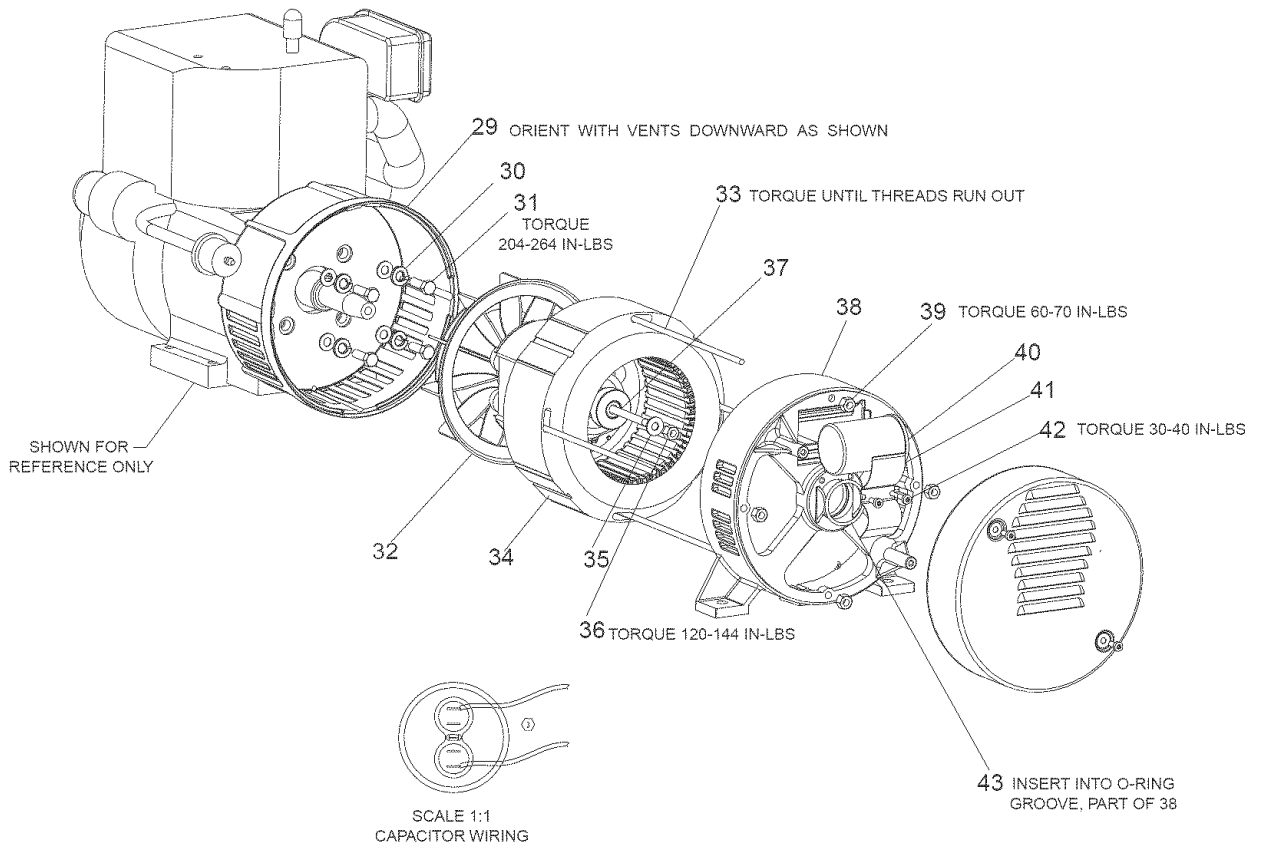

## KEY

<u>NO.</u>	<u>DESCRIPTION</u>	<u>PART NUMBER</u>
29	DRIVE END ADAPTER	GS-0511
30	LOCK WASHER 3/8	SS-1503-CD
31	CAP SCREW 5/16 - 24X1	SSF-616-ZN
32	ROTOR ASSEMBLY	GS-0883
33	STATOR THRU BOLT	GS-0110
34	STATOR ASSEMBLY	GS-0884
35	WASHER 11/16OD x 11/32	SS-6506-CD
36	NUT 5/16-24	SSF-576
37	ROTOR THRU BOLT	GS-0091-1
38	BEARING SUPPORT	GS-0861
39	HEX NUT 1/4-20	SSF-575
40	CAPACITOR	GS-0873
41	CAPACITOR BRACKET	GS-0595
42	SCREW 10 - 24 x 9/16	SSF-553-1
43	O-RING	GS-0862

# GENERATOR PARTS

CRAFTSMAN 5000 GENERATOR 919.679501

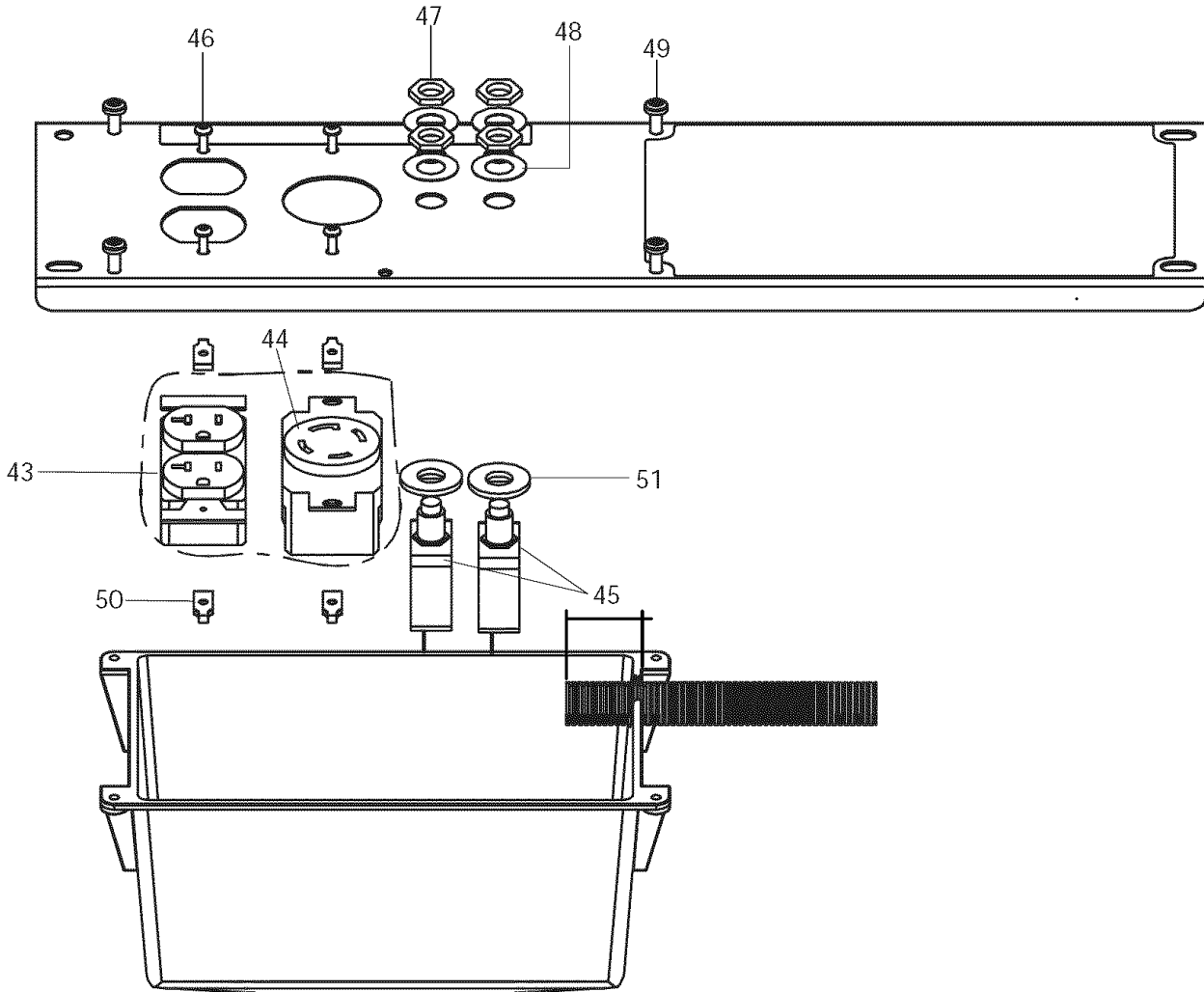

**KEY**

<u>NO.</u>	<u>DESCRIPTION</u>	<u>PART NUMBER</u>
43	120V/20A DUPLEX RECEPTACLE	GS-0019
44	4 PRONG TWISTLOCK	GS-0445
45	CIRCUIT BREAKER 120/240V/20A	GS-0025
46	SCREW #6 - 32 x .5 TORX	SSF-583
47	NUT, 10 - 9 X .50 PLASTITE	SSF-3156
48	SWITCH FACE PLATE RESET	GS-0207
49	NUT, HEX JAM 7/16	SSF-595
50	SPEED NUT #6 - 32	SSF-584
51	WASHER 3/8	SS-1525-CD

# ENGINE PARTS

CRAFTSMAN 5000 GENERATOR 919.679501

TECUMSEH 4-CYCLE ENGINE MODEL #HM100-159409P

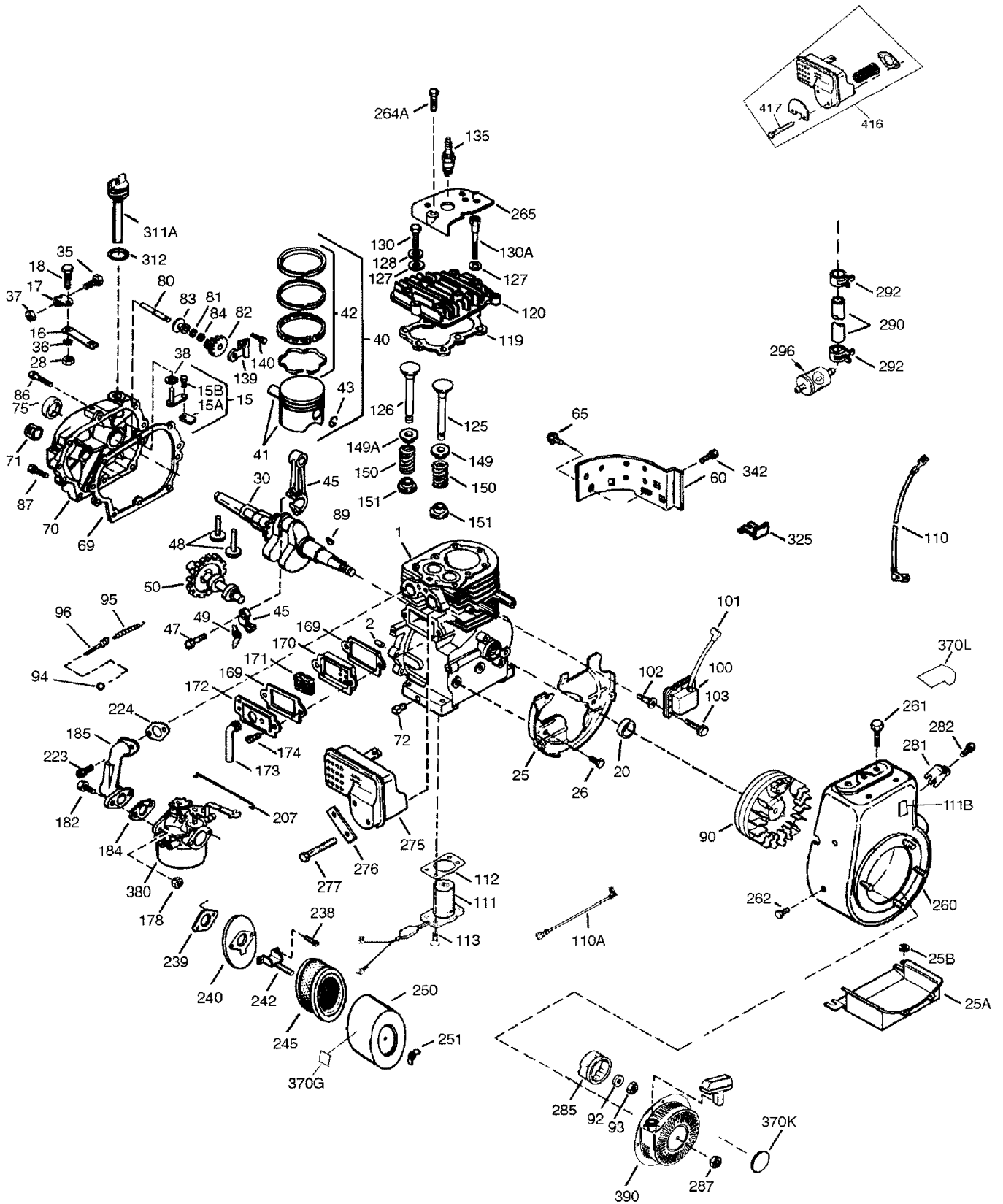

# ENGINE PARTS

CRAFTSMAN 5000 GENERATOR 919.679501

TECUMSEH 4-CYCLE ENGINE MODEL #HM100-159409P

REF. NO.	PART NO.	DESCRIPTION	REF. NO.	PART NO.	DESCRIPTION
1	35968A	CYLINDER (INCL. #2, 20 & 72)	125	27878A	EXHAUST VALVE (STD.) (INCL. #151)
2	27652	DOWEL PIN	125	27880A	EXHAUST VALVE (1/32" OS) (INCL. #151)
15	30699C	GOVERNOR ROD (INCL. #15A & 15B)	126	34035	INTAKE VALVE (STD.) (INCL. #151)
15A	30700	GOVERNOR YOKE	126	34036	INTAKE VALVE (1/32" OS) (INCL. #151)
15B	650494	SCREW, 6-40 X 5/16"	127	650691	WASHER
16	33454A	GOVERNOR LEVER	128	650690	BELLEVILLE WASHER
17	29916	GOVERNOR LEVER CLAMP	130	650694A	SCREW, 5/16-18 X 2"
18	651028	SCREW, TORX T-15, 8-32 X 3/8"	130A	651031	SCREW, 1/4-20 X 9/16"
20	35319	OIL SEAL	135	33636	RESISTOR SPARK PLUG (RJ17LM)
25	36460	BLOWER HOUSING BAFFLE	139	33369	GOVERNOR GEAR BRACKET
25A	36244	AIR BAFFLE	140	650836	SCREW, 10-24 X 1/2"
25B	651059	SCREW, 3/8-16 X 47/64"	149	27882	VALVE SPRING CAP
26	650561	SCREW, 1/4-20 X 5/8"	149A	35862	VALVE SPRING CAP
28	30322	LOCK NUT, 8-32	150	27881	VALVE SPRING
30	37302	CRANKSHAFT	151	32581	VALVE SPRING KEEPER
35	29826	SCREW, 10-32 X 3/4"	169	27896A	BREATHER GASKET (KIT)
36	29918	LOCK WASHER	170	28423	BREATHER BODY
37	29216	LOCK NUT, 10-32	171	28424	BREATHER ELEMENT
38	29642	RETAINING RING	172	28425	VALVE COVER
40	35776A	PISTON, PIN & RING SET (STD.)	173	35350	BREATHER TUBE
40	35777A	PISTON, PIN & RING SET (.010" OS)	174	650128	SCREW, 10-24 X 1/2"
40	35778A	PISTON, PIN & RING SET (.020" OS)	178	29752	NUT & LOCK WASHER 1/4-28
41	35773A	PISTON, PIN & ASS'Y (STD.) (INCL. #43)	182	30088A	SCREW, 1/4-28 X 1"
41	35774A	PISTON, PIN & ASS'Y (.010" OS) (INCL. #43)	184	33263	CARBURETOR TO INTAKE PIPE GASKET (KIT)
41	35775A	PISTON, PIN & ASS'Y (.020" OS) (INCL. #43)	185	33877	INTAKE PIPE
42	35779	RING SET (STD.)	207	33878	THROTTLE LINK
42	35780	RING SET (.010" OS)	223	650378	SCREW, TORX T-30, 5/16-18 X 1-1/8"
42	35781	RING SET (.020" OS)	224	27915A	INTAKE PIPE GASKET (KIT)
43	35772	PISTON PIN RETAINING SET	238	28820	SCREW, 10-31 X 1/2"
45	36898	CONNECTING ROD ASS'Y. (INCL. #47 & 49)	239	27272A	AIR CLEANER GASKET (KIT)
47	651033	CONNECTING ROD BOLT	240	33266	AIR CLEANER BRACKET
48	34034	VALVE LIFTER	242	33267	AIR CLEANER BRACKET
49	36896	OIL DIPPER	245	33268	AIR CLEANER FILTER
50	35375	CAMSHAFT (MCR)	250	33269A	AIR CLEANER COVER
60	33273A	BLOWER HOUSING EXTENSION	251	650513	WING NUT, 1/4-20
65	650128	SCREW, 10-24 X 1/2"	260	36468A	BLOWER HOUSING
69	35262A	CYLINDER COVER GASKET (KIT)	261	650788	SCREW, 5/16-18 X 3/4"
70	35376	CYLINDER COVER (INCL. #71, 75 & 80)	262	29747B	SCREW, TORX T-40, 5/16 - 24 X 21/32"
71	35377	CRANKSHAFT BUSHING	264A	650802	SCREW, 1/4-20 X 5/8"
72	27642	OIL DRAIN PLUG	265	33272B	CYLINDER HEAD COVER
75	35319	OIL SEAL	275	34185B	MUFFLER
80	31845	GOVERNOR SHAFT	276	31588	LOCKING PLATE
81	30590A	WASHER	277	650729	SCREW, 5/16 - 18 X 3 - 3/16"
82	35378	GOVERNOR GEAR ASS'Y (INCL. #81)	281	33013	STARTER BUBBLE COVER
83	30588A	GOVERNOR SPOOL	282	650760	SCREW, 10 - 32 X 3/8"
84	29893	RETAINING RING	285	35985B	STARTER CUP
86	650833	SCREW, 1/4-20 X 1-3/16"	287	29752	NUT & LOCK WASHER, 1/4 - 28
87	650832	SCREW, 1/4-20 X 1-11/16"	290	30962	FUEL LINE
89	32589	FLYWHEEL KEY	292	26460	FUEL LINE CLAMP
90	611090	FLYWHEEL	296	34279B	FUEL FILTER (INCL. 292)
92	650880	LOCK WASHER	311A	35941	OIL FILL RING
93	650881	FLYWHEEL NUT	312	29673	"O" RING
94	651016	LOCK NUT, 10-32	325	29443	WIRE CLIP
95	30886A	EXTENSION SPRING	342	30063	SCREW, TORX T-30, 1/4 - 20 X 1/2"
96	30845A	R.P.M. ADJUSTING BOLT	370G	35274	INSTRUCTION DECAL
100	35135	SOLID STATE IGNITION	370K	36695	STARTER DECAL
101	610118	SPARK PLUG COVER	370L	36990	LOW OIL DECAL
102	651024	SOLID STATE MOUNTING STUD	380	640152	CARBURETOR (INCL. 184)
103	651007	SCREW, TORX T-15, 10-24 X 15/16"	390	590746	REWIND STARTER
110	35589	GROUND SCREW			(NOTE: THIS ENGINE COULD HAVE BEEN BUILT WITH 590704 STARTER).
110A	36993	OIL SHUT-DOWN WIRE & TERMINAL	400	36452B	GASKET SET
111	611220	LOW OIL SHUT-DOWN SWITCH (INCL. #112)			(INCL. ITEMS MARKED PK IN NOTES)
111B	611226	ROCKER ON/OFF SWITCH			INCL. PART # 27272A, 27896A, 27915A,
112	35967	LOW OIL SHUT-DOWN GASKET (KIT)			29673, 33263, 33629, 34698A, 35262A,
113	650950	SCREW, TORX T-25, 10-24 X 5/8"			35317, 36451
119	36451	CYLINDER HEAD GASKET (KIT)	416	34479A	SPARK ARRESTOR KIT (INCL. 417) (OPTIONAL)
120	36449	CYLINDER HEAD	417	650696	SCREW, 5/16 - 18 X 2 - 45/64"
			420	730225	SAE 30 4-CYCLE ENGINE OIL (QUART)

# CARBURETOR PARTS

CRAFTSMAN 5000 GENERATOR 919.679501

CARBURETOR MODEL #64012 1A70-5097

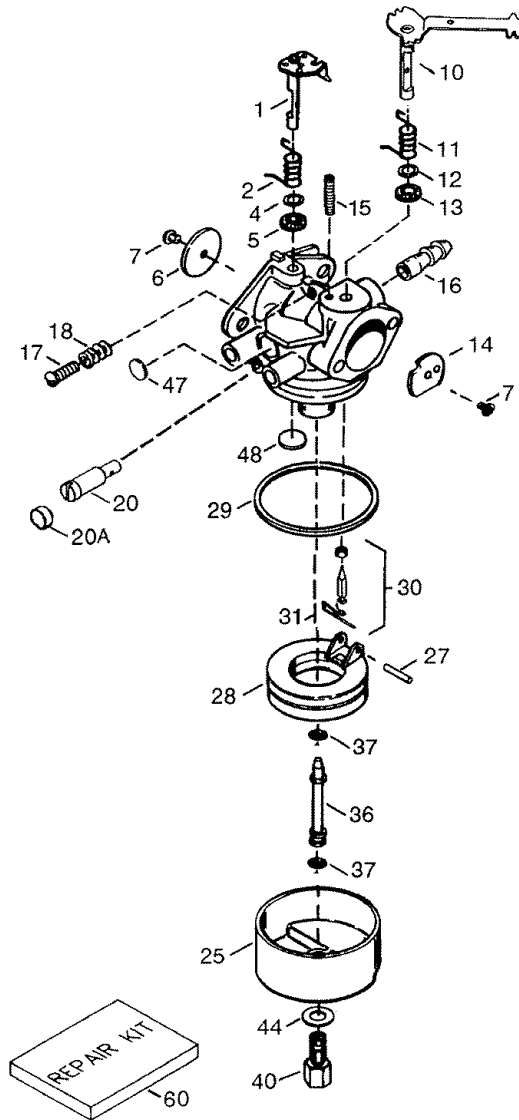

REF. NO.	PART NO.	DESCRIPTION
1	631776A	THROTTLE SHAFT & LEVER ASSEMBLY
2	631970	THROTTLE RETURN SPRING
4	631184	DUST SEAL WASHER (KIT)
5	631183	DUST SEAL (THROTTLE) (KIT)
6	640109	THROTTLE SHUTTER
7	650506	SHUTTER SCREW
10	632740	CHOKE SHAFT & LEVER ASSEMBLY
11	632043	CHOKE RETURN SPRING
12	631184	DUST SEAL WASHER (KIT)
13	631183	DUST SEAL (CHOKE) (KIT)
14	631753	CHOKE SHUTTER
15	630735	CHOKE POSITIONING SPRING
16	632164	FUEL FITTING
17	651925	THROTTLE CRACK SCREW/IDLE SPEED SCREW
18	630766	TENSION SPRING

REF. NO.	PART NO.	DESCRIPTION
20	640027	IDLE RESTRICTOR SCREW
20A	640053	IDLE RESTRICTOR SCREW CAP
25	631867	FLOAT BOWL
27	631024	FLOAT SHAFT (KIT)
28	632019	FLOAT
29	631028	FLOAT BOWL O-RING (KIT)
30	631021	INLET NEEDLE, SEAR & CLIP (INCL. #31) (KIT)
31	631022	SPRING CLIP
36	640113	MAIN NOZZLE TUBE
37	632547	MAIN NOZZLE TUBE O-RING (KIT)
40	640114	HIGH SPEED BOWL NUT
44	27110A	BOWL NUT WASHER
47	630748	WELCH PLUG, IDLE MIXTURE WELL (KIT)
48	631027	WELCH PLUG, ATMOSPHERIC VENT (KIT)
60	632760	REPAIR KIT (INCL. ITEMS MARKED PK IN NOTES)

# STARTER PARTS

CRAFTSMAN 5250 GENERATOR 919.679501

STARTER #590746

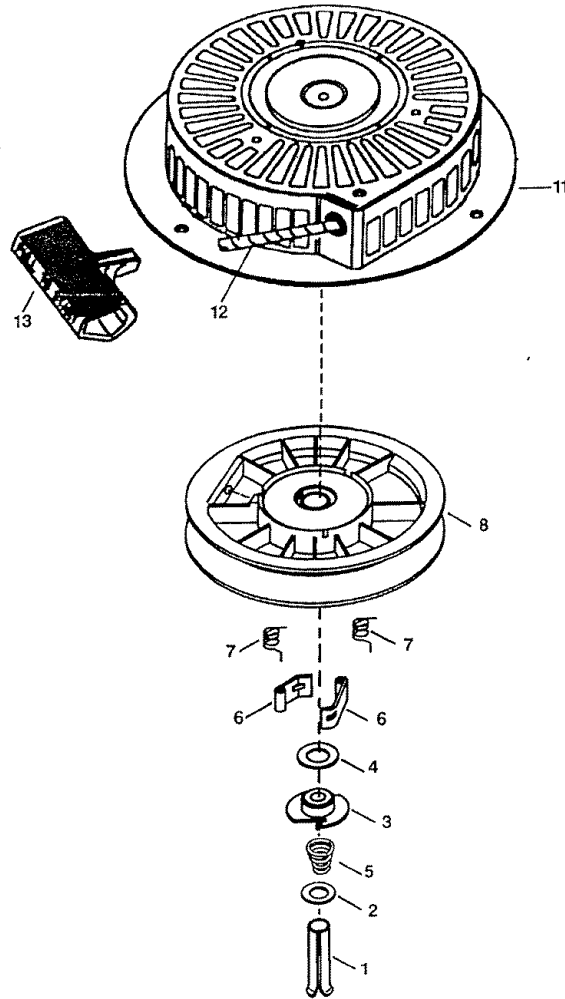

REF. NO.	PART NO.	DESCRIPTION
1	590599A	SPRING PIN (INCL. 4)
2	590600	WASHER
3	590679	RETAINER
4	590601	WASHER
5	590678	BRAKE SPRING
6	590680	STARTER DOG
7	590412	DOG SPRING
8	590681	PULLEY & REWIND SPRING ASSEMBLY
11	590747	STARTER HOUSING ASSEMBLY
12	590535	STARTER ROPE (LENGTH 98" X 9/64" DIA.)
13	590701	STARTER HANDLE



# CALIFORNIA & US EPA EMISSION CONTROL WARRANTY STATEMENT

The U. S. Environmental Protection Agency ("EPA"), the California Air Resources Board ("CARB") and Tecumseh Products Co. are pleased to explain the Federal and California Emission Control Systems Warranty on your new utility or lawn and garden equipment engine. In California, new 1995 and later utility and lawn and garden equipment engines must be designed, built and equipped to meet the State's stringent anti-smog standards. In other states, new 1997 and later model year engines must be designed, built and equipped, at the time of sale, to meet the U.S. EPA regulations for small non-road engines. Tecumseh Products Co. will warrant the emission control system on your utility or lawn and garden equipment engine for the periods of time listed below, provided there has been no abuse, neglect, unapproved modification, or improper maintenance of your utility or lawn and garden equipment engine.

Your emission control system may include parts such as the carburetor, ignition system and exhaust system. Also included may be the compression release system and other emission-related assemblies.

Where a warrantable condition exists, Tecumseh Products Co. will repair your utility or lawn and garden equipment engine at no cost to you for diagnosis, parts and labor.

## MANUFACTURER'S EMISSION CONTROL SYSTEM WARRANTY COVERAGE

Emission control systems on 1995 and later model year California utility and lawn and garden equipment engines are warranted for two years as hereinafter noted. In other states, 1997 and later model year engines are also warranted for two years. If, during such warranty period, any emission-related part on your engine is defective in materials or workmanship, the part will be repaired or replaced by Tecumseh Products Co.

## OWNER'S WARRANTY RESPONSIBILITIES

As the utility or lawn and garden equipment engine owner, you are responsible for the performance of the required maintenance listed in your Owner's Manual, but Tecumseh Products Co. will not deny warranty solely due to the lack of receipts or for your failure to provide written evidence of the performance of all scheduled maintenance.

As the utility or lawn and garden equipment engine owner, you should, however, be aware that Tecumseh Products Co. may deny you warranty coverage if your utility or lawn and garden equipment or a part thereof has failed due to abuse, neglect, improper maintenance or unapproved modifications.

You are responsible for presenting your utility or lawn and garden equipment engine to a Tecumseh Authorized Service Outlet (any Tecumseh Registered Service Dealer, Tecumseh Authorized Service Distributor or Tecumseh Central Warehouse Distributor) as soon as a problem exists. The warranty repairs should be completed in a reasonable amount of time, not to exceed 30 days.

Warranty service can be arranged by contacting either a Tecumseh Authorized Service Outlet or by contacting Tecumseh Products Co., c/o Service Manager, Engine and Transmission Group Service Division, 900 North Street, Grafton, WI 53024-1499. Telephone 1-414-377-2700, or see your local telephone yellow pages under "Engines, Gasoline" for the name, address and telephone number of a Tecumseh Authorized Service Outlet near you.

## IMPORTANT NOTE

This warranty statement explains your rights and obligations under the Emission Control System Warranty ("ECS Warranty") which is provided to you by Tecumseh Products Co. pursuant to California law. Tecumseh Products Co. also provides to original purchasers of new Tecumseh Products Co. engines. The Tecumseh Products Co. Limited Warranties for New Tecumseh Engine and Electronic Ignition Modules ("Tecumseh Products Co. Warranty") which is enclosed with all new Tecumseh Products Co. engines on a separate sheet. The ECS Warranty applies only to the emission control system of your new engine. To the extent that there is any conflict in terms between the ECS Warranty and the Tecumseh Products Co. Warranty, the ECS Warranty shall apply except in any circumstances in which the Tecumseh Products Co. Warranty may provide a longer warranty period. Both the ECS Warranty and the Tecumseh Products Co. Warranty describe important rights and obligations with respect to your new engine.

Warranty service can only be performed by a Tecumseh Products Co. Authorized Service Outlet, or by Tecumseh Products Co. at its factory in Grafton, WI. At the time of requesting warranty service, evidence must be presented of the date of sale to the original purchaser. The purchaser shall pay any charges for making service calls and/or for transporting the products to and from the place where the inspection and/or warranty work is performed. The purchaser shall be responsible for any damage or loss incurred in connection with the transportation of any engine or any part(s) thereof submitted for inspection and/or warranty work.

If you have any questions regarding your warranty rights and responsibilities, you should contact Tecumseh Products Co. at 1-414-377-2700.

# EMISSION CONTROL SYSTEM WARRANTY

Emission Control System Warranty ("ECS Warranty") for 1995 and later model year California utility and lawn and garden equipment engines (for other states, 1997 and later model year engines):

- A. **APPLICABILITY:** This warranty shall apply to 1995 and later model year California utility and lawn and garden equipment engines (for other states, 1997 and later model year engines). The ECS Warranty Period shall begin on the date the new engine or equipment is delivered to its original, end-use purchaser, and shall continue for 24 consecutive months thereafter.
- B. **GENERAL EMISSIONS WARRANTY COVERAGE:** Tecumseh Products Co. warrants to the original, end-use purchaser of the new engine or equipment and to each subsequent purchaser that each of its utility and lawn and garden equipment engines is:
1. Designed, built and equipped so as to conform with all applicable regulations adopted by the Air Resources Board pursuant to its authority in Chapters 1 and 2, Part 5, Division 26 of the Health and Safety Code, and
  2. Free from defects in materials and workmanship which, at any time during the ECS Warranty Period, will cause a warranted emissions-related part to fail to be identical in all material respects to the part as described in the engine manufacturer's application for certification.
- C. The ECS Warranty only pertains to emissions-related parts on your engine, as follows:
1. Any warranted, emissions-related parts which are not scheduled for replacement as required maintenance in the Owner's Manual shall be warranted for the ECS Warranty Period. If any such part fails during the ECS Warranty Period, it shall be repaired or replaced by Tecumseh Products Co. according to Subsection 4 below. Any such part repaired or replaced under the ECS Warranty shall be warranted for any remainder of the ECS Warranty Period.
  2. Any warranted, emissions-related part which is scheduled only for regular inspection as specified in the Owner's Manual shall be warranted for the ECS Warranty Period. A statement in such written instructions to the effect of "repair or replace as necessary", shall not reduce the ECS Warranty Period. Any such part repaired or replaced under the ECS Warranty shall be warranted for the remainder of the ECS Warranty Period.
  3. Any warranted, emissions-related part which is scheduled for replacement as required maintenance in the Owner's Manual, shall be warranted for the period of time prior to the first scheduled replacement point for that part. If the part fails prior to the first scheduled replacement, the part shall be repaired or replaced by Tecumseh Products Co. according to Subsection 4 below. Any such emissions-related part repaired or replaced under the ECS Warranty, shall be warranted for the remainder of the ECS Warranty Period prior to the first scheduled replacement point for such emissions-related part.
  4. Repair or replacement of any warranted, emissions-related part under this ECS Warranty shall be performed at no charge to the owner at a Tecumseh Authorized Service Outlet.
  5. The owner shall not be charged for diagnostic labor which leads to the determination that a part covered by the ECS Warranty is in fact defective, provided that such diagnostic work is performed at a Tecumseh Authorized Service Outlet.
  6. Tecumseh Products Co. shall be liable for damages to other original engine components or approved modifications proximately caused by a failure under warranty of an emission-related part covered by the ECS Warranty.
  7. Throughout the ECS Warranty Period, Tecumseh Products Co. shall maintain a supply of warranted emission-related parts sufficient to meet the expected demand for such emission-related parts.
  8. Any Tecumseh Products Co. authorized and approved emission-related replacement part may be used in the performance of any ECS Warranty maintenance or repair and will be provided without charge to the owner. Such use shall not reduce Tecumseh Products Co. ECS Warranty obligations.
  9. Unapproved add-on or modified parts may not be used to modify or repair a Tecumseh Products Co. engine. Such use voids this ECS Warranty and shall be sufficient grounds for disallowing an ECS Warranty claim. Tecumseh Products Co. shall not be liable hereunder for failures of any warranted parts of a Tecumseh Products Co. engine caused by the use of such an unapproved add-on or modified part.

## EMISSION-RELATED PARTS INCLUDE THE FOLLOWING:

1. Carburetor Assembly and its Internal Components
  - a) Fuel filter
  - b) Carburetor gaskets
  - c) Intake pipe
2. Air Cleaner Assembly
  - a) Air filter element
3. Ignition System, including:
  - a) Spark plug
  - b) Ignition module
4. Catalytic Muffler (if so equipped)
  - a) Muffler gasket (if so equipped)
  - b) Exhaust manifold (if so equipped)
5. Crankcase Breather Assembly and its Components
  - a) Breather connection tube

# NOTES

Dear Customer,

In manufacturing this product, many steps have been taken to provide you with the highest quality. Unfortunately, errors or omissions occasionally occur. In the event that you find a missing or defective part, please contact your nearest Sears store.

**SERVICE AND REPAIR PARTS**  
**CALL 1-800-665-4455 \***

Keep this number handy should you require a service call or need to order repair parts.

If ordering parts make sure you have the name, make and model no. of the merchandise and the name and number of the part you wish to order.

\* If calling locally, please use one of the following numbers:

Regina - 566-5124	Montreal - 333-5740
Toronto - 744-4900	Halifax - 454-2444
Kitchener - 894-7590	Ottawa - 738-4440
Vancouver - 420-8211	

If you have any suggestions that would help us to improve our assembly/operation instructions, or this product, please write them down and mail it to:

---

Sears Canada Inc.  
222 Jarvis Street  
Toronto, Ontario  
M5B 2B8

Attention: Buyer Dept: D671

Model No. \_\_\_\_\_

NAME \_\_\_\_\_

ADDRESS \_\_\_\_\_

POSTAL CODE \_\_\_\_\_ PHONE # \_\_\_\_\_

COMMENTS

\_\_\_\_\_  
\_\_\_\_\_  
\_\_\_\_\_  
\_\_\_\_\_