

Owner's Manual



GARDEN TRACTOR

24.0 HP, 48" Mower

Electric Start

Automatic Transmission

Model No.

917.276320

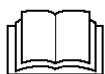
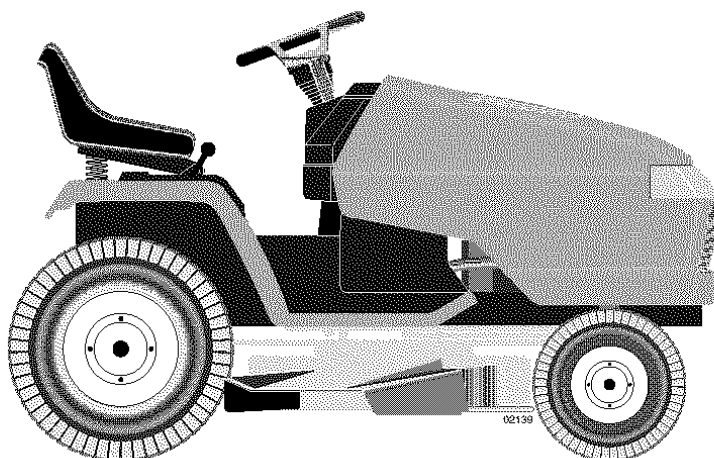

This product has a low emission engine which operates differently from previously built engines. Before you start the engine, read and understand this Owner's Manual.

IMPORTANT:

Read and follow all Safety Rules and Instructions before operating this equipment.

For answers to your questions about this product, Call:

1-800-659-5917

Sears Craftsman Help Line

5 am - 5 pm, Mon - Sat

Sears, Roebuck and Co., Hoffman Estates, IL 60179 U.S.A.

Visit our Craftsman website: www.sears.com/craftsman

TABLE OF CONTENTS

Warranty	2	Maintenance	16
Safety Rules	3	Service and Adjustments.....	20
Product Specifications	5	Storage	29
Assembly/Pre-Operation	7	Troubleshooting	30
Operation.....	9	Repair Parts.....	34
Maintenance Schedule	16	Sears Service	Back Cover

WARRANTY

LIMITED WARRANTY ON CRAFTSMAN RIDING EQUIPMENT

For two (2) years from the date of purchase, if this Craftsman Riding Equipment is maintained, lubricated and tuned up according to the instructions in the owner's manual, Sears will repair or replace free of charge any parts that are found to be defective in material or workmanship according to the guidelines of coverage listed below. Sears will also provide free labor for these applicable warranted parts for the two full years. During the first 30 days of purchase, there will be no charges to service the product at your home for issues covered by this warranty. (See exclusions below). For your convenience, IN HOME warranty service will still be available after the first 30 days of purchase, but a trip charge will apply. This charge will be waived if the Craftsman product is dropped off at an authorized Sears location. For the nearest authorized Sears location, please call 1-800-4-MY-HOME®. This warranty applies only while this product is within the United States.

This Warranty does not cover:

- Expendable items which become worn during normal use, including but not limited to blades, spark plugs, air cleaners, belts, and oil filters.
- Standard Maintenance Servicing, oil changes, or tune-ups.
- Tire replacement or repair caused by punctures from outside objects, such as nails, thorns, stumps, or glass.
- Repairs necessary because of operator abuse, including but not limited to, damage caused by towing objects beyond the capability of the riding equipment, impacting objects that bend the frame or crankshaft, or over-speeding the engine.
- Repairs necessary because of operator negligence, including but not limited to, electrical and mechanical damage caused by improper storage, failure to use the proper grade and amount of engine oil, failure to keep the deck clear of flammable debris, or failure to maintain the equipment according to the instructions contained in the owner's manual.
- Engine (fuel system) cleaning or repairs caused by fuel determined to be contaminated or oxidized (stale). In general, fuel should be used within 30 days of its purchase date.
- Normal deterioration and wear of the exterior finishes, or product label replacement.
- Riding equipment used for commercial or rental purposes.

LIMITED WARRANTY ON BATTERY

For ninety (90) days from date of purchase, if any battery included with this riding equipment proves defective in material or workmanship and our testing determines the battery will not hold a charge, Sears will replace the battery at no charge. During the first 30 days of purchase, there will be no charges to replace the battery at your HOME. After the first 30 days, for your convenience, IN-HOME warranty service will still be available but a trip charge will apply. This charge will be waived if the Craftsman product is dropped off at an authorized Sears location. For the nearest authorized Sears location, please call 1-800-4-MY-HOME®.

This battery warranty applies only while this product is within the United States.

This warranty gives you specific legal rights, and you may also have other rights, which vary, from state to state.

Sears, Roebuck and Co., Dept. 817WA, Hoffman Estates, IL 60179

SAFETY RULES

IMPORTANT: This cutting machine is capable of amputating hands and feet and throwing objects. Failure to observe the following safety instructions could result in serious injury or death.

 **WARNING:** In order to prevent accidental starting when setting up, transporting, adjusting or making repairs, always disconnect spark plug wire and place wire where it cannot contact spark plug.

 **WARNING:** Do not coast down a hill in neutral, you may lose control of the tractor.

 **WARNING:** Tow only the attachments that are recommended by and comply with specifications of the manufacturer of your tractor. Use common sense when towing. Operate only at the lowest possible speed when on a slope. Too heavy of a load, while on a slope, is dangerous. Tires can lose traction with the ground and cause you to lose control of your tractor.

 **WARNING:** Engine exhaust, some of its constituents, and certain vehicle components contain or emit chemicals known to the State of California to cause cancer and birth defects or other reproductive harm.

 **WARNING:** Battery posts, terminals and related accessories contain lead and lead compounds, chemicals known to the State of California to cause cancer and birth defects or other reproductive harm.
Wash hands after handling.

I. GENERAL OPERATION

- Read, understand, and follow all instructions on the machine and in the manual before starting.
- Do not put hands or feet near rotating parts or under the machine. Keep clear of the discharge opening at all times.
- Only allow responsible adults, who are familiar with the instructions, to operate the machine.
- Clear the area of objects such as rocks, toys, wire, etc., which could be picked up and thrown by the blades.
- Be sure the area is clear of bystanders before operating. Stop machine if anyone enters the area.
- Never carry passengers.
- Do not mow in reverse unless absolutely necessary. Always look down and behind before and while backing.

- Never direct discharged material toward anyone. Avoid discharging material against a wall or obstruction. Material may ricochet back toward the operator. Stop the blades when crossing gravel surfaces.
- Do not operate machine without the entire grass catcher, discharge guard, or other safety devices in place and working.
- Slow down before turning.
- Never leave a running machine unattended. Always turn off blades, set parking brake, stop engine, and remove keys before dismounting.
- Disengage blades when not mowing. Shut off engine and wait for all parts to come to a complete stop before cleaning the machine, removing the grass catcher, or unclogging the discharge guard.
- Operate machine only in daylight or good artificial light.
- Do not operate the machine while under the influence of alcohol or drugs.
- Watch for traffic when operating near or crossing roadways.
- Use extra care when loading or unloading the machine into a trailer or truck.
- Always wear eye protection when operating machine.
- Data indicates that operators, age 60 years and above, are involved in a large percentage of riding mower-related injuries. These operators should evaluate their ability to operate the riding mower safely enough to protect themselves and others from serious injury.
- Follow the manufacturer's recommendation for wheel weights or counterweights.
- Keep machine free of grass, leaves or other debris build-up which can touch hot exhaust / engine parts and burn. Do not allow the mower deck to plow leaves or other debris which can cause build-up to occur. Clean any oil or fuel spillage before operating or storing the machine. Allow machine to cool before storage.

SAFETY RULES

II. SLOPE OPERATION

Slopes are a major factor related to loss of control and tip-over accidents, which can result in severe injury or death. Operation on all slopes requires extra caution. If you cannot back up the slope or if you feel uneasy on it, do not mow it.

- Mow up and down slopes, not across.
- Watch for holes, ruts, bumps, rocks, or other hidden objects. Uneven terrain could overturn the machine. Tall grass can hide obstacles.
- Choose a low ground speed so that you will not have to stop or shift while on the slope.
- Do not mow on wet grass. Tires may lose traction.
Always keep the machine in gear when going down slopes. Do not shift to neutral and coast downhill.
- Avoid starting, stopping, or turning on a slope. If the tires lose traction, disengage the blades and proceed slowly straight down the slope.
- Keep all movement on the slopes slow and gradual. Do not make sudden changes in speed or direction, which could cause the machine to roll over.
- Use extra care while operating machine with grass catchers or other attachments; they can affect the stability of the machine. Do not use on steep slopes.
- Do not try to stabilize the machine by putting your foot on the ground.
- Do not mow near drop-offs, ditches, or embankments. The machine could suddenly roll over if a wheel is over the edge or if the edge caves in.

III. CHILDREN

Tragic accidents can occur if the operator is not alert to the presence of children. Children are often attracted to the machine and the mowing activity. Never assume that children will remain where you last saw them.

- Keep children out of the mowing area and in the watchful care of a responsible adult other than the operator.
- Be alert and turn machine off if a child enters the area.
- Before and while backing, look behind and down for small children.

- Never carry children, even with the blades shut off. They may fall off and be seriously injured or interfere with safe machine operation. Children who have been given rides in the past may suddenly appear in the mowing area for another ride and be run over or backed over by the machine.
- Never allow children to operate the machine.
- Use extra care when approaching blind corners, shrubs, trees, or other objects that may block your view of a child.

IV. TOWING

- Tow only with a machine that has a hitch designed for towing. Do not attach towed equipment except at the hitch point.
- Follow the manufacturer's recommendation for weight limits for towed equipment and towing on slopes.
- Never allow children or others in or on towed equipment.
- On slopes, the weight of the towed equipment may cause loss of traction and loss of control.
- Travel slowly and allow extra distance to stop.

V. SERVICE

SAFE HANDLING OF GASOLINE

To avoid personal injury or property damage, use extreme care in handling gasoline. Gasoline is extremely flammable and the vapors are explosive.

- Extinguish all cigarettes, cigars, pipes, and other sources of ignition.
- Use only approved gasoline container.
- Never remove gas cap or add fuel with the engine running. Allow engine to cool before refueling.
- Never fuel the machine indoors.
- Never store the machine or fuel container where there is an open flame, spark, or pilot light such as on a water heater or other appliances.
- Never fill containers inside a vehicle or on a truck or trailer bed with plastic liner. Always place containers on the ground away from your vehicle when filling.

SAFETY RULES

- Remove gas-powered equipment from the truck or trailer and refuel it on the ground. If this is not possible, then refuel such equipment with a portable container, rather than from a gasoline dispenser nozzle.
- Keep the nozzle in contact with the rim of the fuel tank or container opening at all times until fueling is complete. Do not use a nozzle lock-open device.
- If fuel is spilled on clothing, change clothing immediately.
- Never overfill fuel tank. Replace gas cap and tighten securely.
- Check their proper operation regularly.
- Keep machine free of grass, leaves, or other debris build-up. Clean oil or fuel spillage and remove any fuel-soaked debris. Allow machine to cool before storing.
- If you strike a foreign object, stop and inspect the machine. Repair, if necessary, before restarting.
- Never make any adjustments or repairs with the engine running.
- Check grass catcher components and the discharge guard frequently and replace with manufacturer's recommended parts, when necessary.
- Mower blades are sharp. Wrap the blade or wear gloves, and use extra caution when servicing them.
- Check brake operation frequently. Adjust and service as required.
- Maintain or replace safety and instruction labels, as necessary.

GENERAL SERVICE

- Never operate machine in a closed area.
- Keep all nuts and bolts tight to be sure the equipment is in safe working condition.
- Never tamper with safety devices.

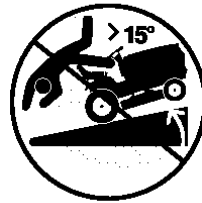

- Be sure the area is clear of bystanders before operating. Stop machine if anyone enters the area.
- Never carry passengers.
- Do not mow in reverse unless absolutely necessary. Always look down and behind before and while backing.
- Never carry children, even with the blades shut off. They may fall off and be seriously injured or interfere with safe machine operation. Children who have been given rides in the past may suddenly appear in the mowing area for another ride and be run over or backed over by the machine.
- Keep children out of the mowing area and in the watchful care of a responsible adult other than the operator.
- Be alert and turn machine off if a child enters the area.
- Before and while backing, look behind and down for small children.
- Mow up and down slopes (15° Max), not across.
- Choose a low ground speed so that you will not have to stop or shift while on the slope.
- Avoid starting, stopping, or turning on a slope. If the tires lose traction, disengage the blades and proceed slowly straight down the slope.
- If machine stops while going uphill, disengage blades, shift into reverse and back down slowly.
- Do not turn on slopes unless necessary, and then, turn slowly and gradually downhill, if possible.

PRODUCT SPECIFICATIONS

Gasoline Capacity and Type:	5.0 Gallons Unleaded Regular
Oil Type (API-SG-SL):	SAE 30 (above 32°F) SAE 5W-30 (below 32°F)
Oil Capacity:	W/ Filter: 4.0 Pints W/O Filter: 3.75 Pints
Spark Plug: (Gap: .040")	Champion QC12YC
Ground Speed (MPH):	Forward: 0 – 5.8 Reverse: 0 – 2.1
Tire Pressure:	Front: 14 PSI Rear: 10PSI
Charging System:	16AMPS @ 3600RPM
Battery:	Amp/Hr: 35 Min. CCA: 280 Case size: U1R
Blade Bolt Torque:	45-55 Ft. Lbs.

CONGRATULATIONS on your purchase of a new tractor. It has been designed, engineered and manufactured to give you the best possible dependability and performance.

Should you experience any problem you cannot easily remedy, please contact a Sears or other qualified service center. We have competent, well-trained technicians and the proper tools to service or repair this tractor.

Please read and retain this manual. The instructions will enable you to assemble and maintain your tractor properly. Always observe the "SAFETY RULES".

CUSTOMER RESPONSIBILITIES

- Read and observe the safety rules.
- Follow a regular schedule in maintaining, caring for and using your tractor.
- Follow the instructions under "Maintenance" and "Storage" sections of this owner's manual.

⚠ WARNING: This tractor is equipped with an internal combustion engine and should not be used on or near any unimproved forest-covered, brush-covered or grass-covered land unless the engine's exhaust system is equipped with a spark arrester meeting applicable local or state laws (if any). If a spark arrester is used, it should be maintained in effective working order by the operator.

In the state of California the above is required by law (Section 4442 of the California Public Resources Code). Other states may have similar laws. Federal laws apply on federal lands. A spark arrester for the muffler is available through your nearest Sears service center (See REPAIR PARTS section of this manual).

REPAIR PROTECTION AGREEMENTS

Congratulations on making a smart purchase. Your new Craftsman® product is designed and manufactured for years of dependable operation. But like all products, it may require repair from time to time. That's when having a Repair Protection Agreement can save you money and aggravation.

Purchase a Repair Protection Agreement now and protect yourself from unexpected hassle and expense.

Here's what's included in the Agreement:

- **Expert service** by our 12,000 professional repair specialists.
- **Unlimited service and no charge** for parts and labor on all covered repairs.
- **Product replacement** if your covered product can't be fixed.
- **Discount of 10%** from regular price of service and service-related parts not covered by the agreement; also, 10% off regular price of preventive maintenance check.
- **Fast help by phone** – phone support from a Sears technician on products requiring in-home repair, plus convenient repair scheduling.

Once you purchase the Agreement, a simple phone call is all that it takes for you to schedule service. You can call anytime day or night, or schedule a service appointment online.

Sears has over 12,000 professional repair specialists, who have access to over 4.5 million quality parts and accessories.

That's the kind of professionalism you can count on to help prolong the life of your new purchase for years to come. Purchase your Repair Protection Agreement today!

Some limitations and exclusions apply. For prices and additional information call 1-800-827-6655.

SEARS INSTALLATION SERVICE

For Sears professional installation of home appliances, garage door openers, water heaters, and other major home items, in the U.S.A. call 1-800-4-MY-HOME®

PARTS BAG CONTENTS

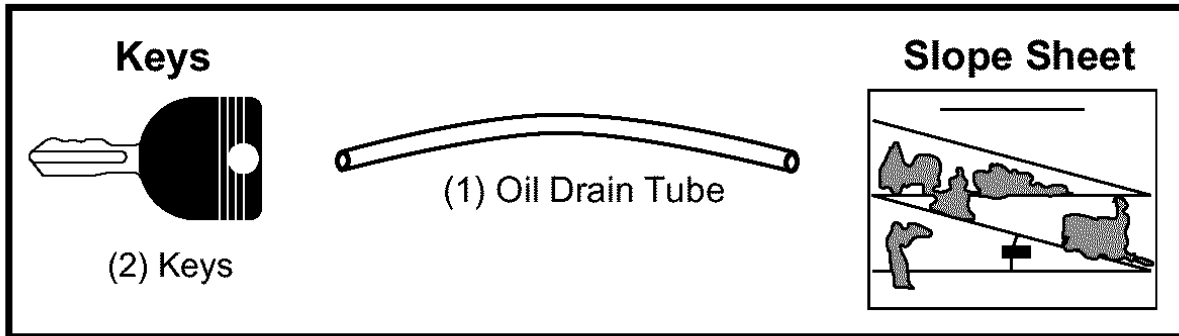

ASSEMBLY/PRE-OPERATION

Your new tractor has been assembled at the factory.

When right or left hand is mentioned in this manual, it means, from your point of view, when you are in the operating position (seated behind the steering wheel).

TO REMOVE TRACTOR FROM CARTON

UNPACK CARTON

1. Cut along dotted lines on all four panels of carton. Remove end panels and lay side panels flat.
2. Remove packing materials.
3. Remove protective materials from tractor hood and grille.

IMPORTANT: Check for and remove any staples in skid that may puncture tires where tractor is to roll off skid.

CHECK BATTERY

1. Lift hood to raised position.
- NOTE:** If this battery is put into service after month and year indicated on label (label located between terminals) charge battery for minimum of one hour at 6-10 amps. (See "BATTERY" in Maintenance section of this manual for charging instructions).

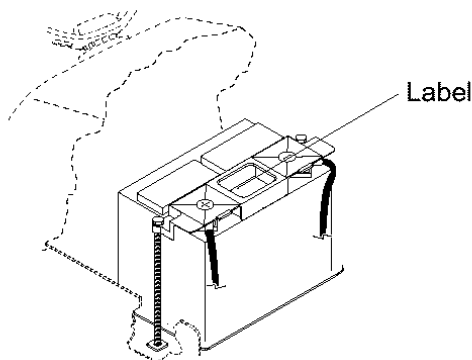

ADJUST SEAT

1. Raise seat and loosen adjustment knobs.
2. Lower seat into operating position and sit in seat.
3. Slide seat until a comfortable position is reached which allows you to press clutch/brake pedal all the way down.
4. Get off seat without moving its adjusted position.
5. Raise seat and tighten adjustment knob securely.

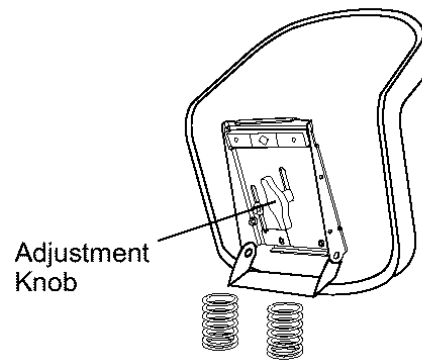

NOTE: You may now roll or drive your tractor off the skid. Follow the appropriate instruction below to remove the tractor from the skid.

TO ROLL TRACTOR OFF SKID (See Operation section for location and function of controls)

1. Press lift lever plunger and raise attachment lift lever to its highest position.
2. Release parking brake by depressing brake pedal.
3. Place freewheel control in transmission disengaged position (See "To Transport" in the Operation section of this manual).
- 7 4. Roll tractor forward off skid.

TO DRIVE TRACTOR OFF SKID (See Operation section for location and function of controls)

⚠ WARNING: Before starting, read, understand and follow all instructions in the Operation section of this manual. Be sure tractor is in a well-ventilated area. Be sure the area in front of tractor is clear of other people and objects.

1. Be sure all the above assembly steps have been completed.
2. Check engine oil level and fill fuel tank with gasoline.
3. Place freewheel control in "transmission engaged" position (See "To Transport" in the Operation section of this manual).
4. Sit on seat in operating position, depress brake pedal and set the parking brake.
5. Press lift lever plunger and raise attachment lift lever to its highest position.
6. Start the engine. After engine has started, move throttle control to idle position.
7. Release parking brake.
8. Slowly move the motion control lever forward and slowly drive tractor off skid.
9. Apply brake to stop tractor and set parking brake.
10. Turn ignition key to "STOP" position. Continue with the instructions that follow.

CHECK TIRE PRESSURE

The tires on your tractor were overinflated at the factory for shipping purposes. Correct tire pressure is important for best cutting performance.

- Reduce tire pressure to PSI shown in "PRODUCT SPECIFICATIONS" section of this manual.

CHECK DECK LEVELNESS

For best cutting results, mower housing should be properly leveled. See "TO LEVEL MOWER HOUSING" in the Service and Adjustments section of this manual.

CHECK FOR PROPER POSITION OF ALL BELTS

See the figures that are shown for replacing motion and mower blade drive belts in the Service and Adjustments section of this manual. Verify that the belts are routed correctly.

CHECK BRAKE SYSTEM

After you learn how to operate your tractor, check to see that the brake is properly adjusted. See "TO ADJUST BRAKE" in the Service and Adjustments section of this manual.

✓CHECKLIST

Before you operate your new tractor, we wish to assure that you receive the best performance and satisfaction from this Quality Product.

Please review the following checklist:

- ✓ All assembly instructions have been completed.
- ✓ No remaining loose parts in carton.
- ✓ Battery is properly prepared and charged. (Minimum 1 hour at 6 amps).
- ✓ Seat is adjusted comfortably and tightened securely.
- ✓ All tires are properly inflated. (For shipping purposes, the tires were overinflated at the factory).
- ✓ Be sure mower deck is properly leveled side-to-side/front-to-rear for best cutting results. (Tires must be properly inflated for leveling).
- ✓ Check mower and drive belts. Be sure they are routed properly around pulleys and inside all belt keepers.
- ✓ Check wiring. See that all connections are still secure and wires are properly clamped.
- ✓ Before driving tractor, be sure freewheel control is in "transmission engaged" position (see "TO TRANSPORT" in the Operation section of this manual).

While learning how to use your tractor, pay extra attention to the following important items:

- ✓ Engine oil is at proper level.
- ✓ Fuel tank is filled with fresh, clean, regular unleaded gasoline.
- ✓ Become familiar with all controls, their location and function. Operate them before you start the engine.
- ✓ Be sure brake system is in safe operating condition.
- ✓ Be sure Operator Presence System and Reverse Operation System (ROS) are working properly (See the Operation and Maintenance sections in this manual).
- ✓ It is important to purge the transmission before operating your tractor for the first time. Follow proper starting and transmission purging instructions (See "TO START ENGINE" and "PURGE TRANSMISSION" in the Operation section of this manual).

OPERATION

These symbols may appear on your tractor or in literature supplied with the product. Learn and understand their meaning.

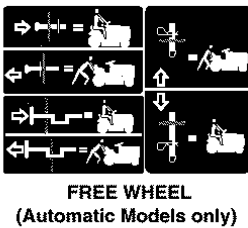
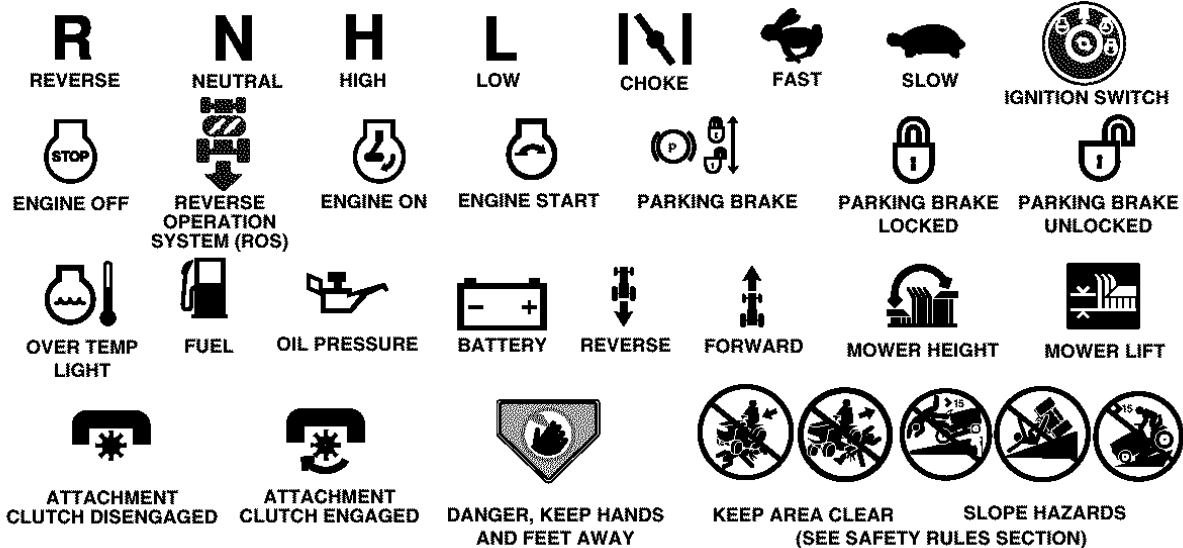

Failure to follow instructions could result in serious injury or death. The safety alert symbol is used to identify safety information about hazards which can result in death, serious injury and/or property damage.



DANGER indicates a hazard which, if not avoided, will result in death or serious injury.



WARNING indicates a hazard which, if not avoided, could result in death or serious injury.



CAUTION indicates a hazard which, if not avoided, might result in minor or moderate injury.

CAUTION when used **without** the alert symbol, indicates a situation that **could result in damage to the tractor and/or engine**.



HOT SURFACES indicates a hazard which, if not avoided, could result in death, serious injury and/or property damage.



FIRE indicates a hazard which, if not avoided, could result in death, serious injury and/or property damage.

KNOW YOUR TRACTOR

READ THIS OWNER'S MANUAL AND SAFETY RULES BEFORE OPERATING YOUR TRACTOR

Compare the illustrations with your tractor to familiarize yourself with the locations of various controls and adjustments. Save this manual for future reference.

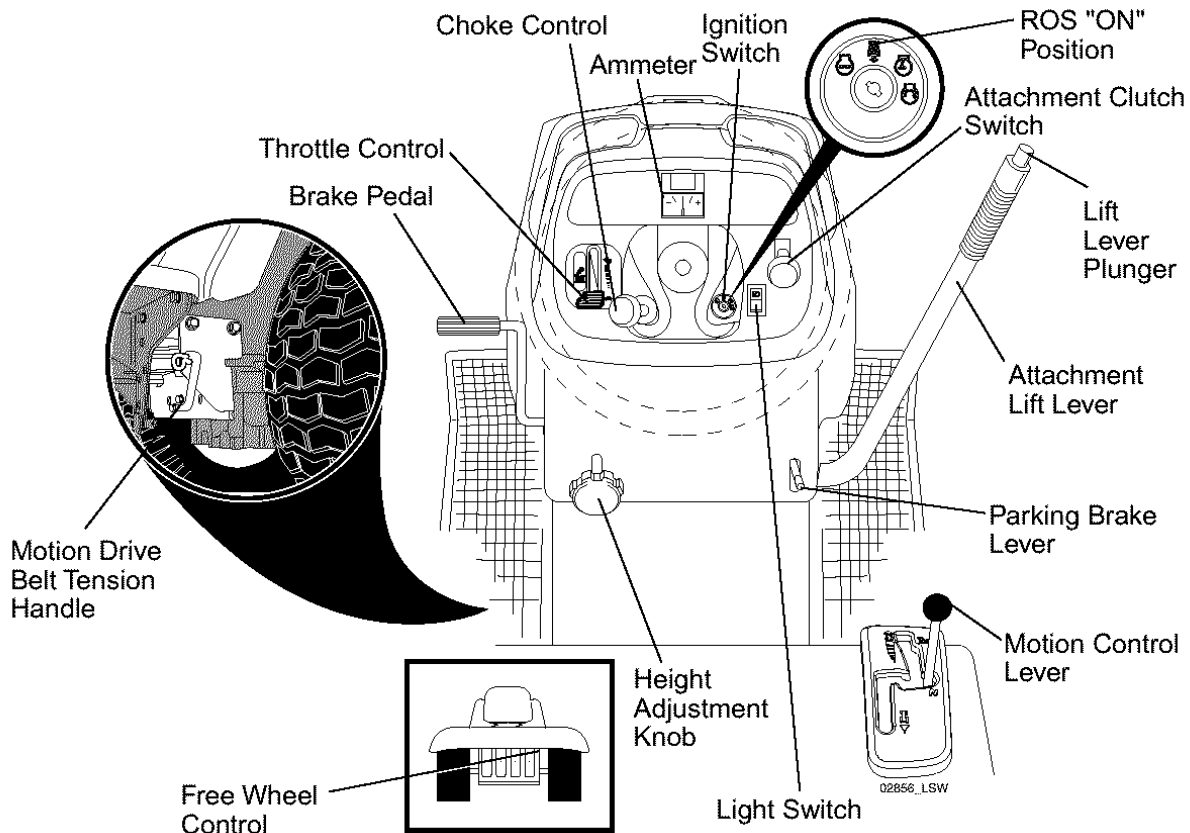

Our tractors conform to the safety standards of the
American National Standards Institute.

AMMETER - Indicates charging (+) or discharging (-) of battery.

ATTACHMENT CLUTCH SWITCH - Used to engage the mower blades, or other attachments mounted to your tractor.

ATTACHMENT LIFT LEVER - Used to raise and lower the mower deck or other attachments mounted to your tractor.

BRAKE PEDAL - Used for braking the tractor and starting the engine.

CHOKE CONTROL - Used when starting a cold engine.

FREEWHEEL CONTROL - Disengages transmission for pushing or slowly towing the tractor with the engine off.

HEIGHT ADJUSTMENT KNOB - Used to adjust the mower cutting height.

IGNITION SWITCH - Used for starting and stopping the engine.

LIFT LEVER PLUNGER - Used to release attachment lift lever when changing its position.

LIGHT SWITCH - Turns the headlights on and off.

MOTION CONTROL LEVER - Selects the speed and direction of tractor.

MOTION DRIVE BELT TENSION HANDLE - Used when changing motion drive belt and, if necessary, starting engine under extremely cold conditions.

PARKING BRAKE LEVER - Locks brake pedal into the brake position.

REVERSE OPERATION SYSTEM (ROS) "ON" POSITION - Allows operation of mower deck or other powered attachment while in reverse.

THROTTLE CONTROL - Used to control engine speed.



The operation of any tractor can result in foreign objects thrown into the eyes, which can result in severe eye damage. Always wear safety glasses or eye shields while operating your tractor or performing any adjustments or repairs. We recommend standard safety glasses or a wide vision safety mask worn over spectacles.

HOW TO USE YOUR TRACTOR TO SET PARKING BRAKE

Your tractor is equipped with an operator presence sensing switch. When engine is running, any attempt by the operator to leave the seat without first setting the parking brake will shut off the engine.

1. Depress brake pedal all the way down and hold.
2. Pull parking brake lever up and release pressure from brake pedal. Pedal should remain in brake position. Make sure parking brake will hold tractor secure.

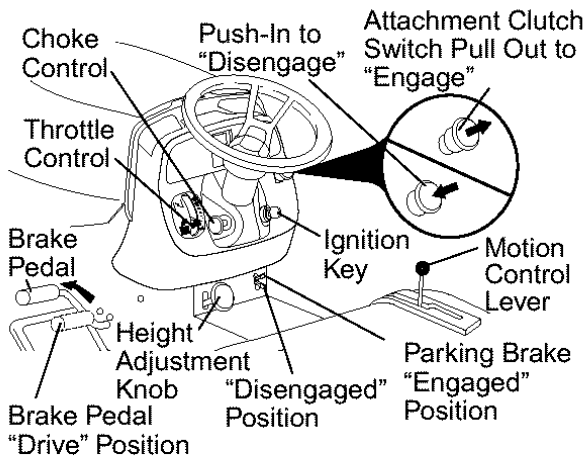

STOPPING

MOWER BLADES -

- To stop mower blades, push attachment clutch switch in to disengaged position.

GROUND DRIVE -

- To stop ground drive, depress brake pedal all the way down.

IMPORTANT: The motion control lever returns to neutral (N) position when the brake pedal is fully depressed.

ENGINE -

- Move throttle control between half and full speed (fast) position.

NOTE: Failure to move throttle control between half and full speed (fast) position, before stopping, may cause engine to "backfire".

- Turn ignition key to "STOP" position and remove key. Always remove key when leaving tractor to prevent unauthorized use.

- Never use choke to stop engine.

IMPORTANT: Leaving the ignition switch in any position other than "STOP" will cause the battery to discharge and go dead.

NOTE: Under certain conditions when tractor is standing idle with the engine running, hot engine exhaust gases may cause "browning" of grass. To eliminate this possibility, always stop engine when stopping tractor on grass areas.

CAUTION: Always stop tractor completely, as described above, before leaving the operator's position.

TO USE THROTTLE CONTROL

Always operate engine at full throttle.

- Operating engine at less than full throttle reduces the battery charging rate.
- Full throttle offers the best mower performance.

TO USE CHOKE CONTROL

Use choke control whenever you are starting a cold engine. Do not use to start a warm engine.

- To engage choke control, pull knob out. Slowly push knob in to disengage.

TO MOVE FORWARD AND BACKWARD

CAUTION: Do not attempt to operate motion control lever when the parking brake is set or when the brake pedal is depressed. Doing so may result in misadjustment to the drive control system.

The direction and speed of movement is controlled by the motion control lever.

1. Start tractor with motion control lever in neutral (N) position.
2. Release parking brake.
3. Slowly move motion control lever to desired position.

TO ADJUST MOWER CUTTING HEIGHT

The cutting height is controlled by turning the height adjustment knob in desired direction.

- Turn knob clockwise (↻) to raise cutting height.
- Turn knob counterclockwise (↺) to lower cutting height.

The cutting height range is approximately 1-1/2" to 4-1/2". The heights are measured from the ground to the blade tip with the engine not running.

These heights are approximate and may vary depending upon soil conditions, height of grass and types of grass being mowed.

- The average lawn should be cut to approximately 2-1/2 inches during the cool season and to over 3 inches during hot months. For healthier and better looking lawns, mow often and after moderate growth.
- For best cutting performance, grass over 6 inches in height should be mowed twice. Make the first cut relatively high; the second to desired height.

TO ADJUST GAUGE WHEELS

Gauge wheels are properly adjusted when they are slightly off the ground when mower is at the desired cutting height in operating position. Gauge wheels then keep the deck in proper position to help prevent scalping in most terrain conditions.

NOTE: Be sure tractor is on a flat level surface.

1. Lower mower and adjust mower to desired cutting height.
2. Remove retainer spring and clevis pin which secure each gauge wheel bar.
3. Lower gauge wheels to ground. Raise gauge wheels slightly to align holes in bracket and gauge wheel bar and insert clevis pin. Gauge wheels should be slightly off the ground.
4. Replace retainer spring into clevis pin.
5. Be sure all gauge wheels are in the same setting.

IMPORTANT: Be sure to readjust gauge wheels if you change the cutting height of the mower deck.

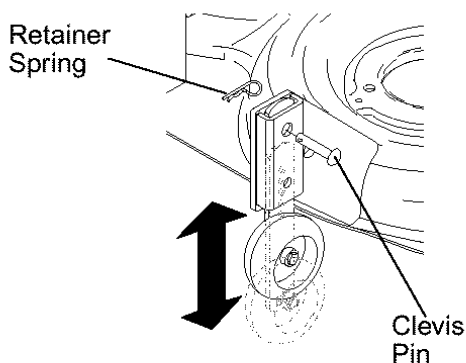

TO OPERATE MOWER

Your tractor is equipped with an operator presence sensing switch. Any attempt by the operator to leave the seat with the engine running and the attachment clutch engaged will shut off the engine. You must remain fully and centrally positioned in the seat to prevent the engine from hesitating or cutting off when operating your equipment on rough, rolling terrain or hills.

1. Select desired height of cut.
2. Lower mower with attachment lift control.
3. Start mower blades by engaging attachment clutch control.

TO STOP MOWER BLADES - disengage attachment clutch control.

CAUTION: Do not operate the mower without either the entire grass catcher, on mowers so equipped, or the deflector shield in place.

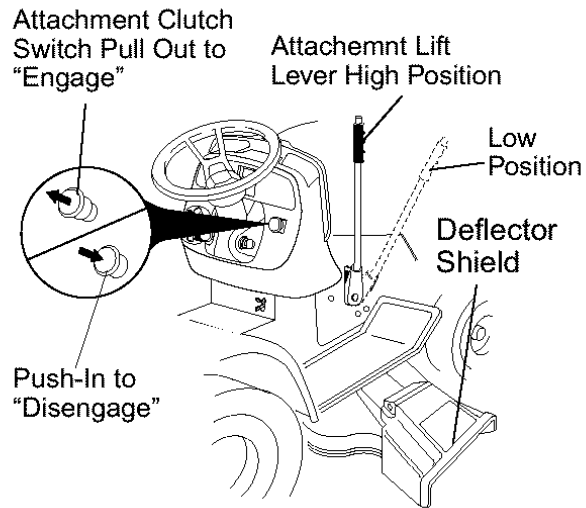

REVERSE OPERATION SYSTEM (ROS)

Your tractor is equipped with a Reverse Operation System (ROS). Any attempt by the operator to travel in the reverse direction with the attachment clutch engaged will shut off the engine unless ignition key is placed in the ROS "ON" position.

WARNING: Backing up with the attachment clutch engaged while mowing is strongly discouraged. Turning the ROS "ON", to allow reverse operation with the attachment clutch engaged, should only be done when the operator decides it is necessary to reposition the machine with the attachment engaged. **Do not mow in reverse unless absolutely necessary.**

USING THE REVERSE OPERATION SYSTEM -

1. Move motion control lever to neutral (N) position.
2. With engine running, turn ignition key counterclockwise to ROS "ON" position.
3. Look down and behind before backing.
4. Slowly move motion control lever to reverse (R) position to start movement.
5. When use of the ROS is no longer needed, turn the ignition key clockwise to engine "ON" position.

ROS "ON" Position

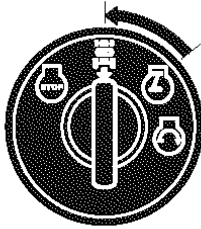

Engine "ON" Position
(Normal Operating)

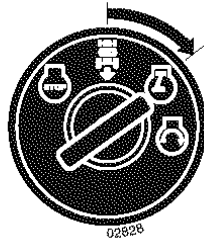

TO OPERATE ON HILLS

⚠ WARNING: Do not drive up or down hills with slopes greater than 15° and do not drive across any slope. Use the slope guide provided at the back of this manual.

- Choose the slowest speed before starting up or down hills.
- Avoid stopping or changing speed on hills.
- If stopping is absolutely necessary, push brake pedal quickly to brake position and engage parking brake.

IMPORTANT: The motion control lever returns to neutral (N) position when the brake pedal is depressed.

- To restart movement, slowly release parking brake and brake pedal.
- Slowly move motion control lever to slowest setting.
- Make all turns slowly.

TO TRANSPORT

When pushing or towing your tractor, be sure to disengage transmission by placing freewheel control in freewheeling position. Freewheel control is located at the rear drawbar of tractor.

1. Raise attachment lift to highest position with attachment lift control.
 2. Pull freewheel control out and into the slot and release so it is held in the disengaged position.
- Do not push or tow tractor at more than two (2) MPH.
 - To re-engage transmission, reverse above procedure.

Transmission Engaged

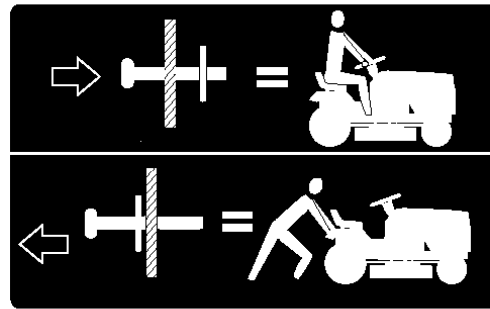

Transmission Disengaged

NOTE: To protect hood from damage when transporting your tractor on a truck or a trailer, be sure hood is closed and secured to tractor. Use an appropriate means of tying hood to tractor (rope, cord, etc.).

TOWING CARTS AND OTHER ATTACHMENTS

Tow only the attachments that are recommended by and comply with specifications of the manufacturer of your tractor. Use common sense when towing. Too heavy of a load, while on a slope, is dangerous. Tires can lose traction with the ground and cause you to lose control of your tractor.

BEFORE STARTING THE ENGINE CHECK ENGINE OIL LEVEL

The engine in your tractor has been shipped, from the factory, already filled with summer weight oil.

1. Check engine oil with tractor on level ground.
 2. Remove oil fill cap/dipstick and wipe clean, reinsert the dipstick and screw cap tight, wait for a few seconds, remove and read oil level. If necessary, add oil until "FULL" mark on dipstick is reached. Do not overfill.
- For cold weather operation you should change oil for easier starting (See the oil viscosity chart in the Maintenance section of this manual).
 - To change engine oil, see the Maintenance section in this manual.

ADD GASOLINE

- Fill fuel tank to bottom of filler neck. Do not overfill. Use fresh, clean, regular unleaded gasoline with a minimum of 87 octane. (Use of leaded gasoline will increase carbon and lead oxide deposits and reduce valve life). Do not mix oil with gasoline. Purchase fuel in quantities that can be used within 30 days to assure fuel freshness.

⚠CAUTION: Wipe off any spilled oil or fuel. Do not store, spill or use gasoline near an open flame.

IMPORTANT: When operating in temperatures below 32°F (0°C), use fresh, clean winter grade gasoline to help insure good cold weather starting.

CAUTION: Alcohol blended fuels (called gasohol or using ethanol or methanol) can attract moisture which leads to separation and formation of acids during storage. Acidic gas can damage the fuel system of an engine while in storage. To avoid engine problems, the fuel system should be emptied before storage of 30 days or longer. Drain the gas tank, start the engine and let it run until the fuel lines and carburetor are empty. Use fresh fuel next season. See Storage Instructions for additional information. Never use engine or carburetor cleaner products in the fuel tank or permanent damage may occur.

TO START ENGINE

When starting the engine for the first time or if the engine has run out of fuel, it will take extra cranking time to move fuel from the tank to the engine.

1. Be sure freewheel control is in the transmission engaged position.
2. Sit on seat in operating position, depress brake pedal and set parking brake.
3. Move attachment clutch to disengaged position.
4. Move throttle control to fast position
5. Pull choke control out for a cold engine start attempt. For a warm engine start attempt the choke control may not be needed.

NOTE: Before starting, read the warm and cold starting procedures below.

6. Insert key into ignition and turn key clockwise to start position and release key as soon as engine starts. Do not run starter continuously for more than fifteen seconds per minute. If the engine does not start after several attempts, push choke control in, wait a few minutes and try again. If engine still does not start, pull the choke control out and retry.

WARM WEATHER STARTING (50° F and above)

7. When engine starts, slowly push choke control in until the engine begins to run smoothly. If the engine starts to run roughly, pull the choke control out slightly for a few seconds and then continue to push the control in slowly.

- The attachments and ground drive can now be used. If the engine does not accept the load, restart the engine and allow it to warm up for one minute using the choke as described above.

COLD WEATHER STARTING (50° F and below)

7. When engine starts, slowly push choke control in until the engine begins to run smoothly. Continue to push the choke control in small steps allowing the engine to accept small changes in speed and load, until the choke control is fully in. If the engine starts to run roughly, pull the choke control out slightly for a few seconds and then continue to push the control in slowly. This may require an engine warm-up period from several seconds to several minutes, depending on the temperature.

NOTE: In extreme cold conditions, if engine will not start you may need to disengage the motion drive belt as follows:

1. Be sure parking brake is engaged.
2. Remove retainer spring from the drive belt tension handle to relieve belt tension.
3. Start engine and allow it to warm up for three (3) minutes.
4. Shut-off engine and engage parking brake.
5. Engage drive belt tension handle and replace the retainer spring.

AUTOMATIC TRANSMISSION WARM UP

Before driving the unit in cold weather, the transmission should be warmed up as follows:

1. Be sure the tractor is on level ground.
 2. Place the motion control lever in neutral. Release the parking brake and let the brake slowly return to operating position.
 3. Allow one minute for transmission to warm up. This can be done during the engine warm up period.
- The attachments can be used during the engine warm-up period after the transmission has been warmed up and may require the choke control be pulled out slightly.

NOTE: If at a high altitude (above 3000 feet) or in cold temperatures (below 32 F) the carburetor fuel mixture may need to be adjusted for best engine performance (see "TO ADJUST CARBURETOR" in the Service and Adjustments section of this manual).

PURGE TRANSMISSION

⚠ CAUTION: Never engage or disengage freewheel lever while the engine is running.

To ensure proper operation and performance, it is recommended that the transmission be purged before operating tractor for the first time. This procedure will remove any trapped air inside the transmission which may have developed during shipping of your tractor.

IMPORTANT: Should your transmission require removal for service or replacement, it should be purged after reinstallation before operating the tractor.

1. Place tractor safely on level surface with engine off and parking brake set.
2. Disengage transmission by placing freewheel control in disengaged position (See "TO TRANSPORT" in this section of manual).
3. Sitting in the tractor seat, start engine. After the engine is running, move throttle control to slow position. Disengage parking brake.
4. Move motion control lever to full forward position and hold for five (5) seconds. Move lever to full reverse position and hold for five (5) seconds. Repeat this procedure three (3) times.

NOTE: During this step there will be no movement of drive wheels. The air is being removed from hydraulic drive system.

5. Move motion control lever to neutral (N) position. Shutoff engine and set parking brake.
6. Engage transmission by placing freewheel control in engaged position (See "TO TRANSPORT" in this section of manual).
7. Sitting in the tractor seat, start engine. After the engine is running, move throttle control to half (1/2) speed. Disengage parking brake.
8. Slowly move motion control lever forward, after the tractor moves approximately five (5) feet, slowly move motion control lever to reverse position. After the tractor moves approximately five (5) feet return the motion control lever to the neutral (N) position. Repeat this procedure with the motion control lever three (3) times.

Your transmission is now purged and now ready for normal operation.

MOWING TIPS

- Tire chains cannot be used when the mower housing is attached to tractor.
- Mower should be properly leveled for best mowing performance. See "TO LEVEL MOWER HOUSING" in the Service and Adjustments section of this manual.
- The left hand side of mower should be used for trimming.
- Drive so that clippings are discharged onto the area that has already been cut. Have the cut area to the right of the tractor. This will result in a more even distribution of clippings and more uniform cutting.
- When mowing large areas, start by turning to the right so that clippings will discharge away from shrubs, fences, driveways, etc. After one or two rounds, mow in the opposite direction making left hand turns until finished.

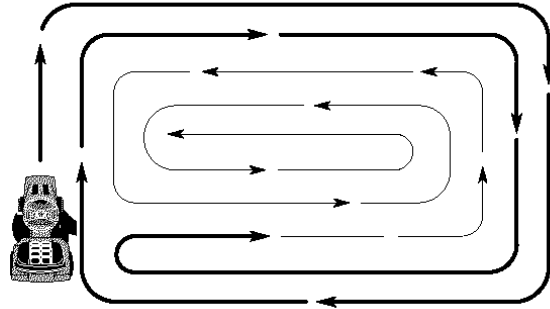

- If grass is extremely tall, it should be mowed twice to reduce load and possible fire hazard from dried clippings. Make first cut relatively high; the second to the desired height.
- Do not mow grass when it is wet. Wet grass will plug mower and leave undesirable clumps. Allow grass to dry before mowing.
- **Always operate engine at full throttle when mowing** to assure better mowing performance and proper discharge of material. Regulate ground speed by selecting a low enough gear to give the mower cutting performance as well as the quality of cut desired.
- When operating attachments, select a ground speed that will suit the terrain and give best performance of the attachment being used.

MAINTENANCE

MAINTENANCE SCHEDULE		FILL IN DATES AS YOU COMPLETE REGULAR SERVICE					SERVICE DATES			
		BEFORE EACH USE	EVERY 8 HOURS	EVERY 25 HOURS	EVERY 50 HOURS	EVERY 100 HOURS	EVERY SEASON	BEFORE STORAGE		
T R A C T O R	Check Brake Operation	✓	✓							
	Check Tire Pressure	✓	✓							
	Check Operator Presence and ROS Systems	✓								
	Check for Loose Fasteners	✓			✓ ₅		✓			
	Sharpen/Replace Mower Blades			✓ ₃						
	Lubrication Chart			✓			✓			
	Check Battery Level			✓ ₄						
	Clean Battery and Terminals			✓			✓			
	Check Transaxle Cooling			✓						
	Check V-Belts					✓				
E N G I N E	Check Engine Oil Level	✓	✓							
	Change Engine Oil (with oil filter)				✓ _{1,2}		✓			
	Change Engine Oil (without oil filter)			✓ _{1,2}			✓			
	Clean Air Filter			✓ ₂						
	Clean Air Screen			✓ ₂						
	Inspect Muffler/Spark Arrester				✓					
	Replace Oil Filter (If equipped)					✓ _{1,2}				
	Clean Engine Cooling Fins					✓ ₂				
	Replace Spark Plug					✓	✓			
	Replace Air Filter Paper Cartridge					✓ ₂				
Replace Fuel Filter							✓			

1 - Change more often when operating under a heavy load or in high ambient temperatures.
 2 - Service more often when operating in dirty or dusty conditions.

3 - Replace blades more often when mowing in sandy soil.
 4 - Not required if equipped with maintenance-free battery.
 5 - Tighten front axle pivot bolt to 35 ft.-lbs. maximum. Do not overtighten.

© 2005 Schaefer POS

GENERAL RECOMMENDATIONS

The warranty on this tractor does not cover items that have been subjected to operator abuse or negligence. To receive full value from the warranty, operator must maintain tractor as instructed in this manual.

Some adjustments will need to be made periodically to properly maintain your tractor.

At least once a season, check to see if you should make any of the adjustments described in the Service and Adjustments section of this manual.

- At least once a year you should replace the spark plug, clean or replace air filter, and check blades and belts for wear. A new spark plug and clean air filter assure proper air-fuel mixture and help your engine run better and last longer.

BEFORE EACH USE

- Check engine oil level.
- Check brake operation.
- Check tire pressure.
- Check operator presence and ROS systems for proper operation.
- Check for loose fasteners.

LUBRICATION CHART

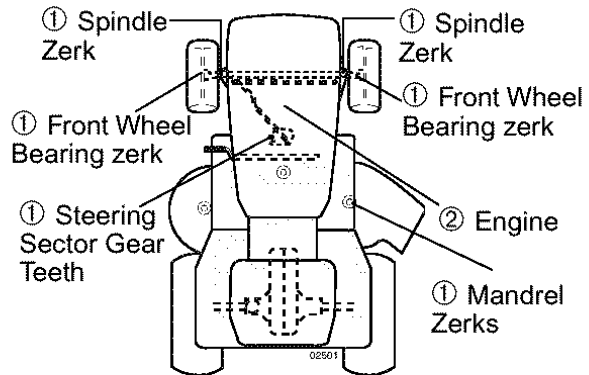

- ① General Purpose Grease
- ② Refer to Maintenance "ENGINE" Section

IMPORTANT: Do not oil or grease the pivot points which have special nylon bearings. Viscous lubricants will attract dust and dirt that will shorten the life of the self-lubricating bearings. If you feel they must be lubricated, use only a dry, powdered graphite type lubricant sparingly.

TRACTOR

Always observe safety rules when performing any maintenance.

BRAKE OPERATION

If tractor requires more than five (5) feet to stop at highest speed in highest gear on a level, dry concrete or paved surface, then brake must be checked and adjusted. (See "TO ADJUST BRAKE" in the Service and Adjustments section of this manual).

TIRES

- Maintain proper air pressure in all tires (See "PRODUCT SPECIFICATIONS" section of this manual).
- Keep tires free of gasoline, oil, or insect control chemicals which can harm rubber.
- Avoid stumps, stones, deep ruts, sharp objects and other hazards that may cause tire damage.

NOTE: To seal tire punctures and prevent flat tires due to slow leaks, tire sealant may be purchased from your local parts dealer. Tire sealant also prevents tire dry rot and corrosion.

OPERATOR PRESENCE SYSTEM AND REVERSE OPERATION SYSTEM (ROS)

Be sure operator presence and reverse operation systems are working properly. If your tractor does not function as described, repair the problem immediately.

- The engine should not start unless the brake pedal is fully depressed, and the attachment clutch control is in the disengaged position.

CHECK OPERATOR PRESENCE SYSTEM

- When the engine is running, any attempt by the operator to leave the seat without first setting the parking brake should shut off the engine.
- When the engine is running and the attachment clutch is engaged, any attempt by the operator to leave the seat should shut off the engine.
- The attachment clutch should never operate unless the operator is in the seat.

ROS "ON" Position

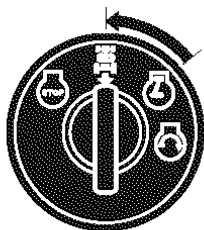

Engine "ON" Position (Normal Operating)

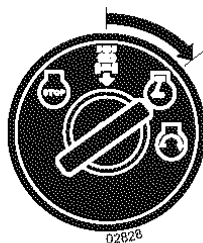

CHECK REVERSE OPERATION (ROS) SYSTEM

- When the engine is running with the ignition switch in the engine "ON" position and the attachment clutch engaged, any attempt by the operator to shift into reverse should shut off the engine.
- When the engine is running with the ignition switch in the ROS "ON" position and the attachment clutch engaged, any attempt by the operator to shift into reverse should NOT shut off the engine.

BLADE CARE

For best results mower blades must be kept sharp. Replace bent or damaged blades.

CAUTION: Use only a replacement blade approved by the manufacturer of your tractor. Using a blade not approved by the manufacturer of your tractor is hazardous, could damage your tractor and void your warranty.

BLADE REMOVAL

1. Raise mower to highest position to allow access to blades.

NOTE: Protect your hands with gloves and/or wrap blade with heavy cloth.

2. Remove blade bolt by turning counter-clockwise.
3. Install new or resharpened blade with stamped "THIS SIDE UP" facing deck and mandrel assembly.

IMPORTANT: To ensure proper assembly, center hole in blade must align with star on mandrel assembly.

4. Install and tighten blade bolt securely (45-55 Ft. Lbs. torque).

IMPORTANT: Special blade bolt is heat treated.

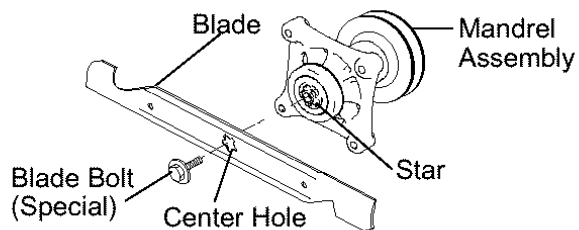

TO SHARPEN BLADE

NOTE: We do not recommend sharpening blade - but if you do, be sure the blade is balanced.

Care should be taken to keep the blade balanced. An unbalanced blade will cause excessive vibration and eventual damage to mower and engine.

- The blade can be sharpened with a file or on a grinding wheel. Do not attempt to sharpen while on the mower.

- To check blade balance, you will need a 5/8" diameter steel bolt, pin, or a cone balancer. (When using a cone balancer, follow the instructions supplied with balancer.)

- NOTE:** Do not use a nail for balancing blade. The lobes of the center hole may appear to be centered, but are not.
- Slide blade on to an unthreaded portion of the steel bolt or pin and hold the bolt or pin parallel with the ground. If blade is balanced, it should remain in a horizontal position. If either end of the blade moves downward, sharpen the heavy end until the blade is balanced.

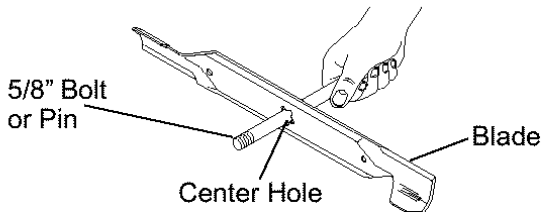

BATTERY

Your tractor has a battery charging system which is sufficient for normal use. However, periodic charging of the battery with an automotive charger will extend its life.

- Keep battery and terminals clean.
- Keep battery bolts tight.
- Keep small vent holes open.
- Recharge at 6-10 amperes for 1 hour.

NOTE: The original equipment battery on your tractor is maintenance free. Do not attempt to open or remove caps or covers. Adding or checking level of electrolyte is not necessary.

TO CLEAN BATTERY AND TERMINALS

Corrosion and dirt on the battery and terminals can cause the battery to "leak" power.

1. Remove terminal guard.
2. Disconnect BLACK battery cable first then RED battery cable and remove battery from tractor.
3. Rinse the battery with plain water and dry.
4. Clean terminals and battery cable ends with wire brush until bright.
5. Coat terminals with grease or petroleum jelly.
6. Reinstall battery (See "REPLACING BATTERY" in the SERVICE AND ADJUSTMENTS section of this manual).

TRANSAXLE COOLING

The transmission fan and cooling fins should be kept clean to assure proper cooling.

Do not attempt to clean fan or transmission while engine is running or while the transmission is hot. To prevent possible damage to seals, do not use high pressure water or steam to clean transaxle.

- Inspect cooling fan to be sure fan blades are intact and clean.
- Inspect cooling fins for dirt, grass clippings and other materials. To prevent damage to seals, do not use compressed air or high pressure sprayer to clean cooling fins.

TRANSAXLE PUMP FLUID

The transaxle was sealed at the factory and fluid maintenance is not required for the life of the transaxle. Should the transaxle ever leak or require servicing, contact a Sears or other qualified service center.

V-BELTS

Check V-belts for deterioration and wear after 100 hours of operation and replace if necessary. The belts are not adjustable. Replace belts if they begin to slip from wear.

ENGINE

LUBRICATION

Only use high quality detergent oil rated with API service classification SG-SL. Select the oil's SAE viscosity grade according to your expected operating temperature.

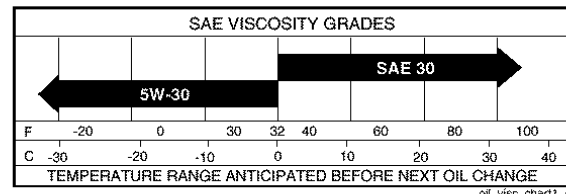

NOTE: Although multi-viscosity oils (5W30, 10W30 etc.) improve starting in cold weather, they will result in increased oil consumption when used above 32°F. Check your engine oil level more frequently to avoid possible engine damage from running low on oil.

Change the oil after every 50 hours of operation or at least once a year if the tractor is not used for 50 hours in one year.

Check the crankcase oil level before starting the engine and after each eight (8) hours of operation. Tighten oil fill cap/dipstick securely each time you check the oil level.

TO CHANGE ENGINE OIL

Determine temperature range expected before oil change. All oil must meet API service classification SG-SL.

- Be sure tractor is on level surface.
 - Oil will drain more freely when warm.
 - Catch oil in a suitable container.
1. Remove oil fill cap/dipstick. Be careful not to allow dirt to enter the engine when changing oil.
 2. Install the drain tube onto the valve.

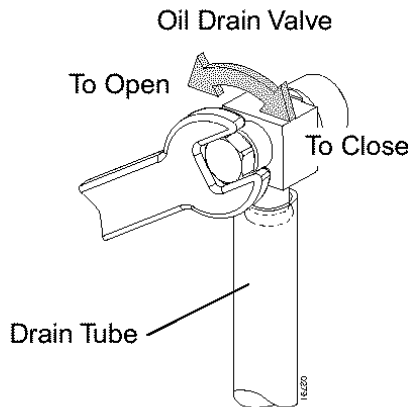

3. Open drain valve by using a 7/16" (11mm) wrench turning counterclockwise.
4. After oil has drained completely, close the drain valve turning clockwise. Use the 7/16" (11mm) wrench to apply a small amount of torque to keep it closed. Do not over tighten.
5. Remove the drain tube and store in a safe place.
6. Refill engine with oil through oil fill dipstick tube. Pour slowly. Do not overfill. For approximate capacity see "PRODUCT SPECIFICATIONS" section of this manual.
7. Use gauge on oil fill cap/dipstick for checking level. For accurate reading, tighten dipstick cap securely onto the tube before removing dipstick. Keep oil at "FULL" line on dipstick. Tighten cap onto the tube securely when finished.

ENGINE OIL FILTER

Replace the engine oil filter every season or every other oil change if the tractor is used more than 100 hours in one year.

AIR FILTER

Your engine will not run properly using a dirty air filter. Clean the foam pre-cleaner after every 25 hours of operation or every season. Service paper cartridge every 100 hours of operation or every season, whichever occurs first.

Service air cleaner more often under dusty conditions.

1. Remove cover.

TO SERVICE PRE-CLEANER

2. Wash it in liquid detergent and water.
3. Squeeze it dry in a clean cloth.
4. Saturate it in engine oil. Wrap it in clean, absorbent cloth and squeeze to remove excess oil.

NOTE: If very dirty or damaged, replace pre-cleaner.

TO SERVICE CARTRIDGE

1. Clean cartridge by tapping gently on flat surface. If very dirty or damaged, replace cartridge.
2. Reinstall precleaner cartridge, cover and secure.

IMPORTANT: Petroleum solvents, such as kerosene, are not to be used to clean the cartridge. They may cause deterioration of the cartridge. Do not oil cartridge. Do not use pressurized air to clean or dry cartridge.

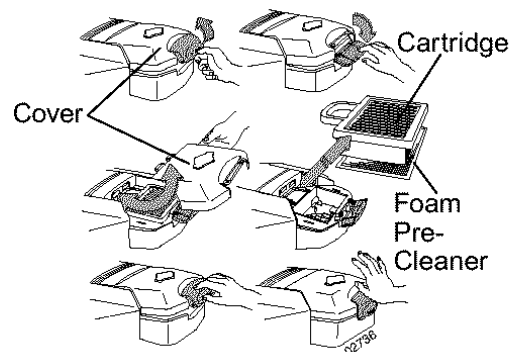

CLEAN AIR SCREEN

Air screen must be kept free of dirt and chaff to prevent engine damage from overheating. Clean with a wire brush or compressed air to remove dirt and stubborn dried gum fibers.

CLEAN AIR INTAKE/COOLING AREAS

To insure proper cooling, make sure the grass screen, cooling fins, and other external surfaces of the engine are kept clean at all times.

Every 100 hours of operation (more often under extremely dusty, dirty conditions), remove the blower housing and other cooling shrouds. Clean the cooling fins and external surfaces as necessary. Make sure the cooling shrouds are reinstalled.

NOTE: Operating the engine with a blocked grass screen, dirty or plugged cooling fins, and/or cooling shrouds removed will cause engine damage due to overheating.

MUFFLER

Inspect and replace corroded muffler and spark arrester (if equipped) as it could create a fire hazard and/or damage.

SPARK PLUG(S)

Replace spark plug(s) at the beginning of each mowing season or after every 100 hours of operation, whichever occurs first. Spark plug type and gap setting are shown in "PRODUCT SPECIFICATIONS" section of this manual.

IN-LINE FUEL FILTER

The fuel filter should be replaced once each season. If fuel filter becomes clogged, obstructing fuel flow to carburetor, replacement is required.

1. With engine cool, remove filter and plug fuel line sections.
2. Place new fuel filter in position in fuel line with arrow pointing towards carburetor.
3. Be sure there are no fuel line leaks and clamps are properly positioned.
4. Immediately wipe up any spilled gasoline.

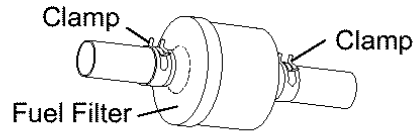

CLEANING

- Clean engine, battery, seat, finish, etc. of all foreign matter.
- Keep finished surfaces and wheels free of all gasoline, oil, etc.
- Protect painted surfaces with automotive type wax.

We do not recommend using a garden hose or pressure washer to clean your tractor unless the engine and transmission are covered to keep water out. Water in engine or transmission will shorten the useful life of your tractor. Use compressed air or a leaf blower to remove grass, leaves and trash from tractor and mower.

SERVICE AND ADJUSTMENTS



WARNING: TO AVOID SERIOUS INJURY, BEFORE PERFORMING ANY SERVICE OR ADJUSTMENTS:

1. Depress brake pedal fully and set parking brake.
2. Place attachment clutch in "DISENGAGED" position.
3. Turn ignition key to "STOP" and remove key.
4. Make sure the blades and all moving parts have completely stopped.
5. Disconnect spark plug wire from spark plug and place wire where it cannot come in contact with plug.

TRACTOR

TO REMOVE MOWER

1. Place attachment clutch in "DISENGAGED" position.
2. If equipped, turn height adjustment knob to lowest setting.
3. Lower mower to its lowest position.
4. Disengage belt tension rod from lock bracket.
- ⚠ **CAUTION:** Rod is spring loaded. Have a tight grip on rod and release slowly.
5. Remove retainer spring holding anti-swaybar to chassis bracket and disengage anti-swaybar from bracket.
6. Remove four retainer springs from front plate assembly and remove plate.
7. Remove retainer springs from suspension arms at deck and disengage arms from deck.
8. Raise attachment lift to its highest position.
9. Slide mower forward and remove belt from electric clutch pulley.
10. Slide mower out from under right side of tractor.

TO INSTALL MOWER

Be sure tractor is on level surface and mower suspension arms are raised with attachment lift control. Engage parking brake.

1. Swing anti-sway bar to left side of mower deck.
2. Slide mower under tractor with deflector shield to right side of tractor.
- IMPORTANT:** Check belt for proper routing in all mower pulley grooves.
3. If equipped, turn height adjustment knob counterclockwise until it stops.
4. Lower mower linkage with attachment lift control.
5. Be sure belt tension rod is in disengaged position.
6. Install belt into electric clutch pulley groove.
7. Place the suspension arms on outward pointing deck pins. Retain with double loop retainer spring with loops up as shown.
8. Install front plate assembly to tractor suspension brackets and retain with single loop retainer springs as shown.

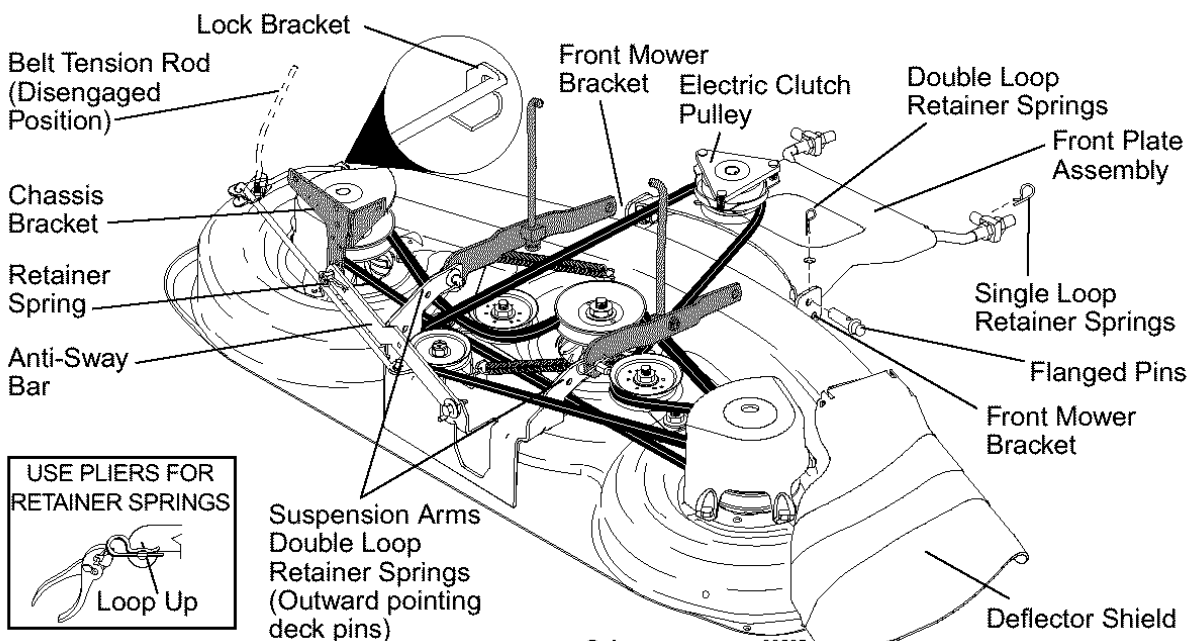

9. Position front plate assembly between front mower brackets. Raise deck and plate assembly to align holes and insert flanged pins. Secure pins with double loop retainer springs between the plate assembly and mower brackets.

NOTE: To assist in locating hole in flanged pin, the hole in pin is inline with notch on head of pin. If necessary, move mower side-to-side to give space between plate and mower brackets.

IMPORTANT: Check belt for proper routing in all mower pulley grooves.

10. Engage belt tension rod by pushing rod into locking bracket.

CAUTION: Belt tension rod is spring loaded. Have a tight grip on rod and engage slowly.

11. Connect anti-sway bar to chassis bracket under left footrest and retain with double loop retainer spring.
12. If equipped, turn height adjustment knob clockwise to remove slack from mower suspension.
13. Raise deck to highest position.

TO LEVEL MOWER HOUSING

Adjust the mower while tractor is parked on level ground or driveway. Make sure tires are properly inflated (See "PRODUCT SPECIFICATIONS" section of this manual). If tires are over or underinflated, you will not properly adjust your mower.

SIDE-TO-SIDE ADJUSTMENT

- Raise mower to its highest position.
- Measure height from bottom edge of mower to ground level at front corners of mower. Distance "A" on both sides of mower should be the same.
- If adjustment is necessary, make adjustment on one side of mower only.
- To raise one side of mower, tighten lift link adjustment nut on that side.
- To lower one side of mower, loosen lift link adjustment nut on that side.

NOTE: Each full turn of adjustment nut will change mower height about 3/16".

- Recheck measurements after adjusting.

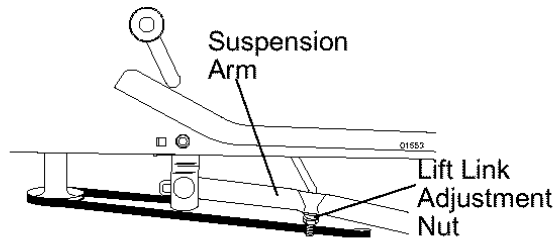
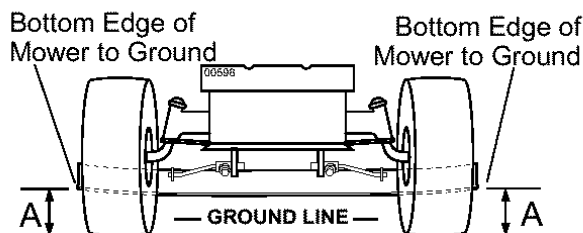

FRONT-TO-BACK ADJUSTMENT

IMPORTANT: Deck must be level side-to-side. If the following front-to-back adjustment is necessary, be sure to adjust both front links equally so mower will stay level side-to-side.

To obtain the best cutting results, the mower blades should be adjusted so the front tip is approximately 1/8" to 1/2" lower than the rear tip when the mower is in its highest position.

CAUTION: Blades are sharp. Protect your hands with gloves and/or wrap blade with heavy cloth.

Check adjustment on right side of tractor. Position any blade so the tip is pointing straight forward. Measure distance "B" at front and rear tip of blade

- Before making any necessary adjustments, check that both front plate links are equal in length.
- If links are not equal in length, adjust one link to same length as other link.
- To lower front of blade, loosen nut "C" on both front links an equal number of turns.

NOTE: Each full turn of nut "C" will change distance "B" by approximately 3/16".

- When distance "B" is 1/8" to 1/2" lower at front than rear, tighten nut "D" against trunnion on both front links.
- To raise front of blade, loosen nut "D" from trunnion on both front links. Tighten nut "C" on both front links an equal number of turns. The two front links must remain equal in length.
- When distance "B" is 1/8" to 1/2" lower at front than rear, tighten nut "D" against trunnion on both front links.
- Recheck side-to-side adjustment.

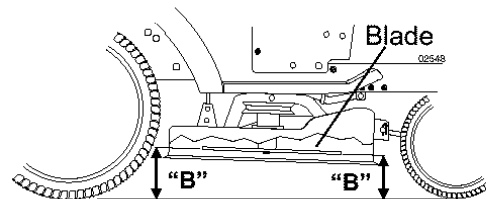

BOTH FRONT PLATE LINKS MUST BE EQUAL IN LENGTH

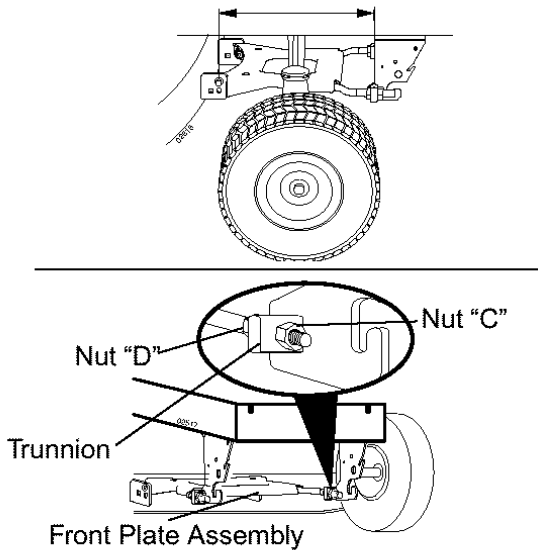

TO REPLACE MOWER DRIVE BELT

MOWER DRIVE BELT REMOVAL

1. Park tractor on a level surface. Engage parking brake.
2. Lower mower to its lowest position.
3. Disengage belt tension rod from lock bracket.

CAUTION: Rod is spring loaded. Have a firm grip on rod and release slowly.

4. Remove screws from R.H. mandrel cover and remove cover.

5. Remove any dirt or grass clippings which may have accumulated around mandrels and entire upper deck surface.
6. Disconnect R.H. suspension arm from rear deck bracket by removing retainer spring.
7. Carefully roll belt over the top of R.H. mandrel pulley.
8. Remove belt from electric clutch pulley.
9. Remove belt from idler pulleys.
10. Check primary idler arm and two idlers to see that they rotate freely.
11. Be sure spring is securely hooked to primary idler arm and spring arm.

MOWER DRIVE BELT INSTALLATION

12. Install belt in both idlers.
13. Install new belt onto electric clutch pulley.
14. Carefully roll belt into upper groove of R.H. mandrel pulley.
15. Carefully check belt routing making sure belt is in the grooves correctly.
16. Reconnect R.H. suspension arm to rear deck bracket with retainer spring.
17. Reassemble R.H. mandrel cover.
18. Engage belt tension rod by pushing rod into locking bracket.

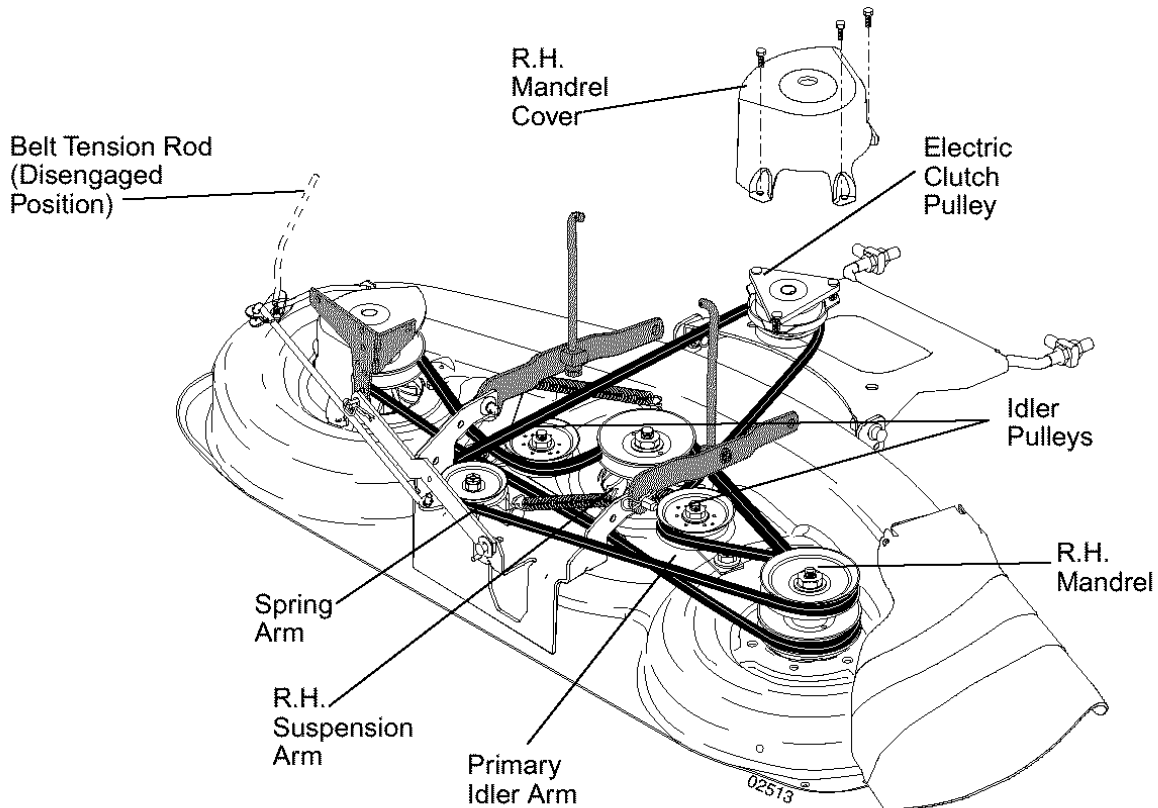

TO REPLACE MOWER BLADE (SECONDARY) DRIVE BELT

Park the tractor on level surface. Engage parking brake.

1. Remove mower (See "TO REMOVE MOWER" in this section of manual).
2. Remove screws from R.H. and L.H. mandrel covers and remove covers.

REMOVE MOWER DRIVE BELT

(Refer to "TO REMOVE MOWER DRIVE BELT" illustration in this section of manual).

3. Carefully roll belt over the top of R.H. mandrel pulley.
4. Remove belt from idler pulleys.
5. Check primary idler arm and two idlers to see that they rotate freely.
6. Be sure spring is securely hooked to primary idler arm and spring arm.

REMOVE MOWER BLADE (SECONDARY) DRIVE BELT

7. Carefully roll belt off L.H. mandrel pulley.
8. Remove belt from center mandrel pulley, idler pulley, and R.H. mandrel pulley.
9. Remove any dirt or grass which may have accumulated around mandrels and entire upper deck surface.

10. Check secondary idler arm and idler pulley to see that they rotate freely.
11. Be sure spring is hooked in secondary idler arm and secondary spring arm.

INSTALL NEW MOWER BLADE (SECONDARY) DRIVE BELT

12. Install new belt in lower groove of R.H. mandrel pulley, idler pulley, and center mandrel pulley as shown.
13. Carefully roll belt over L.H. mandrel pulley. Make sure belt is in all grooves properly.

REINSTALL MOWER DRIVE BELT

(Refer to "TO REMOVE MOWER DRIVE BELT" illustration in this section of manual).

14. Install belt into upper groove of R.H. mandrel pulley and around both idlers. Pull belt to front of mower to remove slack.
15. Reinstall mandrel covers and securely tighten all screws.
16. Carefully check belt routing making sure belt is in all grooves correctly.
17. Reinstall mower to tractor (See "TO INSTALL MOWER" in this section of manual).

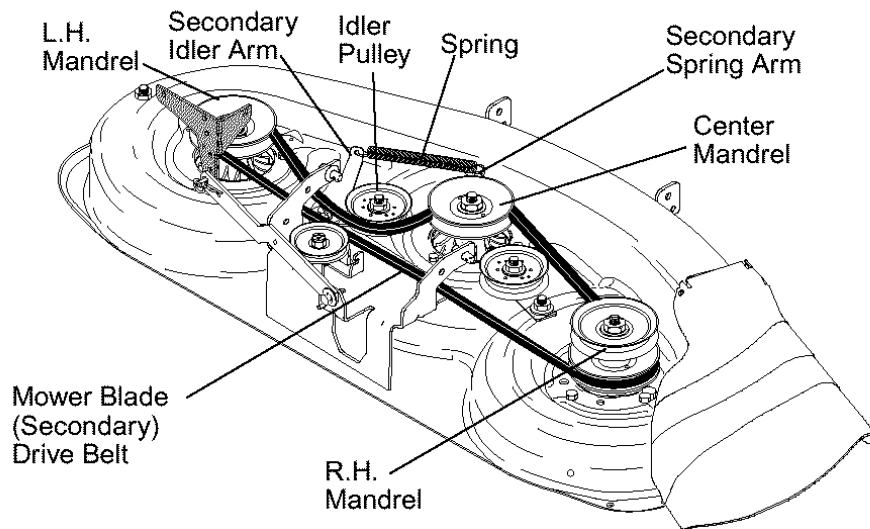

TO ADJUST ATTACHMENT CLUTCH

The electric clutch should provide years of service. The clutch has a built-in brake that stops the pulley within 5 seconds. Eventually, the internal brake will wear which may cause the mower blades to not engage, or, to not stop as required. Adjustments should be made by a Sears or other qualified service center.

1. Make sure attachment clutch and ignition switches are in "OFF" position.
2. Adjust the three nylon locknuts until space between clutch plate and rotor measures .012" at all three slot locations cut in the side of brake plate.

NOTE: After installing a new electric clutch, run tractor at full throttle and engage and disengage electric clutch 10 cycles to wear in clutch plate.

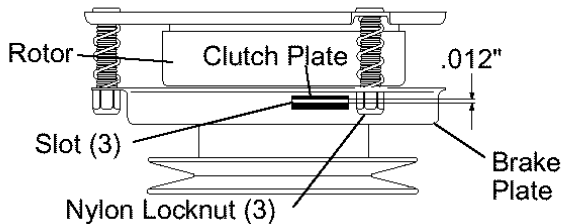

TO CHECK AND ADJUST BRAKE

If tractor requires more than five (5) feet to stop at highest speed in highest gear on a level, dry concrete or paved surface, then brake must be checked and adjusted.

TO CHECK BRAKE

1. Park tractor on a level, dry concrete or paved surface, depress clutch/brake pedal all the way down and engage parking brake.
2. Disengage transmission by placing freewheel control in "transmission disengaged" position. Pull freewheel control out and into the slot and release so it is held in the disengaged position.

The rear wheels must lock and skid when you try to manually push the tractor forward. If the rear wheels rotate, the brake needs to be adjusted or the pads need to be replaced.

TO ADJUST BRAKE

Contact a Sears or other qualified service center.

TO REPLACE MOTION DRIVE BELT

Park the tractor on level surface. Engage parking brake. For ease of service there is a belt installation guide decal on bottom of left footrest.

1. Remove mower (See "TO REMOVE MOWER" in this section of this manual.)

BELT REMOVAL -

2. Create slack in belt by removing retainer spring from drive belt tension handle.
3. Remove belt from all idler pulleys, transaxle pulley and then from engine pulley.

BELT INSTALLATION -

1. Install new belt around engine pulley first, then around transaxle pulley and lastly into all the idler pulleys.
2. Check to be sure belt is positioned correctly and is on proper side of all belt keepers.
3. Engage the drive belt tension handle and replace the retainer spring.
4. Reinstall mower.

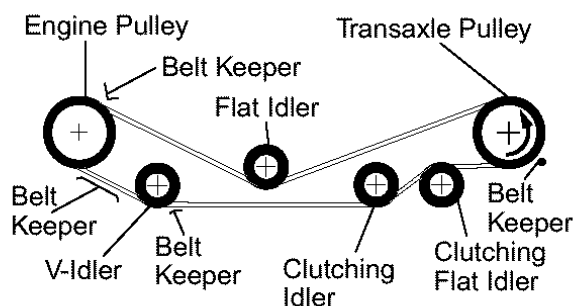
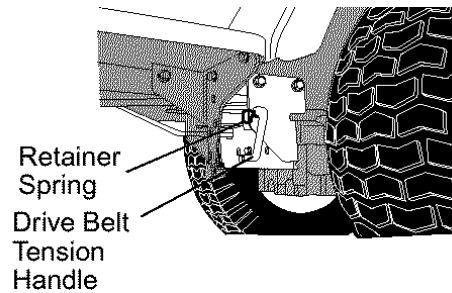

TRANSAXLE MOTION CONTROL LEVER NEUTRAL ADJUSTMENT

The motion control lever has been preset at the factory and adjustment should not be necessary.

1. Park Tractor on level surface. Stop tractor by turning ignition key to "OFF" position and engage parking brake.
2. Loosen the adjustment bolt in front of the right rear wheel.
3. Move motion control lever to the neutral position.
4. Tighten the adjustment bolt.

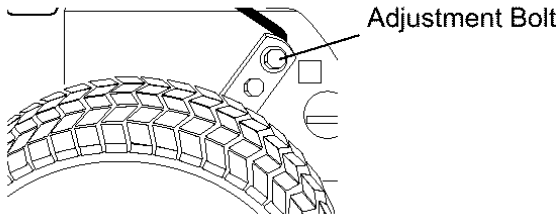

TRANSMISSION REMOVAL/REPLACEMENT

Should your transmission require removal for service or replacement, it should be purged after reinstallation and before operating the tractor. See "PURGE TRANSMISSION" in the Operation section of this manual.

TO ADJUST STEERING WHEEL ALIGNMENT

If steering wheel crossbars are not horizontal (left to right) when wheels are positioned straight forward, remove steering wheel and reassemble with crossbars horizontal. Tighten securely.

FRONT WHEEL TOE-IN/CAMBER

The front wheel toe-in and camber are not adjustable on your tractor. If damage has occurred to affect the front wheel toe-in or camber, contact a Sears or other qualified service center.

TO REMOVE WHEEL FOR REPAIRS

FRONT WHEEL -

1. Block up axle securely.
2. Remove axle cover, retaining ring and washers to allow wheel removal.
3. Repair tire and reassemble.
4. Replace washers and snap retaining ring securely in axle groove.
5. Replace axle cover.

REAR WHEEL -

1. Block rear axle securely.
2. Remove five (5) hub bolts to allow wheel removal.
3. Repair tire and reassemble. Replace and tighten hub bolts securely.

NOTE: To seal tire punctures and prevent flat tires due to slow leaks, purchase and use tire sealant from Sears. Tire sealant also prevents tire dry rot and corrosion.

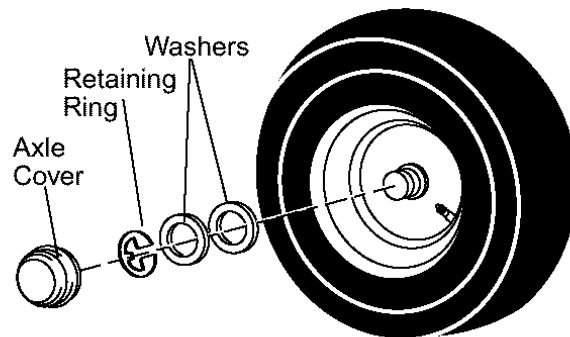

TO START ENGINE WITH A WEAK BATTERY

WARNING: Lead-acid batteries generate explosive gases. Keep sparks, flame and smoking materials away from batteries. Always wear eye protection when around batteries.

If your battery is too weak to start the engine, it should be recharged. (See "BATTERY" in the MAINTENANCE section of this manual).

If "jumper cables" are used for emergency starting, follow this procedure:

IMPORTANT: Your tractor is equipped with a 12 volt system. The other vehicle must also be a 12 volt system. Do not use your tractor battery to start other vehicles.

TO ATTACH JUMPER CABLES -

1. Connect one end of the RED cable to the POSITIVE (+) terminal of each battery(A-B), taking care not to short against tractor chassis.
2. Connect one end of the BLACK cable to the NEGATIVE (-) terminal (C) of fully charged battery.

3. Connect the other end of the BLACK cable (D) to good chassis ground, away from fuel tank and battery.

TO REMOVE CABLES, REVERSE ORDER -

1. BLACK cable first from chassis and then from the fully charged battery.
2. RED cable last from both batteries.

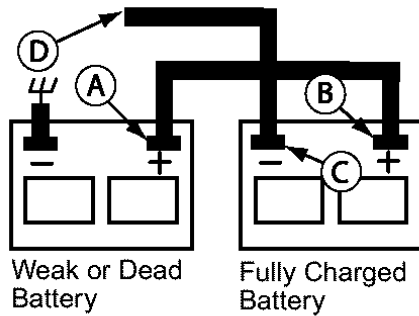

REPLACING BATTERY

⚠ WARNING: Do not short battery terminals by allowing a wrench or any other object to contact both terminals at the same time. Before connecting battery, remove metal bracelets, wristwatch bands, rings, etc.

Positive terminal must be connected first to prevent sparking from accidental grounding.

1. Lift hood to raised position.
2. Remove terminal guard.
3. Disconnect BLACK battery cable then RED battery cable and carefully remove battery from tractor.
4. Install new battery with terminals in same position as old battery.
5. Reinstall terminal guard.
6. First connect RED battery cable to positive (+) battery terminal with hex bolt and keps nut as shown. Tighten securely.
7. Connect BLACK grounding cable to negative (-) battery terminal with remaining hex bolt and keps nut. Tighten securely.
8. Close terminal access doors.
9. Close hood.

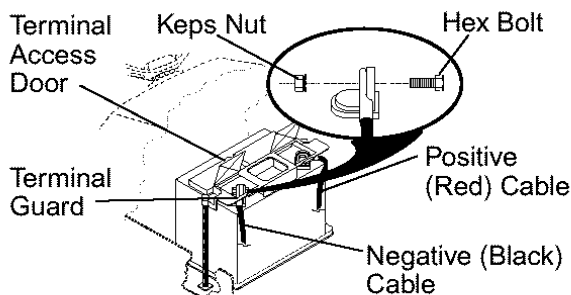

TO REPLACE HEADLIGHT BULB

1. Raise hood.
2. Pull bulb holder out of the hole in the backside of the grill.
3. Replace bulb in holder and push bulb holder securely back into the hole in the backside of the grill.
4. Close hood.

INTERLOCKS AND RELAYS

Loose or damaged wiring may cause your tractor to run poorly, stop running, or prevent it from starting.

- Check wiring. See electrical wiring diagram in the Repair Parts section.

TO REPLACE FUSE

Replace with 30 amp automotive-type plug-in fuse. The fuse holder is located behind the dash.

TO REMOVE HOOD AND GRILL ASSEMBLY

1. Raise hood.
2. Unsnap headlight wire connector.
3. Stand in front of tractor. Grasp hood at sides, tilt toward engine and lift off of tractor.
4. When replacing hood, be sure to re-connect the headlight wire connector.

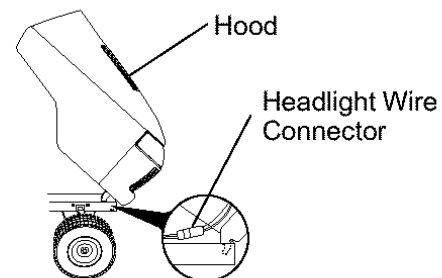

ENGINE

Maintenance, repair, or replacement of the emission control devices and systems, which are being done at the customer's expense, may be performed by any non-road engine repair establishment or individual. Warranty repairs must be performed by an authorized engine manufacturer's service outlet.

TO ADJUST THROTTLE CONTROL CABLE

The throttle control has been preset at the factory and adjustment should not be necessary. Check adjustment as described below before loosening cable. If adjustment is necessary, proceed as follows:

1. With engine not running, move throttle control lever to fast position.
2. Check that swivel is against stop. If it is not, loosen cable clamp screw and pull cable back until swivel is against stop. Tighten cable clamp screw securely.

TO ADJUST CHOKE CONTROL

The choke control has been preset at the factory and adjustment should not be necessary. Check adjustment as described below before loosening cable. If adjustment is necessary, proceed as follows:

1. With engine not running, move choke control (located on dash panel) to full choke position.
2. Loosen knob and remove cover assembly from air cleaner.
3. Choke should be closed. If it is not, loosen casing clamp screw and move choke cable until choke is completely closed. Tighten casing clamp screw securely.
4. Replace air cleaner cover assembly and tighten knob.

TO ADJUST CARBURETOR

Your carburetor is not adjustable. If your engine does not operate properly due to suspected carburetor problems, take your tractor to a Sears or other qualified service center for repair and/or adjustment. High speed stop is factory adjusted. Do not adjust - damage may result.

IMPORTANT: Never tamper with the engine governor, which is factory set for proper engine speed. Overspeeding the engine above the factory high speed setting can be dangerous. If you think the engine-governed high speed needs adjusting, contact a Sears or other qualified service center, which has proper equipment and experience to make any necessary adjustments.

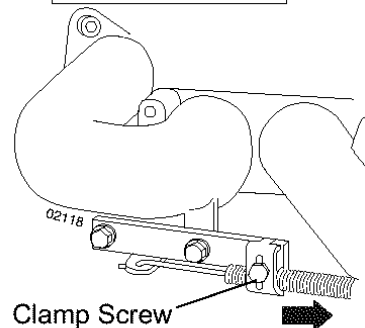
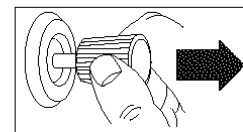
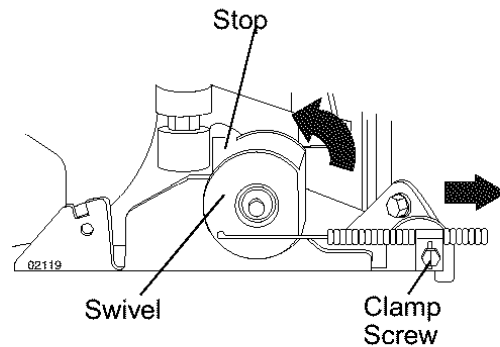

STORAGE

Immediately prepare your tractor for storage at the end of the season or if the tractor will not be used for 30 days or more.

 **WARNING:** Never store the tractor with gasoline in the tank inside a building where fumes may reach an open flame or spark. Allow the engine to cool before storing in any enclosure.

TRACTOR

Remove mower from tractor for winter storage. When mower is to be stored for a period of time, clean it thoroughly, remove all dirt, grease, leaves, etc. Store in a clean, dry area.

1. Clean entire tractor (See "CLEANING" in the Maintenance section of this manual).
2. Inspect and replace belts, if necessary (See belt replacement instructions in the Service and Adjustments section of this manual).
3. Lubricate as shown in the Maintenance section of this manual.
4. Be sure that all nuts, bolts and screws are securely fastened. Inspect moving parts for damage, breakage and wear. Replace if necessary.
5. Touch up all rusted or chipped paint surfaces; sand lightly before painting.

BATTERY

- Fully charge the battery for storage.
- After a period of time in storage, battery may require recharging.
- To help prevent corrosion and power leakage during long periods of storage, battery cables should be disconnected and battery cleaned thoroughly (see "TO CLEAN BATTERY AND TERMINALS" in the Maintenance section of this manual).
- After cleaning, leave cables disconnected and place cables where they cannot come in contact with battery terminals.
- If battery is removed from tractor for storage, do not store battery directly on concrete or damp surfaces.

ENGINE

FUEL SYSTEM

IMPORTANT: It is important to prevent gum deposits from forming in essential fuel system parts such as carburetor, fuel hose, or tank during storage. Also, experi-

ence indicates that alcohol blended fuels (called gasohol or using ethanol or methanol) can attract moisture which leads to separation and formation of acids during storage. Acidic gas can damage the fuel system of an engine while in storage.

- Empty the fuel tank by starting the engine and letting it run until the fuel lines and carburetor are empty.
- Never use engine or carburetor cleaner products in the fuel tank or permanent damage may occur.
- Use fresh fuel next season.

NOTE: Fuel stabilizer is an acceptable alternative in minimizing the formation of fuel gum deposits during storage. Add stabilizer to gasoline in fuel tank or storage container. Always follow the mix ratio found on stabilizer container. Run engine at least 10 minutes after adding stabilizer to allow the stabilizer to reach the carburetor. Do not empty the gas tank and carburetor if using fuel stabilizer.

ENGINE OIL

Drain oil (with engine warm) and replace with clean engine oil. (See "ENGINE" in the Maintenance section of this manual).

CYLINDER(S)

1. Remove spark plug(s).
2. Pour one ounce of oil through spark plug hole(s) into cylinder(s).
3. Turn ignition key to "START" position for a few seconds to distribute oil.
4. Replace with new spark plug(s).

OTHER

- Do not store gasoline from one season to another.
- Replace your gasoline can if your can starts to rust. Rust and/or dirt in your gasoline will cause problems.
- If possible, store your tractor indoors and cover it to give protection from dust and dirt.
- Cover your tractor with a suitable protective cover that does not retain moisture. Do not use plastic. Plastic cannot breathe which allows condensation to form and will cause your tractor to rust.

IMPORTANT: Never cover tractor while engine and exhaust areas are still warm.

TROUBLESHOOTING CHART:

See appropriate section in manual unless directed to Sears service center

PROBLEM	CAUSE	CORRECTION
Will not start	<ol style="list-style-type: none">1. Out of fuel.2. Engine not "CHOKED" properly.3. Engine flooded. 4. Bad spark plug.5. Dirty air filter.6. Dirty fuel filter.7. Water in fuel. 8. Loose or damaged wiring.9. Carburetor out of adjustment. 10. Engine valves out of adjustment.11. Extreme Cold Conditions	<ol style="list-style-type: none">1. Fill fuel tank.2. See "TO START ENGINE" in Operation section.3. Wait several minutes before attempting to start.4. Replace spark plug.5. Clean/replace air filter.6. Replace fuel filter.7. Empty fuel tank and carburetor, refill tank with fresh gasoline and replace fuel filter.8. Check all wiring.9. See "To Adjust Carburetor" in Service and Adjustments section.10. Contact a Sears or other qualified service center.11. See "To start engine" in operation section.
Hard to start	<ol style="list-style-type: none">1. Dirty air filter.2. Bad spark plug.3. Weak or dead battery.4. Dirty fuel filter.5. Stale or dirty fuel. 6. Loose or damaged wiring.7. Carburetor out of adjustment. 8. Engine valves out of adjustment.	<ol style="list-style-type: none">1. Clean/replace air filter.2. Replace spark plug.3. Recharge or replace battery.4. Replace fuel filter.5. Empty fuel tank and refill tank with fresh, clean gasoline.6. Check all wiring.7. See "To Adjust Carburetor" in Service and Adjustments section.8. Contact a Sears or other qualified service center.
Engine will not turn over	<ol style="list-style-type: none">1. Brake pedal not depressed2. Attachment clutch is engaged.3. Weak or dead battery.4. Blown fuse.5. Corroded battery terminals.6. Loose or damaged wiring.7. Faulty ignition switch. 8. Faulty solenoid or starter. 9. Faulty operator presence switch(es).	<ol style="list-style-type: none">1. Depress brake pedal.2. Disengage attachment clutch.3. Recharge or replace battery.4. Replace fuse.5. Clean battery terminals.6. Check all wiring.7. Check/replace ignition switch.8. Check/replace solenoid or starter.9. Contact a Sears or other qualified service center.
Engine clicks but will not start	<ol style="list-style-type: none">1. Weak or dead battery.2. Corroded battery terminals.3. Loose or damaged wiring.4. Faulty solenoid or starter.	<ol style="list-style-type: none">1. Recharge or replace battery.2. Clean battery terminals.3. Check all wiring.4. Check/replace solenoid or starter.

TROUBLESHOOTING CHART:

See appropriate section in manual unless directed to Sears service center

PROBLEM	CAUSE	CORRECTION
Loss of power	<ol style="list-style-type: none">1. Cutting too much grass/too fast.2. Throttle in "CHOKE" position.3. Build-up of grass, leaves and trash under mower.4. Dirty air filter.5. Low oil level/dirty oil.6. Faulty spark plug.7. Dirty fuel filter.8. Stale or dirty fuel.9. Water in fuel.10. Spark plug wire loose.11. Dirty engine air screen/fins.12. Dirty/clogged muffler.13. Loose or damaged wiring.14. Carburetor out of adjustment.15. Engine valves out of adjustment.	<ol style="list-style-type: none">1. Raise cutting height/reduce speed.2. Adjust throttle control.3. Clean underside of mower housing.4. Clean/replace air filter.5. Check oil level/change oil.6. Clean and regap or change spark plug.7. Replace fuel filter.8. Empty fuel tank and refill tank with fresh, clean gasoline.9. Empty fuel tank and carburetor, refill tank with fresh gasoline and replace fuel filter.10. Connect and tighten spark plug wire.11. Clean engine air screen/fins.12. Clean/replace muffler.13. Check all wiring.14. See "To Adjust Carburetor" in Service and Adjustments section.15. Contact a Sears or other qualified service center.
Excessive vibration	<ol style="list-style-type: none">1. Worn, bent or loose blade.2. Bent blade mandrel.3. Loose/damaged part(s).	<ol style="list-style-type: none">1. Replace blade. Tighten blade bolt.2. Contact a Sears or other qualified service center.3. Tighten loose part(s). Replace damaged parts.
Engine dies when tractor is shifted into reverse	<ol style="list-style-type: none">1. Reverse operation system (ROS) is not "ON" while mower or other attachment is engaged.	<ol style="list-style-type: none">1. Turn ignition key to ROS "ON" position. See Operation section.
Engine continues to run when operator leaves seat with attachment clutch engaged	<ol style="list-style-type: none">1. Faulty operator-safety presence control system.	<ol style="list-style-type: none">1. Check wiring, switches and connections. If not corrected, contact a Sears or other qualified service center.
Poor cut - uneven	<ol style="list-style-type: none">1. Worn, bent or loose blade.2. Mower deck not level.3. Buildup of grass, leaves, and trash under mower.4. Bent blade mandrel.5. Clogged mower deck vent from build-up of grass, leaves, and trash around mandrels.	<ol style="list-style-type: none">1. Replace blade. Tighten blade bolt.2. Level mower deck.3. Clean underside of mower housing.4. Contact a Sears or other qualified service center.5. Clean around mandrels to open vent holes.

TROUBLESHOOTING CHART:

See appropriate section in manual unless directed to Sears service center

PROBLEM	CAUSE	CORRECTION
Mower blades will not rotate	<ol style="list-style-type: none"> 1. Obstruction in clutch mechanism. 2. Worn/damaged mower drive belt. 3. Frozen idler pulley. 4. Frozen blade mandrel. 	<ol style="list-style-type: none"> 1. Remove obstruction. 2. Replace mower drive belt. 3. Replace idler pulley. 4. Contact a Sears or other qualified service center.
Poor grass discharge	<ol style="list-style-type: none"> 1. Engine speed too slow. 2. Travel speed too fast. 3. Wet grass. 4. Mower deck not level. 5. Low/uneven tire air pressure. 6. Worn, bent or loose blade. 7. Buildup of grass, leaves and trash under mower. 8. Mower drive belt worn. 9. Blades improperly installed. 10. Improper blades used. 11. Clogged mower deck vent holes from buildup of grass, leaves, and trash around mandrels. 	<ol style="list-style-type: none"> 1. Place throttle control in "FAST" position. 2. Shift to slower speed. 3. Allow grass to dry before mowing. 4. Level mower deck. 5. Check tires for proper air pressure. 6. Replace/sharpen blade. Tighten blade bolt. 7. Clean underside of mower housing. 8. Replace mower drive belt. 9. Reinstall blades sharp edge down. 10. Replace with blades listed in this manual. 11. Clean around mandrels to open vent holes.
Headlight(s) not working (if so equipped)	<ol style="list-style-type: none"> 1. Light switch is "OFF". 2. Bulb(s) or lamp(s) burned out. 3. Faulty light switch. 4. Loose or damaged wiring. 5. Blown fuse. 	<ol style="list-style-type: none"> 1. Turn light switch "ON". 2. Replace bulb(s) or lamp(s). 3. Check/replace light switch. 4. Check wiring and connections. 5. Replace fuse.
Battery will not charge	<ol style="list-style-type: none"> 1. Bad battery cell(s). 2. Poor cable connections. 3. Faulty regulator (if so equipped). 4. Faulty alternator. 	<ol style="list-style-type: none"> 1. Replace battery. 2. Check/clean all connections. 3. Replace regulator. 4. Replace alternator.
Loss of drive	<ol style="list-style-type: none"> 1. Freewheel control in "disengaged" position. 2. Motion drive belt worn, damaged, or broken. 3. Air trapped in transmission during shipment or servicing. 	<ol style="list-style-type: none"> 1. Place freewheel control in "engaged" position. 2. Replace motion drive belt. 3. Purge transmission.
Engine "backfires" when turning engine "OFF"	<ol style="list-style-type: none"> 1. Engine throttle control not set between half and full speed (fast) position before stopping engine. 	<ol style="list-style-type: none"> 1. Move throttle control between half and full speed (fast) position before stopping engine.

TRACTOR -- MODEL NUMBER 917.276320

SCHEMATIC

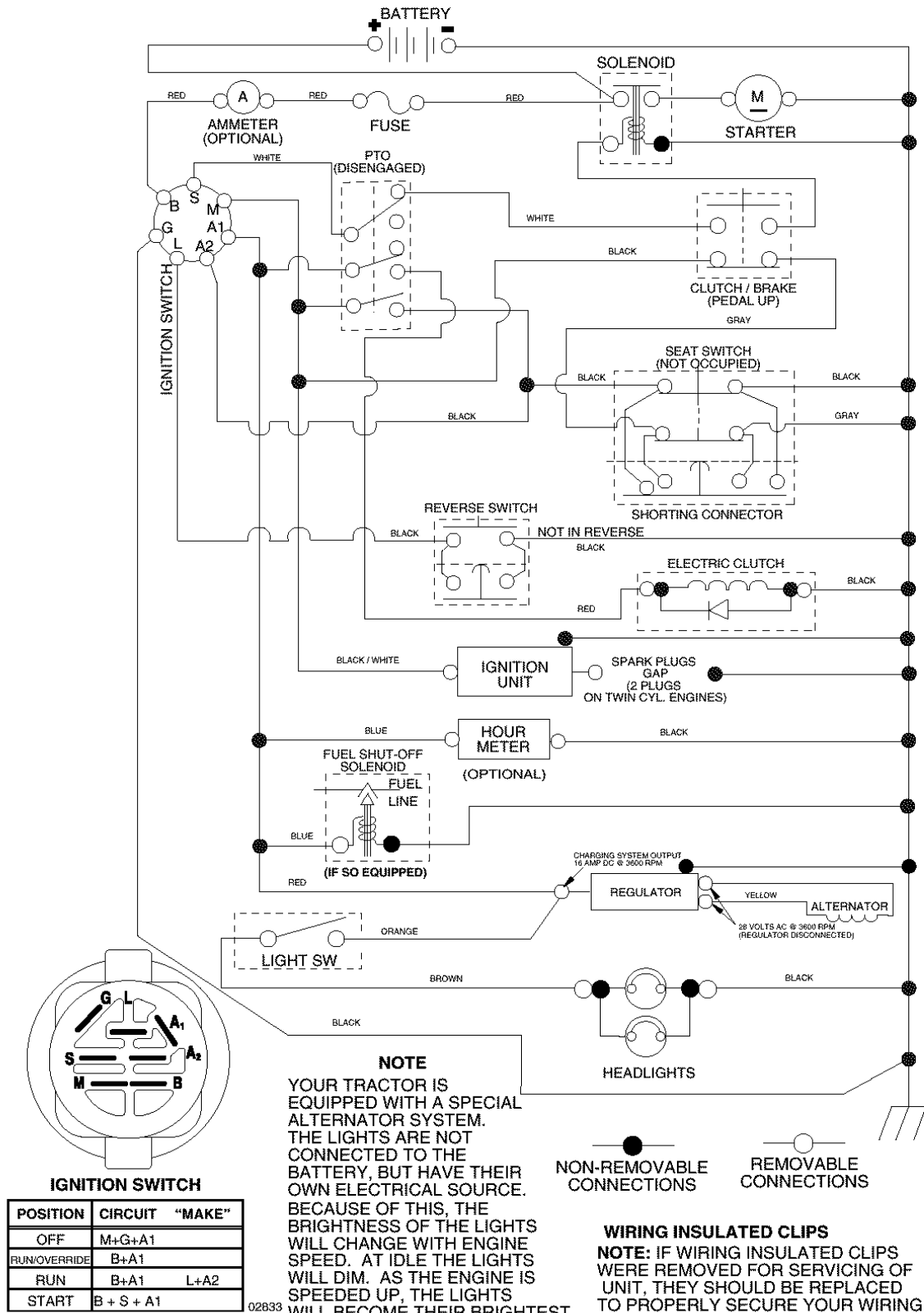

REPAIR PARTS

TRACTOR -- MODEL NUMBER 917.276320

ELECTRICAL

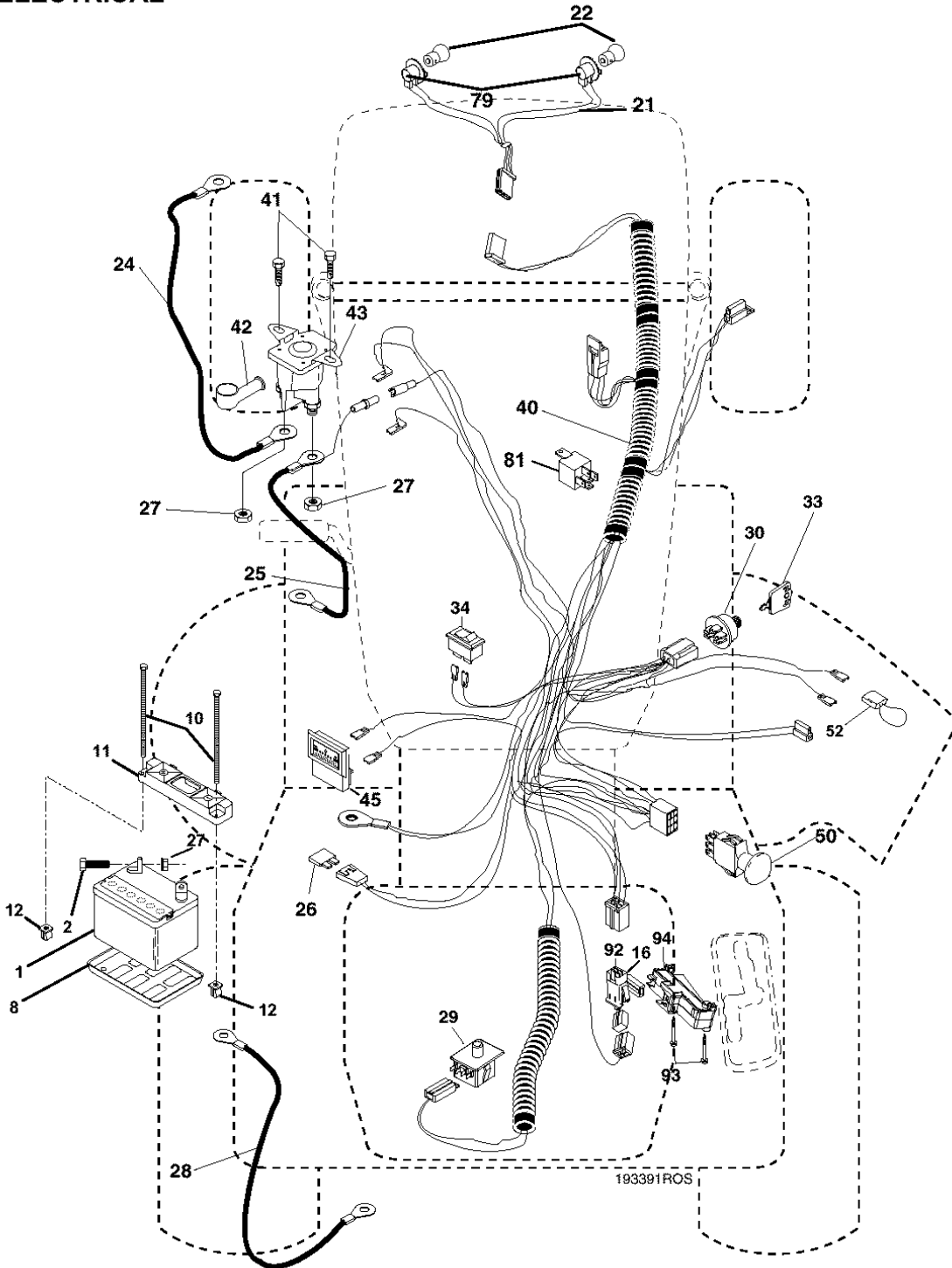

ELECTRICAL**TRACTOR -- MODEL NUMBER 917.276320**

KEY NO.	PART NO.	DESCRIPTION
1	144927	Battery
2	74760412	Bolt Hex Head 1/4-20 x 3/4
8	7603J	Tray, Battery
10	145211	Bolt 1/4-20 x 7.5 Zinc
11	150109	Hold down Battery Dash Mount
12	145769	Nut Push Nylon 1/4"
16	176138	Switch Interlock Push-in
21	175688	Harness Socket Light W/4152J
22	4152J	Bulb Light
24	185464	Cable Starter
25	146149	Cable, Battery
26	108824X	Fuse
27	73510400	Nut Keps Hex 1/4-20 unc
28	170697	Cable, Ground
29	192749	Switch, Seat
30	193350	Switch, Ign
33	140403	Key, Ignition
34	110712X	Switch Light/Reset
40	193391	Harness Ign.
41	17720408	Screw Thd Cut 1/4-20 x 1/2
42	131563	Cover, Terminal
43	178861	Solenoid
45	122822X	Ammeter
50	174652	Switch, PTO
52	141940	Hourmeter Adaptor
79	175242	Bulbholder Asm Incandescent SV
92	193465	Harness Pigtail Reverse Switch
93	192540	Screw Plastite 10-14 x 2.0
94	191834	Module Reverse ROS

NOTE: All component dimensions given in U. S.
inches 1 inch = 25.4 mm

TRACTOR -- MODEL NUMBER 917.276320

CHASSIS AND ENCLOSURES

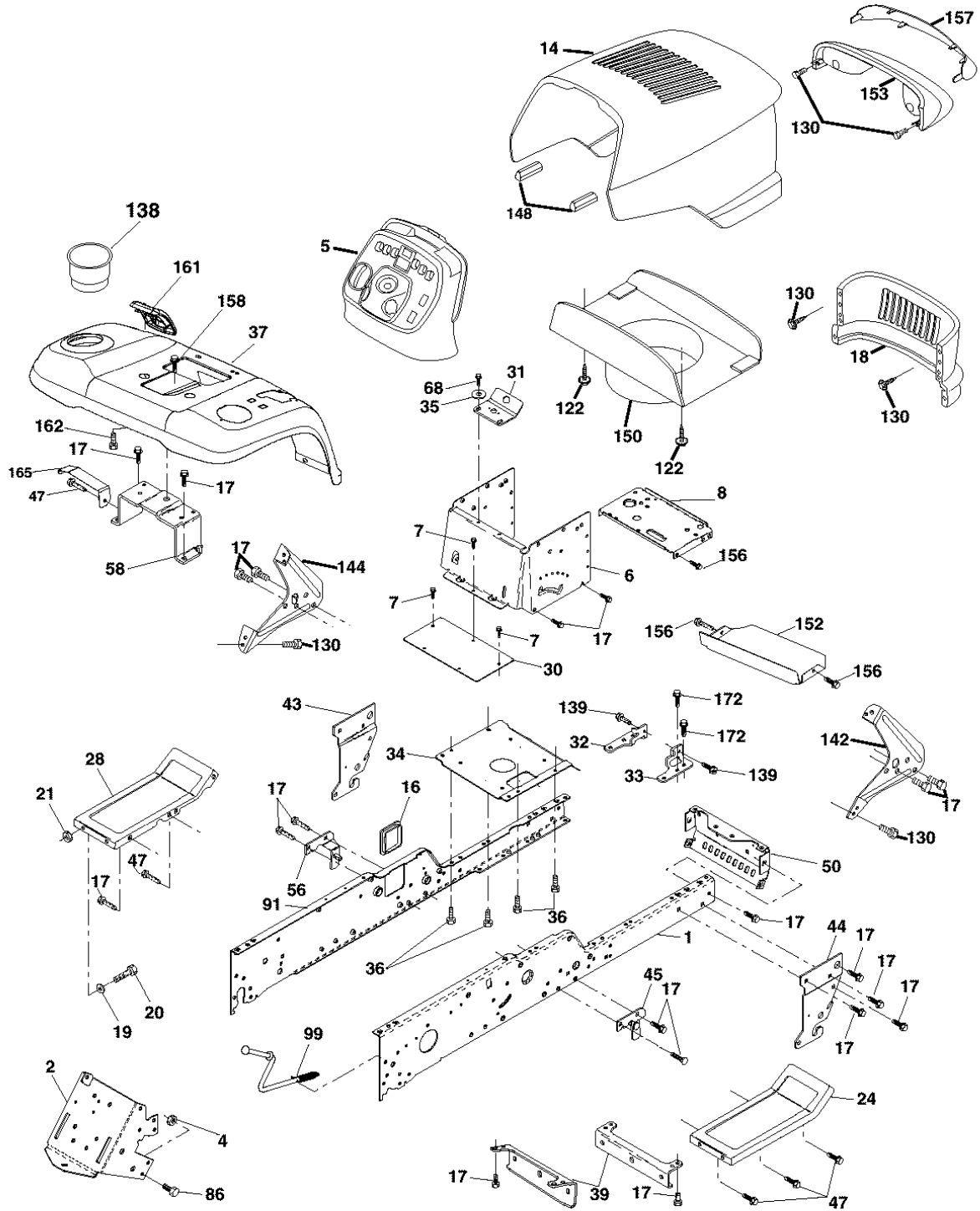

chassis-stealth_43-vgt

TRACTOR -- MODEL NUMBER 917.276320
CHASSIS AND ENCLOSURES

KEY PART NO. NO.	DESCRIPTION	KEY PART NO. NO.	DESCRIPTION
1	180375	47	17490608
2	175282	50	175476
4	73680700	56	176016
5	193636X428	58	183569
6	157882	68	17490508
7	17720408	86	74780716
8	184668	91	180374
14	175260X615	99	177143
16	121794X	122	192572
17	17000612	130	191611
18	174515X615	138	191121X428
19	19131312	139	171873
20	STD523710	142	161897
21	STD541437	144	161900
24	179717X615	148	164655
28	179716X615	150	175352
30	145052	152	177956
31	161419	153	179761
32	161327	156	17000512
33	161326	157	161840
34	177018	158	17670608
35	19111116	161	179612X428
36	17060512	162	142432
37	192397X615	165	183554
39	175278	172	17120614
43	136939		
44	136940		
45	176018		

NOTE: All component dimensions given in U. S. inches 1 inch = 25.4 mm

TRACTOR -- MODEL NUMBER 917.276320

GROUND DRIVE

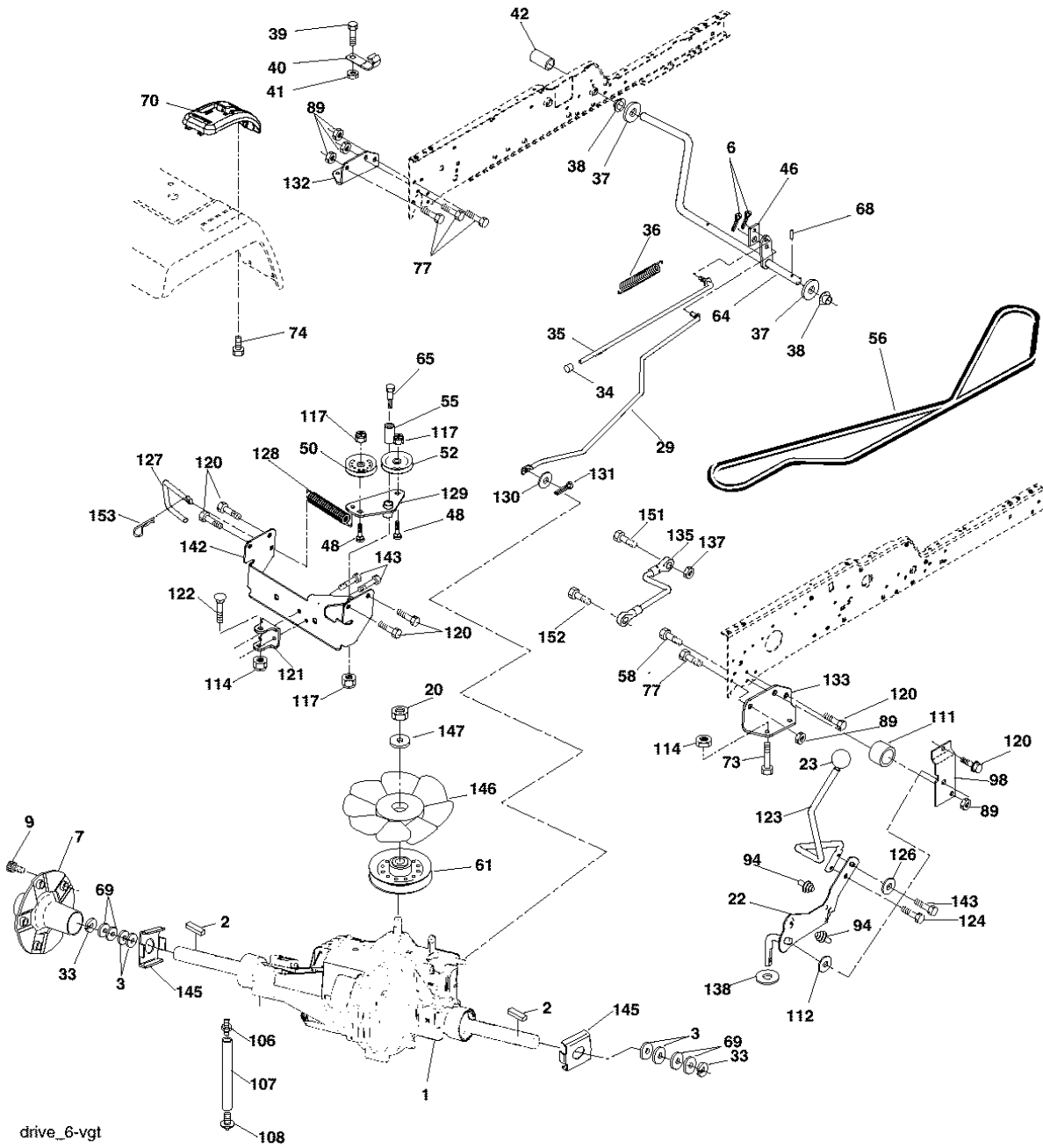

TRACTOR -- MODEL NUMBER 917.276320

GROUND DRIVE

KEY PART NO. NO.	DESCRIPTION	KEY PART NO. NO.	DESCRIPTION
1	----- Transaxle Hydro Gear 331-3000 (See Breakdown)	94	133835 Fastener Christmas Tree
2	7070E Key 1/4 x 2.5	98	141004 Bracket Shift
3	7563R Washer Thrust	106	142918 O-Ring Asm Hydro Gear
6	STD561210 Pin, Cotter	107	154739 Line Fuel Hydro 15" VGT
7	140507 Wheel, Hub Assembly	108	142917 Cap Asm Vent Hydro Gear 70109
9	140080 Bolt, Hub	111	156240 Spacer Shift Lever VGTH
20	73940800 Nut	112	178558 Washer Nylon High Temp
22	180235 Lever Asm Shift Lower	114	73800500 Nut Lock Hx W/Ins 5/16-18 unc
23	130564 Knob	117	73900600 Nut, Lock Flg. 3/8-16
29	176600 Brake, Rod	120	17000612 Screw 3/8-16 x .75
33	12000053 Ring E	121	175611 Bracket Strap Torque
34	71673 Cap, Parking Brake	122	72010520 Bolt RDHD SQ 5/16-18 unc x 2-1/2
35	137648 Rod, Parking Brake	123	192438 Rod Shift
36	149412 Spring, Drive Ground	124	165492 Bolt Shoulder 5/16-18 x .561
37	121749X Washer 25/32 x 1-1/4 x 16 Ga.	126	166002 Washer SRRTD 5/16 ID x 1.0 x .125
38	150035 Nyliner	127	177362 Link Control Clutch
39	74321016 Screw, Fin. #10-24 x 1	128	176624 Spring Drive GRND
40	178575 Actuator, Interlock Switch	129	179473 Bracket Asm Idler Tensioning
41	73931000 Nut Centerlock 10-24 unc	130	19131016 Washer 13/32 x 5/8 x 16 Ga.
42	8883R Cover, Pedal	131	76020312 Pin Cotter 3/32 x 3/4
46	145170 Retainer, Spring	132	175467 Bracket Mtg Hydro 3500 LH VGT
48	72110614 Bolt, 3/8-16 x 1-3/4 Gr. 5	133	175468 Bracket Mtg Hydro 3500 RH VGT
50	131494 Pulley, Idler, Flat	135	177364 Link Asm Control Hydro 3500
52	127783 Pulley, Idler, Grooved	137	1685H Nut Lock 5/16-18 NC Thd
55	105706X Bearing, Idler	138	1370H Washer Thrust 5/8 x 1.10 x 1/32
56	161597 V-Belt	142	175469 Strap Torque HG-3500
58	74760724 Bolt Fin Hex 7/16-14 x 1-1/2	143	17000512 Screw Thdrol 5/16-18 x 3/4
61	143995 Pulley, Transaxle	145	163168 Washer Axle Flange HG-3000
64	176601 Shaft, Clutch/Brake Pedal	146	140462 Fan 7" Hydro
65	179613 Bolt, Shoulder	147	141322 Washer
68	STD571812 Pin, Roll	151	74760514 Bolt Fin Hex 5/16-18 x 7/8
69	123800X Washer	152	178705 Bolt hex 5/16-18 x 1
70	192390X428 Console Shift	153	4497H Retainer Spring
73	74490548 Bolt Hex Flghd 5/16-18 x 3 Gr. 5		
74	142432 Screw Hex Wsh. Hi-Lo 1/4-1/2		
77	74780716 Bolt Hex 7/16-14 x 1-1/4 Gr. 5		
89	73680700 Nut Crownlock 7/16-14 unc		

NOTE: All component dimensions given in U. S. inches 1 inch = 25.4 mm

TRACTOR -- MODEL NUMBER 917.276320

STEERING

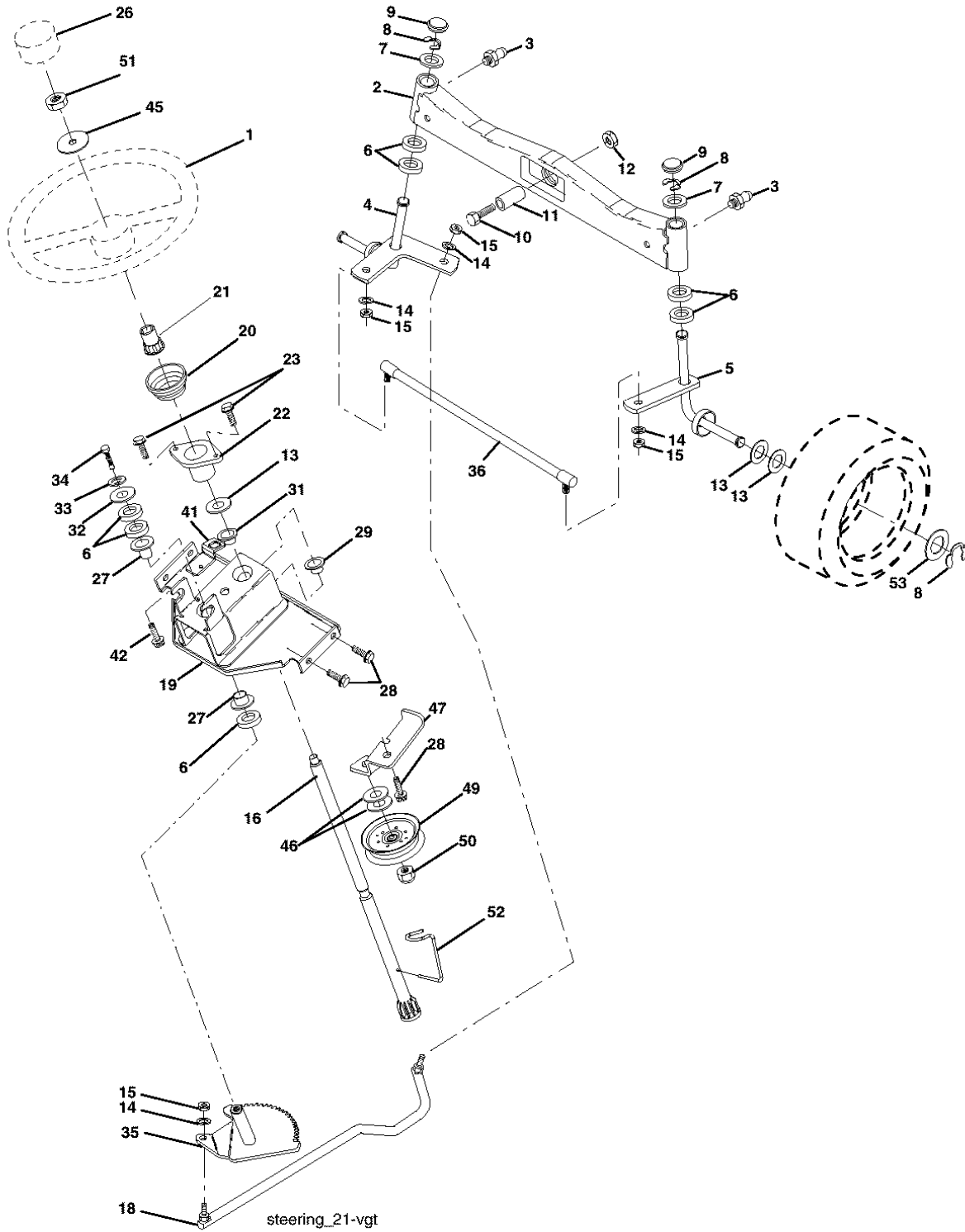

TRACTOR -- MODEL NUMBER 917.276320

STEERING

KEY NO.	PART NO.	DESCRIPTION
1	186093X428	Wheel, Steering
2	178557	Axle Asm., Front
3	183226	Fitting, Grease
4	161849	Spindle Asm, LH
5	161848	Spindle Asm., RH
6	6266H	Bearing, Race Thrust Harden
7	121748X	Washer 25/32 x 1-5/8 x 16 Ga.
8	12000029	Ring, Klip #T5304-75
9	184946X505	Cap, Spindle
10	74781044	Bolt, Fin Hex 5/8-11 x 2-3/4
11	136518	Spacer Bearing Axle Front
12	73901000	Nut, Lock Flange 5/8-11 unc
13	121749X	Washer 25/32 x 1-1/4 x 16 Ga.
14	STD551137	Washer, Lock Hvy Hlcl Spr 3/8
15	STD541537	Nut, Lock Center 3/8-24 unf
16	186814	Shaft Asm., Steering
18	175572	Draglink Vgt
19	156011	Support Asm., Steering Vgt
20	163887X428	Boot, Steering
21	186737	Adapter, Wheel Steering
22	155105	Bushing, Strg. Blk
23	152927	Screw
26	186095X428	Cap, Wheel Steering
27	3366R	Bearing, Col. Strg.
28	17000612	Screw, 3/8-16 x 3/4
29	104239X	Bearing, Flange
31	138136	Bushing, Nyliner Snap
32	19111610	Washer 11/32 x 1 x 10 Ga.
33	STD551131	Washer, Lock Hvy Hlcl Spr 5/16
34	74780512	Bolt Fin Hex 5/16-18 unc x 3/4
35	187039	Gear, Sector Steering
36	186799	Tie Rod
41	155246	Bracket Switch Interlock VGT 97
42	17490508	Screw Thdrol 5/16-18 x 1/2 Tyt
45	19183812	Washer 9/16 ID x 2-3/8 OD 12 Ga.
46	19131610	Washer Flat 13/32 x 1 x 10 Ga.
47	179471	Bracket Asm Idler Stationary
49	175820	Pulley Idler Flat
50	73900600	Nut Lock Flg 3/8-16 unc
51	73940800	Nut Hex Jam Toplock 1/2-20 unf
52	175553	Clip Steering .750
53	188967	Washer Hardened

NOTE: All component dimensions given in U. S. inches 1 inch = 25.4 mm

TRACTOR -- MODEL NUMBER 917.276320

ENGINE

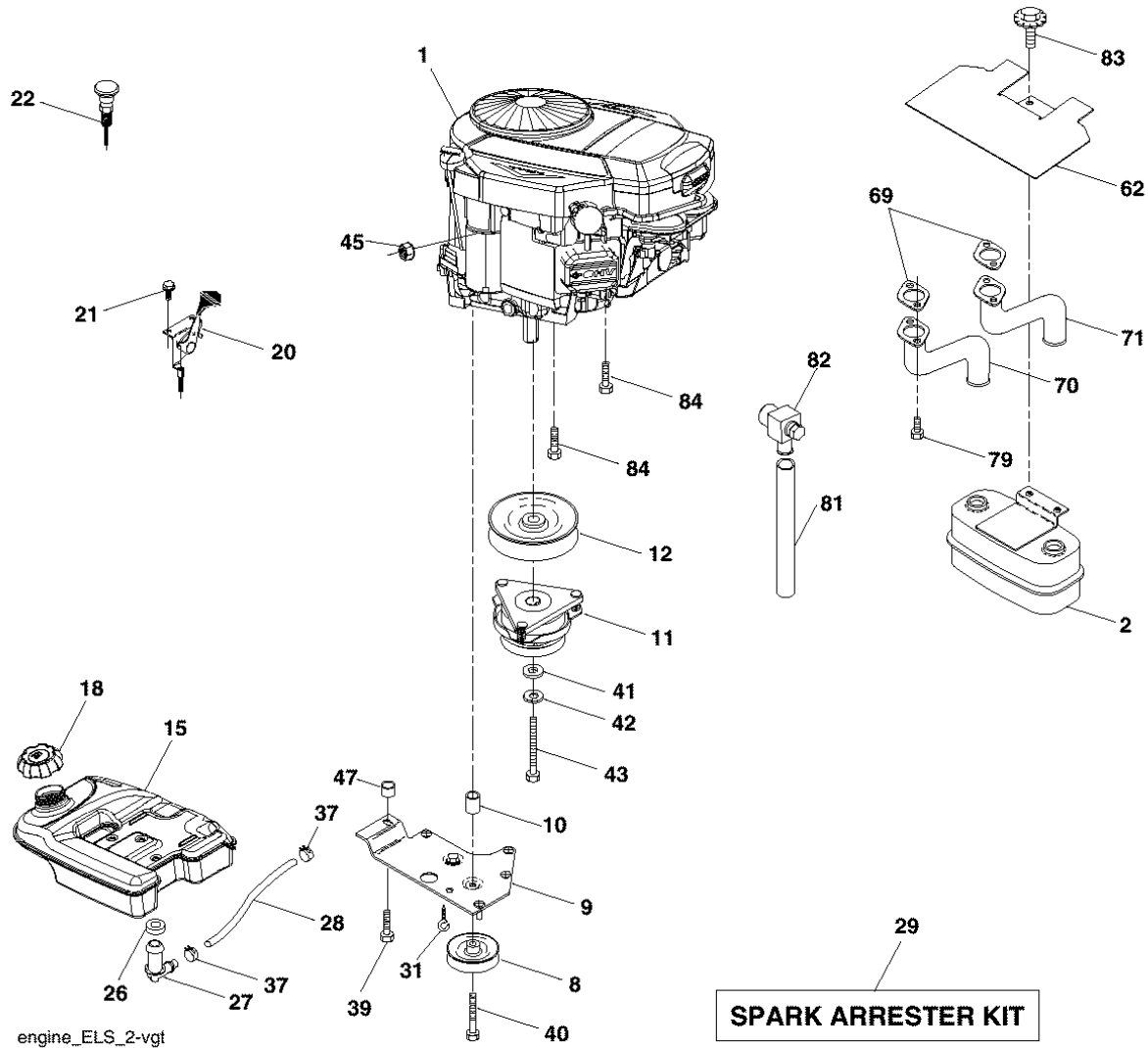

engine_ELS_2-vgt

KEY PART NO. NO.

KEY PART NO.	NO.	DESCRIPTION
1	-----	Engine (See Breakdown) Briggs Model No. 446677-0470-E1
2	149723	Muffler
8	121361X	Pulley V-Idler
9	177748	Keeper Asm. Belt Engine
10	175288	Bushing
11	179335	Clutch Electric
12	143996	Pulley Engine VGT Elect Clutch
15	179115	Tank Fuel Rear 5.0 Yt/Gt 96
18	179124X428	Cap Asm Fuel W/Gauge
20	175437X428	Control Throttle
21	191611	Screw 10 x 3/4 Single Lead Hex
22	187767X428	Control Choke
26	3645J	Bushing
27	139277	Stem Tank Fuel
28	7834R	Fuel Line
29	137180	Spark Arrester Kit
31	145006	Clip Push-In Hinged
37	123487X	Clamp Hose

KEY PART NO. NO.

KEY PART NO.	NO.	DESCRIPTION
39	17490636	Screw TT 3/8-16 x 2-1/4 unc
40	17490664	Screw TT 3/8-16 x 4 unc
41	126197X	Washer 1-1/2 OD x15/32 ID x .250
42	STD551143	Washer Lock 7/16
43	179953	Bolt Hex 7/16 - 20 x 3.75 Gr. 5
45	73510400	Nut Keps Hex 1/4-20 unc
47	175287	Spacer Engine
62	146629	Shield Heat Muffler
69	165391	Gasket
70	176069	Tube Exhaust LH
71	176070	Tube Exhaust RH
79	183906	Screw Socket Head 5/16-18 x 1
81	188800	Tube Drain Oil
82	188799	Drain Oil Valve
83	171877	Bolt 5/16-18 unc x 3/4
84	17060624	Screw 3/8-16 x 1-1/2

NOTE: All component dimensions given in U. S. inches 1 inch = 25.4 mm

TRACTOR -- MODEL NUMBER 917.276320

SEAT ASSEMBLY

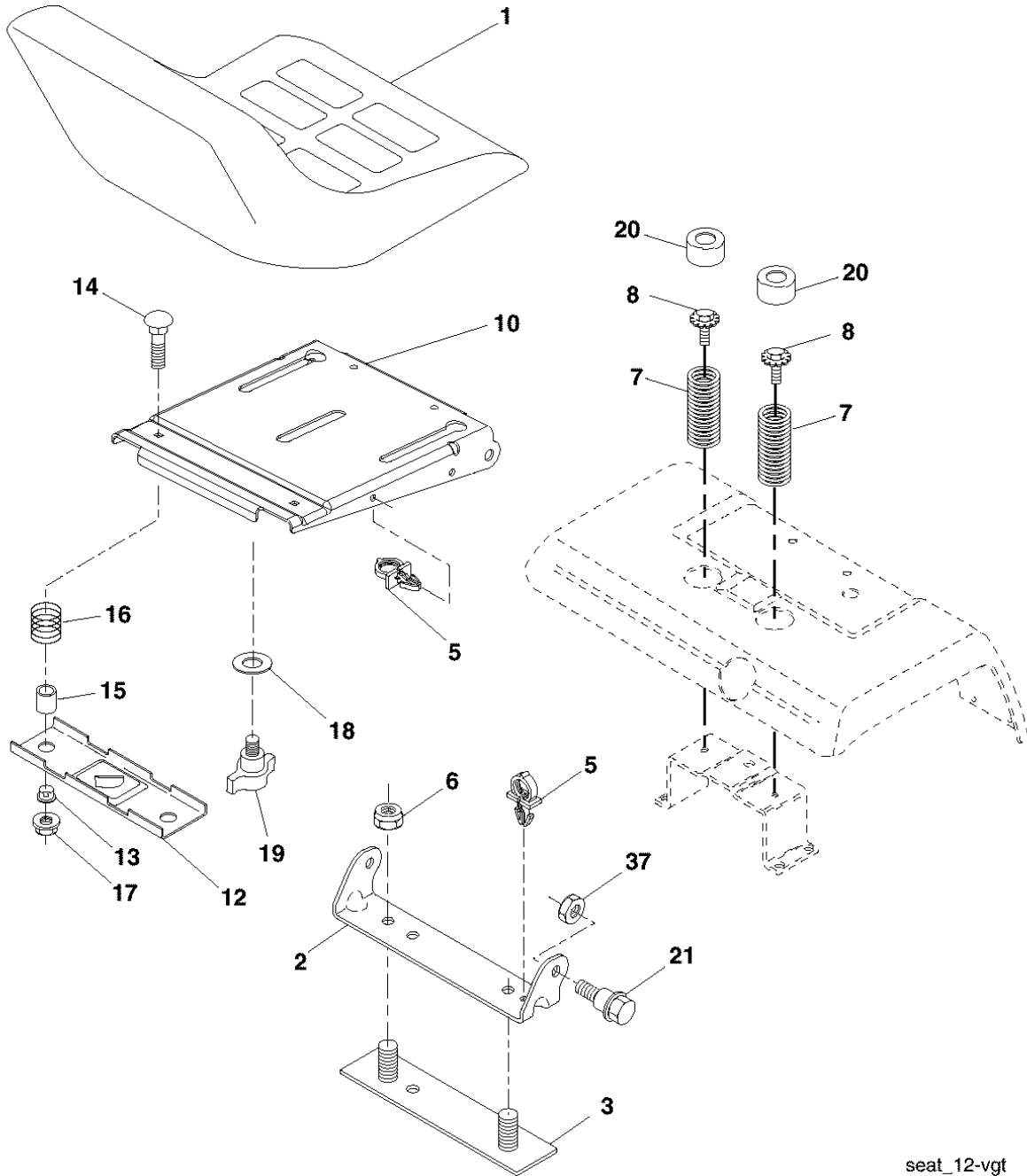

**KEY PART
NO. NO.**

KEY PART NO.	NO.	DESCRIPTION
1	180598	Seat
2	180166	Bracket, Pivot Seat
3	140675	Strap, Fender Assembly
5	145006	Clip, Push In, Hinged
6	STD541437	Nut 3/8-16 unc
7	124181X	Spring, Seat Cprsn
8	171877	Bolt 5/16-18Unc x 3/4 w/Sems
10	180186	Pan, Seat
12	174648	Bracket, Mounting Switch
13	121248X	Bushing, Snap
14	72050412	Bolt, Carriage 1/4-20 x 1-1/2

**KEY PART
NO. NO.**

KEY PART NO.	NO.	DESCRIPTION
15	121249X	Spacer, Split
16	123740X	Spring, Cprsn
17	123976X	Nut, Lock 1/4 Lge Flg Gr. 5
18	19171912	Washer 17/32 x 1-3/16 x 12 Ga.
19	166369	Knob, Seat
20	124238X	Cap, Spring Seat
21	171852	Bolt, Shoulder 5/16-18
37	73800500	Nut, Lock Hx w/Ins. 5/16-18

NOTE: All component dimensions given in U. S. inches 1 inch = 25.4 mm

TRACTOR -- MODEL NUMBER 917.276320

DECALS

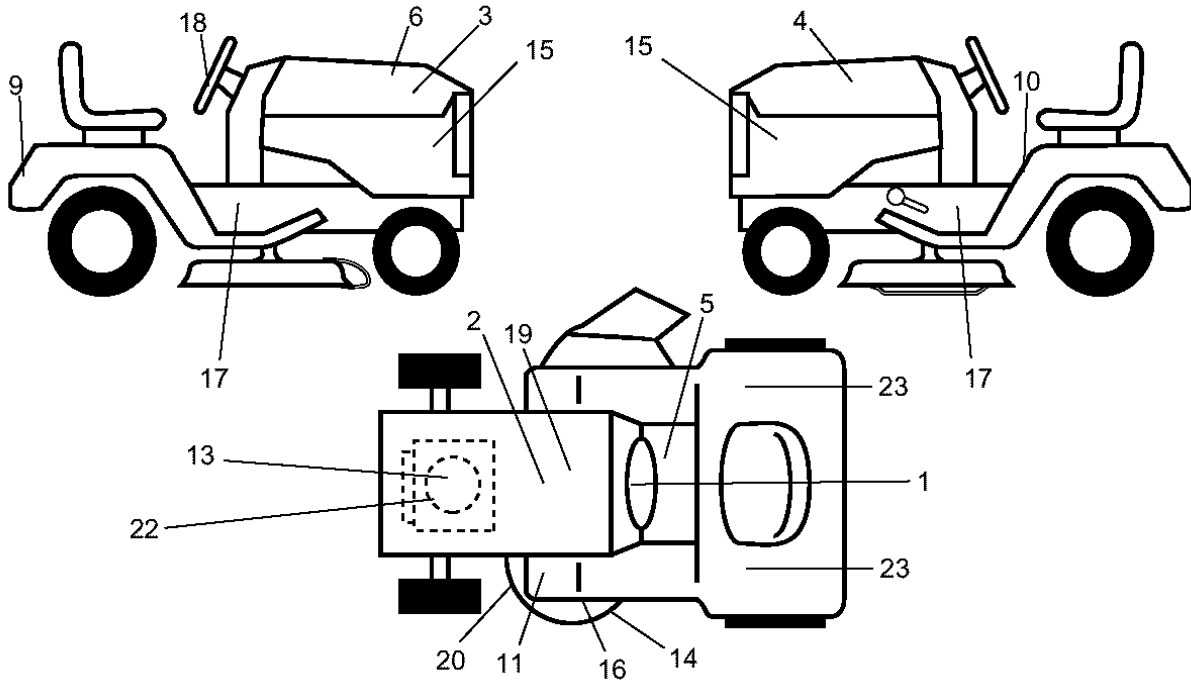

KEY PART NO. NO.

KEY PART NO.	NO.	DESCRIPTION
1	193599	Decal Dash
2	149516	Decal Battery DNGR/PSN
3	186242	Decal Hood RH
4	186243	Decal Hood LH
5	140837	Decal Brake Parking Saddle
6	133644	Decal Maintenance
9	186572	Decal Fender
10	156439	Decal Fender Danger
11	181252	Decal FTREST
13	195885	Decal Replacement
14	175291	Decal V-Belt Schem
15	186725	Decal Hood Side Prtl

KEY PART NO. NO.

KEY PART NO.	NO.	DESCRIPTION
16	178482	Decal Deck HVYDTY
17	195838	Decal Chassis
18	164065	Decal Insert Strg
19	138047	Decal Battery
20	178455	Decal Deck Caution
22	191066	Decal Engine
23	106202X	Reflector, Taillight
--	179768X428	Pad Footrest LH
--	166960	Decal Drawbar CNTRL
--	179769X428	Pad Footrest RH
--	195627	Owner's Manual, English
--	195628	Owner's Manual, Spanish

WHEELS AND TIRES

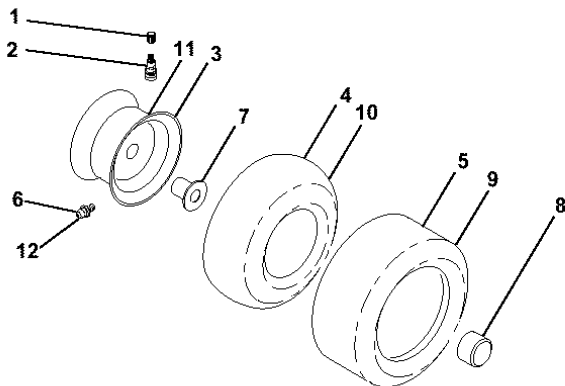

KEY PART NO. NO.

KEY PART NO.	NO.	DESCRIPTION
1	59192	Cap Valve Tire
2	65139	Stem Valve
3	106228X624	Rim Asm Front
4	8134H	Tube, Front (Service Item Only)
5	105588X	Tire, Front
6	278H	Fitting Grease (Front Wheel Only)
7	9040H	Bearing Flange(Front Wheel Only)
8	104757X428	Cap Axle (Front Wheel Only)
9	106230X	Tire Rear
10	7154J	Tube Rear (Service Item Only)
11	106277X624	Rim Asm Rear
12	6856M	Fitting Grease
--	144334	Sealant, Tire (10 oz. Tube)

NOTE: All component dimensions given in U. S. inches 1 inch = 25.4 mm

TRACTOR -- MODEL NUMBER 917.276320

LIFT ASSEMBLY

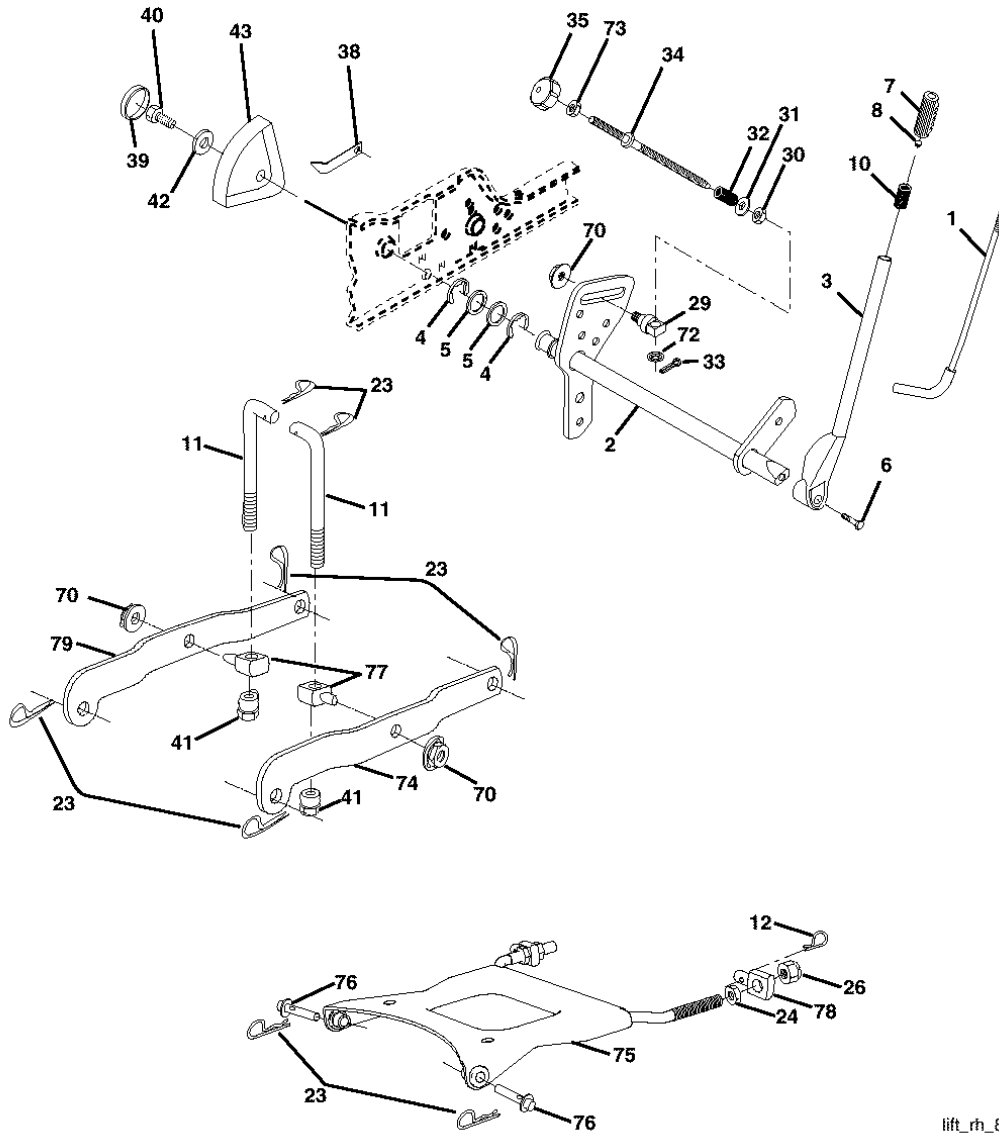

lift_rh_8

KEY PART NO. NO.

DESCRIPTION

1	121006X	Rod Asm., Lever
2	180045	Shaft Asm., Lift Vgt
3	159189	Lever Asm., Lift Rh
4	1200022	E-Ring Truarc #5133-87
5	19292016	Washer 29/32 x 1-1/4 x 16 Ga.
6	71110624	Bolt, Fin Hex 3/8-16 x 1-1/2
7	175830	Grip, Handle Fluted
8	175831X505	Plunger, Button
10	183894	Spring
11	175375	Link Lift
12	163552	Retainer Spring
23	STD624008	Retainer, Spring
24	73350800	Nut, Jam Hex 1/2-13 Unc
26	73800800	Nut Crownlock 1/2-13 Unc
29	150233	Trunnion, Infn Height
30	110807X	Nut, Special
31	STD551037	Washer 13/32 x 5/8 x 16 Ga.
32	137150	Spring, Compression Infn Hgt
33	STD560907	Pin, Cotter 3/32 x 1/2
34	137167	Rod, Adj Lift

KEY PART NO. NO.

DESCRIPTION

35	138057	Knob, Infn 3/8-16 Unc
38	155097	Pointer, Height Indicator
39	123935X	Plug, Hole
40	17060516	Screw Hex Wsh 5/16-18 x 1
41	175994	Nut, Lift Link 7/16-20
42	19112410	Washer 11/32 x 1-1/2 x 10 Ga.
43	123934X	Scale, Indicator Height
70	145212	Nut Hex Flange Lock
72	110452X	Nut Push Phos & Oil
73	73350600	Nut Hex Jam 3/8-16 UNC
74	175802	Arm Susp. Rear RH
75	175805	Plate Asm. Susp. Front
76	175560	Pin, Flange
77	176205	Trunnion Susp. Arm
78	175689	Trunnion Susp. Front
79	175378	Arm, susp. R LH

NOTE: All component dimensions given in U. S. inches 1 inch = 25.4 mm

TRACTOR -- MODEL NUMBER 917.276320

MOWER DECK

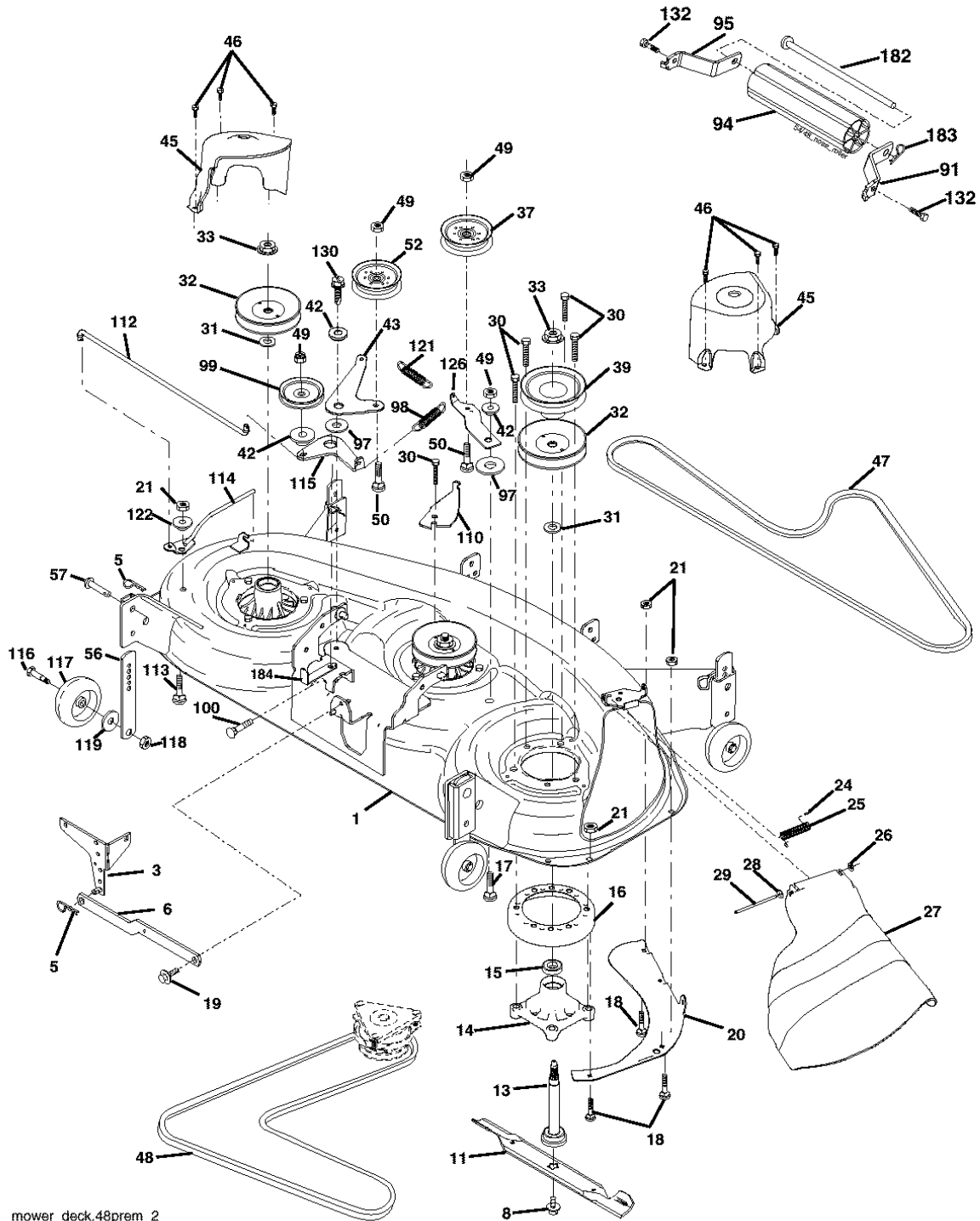

mower_deck.48prem_2

TRACTOR -- MODEL NUMBER 917.276320

MOWER DECK

KEY PART NO. NO.	DESCRIPTION	KEY PART NO. NO.	DESCRIPTION		
1	180358	52	175820	Deck Weldment Mower 48	Pulley Idler Flat
3	178915	56	155986	Bracket Asm., Sway Bar	Bar Pnt Adj.
5	4939M	57	156941	Retainer Spring	Pin Head Rivet
6	178024	91	180535	Sway Bar	Bracket, Asm Noseroller, RH
8	174365	94	176066	Bolt 7/16 Asm. Blade	Noseroller
		95	180534	(The following blades are	Bracket, Asm Noseroller, LH
		97	178515	available)	Washer Hardened
11	180054	98	179479	Blade, 48" Hi-Lift	Spring Primary Drive
13	174360	99	189993	Shaft Asm. w/Lower Bearing	Pulley Idler"V"
14	174358	100	72110616	Mandrel Asm.	Bolt RDHD Sqnk 3/8-16 Unc x 2
15	110485X	110	175016	Bearing, Ball, Mandrel	Arm Spring Secondary
16	174493	112	174387	Stripper Mandrel Deck	Link Tension Relief Lever
17	72110610	113	72110506	Bolt RDHD Sq Neck 3/8-16x1.25	Bolt 5/16-18 x 3/4
18	72140505	114	174384	Bolt, Carriage 5/16-18 x 5/8	Tension Asm. Relief Lever
19	132827	115	174609	Bolt, Hex Hd, Shoulder 5/16-18	Arm Spring Tension Relief
20	174378	116	193406	Baffle, Vortex Mower	Bolt, Shoulder
21	73680500	117	174873	Nut, Crownlock 5/16-18 Unc	Gauge Wheel
24	105304X	118	73930600	Cap, Sleeve	Nut, Centerlock 3/8-16 Unc
25	178102	119	19121414	Spring, Torsion	Washer 3/8 x 7/8 x 14 Ga.
26	110452X	121	174371	Nut, Push	Spring Secondary Drive
27	180655X428	122	174606	Deflector Shield	Bushing Pivot Tension Relief
28	19111016	126	174372	Washer 11/32 x 5/8 x 16 Ga.	Arm, Idler, Primary Deck
29	131491	130	17000616	Rod, Hinge	Screw 3/8-16 x 1.0
30	173984	132	17000612	Screw, Thdroll Washer Head	Screw 3/8-16 x .75
31	187690	180	73800500	Washer, Spacer	Nut Lock Hex w/Inc. 5/16-18 unc
32	153535	182	179127	Pulley, Mandrel	Rod Roller Nose
33	178342	183	163552	Nut, Fig. Top Lock Cntr. 9/16	Retainer Spring
37	177968	184	173979	Pulley, Idler, Flat	Keeper Belt Idler
39	174375	--	174356	Pulley, Idler, Driven	Mandrel Assembly
42	165723			Spacer, Retainer	(Includes Key Nos. 13-15 and 33)
43	174373	--	181579	Arm, Idler Secondary	Replacement Mower, Complete
45	180806			Cover, Mandrel Deck	
46	137729			Screw, Thdroll. 1/4-20 x 5/8	
47	180808			V-Belt, Mower, Secondary	
48	174368			V-Belt, Mower, Primary	
49	73900600			Nut, Lock 3/8-16 Unc	
50	72110612			Bolt, Carr. 3/8-16 x 1-1/2 Gr. 5	

NOTE: All component dimensions given in U. S. inches 1 inch = 25.4 mm

TRACTOR -- MODEL NUMBER 917.276320
TRANSAXLE--MODEL NUMBER 331-3000

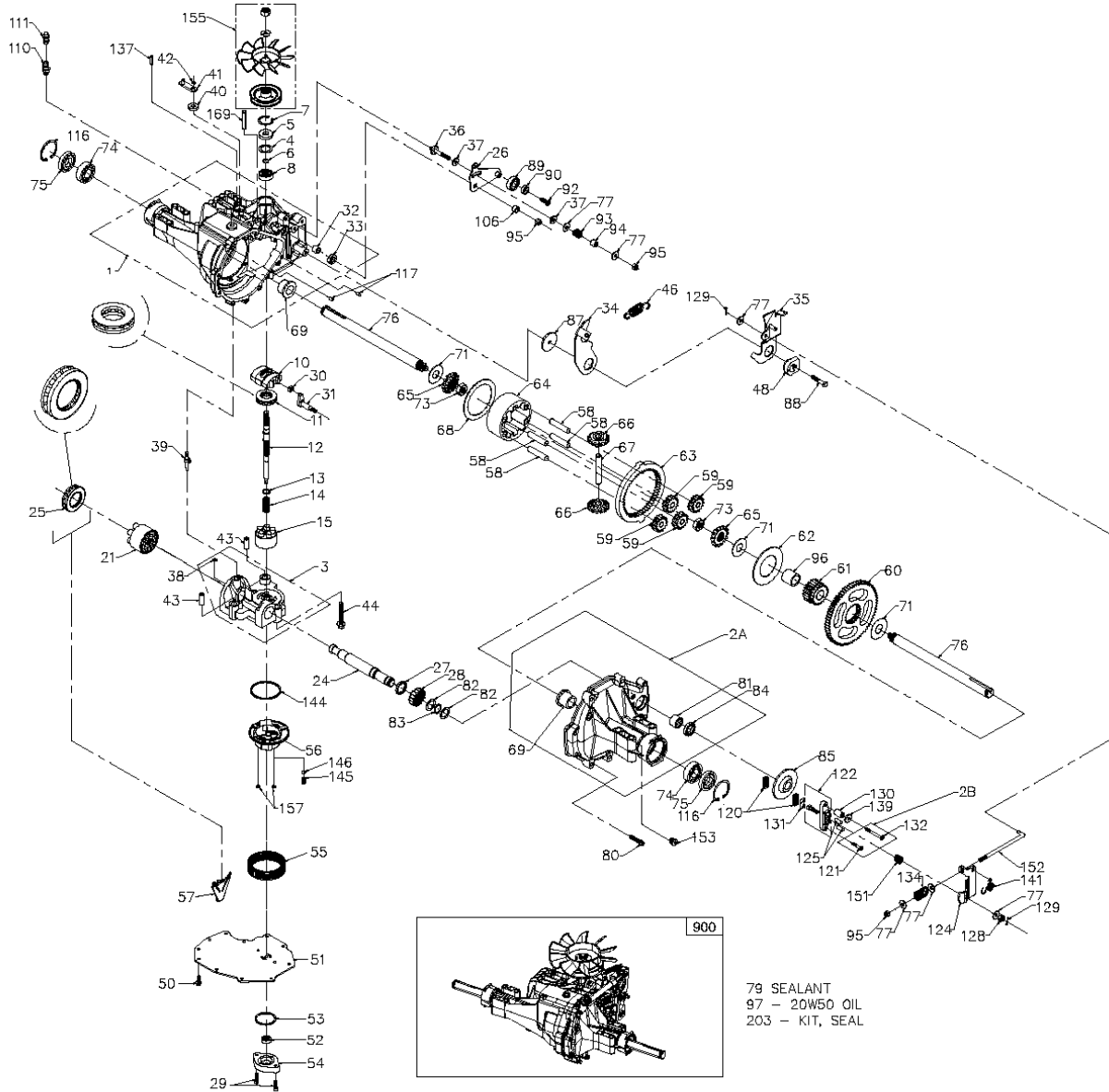

TRACTOR -- MODEL NUMBER 917.276320
TRANSAXLE--MODEL NUMBER 331-3000

Key No.	Part No.	Description	Key No.	Part No.	Description
1	161122	Kit, housing main	65	161150	Gear, differential bevel (310-3000)
		Main housing	66	161151	Gear, differential bevel pinion (310-3000)
		Lip seal			
		Flange bearing	67	161152	Shaft, differential (310-3000)
		Trunnion bushing	68	161153	Plate, differential thrust (310-3000)
		Cradle bearing	69	169534	Bearing, flange (310-3000)
2A	193015	Kit, housing r/h	71	161155	Washer, flat (1.00 Id) (310-3000)
		R.H. Housing	73	161156	Nut, 5/8-18 hex jam (310-3000)
		Flange bearing	74	169535	Bearing, ball (310-3000)
		Needle bearing (sce1412)	75	161157	Seal, lip (310-3000)
		Lip seal (.875 ID x 1.3 OD x .25)	76	161158	Shaft, axle (310-3000)
2B	193016	Kit, brake bolt	77	142884	Washer, flat
		Bolt, hex hd 1/4-20 x 1.25 W/patch	79	178322	Sealant tube
		Bolt, hex hd 1/4-20 x 2.25 W/patch	80	161159	Screw, torx head 5/16-18 (310-3000)
3	184703	Kit, center section	81	161160	Bearing, needle (210-3000)
		Center section	82	161161	Washer, flat (0.880 ID) (310-3000)
		Bushing .50 X .60 X .50	83	161162	Ring, retaining (310-3000)
		Bushing .90 X 1.02 X .75	84	161163	Seal, lip (.875 ID x 1.38 OD x .25) (310-3000)
		Plate, bypass			
		Check plug assembly,.044	85	161164	Brake disc (310-3000)
		Check plug assembly, no bleed	87	178323	Washer (310-3000)
4	161125	Spacer (BDP, BDU 10)	88	178784	Screw, 5/16-24x 1 1/2 socket head cap (310-3000)
5	142932	Seal, lip			
6	142928	Retaining ring	89	178783	Bearing, ball
7	142933	Retaining ring	90	178326	Spacer, locating (310-3000)
8	142934	Bearing, ball	92	178787	Screw (310-3000)
10	169524	Swash plate (BDP, BDU 10)	93	142969	Spring
11	173159	Bearing, thrust (10cc)	94	142980	Spacer
12	161126	Shaft, input (310-3000)	95	169537	Nut, nylon insert hex lock 5/16-24
13	142978	Washer, block thrust	96	169538	Bearing, sleeve (310-3000)
14	142977	Spring, helical compression	97	-----	20W-50 oil 122 oz
15	169898	Kit, cylinder block (10cc)	106	161166	Spacer, trunnion (310-3000)
		10CC cylinder block	108	150800	Plug, plastic shipping
		10CC piston	110	150813	O-ring
		10CC piston spring			Fitting, plastic hose
		Piston seat washer			O-ring
21	150786	Block, (BD-21& IHT)	111	150812	Breather vent, plastic
		21CC Cylinder block			Vent, plastic
		Piston seat washer			Vent, cap
		21CC piston	116	169539	Ring, retaining (310-3000)
		21CC piston spring	117	161168	Pin
24	161127	Shaft, motor (310-3000)	120	142883	Brake puck
25	169526	Bearing, thrust (21cc)	121	193019	Bolt, hex hd 1/4-20 x 1.25 W/patch
26	161128	Control arm (310-3000)	122	178329	Kit, brake yoke
27	161129	Spacer (310-3000)	124	178330	Brake arm
28	161130	Gear, 16t pinion	125	170409	Pin, brake actuating
29	169527	Capscrew	128	170415	Nut, castle 5/16-24
30	142941	Guide block (BD-21)	129	170416	Pin, cotter 3/32x3/4
31	169887	Trunnion, tapered square	130	170411	Spacer, brake torsion spring
32	161133	Bearing, journal	131	142882	Brake puck plate
33	142940	Seal, lip	132	193020	Bolt, hex hd 1/4-20 x 2.25 W/patch
34	178318	Return arm (310-3000)	134	178331	Brake comp. Spring
35	178319	Actuating arm (310-3000)	137	178333	Pin, spring (310-3000)
36	170421	Bolt, stud 5/16-24	139	161176	Washer, flat
37	142967	Friction puck	141	178335	Spring, brake arm bias
38	184694	Kit, bypass plate	144	169545	O-ring
39	169529	Bypass actuator (IHT)	145	169546	Spring, relief
40	142945	Seal, lip	146	169547	Steel ball 7/16
41	142952	Bypass arm	151	170417	Brake spring
42	142953	Retaining ring	152	178336	Brake pull rod
43	142965	Pin	153	170434	Plug, straight thread 9/16-18
44	150797	Bolt 3/8-24 x 2-1/2	155	178337	Kit, fan/pulley
46	184702	Spring, neutral (310-3000)			Nut, jam 1/2-20
48	178320	Puck, adjusting (310-3000)			Washer, OD slotted .53 X 1.63 X .06
50	178343	Screw, hex head washer cap screw (IZT) 1/4-20 x 3/4			Pulley
51	169530	Lower cover	157	169548	Fan
52	169531	Geroter assembly	169	184701	O-ring
53	144581	O-ring	203	178338	Pin, spring 5/16 x 1.75
54	161139	Charge pump housing			Kit, seal
55	178321	Kit, filter			Lip seal 15 x 5 x 37
		Gasket .10 X .16 X 4.24			Lip seal 12 x 25 x 7
		Filter			Lip seal 10 x 25 x 7
56	169533	Charge manifold 310-3000			O-ring .103 X 1.862
57	161142	Retainer, motor bearing (310-3000)			Seal 25 x 52 x 10
58	161143	Pin, carrier (310-3000)			Lip seal .875 ID x 1.3 OD x .25
59	161144	Gear, 15t planet (310-3000)			O-ring .070 X .239
60	161145	Gear, 67t spur (310-3000)			Kit, o-ring, manifold
61	161146	Gear, 21t sun (310-3000)			Pin, spring 5/16 x 1.75
62	161147	Plate, planet thrust (310-3000)	900	176056	Pin, spring 1/4 x 1.00
63	161148	Gear, 51t ring (310-3000)			Transaxle
64	161149	Carrier, planetary (310-3000)			

Note: All Component Dimensions Given in U.s. Inches
1 Inch = 25.4 MM

**TRACTOR -- MODEL NUMBER 917.276320
BRIGGS ENGINE-MODEL NUMBER 446677, TYPE NUMBER 0470-E1**

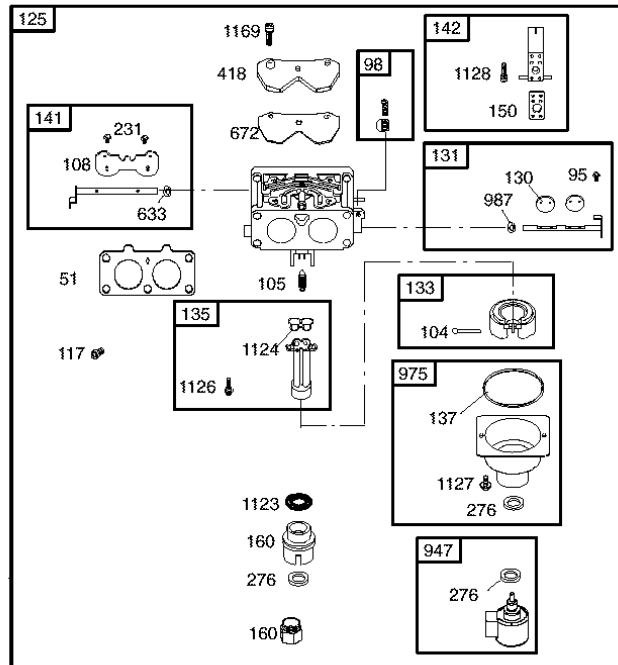
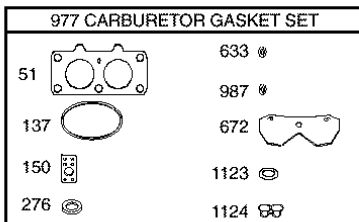
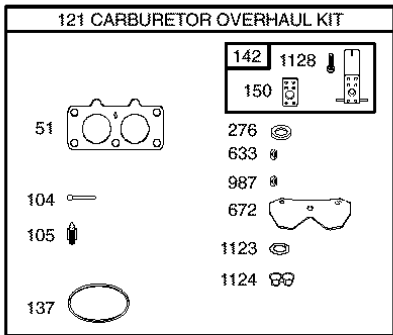
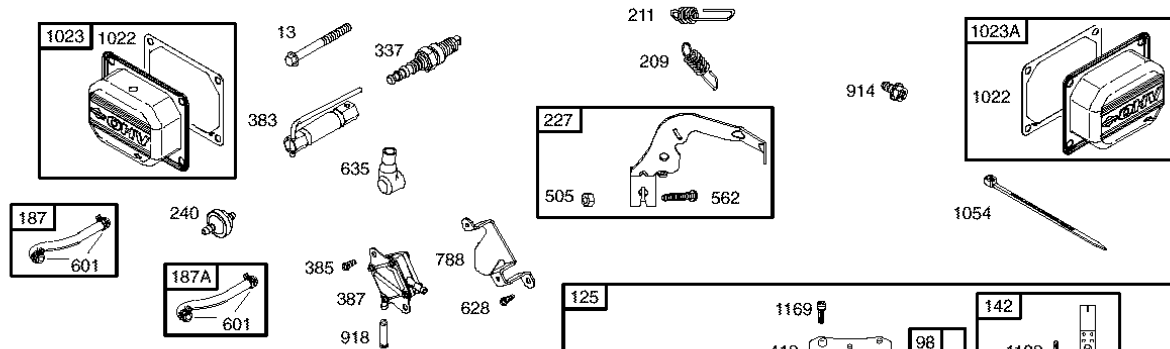
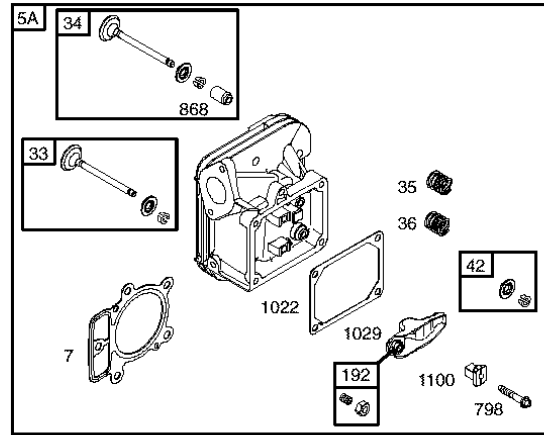
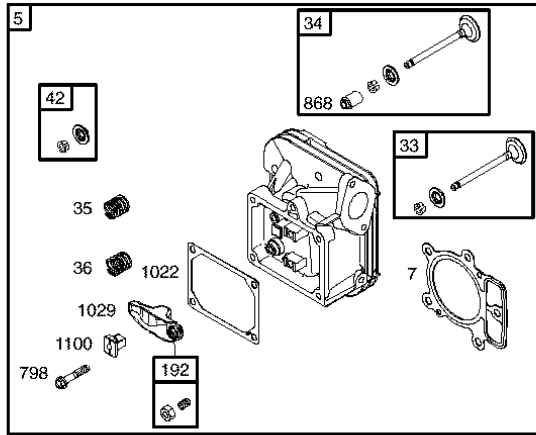

**TRACTOR -- MODEL NUMBER 917.276320
BRIGGS ENGINE-MODEL NUMBER 446677, TYPE NUMBER 0470-E1**

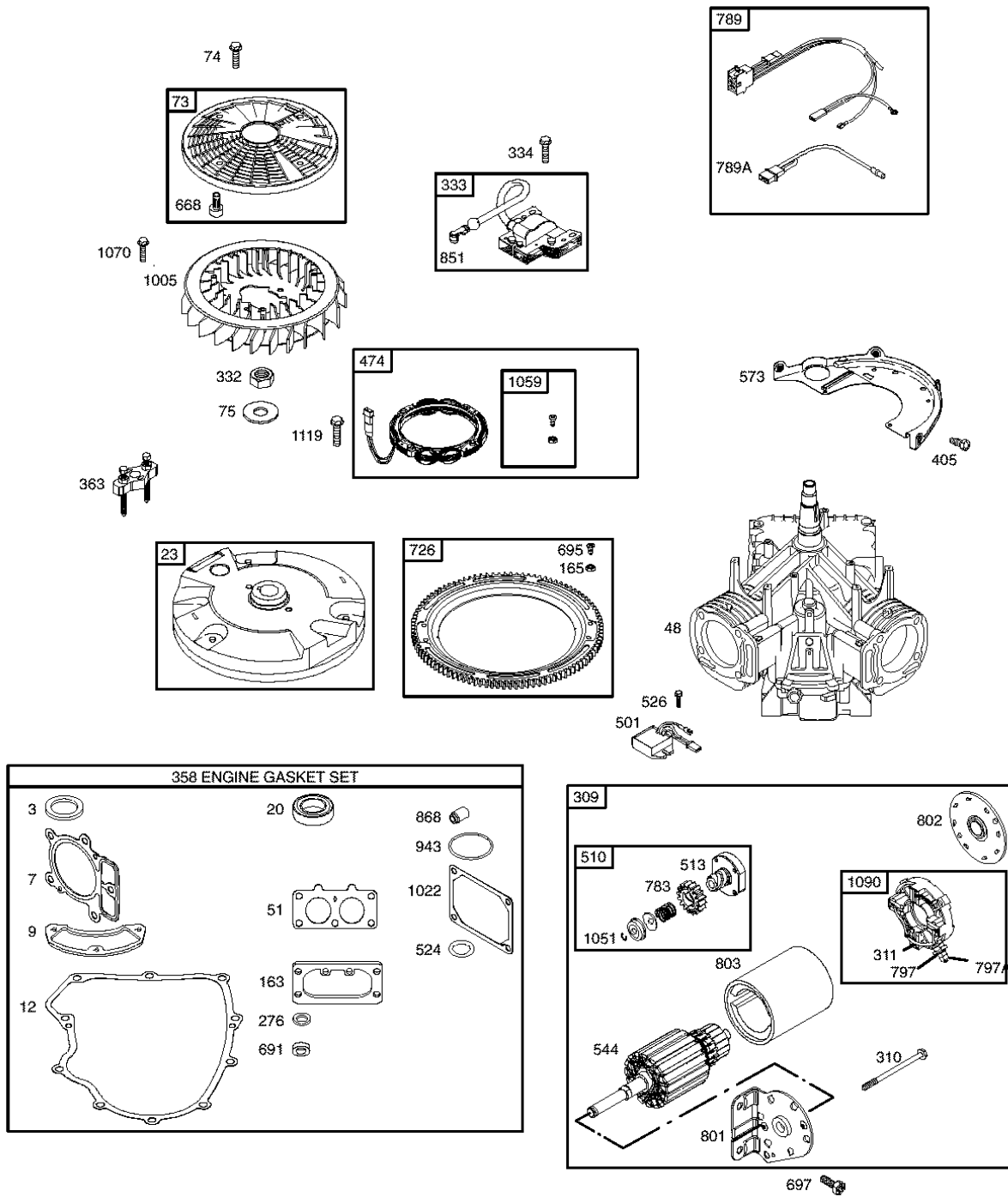

**TRACTOR -- MODEL NUMBER 917.276320
BRIGGS ENGINE-MODEL NUMBER 446677, TYPE NUMBER 0470-E1**

KEY NO.	PART NO.	DESCRIPTION	KEY NO.	PART NO.	DESCRIPTION
1	699753	Cylinder Assembly	133	499803	Float-Carburetor
2	499585	Kit-Bushing/Seal (Magneto Side)	135	699729	Tube-Fuel Transfer
3	391086	• Seal-Oil (Magneto Side)	137	690994	Ø‡ Gasket-Float Bowl
4	699747	Sump-Engine	141	499807	Kit-Choke Shaft
5	697580	Head-Cylinder (Cylinder 1)	142	499808	Ø Nozzle-Carburetor
5A	697581	Head-Cylinder (Cylinder 2)	146	690979	Key-Timing
7	693997	•• Gasket-Cylinder Head	150	690995	Ø‡ Gasket-Nozzle
8	499601	Breather Assembly	160	690996	Retainer-Solenoid
9	690937	• Gasket-Breather	163	691001	•• Gasket-Air Cleaner
10	691108	Screw (Breather Assembly)	165	693148	Nut (Ring Gear)
11	690942	Tube-Breather	187	698472	Line-Fuel (Molded)
12	697227	• Gasket-Crankcase	187A	691049	Line-Fuel (Molded)
13	791130	Screw (Cylinder Head)	188	691108	Screw (Control Bracket)
15	690946	Plug-Oil Drain	192	690083	Adjuster-Rocker Arm
16	790132	Crankshaft	209	697674	Spring-Governor
20	690947	• Seal-Oil (PTO Side)	211	691019	Spring-Governed Idle
22	694966	Screw (Engine Sump)	212	695238	Link-Throttle
23	691053	Flywheel	213	691021	Bracket-Choke Control
24	222698	Key-Flywheel	216	691022	Link-Choke
25	697679	Piston Assembly (Standard)	219	698231	Gear-Governor
25	697681	Piston Assembly (.020" Over-size)	220	690412	Washer (Governor Lever)
26	697683	Ring Set-Piston (Standard)	222	698761	Bracket-Control
26	697685	Ring Set-Piston (.020" Over-size)	227	691048	Lever-Governor Control
27	690975	Lock-Piston Pin	231	690718	Screw (Choke Valve)
28	690229	Pin-Piston	240	695666	Filter-Fuel
29	699699	Rod-Connecting	250	690957	Retainer-Breather
32	690976	Screw (Connecting Rod)	252	690956	Collector-Oil
33	697576	Valve-Exhaust	265	691024	Clamp-Casing
34	499597	Valve-Intake	267	695134	Screw (Casing Clamp)
35	690963	Spring-Valve (Intake)	276	690997	•Ø‡ Washer-Sealing
36	690963	Spring-Valve (Exhaust)	287	691108	Screw (Dipstick Tube)
42	499586	Keeper-Valve	304	698073	Housing-Blower
45	690977	Tappet-Valve	305	691005	Screw (Blower Housing)
46	790562	Camshaft	309	691262	Motor-Starter
48	698173	Short Block	310	691263	Bolt-Starter Motor
50	695241	Manifold-Intake	311	497608	Brush Set
51	690950	•Ø‡ Gasket-Intake	332	691059	Nut (Flywheel)
53	690951	Stud (Carburetor)	333	691060	Armature-Magneto
54	699816	Screw (Intake Manifold)	334	691061	Screw (Magneto Armature)
73	494439	Screen-Rotating	337	491055	Spark Plug
74	698425	Screw (Rotating Screen)	358	694012	Set-Engine Gasket
75	691056	Washer (Flywheel)	363	19203	Flywheel Puller
89	690283	Plug-Oil	383	19374	Wrench-Spark Plug
95	690718	Screw (Throttle Valve)	385	691108	Screw (Fuel Pump)
98	499802	Kit-Idle Speed	387	808656	Pump-Fuel
104	690984	Ø Pin-Float Hinge	404	690442	Washer (Governor Crank)
105	690985	Ø Valve-Float Needle			
108	690986	Valve-Choke			
117	690986	Jet-Main (Standard)			
118	690989	Jet-Main (High Altitude)			
121	499811	Kit-Carburetor Overhaul			
125	499804	Carburetor			
130	690993	Valve-Throttle			
131	499805	Kit-Throttle Shaft			

• Included in Engine Gasket Set, Key. No. 358
 Ø Included in Carburetor Overhaul Kit, Key. No. 121
 ‡ Included in Carburetor Gasket Set, Key. No. 977
 + Included in Valve Gasket Set, Key. No. 1095

NOTE: All component dimensions given in U.S. inches 1 inch = 25.4 mm

**TRACTOR -- MODEL NUMBER 917.276320
BRIGGS ENGINE-MODEL NUMBER 446677, TYPE NUMBER 0470-E1**

KEY NO.	PART NO.	DESCRIPTION	KEY NO.	PART NO.	DESCRIPTION
405	697820	Screw (Back Plate)	865B	691015	Cover-Air Guide
418	690999	Plate-Carburetor	868	690968	•+ Seal-Valve
445	698754	Filter-Air Cleaner Cartridge	914	691127	Screw (Rocker Cover)
447	691003	Screw (Air Guide Cover)	918	694000	Hose-Vacuum
447A	691108	Screw (Air Guide Cover)	929	695239	Screw (Choke Control Bracket)
474	696458	Alternator	943	690589	• Seal-O Ring (Oil Pump Cover)
501	691185	Regulator	947	499809	Solenoid-Fuel
505	691029	Nut (Governor Control Lever)	965	499613	Cover-Oil Pump
510	497606	Drive-Starter	967	273638	Filter-Pre Cleaner
513	692024	Clutch-Drive	968	790096	Cover-Air Cleaner
523	691036	Dipstick	975	499810	Bowl-Float
524	691032	• Seal-Dipstick Tube	977	694013	Gasket Set-Carburetor
525	691037	Tube-Dipstick	987	691000	Ø‡ Seal-Throttle Shaft
526	691108	Screw (Regulator)	1005	698760	Fan-Flywheel
544	----	Armature-Starter (Service with 691262 Starter Motor)	1013	690954	Nipple-Oil Filter
			1017	690770	Screen-Oil Pump
552	690552	Bushing-Governor Crank	1019	790094	Kit-Label
552A	690553	Bushing-Governor Crank	1022	690971	•+ Gasket-Rocker Cover
562	690311	Bolt (Governor Control Lever)	1023	499599	Cover-Rocker (Cylinder 1)
573	691009	Plate-Back	1023A	499600	Cover-Rocker (Cylinder 2)
601	691038	Clamp-Hose	1024	499054	Pump-Oil
615	698290	Retainer-Governor Shaft	1026	690981	Rod-Push (Steel)
616	691045	Crank-Governor	1026A	690982	Rod-Push (Aluminum)
628	691108	Screw (Fuel Pump Bracket)	1027	696854	Filter-Oil
633	690998	Ø‡ Seal-Choke/Throttle Shaft	1029	690972	Arm-Rocker
635	66538	Boot-Spark Plug	1035	691042	Shaft-Pump
654	690958	Nut (Carburetor)	1036	790626	Label-Emission
668	691215	Spacer	1051	691265	Ring-Retaining
672	690234	Ø‡ Gasket-Carburetor Plate	1054	280275	Cable-Tie
691	690657	• Seal-Governor Shaft	1058	275475	Owner's Manual
695	693149	Screw (Ring Gear)	1059	698516	Kit-Screw/Washer
697	690372	Screw (Drive Cap)	1070	690372	Screw (Flywheel Fan)
703	691010	Clip	1090	691293	Retainer-Brush
718	690959	Pin-Locating	1095	694013	Gasket Set-Valve
726	499612	Gear-Ring	1100	690973	Pivot-Rocker Arm
741	690980	Gear-Timing	1119	691183	Screw (Alternator)
742	690328	Retainer-E Ring	1123	690987	Ø‡ Seal-O Ring (Solenoid Retainer)
750	696999	Screw (Oil Pump Cover)			
783	693058	Gear-Pinion	1124	690988	Ø‡ Seal-O Ring (Fuel Transfer Tube)
788	691039	Bracket-Fuel Pump			
789	698330	Harness-Wiring	1126	690991	Screw (Fuel Transfer Tube)
789A	790544	Harness-Wiring	1127	690992	Screw (Float Bowl)
797	691029	Nut (Brush Retainer)	1128	690990	Screw (Carburetor Nozzle)
797A	693167	Nut (Brush Retainer)	1169	693140	Screw (Carburetor Cover Plate)
798	697890	Screw (Rocker Arm)			
801	691283	Cap-Drive	1267	698440	Latch-Blower Housing
802	691286	Cap-End	1329	446777-0126	Replacement Engine (Transfer 6 pin and Exhaust)
803	----	Housing-Starter (Service with 691262 Starter Motor)	1330	273521	Repair Manual
842	691031	• Seal-Dipstick/Tube			
847	499602	Dipstick/Tube Assembly	•		Included in Engine Gasket Set, Key. No. 358
851	493880	Terminal-Spark Plug	Ø		Included in Carburetor Overhaul Kit, Key. No. 121
855	698072	Adapter-Air	‡		Included in Carburetor Gasket Set, Key. No. 977
865	691012	Cover-Air Guide	+		Included in Valve Gasket Set, Key. No. 1095
865A	691014	Cover-Air Guide			

NOTE: All component dimensions given in U.S. inches 1 inch = 25.4 mm

SUGGESTED GUIDE FOR SIGHTING SLOPES FOR SAFE OPERATION

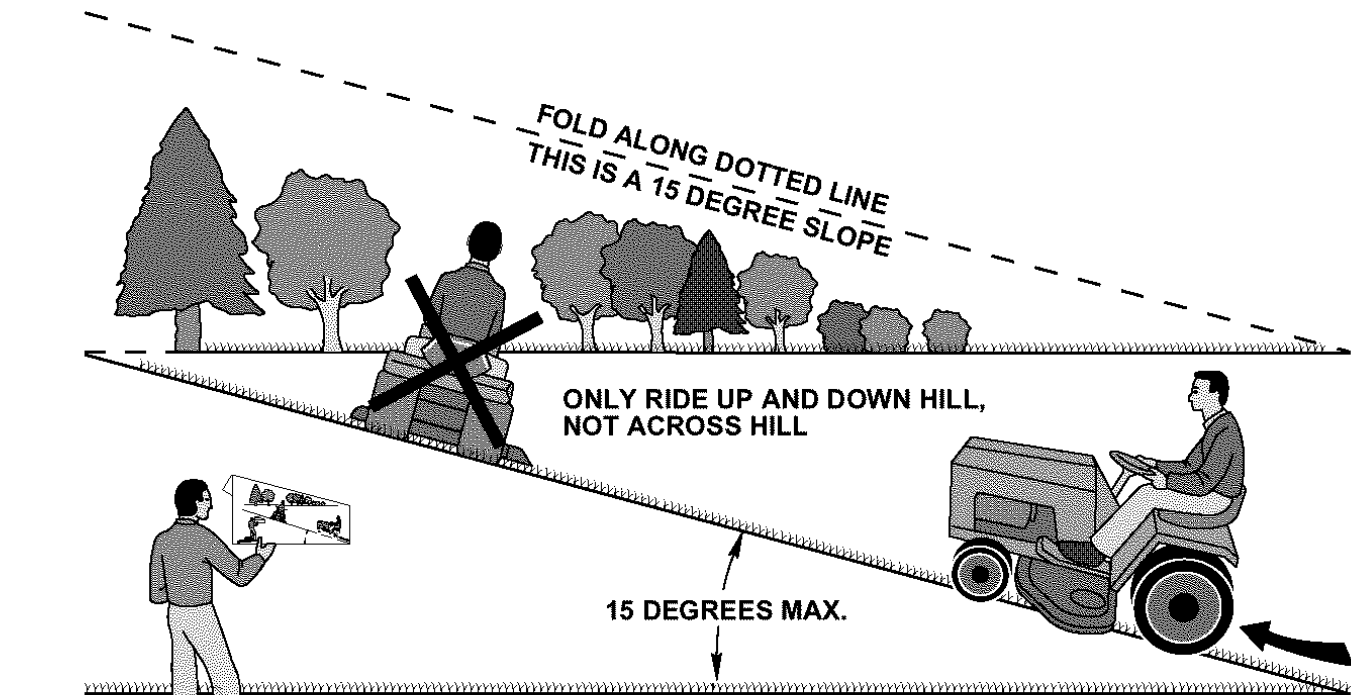

WARNING: To avoid serious injury, operate your tractor up and down the face of slopes, never across the face. Do not mow slopes greater than 15 degrees. Make turns gradually to prevent tipping or loss of control. Exercise extreme caution when changing direction on slopes.

1. Fold this page along dotted line indicated above.
2. Hold page before you so that its left edge is vertically parallel to a tree trunk or other upright structure.
3. Sight across the fold in the direction of hill slope you want to measure.
4. Compare the angle of the fold with the slope of the hill.

Get it fixed, at your home or ours!

Your Home

For repair – **in your home** – of **all** major brand appliances, lawn and garden equipment, or heating and cooling systems, **no matter who made it, no matter who sold it!**

For the replacement parts, accessories and owner's manuals that you need to do-it-yourself.

For Sears professional installation of home appliances and items like garage door openers and water heaters.

1-800-4-MY-HOME[®] Anytime, day or night
(1-800-469-4663) (U.S.A. and Canada)
www.sears.com www.sears.ca

Our Home

For repair of carry-in products like vacuums, lawn equipment, and electronics, call or go on-line for the nearest **Sears Parts and Repair Center.**

1-800-488-1222 Anytime, day or night (U.S.A. only)
www.sears.com

To purchase a protection agreement (U.S.A.) or maintenance agreement (Canada) on a product serviced by Sears:

1-800-827-6655 (U.S.A.) **1-800-361-6665** (Canada)

Para pedir servicio de reparación a domicilio, y para ordenar piezas:

1-888-SU-HOGARSM
(1-888-784-6427)

Au Canada pour service en français:

1-800-LE-FOYER^{MC}
(1-800-533-6937)
www.sears.ca



02410

© Sears, Roebuck and Co.

® Registered Trademark / ™ Trademark / SM Service Mark of Sears, Roebuck and Co.

© Marca Registrada / ™ Marca de Fábrica / SM Marca de Servicio de Sears, Roebuck and Co.

^{MC} Marque de commerce / ^{MD} Marque déposée de Sears, Roebuck and Co.