

# **SEARS**

## **OWNER'S MANUAL**

**MODEL NO.**  
390.2514  
390.2518

**CAUTION:**  
Read and Follow  
All Safety Rules and  
Operating Instructions  
Before First Use of  
This Product.

**Save This Manual For  
Future Reference.**

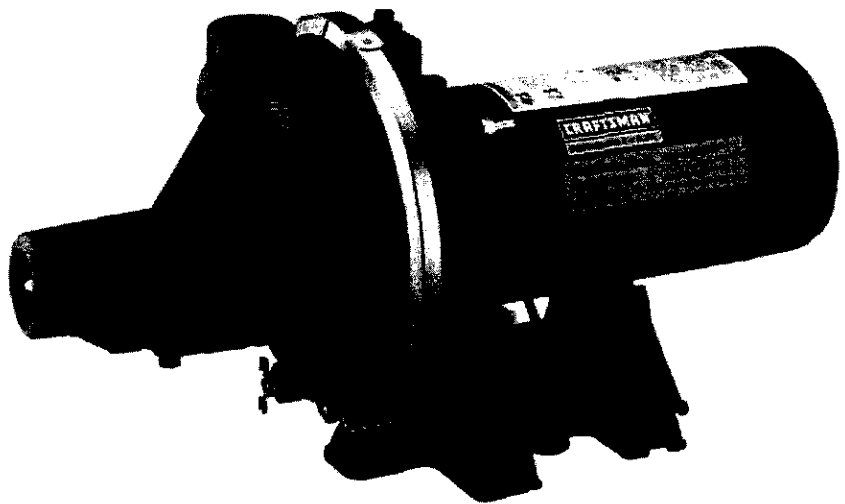

# **CRAFTSMAN<sup>®</sup> PROFESSIONAL “HYDROGLASS”<sup>®</sup> SHALLOW WELL JET PUMP**

- Safety Instructions
- Installation
- Operation
- Troubleshooting
- Repair Parts

**Sears, Roebuck and Co., Hoffman Estates, IL 60179 U.S.A.**

# READ AND FOLLOW SAFETY INSTRUCTIONS!



**⚠ DANGER**

**⚠ WARNING**

**⚠ CAUTION**

This is the safety alert symbol. When you see this symbol on your pump or in this manual, look for one of the following signal words and be alert to the potential for personal injury:

**DANGER** warns about hazards that **will** cause serious personal injury, death or major property damage if ignored.

**WARNING** warns about hazards that **will** or **can** cause serious personal injury, death or major property damage if ignored.

**CAUTION** warns about hazards that **will** or **can** cause minor personal injury or property damage if ignored.

The label **NOTICE** indicates special instructions which are important but not related to hazards.

**Carefully read and follow all safety instructions in this manual and on pump.**

Keep safety labels in good condition.

Replace missing or damaged safety labels.

Relief valve must be capable of passing full pump flow at 75 PSI.

Pump water only with this pump.

## Electrical Safety

**⚠ WARNING**

**Hazardous voltage. Can shock, burn, or cause death.**

Ground pump before connecting to power supply.

**⚠ Wire motor for correct voltage. See "Electrical" section of this manual and motor nameplate.**

**⚠ Ground motor before connecting to power supply.**

**⚠ Meet National Electrical Code and local codes for all wiring.**

**⚠ Follow wiring instructions in this manual when connecting motor to power lines.**

Make workshops childproof; use padlocks and master switches; remove starter keys.

## General Safety

Do not allow pump, pressure tank, piping, or any other system component containing water to freeze. Freezing may damage system, leading to injury or flooding. Allowing pump or system components to freeze will void warranty.

## General Safety

**⚠ WARNING**

**Hazardous pressure! Install pressure relief valve in discharge pipe.**

Release all pressure on system before working on any component.

Periodically inspect pump and system components.

Wear safety glasses at all times when working on pumps.

Keep work area clean, uncluttered and properly lighted; store properly all unused tools and equipment.

Keep visitors at a safe distance from the work areas.

**⚠ WARNING** Pump body may explode if used as a booster pump unless relief valve capable of passing full pump flow at 75 PSI (517 kPa) is installed.

**⚠ CAUTION** Motor normally operates at high temperature and will be too hot to touch. It is protected from heat damage during operation by an automatic internal cutoff switch. Before handling pump or motor, stop motor and allow it to cool for 20 minutes.

**TABLE I – PUMP PERFORMANCE** (In Gallons per Minute)

Model No.	Description	Suct.	Disch.	Discharge Pressure PSI	Pumping Depth in Feet			
					5'	10'	15'	20'
390.2514	1/2 HP S.W. Jet	1-1/4"	1"	40	8.2	7.3	6.2	5.0
390.2518	3/4 HP S.W. Jet	1-1/4"	1"	40	10.9	10.4	8.6	7.5

# CONTENTS

Safety .....	2
Warranty/Introduction .....	3
Pump Performance .....	3
Major Components .....	3-4
Piping .....	4
Electrical .....	5-6
Installation .....	7
Operation .....	7
Maintenance .....	8-9
Helpful Hints .....	9
Repair Parts .....	10-11
Troubleshooting Guide .....	12

# INTRODUCTION

We suggest you take a few minutes to read the instructions contained in this manual before installing and using your pump. This will help you obtain the full benefits of the quality and convenience built into this equipment. It will also help you avoid any needless service expense resulting from causes beyond our control which naturally cannot be covered in our warranty.

## **FULL ONE YEAR WARRANTY ON CRAFTSMAN® WELL PUMPS**

For one year from the date of purchase, Sears will repair or replace this pump, free of charge, if defective in material or workmanship.

## **LIMITED WARRANTY ON CRAFTSMAN® PROFESSIONAL HYDROGLASS® WELL PUMPS**

After one year and through three years from the date of purchase, Sears will furnish, free of charge, a replacement part for any defective part. You pay for labor.

## **LIMITED WARRANTY ON CRAFTSMAN® HYDROGLASS® WELL PUMP**

After one year and through two years from the date of purchase, Sears will furnish, free of charge, a replacement part for any defective part. You pay for labor.

This warranty does not cover repairs or replacement parts necessary because of abuse or negligence including failure to install, adjust and operate this pump according to the instructions in the owner's manual.

### **LIMITATION OF LIABILITY**

SEARS WILL NOT BE LIABLE FOR LOSS OR DAMAGE TO PROPERTY OR ANY INCIDENTAL OR CONSEQUENTIAL LOSS OR EXPENSE FROM PROPERTY DAMAGE DUE DIRECTLY OR INDIRECTLY FROM THE USE OF THIS PRODUCT.

Some states do not allow the exclusion or limitation of incidental or consequential damages, so the above limitation or exclusion may not apply to you.

WARRANTY SERVICE IS AVAILABLE BY SIMPLY CONTACTING THE NEAREST SEARS SERVICE CENTER/DEPARTMENT IN THE UNITED STATES.

This warranty applies only while the product is in use in the United States.

This warranty gives you specific legal rights, and you may also have other rights which vary from state to state.

**Sears, Roebuck and Co., Dept. 817 WA, Hoffman Estates, IL 60179**

# RULES FOR SAFE INSTALLATION AND OPERATION

1. Read the Owners Manual and Rules for Safe Operation and Installation Instructions carefully. Failure to follow these Rules and Instructions could cause serious bodily injury, and/or property damage.
2. Check your local electrical wiring codes before installation. If your local codes are not followed, your pump will not work to its full rated capacity. If in doubt, contact your local Power Company.
3. Be certain your pump installation meets all local plumbing, pump and well codes.
4. While installing the pump, always keep the well covered to prevent leaves and foreign matter from falling into the well and contaminating the water and/or causing possible serious damage to the mechanical operation of the pump.
5. Always test the well water for purity before using. Check with local health department for testing procedure.
6. Before installing or servicing your pump, BE CERTAIN pump power source is disconnected.
7. Be sure your pump electrical circuit is properly grounded.
8. Complete pump and piping system MUST be protected against below freezing temperature. Failure to do so could cause severe damage and voids the Warranty.
9. Make sure the line voltage and frequency of the electrical circuit supply agree with the motor wiring. If motor is dual voltage type, BE SURE it is wired correctly for your power supply.
10. The correct fusing and wiring sizing is essential to proper motor operation. Recommended fusing and wire size data is in the manual.

# MAJOR COMPONENTS / PIPING

## MAJOR COMPONENTS AND WHAT THEY DO

**NOTICE:** Use Teflon tape supplied with the pump for making all threaded connections to the pump.

### Impeller and Jet

Impeller turns with motor shaft, causing water to fly out from its rim by centrifugal force. Impeller rotation creates a vacuum which pulls in more water. Part of the water is diverted back to the jet where it passes through the nozzle and venturi. This creates more vacuum to draw in more water.

In shallow wells (less than 20 feet deep), the vacuum created at the pump is enough to pull water to the pump. Therefore, the jet assembly is built into the pump.

### Air Volume Control

The air volume control (AVC) maintains the cushion of air in Standard tanks.

### Pressure Switch

The pressure switch provides automatic control.

MODEL NO.	PUMP STARTS AT	PUMP STOPS AT
390.2514	40 PSI	60 PSI
390.2518	40 PSI	60 PSI

### Tank

The tank serves two functions. It provides a reservoir of water, some of which can be drawn through the house fixture before the pump must start. It maintains a cushion of air under pressure.

Two types of tanks are available. Captive Air® and Standard. No air volume control is needed with Captive Air® Tanks.

## PIPING IN THE WELL

A shallow well jet pump can be installed on a dug well, drilled well or a driven point. SEARS shallow well jet pumps have a built-in check valve. In a dug or cased well, a foot valve and strainer should be installed for easy priming. It should be 5 to 10 feet below the lowest level to which the water will drop while pump is operating (pumping level) (Figure 1).

The strainer should not be too close to the bottom, or sediment may clog it. Before installing foot valve, check to see that it works freely.

When using a foot valve, a priming tee and plug must be included (Figure 2).

Be sure the vertical distance (lift) from the priming level to pump is not over 20 feet, if the pump is over well. This will be less if pump is offset from the well. Both figures are for sea level. The maximum lift of any pump decreases with the elevation above sea level. This decrease is at the rate of 1 foot per 1000 feet of elevation. For example, the lift is 17 feet and your elevation is 3000 feet above sea level. You would then be pumping 17 plus 3, or 20 feet. This is still satisfactory for shallow well pumping.

## EMERGENCY POWER

In some areas and with some installations, an emergency power supply to guard against power failure is a good idea. If you install an engine-generator set for emergency backup power for your pump, supply the generator set manufacturer with the nameplate data from the pump motor. He will then be able to provide a generator of the correct size to power your pump. Also, be sure to add the load from any other accessories (such as lights) that may be on the same circuit.

### Horizontal Piping from Well to Pump

On well point installations where the horizontal piping is more than 25 feet, a check valve should be installed (Figure 3).

When the pump is offset more than 25 feet from the well, horizontal piping should be increased in size to reduce friction losses. Never use offset piping that is smaller than the suction tapping of the pump.

### Horizontal Offset Piping Sizes - Shallow Well Jets

1-1/4"	1-1/2"	2"
Up to 25 ft.	25 to 50 ft.	50 to 200 ft.

### Discharge Pipe Sizes

When the pump is some distance from the house or point of water use, the discharge pipe size should be increased to reduce pressure losses.

1"	1-1/4"	1-1/2"
Up to 25 ft.	25 to 100 ft.	100 to 600 ft.

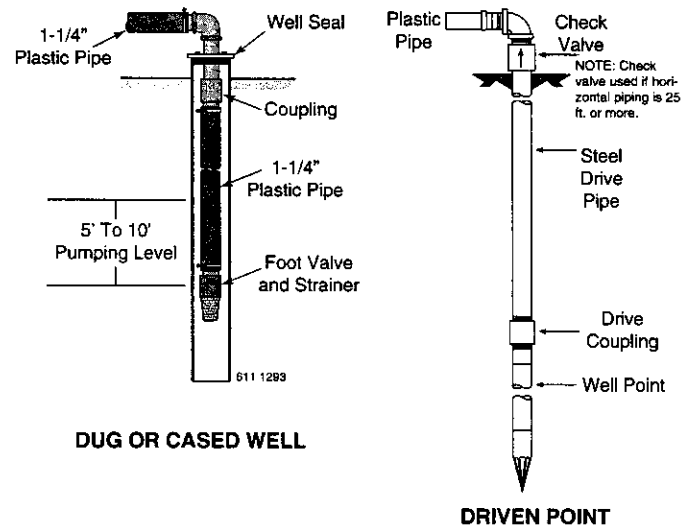

Figure 1

Figure 3

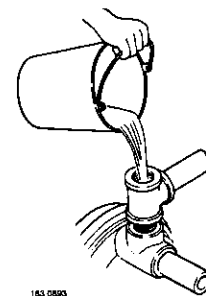

Figure 2

# ELECTRICAL

**⚠ Disconnect power before working on pump, motor, pressure switch, or wiring.**

## Motor Switch Settings

If the motor can operate at either 115 or 230 volts, it is set at the factory to 230 volts. Do not change motor voltage setting if line voltage is 230 volts, or if you have a single voltage motor.

**NOTICE:** Never wire a 115 volt motor to a 230 volt line.

## Remove Motor End Cover

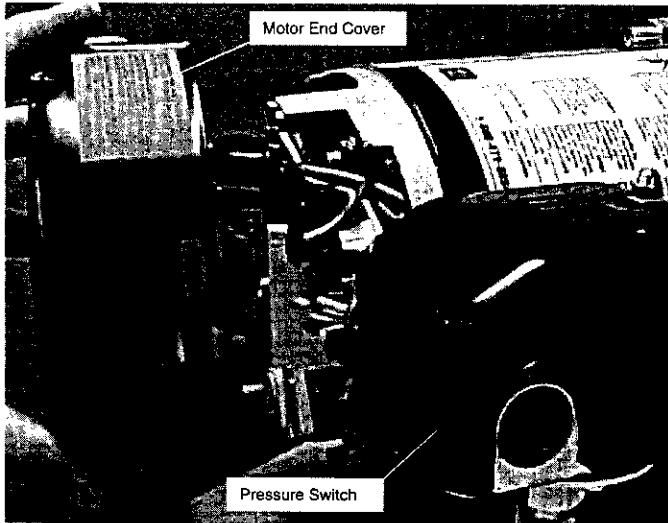
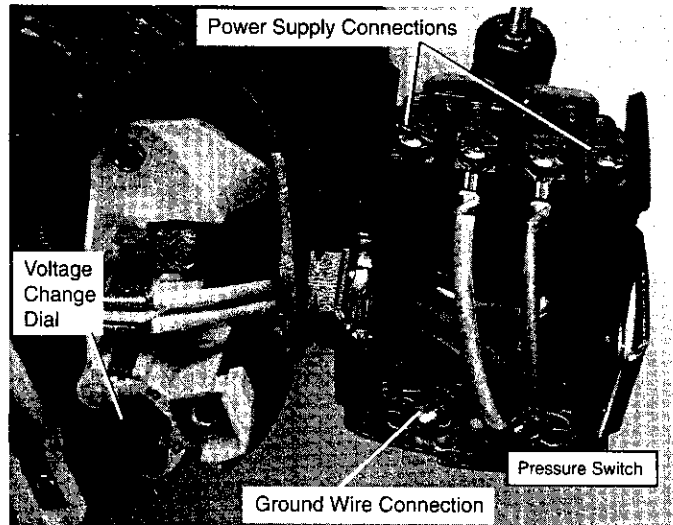

**Figure 4 – Removing Motor End Cover**

You will need to remove the motor end cover to change the voltage setting. The illustration above also shows the pressure switch. If the power supply connection still needs to be made, the pressure switch cover will need to be removed.

Your motor terminal board (located under the motor end cover) should look like the one at right.

## Dial Type Voltage Selector



**Figure 5 – Voltage Set To 230 Volts, Dial Type**

## To change to 115 volts:

1. Make sure power is off.
2. Turn the dial counter-clockwise until 115 shows in the dial window.
3. Reinstall the Motor end cover
4. Go to Wiring Connections, Page 6.

**⚠ WARNING** Hazardous voltage. Can shock, burn, or kill. Connect ground wire before connecting power supply wires. Use the wire size (including the ground wire) specified in the wiring chart. If possible, connect the pump to a separate branch circuit with no other appliances on it.

**⚠ WARNING** Explosion hazard. Do not ground to a gas supply line.

# ELECTRICAL

## WIRING CONNECTIONS

**⚠ WARNING** Fire hazard. Incorrect voltage can cause a fire or seriously damage the motor and voids the warranty. The supply voltage must be within  $\pm 10\%$  of the motor nameplate voltage.

**NOTICE:** Dual-voltage motors are factory wired for 230 volts. If necessary, reconnect the motor for 115 volts, as shown. Do not alter the wiring in single voltage motors.

Install, ground, wire, and maintain your pump in compliance with the National Electrical Code (NEC) or the Canadian Electrical Code (CEC), as applicable, and with all local codes and ordinances that apply. Consult your local building inspector for code information.

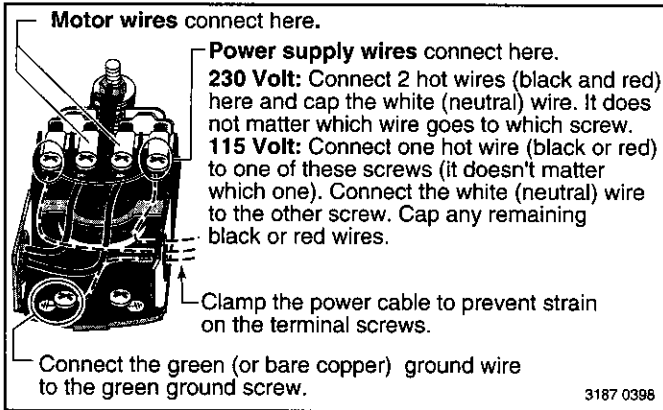

**FIGURE 6 – Pressure switch wiring**

### Connection Procedure:

1. Connect the ground wire first as shown in Figure 9. The ground wire must be a solid copper wire at least as large as the power supply wires.
2. There must be a solid metal connection between the pressure switch and the motor for motor grounding protection. If the pressure switch is not connected to the motor, connect the green ground screw in the switch to the green ground screw under the motor end cover. Use a solid copper wire at least as large as the power supply wires.
3. Connect the ground wire to a grounded lead in a service panel, to a metal underground water pipe, to a metal well casing at least ten feet (3M) long, or to a ground electrode provided by the power company or the hydro authority.
4. Connect the power supply wires to the pressure switch as shown in Figure 6.
5. Reinstall the pressure switch cover.

**TABLE II – RECOMMENDED FUSING AND WIRING DATA**

Pump Model	Motor Horsepower	Volts	Max. Load Amperes	Branch Delayed Fuse Rating Amps	Distance in Feet From Motor to Meter			
					0 to 50	51 to 100	101 to 200	201 to 300
					Wire Size			
390.2514	1/2	115/230	10.5/5.2	15/15	14/14	14/14	10/14	8/14
390.2518	3/4	115/230	12.4/6.2	20/15	12/14	12/14	10/14	8/14

# INSTALLATION / OPERATION

## INSTALLATION

SEARS jet pumps should be used with Captive Air® Tanks (See Figure 7).

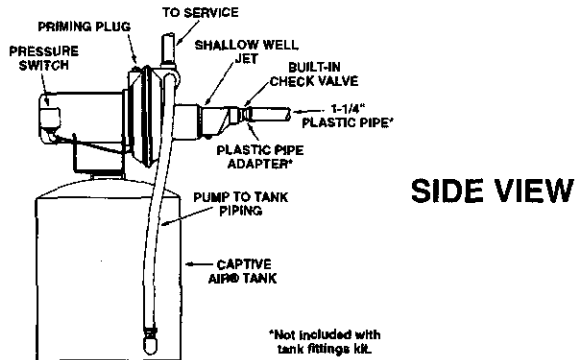

Figure 7

For mounting pump to tank, purchase tank fittings Kit No. 2788. SEARS Captive Air® Tanks are pre-charged at the factory. Check the tank Owners Manual to find if air charge needs adjustment. Model 390.2514 and Model 390.2518 require 40 pounds for proper operation. The jet pump can also be mounted on standard horizontal tanks. A mounting kit with an AVC is furnished with tank. (Figure 8). Instructions are also included.

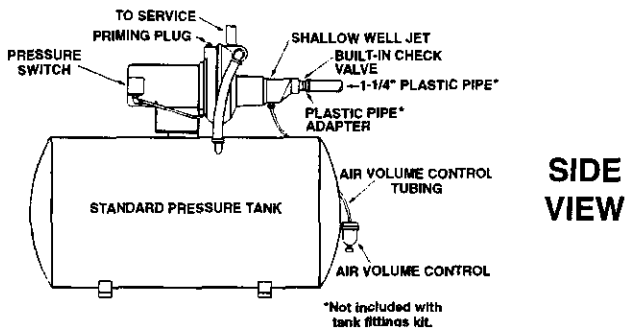

Figure 8

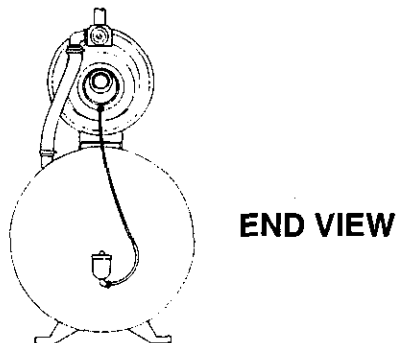

Figure 9

The installation, operation, and care of your Hydroglass® Pump is very similar to cast iron pumps. We ask, however, that you keep the following points in mind.

**NOTICE:** Use Teflon tape supplied with the pump for making all threaded connections to the pump.

**DO NOT USE PIPE JOINT COMPOUND.**

1. Wrap 1-1/2 to 2 turns of Teflon tape to all male pipe threads being attached to the pump. This will insure leakproof connections. Do not overtighten threaded fittings in the plastic pump. If leaks do occur, remove the fitting, replace the Teflon tape, and rewrap with 1-1/2 to 2 turns of Teflon tape and remake the connection.
2. Independently support all piping connected to the Hydroglass® Pump.

## OPERATION

### Priming the Pump

**CAUTION** NEVER run pump dry. Running pump without water may overheat unit, damaging seals and possibly burning persons handling pump.

**WARNING** NEVER run pump against closed discharge. To do so can boil water inside pump, causing hazardous pressure in unit and possibly scalding persons handling pump.

1. Remove priming plug. Fill pump with water. Replace priming plug. If a priming tee and plug have been installed for a long horizontal run, be sure this line is filled and the plug replaced. (Figure 2, Page 4).
2. Start the pump. Water will be pumped in a few minutes; the time depending upon the depth to water and length of horizontal run. If pump does not prime, check for a possible leak in the suction line. Reprime. Check to be sure suction lift - distance from pumping water level to pump - does not exceed 20 feet. See "Piping in the Well" on Page 4.

# SERVICE

## MAINTAINING YOUR PUMP

### Lubrication

It is not necessary to lubricate the pump or its motor. The motor bearings are lubricated for life. The mechanical shaft seal in the pump is water lubricated and self-adjusting.

### Draining for Winter

When the pump is to be disconnected from service, or is in danger of freezing, it must be drained. The pump has a draincock which must be opened. Remove the priming plug to vent the pump. Drain the pressure tank. Drain all piping to a point below the freezing line.

To drain an air volume control (AVC), remove the tubing. Turn the AVC upside down. This will permit any water to drain into tank.

### Disassembly and Assembly of Pump

The Hydroglass® Pump is designed for ease in servicing and maintenance.

1. Disassemble pump as follows:
  - A. Disconnect power.
  - B. Open faucet to relieve pressure.
  - C. Drain pump by opening draincock. Remove pressure switch tubing from fitting on top of pump.
  - D. Remove clamp, Key No. 10, Page 11.
  - E. Remove pump base mounting bolts. Motor assembly and back half assembly of pump can be pulled away from front half.
  - F. Remove O-Rings.
2. Reassembly of pump.
  - A. Clean O-Rings and O-Ring grooves.
  - B. Lubricate O-Rings with petroleum jelly, and place in grooves.
  - C. Slide pump halves together.
  - D. Clean inside of clamp. Place clamp around pump halves. Alternately tighten clamp screw and tap clamp around outside with plastic mallet. This will insure proper seating of O-Ring and clamp.
  - E. Assemble base mounting bolts. Connect pressure switch tubing and close draincock.
  - F. Prime pump and turn on power.

## REMOVING MOTOR FOR SERVICE AND REPLACING SHAFT SEAL

If it is necessary to remove motor, always replace the shaft seal. We suggest you purchase this item, U109-6A, and have it on hand for future use.

**NOTICE:** The seal consists of two parts, a rotating member and a ceramic seat. The surfaces of the seal are easily damaged. Read instructions carefully.

Remove motor as follows:

1. Disassemble pump per instructions above.
2. Remove diffuser and impeller as follows (Key Nos. 7 and 8, Page 11).
  - A. Remove screws holding diffuser.

- B. Loosen two screws and remove motor canopy.
- C. If motor has capacitor, partially unscrew capacitor clamp and move capacitor to one side.

**▲ WARNING** Risk of electrical shock. Do not touch capacitor terminals with body or any metal object.

- D. Hold motor shaft with a 7/16" wrench on the shaft flats.
  - E. Turn impeller counterclockwise when facing it.
3. Remove pump back half from motor by unscrewing four (4) nuts. Pry back half off motor by inserting two (2) screwdrivers between the back pump half and the motor flange. This will force rotating portion of seal off shaft. See Figure 10.

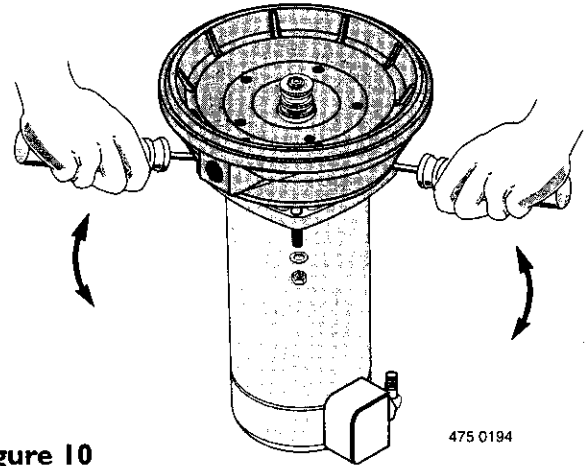

Figure 10

4. Place back half of pump on flat surface and tap out ceramic seat. See Figure 11.

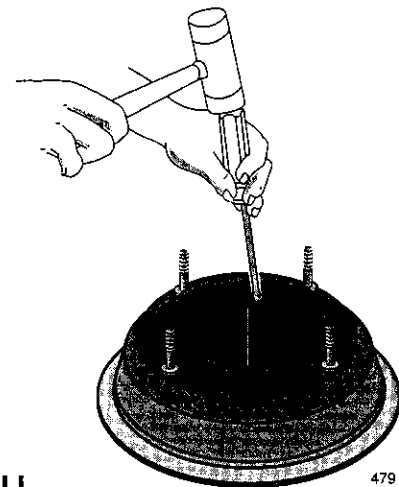

Figure 11

5. Clean seal cavity.
6. Install new seal.
  - A. Clean polished surface of ceramic seat with clean cloth.
  - B. Wet outer edge of O-Ring with detergent solution.



# SERVICE

C. With finger pressure press seat firmly and squarely into cavity. See Figure 12A. Polished face of seat faces inside of pump. If seat will not locate properly, place cardboard washer over polished face and use piece of 3/4" standard pipe for pressing purposes. See Figure 12B.

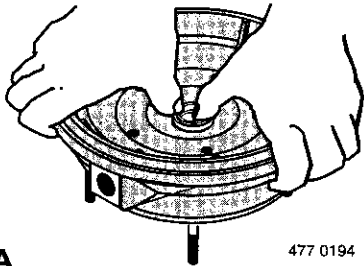

Figure 12A

477 0194

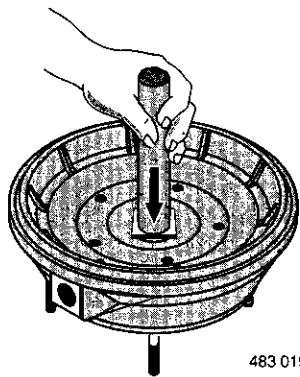

Figure 12B

483 0194

- D. Dispose of cardboard washer and clean surface of seat.
- E. Clean motor shaft.
- F. Reassemble back half of pump to motor.
- G. Apply detergent solution to inside diameter of rotating seal member.
- H. Slide rotating member on shaft until rubber drive ring hits shaft shoulder. **NOTICE: BE SURE** you do not chip or scratch seal face on shaft shoulder or seal will leak!
- I. Screw impeller on shaft (clockwise) while holding shaft with 7/16" open end wrench on shaft flats. This will automatically locate seal in place. See Figure 13.

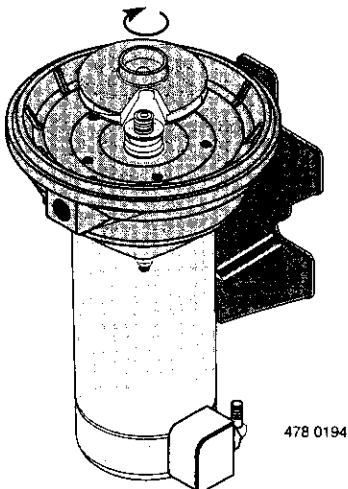

Figure 13

478 0194

- J. Reposition capacitor and replace motor canopy.

K. Remount diffuser on seal plate.

## Cleaning Impeller

1. Follow steps 1A through 1E under "Disassembly and Assembly of Pump" on Page 8.
2. Remove diffuser and impeller from pump per instructions under "Removing Motor for Service and Replacing Shaft Seal" on Page 8.
3. Clean impeller and reassemble impeller and diffuser per instructions under "Removing Motor for Service and Replacing Shaft Seal" on pages 8 and 9.

## Cleaning Shallow Well Jet

To remove debris from venturi or nozzle, proceed as follows:

1. Disassemble pump per instructions on Page 8.
2. Turn venturi counterclockwise and remove it. The nozzle is now exposed. Remove it using a 5/8" hex socket wrench with extension. Turn counterclockwise. If socket wrench is not available, insert an ice pick or similar pointed tool carefully into the nozzle. This will dislodge debris.
3. Flush out the debris by running water through the nozzle in the same direction as the dislodging tool was inserted.
4. Reinstall nozzle and venturi. Do not overtighten!
5. Reassemble pump per instructions on Page 8.

## HELPFUL HINTS

### How to Handle a Gaseous Well

In some areas well water contains gases which must be allowed to escape before the water is used. This can be done as shown in Figure 14.

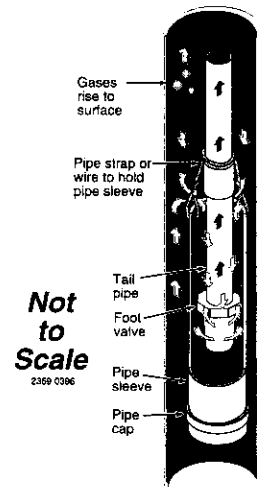

Figure 14

A good way of delivering gas-free water is to suspend a pipe, closed at the bottom and open at the top, surrounding the suction pipe. Since the gases rise in the well casing, the water sucked down through the pipe and into the suction pipe is free of gas. This type of well must be vented to the outside of any enclosure.

### Air Control in Flowing Wells

Flowing wells, or wells with little or no drawdown, could create a special problem in air control in the operation of your water system. In such cases, install a Captive Air® Tank. It does not require any air control.

# REPAIR PARTS

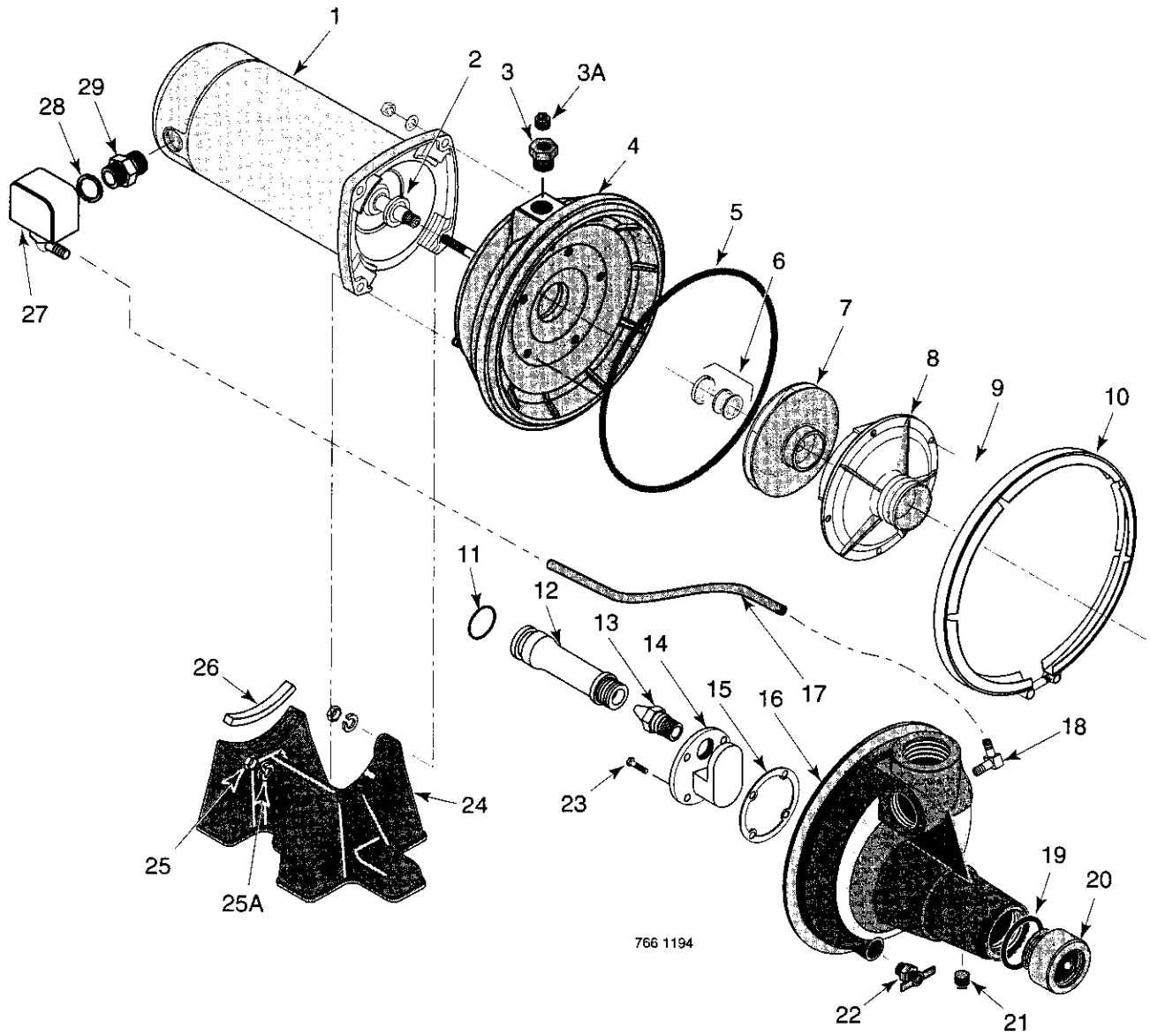

**To Order Parts in the U.S.A., Call  
Sears Product Service, 1-800-366-7278**

**To Order Parts outside the U.S.A., Call  
Your local Sears Service Center or Store**

## REPAIR PARTS

Key No.	1/2 HP Model 390.2514	3/4 HP Model 390.2518	Part Description
1**	J218-953C	–	Motor - 1/2 HP - 115/230V - 60 Cycle
1**	–	J218-954C	Motor - 3/4 HP - 115/230V - 60 Cycle
2	17351-0009	17351-0009	Water Slinger
3*	–	–	Reducer Bushing - 1/2" x 1/8" NPT
3A	WC78-41T	WC78-41T	Pipe Plug - 1/8" NPT
4	L176-47P	L176-47P	Tank Body (Back Half)
5	U9-399	U9-399	O-Ring - (Sq. Cut) Tank Body - 9-1/2" x 9" x 1/4"
6	U109-6A	U109-6A	Shaft Seal
7	J105-40PE	J105-42PT	Impeller
8	J1-39P	J1-39P	Diffuser
9	U30-542SS	U30-542SS	Screw #8 - 32 x 7/8" (5 Required)
•	–	U43-21SS	#8 - Star Washer (5 Required)
10	C19-54SS	C19-54SS	Clamp - Tank Body
11	U9-201	U9-201	O-Ring - Venturi - 1-3/8" x 1-1/8" x 1/8"
12	N32P-66	N32P-66E	Venturi
13	N34P-19	N34P-17	Nozzle
14	N76-29P	N76-29P	Insert
15	J20-18	J20-18	Gasket
16	N176-28PB	N176-28PC	Tank Body Assembly - Front Half Includes Key No. 11, 12, 13, 14, 15, 19, 20 and 23
17	U37-673P	U37-673P	Switch Tube
18	U111-212T	U111-212T	90° Hose Barb
19	U9-226	U9-226	O-Ring - Check Valve - 2-1/4" x 2" x 1/8"
20	N166-5P	N166-5P	Check Valve
21*	–	–	Pipe Plug - 1/8" NPT (2 Required)
22	U212-68T	U212-68T	Draincock - 1/4" NPT
23	U30-742SS	U30-742SS	Screw - #10 - 16 x 1-1/8" (4 Required)
24	C4-42P	C4-42P	Base
25*	–	–	Nut - 5/16" - 18 Hex Head (4 Required)
25A*	–	–	Washer - 5/16" (4 Required)
26	C35-11	C35-11	Motor Pad
27	2782	2782	Pressure Switch
28*	–	–	Locknut - 1/2"
29	L43-5C	L43-5C	Connector

\*Standard hardware item. May be purchased locally.

\*\*For repair or service to motors, always give the motor model number.

• Not illustrated.

# TROUBLESHOOTING CHART

PROBLEM	POSSIBLE CAUSES	REMEDIES
Motor will not run.	<ol style="list-style-type: none"> <li>1. Disconnect switch is off.</li> <li>2. Fuse is blown.</li> <li>3. Starting switch is defective.</li> <li>4. Wires at motor are loose, disconnected, or wired incorrectly.</li> <li>5. Pressure switch contacts are dirty.</li> </ol>	<ol style="list-style-type: none"> <li>1. Be sure switch is on.</li> <li>2. Replace fuse.</li> <li>3. Replace starting switch.</li> <li>4. Refer to instructions on wiring. Check and tighten all wiring.</li> <li>5. Clean by sliding piece of plain paper between contacts.</li> </ol>
Motor runs hot and overload kicks off.	<ol style="list-style-type: none"> <li>1. Motor is wired incorrectly.</li> <li>2. Voltage is too low.</li> <li>3. Pump cycles too frequently.</li> </ol>	<ol style="list-style-type: none"> <li>1. Refer to instructions on wiring.</li> <li>2. Check with power company. Install heavier wiring if wire size is too small. See wiring instructions.</li> <li>3. See section below on too frequent cycling.</li> </ol>
Motor runs but no water is delivered.	<ol style="list-style-type: none"> <li>1. Pump in a new installation did not pick up prime through:               <ol style="list-style-type: none"> <li>a. Improper priming.</li> <li>b. Air leaks.</li> <li>c. Leaking foot valve.</li> </ol> </li> <li>2. Pump has lost its prime through:               <ol style="list-style-type: none"> <li>a. Air leaks.</li> <li>b. Water level below suction of pump.</li> </ol> </li> <li>3. Jet or impeller is plugged.</li> <li>4. Check valve or foot valve is stuck in closed position.</li> <li>5. Pipes are frozen.</li> <li>6. Foot valve and/or strainer are buried in sand or mud.</li> </ol>	<ol style="list-style-type: none"> <li>1. In new installation:               <ol style="list-style-type: none"> <li>a. Re-prime according to instructions.</li> <li>b. Check all connections on suction line, air volume control, and jet.</li> <li>c. Replace foot valve.</li> </ol> </li> <li>2. In installation already in use:               <ol style="list-style-type: none"> <li>a. Check all connections on suction line, air volume control, jet and shaft seal.</li> <li>b. Lower suction line into water and re-prime. If receding water level in a shallow well operation exceeds suction lift, a deep well pump is needed.</li> </ol> </li> <li>3. Clean jet or impeller according to instructions.</li> <li>4. Replace check valve or foot valve.</li> <li>5. Thaw pipes. Bury pipes below frost line. Heat pit or pump house.</li> <li>6. Raise foot valve and/or strainer above well bottom.</li> </ol>
Pump does not deliver water to full capacity (also check point 3 immediately above).	<ol style="list-style-type: none"> <li>1. Water level in well is lower than estimated.</li> <li>2. Steel piping (if used) is corroded or limed, causing excess friction.</li> <li>3. Offset piping is too small in size.</li> </ol>	<ol style="list-style-type: none"> <li>1. A deep well jet pump may be needed (over 20 ft. to water).</li> <li>2. Replace with plastic pipe where possible, otherwise with new steel pipe.</li> <li>3. Use larger offset piping.</li> </ol>
Pump pumps water but does not shut off.	<ol style="list-style-type: none"> <li>1. Pressure switch is out of adjustment or contacts are "frozen".</li> <li>2. Faucets have been left open.</li> <li>3. Jet or impeller is clogged.</li> <li>4. Water level in well is lower than estimated.</li> <li>5. Motor is wired incorrectly.</li> </ol>	<ol style="list-style-type: none"> <li>1. Adjust or replace pressure switch.</li> <li>2. Close faucets.</li> <li>3. Clean jet or impeller.</li> <li>4. Check for possibility of using a deep well jet pump.</li> <li>5. Refer to instructions on wiring.</li> </ol>
Pump cycles too frequently.	<ol style="list-style-type: none"> <li>1. Standard pressure tank is water-logged and has no air cushion.</li> <li>2. Pipes leak.</li> <li>3. Faucets or valves are open.</li> <li>4. Foot valve leaks.</li> <li>5. Pressure switch is out of adjustment.</li> <li>6. Air charge too low in Captive Air® Tank. Model 390.2514 and Model 390.2518 require 40 pounds for proper operation.</li> </ol>	<ol style="list-style-type: none"> <li>1. Drain tank to air volume control tapping. Check air volume control for defects. Check for air leaks at any connection.</li> <li>2. Check connections.</li> <li>3. Close faucets or valves.</li> <li>4. Replace foot valve.</li> <li>5. Adjust or replace pressure switch.</li> <li>6. Disconnect electrical power and open faucets until all pressure is relieved. Using automobile tire pressure gauge, check air pressure in tank at the valve stem located at top of tank. If air pressure is lower, pump air into tank from outside source, until proper air pressure is reached. Check air valve for leaks, using soapy solution, and replace core if necessary.</li> </ol>
Air spurts from faucets.	<ol style="list-style-type: none"> <li>1. Pump is picking up prime.</li> <li>2. Leak in suction side of pump.</li> <li>3. Well is gaseous.</li> <li>4. Intermittent over-pumping of well.</li> </ol>	<ol style="list-style-type: none"> <li>1. As soon as pump picks up prime, all air will be ejected.</li> <li>2. Check suction piping.</li> <li>3. Change installation as described in manual.</li> <li>4. Lower foot valve if possible, otherwise restrict discharge side of pump.</li> </ol>
Leaks at the metal clamps.	<ol style="list-style-type: none"> <li>1. Loose clamps or O-Ring not sealed.</li> </ol>	<ol style="list-style-type: none"> <li>1. Release all system pressure before working on clamp.</li> <li>2. Check that clamp is tight.</li> <li>3. Tap around clamp with hammer on a wooden block. Retighten clamp screw.</li> <li>4. Check O-Ring for proper seating and/or dirt on O-Ring or seat.</li> </ol>

**▲ WARNING**

Release all pressure in system before working on clamp.







# SEARS

## OWNER'S MANUAL

### MODEL NO.

390.2514

390.2518

The model number of your Shallow Well Jet Pump will be found on the pump body.

When requesting service or ordering parts, always give the following information:

- Product Type
- Model Number
- Part Number
- Part Description

# CRAFTSMAN<sup>®</sup> PROFESSIONAL "HYDROGLASS"<sup>®</sup> SHALLOW WELL JET PUMP

For the repair or replacement parts you need

Call 7 am - 7 pm, 7 days a week

**1-800-366-PART**

(1-800-366-7278)

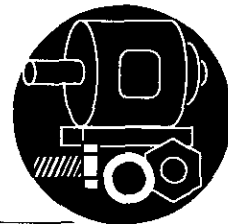

For in-home major brand repair service

Call 24 hours a day, 7 days a week

**1-800-4-REPAIR**

(1-800-473-7247)



For the location of a  
Sears Repair Service Center in your area

Call 24 hours a day, 7 days a week

**1-800-488-1222**



For information on purchasing a Sears  
Maintenance Agreement or to inquire  
about an existing Agreement

call 9 am - 5 pm, Monday-Saturday

**1-800-827-6655**



**SEARS**  
**REPAIR SERVICES**

*America's Repair Specialists*

Sears, Roebuck and Co., Hoffman Estates, IL 60179 U.S.A.