

WEIDER[®] PRO 4900

Model No. 831.154031

Serial No. _____

Write the serial number in the space above for reference.

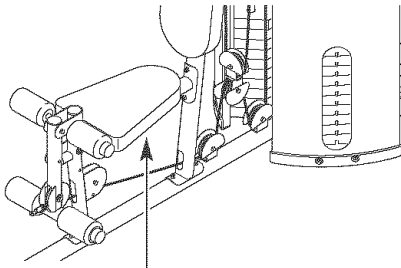

Serial Number Decal (under seat)

WEIGHT SYSTEM EXERCISER User's Manual

- Assembly
- Adjustments
- Troubleshooting
- Part List and Drawing

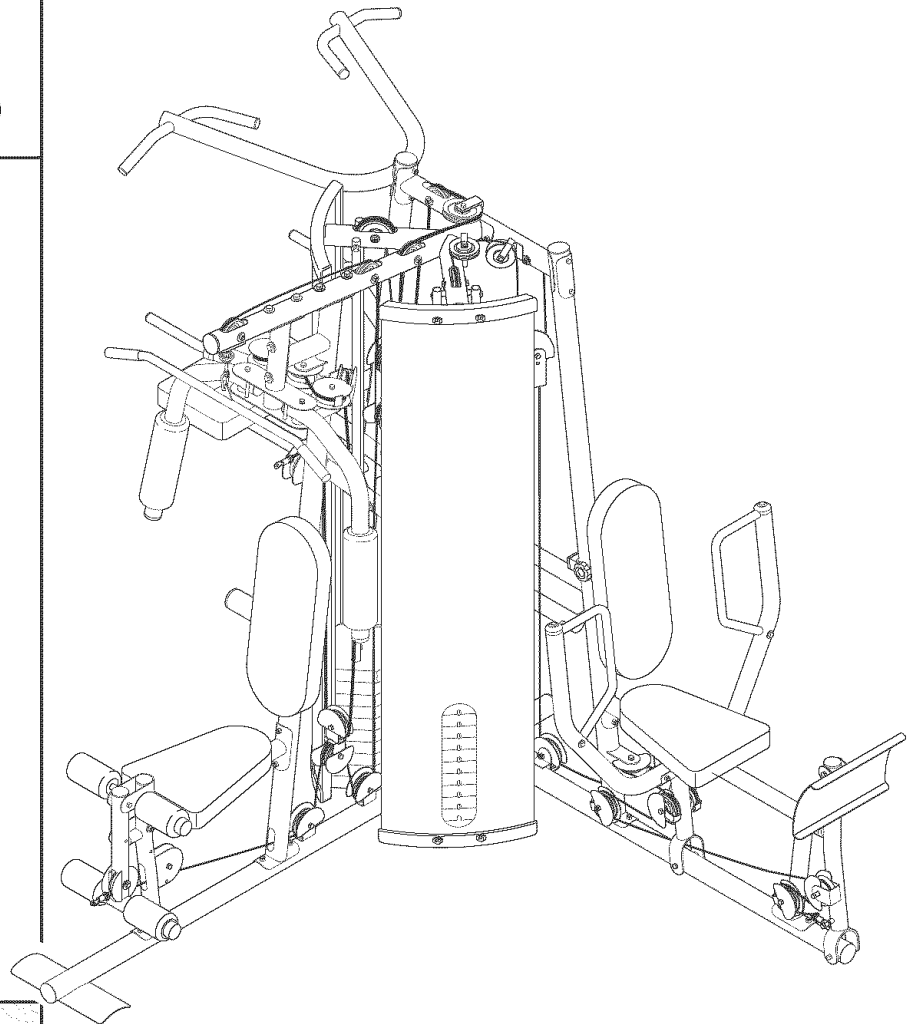

CAUTION

Read all precautions and instructions in this manual before using this equipment. Save this manual for future reference.

Sears, Roebuck and Co., Hoffman Estates, IL 60179

TABLE OF CONTENTS

WARNING DECAL PLACEMENT	2
IMPORTANT PRECAUTIONS	3
BEFORE YOU BEGIN	4
ASSEMBLY	5
ADJUSTMENTS	24
WEIGHT RESISTANCE CHART	26
CABLE DIAGRAM	27
MAINTENANCE	29
EXERCISE GUIDELINES	30
ORDERING REPLACEMENT PARTS	Back Cover
FULL 90-DAY WARRANTY	Back Cover

Note: A PART IDENTIFICATION CHART and a PART LIST/EXPLODED DRAWING are attached in the center of this manual. Remove the PART IDENTIFICATION CHART and PART LIST/EXPLODED DRAWING before beginning assembly.

WARNING DECAL PLACEMENT

The decal shown here has been placed on the weight system. If the decal is missing or illegible, please call toll-free 1-877-992-5999, Monday through Friday, 6 a.m. until 6 p.m. Mountain Time, to order a free replacement decal. Apply the decal in the location shown.

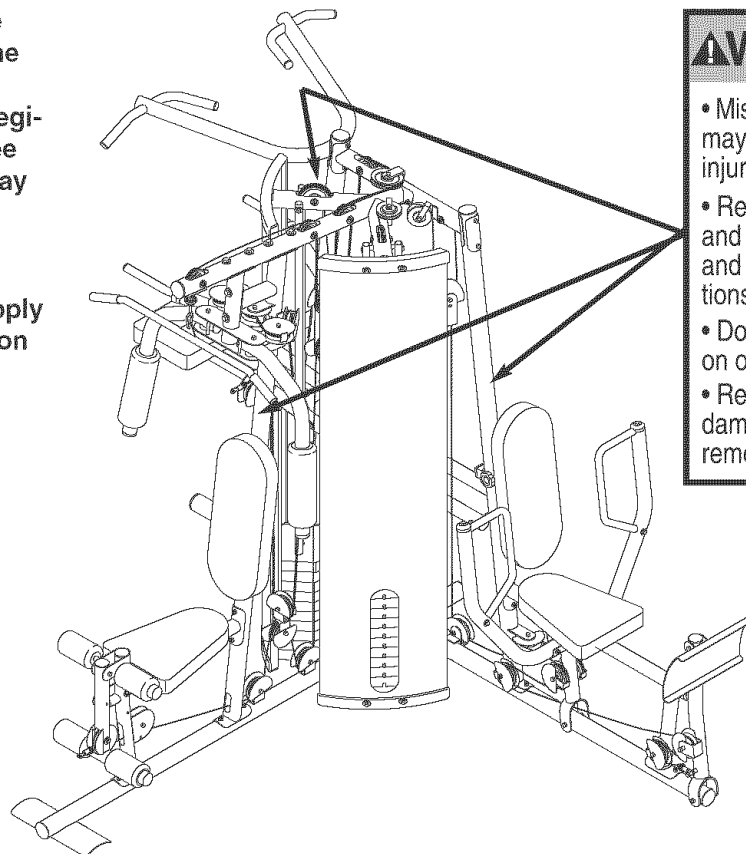

IMPORTANT PRECAUTIONS

⚠ WARNING: To reduce the risk of serious injury, read the following important precautions before using the weight system.

1. Read all instructions in this manual before using the weight system. Use the weight system only as described in this manual.
2. It is the responsibility of the owner to ensure that all users of the weight system are adequately informed of all precautions.
3. The weight system is intended for home use only. Do not use the weight system in any commercial, rental, or institutional setting.
4. Use the weight system only on a level surface. Cover the floor beneath the weight system to protect the floor.
5. Make sure all parts are properly tightened each time the weight system is used. Replace any worn parts immediately.
6. Keep children under 12 and pets away from the weight system at all times.
7. The weight system is designed to support a maximum user weight of 300 pounds.
8. Always wear athletic shoes for foot protection while exercising.
9. Keep hands and feet away from moving parts.
10. Make sure that the cables remain on the pulleys at all times. If the cables bind as you are exercising, stop immediately and make sure that the cables are on the pulleys. Replace all cables at least every two years.
11. Always secure the weight stack with the lock pin and lock after exercising to prevent unauthorized use of the weight system (see **LOCKING THE WEIGHT STACK** on page 25).
12. Always stand on the foot plate when performing an exercise that could cause the weight system to tip.
13. Never release the arms, leg lever, lat bar, leg press, ab strap, or handle while weights are raised. The weights will fall with great force.
14. *Always disconnect the lat bar from the weight system when performing an exercise that does not use the lat bar.*
15. Keep the resistance system indoors, away from moisture and dust. Do not put the resistance system in a garage or covered patio, or near water.
16. If you feel pain or dizziness at any time while exercising, stop immediately and begin cooling down.

⚠ WARNING: Before beginning this or any exercise program, consult your physician. This is especially important for persons over the age of 35 or persons with pre-existing health problems. Read all instructions before using. Sears assumes no responsibility for personal injury or property damage sustained by or through the use of this product.

BEFORE YOU BEGIN

Thank you for selecting the versatile WEIDER® PRO 4900 weight system. The weight system offers an impressive array of weight stations designed to develop every major muscle group of the body. Whether your goal is to tone your body, build dramatic muscle size and strength, or improve your cardiovascular system, the weight system will help you to achieve the specific results you want.

For your benefit, read this manual carefully before using the weight system. If you have questions after

reading this manual, call 1-800-4-MY-HOME® (1-800-469-4663). To help us assist you, please note the product model number and serial number before calling. The model number is 831.154031. The serial number can be found on a decal attached to the weight system (see the front cover of this manual for the location of the decal).

Before reading further, please review the drawing below and familiarize yourself with the parts that are labeled.

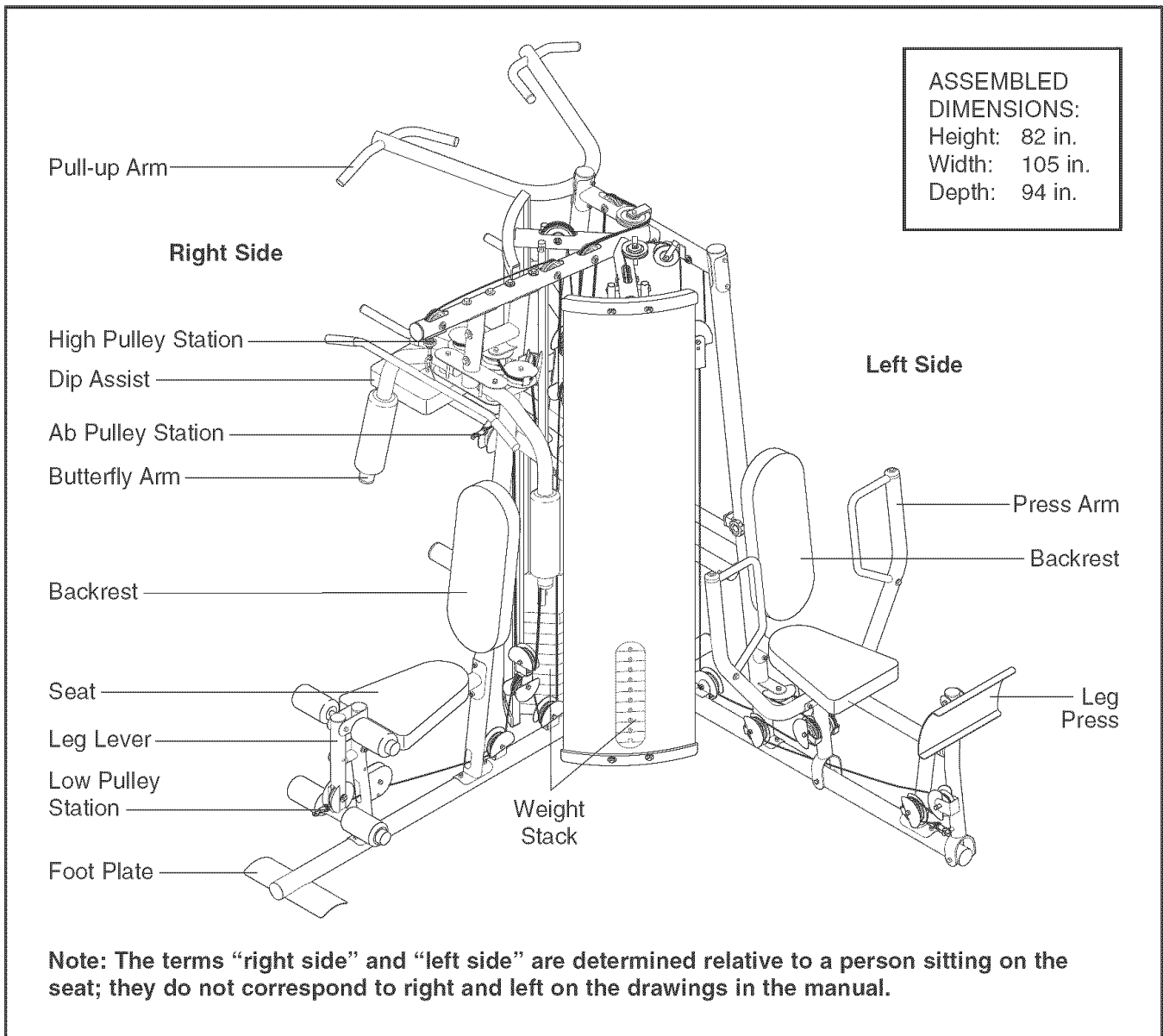

ASSEMBLY

Make Assembly Easier for Yourself

Everything in this manual is designed to ensure that the weight system can be assembled successfully by anyone. **Before beginning assembly, make sure to read the information on this page. This brief introduction will save you much more time than it takes to read it.**

Assembly Requires Two Persons

For your convenience and safety, assemble the weight system with the help of another person.

Set Aside Enough Time

Due to the many features of the weight system, the assembly process will require several hours. By setting aside plenty of time and by deciding to make the task enjoyable, assembly will go smoothly. You may want to assemble the weight system over a couple of evenings.





Select a Location for the Weight System

Because of its weight and size, the weight system should be assembled in the location where it will be used. Make sure that there is enough room to walk around the weight system as you assemble it.

How to Unpack the Box

To make assembly as easy as possible, we have divided the assembly process into four stages. The parts needed for each stage are found in individual bags. **Important: Wait until you begin each stage to open the parts bag for that stage.** Place all parts of the weight system in a cleared area and remove the packing materials. Do not dispose of the packing materials until assembly is completed.

Make sure you have the following tools:

- Two adjustable wrenches 
 - One standard screwdriver 
 - One phillips screwdriver 
 - One rubber mallet 
- You will also need grease or petroleum jelly, a small amount of soapy water, and clear tape or masking tape.

Note: Assembly will be more convenient if you have a socket set, a set of open-end or closed-end wrenches, or a set of ratchet wrenches.

How to Identify Parts

To help you identify the small parts used in assembly, we have included a **PART IDENTIFICATION CHART** in the center of this manual. Place the chart on the floor and use it to easily identify parts during each assembly step. **Note: Some small parts may have been pre-attached. If a part is not in the parts bag, check to see if it has been pre-attached.**

How to Orient Parts

As you assemble the weight system, make sure all parts are oriented exactly as shown in the drawings.

Tightening Parts

Tighten all parts as you assemble them, unless instructed to do otherwise.

Questions?

If you have questions after reading the assembly instructions, please call our Customer Service Department at **1-800-4-MY-HOME® (1-800-469-4663)**.

The Four Stages of the Assembly Process

Frame Assembly—You will begin by assembling the base and the uprights that form the skeleton of the weight system.

Arm Assembly—During this stage you will assemble the arms and the leg lever.

Cable Assembly—During this stage you will attach the cables and pulleys that connect the arms to the weights.

Seat Assembly—During the final stage you will assemble the seats and the backrests.

Frame Assembly

1. Before beginning assembly, make sure you understand the information in the box on page 5. Refer to the **PART IDENTIFICATION CHART** in the center of this manual for help identifying small parts.

Insert four M8 x 75mm Carriage Bolts (84) up through the Right Base (1). **Note: It may be helpful to place a piece of tape over the bolt heads to hold them in place.**

2. Insert four M8 x 75mm Carriage Bolts (84) up through the Left Base (2). **Note: It may be helpful to place a piece of tape over the bolt heads to hold them in place.**

3. Insert two M8 x 75mm Carriage Bolts (84) up through the Rear Base (3). **Note: It may be helpful to place a piece of tape over the bolt heads to hold them in place.**

4. Attach the Rear Base (3) and the Left Base (2) to the Right Base (1) with two M8 x 83mm Bolts (89) and two M8 Nylon Locknuts (115). **Do not tighten the Locknuts yet.**

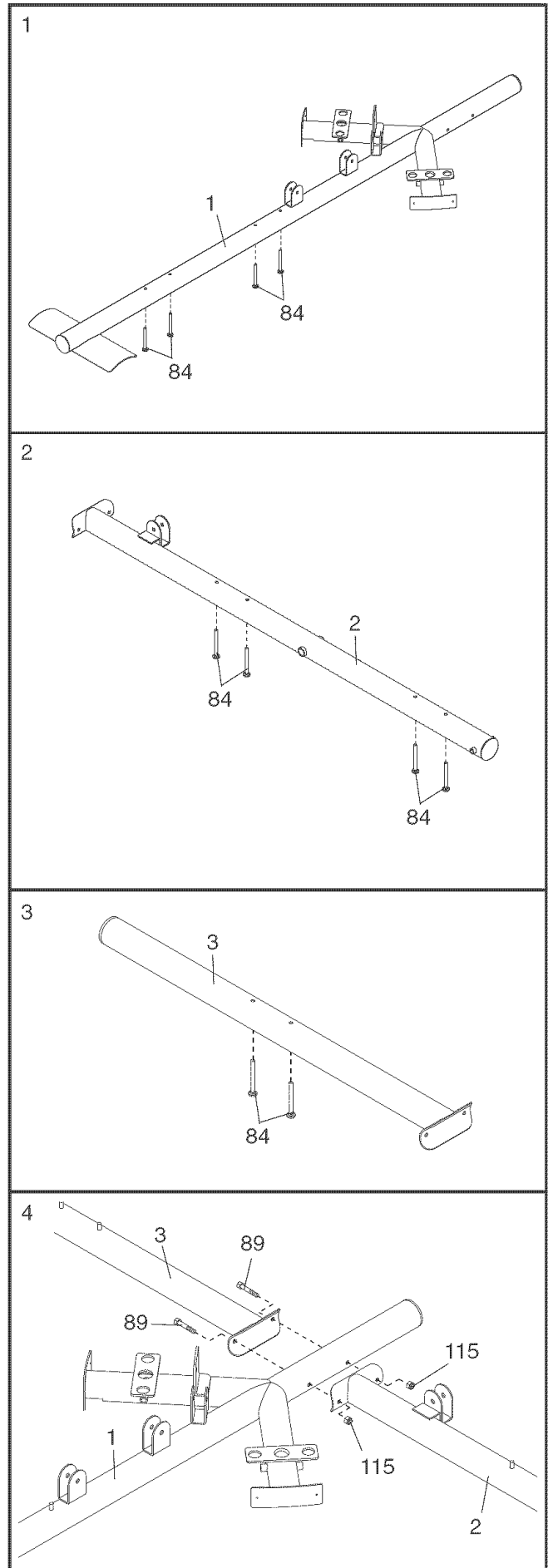

5. Attach the Rear Upright (6) to the Rear Base (3) with the two indicated M8 x 75mm Carriage Bolts (84) and two M8 Nylon Locknuts (115). **Do not tighten the Locknuts yet.**

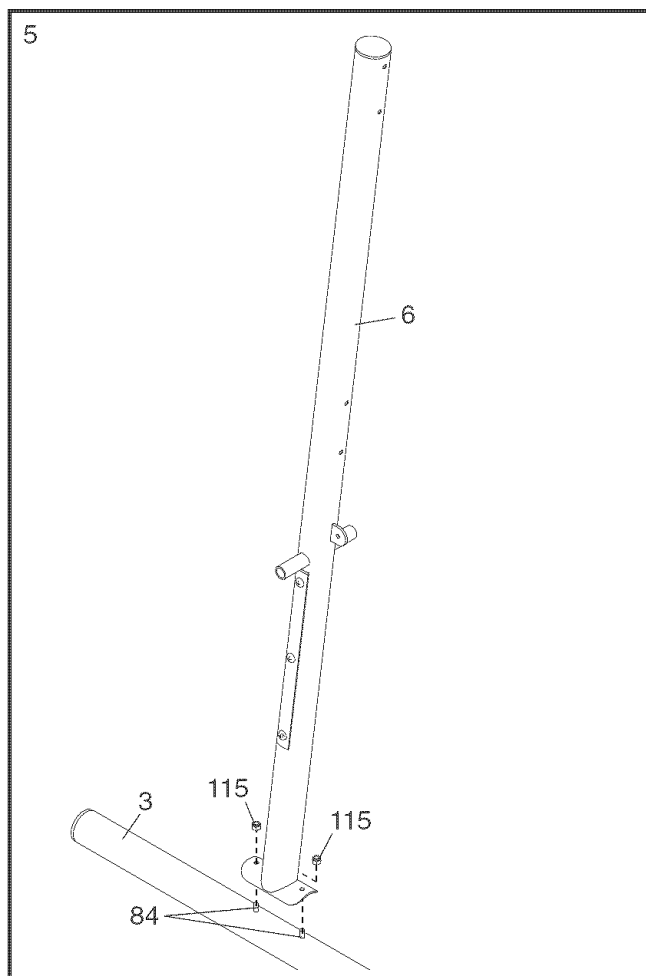

6. Attach the Right Upright (4) to the Right Base (1) with the two indicated M8 x 75mm Carriage Bolts (84) and two M8 Nylon Locknuts (115). **Do not tighten the Locknuts yet.**

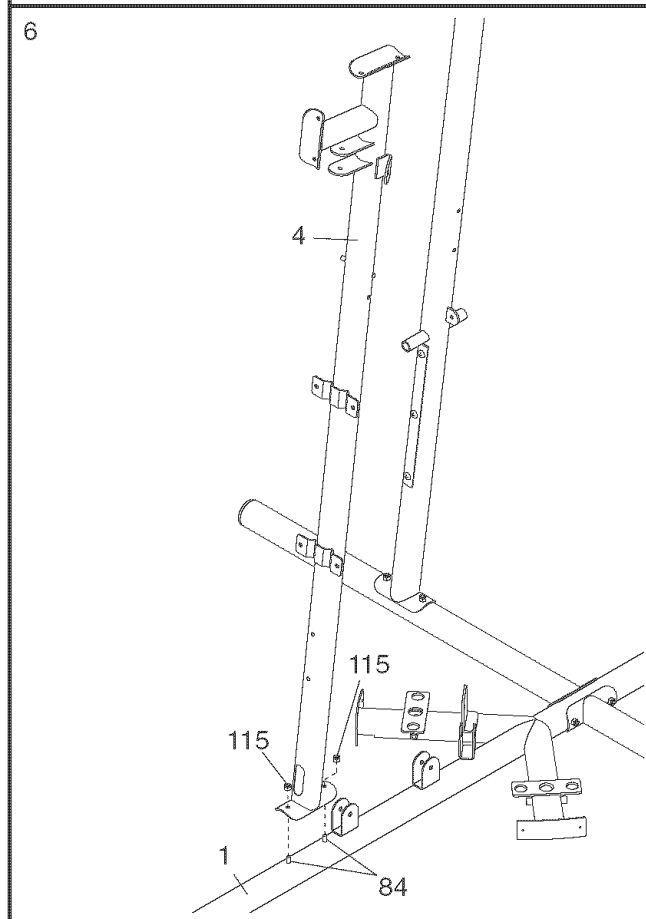

- Attach the Left Upright (5) to the Left Base (2) with the two indicated M8 x 75mm Carriage Bolts (84) and two M8 Nylon Locknuts (115). **Do not tighten the Locknuts yet.**

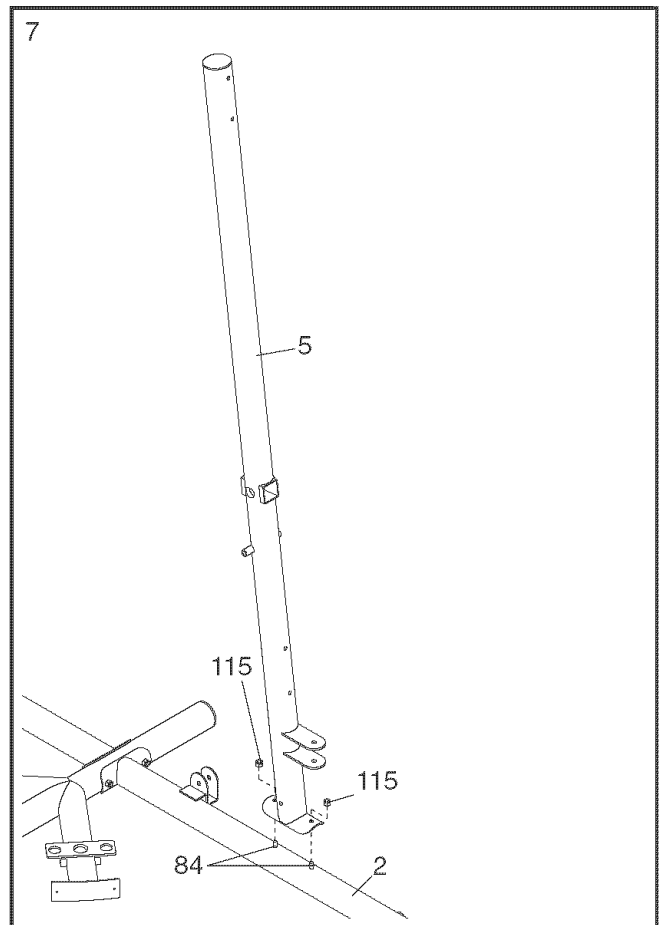

- Hold the Left Top Frame (8) between the Left Upright (5) and the Rear Upright (6). Attach the Pull-up Arm (19) and the Left Top Frame to the Rear Upright with two M8 x 83mm Bolts (89), two M8 Washers (117), and two M8 Nylon Locknuts (115). **Make sure the indicated handles point up. Do not tighten the Locknuts yet.**

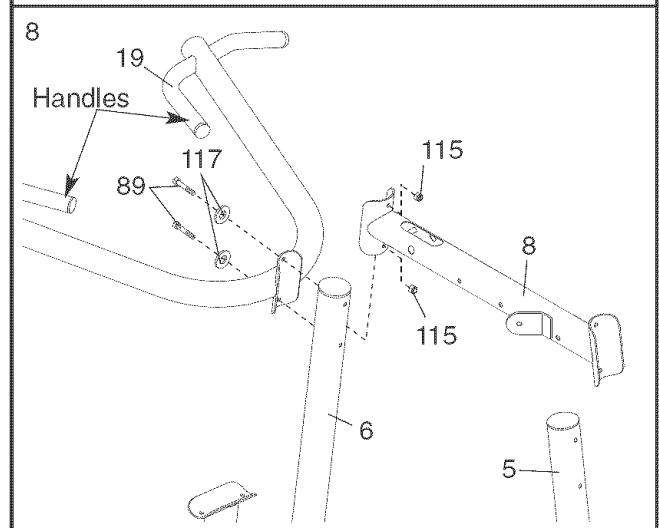

- Attach the Left Top Frame (8) to the Left Upright (5) with two M8 x 83mm Bolts (89), the Left Upright Plate (37), and two M8 Nylon Locknuts (115). **Note: The Left Upright Plate is wider than the Rear Plate (not shown). Do not tighten the Locknuts yet.**

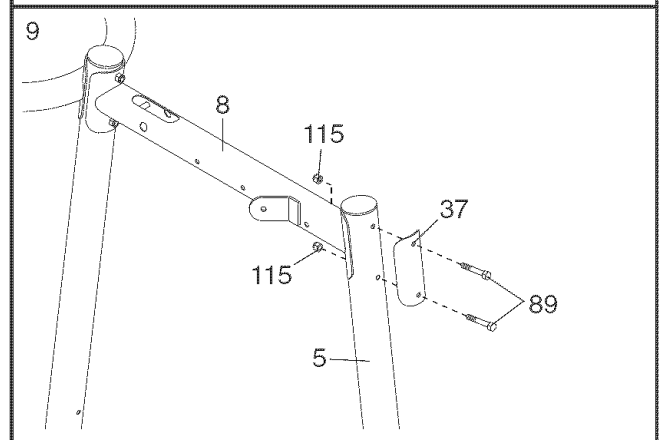

10. Identify the Front Weight Guides (136), which have the lock holes closer to the center than the Rear Weight Guides (24). Orient the Weight Guides with the holes closer to the bottom.

Attach the Front Weight Guides (136) to the Right Base (1) with an M10 x 155mm Bolt (130), two M10 Washers (116), and an M10 Nylon Locknut (114).

Slide two Weight Bumpers (65) onto the Front Weight Guides (136). Slide the ten Weights (35), with the pin holes on the indicated side, onto the Weight Guides.

Press a Weight Tube Bumper (66) into the Long Weight Tube (36). Insert the Weight Tube into the stack of Weights (35). **Make sure the pin on the Weight Tube sits in the groove on the top Weight.**

Grease the indicated holes in a Top Weight (34) with an included grease pack. Slide the Top Weight onto the Front Weight Guides (136).

Repeat this step with the Rear Weight Guides (24) and eight Weights (35).

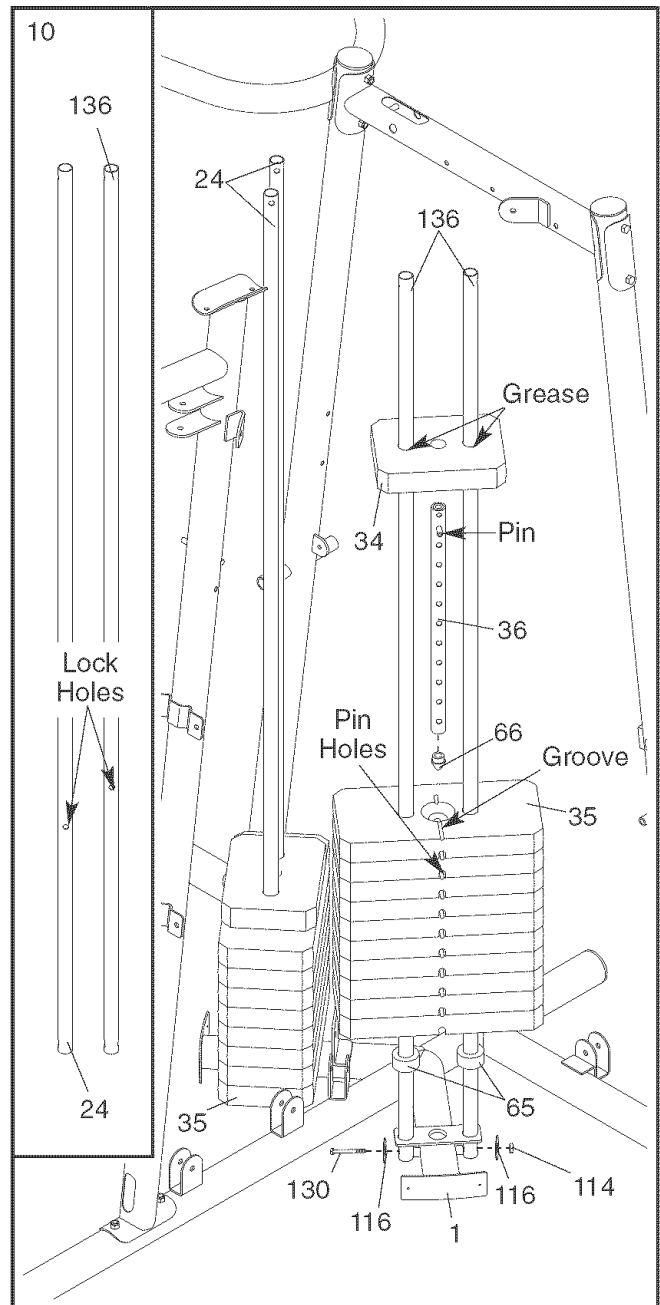

11. Attach the Right Top Frame (7) to the Right Upright (4) with two M8 x 80mm Bolts (94), two M8 Washers (117), and two M8 Nylon Locknuts (115). **Do not tighten the Locknuts yet.**

Attach the Right Top Frame (7) to the Left Top Frame (8) with two M8 x 80mm Bolts (94), two M8 Washers (117), and two M8 Nylon Locknuts (115). **Do not tighten the Locknuts yet.**

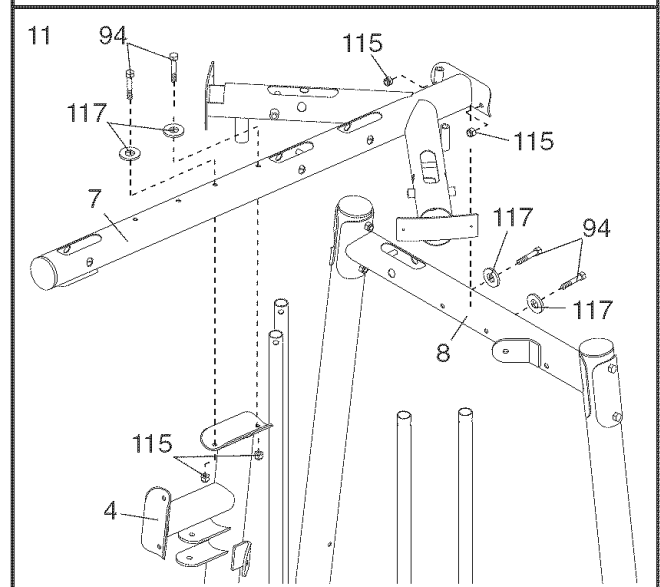

12. Attach the Front Weight Guides (136) to the Right Top Frame (7) with two M10 x 38mm Screws (82) and two M10 Washers (116).

Repeat this step with the Rear Weight Guides (24).

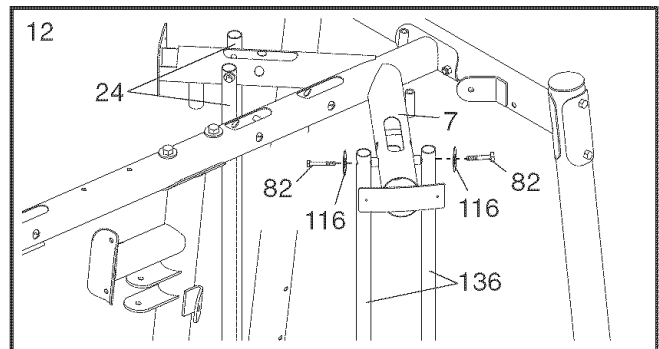

13. Orient the Butterfly Frame (22) as shown. Attach the Butterfly Frame to the Right Upright (4) with two M8 x 72mm Bolts (91), two M8 Washers (117), and two M8 Nylon Locknuts (115). **Do not tighten the Locknuts yet.**

Attach the Butterfly Frame (22) to the Right Top Frame (7) with two M8 x 80mm Bolts (94), two M8 Washers (117), and two M8 Nylon Locknuts (115). **Do not tighten the Locknuts yet.**

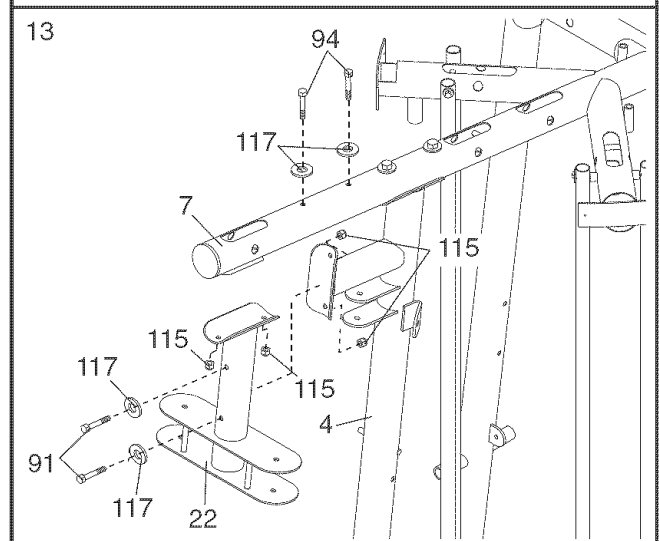

14. Attach the Left Seat Frame (10) to the Left Base (2) with the two indicated M8 x 75mm Carriage Bolts (84) and two M8 Nylon Locknuts (115). **Do not tighten the Locknuts yet.**

Attach the Left Seat Frame (10) to the Left Upright (5) with two M8 x 80mm Bolts (94), two M8 Washers (117), and two M8 Nylon Locknuts (115). **Do not tighten the Locknuts yet.**

Attach the Right Seat Frame (9) to the Right Base (1) and the Right Upright (4) in the same manner.

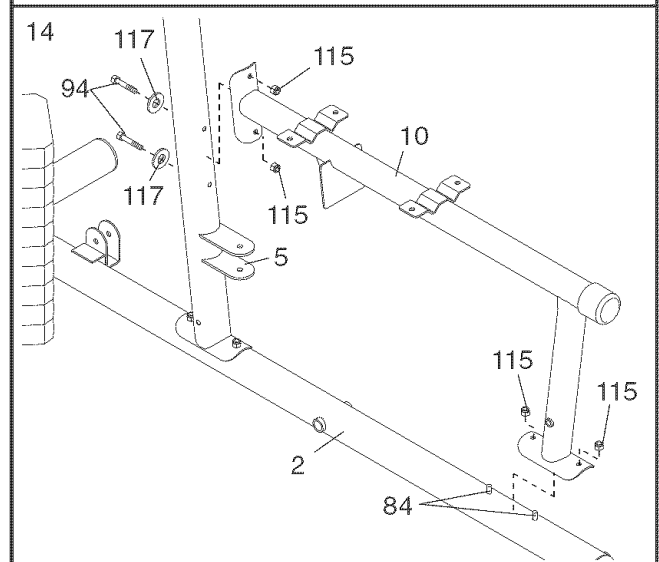

15. Attach the Dip Arm (20) to the Rear Upright (6) with two M8 x 83mm Bolts (89), two M8 Washers (117), the Rear Upright Plate (38), and two M8 Nylon Locknuts (115). **Make sure the indicated handle is horizontal.**

Tighten the M8 Nylon Locknuts (115) used in steps 4–15.

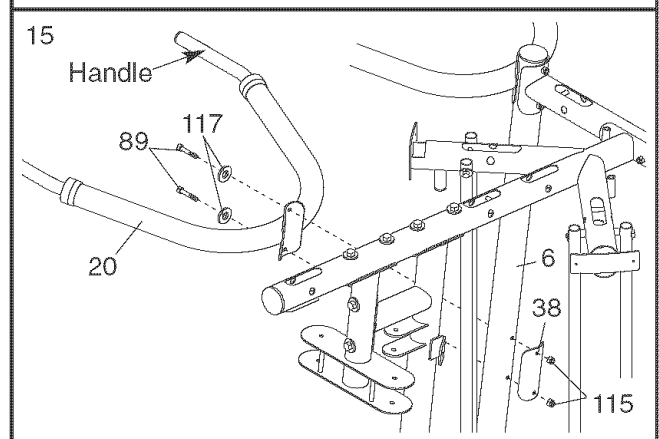

Arm Assembly

16. Grease an M10 x 108mm Bolt (99). Orient the Press Frame (13) as shown. Attach the Press Frame to the Left Base (2) with the Bolt and an M10 Nylon Locknut (114). **Do not overtighten the Locknut; the Press Frame must be able to pivot easily.**

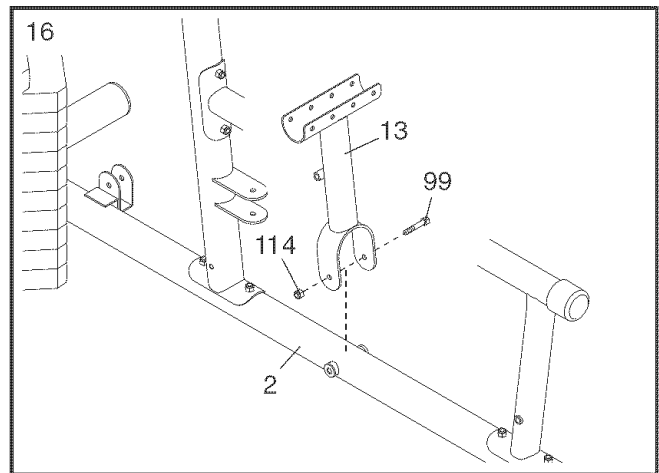

17. Remove the M10 x 45mm Button Bolt (105) from a Press Arm (14).

Attach a Press Handle (16) to a Press Arm (14) with an M10 x 65mm Bolt (96), two M10 Washers (116), two M10 x 12mm Spacers (75), and an M10 Nylon Locknut (114).

Attach a Press Arm Cap (56) to the Press Arm (14) with an M10 x 45mm Button Bolt (105) and an M10 Large Washer (134).

Attach the Press Arm (14) to the Press Frame (13) with two M8 x 70mm Bolts (97) and two M8 Nylon Locknuts (115).

Repeat this step with the other Press Arm (14).

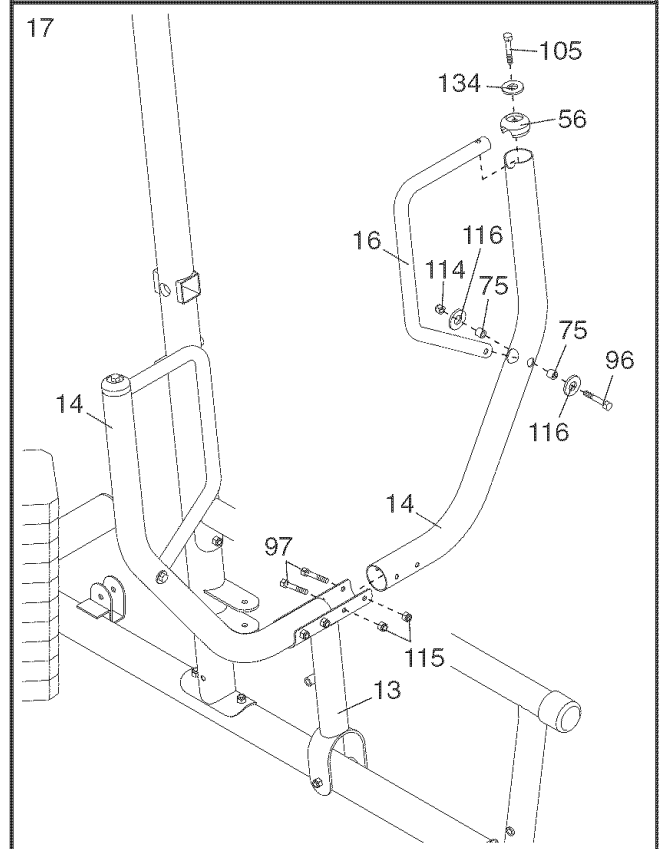

18. Grease an M10 x 108mm Bolt (99). Attach the Leg Press Frame (12) to the Left Base (2) with the Bolt and an M10 Nylon Locknut (114). **Do not overtighten the Locknut; the Leg Press Frame must be able to pivot easily.**

Grease an M10 x 77mm Bolt (133). Attach the Foot Plate (23) to the Leg Press Frame (12) with the Bolt and an M10 Nylon Locknut (114). **Make sure the decal on the Foot Plate is right side up. Do not overtighten the Locknut; the Foot Plate must be able to pivot easily.**

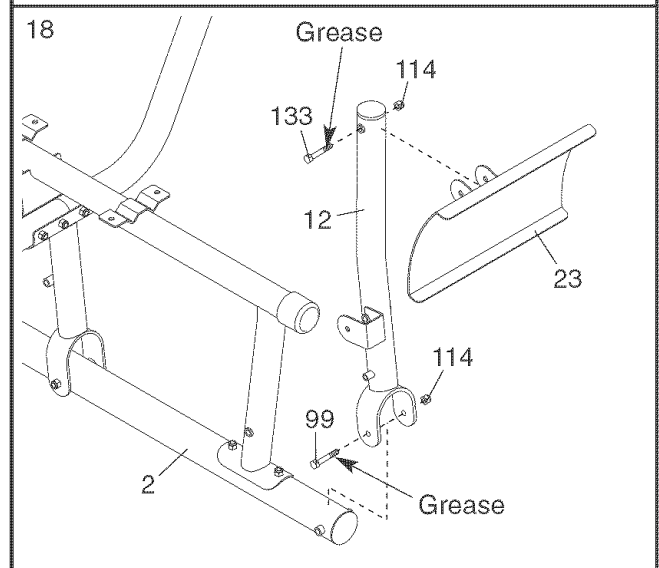

19. Attach the Leg Bumper (76) to the Right Seat Frame (9) with an M4 x 16mm Self-tapping Screw (113) and an M4 Washer (131).

Grease an M10 x 75mm Bolt (104). Attach the Leg Lever (11) to the Right Seat Frame (9) with the Bolt and an M10 Nylon Locknut (114). **Make sure the "U"-rod is on the indicated side of the Leg Lever. Do not over tighten the Locknut; the Leg Lever must be able to pivot easily.**

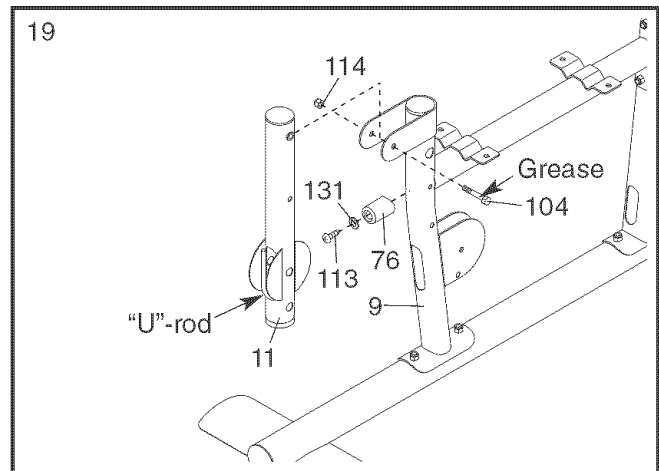

20. Hold the Dip Assist (21) around the Rear Upright (6) and Left Upright (5) as shown. **Make sure the Dip Assist is under the indicated rod.**

Attach the Cross Brace (64) to the Dip Assist (21) with an M10 x 232mm Bolt (108), two M10 Washers (116), and an M10 Nylon Locknut (114).

Grease an M10 x 232mm bolt (108). Attach the Dip Assist (21) to the Left Upright (5) with the Bolt and an M10 Nylon Locknut (114). **Do not over-tighten the Locknut; the Dip Assist must be able to pivot easily.**

Attach the Dip Assist Latch (67) to the Dip Assist (21) with an M10 x 85mm Bolt (107), two M10 Washers (116), a 12mm Spacer (75), and an M10 Nylon Locknut (114). **Do not overtighten the Locknut; the Dip Assist Latch must be able to pivot easily.** Engage the Latch over the rod on the Rear Upright (6).

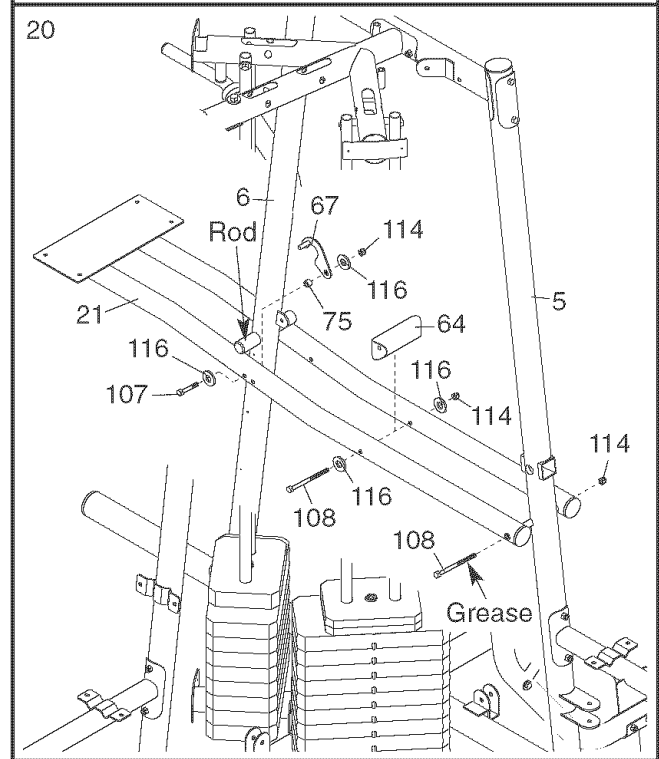

21. Wet the lower end of the Left Butterfly Arm (18) with soapy water. Slide a Large Foam Pad (79) onto the Butterfly Arm.

Note: an entire grease packet should be used for this step. Grease an M10 x 86mm Bolt (92) and the indicated edges of two Arm Bushings (59). Attach the Left Butterfly Arm (18) to the Butterfly Frame (22) with the Bolt, an M10 Large Washer (134), the two Arm Bushings, and an M10 Nylon Locknut (114). **Make sure the bolt head fits inside the hole in the Butterfly Frame.**

Repeat this step with the Right Butterfly Arm (17).

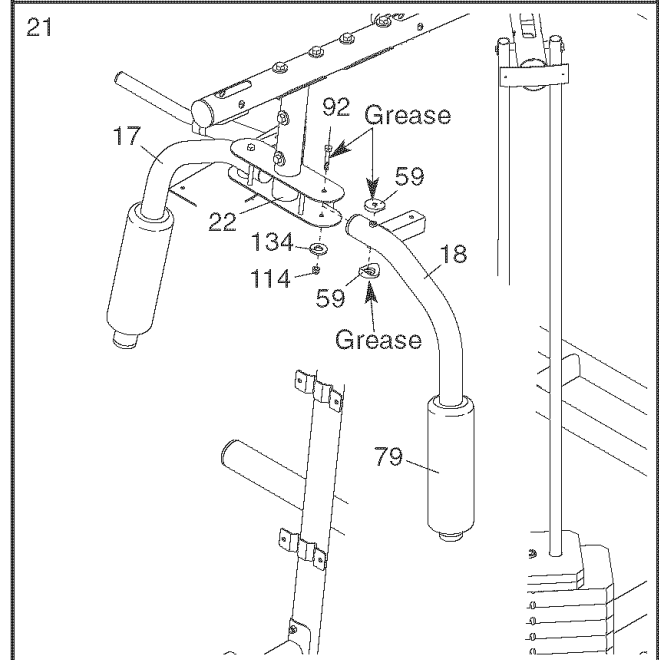

Cable Assembly

22. Refer to the **CABLE DIAGRAMS** on pages 27 and 28 as you assemble the cables and to identify the cables.

Locate the Lat Cable (71). Route the Cable up through the Right Top Frame (7) and over a 90mm Pulley (39). **Make sure the Cable is between the Pulley and the rod in the Top Frame.** Attach the Pulley inside the Top Frame with an M10 x 80mm Bolt (111), two M10 Washers (116), two 19mm Spacers (77), and an M10 Nylon Locknut (114).

23. Route the Lat Cable (71) over a 90mm Pulley (39) and down through the Right Top Frame (7). **Make sure the Cable is between the Pulley and the rod in the Top Frame.** Attach the Pulley inside the Top Frame with an M10 x 80mm Bolt (111), two M10 Washers (116), two 19mm Spacers (77), and an M10 Nylon Locknut (114).

24. Wrap the Lat Cable (71) under a 90mm Pulley (39). Attach the Pulley, a Small Cable Trap (48), and two Half Finger Guards (42) at the second hole from the top of the two Pulley Plates (51) with an M10 x 52mm Bolt (102) and an M10 Nylon Locknut (114). **Make sure the Cable Trap and Finger Guards are oriented as shown.**

25. Route the Lat Cable (71) up through the Right Top Frame (7) and over a 90mm Pulley (39). **Make sure the Cable is between the Pulley and the rod in the Top Frame.** Attach the Pulley inside the Top Frame with an M10 x 80mm Bolt (111), two M10 Washers (116), two 19mm Spacers (77), and an M10 Nylon Locknut (114).

26. Wrap the Lat Cable (71) around a 115mm Pulley (41). Attach the Pulley and a Large Cable Trap (125) to the Right Top Frame (7) with an M10 x 110mm Bolt (73) and an M10 Nylon Locknut (114).

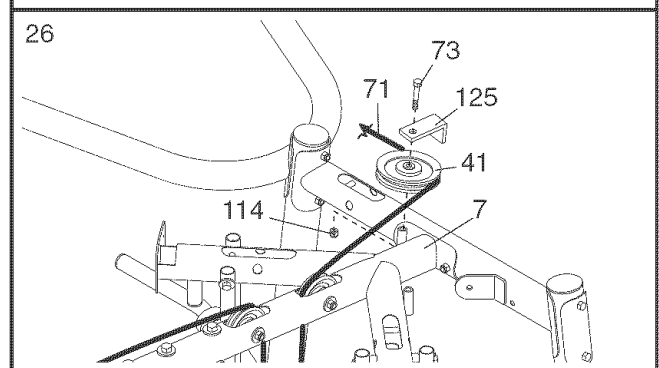
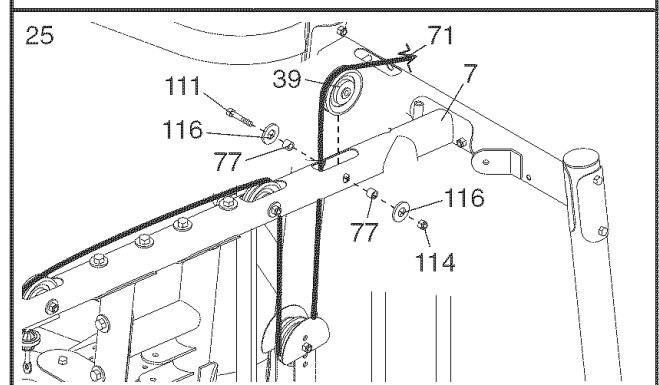
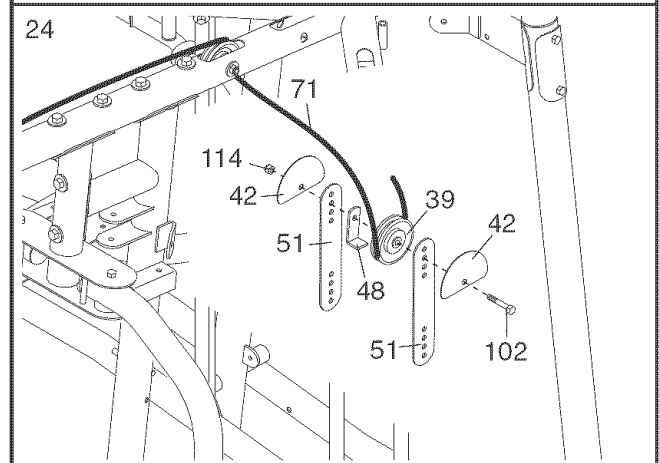
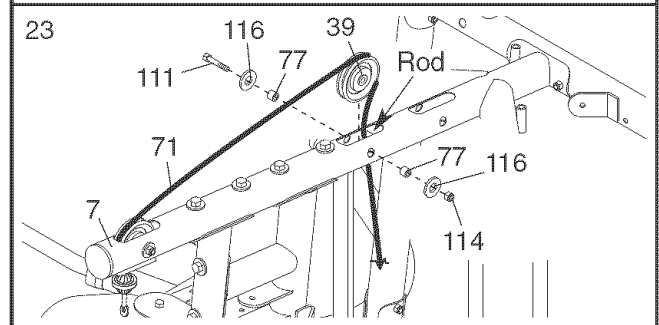
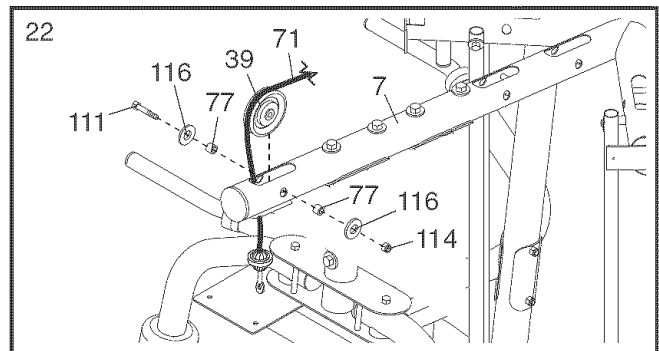

27. Route the Lat Cable (71) over a 90mm Pulley (39) and down through the Left Top Frame (8). Attach the Pulley inside the Top Frame with an M10 x 80mm Bolt (111), two M10 Washers (116), two 19mm Spacers (77), and an M10 Nylon Locknut (114).

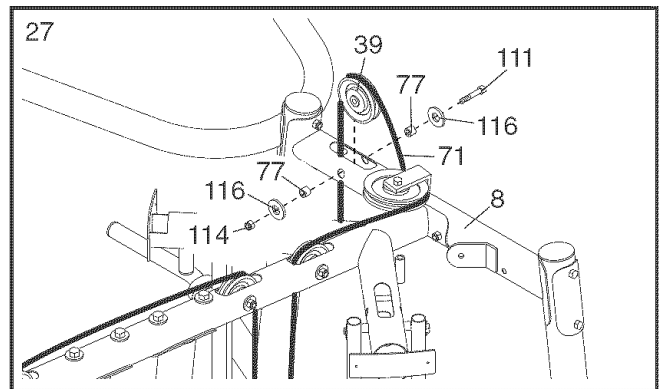

28. Wrap the Lat Cable (71) under a 90mm Pulley (39). Attach the Pulley, a Small Cable Trap (48), and two Full Finger Guards (43) to the Dip Assist (21) with an M10 x 232mm Bolt (108), three M10 Washers (116), two 40mm Spacers (74), and an M10 Nylon Locknut (114). **Make sure the Cable Trap is oriented as shown.**

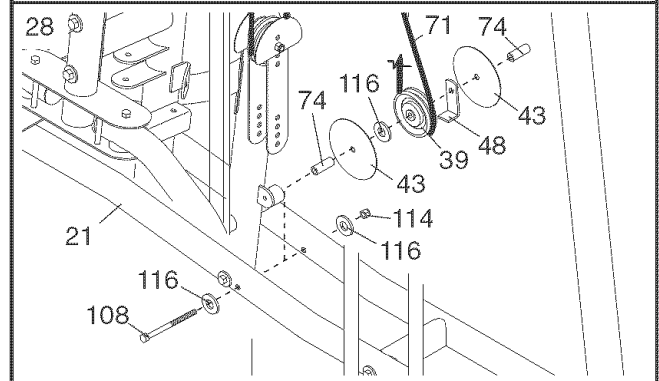

29. Attach the Lat Cable (71) to the bracket on the Rear Upright (6) with an M8 x 22mm Shoulder Bolt (88) and an M8 Nylon Locknut (115). **Make sure the flat edge of the Cable is against the bracket.**

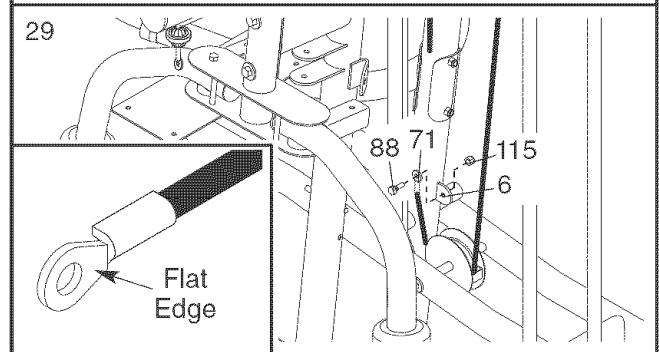

30. **Locate the Ab Cable (72).** Wrap the Cable over a 90mm Pulley (39). Attach the Pulley and the two Quarter Guards (95) to the Right Upright (4) with an M10 x 108mm Bolt (99), an M10 Washer (116), and an M10 Nylon Locknut (114). **Make sure that the rod is inserted through both Quarter Guards and is over the Cable.**

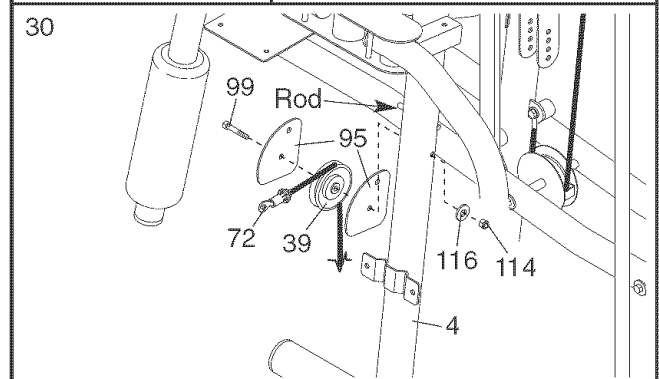

31. Wrap the Ab Cable (72) under a 90mm Pulley (39). Attach the Pulley and two Half Finger Guards (42) to the Double "U"-bracket (52) with an M10 x 48mm Bolt (101) and an M10 Nylon Locknut (114). **Make sure the Finger Guards are oriented as shown.**

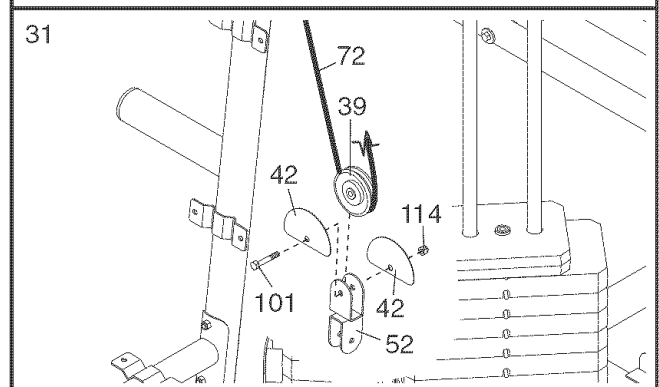

32. Wrap the Ab Cable (72) over a “V”-pulley (40). Attach the “V”-pulley, a Cable Trap (49), an M10 Washer (116), and two Full Finger Guards (43) to the Right Upright (4) with an M10 x 61mm Bolt (90) and an M10 Nylon Locknut (114). **Make sure the Cable Trap is oriented to hold the Cable in the groove of the Pulley.**

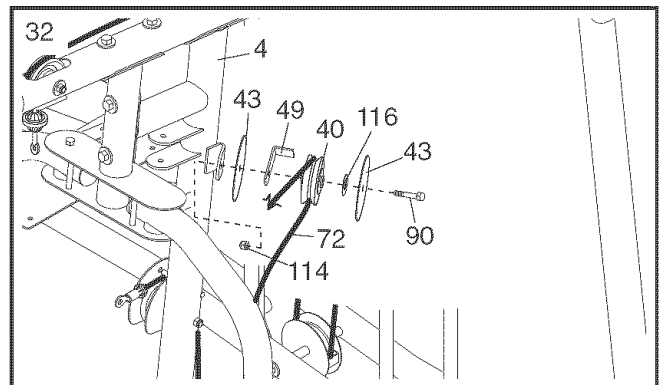

33. Wrap the Ab Cable (72) around a “V”-pulley (40). Attach the “V”-pulley, a Cable Trap (49), an M10 Washer (116), and two Full Finger Guards (43) to the Left Butterfly Arm (18) with an M10 x 61mm Bolt (90) and an M10 Nylon Locknut (114). **Make sure the Cable Trap is oriented to hold the Cable in the groove of the Pulley.**

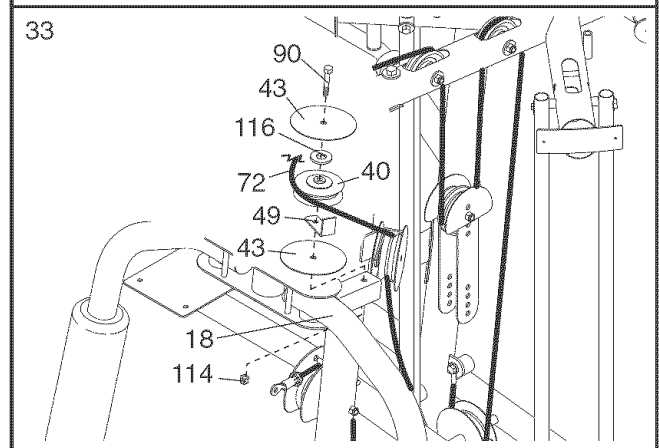

34. Wrap the Ab Cable (72) around a “V”-pulley (40). Attach the “V”-pulley, a Cable Trap (49), an M10 Washer (116), and two Full Finger Guards (43) to the Right Upright (4) with an M10 x 68mm Bolt (93) and an M10 Nylon Locknut (114). **Make sure the Cable Trap is oriented to hold the Cable in the groove of the Pulley.**

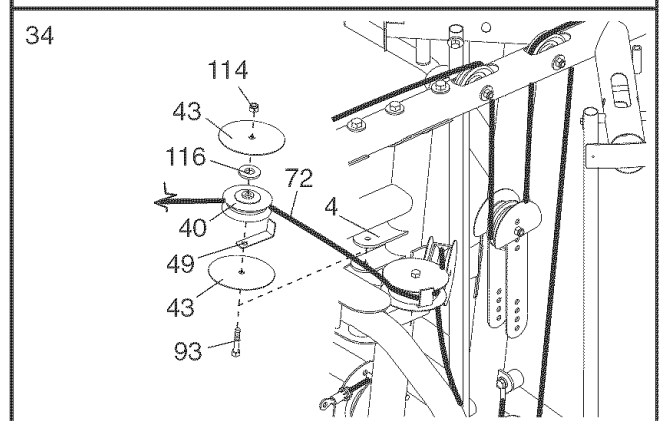

35. Wrap the Ab Cable (72) around a “V”-pulley (40). Attach the “V”-pulley, a Cable Trap (49), an M10 Washer (116), and two Full Finger Guards (43) to the Right Butterfly Arm (17) with an M10 x 61mm Bolt (90) and an M10 Nylon Locknut (114). **Make sure the Cable Trap is oriented to hold the Cable in the groove of the Pulley.**

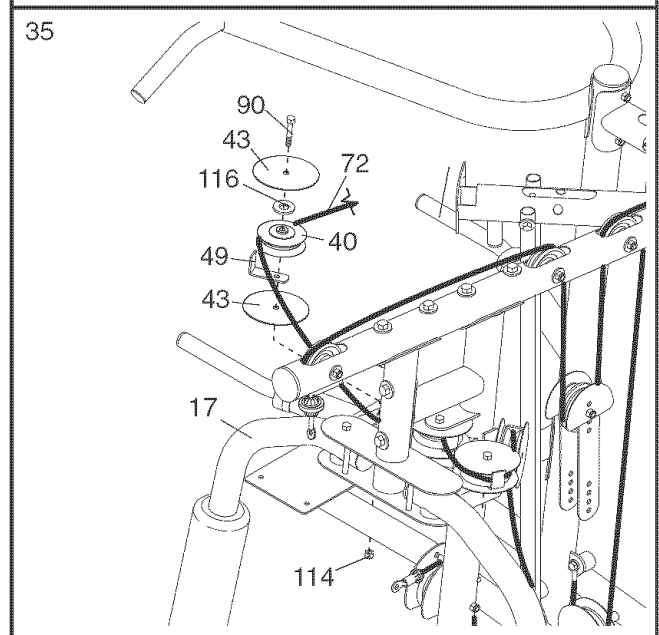

36. Grease an M8 x 22mm Shoulder Bolt (88). Attach the Ab Cable (72) to the bracket on the Right Upright (4) with the Bolt and an M8 Nylon Locknut (115). **Make sure the flat edge of the Cable is against the bracket on the Upright**

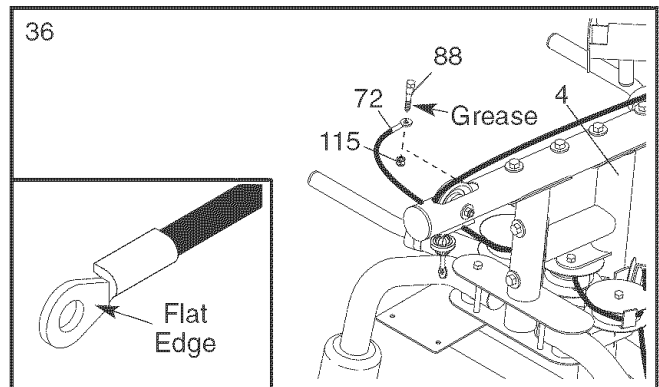

37. **Locate the Leg Lever Cable (70).** Route the Cable through the Leg Lever (11) and the Right Seat Frame (9). Make sure the Cable is over the rod in the Seat Frame.

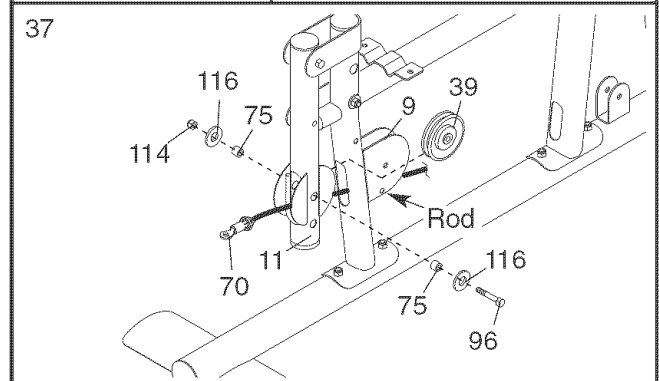

Attach a 90mm Pulley (39) inside the Leg Lever (11), over the Leg Lever Cable (70), with an M10 x 65mm Bolt (96), two M10 Washers (116), two 12mm Spacers (75), and an M10 Nylon Locknut (114).

38. Attach a 90mm Pulley (39) inside the Right Seat Frame (9), over the Leg Lever Cable (70), with an M10 x 45mm Bolt (138) and an M10 Nylon Locknut (114).

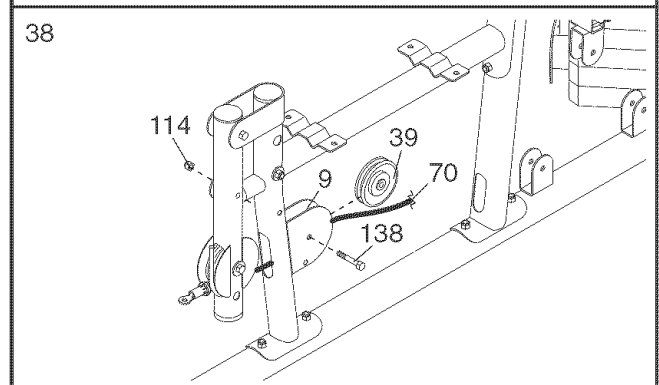

39. Route the Leg Lever Cable (70) through the Right Upright (4) and under a 90mm Pulley (39). Attach the Pulley and two Half Finger Guards (42) to the Right Base (1) with an M10 x 48mm Bolt (101) and an M10 Nylon Locknut (114). **Make sure the Finger Guards are oriented as shown.**

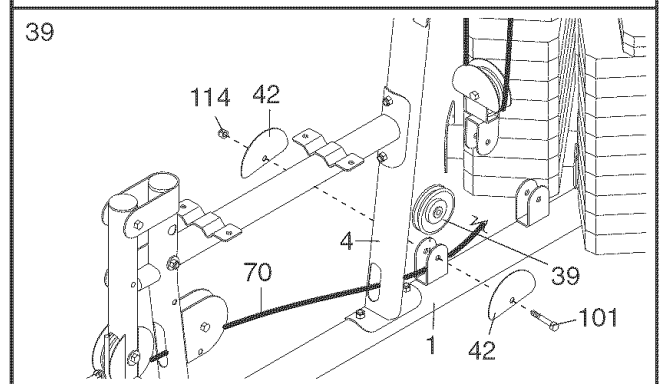

40. Wrap the Leg Lever Cable (70) over a 90mm Pulley (39). Attach the Pulley and two Half Finger Guards (42) to the Double "U"-bracket (52) with an M10 x 48mm Bolt (101) and an M10 Nylon Locknut (114). **Make sure the Finger Guards are oriented as shown.**

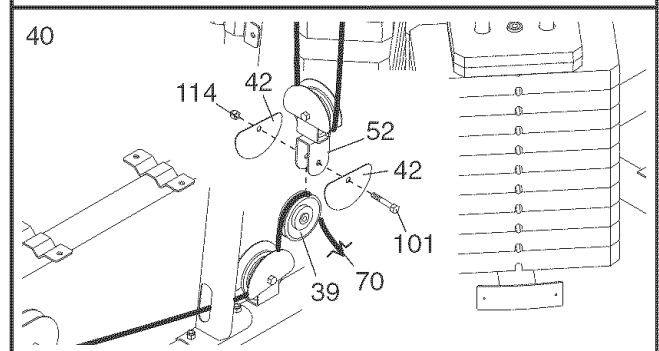

41. Wrap the Leg Lever Cable (70) under a 90mm Pulley (39). Attach the Pulley and two Half Finger Guards (42) to the Right Base (1) with an M10 x 48mm Bolt (101) and an M10 Nylon Locknut (114). **Make sure the Finger Guards are oriented as shown.**

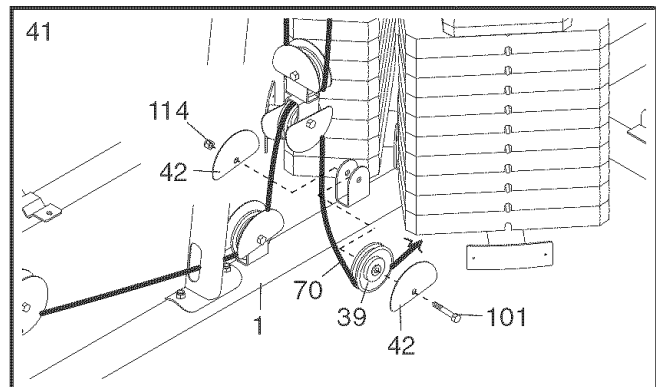

42. Wrap the Leg Lever Cable (70) over a 90mm Pulley (39). Attach the Pulley, a Small Cable Trap (48), and two Half Finger Guards (42) at the second hole from the bottom of the two Pulley Plates (51) with an M10 x 52mm Bolt (102) and an M10 Nylon Locknut (114). **Make sure the Cable Trap and Finger Guards are oriented as shown.**

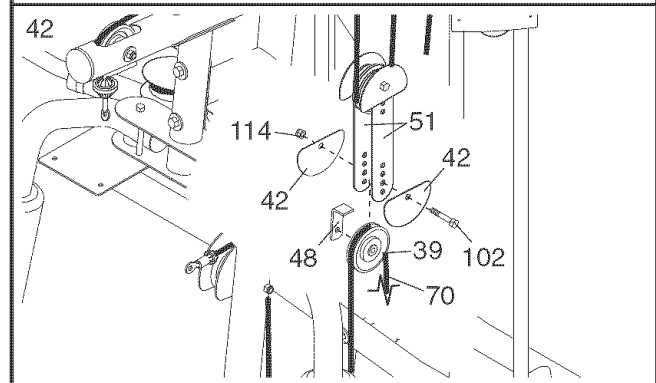

43. Wrap the Leg Lever Cable (70) under a 90mm Pulley (39). Attach the Pulley and two Half Finger Guards (42) to the "U"-bracket on the Right Base (1) with an M10 x 48mm Bolt (101) and an M10 Nylon Locknut (114). **Make sure the Finger Guards are oriented as shown and are on the outside of the "U"-bracket.**

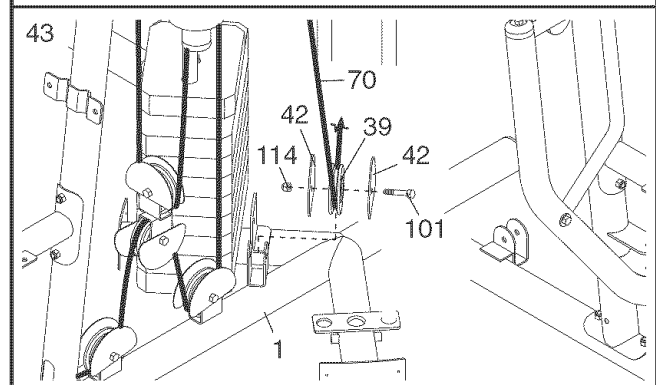

44. Wrap the Leg Lever Cable (70) under a 90mm Pulley (39). Attach the Pulley, a Small Cable Trap (48), and two Half Finger Guards (42) to the bracket on the Right Base (1) with an M10 x 52mm Bolt (102) and an M10 Nylon Locknut (114). **Make sure the Cable Trap and Finger Guards are oriented as shown and that the bracket is between the Pulley and the Finger Guard next to the Locknut.**

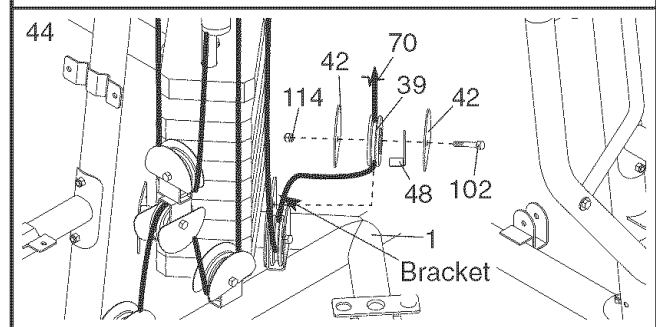

45. Route the Leg Lever Cable (70) up through the Right Top Frame (7), over a 115mm Pulley (41), and back down through the Top Frame. Attach the Pulley inside the Top Frame with an M10 x 80mm Bolt (111), two M10 Washers (116), two 19mm Spacers (77), and an M10 Nylon Locknut (114).

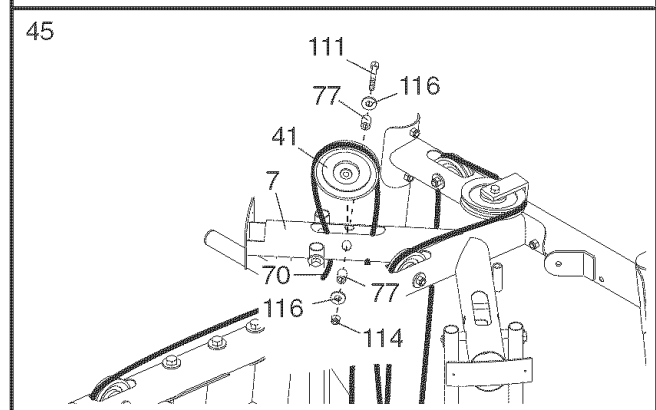

46. Set an M12 Washer (129) on top of the Short Weight Tube (123). Thread an M12 Nut (128) all the way onto the Leg Lever Cable (70).

Thread the Leg Lever Cable (70) into the Short Weight Tube (123). Tighten the M12 Nut (128) against the M12 Washer (129).

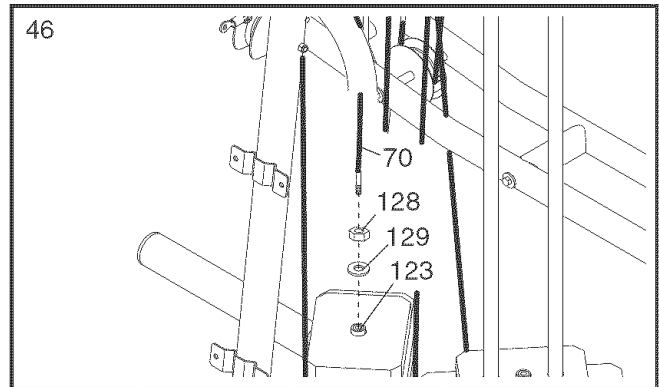

47. **Locate the Right Stack Cable (68).** Attach the Cable to the Left Top Frame (8) with an M8 x 80mm Bolt (94), an M8 Washer (117), and an M8 Nylon Locknut (115).

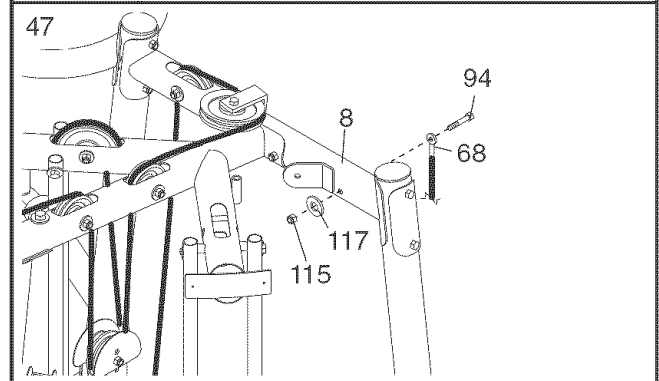

48. Wrap the Right Stack Cable (68) under a 90mm Pulley (39). Attach the Pulley, a Small Cable Trap (48), and two Half Finger Guards (42) to the upper hole in the indicated "U"-bracket (50) with an M10 x 52mm Bolt (102) and an M10 Nylon Locknut (114). **Make sure the Cable Trap and Finger Guards are oriented as shown.**

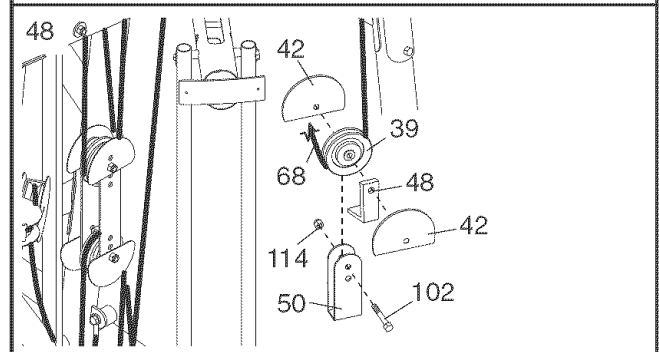

49. Wrap the Right Stack Cable (68) over a "V"-pulley (40). Attach the "V"-pulley and a Cable Trap (49) to the Left Top Frame (8) with an M10 x 55mm Bolt (137) and an M10 Nylon Locknut (114). **Make sure the Cable Trap is oriented to hold the Cable in the groove of the Pulley.**

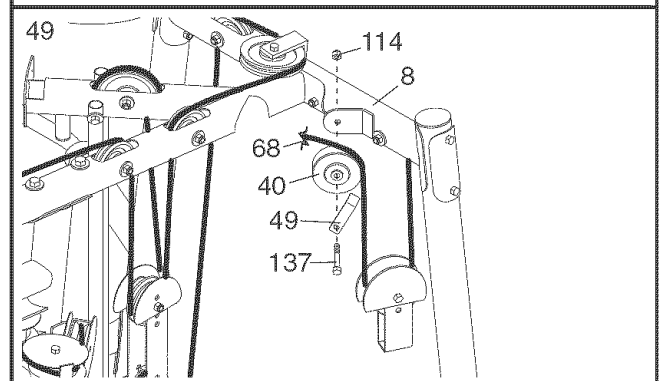

50. Wrap the Right Stack Cable (68) around a 90mm Pulley (39). Attach the Pulley and a Small Cable Trap (48) to the Right Top Frame (7) with an M10 x 110mm Bolt (73) and an M10 Nylon Locknut (114).

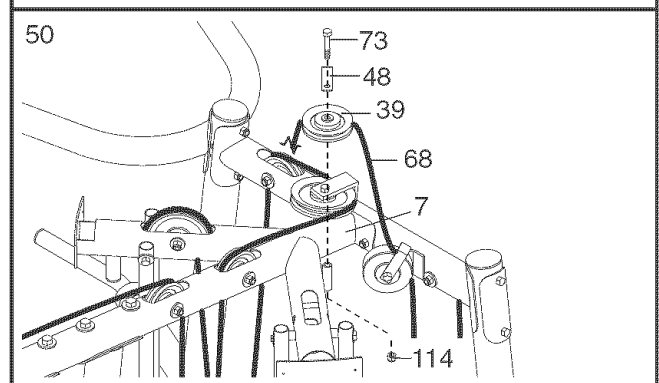

51. Route the Right Stack Cable (70) down through the Right Top Frame (7) and over a 90mm Pulley (39). Attach the Pulley and a Small Cable Trap (48) inside the Top Frame with an M10 x 80mm Bolt (111), two M10 Washers (116), a 19mm Spacer (77), a 16mm Spacer (124), and an M10 Nylon Locknut (114). **Make sure the 16mm Spacer and the Small Cable Trap are on the same side of the Pulley.**

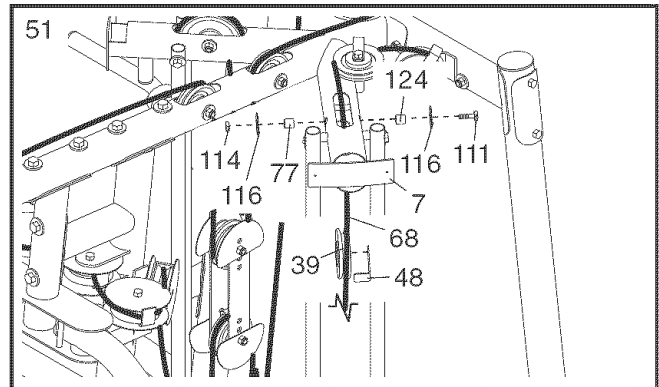

52. Set an M12 Washer (129) on top of the Long Weight Tube (36). Thread an M12 Nut (128) all the way onto the Right Stack Cable (68).

Thread the Right Stack Cable (68) into the Long Weight Tube (36). Tighten the M12 Nut (128) against the M12 Washer (129).

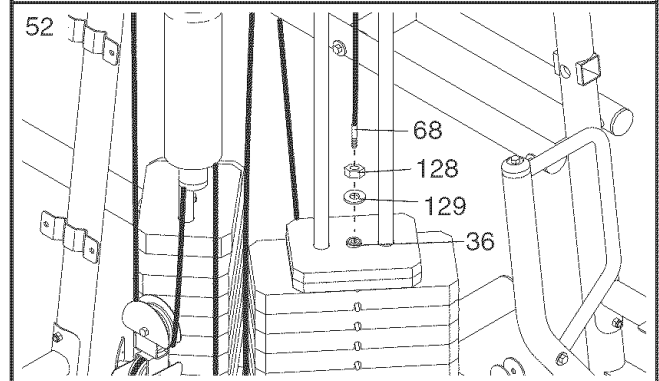

53. **Locate the Press Cable (69).** Grease an M8 x 86mm Shoulder Bolt (86). Attach the Cable to the Leg Press Frame (12) with the Bolt, an M8 Washer (117) and an M8 Nylon Locknut (115).

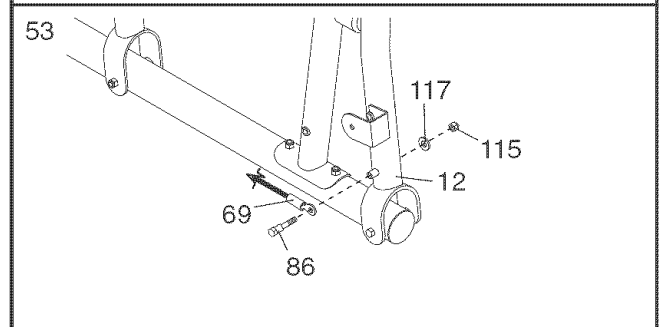

54. Wrap the Press Cable (69) around a 90mm Pulley (39). Attach the Pulley, two Half Finger Guards (42), a Small Cable Trap (48), and an M10 Washer (116) to the Left Seat Frame (10) with an M10 x 103mm Bolt (106), an M10 Washer (116), and an M10 Nylon Locknut (114). **Make sure the Cable Trap and Finger Guards are oriented as shown.**

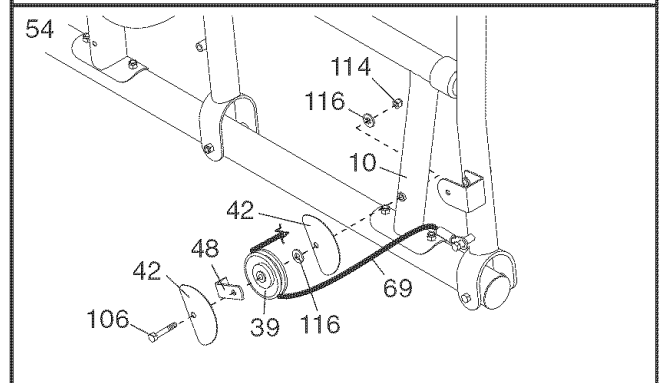

55. Wrap the Press Cable (69) around a "V"-pulley (40). Attach the "V"-pulley, two Half Finger Guards (42), and two M10 Washers (116) to the Leg Press Frame (12) with an M10 x 118mm Bolt (100), an M10 Washer (116), and an M10 Nylon Locknut (114). **Make sure the Finger Guards are oriented as shown.**

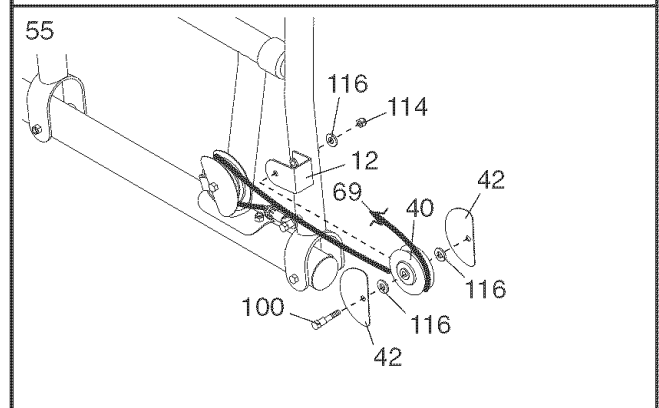

56. Wrap the Press Cable (69) around a 90mm Pulley (39). Attach the Pulley, two Half Finger Guards (42), a Small Cable Trap (48), and an M10 Washer (116) to the Left Upright (5) with an M10 x 108mm Bolt (99), an M10 Washer (116), and an M10 Nylon Locknut (114). **Make sure the Cable Trap and Finger Guards are oriented as shown.**

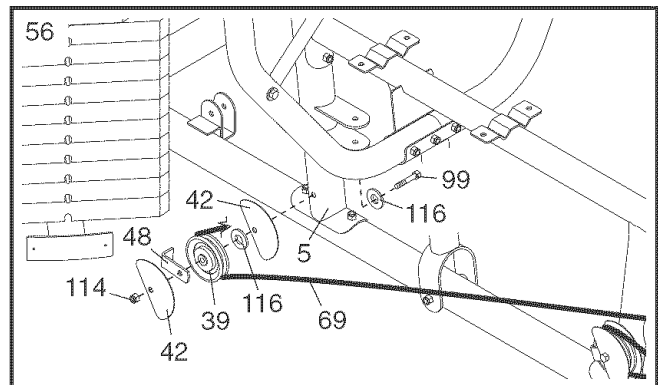

57. Wrap the Press Cable (69) around a 90mm Pulley (39). Attach the Pulley, two Half Finger Guards (42), a Small Cable Trap (48), and an M10 Washer (116) to the Press Frame (13) with an M10 x 135mm Bolt (98). **Make sure the Cable Trap and Finger Guards are oriented as shown.**

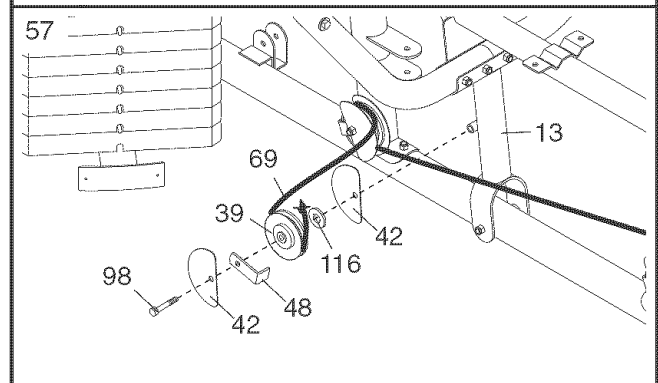

58. Wrap the Press Cable (69) around a "V"-pulley (40). Attach the "V"-pulley, two Half Finger Guards (42), a Cable Trap (49), and an M10 Washer (116) to the Left Upright (5) with an M10 x 68mm Bolt (93) and an M10 Nylon Locknut (114). **Make sure the Cable Trap and Finger Guards are oriented as shown.**

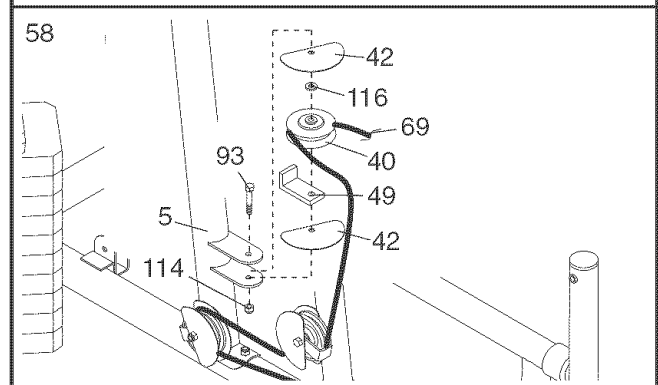

59. Wrap the Press Cable (69) around a 90mm Pulley (39). Attach the Pulley, two Half Finger Guards (42), a Small Cable Trap (48), and an M10 Washer (116) to the Press Frame (13) with the M10 x 135mm Bolt (98) used in step 57 and an M10 Nylon Locknut (114). **Make sure the Cable Trap and Finger Guards are oriented as shown.**

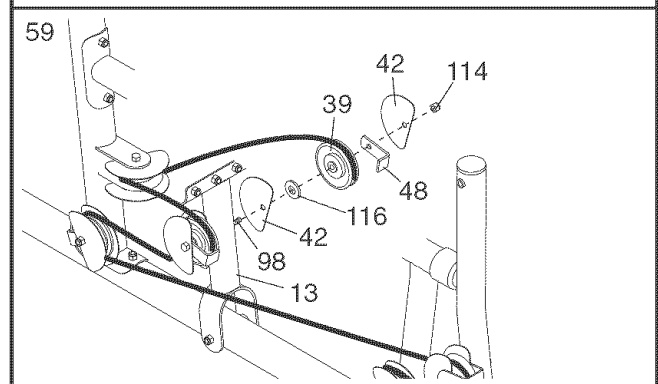

60. Wrap the Press Cable (69) under a 90mm Pulley (39). Attach the Pulley, two M10 Washers (116), and two Half Finger Guards (42) to the Left Base (2) with an M10 x 52mm Bolt (102) and an M10 Nylon Locknut (114). **Make sure the Finger Guards are oriented as shown.**

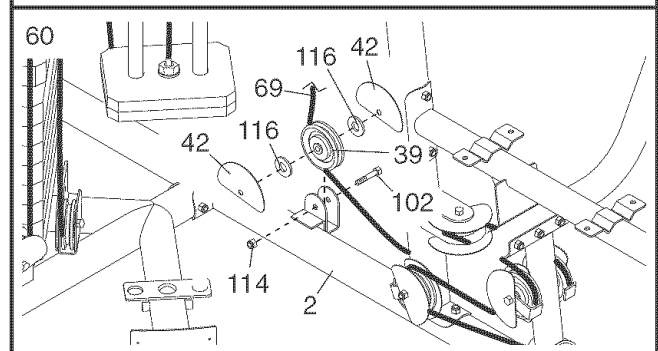

61. Attach the end of the Leg Press Cable (69) to the "U"-bracket (50) with an M8 Washer (117) and an M8 Nylon Locknut (115). **Note: Do not completely tighten the Locknut; it should be tightened so that only two threads of the Cable show past the Locknut, as shown in the inset drawing.**

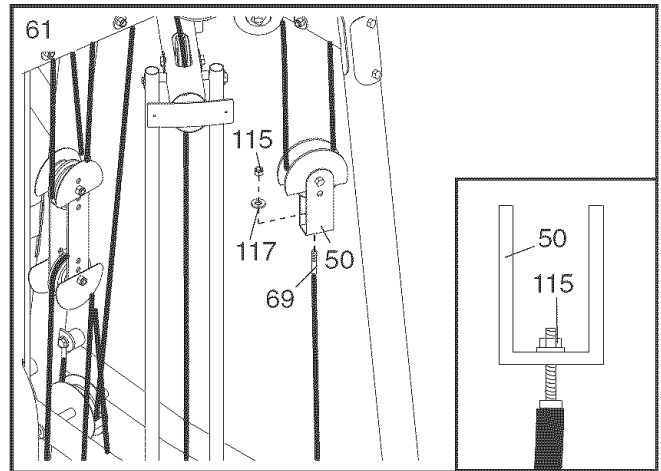

Seat Assembly

62. Attach the Seat (29) with the serial number decal on the bottom to the Right Seat Frame (9) with four M6 x 16mm Screws (85).

Repeat this step with the other Seat (29) and the Left Seat Frame (not shown).

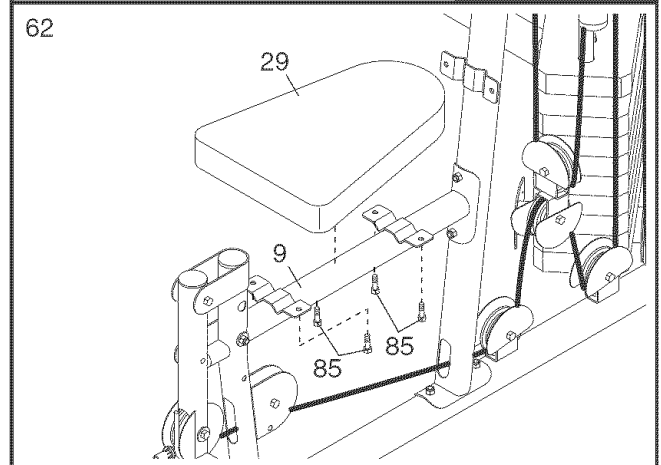

63. Attach the Right Backrest (28) to the Right Upright (4) with four M6 x 16mm Screws (85).

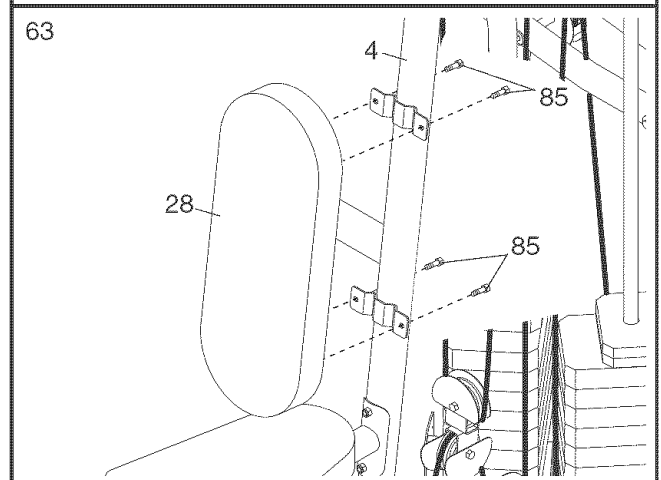

64. Attach the Left Backrest (33) to the Backrest Frame (27) with two M6 x 16mm Screws (85), an M6 x 35mm Screw (139), and an M6 Washer (132).

Slide the Backrest Frame (27) into the Left Upright (5). Engage the Knob (121) into the Upright and Backrest Frame, and turn it clockwise until it is tight.

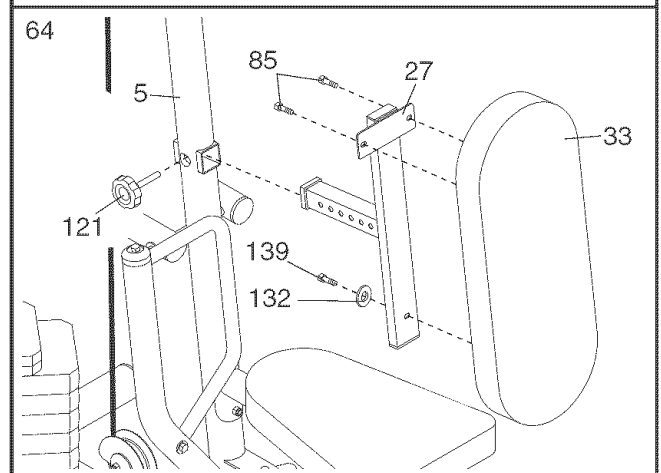

65. Attach the Lock Plate (80) to the Right Seat Frame (9) with an M8 x 69mm Shoulder Bolt (87), an M8 Washer (117), and an M8 Nylon Locknut (115). **Do not overtighten the Locknut; the Lock Plate must be able to pivot easily.**

Attach the Leg Pin (83) to the Right Seat Frame (9) with an M4 x 16mm Self-tapping Screw (113). Insert the Leg Pin through the Lock Plate (80) and the Leg Lever (11).

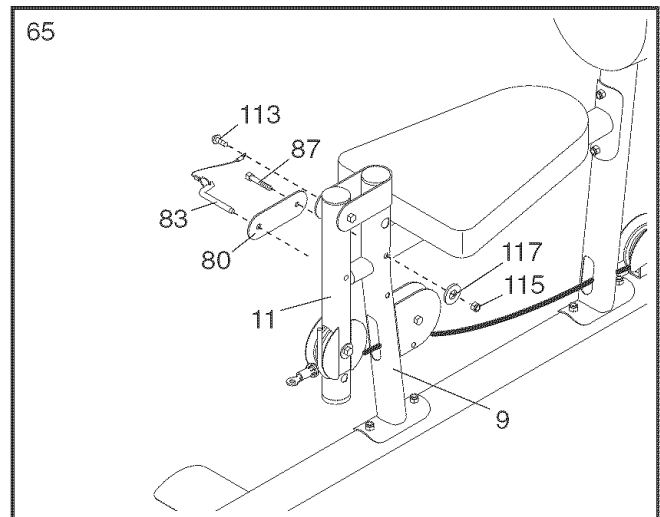

66. Press the two Shroud Covers (26) onto the Front Shroud (15), which has a taller opening than the Rear Shroud (not shown). Attach the Shroud to the Right Top Frame (7) and the Right Base (1) with four M6 x 22mm Bolts (109), four M6 Washers (132), and four M6 Nylon Locknuts (135). **Be careful not to scratch yourself when reaching through the hole in the Shroud.**

Repeat this step with the Rear Shroud (not shown).



67. Slide the Pad Tube (31) through the Right Seat Frame (9). Slide two Small Foam Pads (32) onto the Pad Tube. Press two Foam Caps (58) into the Pad Tubes.

Repeat this step with the Leg Lever (11).

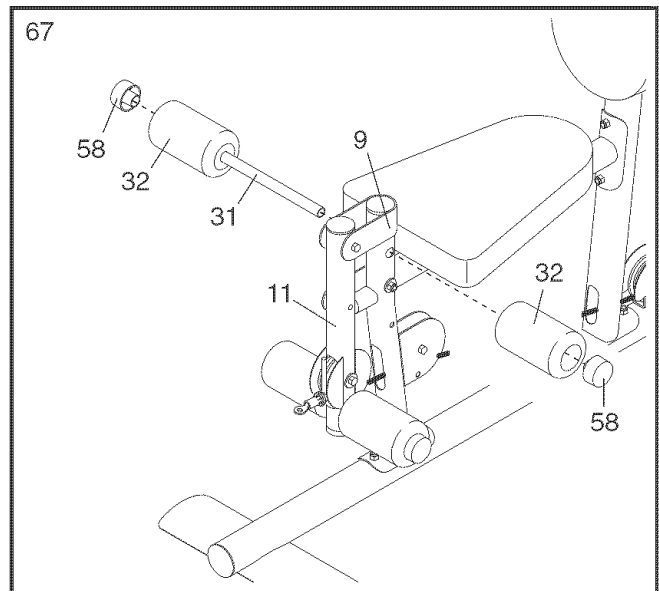

68. Attach the Knee Pad (30) to the Dip Assist (21) with four M6 x 16mm Screws (85).

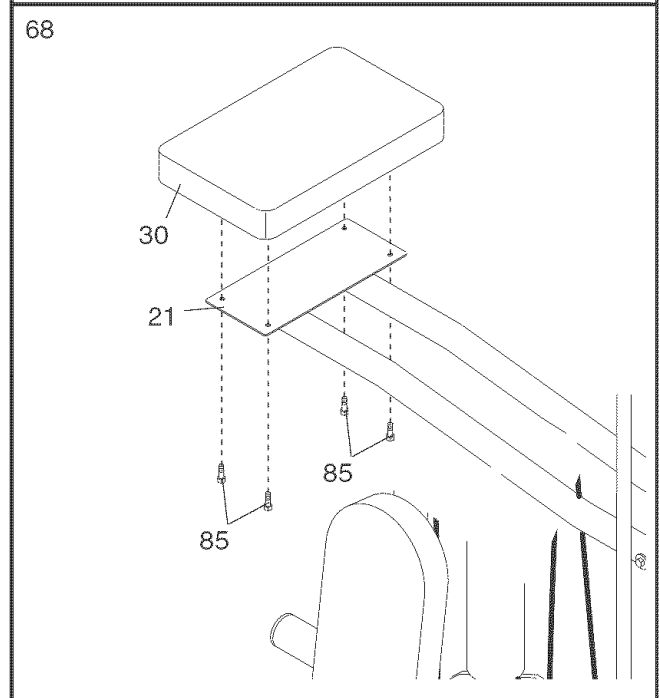

69. Make sure that all parts have been properly tightened. The use of the remaining parts will be explained in ADJUSTMENTS, beginning on the following page.

Before using the weight system, pull each cable a few times to make sure that the cables move smoothly over the pulleys. If one of the cables does not move smoothly, find and correct the problem. **IMPORTANT: If the cables are not properly installed, they may be damaged when heavy weight is used. See the CABLE DIAGRAMS on pages 26 and 27 of this manual for proper cable routing. If there is any slack in the cables, you will need to remove the slack by tightening the cables. See MAINTENANCE on page 29.**

ADJUSTMENTS

This section explains how to adjust the weight system. See the EXERCISE GUIDELINES on page 30 for important information about how to get the most benefit from your exercise program. Also, refer to the accompanying exercise guide to see the correct form for each exercise.

Make sure all parts are properly tightened each time the weight system is used. Replace any worn parts immediately. The weight system can be cleaned with a damp cloth and a mild, non-abrasive detergent. Do not use solvents.

CHANGING THE WEIGHT SETTING

To change the setting of the weight stack, insert the Weight Pin (119) under the desired Weight (35). Insert the Weight Pin so that the bent end touches the weight stack. Turn the bent end down. **Note: Be careful not to scratch yourself when reaching through the hole in a Shroud (15, 25). Do not use a Top Weight (34, not shown) by itself.**

Note: Due to the cables and pulleys, the amount of resistance at each exercise station may vary from the weight setting. Use the WEIGHT RESISTANCE CHART on page 26 to find the approximate amount of resistance at each weight station.

ATTACHING THE ACCESSORIES TO A PULLEY STATION

Attach the Handle (78) to the Leg Lever Cable (70) at the low pulley station with a Cable Clip (103). For some exercises, the Chain (110) should be attached between the Handle and the Cable with two Cable Clips. **Adjust the length of the Chain between the Handle and the Cable so that the Handle is in the correct starting position for the exercise to be performed.**

The Lat Bar (not shown), the Ab Strap (not shown), or the Handle (78) can be attached at any pulley station in the same manner. Always engage the Lock Plate (80) when using the low pulley station (see USING THE LOCK PLATE below).

USING THE LOCK PLATE

When using the low pulley station, engage the Leg Pin (83) into the Lock Plate (80) and the Leg Lever (11).

To use the Leg Lever (11), engage the Leg Pin (83) into the Lock Plate (80) and the Right Seat Frame (9).

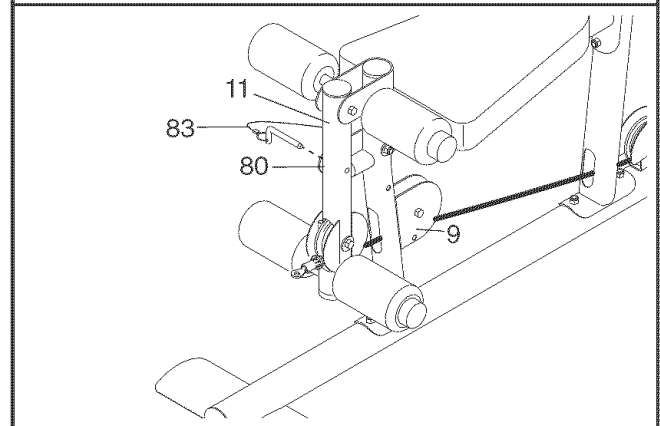
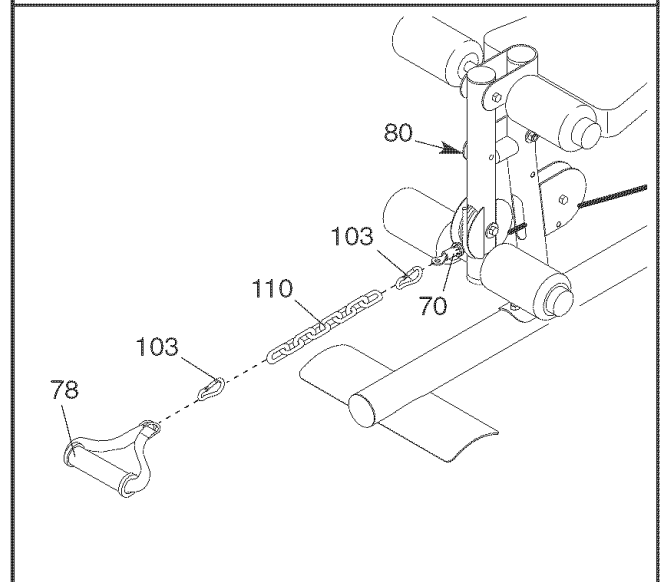
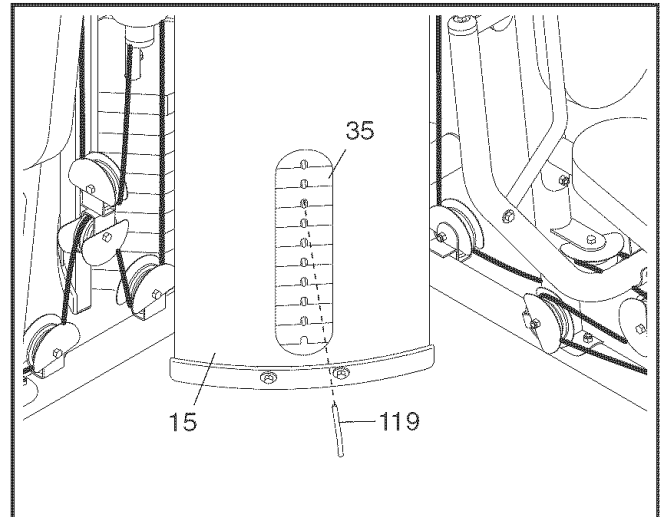

ADJUSTING THE BACKREST

To adjust the position of the left Backrest (28), disengaging the Knob (121) from the Left Upright (5) and move the Backrest to the desired position. Reengage the Knob into the Left Upright and the Backrest Frame (27). **Make sure the Knob is fully tightened.**

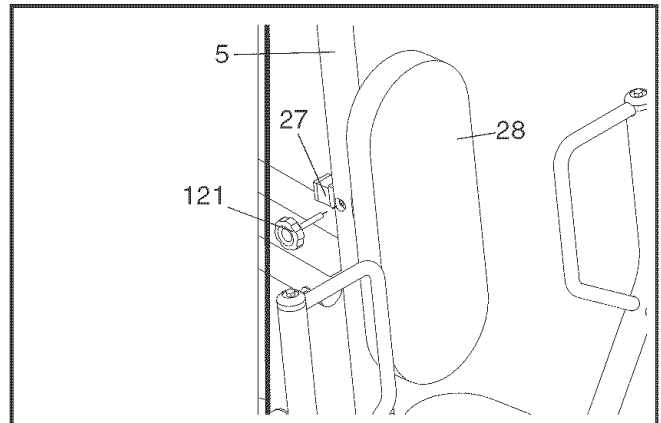

LOCKING THE WEIGHT STACK

Lock a weight stack by inserting a Lock Pin (44) through a Weight Guide (24 or 136) and securing the Lock (45) onto the Lock Pin.

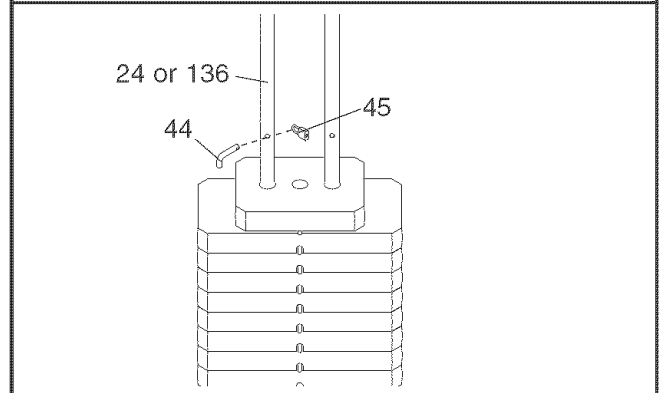

LOCKING THE DIP ASSIST

Make sure the Dip Assist (21) is locked when performing an exercise that does not require it. To lock the Dip Assist, engage the Dip Assist Latch (67) over the rod on the Rear Upright (6).

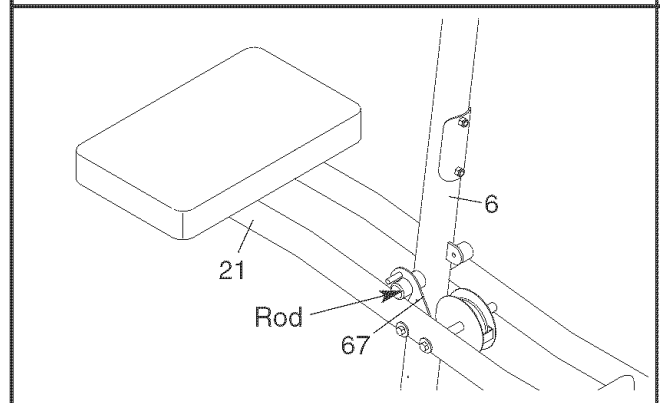

WEIGHT RESISTANCE CHART

The chart below shows the approximate weight resistance at each exercise station. "Top" refers to the 6 lb. top weight. The other numbers refer to the 12.5 lb. weight plates. Weight resistance shown for the butterfly arm station is for each arm. **Note: The actual resistance at each station may vary due to differences in individual weight plates as well as friction between the cables, pulleys, and weight guides.**

WEIGHT	HIGH PULLEY (lbs.)	BUTTERFLY ARM (lbs.)	PRESS ARM (lbs.)	LEG LEVER (lbs.)	LOW PULLEY (lbs.)	LEG PRESS (lbs.)	AB STATION (lbs.)
Top	15	26	35	34	29	27	25
1	30	35	60	44	47	58	40
2	44	45	80	62	59	89	54
3	60	54	105	77	75	110	70
4	74	63	125	102	88	147	80
5	87	77	150	111	100	183	94
6	99	82	178	125	120	208	109
7	115	90	200	147	132	238	129
8	129	112	215	172	152	263	155
9	-	-	245	-	-	296	-
10	-	-	260	-	-	327	-

CABLE DIAGRAMS

The cable diagrams below show the proper routing of the Right Stack Cable (68), the Press Cable (69), the Leg Lever Cable (70), the Lat Cable (71), and the Ab Cable (72). Use the diagram to make sure that the cables and the cable traps have been assembled correctly. If the cables have not been correctly routed, the weight bench will not function properly and damage may occur. The numbers show the correct route for each cable. **Make sure that the cable traps do not touch or bind the cables.**

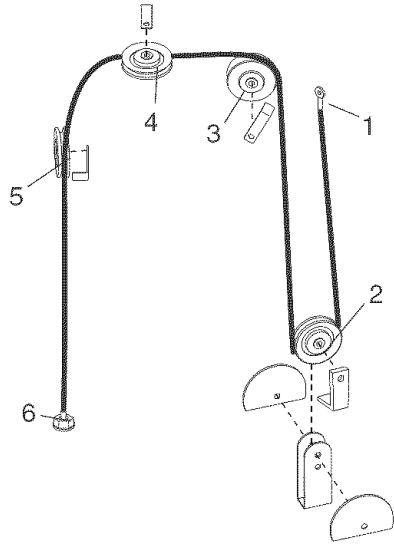

Right Stack Cable (68)
Length: 7 feet 7 inches

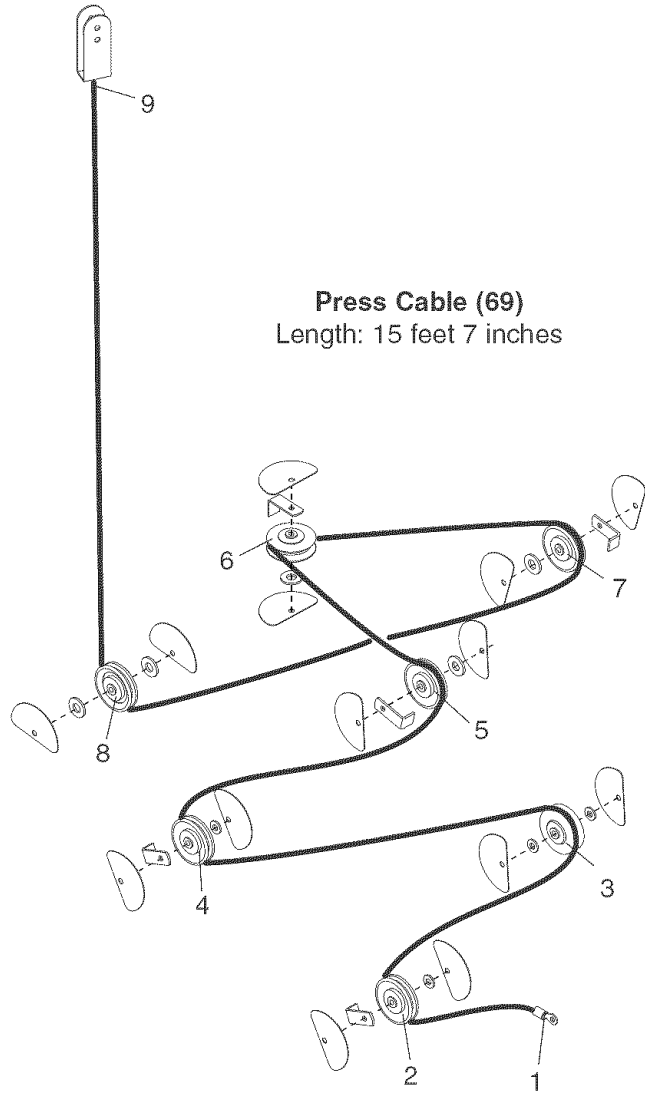

Press Cable (69)
Length: 15 feet 7 inches

Lat Cable (71)
Length: 16 feet

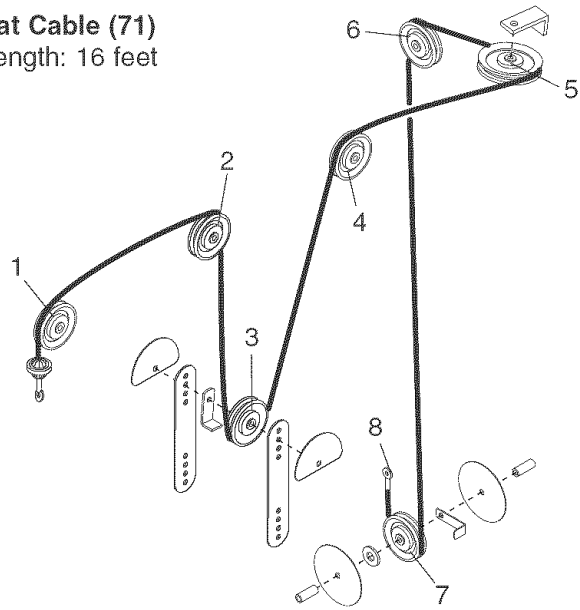

Ab Cable (72)
Length: 10 feet 3 inches

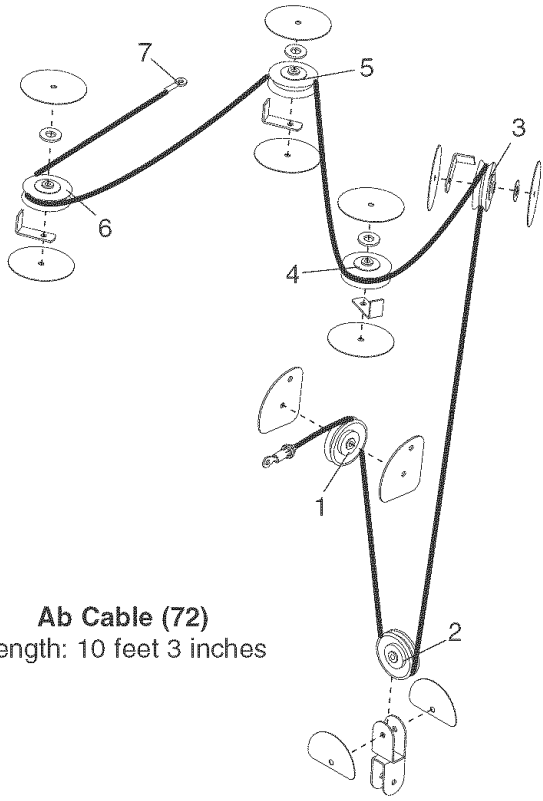

Leg Lever Cable (70)
Length: 21 feet 11 inches

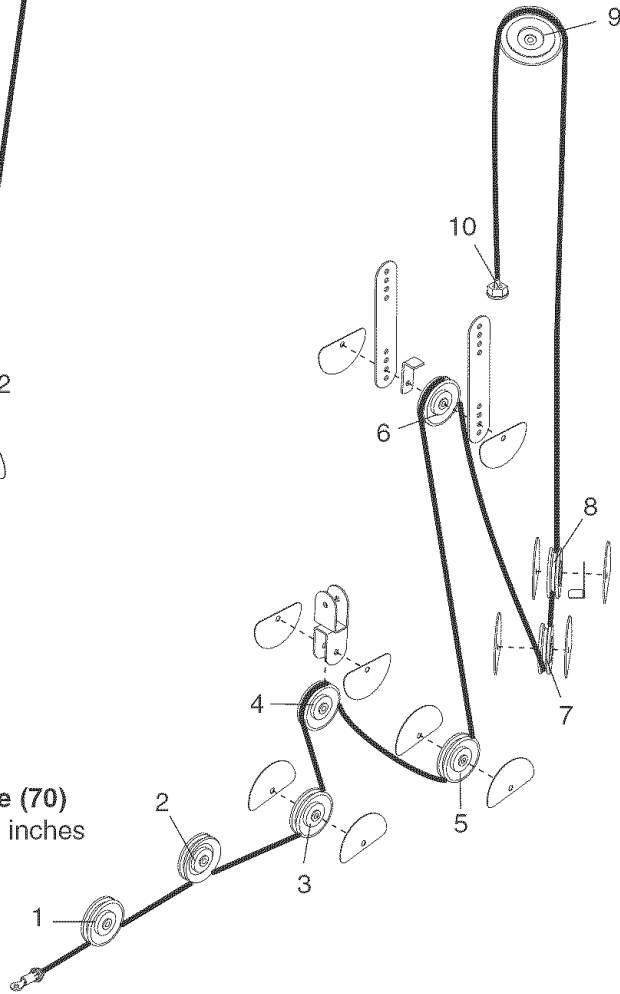

MAINTENANCE

Make sure all parts are properly tightened each time the weight system is used. Replace any worn parts immediately. The weight system can be cleaned with a damp cloth and a mild, non-abrasive detergent. Do not use solvents.

TIGHTENING THE CABLES

Woven cable, the type of cable used on the weight system, can stretch slightly when it is first used. If there is slack in the cables before resistance is felt, the cables should be tightened. To tighten the cables, first insert the weight pin into the middle of the weight stack. Slack can be removed from these cables several ways:

- **See drawing 1.** Tighten the M8 Nylon Locknut (115) that connects the end of a cable to a “U”-bracket (50).
- **See drawing 1.** Remove the M10 Nylon Locknut (114) and the M10 x 52mm Bolt (102) from the Small Cable Trap (48), 90mm Pulley (39), the two Half Finger Guards (42), and a “U”-bracket (50). Reattach the Pulley, Cable Trap, and Finger Guards to the other hole in the “U”-bracket. **Make sure that the Cable Trap and Finger Guards are oriented as shown and that the cable and Pulley move smoothly.**
- **See drawing 2.** Remove the M10 Nylon Locknut (114) and the M10 x 52mm Bolt (102) from the Small Cable Trap (48), the 90mm Pulley (39), the two Half Finger Guards (42), and the two Pulley Plates (51). Reattach the Pulley, Cable Trap, and Finger Guards to the next closer hole to the center of the Pulley Plates. **Make sure that the Cable Trap is oriented to hold the cable in the groove of the Pulley, that the Finger Guards are oriented as shown, and that the Cable and Pulley move smoothly.**
- **See drawing 3.** Loosen the M12 Nut (128) on a cable. Tighten the cable into the Weight Tube (not shown) until the slack is removed from the cables. Retighten the M12 Nut against the M12 Washer (129).

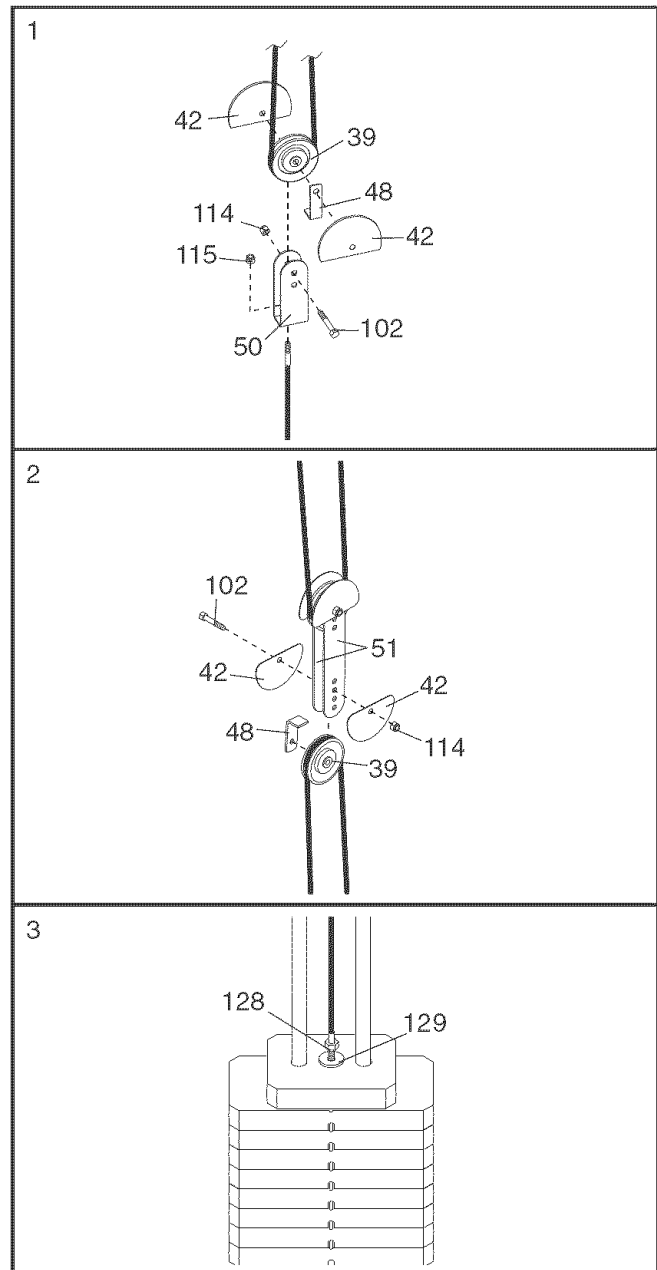

Do not overtighten the cables. If the cables are overtightened, the top weight will be lifted off the weight stack. If a cable tends to slip off the pulleys often, it may have become twisted. Remove the cable and re-install it. If the cables need to be replaced, see ORDERING REPLACEMENT PARTS on the back cover of this manual.

EXERCISE GUIDELINES

THE FOUR BASIC TYPES OF WORKOUTS

Muscle Building

To increase the size and strength of your muscles, push them close to their maximum capacity. Your muscles will continually adapt and grow as you progressively increase the intensity of your exercise. You can adjust the intensity level of an individual exercise in two ways:

- by changing the amount of resistance used
- by changing the number of repetitions or sets performed. (A “repetition” is one complete cycle of an exercise, such as one sit-up. A “set” is a series of repetitions.)

The proper amount of resistance for each exercise depends upon the individual user. You must gauge your limits and select the amount of resistance that is right for you. Begin with 3 sets of 8 repetitions for each exercise you perform. Rest for 3 minutes after each set. When you can complete 3 sets of 12 repetitions without difficulty, increase the amount of resistance.

Toning

You can tone your muscles by pushing them to a moderate percentage of their capacity. Select a moderate amount of resistance and increase the number of repetitions in each set. Complete as many sets of 15 to 20 repetitions as possible without discomfort. Rest for 1 minute after each set. Work your muscles by completing more sets rather than by using high amounts of resistance.

Weight Loss

To lose weight, use a low amount of resistance and increase the number of repetitions in each set. Exercise for 20 to 30 minutes, resting for a maximum of 30 seconds between sets.

Cross Training

Cross training is an efficient way to get a complete and well-balanced fitness program. An example of a balanced program is:

- Plan strength training workouts on Monday, Wednesday, and Friday.
- Plan 20 to 30 minutes of aerobic exercise, such as running on a treadmill or riding on an elliptical or exercise bike, on Tuesday and Thursday.
- Rest from both strength training and aerobic exercise for at least one full day each week to give your body time to regenerate.

The combination of strength training and aerobic exercise will reshape and strengthen your body, plus develop your heart and lungs.

PERSONALIZING YOUR EXERCISE PROGRAM

Determining the exact length of time for each workout, as well as the number of repetitions or sets completed, is an individual matter. It is important to avoid overdoing it during the first few months of your exercise program. You should progress at your own pace and be sensitive to your body's signals. If you experience pain or dizziness at any time while exercising, stop immediately and begin cooling down. Find out what is wrong before continuing. Remember that adequate rest and a proper diet are important factors in any exercise program.

WARMING UP

Begin each workout with 5 to 10 minutes of stretching and light exercise to warm up. Warming up prepares your body for more strenuous exercise by increasing circulation, raising your body temperature and delivering more oxygen to your muscles.

WORKING OUT

Each workout should include 6 to 10 different exercises. Select exercises for every major muscle group, emphasizing areas that you want to develop most. To give balance and variety to your workouts, vary the exercises from session to session.

Schedule your workouts for the time of day when your energy level is the highest. Each workout should be followed by at least one day of rest. Once you find the schedule that is right for you, stick with it.

EXERCISE FORM

Maintaining proper form is an essential part of an effective exercise program. This requires moving through the full range of motion for each exercise, and moving only the appropriate parts of the body. Exercising in an uncontrolled manner will leave you feeling exhausted. On the exercise guide accompanying this manual you will find photographs showing the correct form for several exercises, and a list of the muscles affected. Refer to the muscle chart on the next page to find the names of the muscles.

The repetitions in each set should be performed smoothly and without pausing. The exertion stage of each repetition should last about half as long as the return stage. Proper breathing is important. Exhale during the exertion stage of each repetition and inhale during the return stroke. Never hold your breath.

Rest for a short period of time after each set. The ideal resting periods are:

- Rest for three minutes after each set for a muscle building workout.
- Rest for one minute after each set for a toning workout.
- Rest for 30 seconds after each set for a weight loss workout.

Plan to spend the first couple of weeks familiarizing yourself with the equipment and learning the proper form for each exercise.

COOLING DOWN

End each workout with 5 to 10 minutes of stretching. Include stretches for both your arms and legs. Move

slowly as you stretch and do not bounce. Ease into each stretch gradually and go only as far as you can without strain. Stretching at the end of each workout is an effective way to increase flexibility.

STAYING MOTIVATED

For motivation, keep a record of each workout. List the date, the exercises performed, the resistance used, and the numbers of sets and repetitions completed. Record your weight and key body measurements at the end of every month. Remember, the key to achieving the greatest results is to make exercise a regular and enjoyable part of your everyday life.

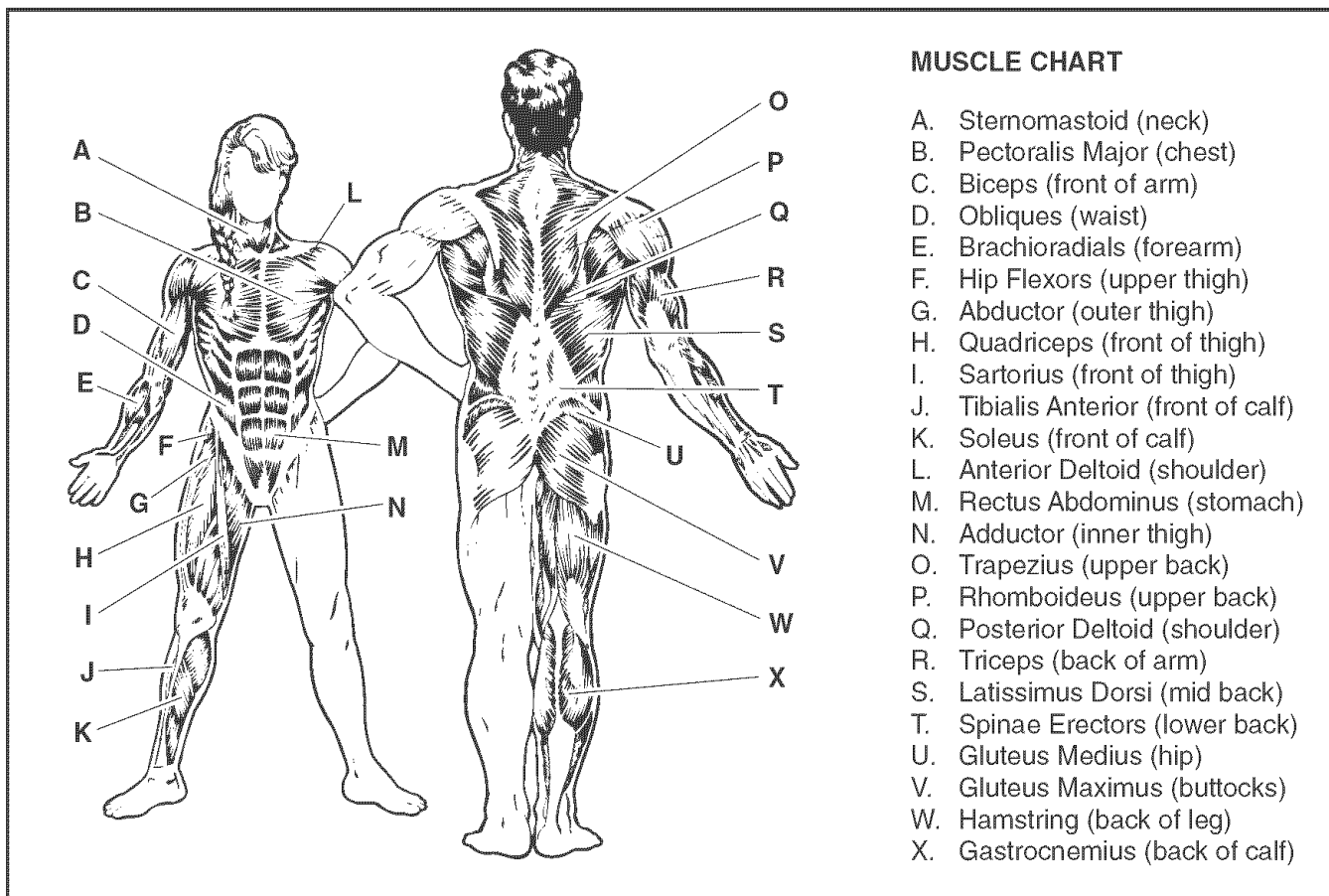

PART IDENTIFICATION CHART—Model No. 831.154031

R0804A

Refer to the drawings below to identify small parts used in assembly. The number in parentheses by each drawing is the key number of the part, from the PART LIST in the center of this manual. **Note: Some small parts may have been pre-attached. If a part is not in the parts bag, check to see if it has been pre-attached. If a part is missing, call toll-free 1-877-992-5999.**

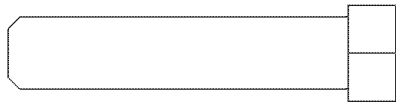

M10 x 45mm Bolt (138)

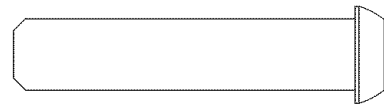

M10 x 45mm Button Bolt (105)

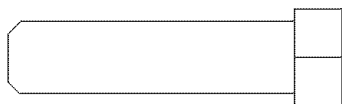

M10 x 38mm Screw (82)

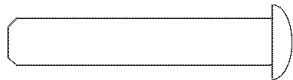

M6 x 35mm Screw (139)

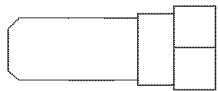

M8 x 22mm Shoulder Bolt (88)

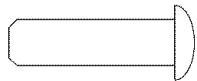

M6 x 22mm Bolt (109)

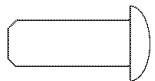

M6 x 16mm Screw (85)



M4 x 16mm Self-tapping Screw (113)

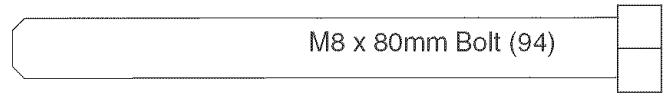

M8 x 80mm Bolt (94)



M8 x 75mm Carriage Bolt (84)

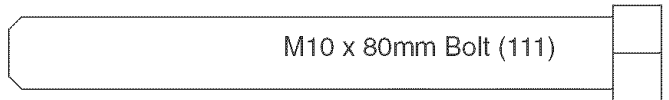

M10 x 80mm Bolt (111)

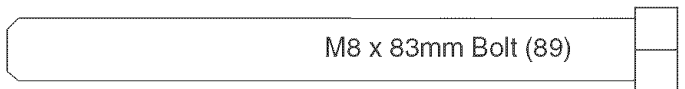

M8 x 83mm Bolt (89)

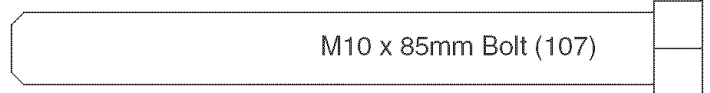

M10 x 85mm Bolt (107)



M8 x 86mm Shoulder Bolt (86)

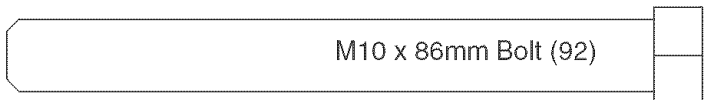

M10 x 86mm Bolt (92)

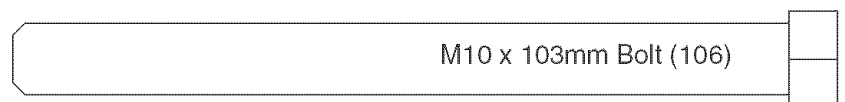

M10 x 103mm Bolt (106)

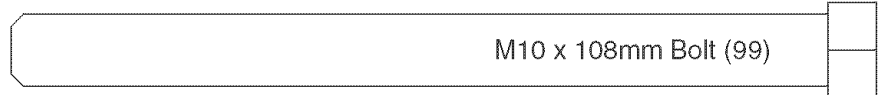

M10 x 108mm Bolt (99)

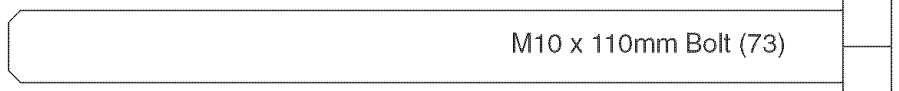

M10 x 110mm Bolt (73)

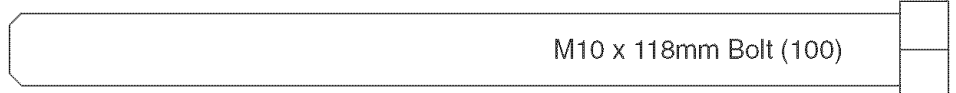

M10 x 118mm Bolt (100)



M10 x 135mm Bolt (98)

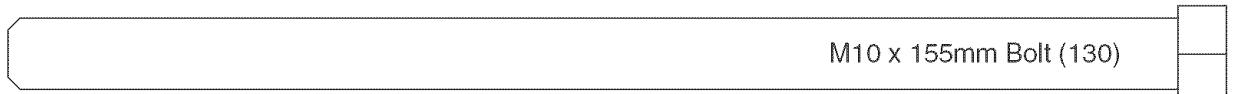

M10 x 155mm Bolt (130)



M6 Locknut (135)

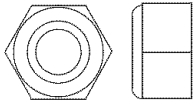

M8 Nylon Locknut (115)

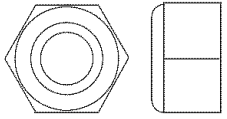

M10 Nylon Locknut (114)

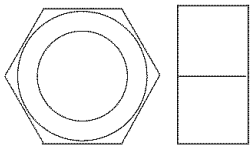

M12 Nut (128)

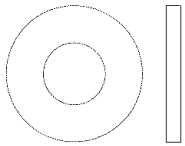

M8 Washer (117)

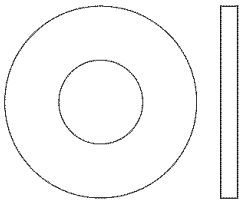

M10 Washer (116)

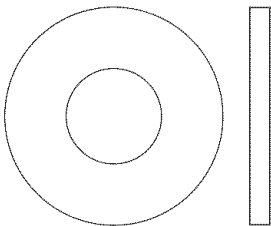

M12 Washer (129)

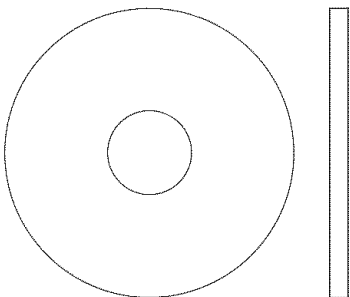

M10 Large Washer (134)

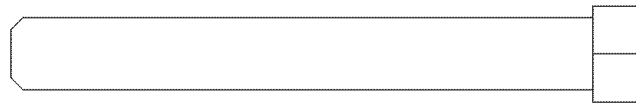

M10 x 77mm Bolt (133)

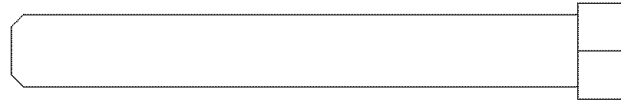

M10 x 75mm Bolt (104)



M8 x 72mm Bolt (91)

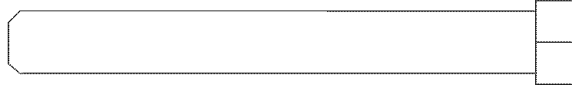

M8 x 70mm Bolt (97)



M8 x 69mm Shoulder Bolt (87)

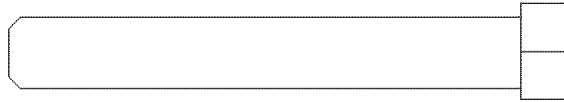

M10 x 68mm Bolt (93)

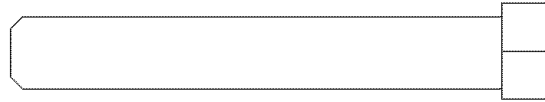

M10 x 65mm Bolt (96)

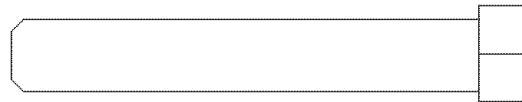

M10 x 61mm Bolt (90)

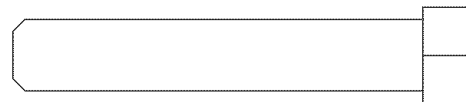

M10 x 55mm Bolt (137)

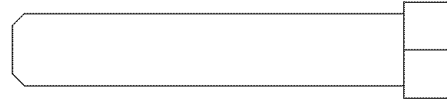

M10 x 52mm Bolt (102)

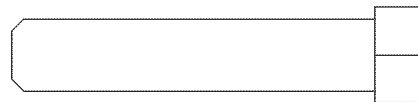

M10 x 48mm Bolt (101)

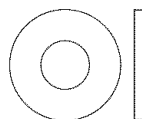

M6 Washer (132)



M4 Washer (131)

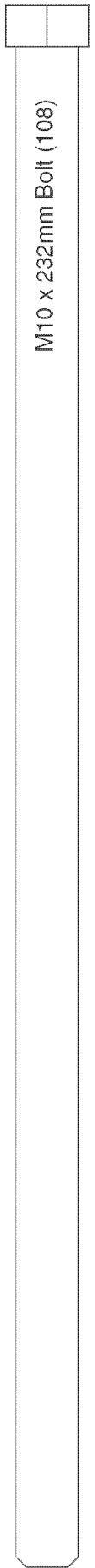

M10 x 232mm Bolt (108)

PART LIST—Model No. 831.154031

R0804A

Key No.	Qty.	Description	Key No.	Qty.	Description
1	1	Right Base	55	11	50mm Round Inner Cap
2	1	Left Base	56	2	Press Arm Cap
3	1	Rear Base	57	1	56mm Round Inner Cap
4	1	Right Upright	58	4	Foam Cap
5	1	Left Upright	59	4	Arm Bushing
6	1	Rear Upright	60	1	50mm Outer Cap
7	1	Right Top Frame	61	4	32mm Round Inner Cap
8	1	Left Top Frame	62	2	Dip Arm Cap
9	1	Right Seat Frame	63	2	25mm Outer Cap
10	1	Left Seat Frame	64	1	Cross Brace
11	1	Leg Lever	65	4	Weight Bumper
12	1	Leg Press Frame	66	2	Weight Tube Bumper
13	1	Press Frame	67	1	Dip Assist Latch
14	2	Press Arm	68	1	Right Stack Cable
15	1	Front Shroud	69	1	Press Cable
16	2	Press Handle	70	1	Leg Lever Cable
17	1	Right Butterfly Arm	71	1	Lat Cable
18	1	Left Butterfly Arm	72	1	Ab Cable
19	1	Pull-up Arm	73	2	M10 x 110mm Bolt
20	1	Dip Arm	74	2	40mm Spacer
21	1	Dip Assist	75	7	12mm Spacer
22	1	Butterfly Frame	76	1	Leg Bumper
23	1	Foot Plate	77	11	19mm Spacer
24	2	Rear Weight Guide	78	1	Handle
25	1	Rear Shroud	79	2	Large Foam Pad
26	4	Shroud Cover	80	1	Lock Plate
27	1	Backrest Frame	81	2	Left Base Bushing
28	1	Right Backrest	82	4	M10 x 38mm Screw
29	2	Seat	83	1	Leg Pin
30	1	Knee Pad	84	10	M8 x 75mm Carriage Bolt
31	2	Pad Tube	85	18	M6 x 16mm Screw
32	4	Small Foam Pad	86	1	M8 x 86mm Shoulder Bolt
33	1	Left Backrest	87	1	M8x 69mm Shoulder Bolt
34	2	Top Weight	88	2	M8 x 22mm Shoulder Bolt
35	18	Weight	89	8	M8 x 83mm Bolt
36	1	Long Weight Tube	90	3	M10 x 61mm Bolt
37	1	Left Upright Plate	91	2	M8 x 72mm Bolt
38	1	Rear Upright Plate	92	2	M10 x 86mm Bolt
39	24	90mm Pulley	93	2	M10 x 68mm Bolt
40	7	"V"-pulley	94	11	M8 x 80mm Bolt
41	2	115mm Pulley	95	2	Quarter Guard
42	32	Half Finger Guard	96	3	M10 x 65mm Bolt
43	10	Full Finger Guard	97	4	M8 x 70mm Bolt
44	2	Lock Pin	98	1	M10 x 135mm Bolt
45	2	Lock	99	4	M10 x 108mm Bolt
46	1	Lat Bar	100	1	M10 x 118mm Bolt
47	2	Handgrip	101	5	M10 x 48mm Bolt
48	11	Small Cable Trap	102	5	M10 x 52mm Bolt
49	6	Cable Trap	103	3	Cable Clip
50	1	"U"-bracket	104	1	M10 x 75mm Bolt
51	2	Pulley Plates	105	2	M10 x 45mm Button Bolt
52	1	Double "U"-bracket	106	1	M10 x 103mm Bolt
53	3	50mm Large Round Inner Cap	107	1	M10 x 85mm Bolt
54	7	63mm Round Inner Cap	108	3	M10 x 232mm Bolt

Key No.	Qty.	Description	Key No.	Qty.	Description
109	8	M6 x 22mm Bolt	127	1	25mm Round Inner Cap
110	1	Chain	128	2	M12 Nut
111	6	M10 x 80mm Bolt	129	3	M12 Washer
112	6	M4 x 12mm Self-tapping Screw	130	2	M10 x 155mm Bolt
113	2	M4 x 16mm Self-tapping Screw	131	1	M4 Washer
114	45	M10 Nylon Locknut	132	9	M6 Washer
115	40	M8 Nylon Locknut	133	1	M10 x 77mm Bolt
116	50	M10 Washer	134	4	M10 Large Washer
117	20	M8 Washer	135	8	M6 Locknut
118	1	Ab Strap	136	2	Front Weight Guide
119	2	Weight Pin	137	1	M10 x 55mm Bolt
120	1	Backrest Frame Bushing	138	1	M10 x 45mm Bolt
121	1	Knob	139	1	M6 x 35mm Screw
122	2	Guard	140	2	40mm x 20mm Inner Cap
123	1	Short Weight Tube	#	1	User's Manual
124	1	16mm Spacer	#	1	Exercise Guide
125	1	Large Cable Trap	#	1	Allen Wrench
126	2	28mm Round Inner Cap	#	2	Grease Packet

Note: “#” indicates a non-illustrated part. Specifications are subject to change without notice. See the back cover of the user's manual for information about ordering replacement parts. If a part is missing, call toll-free 1-877-992-5999.

EXPLODED DRAWING—Model No. 831.154031

R0804A

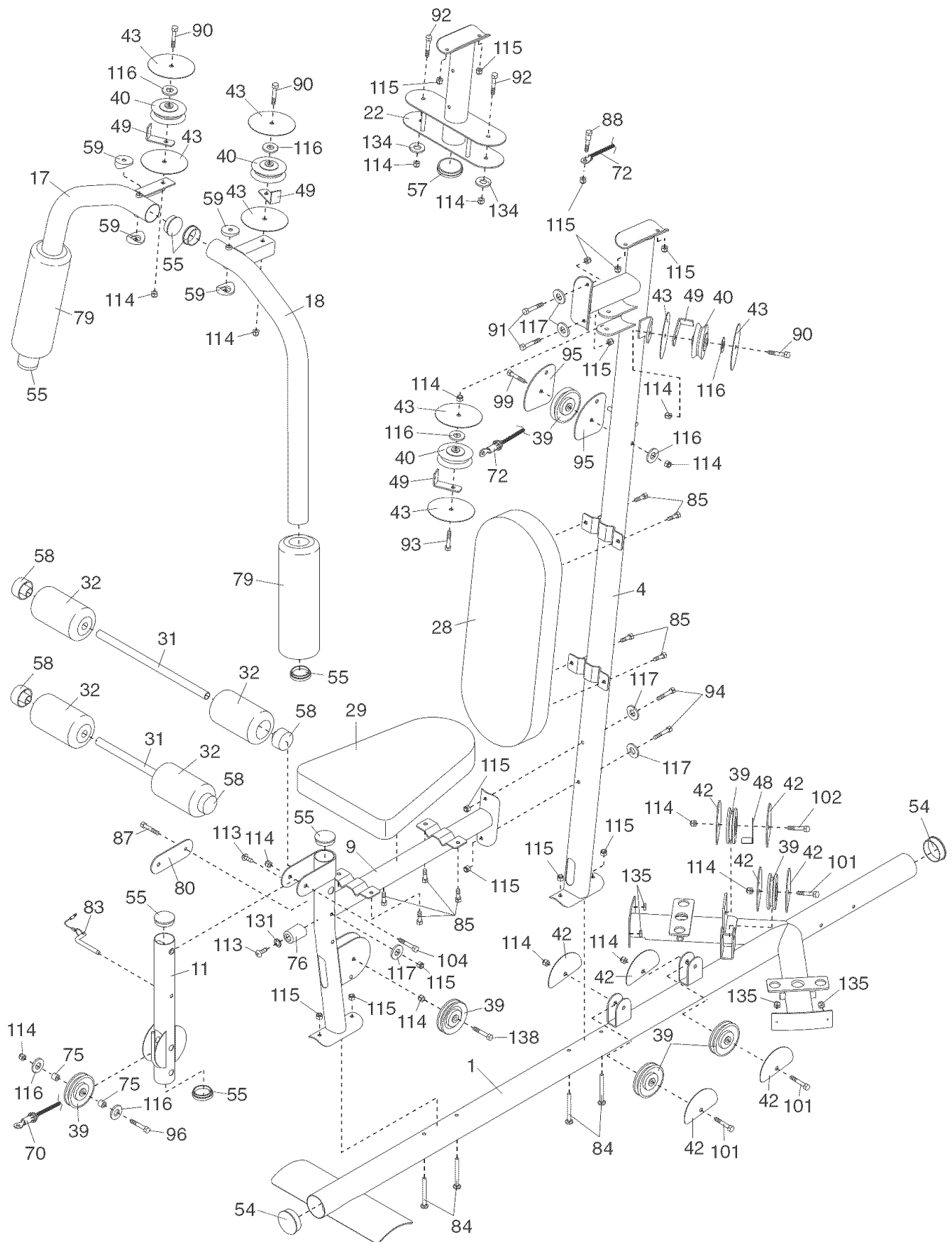

EXPLODED DRAWING—Model No. 831.154031

R0804A

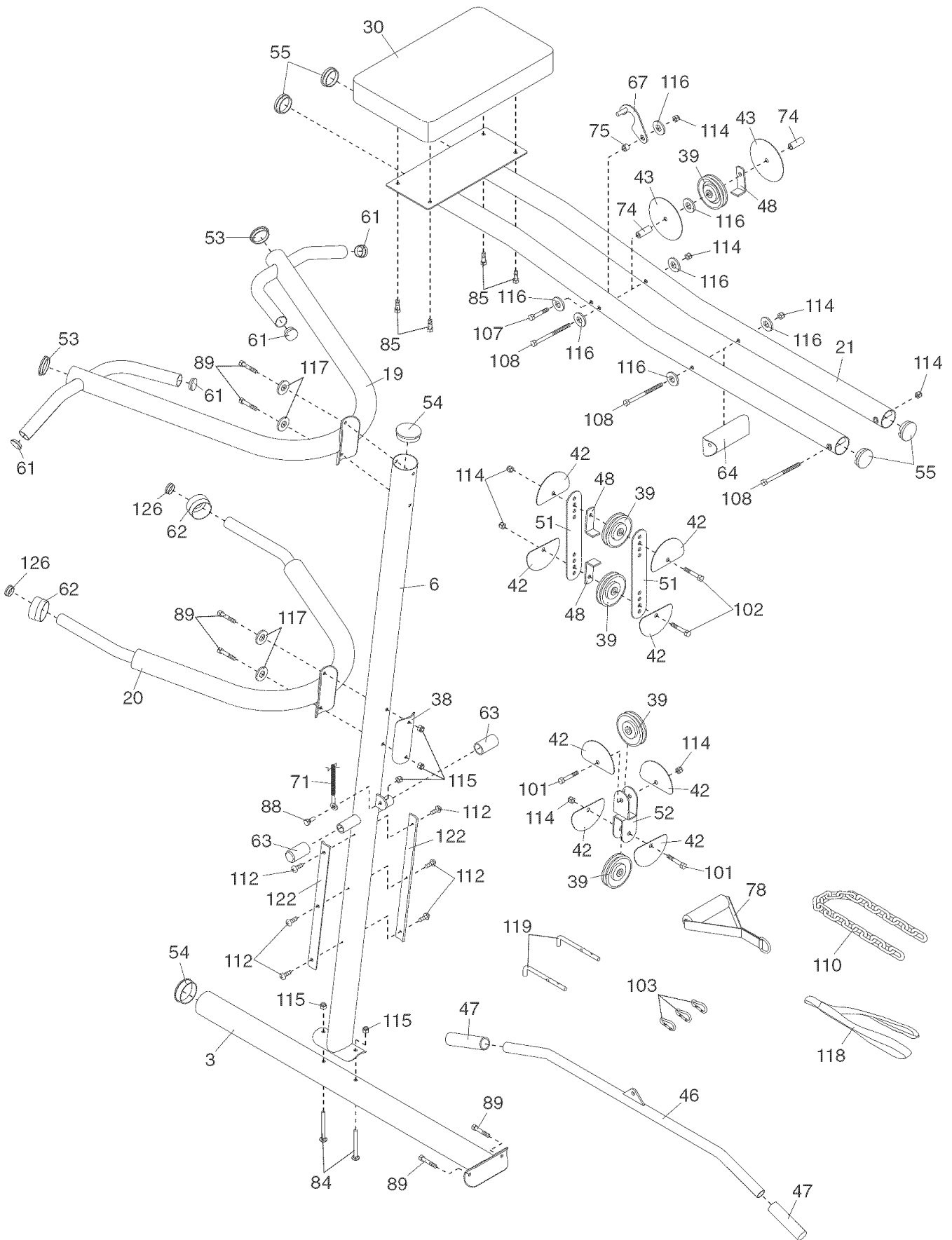

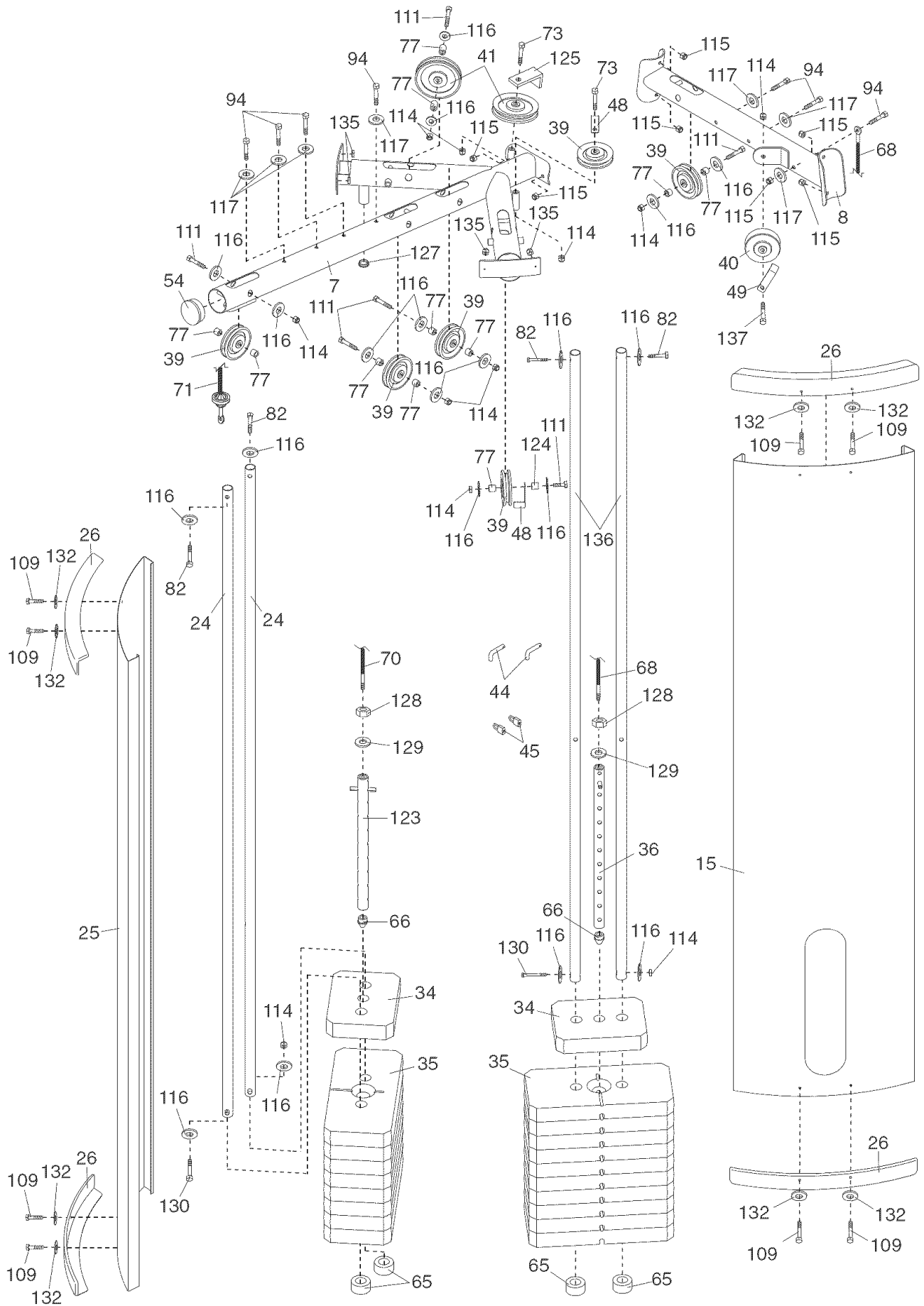

Get it fixed, at your home or ours!

Your Home

For repair – **in your home** – of **all** major brand appliances, lawn and garden equipment, or heating and cooling systems, **no matter who made it, no matter who sold it!**

For the replacement parts, accessories, and user's manuals that you need to do-it-yourself.

For Sears professional installation of home appliances and items like garage door openers and water heaters.

1-800-4-MY-HOME®

(1-800-469-4663)

www.sears.com

Anytime, day or night

(U.S.A. and Canada)

www.sears.ca

Our Home

For repair of carry-in products like vacuums, lawn equipment, and electronics, call or go on-line for the location of your nearest **Sears Parts and Repair Center.**

1-800-488-1222 Anytime, day or night (U.S.A. only)

www.sears.com

To purchase a protection agreement (U.S.A.) or maintenance agreement (Canada) on a product serviced by Sears:

1-800-827-6655 (U.S.A.)

1-800-361-6665 (Canada)

Para pedir servicio de reparación a domicilio, y para ordenar piezas:

1-888-SU-HOGARSM (1-888-784-6427)

SEARS

® Registered Trademark / ™ Trademark / SM Service Mark of Sears, Roebuck and Co.
© Marca Registrada / ™ Marca de Fábrica / SM Marca de Servicio de Sears, Roebuck and Co.

FULL 90-DAY WARRANTY

For 90 days from the date of purchase, if failure occurs due to defect in material or workmanship in this WEIGHT SYSTEM EXERCISER, contact the nearest Sears Service Center throughout the United States and Sears will repair or replace the WEIGHT SYSTEM EXERCISER, free of charge.

This warranty does not apply when the WEIGHT SYSTEM EXERCISER is used commercially or for rental purposes.

This warranty gives you specific legal rights, and you may also have other rights which vary from state to state.

Sears, Roebuck and Co., Dept 817WA, Hoffman Estates, IL 60179