

PRO-FORM 365s CrossWalk

Model No. 831.295030

Serial No. _____

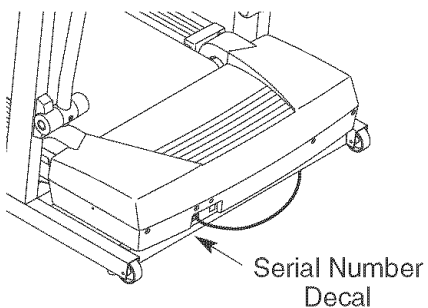

- Assembly
- Operation
- Maintenance
- Part List and Drawing

CAUTION

Read all precautions and instructions in this manual before using this equipment. Save this manual for future reference.

TREADMILL EXERCISER User's Manual

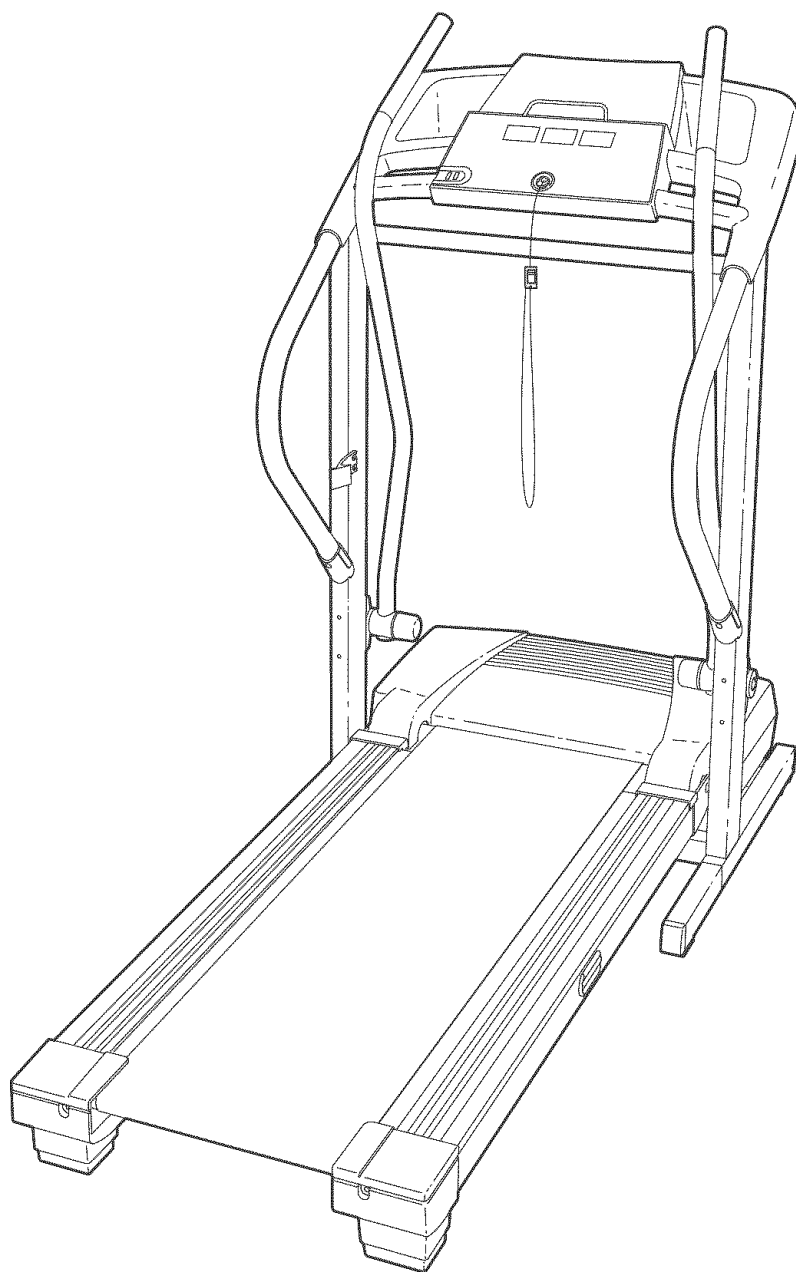

Sears, Roebuck and Co., Hoffman Estates, IL 60179

PRO-FORM® 365s **CrossWalk**

TABLE OF CONTENTS

IMPORTANT PRECAUTIONS	3
BEFORE YOU BEGIN	5
ASSEMBLY	6
OPERATION AND ADJUSTMENT	10
HOW TO FOLD AND MOVE THE TREADMILL	14
TROUBLESHOOTING	16
CONDITIONING GUIDELINES	18
ORDERING REPLACEMENT PARTS	Back Cover
FULL 90 DAY WARRANTY	Back Cover

Note: An EXPLODED DRAWING and a PART LIST are attached in the center of this manual.

IMPORTANT PRECAUTIONS

▲ WARNING: To reduce the risk of burns, fire, electric shock, or injury to persons, read the following important precautions and information before operating the treadmill.

1. It is the responsibility of the owner to ensure that all users of this treadmill are adequately informed of all warnings and precautions.
2. Use the treadmill only as described.
3. Place the treadmill on a level surface, with at least eight feet of clearance behind it and two feet on each side. Do not place the treadmill on any surface that blocks air openings. To protect the floor or carpet from damage, place a mat under the treadmill.
4. Keep the treadmill indoors, away from moisture and dust. Do not put the treadmill in a garage or covered patio, or near water.
5. Do not operate the treadmill where aerosol products are used or where oxygen is being administered.
6. Keep children under the age of 12 and pets away from the treadmill at all times.
7. The treadmill should be used only by persons weighing 250 pounds or less.
8. Never allow more than one person on the treadmill at a time.
9. Wear appropriate exercise clothes when using the treadmill. Do not wear loose clothes that could become caught in the treadmill. Athletic support clothes are recommended for both men and women. *Always wear athletic shoes. Never use the treadmill with bare feet, wearing only stockings, or in sandals.*
10. When connecting the power cord (see page 10), plug the power cord into a surge suppressor (not included) and plug the surge suppressor into a grounded circuit capable of carrying 15 or more amps. No other appliance should be on the same circuit. Do not use an extension cord.
11. Use only a single-outlet surge suppressor that meets all of the specifications described on page 10. To purchase a surge suppressor, see your local Sears store or call 1-800-366-7278 and order part number 146148, or see your local electronics store.
12. Failure to use a properly functioning surge suppressor could result in damage to the control system of the treadmill. If the control system is damaged, the walking belt may change speed or stop unexpectedly, which may result in a fall and serious injury.
13. Keep the power cord and the surge suppressor away from heated surfaces.
14. Never move the walking belt while the power is turned off. Do not operate the treadmill if the power cord or plug is damaged, or if the treadmill is not working properly. (See **BEFORE YOU BEGIN** on page 5 if the treadmill is not working properly.)
15. Never start the treadmill while you are standing on the walking belt. Always hold the handrails while using the treadmill.
16. The treadmill is capable of high speeds. Adjust the speed in small increments to avoid sudden jumps in speed.
17. The pulse sensor is not a medical device. Various factors, including your movement, may affect the accuracy of heart rate readings. The sensor is intended only as an exercise aid in determining heart rate trends in general.
18. Do not use the hand weights at speeds faster than walking speeds. Using weights and not holding the handrails may compromise your ability to maintain your balance. Exercises using weights should be attempted only by experienced users.
19. Never leave the treadmill unattended while it is running. Always remove the key and unplug the power cord when the treadmill is not in use.
20. Do not attempt to raise, lower, or move the treadmill until it is properly assembled. (See **ASSEMBLY** on page 6, and **HOW TO FOLD AND MOVE THE TREADMILL** on page 14.) You must be able to safely lift 45 pounds (20 kg) to raise, lower, or move the treadmill.

21. When folding or moving the treadmill, make sure that the storage latch is fully closed.

22. Inspect and properly tighten all parts of the treadmill regularly.

23. Never insert any object into any opening.

24. **DANGER:** Always unplug the power cord immediately after use, before cleaning the treadmill, and before performing the

maintenance and adjustment procedures described in this manual. Never remove the motor hood unless instructed to do so by an authorized service representative. Servicing other than the procedures in this manual should be performed by an authorized service representative only.

25. This treadmill is intended for in-home use only. Do not use this treadmill in a commercial, rental, or institutional setting.

WARNING: Before beginning this or any exercise program, consult your physician. This is especially important for persons over the age of 35 or persons with pre-existing health problems. Read all instructions before using. Sears assumes no responsibility for personal injury or property damage sustained by or through the use of this product.

SAVE THESE INSTRUCTIONS

The decals shown have been placed on your treadmill. If a decal is missing, or if it is not legible, please call toll-free 1-888-533-1333 and order a free replacement decal (see the front cover of this manual). Apply the decal in the location shown. Note: The decals are not shown at actual size.

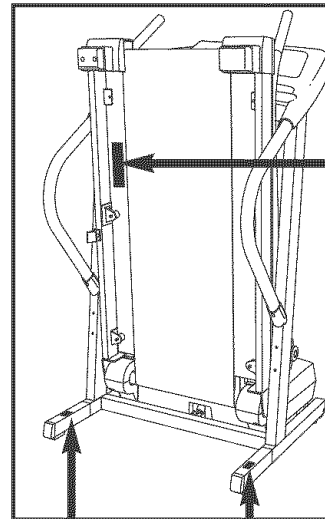
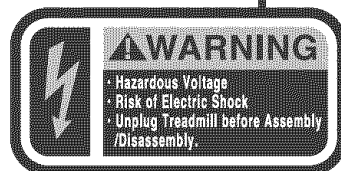
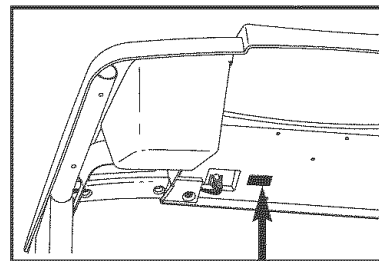

WARNING:
Protect yourself and others from risk of serious injury. Read the user's manual and :

- Stand only on the side rails when starting or stopping treadmill.
- Change speed in small increments.
- Hold handrails to prevent falling, and always wear the safety clip while operating treadmill.
- Stop if you feel faint, dizzy, or short of breath.
- Fully engage storage latch before treadmill is moved or stored.
- Reduce incline to its lowest level before folding treadmill into storage position.

• Never allow children on or around treadmill.

• Remove key when not in use.

• Keep clothing, fingers, and hair away from moving belt.

• Never try to adjust or fix the belt while it is moving.

• Always wear athletic shoes while operating treadmill.

BEFORE YOU BEGIN

Thank you for selecting the new PROFORM® CROSSWALK 365s treadmill. The CROSSWALK 365s treadmill combines advanced technology with innovative design to help you get the most from your exercise in the convenience of your home. And when you're not exercising, the CROSSWALK 365s treadmill can be folded up, requiring less than half the floor space of other treadmills.

For your benefit, read this manual carefully before using the treadmill. If you have questions after reading

this manual, call 1-800-4-MY-HOME® (1-800-469-4663). To help us assist you, please note the product model number and serial number before calling. The model number of the treadmill is 831.295030. The serial number can be found on a decal attached to the treadmill (see the front cover of this manual for the location).

Before reading further, please review the drawing below and familiarize yourself with the labeled parts.

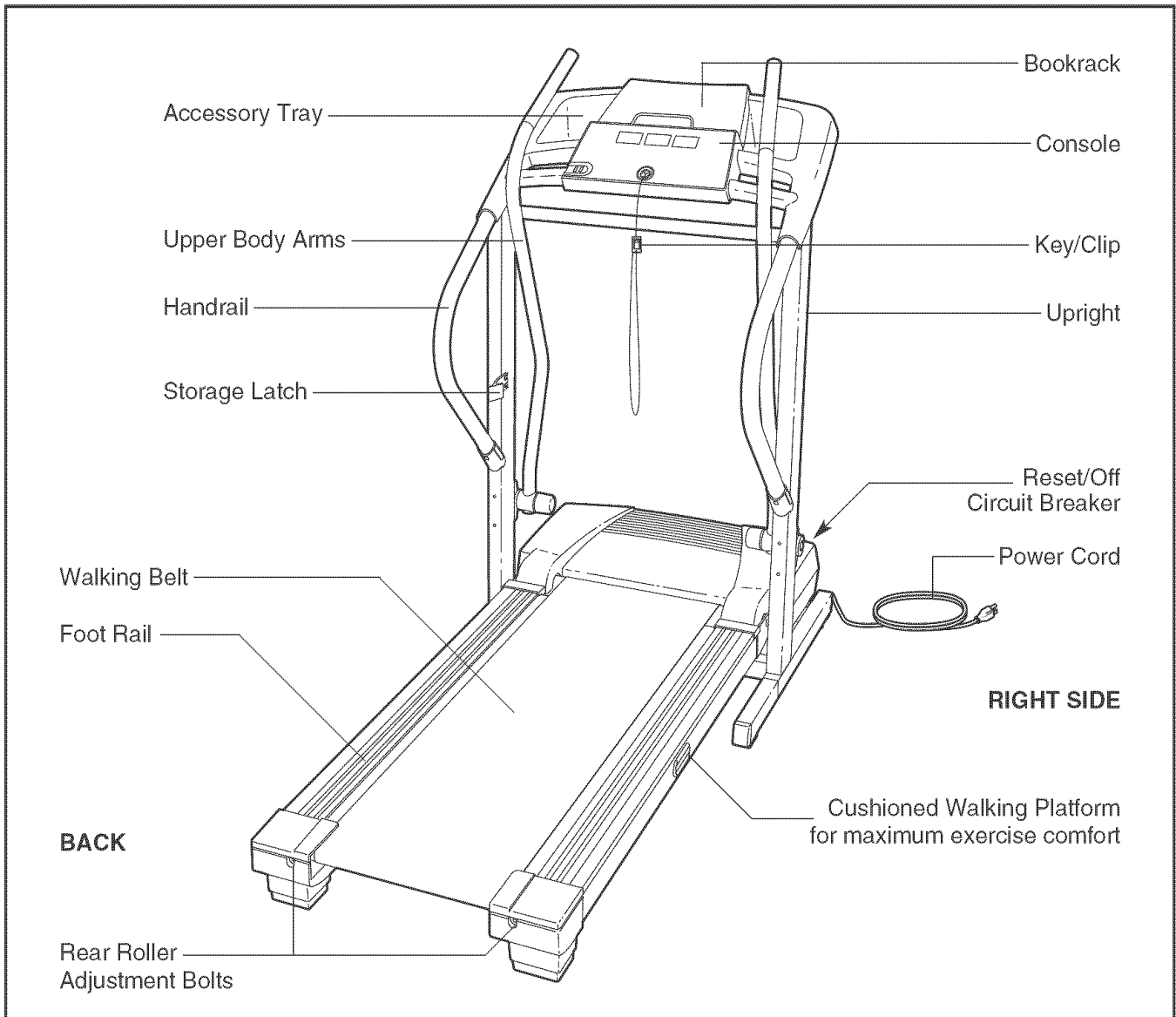

ASSEMBLY

Assembly requires two persons. Set the treadmill in a cleared area and remove all packing materials. Do not dispose of the packing materials until assembly is completed.

Note: The underside of the treadmill walking belt is coated with high-performance lubricant. During shipping, a small amount of lubricant may be transferred to the top of the walking belt or the shipping carton. This is a normal condition and does not affect treadmill performance. If there is lubricant on top of the walking belt, simply wipe off the lubricant with a soft cloth and a mild, non-abrasive cleaner.

Assembly requires the included allen wrenches  and your own phillips screwdriver , rubber mallet , and adjustable wrench .

For help identifying the assembly hardware, see the drawings below. If a part is not in the parts bag, first check to see if it has been pre-assembled. If a part is missing, call toll-free 1-888-533-1333.

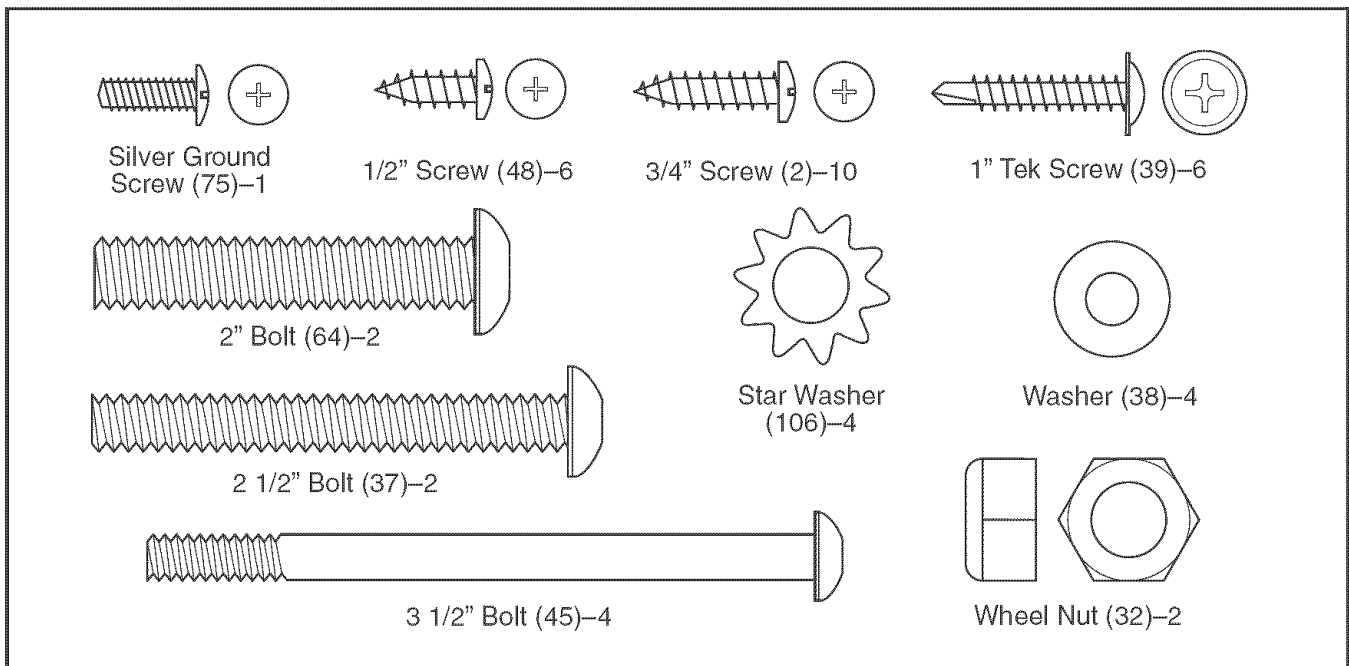

1. Make sure that the power cord is unplugged.



With the help of another person, carefully raise the Uprights (69) to the vertical position. Insert one of the Extension Legs (63) into the treadmill as shown. (Note: It may be helpful to tip the Uprights as you insert the Extension Leg.) Make sure that the Base Pad (61) is under the Extension Leg.

Insert the other Extension Leg (63) in the same way.

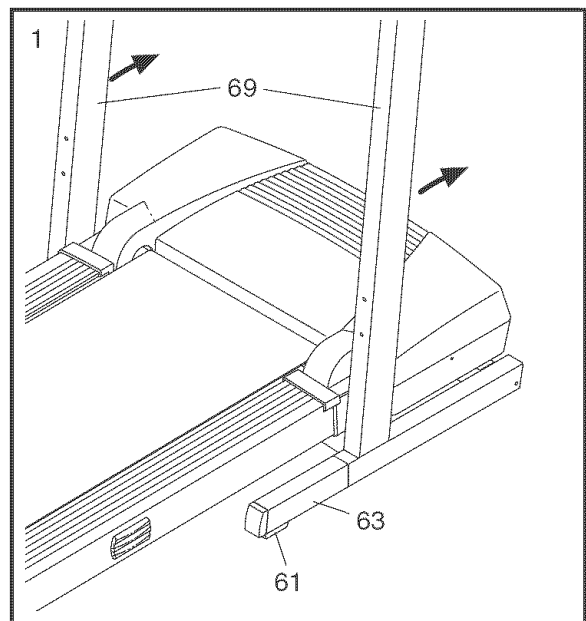

- With the help of another person, carefully lower the Uprights (69) as shown. Note: It may be helpful to place one foot on one of the Extension Legs (63) as you tip the Uprights. **Make sure that the Extension Legs remain in the Uprights.**

Attach each Extension Leg (63) with two 1" Tek Screws (39) and a Round Base Pad (57) as shown. **Attach the lower Tek Screw, without the Round Base Pad, first.**

Attach two more Round Base Pads (57) to the base of the Uprights (69) with two 1" Tek Screws (39). Note: One replacement Round Base Pad may be included. If a Round Base Pad becomes worn and needs to be replaced, use the replacement Round Base Pad.

Attach the two Wheels (66) with two 2" Bolts (64) and two Wheel Nuts (32) as shown. **Do not overtighten the Bolts;** the Wheels should be able to spin freely.

With the help of another person, carefully raise the Uprights (69) to the vertical position.

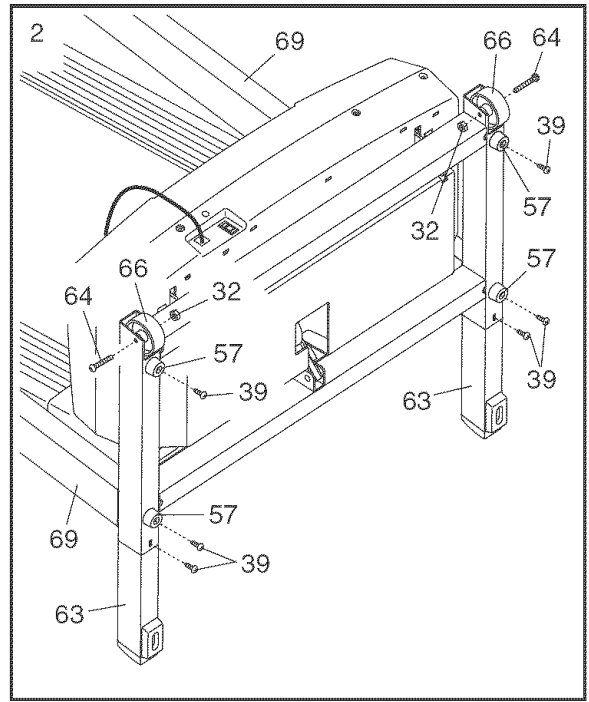

- With the help of a second person, tip the treadmill so the Base (not shown) is flat on the floor.

Insert the tab on one of the Handrail Brackets (40) into the slot in the right Upright (69). Attach the Handrail Bracket with a 3/4" Screw (2). Attach the other Handrail Bracket to the left Upright (not shown) as described above.

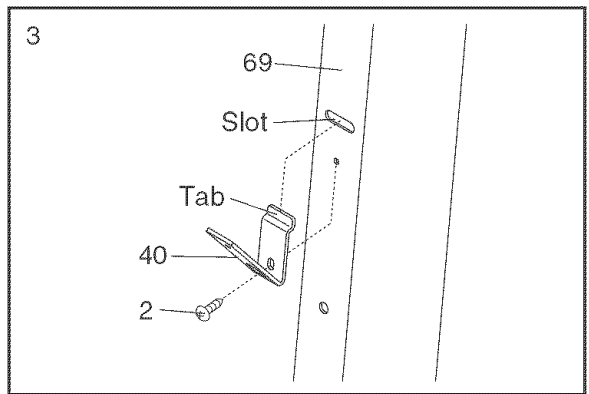

- Identify the Right Handrail (72), which has a large hole in the left side. Feed the Upright Wire (42) into the hole in the bottom of the Right Handrail and out of the large hole in the side. Note: It may be helpful to use needlenose pliers to pull the Wire Harness out of the hole.

Press a Handrail Cap (16) onto the lower end of the Right Handrail (5) as shown.

Set the Right Handrail (72) on the right Upright (69), with the lower end inserted into the Handrail Bracket (40).

Attach the Right Handrail (72) with an Upright Bolt (37) in the upper end and a 3/4" Screw (2) in the lower end.

Attach the Left Handrail (71) as described above. Note: There is not a wire harness on the left side.

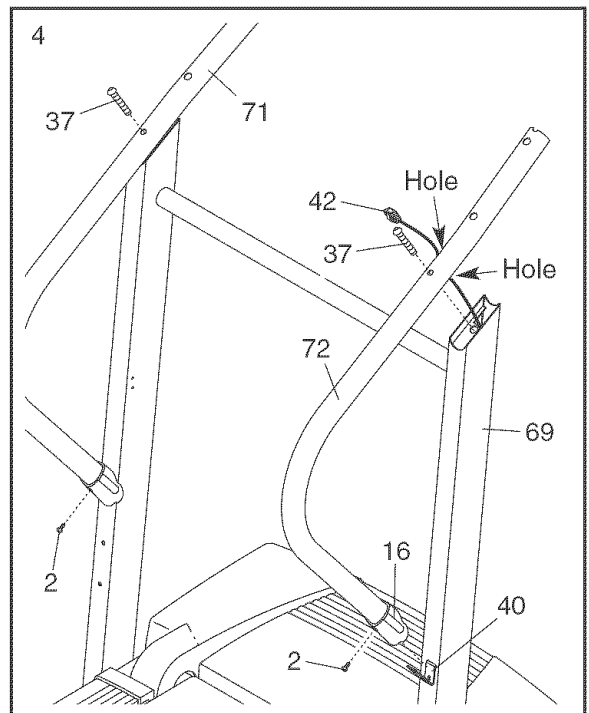

- Attach the Left Upper Body Arm (24) to the left Upright (69) with two 3 1/2" Bolts (45), two Washers (38), and two Star Washers (106) as shown. Make sure the Arm is on the indicated side of the crossbar.

Attach the Right Upper Body Arm (not shown) to the other Upright (not shown) in the same way.

Lower the Left Upper Body Arm (24) and the Right Upper Body Arm (not shown) toward the Foot Rails (98).

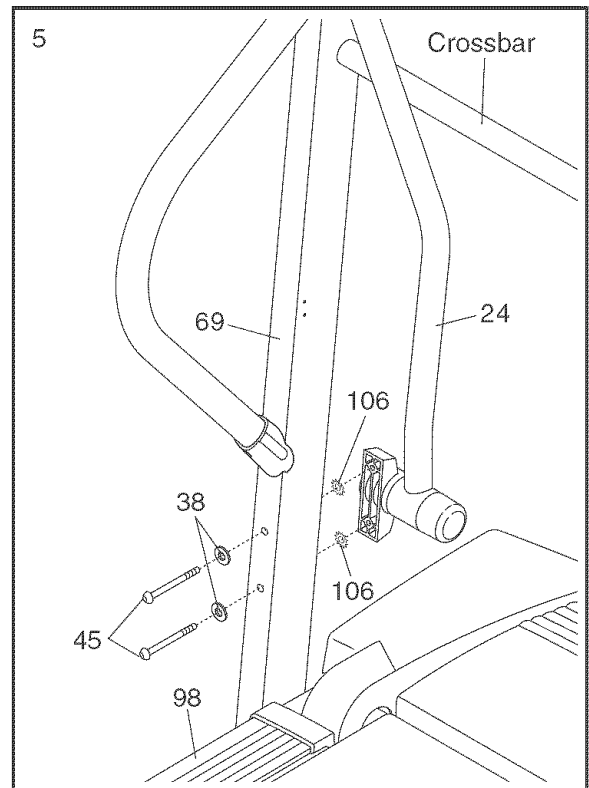

- Hold the Console Base (47) near the Left Handrail (71). Attach the end of the ground wire on the Console Base to the indicated small hole in the Left Handrail with the Silver Ground Screw (75).

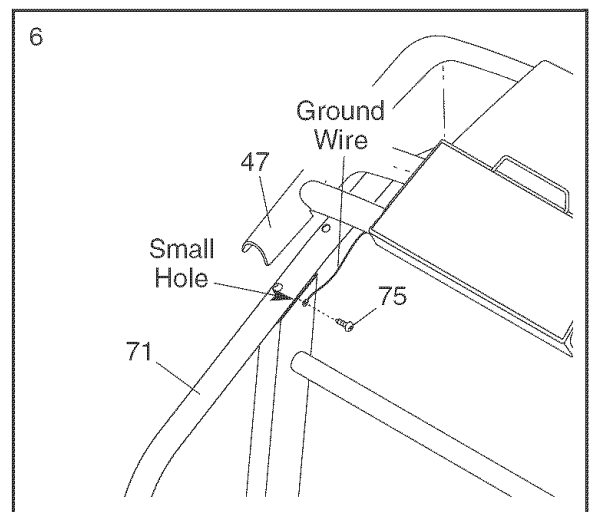

- Touch the Right Handrail (72) to discharge any static.** Press the end of the Upright Wire (42) into the socket in the bottom of the Console Base (47). **The connector should slide easily into the socket and snap into place.** If the connector does not slide easily and snap into place, turn the connector and then insert it.

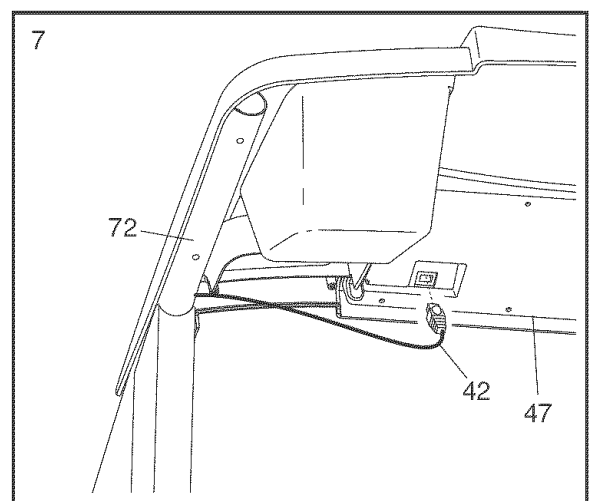

8. Set the Console Base (47) on the Right Handrail (72) and the Left Handrail (71). Attach the Console Base with four 3/4" Screws (2). **Start all four Screws before tightening them; do not overtighten the Screws.**

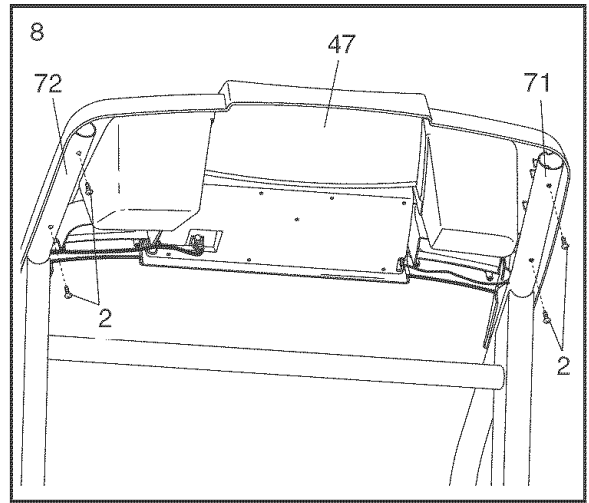

9. Press the Upright Wire (42) into the slot in the underside of the Console Base (47) in the indicated area. Cover the Upright Wire with the Right Grip Plate (36). **Be careful not to pinch the Upright Wire.** Tighten three 1/2" Screws (48) into the Right Grip Plate and the Console Base.

Attach the Left Grip Plate (32) over the ground wire and the other wires with three 1/2" Screws (48). **Be careful not to pinch any of the Wires.**

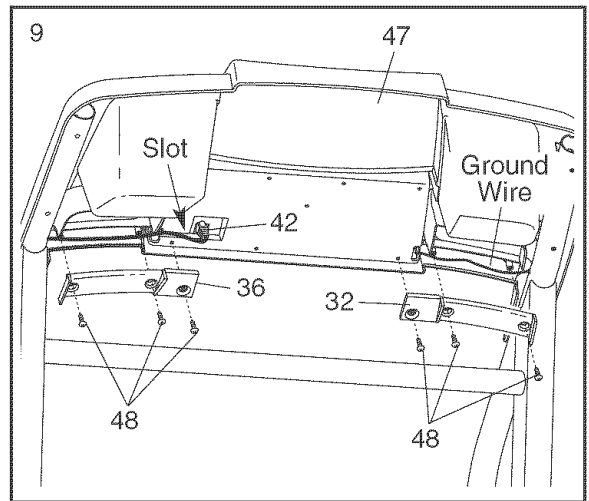

10. Attach the Storage Latch (29) and the Latch Spacer (44) to the left Upright (69) with two 3/4" Screws (2) as shown. **Do not overtighten the Screws.**

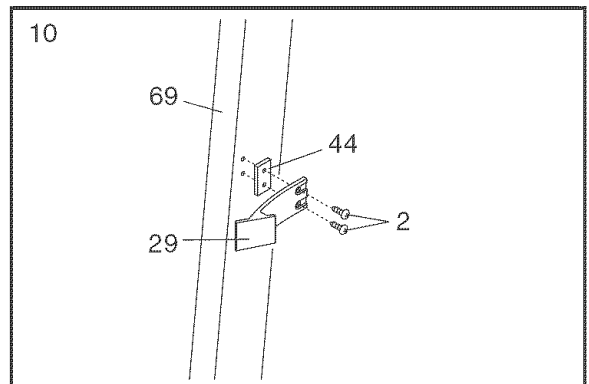

11. **Make sure that all parts are properly tightened before you use the treadmill.** Note: Extra hardware may be included. Keep the included allen wrenches in a secure place. The large allen wrench is used to adjust the walking belt (see page 17). To protect the floor or carpet, place a mat under the treadmill.

OPERATION AND ADJUSTMENT

THE PERFORMANT LUBE™ WALKING BELT

Your treadmill features a walking belt coated with PERFORMANT LUBE™, a high-performance lubricant. **IMPORTANT: Never apply silicone spray or other substances to the walking belt or the walking platform. Such substances will deteriorate the walking belt and cause excessive wear.**

HOW TO PLUG IN THE POWER CORD

⚠ DANGER: Improper connection of the equipment-grounding conductor can result in an increased risk of electric shock. Check with a qualified electrician or serviceman if you are in doubt as to whether the product is properly grounded. Do not modify the plug provided with the product—if it will not fit the outlet, have a proper outlet installed by a qualified electrician.

Your treadmill, like any other type of sophisticated electronic equipment, can be seriously damaged by sudden voltage changes in your home's power. Voltage surges, spikes, and noise interference can result from weather conditions or from other appliances being turned on or off. **To decrease the possibility of your treadmill being damaged, always use a surge suppressor with your treadmill (see drawing 1 at the right).** To purchase a surge suppressor, see your local Sears store or call 1-800-366-7278 and order part number 146148, or see your local electronics store.

Use only a single-outlet surge suppressor that is UL 1449 listed as a transient voltage surge suppressor (TVSS). The surge suppressor must have a UL suppressed voltage rating of 400 volts or less and a minimum surge dissipation of 450 joules. The surge suppressor must be electrically rated for 120 volts AC and 15 amps. There must be a monitoring light on the surge suppressor to indicate whether it is functioning properly. Failure to use a properly functioning surge suppressor could result in damage to the control system of the treadmill. If the control system is damaged, the walking belt may change speed or stop unexpectedly, which may result in a fall and serious injury.

This product must be grounded. If it should malfunction or break down, grounding provides a path of least resistance for electric current to reduce the risk of electric shock. This product is equipped with a cord having

an equipment-grounding conductor and a grounding plug. **Plug the power cord into a surge suppressor, and plug the surge suppressor into an appropriate outlet that is properly installed and grounded in accordance with all local codes and ordinances. Important: The treadmill is not compatible with GFCI-equipped outlets.**

This product is for use on a nominal 120-volt circuit, and has a grounding plug that looks like the plug illustrated in drawing 1 below. A temporary adapter that looks like the adapter illustrated in drawing 2 may be used to connect the surge suppressor to a 2-pole receptacle as shown in drawing 2 if a properly grounded outlet is not available.

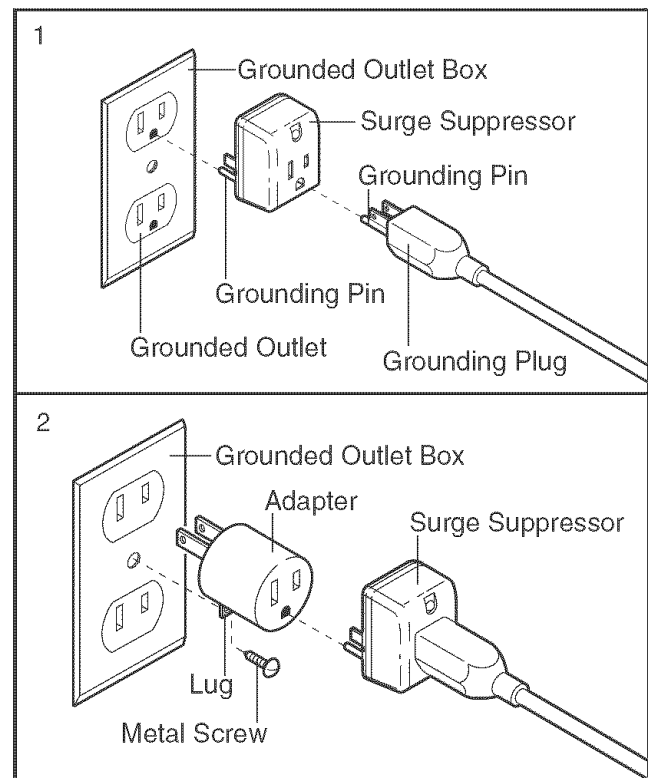

The temporary adapter should be used only until a properly grounded outlet (drawing 1) can be installed by a qualified electrician.

The green-colored rigid ear, lug, or the like extending from the adapter must be connected to a permanent ground such as a properly grounded outlet box cover. Whenever the adapter is used it must be held in place by a metal screw. **Some 2-pole receptacle outlet box covers are not grounded. Contact a qualified electrician to determine if the outlet box cover is grounded before using an adapter.**

CONSOLE DIAGRAM

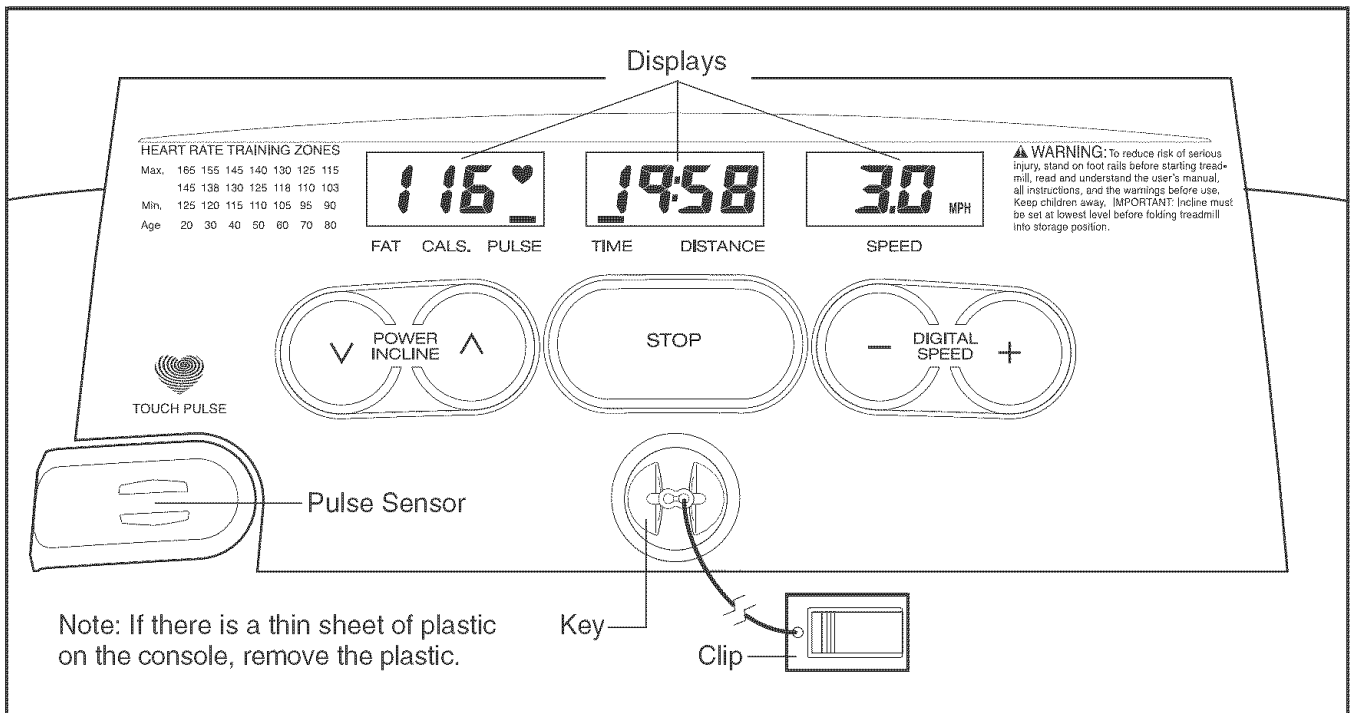

CAUTION: Before operating the console, read the following precautions.

- Do not stand on the walking belt when turning on the power.
- Always wear the clip (see the drawing above) while operating the treadmill.
- Adjust the speed in small increments to avoid sudden jumps in speed.
- To reduce the possibility of electric shock, keep the console dry. Avoid spilling liquids on the console and place only a sealed water bottle in the accessory trays.

STEP-BY-STEP CONSOLE OPERATION

Before operating the console, make sure that the power cord is properly plugged in (see page 10).

The reset/off circuit breaker, located on the treadmill frame near the power cord, should be in the reset position.

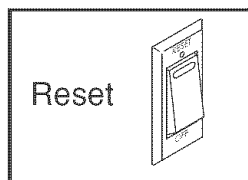

Next, stand on the foot rails of the treadmill. Find the clip attached to the key (see the drawing above), and slide the clip onto the waistband of your clothes. Insert the key into the console. A tone will sound and the three displays will light. **Test the clip by carefully taking a few steps backward until the key is pulled from the console. If the key is not pulled from the console, adjust the position of the clip.**

Follow the steps below to operate the console.

1 Insert the key into the console.

When the key is inserted, a tone will sound and the three displays will light.

2 Press the Speed + button to start the walking belt.

A moment after the button is pressed, the walking belt will begin to move. Hold the handrails and begin walking.

As you exercise, change the speed of the walking belt as desired by pressing the Speed buttons. Each time a button is pressed, the speed setting will change by 0.1 mph; if a button is held down, the speed setting will change in increments of 0.5 mph. **Note: The console can display speed and distance in either miles or kilometers (see SPEED DISPLAY on page 12). For simplicity, all instructions in this section refer to miles.**

To stop the walking belt, press the Stop button. The Time/Distance display will begin to flash.

Note: During the first few minutes that the treadmill is used, inspect the alignment of the walking belt, and align it if necessary (see page 16).

3 Change the incline of the treadmill as desired.

To change the incline of the treadmill, press either of the Incline buttons until the desired incline level is reached.

4 Follow your progress with the three displays.

Fat Calories/Calories/Pulse display—This display shows the approximate numbers of *fat calories* and *calories* you have burned (see FAT BURNING on page 18). The display will change from one number to the other every few seconds, as shown by the mode indicators. This display will also show your heart rate when you use the pulse sensor (see step 5).

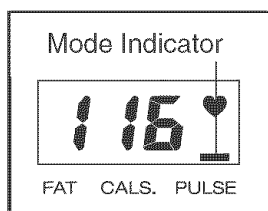

Time/Distance display—This display shows the elapsed time and the distance that you have walked or run. The display will change from one number to the other every few seconds, as shown by the mode indicators. Note: When the Stop button is pressed, this display will flash.

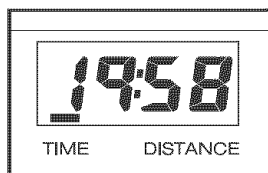

Speed display—This display shows the speed of the walking belt.

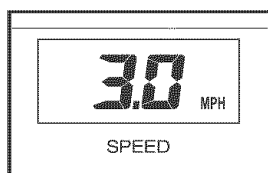

Note: The console can display speed and distance in either miles or kilometers. To change the unit of measurement, hold down the Stop button

while inserting the key into the console. An "E" for English miles or an "M" for metric kilometers will appear in the Speed display. Press the Speed + button to change the unit of measurement. When the desired unit of measurement is selected, remove the key and then reinsert it.

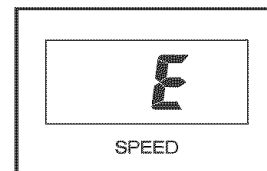

To reset the displays, press the Stop button, remove the key, and then reinsert the key.

5 Measure your heart rate if desired.

To measure your heart rate, stand on the foot rails and place your thumb on the pulse sensor. **Do not press too hard, or the circulation in your thumb will be restricted and your pulse will not be detected.** After a few seconds, the heart-shaped indicator in the Fat Calories/Calories/Pulse display will begin to flash, and then your heart rate will be shown. Hold your thumb on the pulse sensor for about 15 seconds for the most accurate reading.

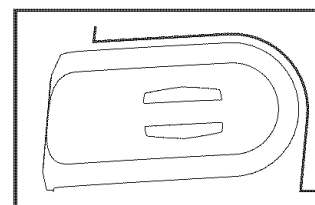

If the displayed heart rate appears to be too high or too low, or if your heart rate is not displayed, lift your thumb off the pulse sensor for a few seconds. Then, place your thumb on the pulse sensor as described above. Remember to stand still while measuring your heart rate.

6 When you are finished exercising, remove the key.

Step onto the foot rails, press the Stop button, and remove the key from the console. Keep the key in a secure place. Move the reset/off circuit breaker to the off position and unplug the power cord.

HOW TO USE THE UPPER BODY ARMS

As you walk on the treadmill, you can either hold the handrails or use the upper body arms. To exercise your arms, shoulders, and back for a total body workout, move the upper body arms forward and back as you walk on the treadmill.

To vary the intensity of your upper body exercise, the resistance of the upper body arms can be adjusted. To increase the resistance, turn the resistance knobs clockwise; to decrease the resistance, turn the knobs counterclockwise.

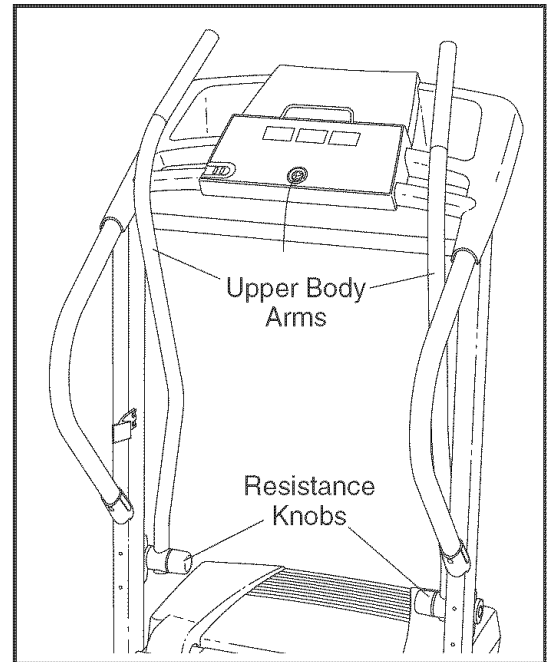

HOW TO FOLD AND MOVE THE TREADMILL

HOW TO FOLD THE TREADMILL FOR STORAGE

Before folding the treadmill, adjust the incline to the lowest position. If this is not done, the treadmill may be permanently damaged. Next, unplug the power cord. **CAUTION:** You must be able to safely lift 45 pounds (20 kg) to raise, lower, or move the treadmill.

1. Hold the treadmill with your hands in the locations shown at the right. **To decrease the possibility of injury, bend your legs and keep your back straight. As you raise the treadmill, make sure to lift with your legs rather than your back.** Raise the treadmill about halfway to the vertical position.

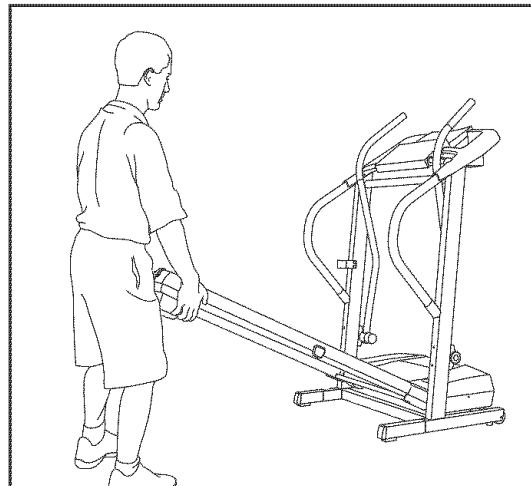

2. Move your right hand to the position shown and hold the treadmill firmly. Using your left thumb, press the storage latch to the left. Raise the treadmill until the storage latch closes over the catch. **Make sure that the storage latch is fully engaged over the catch.**

To protect the floor or carpet from damage, place a mat under the treadmill. Keep the treadmill out of direct sunlight. Do not leave the treadmill in the storage position in temperatures above 85° Fahrenheit.

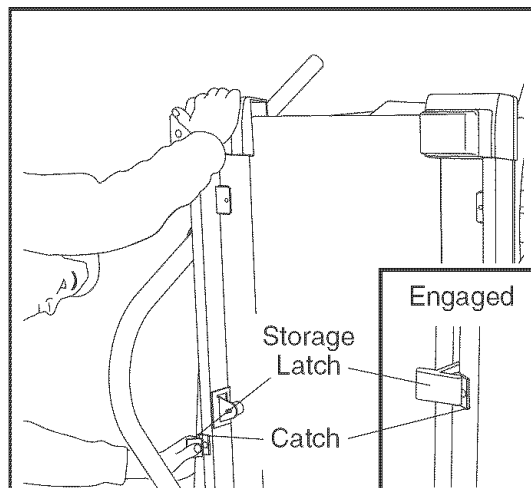

HOW TO MOVE THE TREADMILL

Before moving the treadmill, convert the treadmill to the storage position as described above. **Make sure that the frame is securely held by the storage latch.**

1. Hold the upper ends of the handrails. Place one foot on the base as shown.
2. Tilt the treadmill back until it rolls freely on the front wheels. Carefully move the treadmill to the desired location. **To reduce the risk of injury, use extreme caution while moving the treadmill. Do not move the treadmill over an uneven surface.**
3. Place one foot on the base, and carefully lower the treadmill until it is resting in the storage position.

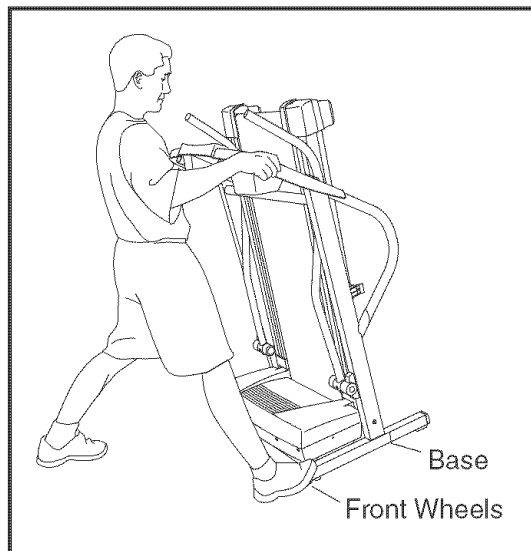

HOW TO LOWER THE TREADMILL FOR USE

1. Hold the upper end of the treadmill with your right hand. Press the storage latch to the left. Pivot the treadmill down until the frame and foot rail are past the storage latch.

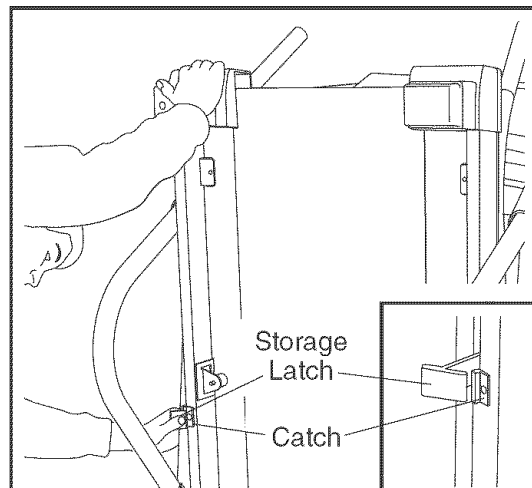

2. Hold the treadmill firmly with both hands, and lower the treadmill to the floor. **Do not drop the treadmill frame to the floor. To decrease the possibility of injury, bend your legs and keep your back straight.**

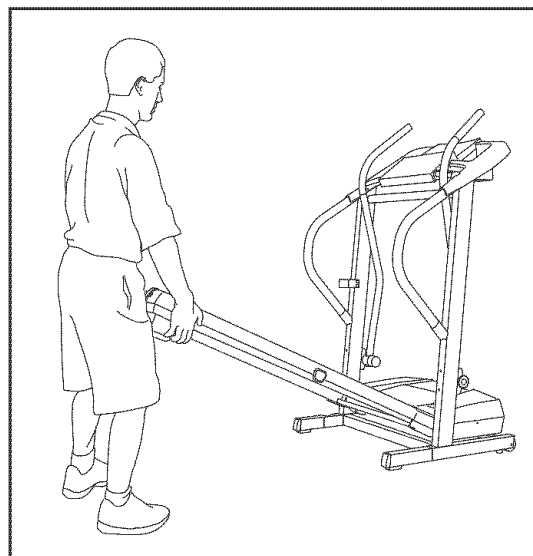

TROUBLESHOOTING

Most treadmill problems can be solved by following the simple steps below. Find the symptom that applies, and follow the steps listed. If further assistance is needed, call toll-free 1-800-4-MY-HOME® (1-800-469-4663).

PROBLEM: The power does not turn on

SOLUTION: a. Make sure that the power cord is plugged into a surge suppressor, and that the surge suppressor is plugged into a properly grounded outlet (see page 10). Use only a single-outlet surge suppressor that meets all of the specifications described on page 10. Important: The treadmill is not compatible with GFCI-equipped outlets.

b. After the power cord has been plugged in, make sure that the key is fully inserted into the console.

c. Check the reset/off circuit breaker located on the treadmill frame near the power cord. If the switch protrudes as shown, the circuit breaker has tripped. To reset the circuit breaker, wait for five minutes and then press the switch back in.

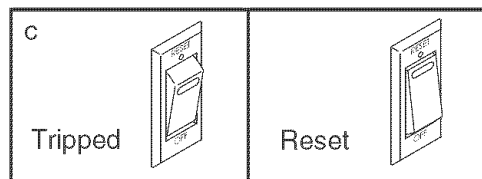

PROBLEM: The power turns off during use

SOLUTION: a. Check the circuit breaker located on the treadmill frame near the power cord (see the drawing above). If the circuit breaker has tripped, wait for five minutes and then press the switch back in.

b. Make sure that the power cord is plugged in. If the power cord is plugged in, unplug it, wait for five minutes, and then plug it back in.

c. Remove the key from the console. Reinsert the key fully into the console.

d. If the treadmill still will not run, please call toll-free 1-800-4-MY-HOME® (1-800-469-4663).

PROBLEM: The displays of the console do not function properly

SOLUTION: a. Remove the key from the console and **UNPLUG THE POWER CORD**. Remove the Screws (58) from the Hood (1), and carefully pivot the Hood off.

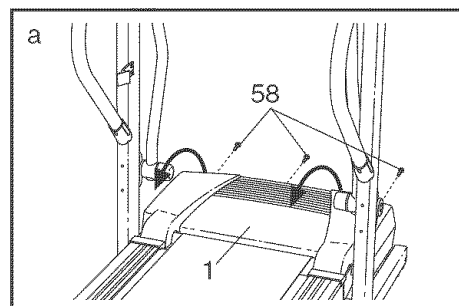

Locate the Reed Switch (10) and the Magnet (18) on the left side of the Pulley (17). Turn the Pulley until the Magnet is aligned with the Reed Switch. **Make sure that the gap between the Magnet and the Reed Switch is about 1/8"**. If necessary, loosen the Screw (58), move the Reed Switch slightly, and then retighten the Screw. Reattach the Hood, and run the treadmill for a few minutes to check for a correct speed reading.

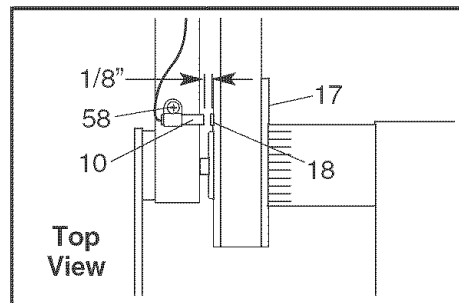

PROBLEM: The walking belt slows when walked on

SOLUTION: a. Use only a single-outlet surge suppressor that meets all of the specifications described on page 10.

b. If the walking belt is overtightened, treadmill performance may decrease and the walking belt may become damaged. Remove the key and **UNPLUG THE POWER CORD**. Using the allen wrench, turn both rear roller adjustment bolts counterclockwise, 1/4 of a turn. When the walking belt is properly tightened, you should be able to lift each side of the walking belt 2 to 3 inches off the walking platform. Be careful to keep the walking belt centered. Plug in the power cord, insert the key, and run the treadmill for a few minutes. Repeat until the walking belt is properly tightened.

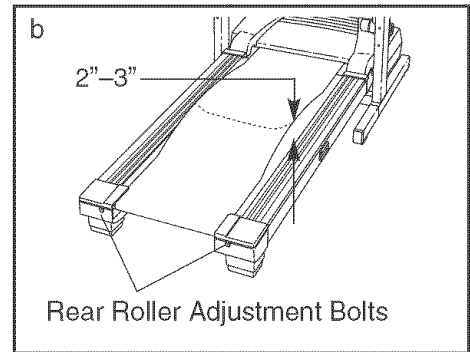

c. If the walking belt still slows when walked on, please call toll-free 1-800-4-MY-HOME® (1-800-469-4663).

PROBLEM: The walking belt is off-center or slips when walked on

SOLUTION: a. If the walking belt is off-center, first remove the key and **UNPLUG THE POWER CORD**. **If the walking belt has shifted to the left**, use the allen wrench to turn the left rear roller bolt clockwise 1/2 of a turn; **if the walking belt has shifted to the right**, turn the left bolt counterclockwise 1/2 of a turn. Be careful not to overtighten the walking belt. Plug in the power cord, insert the key, and run the treadmill for a few minutes. Repeat until the walking belt is centered.

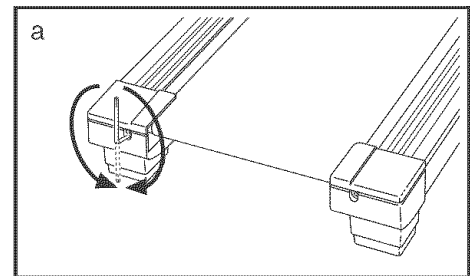

b. If the walking belt slips when walked on, first remove the key and **UNPLUG THE POWER CORD**. Using the allen wrench, turn both rear roller bolts clockwise, 1/4 of a turn. When the walking belt is correctly tightened, you should be able to lift each side of the walking belt 2 to 3 inches off the walking platform. Be careful to keep the walking belt centered. Plug in the power cord, insert the key, and carefully walk on the treadmill for a few minutes. Repeat until the walking belt is properly tightened.

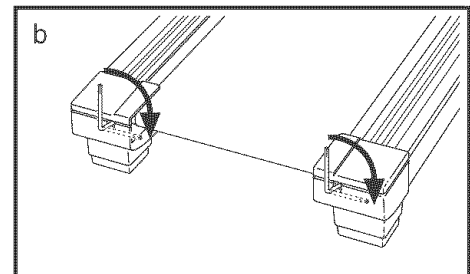

CONDITIONING GUIDELINES

⚠️ WARNING: Before beginning this or any exercise program, consult your physician. This is especially important for individuals over the age of 35 or individuals with pre-existing health problems.

The pulse sensor is not a medical device. Various factors, including your movement, may affect the accuracy of heart rate readings. The sensor is intended only as an exercise aid in determining heart rate trends in general.

The following guidelines will help you to plan your exercise program. For more detailed exercise information, obtain a reputable book or consult your physician.

EXERCISE INTENSITY

Whether your goal is to burn fat or to strengthen your cardiovascular system, the key to achieving the desired results is to exercise with the proper intensity. The proper intensity level can be found by using your heart rate as a guide. The chart below shows recommended heart rates for fat burning and aerobic exercise.

AEROBIC	165	155	145	140	130	125	115
MAX FAT BURN	145	138	130	125	118	110	103
FAT BURN	125	120	115	110	105	95	90
Age	20	30	40	50	60	70	80

To find the proper heart rate for you, first find your age near the bottom of the chart (ages are rounded off to the nearest ten years). Next, find the three numbers above your age. The three numbers define your "training zone." The lower two numbers are recommended heart rates for fat burning; the higher number is the recommended heart rate for aerobic exercise.

To measure your heart rate during exercise, use the pulse sensor.

Fat Burning

To burn fat effectively, you must exercise at a relatively low intensity level for a sustained period of time. During the first few minutes of exercise, your body uses easily accessible *carbohydrate calories* for en-

ergy. Only after the first few minutes does your body begin to use stored *fat calories* for energy. If your goal is to burn fat, adjust the speed and incline of the treadmill until your heart rate is near the lowest number in your training zone.

For maximum fat burning, adjust the speed and incline of the treadmill until your heart rate is near the middle number in your training zone.

Aerobic Exercise

If your goal is to strengthen your cardiovascular system, your exercise must be "aerobic." Aerobic exercise is activity that requires large amounts of oxygen for prolonged periods of time. This increases the demand on the heart to pump blood to the muscles, and on the lungs to oxygenate the blood. For aerobic exercise, adjust the speed and incline of the treadmill until your heart rate is near the highest number in your training zone.

WORKOUT GUIDELINES

Each workout should include the following three parts:

A Warm-up—Start each workout with 5 to 10 minutes of stretching and light exercise. A proper warm-up increases your body temperature, heart rate and circulation in preparation for exercise.

Training Zone Exercise—After warming up, increase the intensity of your exercise until your pulse is in your training zone for 20 to 60 minutes. (During the first few weeks of your exercise program, do not keep your pulse in your training zone for longer than 20 minutes.) Breathe regularly and deeply as you exercise—never hold your breath.

A Cool-down—Finish each workout with 5 to 10 minutes of stretching to cool down. This will increase the flexibility of your muscles and will help prevent post-exercise problems.

EXERCISE FREQUENCY

To maintain or improve your condition, complete three workouts each week, with at least one day of rest between workouts. After a few months, you may complete up to five workouts each week if desired. The key to success is to make exercise a regular and enjoyable part of your everyday life.

SUGGESTED STRETCHES

The correct form for several basic stretches is shown at the right. Move slowly as you stretch—never bounce.

1. Toe Touch Stretch

Stand with your knees bent slightly and slowly bend forward from your hips. Allow your back and shoulders to relax as you reach down toward your toes as far as possible. Hold for 15 counts, then relax. Repeat 3 times. Stretches: Hamstrings, back of knees and back.

2. Hamstring Stretch

Sit with one leg extended. Bring the sole of the opposite foot toward you and rest it against the inner thigh of your extended leg. Reach toward your toes as far as possible. Hold for 15 counts, then relax. Repeat 3 times for each leg. Stretches: Hamstrings, lower back and groin.

3. Calf/Achilles Stretch

With one leg in front of the other, reach forward and place your hands against a wall. Keep your back leg straight and your back foot flat on the floor. Bend your front leg, lean forward and move your hips toward the wall. Hold for 15 counts, then relax. Repeat 3 times for each leg. To cause further stretching of the achilles tendons, bend your back leg as well. Stretches: Calves, achilles tendons and ankles.

4. Quadriceps Stretch

With one hand against a wall for balance, reach back and grasp one foot with your other hand. Bring your heel as close to your buttocks as possible. Hold for 15 counts, then relax. Repeat 3 times for each leg. Stretches: Quadriceps and hip muscles.

5. Inner Thigh Stretch

Sit with the soles of your feet together and your knees outward. Pull your feet toward your groin area as far as possible. Hold for 15 counts, then relax. Repeat 3 times. Stretches: Quadriceps and hip muscles.

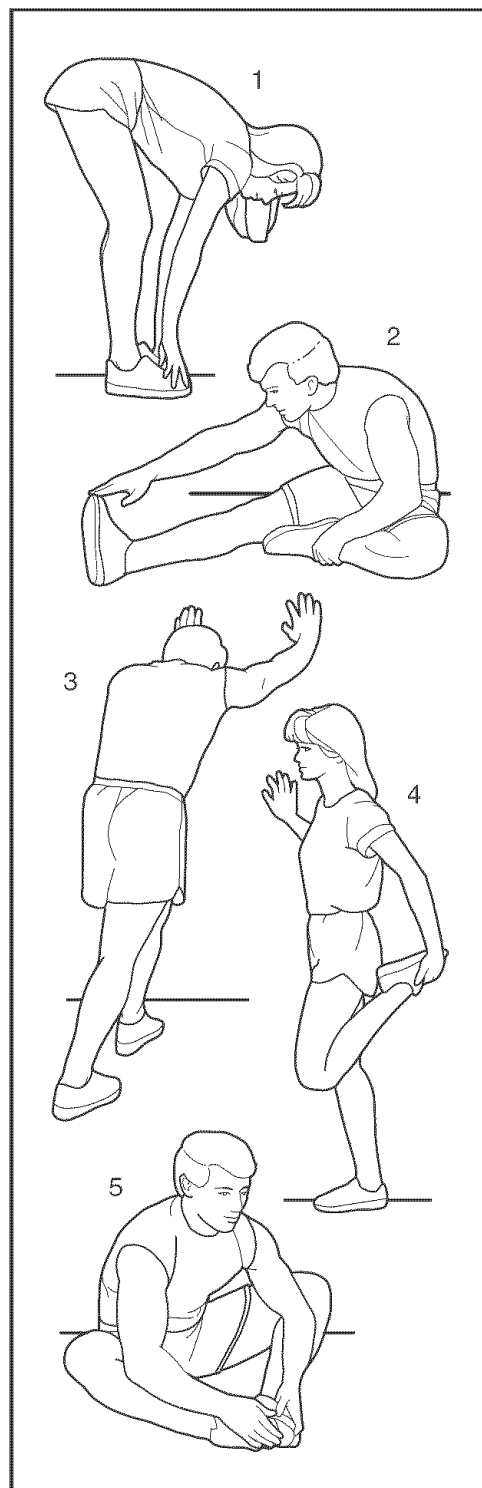

PART LIST—Model No. 831.295030

R0804B

Key No.	Qty.	Description	Key No.	Qty.	Description	Key No.	Qty.	Description
1	1	Hood	41	1	5/32" Allen Wrench	86	1	Frame
2	15	3/4" Screw	42	1	Upright Wire	87	4	Releasable Tie
3	1	Motor Belt	43	1	Console	88	1	Warning Decal
4	1	Motor Tension Bolt	44	1	Latch Spacer	89	2	Cable Tie Clamp
5	9	3/8" Washer	45	4	3 1/2" Bolt	90	1	Outlet Plate
6	1	Motor Star Washer	46	1	Book Holder	91	1	Sensor Clip
7	1	Flywheel	47	1	Console Base	92	2	Rear Roller
8	1	Motor	48	6	1/2" Screw			Adjustable Bolt
9*	1	Motor Assembly	49	8	Foot Rail Screw	93	1	Right Rear Endcap
10	1	Reed Switch	50	1	Key/Clip	94	1	Allen Wrench
11	1	Latch Warning Decal	51	1	Incline Motor	95	1	Left Rear Endcap
12	2	Frame Spacer	52	1	Incline Bracket	96	1	Walking Belt
13	5	Frame Pivot	53	1	Incline Motor	97	1	Walking Platform
		Nut/Motor Nut			Bolt (lower)	98	2	Foot Rail
14	2	Frame Pivot Bolt	54	2	Incline Pivot Bolt	99	2	U-Nut
15	6	Walking Platform	55	2	Incline Pivot Nut	100	1	Rear Roller
		Screw	56	1	Motor Controller Wire	101	2	Upper Body
16	2	Handrail Cap	57	4	Round Base Pad			Arm Screw
17	1	Front Roller/Pulley	58	12	3/4" Tek Screw	102	1	Incline Motor
18	1	Magnet	59	1	Controller			Bolt (upper)
19	1	Motor Pivot Bolt	60	1	Lift Frame	103	1	Motor Mount Bracket
20	2	Motor Bracket Bolt	61	2	Base Pad	104	2	Resistance Bolt
21	1	Right Foot Rail	62	2	Warning Decal	105	2	Resistance Bracket
		Endcap	63	2	Extension Leg	106	4	Star Washer
22	2	Belly Pan Clip	64	2	2" Bolt	107	2	Resistance Sleeve
23	1	Front Roller	65	4	Base Endcap	108	2	Resistance Cone
		Adjustment Bolt	66	2	Wheel	109	2	Resistance Knob
24	1	Left Upper Body Arm	67	6	Endcap Screw	110	2	Front Isolator
		w/Foam Grip	68	4	8" Cable Tie	111	2	Spring Washer
25	1	Right Upper Body	69	1	Base	112	4	Thrust Washer
		Arm w/Foam Grip	70	1	Grommet	113	2	Thrust Bearing
26	6	Ground Screw	71	1	Left Handrail	114	2	Foam Grip
27	2	Resistance Plate	72	1	Right Handrail	#	1	6" Black Wire, 2 Ring
28	1	Motor Tension Nut	73	1	Choke	#	1	4" Black Wire, 2F
29	1	Storage Latch	74	1	Left Foot Rail Endcap	#	1	4" Black Wire, M/F
30	1	Latch Catch	75	1	Silver Ground Screw	#	1	6" Green Wire, F/R
31	2	Rear Endcap Pad	76	1	Isolator Insert	#	1	4" White Wire, M/F
32	2	Wheel Nut	77	4	Belly Pan Screw	#	1	4" Blue Wire, 2F
33	2	Static Decal	78	1	Reset/Off Switch	#	1	4" Red Wire, M/F
34	1	Left Grip Plate	79	1	Power Cord	#	1	User's Manual
35	1	Electronic Bracket	80	1	Power Cord Grommet			
36	1	Right Grip Plate	81	1	Belly Pan			
37	2	2 1/2" Bolt	82	2	Belt Guide			
38	6	Washer	83	4	Belt Guide Screw			
39	6	1" Tek Screw	84	2	Isolator Screw			
40	2	Handrail Bracket	85	2	Isolator Cushion			

*Includes all parts shown in the box

#These parts are not illustrated

**If a part is missing, call toll-free
1-888-533-1333.**

EXPLODED DRAWING—Model No. 831.295030

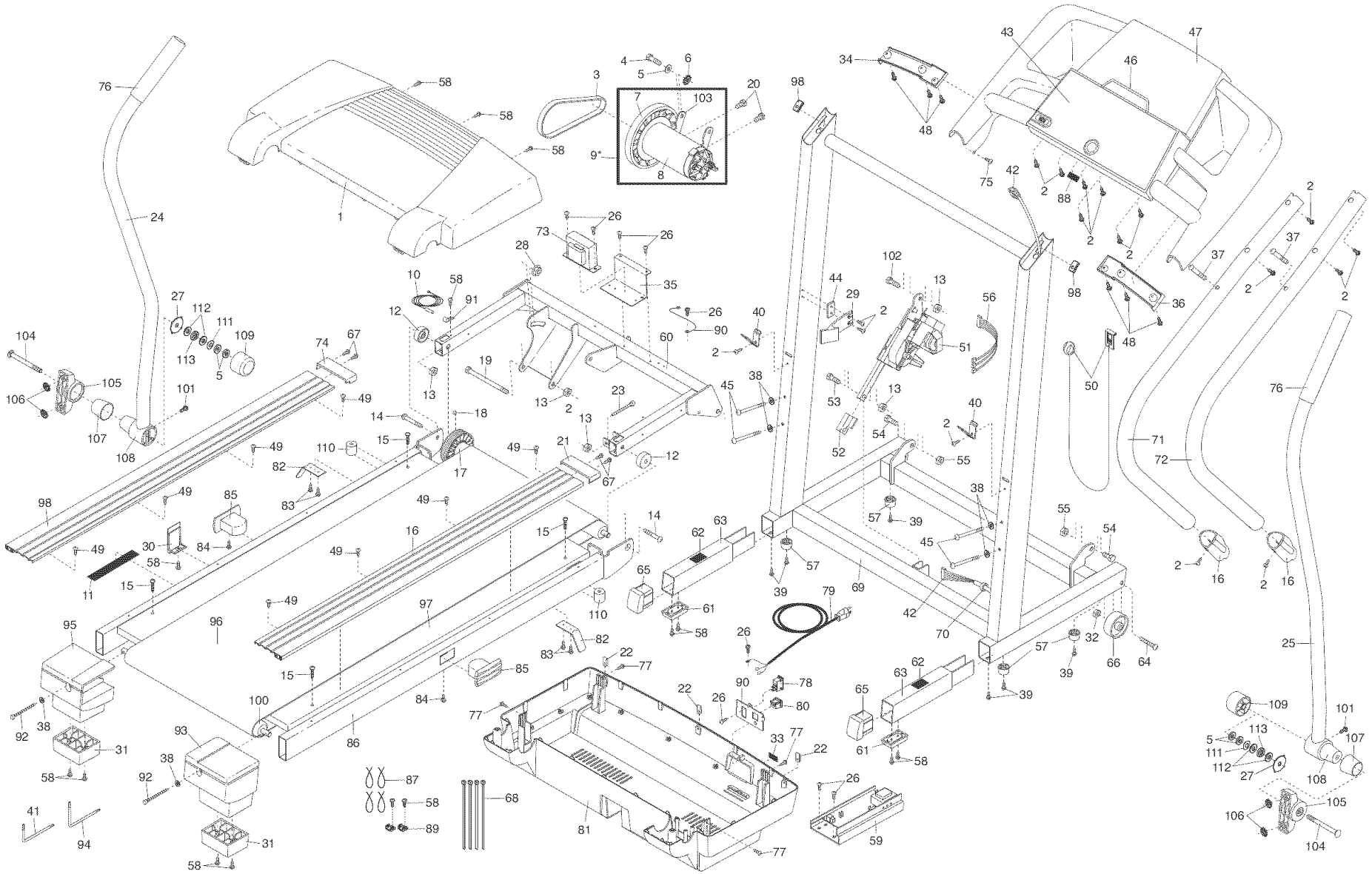

R0804B

Get it fixed, at your home or ours!

Your Home

For repair – **in your home** – of **all** major brand appliances, lawn and garden equipment, or heating and cooling systems, **no matter who made it, no matter who sold it!**

For the replacement parts, accessories, and user's manuals that you need to do-it-yourself.

For Sears professional installation of home appliances and items like garage door openers and water heaters.

1-800-4-MY-HOME®

(1-800-469-4663)

www.sears.com

Anytime, day or night

(U.S.A. and Canada)

www.sears.ca

Our Home

For repair of carry-in products like vacuums, lawn equipment, and electronics, call or go on-line for the location of your nearest **Sears Parts and Repair Center.**

1-800-488-1222 Anytime, day or night (U.S.A. only)

www.sears.com

To purchase a protection agreement (U.S.A.) or maintenance agreement (Canada) on a product serviced by Sears:

1-800-827-6655 (U.S.A.)

1-800-361-6665 (Canada)

Para pedir servicio de reparación a domicilio, y para ordenar piezas:

1-888-SU-HOGARSM (1-888-784-6427)

SEARS

® Registered Trademark / ™ Trademark / SM Service Mark of Sears, Roebuck and Co.
® Marca Registrada / ™ Marca de Fábrica / SM Marca de Servicio de Sears, Roebuck and Co.

FULL 90 DAY WARRANTY

For 90 days from the date of purchase, if failure occurs due to defect in material or workmanship in this Sears Treadmill Exerciser, contact the nearest Sears Service Center throughout the United States and Sears will repair or replace the Treadmill Exerciser, free of charge. The motor is warranted for three (3) years from the date of purchase.

This warranty does not apply when the Treadmill Exerciser is used commercially or for rental purposes.

This warranty gives you specific legal rights, and you may also have other rights which vary from state to state.

Sears, Roebuck and Co., Dept. 817WA, Hoffman Estates, IL 60179